



FCC RF Test Report

APPLICANT : ASUSTeK COMPUTER INC.
EQUIPMENT : ASUS Phone
BRAND NAME : ASUS
MODEL NAME : ASUS_Z016D
FCC ID : MSQZ016D
STANDARD : FCC 47 CFR Part 2, 22(H), 24(E), 27(L)
CLASSIFICATION : PCS Licensed Transmitter Held to Ear (PCE)

The product was received on Apr. 19, 2016 and testing was completed on Aug. 05, 2016. We, SPORTON INTERNATIONAL INC., would like to declare that the tested sample has been evaluated in accordance with the test procedures given in ANSI / TIA / EIA-603-D-2010 and has been in compliance with the applicable technical standards.

The test results in this report apply exclusively to the tested model / sample. Without written approval of SPORTON INTERNATIONAL INC., the test report shall not be reproduced except in full.

Reviewed by: Joseph Lin / Supervisor

Approved by: Jones Tsai / Manager



SPORTON INTERNATIONAL INC.

No. 52, Hwa Ya 1st Rd., Hwa Ya Technology Park, Kwei-Shan District, Tao Yuan City, Taiwan, R.O.C.

SPORTON INTERNATIONAL INC.

TEL : 886-3-327-3456

FAX : 886-3-328-4978

FCC ID : MSQZ016D

Page Number : 1 of 23

Report Issued Date : Aug. 19, 2016

Report Version : Rev. 02

Report Template No.: BU5-FG22/24/27 Version 1.1



TABLE OF CONTENTS

REVISION HISTORY..... 3

SUMMARY OF TEST RESULT 4

1 GENERAL DESCRIPTION 5

 1.1 Applicant..... 5

 1.2 Manufacturer 5

 1.3 Product Feature of Equipment Under Test 5

 1.4 Product Specification of Equipment Under Test 6

 1.5 Modification of EUT 6

 1.6 Maximum ERP/EIRP Power, Frequency Tolerance, and Emission Designator 7

 1.7 Testing Location 8

 1.8 Applicable Standards 8

2 TEST CONFIGURATION OF EQUIPMENT UNDER TEST 9

 2.1 Test Mode..... 9

 2.2 Connection Diagram of Test System 10

 2.3 Support Unit used in test configuration 10

 2.4 Measurement Results Explanation Example 10

3 CONDUCTED TEST RESULT 11

 3.1 Measuring Instruments..... 11

 3.2 Test Setup 11

 3.3 Test Result of Conducted Test..... 11

 3.4 Conducted Output Power 12

 3.5 Peak-to-Average Ratio 13

 3.6 99% Occupied Bandwidth and 26dB Bandwidth Measurement..... 14

 3.7 Conducted Band Edge 15

 3.8 Conducted Spurious Emission 16

 3.9 Frequency Stability..... 17

4 RADIATED TEST ITEMS 18

 4.1 Measuring Instruments..... 18

 4.2 Test Setup 18

 4.3 Test Result of Radiated Test..... 18

 4.4 Effective Radiated Power and Effective Isotropic Radiated Power Measurement 19

 4.5 Field Strength of Spurious Radiation Measurement 21

5 LIST OF MEASURING EQUIPMENT 22

6 UNCERTAINTY OF EVALUATION 23

APPENDIX A. TEST RESULTS OF CONDUCTED TEST

APPENDIX B. TEST RESULTS OF RADIATED TEST

APPENDIX C. TEST SETUP PHOTOGRAPHS



REVISION HISTORY

REPORT NO.	VERSION	DESCRIPTION	ISSUED DATE
FG641901A	Rev. 01	Initial issue of report	Aug. 16, 2016
FG641901A	Rev. 02	Revising the Maximum ERP/EIRP in section 1.6	Aug. 19, 2016



SUMMARY OF TEST RESULT

Report Section	FCC Rule	Description	Limit	Result	Remark
3.4	§2.1046	Conducted Output Power	Reporting Only	PASS	-
3.5	§24.232(d)	Peak-to-Average Ratio	< 13 dB	PASS	-
3.6	§2.1049 §22.917(b) §24.238(b) §27.53(g)	Occupied Bandwidth	Reporting Only	PASS	-
3.7	§2.1051 §22.917(a) §24.238(a) §27.53(h)	Band Edge Measurement	< 43+10log10(P[Watts])	PASS	-
3.8	§2.1051 §22.917(a) §24.238(a) §27.53(h)	Conducted Emission	< 43+10log10(P[Watts])	PASS	-
3.9	§2.1055 §22.355	Frequency Stability for Temperature & Voltage	< 2.5 ppm for Part 22	PASS	-
	§2.1055 §24.235 §27.54		Within Authorized Band		
4.4	§22.913(a)(2)	Effective Radiated Power	< 7 Watts	PASS	-
	§24.232(c)	Equivalent Isotropic Radiated Power	< 2 Watts	PASS	-
	§27.50(d)(4)	Equivalent Isotropic Radiated Power	< 1 Watts	PASS	-
4.5	§2.1053 §22.917(a) §24.238(a) §27.53(h)	Field Strength of Spurious Radiation	< 43+10log10(P[Watts])	PASS	Under limit 17.14 dB at 2509.000 MHz



1 General Description

1.1 Applicant

ASUSTeK COMPUTER INC.

4F, No. 150, LI-TE RD., PEITOU, TAIPEI, TAIWAN

1.2 Manufacturer

COTEK ELECTRONICS (SUZHOU) CO., LTD.

No. 288, Mayun Road, Suzhou New District, Jiangsu, PRC

1.3 Product Feature of Equipment Under Test

Product Feature	
Equipment	ASUS Phone
Brand Name	ASUS
Model Name	ASUS_Z016D
FCC ID	MSQZ016D
EUT supports Radios application	CDMA/EV-DO /GSM/EGPRS/WCDMA/HSPA/LTE/NFC WLAN 11a/b/g/n HT20/HT40 WLAN 11ac VHT20/VHT40/VHT80 Bluetooth v4.2 BR/EDR/LE
HW Version	REV2.0
SW Version	4.0.20.270
EUT Stage	Production Unit

Remark: The above EUT's information was declared by manufacturer. Please refer to the specifications or user's manual for more detailed description.



1.4 Product Specification of Equipment Under Test

Standards-related Product Specification	
Tx Frequency	GSM/GPRS/EDGE: 850: 824.2 MHz ~ 848.8 MHz 1900: 1850.2 MHz ~ 1909.8MHz WCDMA: Band V: 826.4 MHz ~ 846.6 MHz Band II: 1852.4 MHz ~ 1907.6 MHz Band IV: 1712.4 MHz ~ 1752.6 MHz CDMA2000: BC0: 824.70 MHz ~ 848.31 MHz
Rx Frequency	GSM/GPRS/EDGE: 850: 869.2 MHz ~ 893.8 MHz 1900: 1930.2 MHz ~ 1989.8 MHz WCDMA: Band V: 871.4 MHz ~ 891.6 MHz Band II: 1932.4 MHz ~ 1987.6 MHz Band IV: 2112.4 MHz ~ 2152.6 MHz CDMA2000: BC0: 869.70 MHz ~ 893.31 MHz
Maximum Output Power to Antenna	GSM/GPRS/EDGE: 850: 32.32 dBm 1900: 29.63 dBm WCDMA: Band V: 22.49 dBm Band II: 22.50 dBm Band IV: 22.46 dBm CDMA2000: BC0: 24.78 dBm
Antenna Type	PIFA Antenna
Antenna Gain	<Top Antenna> Cellular Band: -4.31 dBi PCS Band: -4.23 dBi AWS Band: -4.86 dBi <Bottom Antenna> Cellular Band: 2.65 dBi PCS Band: -2.18 dBi AWS Band: -3.15 dBi

1.5 Modification of EUT

No modifications are made to the EUT during all test items.



1.6 Maximum ERP/EIRP Power, Frequency Tolerance, and Emission Designator

FCC Rule	System	Type of Modulation	Maximum ERP/EIRP (W)	Frequency Tolerance (ppm)	Emission Designator
Part 22	GSM850 GSM	GMSK	0.2793	0.0191 ppm	248KGXW
Part 22	GSM850 EDGE class 8	8PSK	0.0659	0.0167 ppm	247KG7W
Part 22	WCDMA Band V RMC 12.2Kbps	QPSK	0.0329	0.0167 ppm	4M15F9W
Part 22	CDMA2000 BC0 1xRTT	QPSK	0.0319	0.0120 ppm	1M28F9W
Part 24	GSM1900 GPRS class 8	GMSK	1.1272	0.0090 ppm	243KGXW
Part 24	GSM1900 EDGE class 8	8PSK	0.5023	0.0064 ppm	249KG7W
Part 24	WCDMA Band II RMC 12.2Kbps	QPSK	0.2483	0.0059 ppm	4M16F9W
Part 27	WCDMA Band IV RMC 12.2Kbps	QPSK	0.1380	0.0052 ppm	4M15F9W



1.7 Testing Location

Sporton Lab is accredited to ISO 17025 by Taiwan Accreditation Foundation (TAF code : 1190) and the FCC designation No. TW1022 under the FCC 2.948(e) by Mutual Recognition Agreement (MRA) in FCC Test.

Test Site	SPORTON INTERNATIONAL INC.
Test Site Location	No. 52, Hwa Ya 1 st Rd., Hwa Ya Technology Park, Kwei-Shan District, Tao Yuan City, Taiwan, R.O.C. TEL: +886-3-327-3456 FAX: +886-3-328-4978
Test Site No.	Sporton Site No. TH03-HY

Test Site	SPORTON INTERNATIONAL INC.
Test Site Location	No.58, Aly. 75, Ln. 564, Wenhua 3rd Rd. Guishan Dist, Taoyuan City, Taiwan (R.O.C.) TEL: +886-3-327-0868 FAX: +886-3-327-0855
Test Site No.	Sporton Site No. 03CH11-HY

1.8 Applicable Standards

According to the specifications of the manufacturer, the EUT must comply with the requirements of the following standards:

- ♦ 47 CFR Part 2, 22(H), 24(E), 27(L)
- ♦ ANSI / TIA / EIA-603-D-2010
- ♦ FCC KDB 971168 D01 Power Meas. License Digital Systems v02r02

Remark:

1. All test items were verified and recorded according to the standards and without any deviation during the test.
2. This EUT has also been tested and complied with the requirements of FCC Part 15, Subpart B, recorded in a separate test report.



2 Test Configuration of Equipment Under Test

2.1 Test Mode

Antenna port conducted and radiated test items were performed according to KDB 971168 D01 Power Meas. License Digital Systems v02r02 with maximum output power.

Radiated measurements were performed with rotating EUT in different three orthogonal test planes to find the maximum emission.

Radiated emissions were investigated as following frequency range:

1. 30 MHz to 9000 MHz for GSM850 and WCDMA Band V and CDMA BC0 and BC10.
2. 30 MHz to 18000 MHz for WCDMA Band IV.
3. 30 MHz to 19000 MHz for GSM1900 and WCDMA Band II and CDMA BC1.

All modes and data rates and positions were investigated.

Test modes are chosen to be reported as the worst case configuration below:

Test Modes		
Band	Radiated TCs	Conducted TCs
GSM 850	<ul style="list-style-type: none"> ■ GSM Link ■ EDGE class 8 Link 	<ul style="list-style-type: none"> ■ GSM Link ■ EDGE class 8 Link
GSM 1900	<ul style="list-style-type: none"> ■ GPRS class 8 Link ■ EDGE class 8 Link 	<ul style="list-style-type: none"> ■ GPRS class 8 Link ■ EDGE class 8 Link
WCDMA Band V	<ul style="list-style-type: none"> ■ RMC 12.2Kbps Link 	<ul style="list-style-type: none"> ■ RMC 12.2Kbps Link
WCDMA Band II	<ul style="list-style-type: none"> ■ RMC 12.2Kbps Link 	<ul style="list-style-type: none"> ■ RMC 12.2Kbps Link
WCDMA Band IV	<ul style="list-style-type: none"> ■ RMC 12.2Kbps Link 	<ul style="list-style-type: none"> ■ RMC 12.2Kbps Link
CDMA BC0	<ul style="list-style-type: none"> ■ 1xRTT Link 	<ul style="list-style-type: none"> ■ 1xRTT Link

2.2 Connection Diagram of Test System

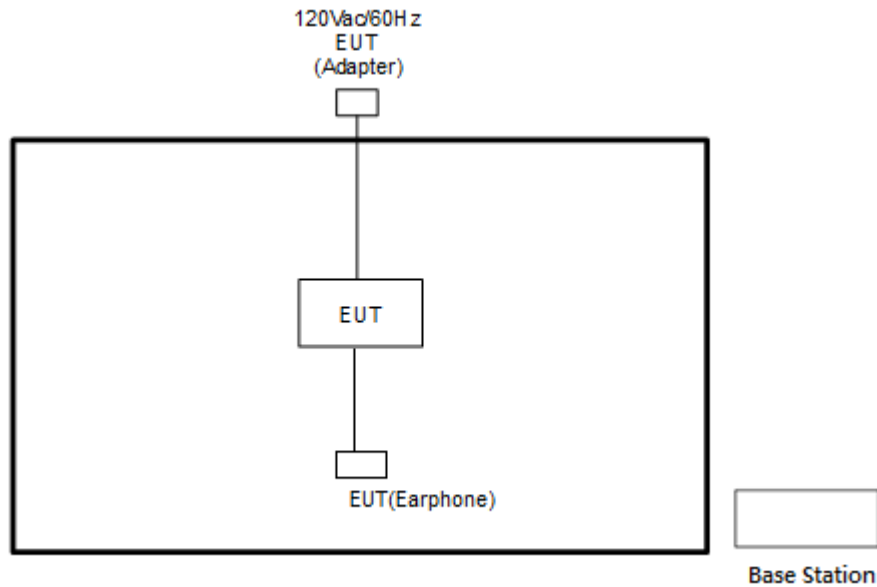

2.3 Support Unit used in test configuration

Item	Equipment	Trade Name	Model No.	FCC ID	Data Cable	Power Cord
1.	System Simulator	R&S	CMU 200	N/A	N/A	Unshielded, 1.8 m

2.4 Measurement Results Explanation Example

For all conducted test items:

The offset level is set in the spectrum analyzer to compensate the RF cable loss and attenuator factor between RF conducted output port and spectrum analyzer. With the offset compensation, the spectrum analyzer reading level will be exactly the RF output level.

The spectrum analyzer offset is derived from RF cable loss and attenuator factor.

Offset = RF cable loss + attenuator factor.

The following shows an offset computation example with RF cable loss 4.2 dB and a 10dB attenuator.

Example :

$$\begin{aligned} \text{Offset(dB)} &= \text{RF cable loss(dB)} + \text{attenuator factor(dB)} \\ &= 4.2 + 10 = 14.2 \text{ (dB)} \end{aligned}$$

3 Conducted Test Result

3.1 Measuring Instruments

See list of measuring instruments of this test report.

3.2 Test Setup

3.2.1 Conducted Output Power

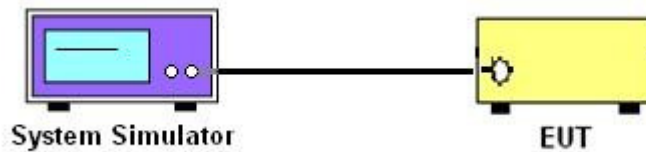

3.2.2 Peak-to-Average Ratio, Occupied Bandwidth, Conducted Band-Edge and Conducted Spurious Emission

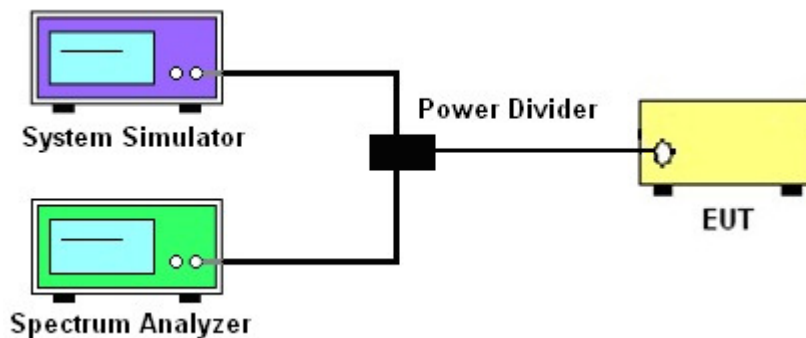

3.2.3 Frequency Stability

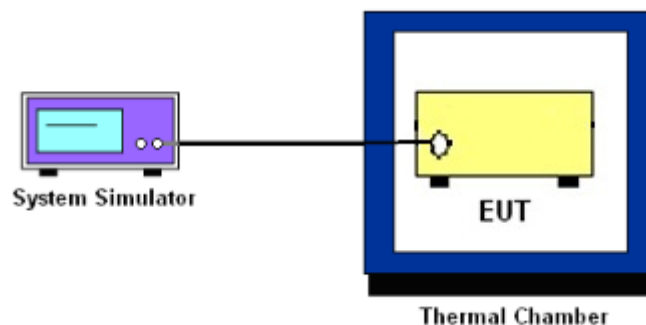

3.3 Test Result of Conducted Test

Please refer to Appendix A.



3.4 Conducted Output Power

3.4.1 Description of the Conducted Output Power

A system simulator was used to establish communication with the EUT. Its parameters were set to enforce EUT transmitting at the maximum power. The measured power in the radio frequency on the transmitter output terminals shall be reported.

3.4.2 Test Procedures

1. The transmitter output port was connected to the system simulator.
2. Set EUT at maximum power through system simulator.
3. Select lowest, middle, and highest channels for each band and different modulation.
4. Measure the maximum burst average power for GSM and maximum average power for other modulation signal.



3.5 Peak-to-Average Ratio

3.5.1 Description of the PAR Measurement

The peak-to-average ratio (PAR) of the transmission may not exceed 13 dB.

3.5.2 Test Procedures

1. The testing follows FCC KDB 971168 D01 v02r02 Section 5.7.1.
2. The EUT was connected to spectrum analyzer and system simulator via a power divider.
3. Set EUT to transmit at maximum output power.
4. When the duty cycle is less than 98%, then signal gating will be implemented on the spectrum analyzer by triggering from the system simulator.
5. Set the CCDF (Complementary Cumulative Distribution Function) option of the spectrum analyzer.
Record the maximum PAPR level associated with a probability of 0.1%.



3.6 99% Occupied Bandwidth and 26dB Bandwidth Measurement

3.6.1 Description of 99% Occupied Bandwidth and 26dB Bandwidth Measurement

The occupied bandwidth is the width of a frequency band such that, below the lower and above the upper frequency limits, the mean powers emitted are each equal to a specified percentage 0.5% of the total mean transmitted power.

The 26 dB emission bandwidth is defined as the frequency range between two points, one above and one below the carrier frequency, at which the spectral density of the emission is attenuated 26 dB below the maximum in-band spectral density of the modulated signal. Spectral density (power per unit bandwidth) is to be measured with a detector of resolution bandwidth equal to approximately 1.0% of the emission bandwidth.

3.6.2 Test Procedures

1. The testing follows FCC KDB 971168 v02r02 Section 4.2.
2. The EUT was connected to spectrum analyzer and system simulator via a power divider.
3. The spectrum analyzer center frequency is set to the nominal EUT channel center frequency. The span range for the spectrum analyzer shall be between two and five times the anticipated OBW.
4. The nominal resolution bandwidth (RBW) shall be in the range of 1 to 5 % of the anticipated OBW, and the VBW shall be at least 3 times the RBW.
5. Set the detection mode to peak, and the trace mode to max hold.
6. Determine the reference value: Set the EUT to transmit a modulated signal. Allow the trace to stabilize. Set the spectrum analyzer marker to the highest level of the displayed trace.
(this is the reference value)
7. Determine the “-26 dB down amplitude” as equal to (Reference Value – X).
8. Place two markers, one at the lowest and the other at the highest frequency of the envelope of the spectral display such that each marker is at or slightly below the “-X dB down amplitude” determined in step 6. If a marker is below this “-X dB down amplitude” value it shall be placed as close as possible to this value. The OBW is the positive frequency difference between the two markers.
9. Use the 99 % power bandwidth function of the spectrum analyzer and report the measured bandwidth.



3.7 Conducted Band Edge

3.7.1 Description of Conducted Band Edge Measurement

The power of any emission outside of the authorized operating frequency ranges must be lower than the transmitter power (P) by a factor of at least $43 + 10 \log (P)$ dB.

3.7.2 Test Procedures

1. The testing follows FCC KDB 971168 D01 v02r02 Section 6.0.
2. The EUT was connected to the spectrum analyzer and system simulator via a power divider.
3. The RF output of EUT was connected to the spectrum analyzer by an RF cable and attenuator. The path loss was compensated to the results for each measurement.
4. The band edges of low and high channels for the highest RF powers were measured.
5. The RF fundamental frequency should be excluded against the limit line in the operating frequency band.
6. The limit line is derived from $43 + 10\log(P)$ dB below the transmitter power P(Watts)
= $P(W) - [43 + 10\log(P)]$ (dB)
= $[30 + 10\log(P)]$ (dBm) - $[43 + 10\log(P)]$ (dB)
= -13dBm.



3.8 Conducted Spurious Emission

3.8.1 Description of Conducted Spurious Emission Measurement

The power of any emission outside of the authorized operating frequency ranges must be lower than the transmitter power (P) by a factor of at least $43 + 10 \log (P)$ dB.

It is measured by means of a calibrated spectrum analyzer and scanned from 30 MHz up to a frequency including its 10th harmonic.

3.8.2 Test Procedures

1. The testing follows FCC KDB 971168 D01 v02r02 Section 6.0.
2. The EUT was connected to the spectrum analyzer and system simulator via a power divider.
3. The RF output of EUT was connected to the spectrum analyzer by an RF cable and attenuator. The path loss was compensated to the results for each measurement.
4. The middle channel for the highest RF power within the transmitting frequency was measured.
5. The conducted spurious emission for the whole frequency range was taken.
6. The RF fundamental frequency should be excluded against the limit line in the operating frequency band.
7. The limit line is derived from $43 + 10\log(P)$ dB below the transmitter power P(Watts)
= $P(W) - [43 + 10\log(P)]$ (dB)
= $[30 + 10\log(P)]$ (dBm) - $[43 + 10\log(P)]$ (dB)
= -13dBm.



3.9 Frequency Stability

3.9.1 Description of Frequency Stability Measurement

The frequency stability shall be measured by variation of ambient temperature and variation of primary supply voltage to ensure that the fundamental emission stays within the authorized frequency block. The frequency stability of the transmitter shall be maintained within $\pm 0.00025\%$ ($\pm 2.5\text{ppm}$) of the center frequency.

3.9.2 Test Procedures for Temperature Variation

1. The testing follows FCC KDB 971168 D01 v02r02 Section 9.0.
2. The EUT was set up in the thermal chamber and connected with the system simulator.
3. With power OFF, the temperature was decreased to -30°C and the EUT was stabilized before testing. Power was applied and the maximum change in frequency was recorded within one minute.
4. With power OFF, the temperature was raised in 10°C steps up to 50°C . The EUT was stabilized at each step for at least half an hour. Power was applied and the maximum frequency change was recorded within one minute.

3.9.3 Test Procedures for Voltage Variation

1. The testing follows FCC KDB 971168 D01 v02r02 Section 9.0.
2. The EUT was placed in a temperature chamber at $20\pm 5^{\circ}\text{C}$ and connected with the system simulator.
3. The power supply voltage to the EUT was varied from 85% to 115% of the nominal value measured at the input to the EUT.
4. The variation in frequency was measured for the worst case.

4 Radiated Test Items

4.1 Measuring Instruments

See list of measuring instruments of this test report.

4.2 Test Setup

4.2.1 For radiated test from 30MHz to 1GHz

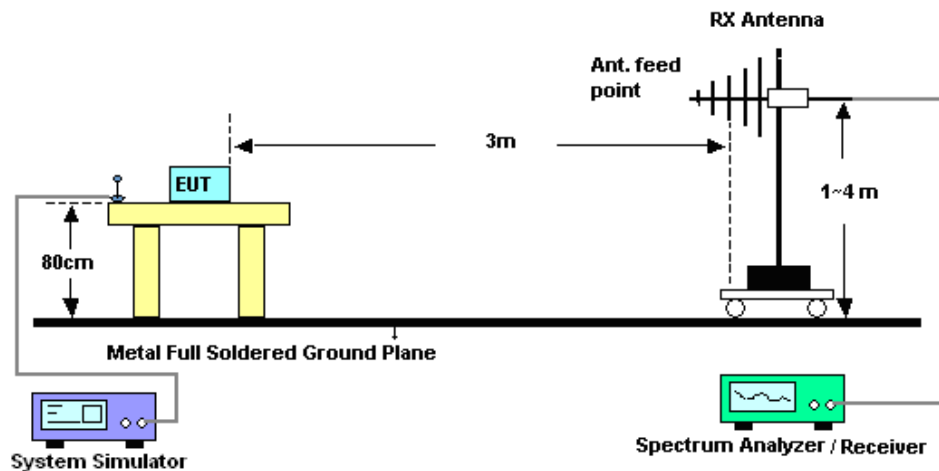

4.2.2 For radiated test above 1GHz

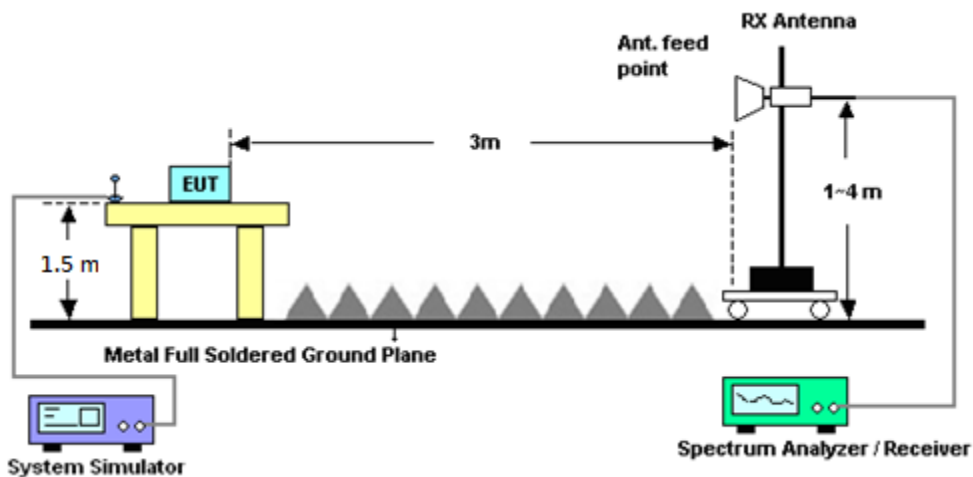

4.3 Test Result of Radiated Test

Please refer to Appendix B.



4.4 Effective Radiated Power and Effective Isotropic Radiated Power Measurement

4.4.1 Description of the ERP/EIRP Measurement

The substitution method, in ANSI / TIA / EIA-603-D-2010, was used for ERP/EIRP measurement, and the spectrum analyzer configuration follows KDB 971168 D01 Power Meas. License Digital Systems v02r02. The ERP of mobile transmitters must not exceed 7 Watts (Cellular Band) and the EIRP of mobile transmitters are limited to 2 Watts (PCS Band) and 1 Watts (AWS Band).

4.4.2 Test Procedures

1. The testing follows FCC KDB 971168 D01 v02r02 Section 5.2.1. (for CDMA/WCDMA), Section 5.2.2.2 (for GSM/GPRS/EDGE) and ANSI / TIA-603-D-2010 Section 2.2.17.
2. The EUT was placed on a non-conductive rotating platform (0.8 meters for frequency below 1GHz and 1.5 meter for frequency above 1GHz) in a semi-anechoic chamber. The radiated emission at the fundamental frequency was measured at 3 m with a test antenna and a spectrum analyzer with RMS detector per section 5. of KDB 971168 D01.
3. During the measurement, the system simulator parameters were set to force the EUT transmitting at maximum output power. The maximum emission was recorded from analyzer power level (LVL) from the 360 degrees rotation of the turntable and the test antenna raised and lowered over a range from 1 to 4 meters in both horizontally and vertically polarized orientations.
4. Effective Isotropic Radiated Power (EIRP) was measured by substitution method according to TIA/EIA-603-D. The EUT was replaced by the substitution antenna at same location, and then a known power from S.G. was applied into the dipole antenna through a Tx cable, and then recorded the maximum Analyzer reading through raised and lowered the test antenna. The correction factor (in dB) = S.G. - Tx Cable loss + Substitution antenna gain - Analyzer reading. Then the EUT's EIRP was calculated with the correction factor, $EIRP = LVL + \text{Correction factor}$ and $ERP = EIRP - 2.15$. Take the record of the output power at substitution antenna.



	GSM/GPRS/EDGE	WCDMA/HSPA
SPAN	500kHz	10MHz
RBW	10kHz	100kHz
VBW	30kHz	300kHz
Detector	RMS	RMS
Trace	Average	Average
Average Type	Power	Power
Sweep Count	100	100



4.5 Field Strength of Spurious Radiation Measurement

4.5.1 Description of Field Strength of Spurious Radiated Measurement

The power of any emission outside of the authorized operating frequency ranges must be attenuated below the transmitter power (P) by a factor of at least $43 + 10 \log (P)$ dB. The spectrum is scanned from 30 MHz up to a frequency including its 10th harmonic.

4.5.2 Test Procedures

1. The testing follows FCC KDB 971168 D01 v02r02 Section 5.8 and ANSI / TIA-603-D-2010 Section 2.2.12.
2. The EUT was placed on a rotatable wooden table 0.8 meters for frequency below 1GHz and 1.5 meter for frequency above 1GHz above the ground.
3. The EUT was set 3 meters from the receiving antenna, which was mounted on the antenna tower.
4. The table was rotated 360 degrees to determine the position of the highest spurious emission.
5. The height of the receiving antenna is varied between one meter and four meters to search for the maximum spurious emission for both horizontal and vertical polarizations.
6. Make the measurement with the spectrum analyzer's RBW = 1MHz, VBW = 3MHz, taking record of maximum spurious emission.
7. A horn antenna was substituted in place of the EUT and was driven by a signal generator.
8. Tune the output power of signal generator to the same emission level with EUT maximum spurious emission.
9. Taking the record of output power at antenna port.
10. Repeat step 7 to step 8 for another polarization.
11. $EIRP \text{ (dBm)} = S.G. \text{ Power} - Tx \text{ Cable Loss} + Tx \text{ Antenna Gain}$
12. $ERP \text{ (dBm)} = EIRP - 2.15$
13. The RF fundamental frequency should be excluded against the limit line in the operating frequency band.
14. The limit line is derived from $43 + 10\log(P)$ dB below the transmitter power P(Watts)
 $= P(W) - [43 + 10\log(P)] \text{ (dB)}$
 $= [30 + 10\log(P)] \text{ (dBm)} - [43 + 10\log(P)] \text{ (dB)}$
 $= -13\text{dBm}.$



5 List of Measuring Equipment

Instrument	Manufacturer	Model No.	Serial No.	Characteristics	Calibration Date	Test Date	Due Date	Remark
Spectrum Analyzer	Rohde & Schwarz	FSP30	101329	9kHz~30GHz	Jun. 27, 2016	Jul. 07, 2016 ~ Jul. 11, 2016	Jun. 26, 2017	Conducted (TH03-HY)
Temperature Chamber	ESPEC	SU-641	92013721	-30°C ~70°C	Nov. 20, 2015	Jul. 07, 2016 ~ Jul. 11, 2016	Nov. 19, 2016	Conducted (TH03-HY)
Programmable Power Supply	GW Instek	PSS-2005	EL883644	Voltage:0~20V;Current:0~5A	Nov. 26, 2015	Jul. 07, 2016 ~ Jul. 11, 2016	Nov. 25, 2016	Conducted (TH03-HY)
Base Station(Measu	Rohde & Schwarz	CMU200	117995	GSM / GPRS / WCDMA / CDMA	Jul. 26, 2015	Jul. 07, 2016 ~ Jul. 11, 2016	Jul. 25, 2016	Conducted (TH03-HY)
Amplifier	SONOMA	310N	187312	9kHz~1GHz	Nov. 20, 2015	Jul. 13, 2016 ~ Jul. 28, 2016	Nov. 19, 2016	Radiation (03CH11-HY)
Bilog Antenna	TESEQ	CBL 6111D	35414	30MHz~1GHz	Nov. 17, 2015	Jul. 13, 2016 ~ Jul. 28, 2016	Nov. 16, 2016	Radiation (03CH11-HY)
Horn Antenna	SCHWARZBECK	BBHA 9120 D	9120D-1326	1GHz ~ 18GHz	Oct. 08, 2015	Jul. 13, 2016 ~ Jul. 28, 2016	Oct. 07, 2016	Radiation (03CH11-HY)
Spectrum Analyzer	Keysight	N9010A	MY54200486	10Hz ~ 44GHZ	Sep. 24, 2015	Jul. 13, 2016 ~ Jul. 28, 2016	Sep. 23, 2016	Radiation (03CH11-HY)
Antenna Mast	EMEC	AM-BS-450 0-B	N/A	1~4m	N/A	Jul. 13, 2016 ~ Jul. 28, 2016	N/A	Radiation (03CH11-HY)
Turn Table	EMEC	TT 2000	N/A	0~360 Degree	N/A	Jul. 13, 2016 ~ Jul. 28, 2016	N/A	Radiation (03CH11-HY)
SHF-EHF Horn Antenna	SCHWARZBECK	BBHA 9170	BBHA9170576	18GHz ~ 40GHz	Apr. 15, 2016	Jul. 13, 2016 ~ Jul. 28, 2016	Apr. 14, 2017	Radiation (03CH11-HY)
Bilog Antenna	TESEQ	CBL 6111D	40103	30MHz to 1GHz	Jan. 13, 2016	Jul. 13, 2016 ~ Jul. 28, 2016	Jan. 12, 2017	Radiation (03CH11-HY)
Horn Antenna	SCHWARZBECK	BBHA 9120 D	9120D-1522	1G~18GHz	Mar. 31, 2016	Jul. 13, 2016 ~ Jul. 28, 2016	Mar. 30, 2017	Radiation (03CH11-HY)
Preamplifier	MITEQ	TTA0204	1872107	2GHz~40GHz	Feb. 15, 2016	Jul. 13, 2016 ~ Jul. 28, 2016	Feb. 14, 2017	Radiation (03CH11-HY)
Signal Generator	Rohde & Schwarz	SMF100A	101107	100kHz~40GHz	May 19, 2016	Jul. 13, 2016 ~ Jul. 28, 2016	May 18, 2017	Radiation (03CH11-HY)
Loop Antenna	Rohde & Schwarz	HFH2-Z2	100315	9 kHz~30 MHz	Sep. 02, 2015	Jul. 13, 2016 ~ Jul. 28, 2016	Sep. 01, 2016	Radiation (03CH11-HY)



6 Uncertainty of Evaluation

Uncertainty of Radiated Emission Measurement (30 MHz ~ 1000 MHz)

Measuring Uncertainty for a Level of Confidence of 95% ($U = 2Uc(y)$)	3.37
---	------

Uncertainty of Radiated Emission Measurement (1 GHz ~ 40 GHz)

Measuring Uncertainty for a Level of Confidence of 95% ($U = 2Uc(y)$)	4.03
---	------



Appendix A. Test Results of Conducted Test

Conducted Output Power(Average power)

Conducted Power (*Unit: dBm)						
Band	GSM850			GSM1900		
Channel	128	189	251	512	661	810
Frequency	824.2	836.4	848.8	1850.2	1880.0	1909.8
GSM	31.88	32.05	32.20	29.57	29.28	29.06
GPRS class 8	32.03	32.24	32.32	29.63	29.33	29.09
GPRS class 10	29.31	29.30	29.37	27.71	27.75	27.80
GPRS class 11	28.96	28.92	28.91	27.34	27.42	27.45
GPRS class 12	26.49	26.43	26.50	25.14	25.24	25.41
EGPRS class 8	27.28	27.26	27.23	25.98	25.97	25.99
EGPRS class 10	27.05	27.02	27.01	25.73	25.72	25.77
EGPRS class 11	26.81	26.78	26.68	25.50	25.43	25.38
EGPRS class 12	26.50	26.46	26.43	24.73	24.67	24.77

Conducted Power (*Unit: dBm)									
Band	WCDMA Band V			WCDMA Band II			WCDMA Band IV		
Channel	4132	4182	4233	9262	9400	9538	1312	1413	1513
Frequency	826.4	836.4	846.6	1852.4	1880	1907.6	1712.4	1732.6	1752.6
RMC 12.2K	22.40	22.35	22.49	22.08	22.28	22.50	22.46	22.38	22.39
HSDPA Subtest-1	21.30	21.35	21.48	21.09	21.29	21.53	21.15	21.03	21.04
HSDPA Subtest-2	21.27	21.32	21.48	21.07	21.30	21.52	21.13	21.00	21.09
HSDPA Subtest-3	20.82	20.87	21.01	20.60	20.81	21.05	20.67	20.59	20.54
HSDPA Subtest-4	20.80	20.86	21.01	20.55	20.80	21.04	20.66	20.58	20.56
HSUPA Subtest-1	21.38	21.32	21.47	21.09	21.27	21.51	21.04	21.02	21.00
HSUPA Subtest-2	19.35	19.36	19.50	19.10	19.30	19.52	19.07	19.02	19.13
HSUPA Subtest-3	20.39	20.34	20.48	20.07	20.27	20.53	20.11	20.03	20.10
HSUPA Subtest-4	19.33	19.38	19.51	19.10	19.30	19.53	19.07	19.02	19.11
HSUPA Subtest-5	21.33	21.30	21.52	21.07	21.38	21.52	21.13	21.05	21.07



Conducted Power (*Unit: dBm)			
Band	CDMA 2000 BC0		
Channel	1013	384	777
Frequency	824.7	836.52	848.31
1xRTT RC1 SO55	24.54	24.40	24.74
1xRTT RC3 SO55	24.51	24.38	24.76
1xRTT RC3 SO32 (+ F-SCH)	24.50	24.41	24.78
1xRTT RC3 SO32 (+SCH)	24.51	24.37	24.75
1xEVDO RTAP 153.6Kbps	24.48	24.40	24.72
1xEVDO RETAP 4096Bits	24.52	24.40	24.70



A1. GSM

Peak-to-Average Ratio

Mode	GSM850		Limit: 13dB
Mod.	GPRS class 8	EDGE class 8	Result
Lowest CH	0.24	3.20	PASS
Middle CH	0.20	3.24	
Highest CH	0.24	3.12	

Mode	GSM1900		Limit: 13dB
Mod.	GPRS class 8	EDGE class 8	Result
Lowest CH	0.24	3.08	PASS
Middle CH	0.24	3.16	
Highest CH	0.24	2.96	

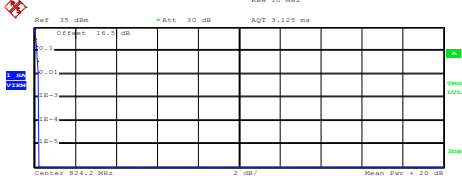
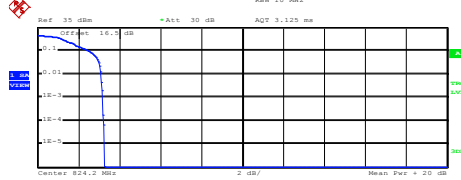
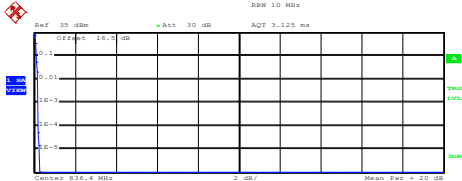
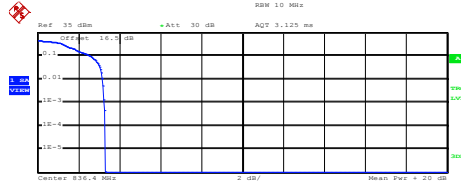
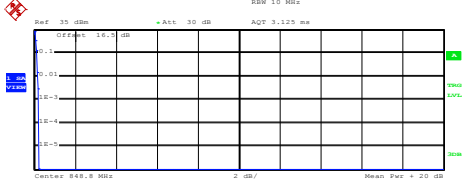
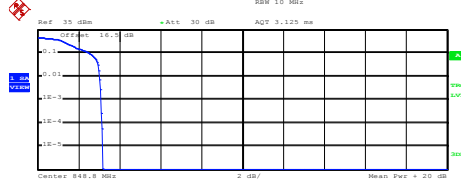

GSM850 (GPRS class 8)	GSM850 (EDGE class 8)																
<p style="text-align: center;">Lowest Channel</p>  <p>Complementary Cumulative Distribution Function (100000 samples) Trace 1 Mean 32.64 dBm Peak 32.85 dBm Crest 0.22 dB</p> <table border="1"> <tr><td>10 %</td><td>0.16 dB</td></tr> <tr><td>1 %</td><td>0.20 dB</td></tr> <tr><td>.1 %</td><td>0.24 dB</td></tr> <tr><td>.01 %</td><td>0.24 dB</td></tr> </table> <p>Date: 7.JUL.2016 17:48:30</p>	10 %	0.16 dB	1 %	0.20 dB	.1 %	0.24 dB	.01 %	0.24 dB	<p style="text-align: center;">Lowest Channel</p>  <p>Complementary Cumulative Distribution Function (100000 samples) Trace 1 Mean 26.71 dBm Peak 29.96 dBm Crest 3.26 dB</p> <table border="1"> <tr><td>10 %</td><td>2.52 dB</td></tr> <tr><td>1 %</td><td>3.08 dB</td></tr> <tr><td>.1 %</td><td>3.20 dB</td></tr> <tr><td>.01 %</td><td>3.24 dB</td></tr> </table> <p>Date: 7.JUL.2016 17:36:19</p>	10 %	2.52 dB	1 %	3.08 dB	.1 %	3.20 dB	.01 %	3.24 dB
10 %	0.16 dB																
1 %	0.20 dB																
.1 %	0.24 dB																
.01 %	0.24 dB																
10 %	2.52 dB																
1 %	3.08 dB																
.1 %	3.20 dB																
.01 %	3.24 dB																
<p style="text-align: center;">Middle Channel</p>  <p>Complementary Cumulative Distribution Function (100000 samples) Trace 1 Mean 32.18 dBm Peak 32.43 dBm Crest 0.25 dB</p> <table border="1"> <tr><td>10 %</td><td>0.12 dB</td></tr> <tr><td>1 %</td><td>0.20 dB</td></tr> <tr><td>.1 %</td><td>0.20 dB</td></tr> <tr><td>.01 %</td><td>0.20 dB</td></tr> </table> <p>Date: 7.JUL.2016 17:48:57</p>	10 %	0.12 dB	1 %	0.20 dB	.1 %	0.20 dB	.01 %	0.20 dB	<p style="text-align: center;">Middle Channel</p>  <p>Complementary Cumulative Distribution Function (100000 samples) Trace 1 Mean 26.38 dBm Peak 29.68 dBm Crest 3.29 dB</p> <table border="1"> <tr><td>10 %</td><td>2.60 dB</td></tr> <tr><td>1 %</td><td>3.16 dB</td></tr> <tr><td>.1 %</td><td>3.24 dB</td></tr> <tr><td>.01 %</td><td>3.32 dB</td></tr> </table> <p>Date: 7.JUL.2016 17:37:11</p>	10 %	2.60 dB	1 %	3.16 dB	.1 %	3.24 dB	.01 %	3.32 dB
10 %	0.12 dB																
1 %	0.20 dB																
.1 %	0.20 dB																
.01 %	0.20 dB																
10 %	2.60 dB																
1 %	3.16 dB																
.1 %	3.24 dB																
.01 %	3.32 dB																
<p style="text-align: center;">Highest Channel</p>  <p>Complementary Cumulative Distribution Function (100000 samples) Trace 1 Mean 31.80 dBm Peak 32.01 dBm Crest 0.21 dB</p> <table border="1"> <tr><td>10 %</td><td>0.12 dB</td></tr> <tr><td>1 %</td><td>0.16 dB</td></tr> <tr><td>.1 %</td><td>0.24 dB</td></tr> <tr><td>.01 %</td><td>0.24 dB</td></tr> </table> <p>Date: 7.JUL.2016 17:49:32</p>	10 %	0.12 dB	1 %	0.16 dB	.1 %	0.24 dB	.01 %	0.24 dB	<p style="text-align: center;">Highest Channel</p>  <p>Complementary Cumulative Distribution Function (100000 samples) Trace 1 Mean 26.44 dBm Peak 29.61 dBm Crest 3.16 dB</p> <table border="1"> <tr><td>10 %</td><td>2.52 dB</td></tr> <tr><td>1 %</td><td>3.04 dB</td></tr> <tr><td>.1 %</td><td>3.12 dB</td></tr> <tr><td>.01 %</td><td>3.16 dB</td></tr> </table> <p>Date: 7.JUL.2016 17:37:41</p>	10 %	2.52 dB	1 %	3.04 dB	.1 %	3.12 dB	.01 %	3.16 dB
10 %	0.12 dB																
1 %	0.16 dB																
.1 %	0.24 dB																
.01 %	0.24 dB																
10 %	2.52 dB																
1 %	3.04 dB																
.1 %	3.12 dB																
.01 %	3.16 dB																



GSM1900 (GPRS class 8)	GSM1900 (EDGE class 8)																
<p align="center">Lowest Channel</p> <p>Ref: 35 dBm RBW: 10 MHz AQT: 3.125 ms Att: 30 dB</p> <p>Center: 1.8502 GHz 2 dB/ Mean Pwr: +20 dB</p> <p>Complementary Cumulative Distribution Function (100000 samples) Trace 1 Mean: 28.34 dBm Peak: 28.55 dBm Crest: 0.21 dB</p> <table border="1"> <tr><td>10 %</td><td>0.12 dB</td></tr> <tr><td>1 %</td><td>0.20 dB</td></tr> <tr><td>.1 %</td><td>0.24 dB</td></tr> <tr><td>.01 %</td><td>0.24 dB</td></tr> </table> <p>Date: 7.JUL.2016 16:33:21</p>	10 %	0.12 dB	1 %	0.20 dB	.1 %	0.24 dB	.01 %	0.24 dB	<p align="center">Lowest Channel</p> <p>Ref: 35 dBm RBW: 10 MHz AQT: 3.125 ms Att: 30 dB</p> <p>Center: 1.8502 GHz 2 dB/ Mean Pwr: +20 dB</p> <p>Complementary Cumulative Distribution Function (100000 samples) Trace 1 Mean: 25.20 dBm Peak: 28.34 dBm Crest: 3.14 dB</p> <table border="1"> <tr><td>10 %</td><td>2.52 dB</td></tr> <tr><td>1 %</td><td>3.00 dB</td></tr> <tr><td>.1 %</td><td>3.08 dB</td></tr> <tr><td>.01 %</td><td>3.12 dB</td></tr> </table> <p>Date: 7.JUL.2016 17:13:20</p>	10 %	2.52 dB	1 %	3.00 dB	.1 %	3.08 dB	.01 %	3.12 dB
10 %	0.12 dB																
1 %	0.20 dB																
.1 %	0.24 dB																
.01 %	0.24 dB																
10 %	2.52 dB																
1 %	3.00 dB																
.1 %	3.08 dB																
.01 %	3.12 dB																
<p align="center">Middle Channel</p> <p>Ref: 35 dBm RBW: 10 MHz AQT: 3.125 ms Att: 30 dB</p> <p>Center: 1.88 GHz 2 dB/ Mean Pwr: +20 dB</p> <p>Complementary Cumulative Distribution Function (100000 samples) Trace 1 Mean: 25.43 dBm Peak: 25.66 dBm Crest: 0.23 dB</p> <table border="1"> <tr><td>10 %</td><td>0.12 dB</td></tr> <tr><td>1 %</td><td>0.20 dB</td></tr> <tr><td>.1 %</td><td>0.24 dB</td></tr> <tr><td>.01 %</td><td>0.24 dB</td></tr> </table> <p>Date: 7.JUL.2016 16:34:25</p>	10 %	0.12 dB	1 %	0.20 dB	.1 %	0.24 dB	.01 %	0.24 dB	<p align="center">Middle Channel</p> <p>Ref: 35 dBm RBW: 10 MHz AQT: 3.125 ms Att: 30 dB</p> <p>Center: 1.88 GHz 2 dB/ Mean Pwr: +20 dB</p> <p>Complementary Cumulative Distribution Function (100000 samples) Trace 1 Mean: 25.28 dBm Peak: 28.55 dBm Crest: 3.27 dB</p> <table border="1"> <tr><td>10 %</td><td>2.52 dB</td></tr> <tr><td>1 %</td><td>3.08 dB</td></tr> <tr><td>.1 %</td><td>3.16 dB</td></tr> <tr><td>.01 %</td><td>3.28 dB</td></tr> </table> <p>Date: 7.JUL.2016 17:13:55</p>	10 %	2.52 dB	1 %	3.08 dB	.1 %	3.16 dB	.01 %	3.28 dB
10 %	0.12 dB																
1 %	0.20 dB																
.1 %	0.24 dB																
.01 %	0.24 dB																
10 %	2.52 dB																
1 %	3.08 dB																
.1 %	3.16 dB																
.01 %	3.28 dB																
<p align="center">Highest Channel</p> <p>Ref: 35 dBm RBW: 10 MHz AQT: 3.125 ms Att: 30 dB</p> <p>Center: 1.9098 GHz 2 dB/ Mean Pwr: +20 dB</p> <p>Complementary Cumulative Distribution Function (100000 samples) Trace 1 Mean: 29.05 dBm Peak: 29.26 dBm Crest: 0.21 dB</p> <table border="1"> <tr><td>10 %</td><td>0.12 dB</td></tr> <tr><td>1 %</td><td>0.20 dB</td></tr> <tr><td>.1 %</td><td>0.24 dB</td></tr> <tr><td>.01 %</td><td>0.24 dB</td></tr> </table> <p>Date: 7.JUL.2016 16:36:14</p>	10 %	0.12 dB	1 %	0.20 dB	.1 %	0.24 dB	.01 %	0.24 dB	<p align="center">Highest Channel</p> <p>Ref: 35 dBm RBW: 10 MHz AQT: 3.125 ms Att: 30 dB</p> <p>Center: 1.9098 GHz 2 dB/ Mean Pwr: +20 dB</p> <p>Complementary Cumulative Distribution Function (100000 samples) Trace 1 Mean: 25.88 dBm Peak: 28.90 dBm Crest: 3.03 dB</p> <table border="1"> <tr><td>10 %</td><td>2.40 dB</td></tr> <tr><td>1 %</td><td>2.88 dB</td></tr> <tr><td>.1 %</td><td>2.96 dB</td></tr> <tr><td>.01 %</td><td>3.04 dB</td></tr> </table> <p>Date: 7.JUL.2016 17:14:23</p>	10 %	2.40 dB	1 %	2.88 dB	.1 %	2.96 dB	.01 %	3.04 dB
10 %	0.12 dB																
1 %	0.20 dB																
.1 %	0.24 dB																
.01 %	0.24 dB																
10 %	2.40 dB																
1 %	2.88 dB																
.1 %	2.96 dB																
.01 %	3.04 dB																



26dB Bandwidth

Mode	GSM850	
Mod.	GPRS class 8	EDGE class 8
Lowest CH	0.304	0.314
Middle CH	0.315	0.300
Highest CH	0.308	0.299

Mode	GSM1900	
Mod.	GPRS class 8	EDGE class 8
Lowest CH	0.312	0.297
Middle CH	0.299	0.289
Highest CH	0.317	0.303

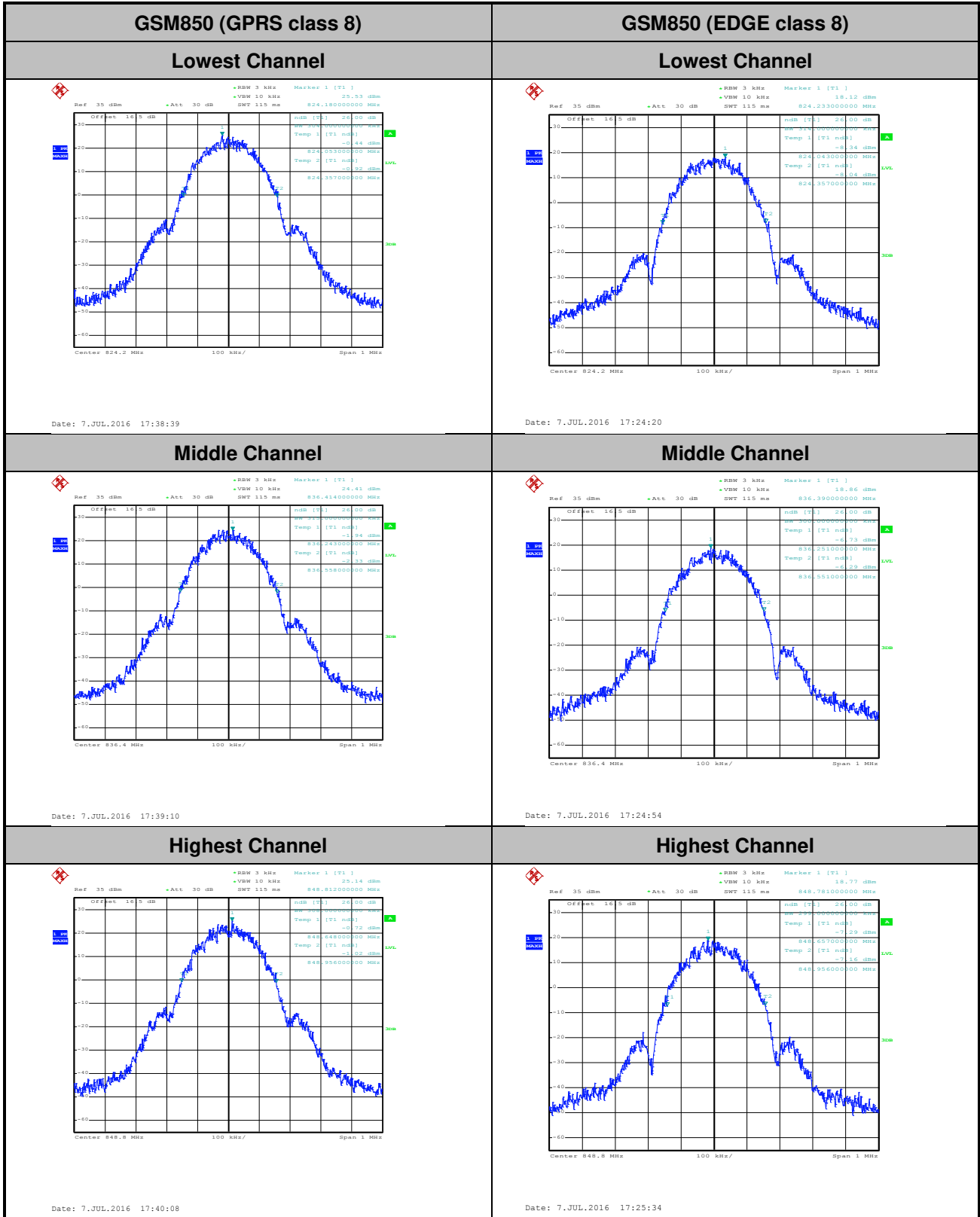

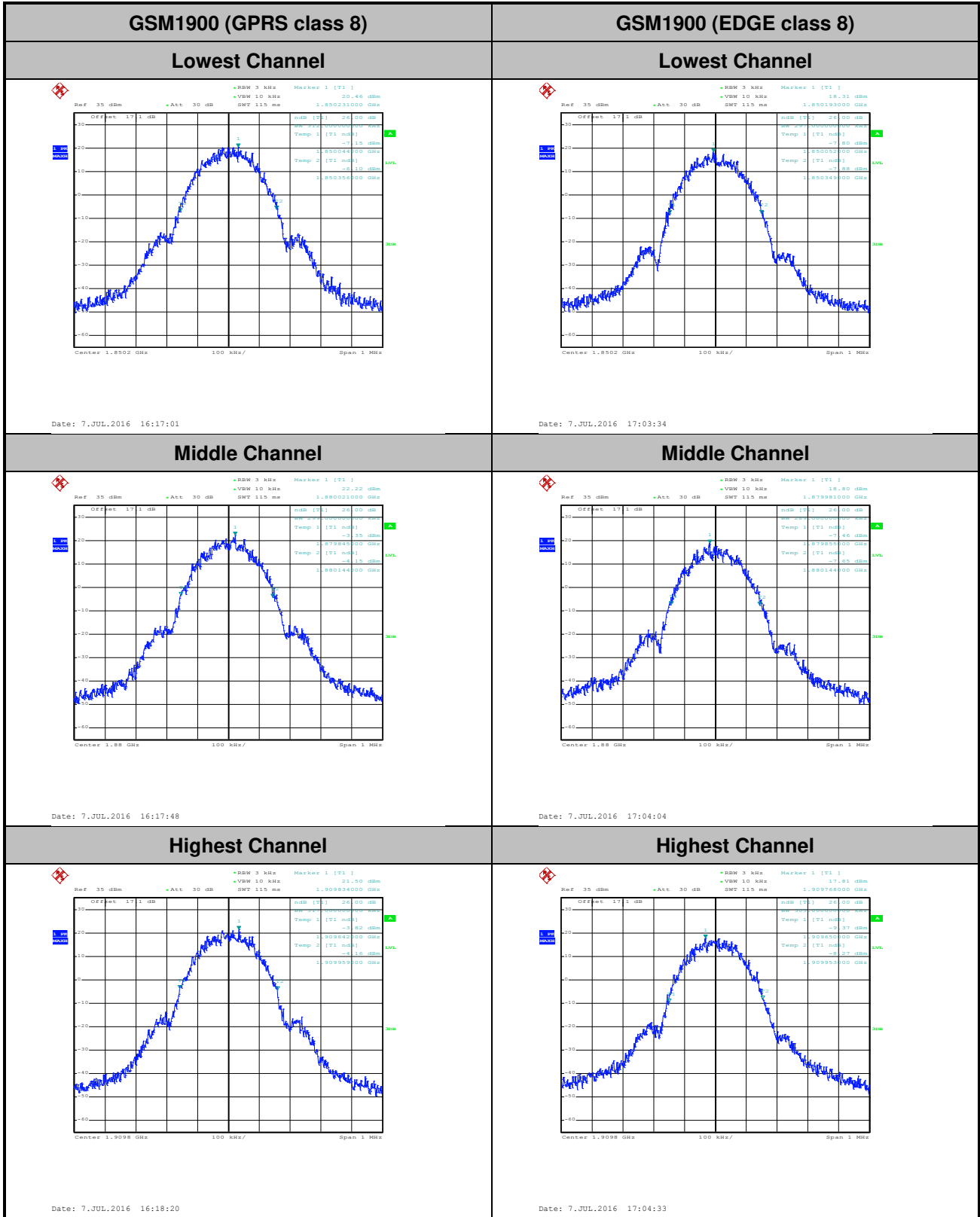



Occupied Bandwidth

Mode	GSM850	
Mod.	GPRS class 8	EDGE class 8
Lowest CH	0.246	0.244
Middle CH	0.244	0.247
Highest CH	0.248	0.244

Mode	GSM1900	
Mod.	GPRS class 8	EDGE class 8
Lowest CH	0.243	0.248
Middle CH	0.242	0.247
Highest CH	0.242	0.249

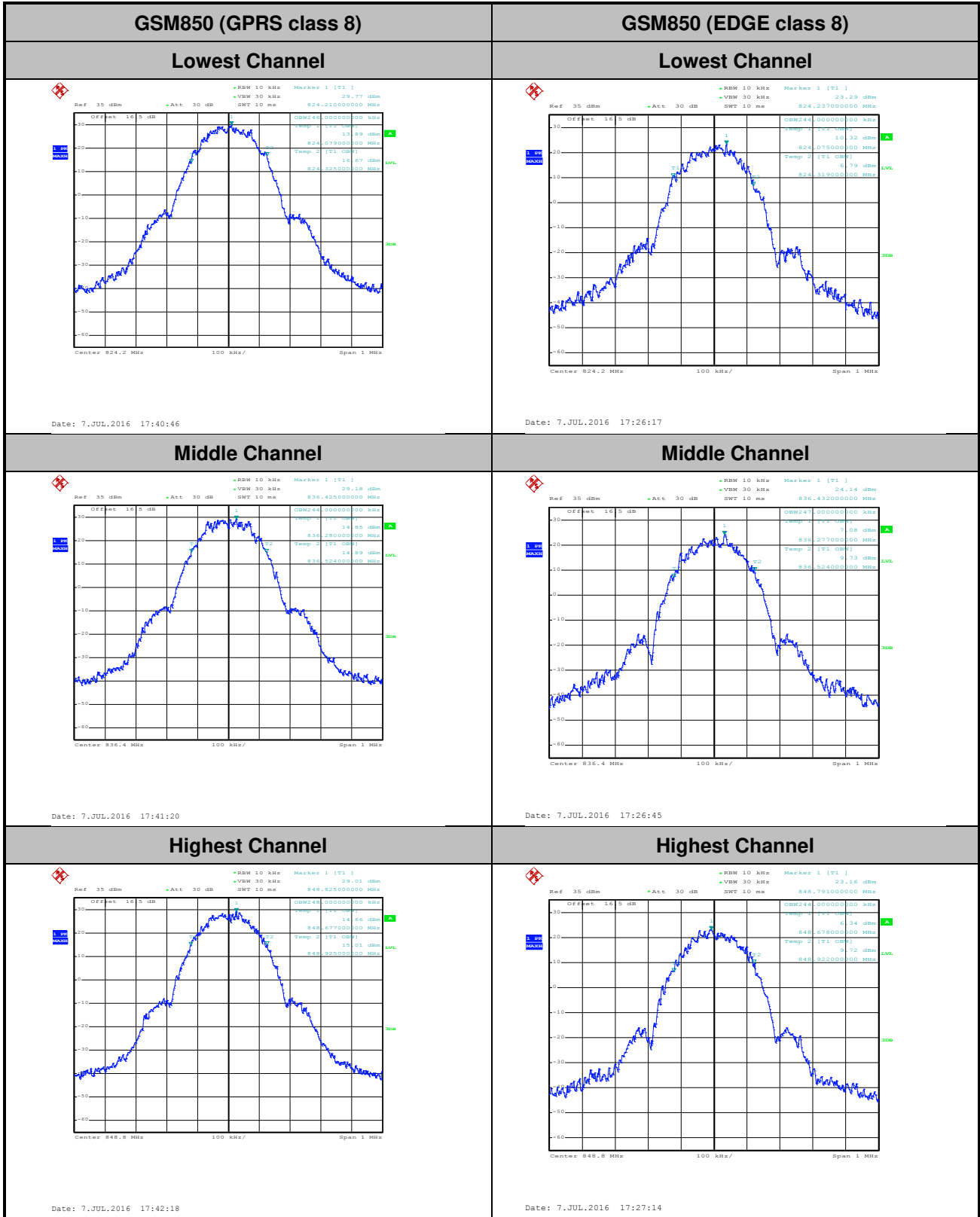

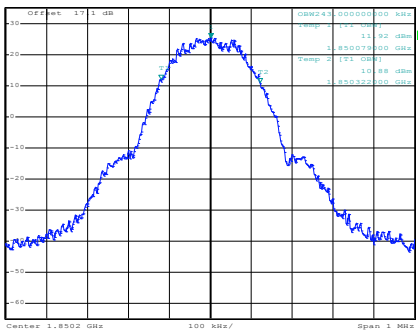
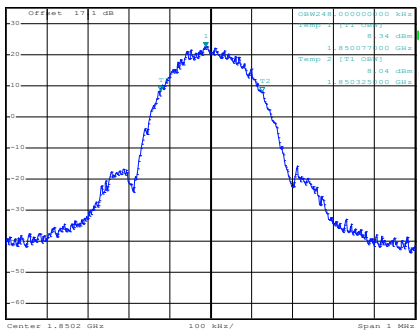
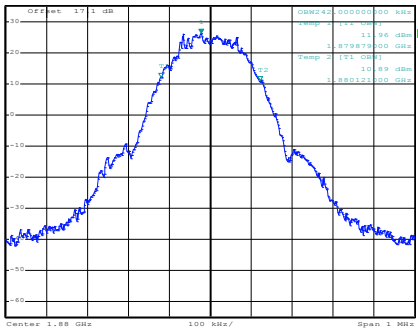
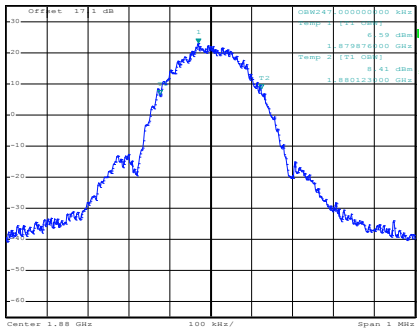
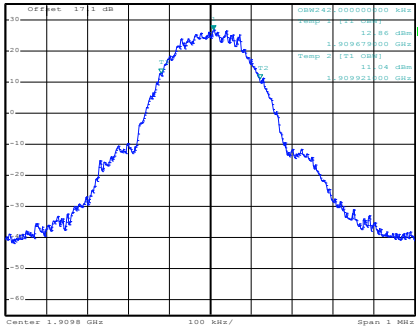
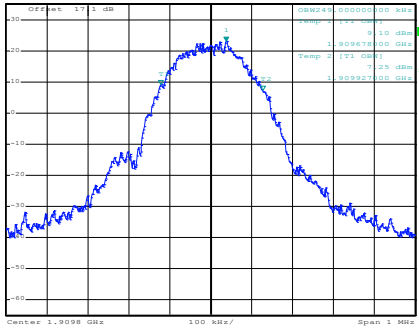

GSM1900 (GPRS class 8)	GSM1900 (EDGE class 8)
<p style="text-align: center;">Lowest Channel</p>  <p style="text-align: right;">Date: 7.JUL.2016 16:21:26</p>	<p style="text-align: center;">Lowest Channel</p>  <p style="text-align: right;">Date: 7.JUL.2016 17:05:11</p>
<p style="text-align: center;">Middle Channel</p>  <p style="text-align: right;">Date: 7.JUL.2016 16:22:15</p>	<p style="text-align: center;">Middle Channel</p>  <p style="text-align: right;">Date: 7.JUL.2016 17:05:42</p>
<p style="text-align: center;">Highest Channel</p>  <p style="text-align: right;">Date: 7.JUL.2016 16:22:48</p>	<p style="text-align: center;">Highest Channel</p>  <p style="text-align: right;">Date: 7.JUL.2016 17:06:42</p>



Conducted Band Edge

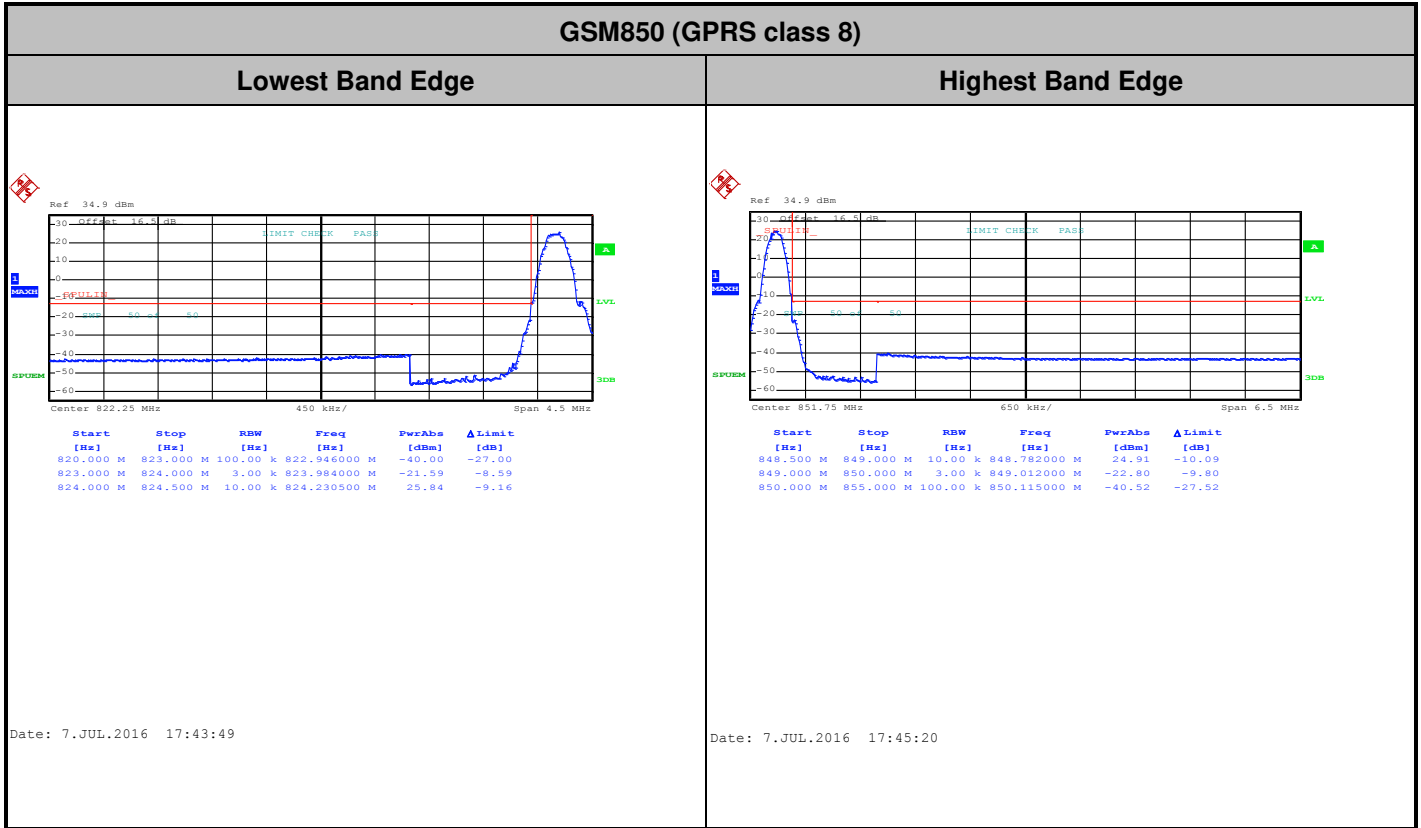



GSM850 (EDGE class 8)

Lowest Band Edge

Highest Band Edge

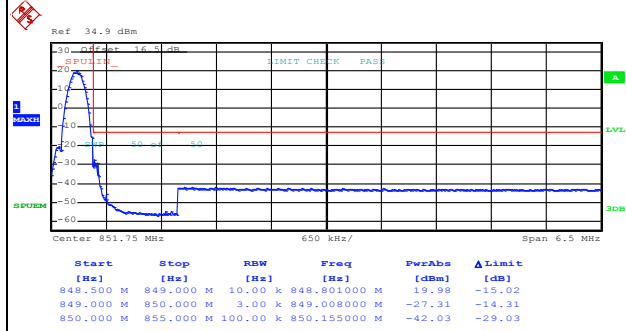
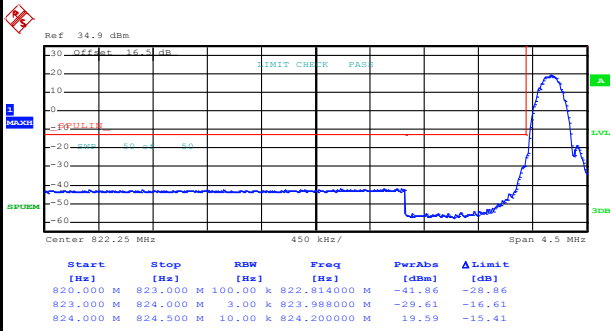

Date: 7.JUL.2016 17:28:49

Date: 7.JUL.2016 17:30:18



GSM1900 (GPRS class 8)

Lowest Band Edge

Highest Band Edge

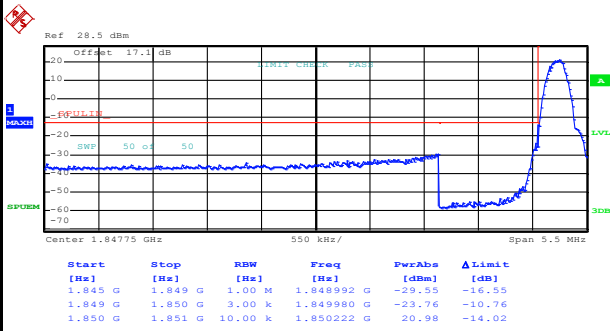

Date: 7.JUL.2016 16:24:51

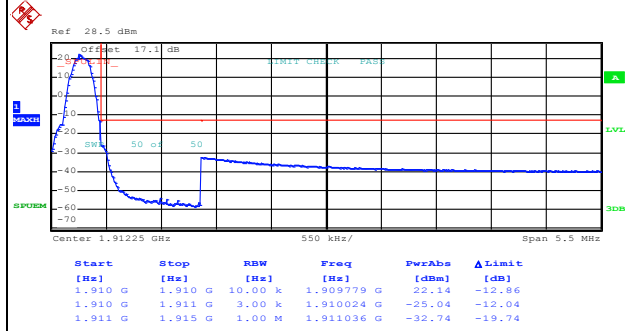

Date: 7.JUL.2016 16:26:21



GSM1900 (EDGE class 8)

Lowest Band Edge

Highest Band Edge

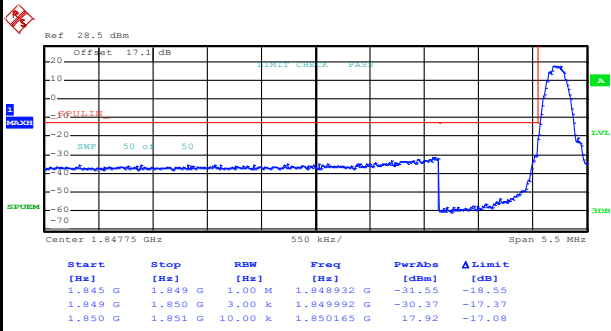

Date: 7.JUL.2016 17:08:18

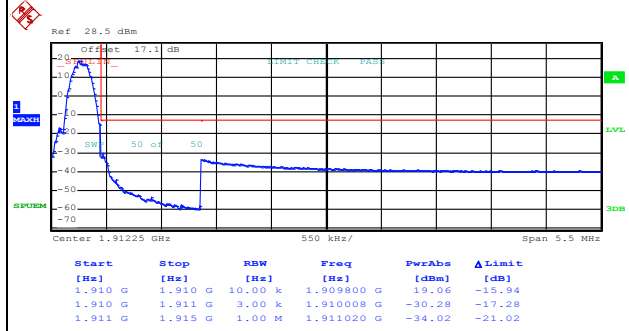

Date: 7.JUL.2016 17:09:46



Conducted Spurious Emission

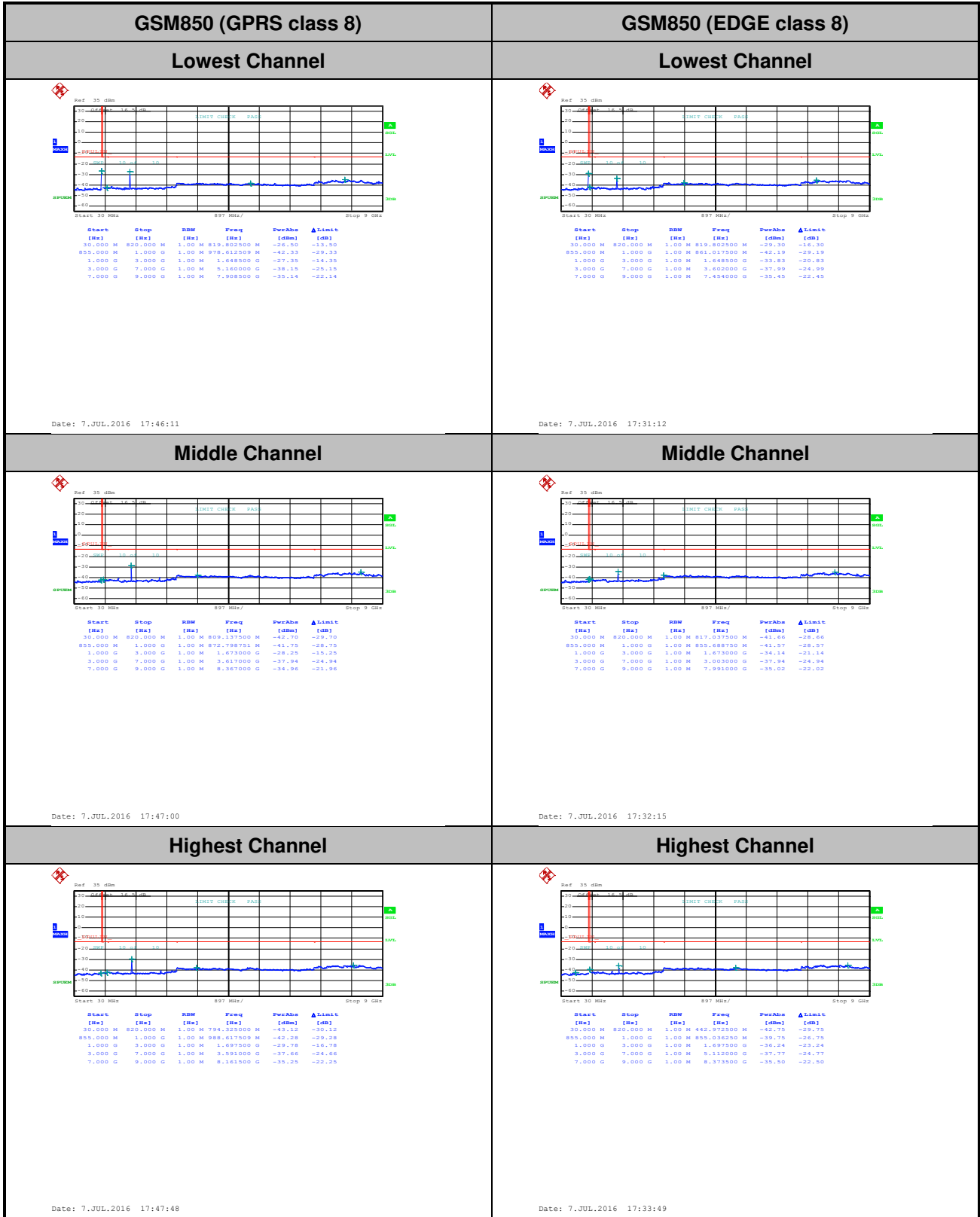

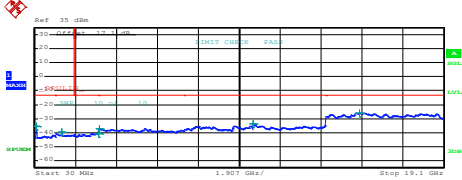
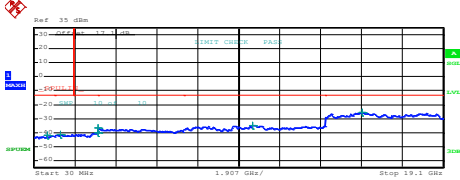
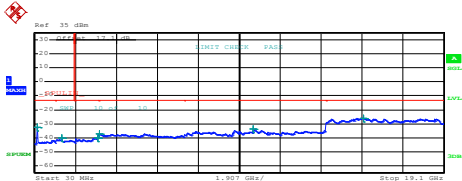
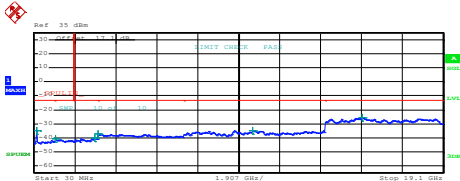
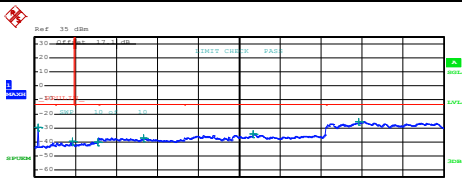
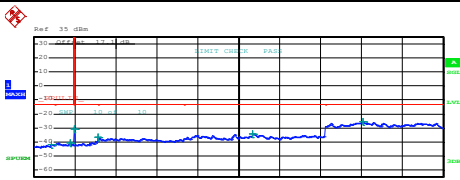

GSM1900 (GPRS class 8)	GSM1900 (EDGE class 8)																																																																																				
Lowest Channel	Lowest Channel																																																																																				
 <table border="1" data-bbox="239 571 638 672"> <thead> <tr> <th>Start [Hz]</th> <th>Stop [Hz]</th> <th>RBW [Hz]</th> <th>Freq [Hz]</th> <th>PwrAve [dBm]</th> <th>ΔLimit [dB]</th> </tr> </thead> <tbody> <tr><td>30.0000 M</td><td>1.0000 G</td><td>1.00 M</td><td>111.965000 M</td><td>-35.53</td><td>-22.73</td></tr> <tr><td>1.0000 G</td><td>1.845 G</td><td>1.00 M</td><td>1.273780 G</td><td>-39.67</td><td>-26.67</td></tr> <tr><td>1.845 G</td><td>3.0000 G</td><td>1.00 M</td><td>2.993490 G</td><td>-40.28</td><td>-27.08</td></tr> <tr><td>3.0000 G</td><td>7.0000 G</td><td>1.00 M</td><td>3.027000 G</td><td>-37.44</td><td>-24.44</td></tr> <tr><td>7.0000 G</td><td>13.6000 G</td><td>1.00 M</td><td>10.225750 G</td><td>-33.73</td><td>-20.73</td></tr> <tr><td>13.6000 G</td><td>19.1000 G</td><td>1.00 M</td><td>15.188812 G</td><td>-25.89</td><td>-12.89</td></tr> </tbody> </table> <p>Date: 7.JUL.2016 16:29:17</p>	Start [Hz]	Stop [Hz]	RBW [Hz]	Freq [Hz]	PwrAve [dBm]	ΔLimit [dB]	30.0000 M	1.0000 G	1.00 M	111.965000 M	-35.53	-22.73	1.0000 G	1.845 G	1.00 M	1.273780 G	-39.67	-26.67	1.845 G	3.0000 G	1.00 M	2.993490 G	-40.28	-27.08	3.0000 G	7.0000 G	1.00 M	3.027000 G	-37.44	-24.44	7.0000 G	13.6000 G	1.00 M	10.225750 G	-33.73	-20.73	13.6000 G	19.1000 G	1.00 M	15.188812 G	-25.89	-12.89	 <table border="1" data-bbox="888 571 1287 672"> <thead> <tr> <th>Start [Hz]</th> <th>Stop [Hz]</th> <th>RBW [Hz]</th> <th>Freq [Hz]</th> <th>PwrAve [dBm]</th> <th>ΔLimit [dB]</th> </tr> </thead> <tbody> <tr><td>30.0000 M</td><td>1.0000 G</td><td>1.00 M</td><td>658.076000 M</td><td>-42.04</td><td>-29.04</td></tr> <tr><td>1.0000 G</td><td>1.845 G</td><td>1.00 M</td><td>1.264485 G</td><td>-41.25</td><td>-28.25</td></tr> <tr><td>1.845 G</td><td>3.0000 G</td><td>1.00 M</td><td>2.993931 G</td><td>-39.97</td><td>-26.97</td></tr> <tr><td>3.0000 G</td><td>7.0000 G</td><td>1.00 M</td><td>3.020000 G</td><td>-36.78</td><td>-23.78</td></tr> <tr><td>7.0000 G</td><td>13.6000 G</td><td>1.00 M</td><td>10.220890 G</td><td>-34.66</td><td>-21.66</td></tr> <tr><td>13.6000 G</td><td>19.1000 G</td><td>1.00 M</td><td>15.320813 G</td><td>-25.72</td><td>-12.72</td></tr> </tbody> </table> <p>Date: 7.JUL.2016 17:10:36</p>	Start [Hz]	Stop [Hz]	RBW [Hz]	Freq [Hz]	PwrAve [dBm]	ΔLimit [dB]	30.0000 M	1.0000 G	1.00 M	658.076000 M	-42.04	-29.04	1.0000 G	1.845 G	1.00 M	1.264485 G	-41.25	-28.25	1.845 G	3.0000 G	1.00 M	2.993931 G	-39.97	-26.97	3.0000 G	7.0000 G	1.00 M	3.020000 G	-36.78	-23.78	7.0000 G	13.6000 G	1.00 M	10.220890 G	-34.66	-21.66	13.6000 G	19.1000 G	1.00 M	15.320813 G	-25.72	-12.72
Start [Hz]	Stop [Hz]	RBW [Hz]	Freq [Hz]	PwrAve [dBm]	ΔLimit [dB]																																																																																
30.0000 M	1.0000 G	1.00 M	111.965000 M	-35.53	-22.73																																																																																
1.0000 G	1.845 G	1.00 M	1.273780 G	-39.67	-26.67																																																																																
1.845 G	3.0000 G	1.00 M	2.993490 G	-40.28	-27.08																																																																																
3.0000 G	7.0000 G	1.00 M	3.027000 G	-37.44	-24.44																																																																																
7.0000 G	13.6000 G	1.00 M	10.225750 G	-33.73	-20.73																																																																																
13.6000 G	19.1000 G	1.00 M	15.188812 G	-25.89	-12.89																																																																																
Start [Hz]	Stop [Hz]	RBW [Hz]	Freq [Hz]	PwrAve [dBm]	ΔLimit [dB]																																																																																
30.0000 M	1.0000 G	1.00 M	658.076000 M	-42.04	-29.04																																																																																
1.0000 G	1.845 G	1.00 M	1.264485 G	-41.25	-28.25																																																																																
1.845 G	3.0000 G	1.00 M	2.993931 G	-39.97	-26.97																																																																																
3.0000 G	7.0000 G	1.00 M	3.020000 G	-36.78	-23.78																																																																																
7.0000 G	13.6000 G	1.00 M	10.220890 G	-34.66	-21.66																																																																																
13.6000 G	19.1000 G	1.00 M	15.320813 G	-25.72	-12.72																																																																																
Middle Channel	Middle Channel																																																																																				
 <table border="1" data-bbox="239 1086 638 1187"> <thead> <tr> <th>Start [Hz]</th> <th>Stop [Hz]</th> <th>RBW [Hz]</th> <th>Freq [Hz]</th> <th>PwrAve [dBm]</th> <th>ΔLimit [dB]</th> </tr> </thead> <tbody> <tr><td>30.0000 M</td><td>1.0000 G</td><td>1.00 M</td><td>141.792500 M</td><td>-32.40</td><td>-19.40</td></tr> <tr><td>1.0000 G</td><td>1.845 G</td><td>1.00 M</td><td>1.276836 G</td><td>-40.22</td><td>-27.22</td></tr> <tr><td>1.845 G</td><td>3.0000 G</td><td>1.00 M</td><td>2.973689 G</td><td>-40.24</td><td>-27.24</td></tr> <tr><td>3.0000 G</td><td>7.0000 G</td><td>1.00 M</td><td>3.038000 G</td><td>-37.08</td><td>-24.08</td></tr> <tr><td>7.0000 G</td><td>13.6000 G</td><td>1.00 M</td><td>10.231325 G</td><td>-33.96</td><td>-20.96</td></tr> <tr><td>13.6000 G</td><td>19.1000 G</td><td>1.00 M</td><td>15.364125 G</td><td>-26.05</td><td>-13.05</td></tr> </tbody> </table> <p>Date: 7.JUL.2016 16:30:07</p>	Start [Hz]	Stop [Hz]	RBW [Hz]	Freq [Hz]	PwrAve [dBm]	ΔLimit [dB]	30.0000 M	1.0000 G	1.00 M	141.792500 M	-32.40	-19.40	1.0000 G	1.845 G	1.00 M	1.276836 G	-40.22	-27.22	1.845 G	3.0000 G	1.00 M	2.973689 G	-40.24	-27.24	3.0000 G	7.0000 G	1.00 M	3.038000 G	-37.08	-24.08	7.0000 G	13.6000 G	1.00 M	10.231325 G	-33.96	-20.96	13.6000 G	19.1000 G	1.00 M	15.364125 G	-26.05	-13.05	 <table border="1" data-bbox="888 1086 1287 1187"> <thead> <tr> <th>Start [Hz]</th> <th>Stop [Hz]</th> <th>RBW [Hz]</th> <th>Freq [Hz]</th> <th>PwrAve [dBm]</th> <th>ΔLimit [dB]</th> </tr> </thead> <tbody> <tr><td>30.0000 M</td><td>1.0000 G</td><td>1.00 M</td><td>141.550000 M</td><td>-35.04</td><td>-22.04</td></tr> <tr><td>1.0000 G</td><td>1.845 G</td><td>1.00 M</td><td>1.269808 G</td><td>-40.36</td><td>-27.36</td></tr> <tr><td>1.845 G</td><td>3.0000 G</td><td>1.00 M</td><td>2.854339 G</td><td>-40.30</td><td>-27.30</td></tr> <tr><td>3.0000 G</td><td>7.0000 G</td><td>1.00 M</td><td>3.008000 G</td><td>-37.34</td><td>-24.34</td></tr> <tr><td>7.0000 G</td><td>13.6000 G</td><td>1.00 M</td><td>10.232950 G</td><td>-34.62</td><td>-21.62</td></tr> <tr><td>13.6000 G</td><td>19.1000 G</td><td>1.00 M</td><td>15.332500 G</td><td>-25.64</td><td>-12.64</td></tr> </tbody> </table> <p>Date: 7.JUL.2016 17:11:46</p>	Start [Hz]	Stop [Hz]	RBW [Hz]	Freq [Hz]	PwrAve [dBm]	ΔLimit [dB]	30.0000 M	1.0000 G	1.00 M	141.550000 M	-35.04	-22.04	1.0000 G	1.845 G	1.00 M	1.269808 G	-40.36	-27.36	1.845 G	3.0000 G	1.00 M	2.854339 G	-40.30	-27.30	3.0000 G	7.0000 G	1.00 M	3.008000 G	-37.34	-24.34	7.0000 G	13.6000 G	1.00 M	10.232950 G	-34.62	-21.62	13.6000 G	19.1000 G	1.00 M	15.332500 G	-25.64	-12.64
Start [Hz]	Stop [Hz]	RBW [Hz]	Freq [Hz]	PwrAve [dBm]	ΔLimit [dB]																																																																																
30.0000 M	1.0000 G	1.00 M	141.792500 M	-32.40	-19.40																																																																																
1.0000 G	1.845 G	1.00 M	1.276836 G	-40.22	-27.22																																																																																
1.845 G	3.0000 G	1.00 M	2.973689 G	-40.24	-27.24																																																																																
3.0000 G	7.0000 G	1.00 M	3.038000 G	-37.08	-24.08																																																																																
7.0000 G	13.6000 G	1.00 M	10.231325 G	-33.96	-20.96																																																																																
13.6000 G	19.1000 G	1.00 M	15.364125 G	-26.05	-13.05																																																																																
Start [Hz]	Stop [Hz]	RBW [Hz]	Freq [Hz]	PwrAve [dBm]	ΔLimit [dB]																																																																																
30.0000 M	1.0000 G	1.00 M	141.550000 M	-35.04	-22.04																																																																																
1.0000 G	1.845 G	1.00 M	1.269808 G	-40.36	-27.36																																																																																
1.845 G	3.0000 G	1.00 M	2.854339 G	-40.30	-27.30																																																																																
3.0000 G	7.0000 G	1.00 M	3.008000 G	-37.34	-24.34																																																																																
7.0000 G	13.6000 G	1.00 M	10.232950 G	-34.62	-21.62																																																																																
13.6000 G	19.1000 G	1.00 M	15.332500 G	-25.64	-12.64																																																																																
Highest Channel	Highest Channel																																																																																				
 <table border="1" data-bbox="239 1601 638 1702"> <thead> <tr> <th>Start [Hz]</th> <th>Stop [Hz]</th> <th>RBW [Hz]</th> <th>Freq [Hz]</th> <th>PwrAve [dBm]</th> <th>ΔLimit [dB]</th> </tr> </thead> <tbody> <tr><td>30.0000 M</td><td>1.0000 G</td><td>1.00 M</td><td>171.620000 M</td><td>-32.65</td><td>-19.65</td></tr> <tr><td>1.0000 G</td><td>1.845 G</td><td>1.00 M</td><td>1.794723 G</td><td>-39.68</td><td>-26.68</td></tr> <tr><td>1.845 G</td><td>3.0000 G</td><td>1.00 M</td><td>2.933074 G</td><td>-40.14</td><td>-27.14</td></tr> <tr><td>3.0000 G</td><td>7.0000 G</td><td>1.00 M</td><td>3.115000 G</td><td>-37.07</td><td>-24.07</td></tr> <tr><td>7.0000 G</td><td>13.6000 G</td><td>1.00 M</td><td>10.212350 G</td><td>-34.48</td><td>-21.48</td></tr> <tr><td>13.6000 G</td><td>19.1000 G</td><td>1.00 M</td><td>15.133750 G</td><td>-25.59</td><td>-12.59</td></tr> </tbody> </table> <p>Date: 7.JUL.2016 16:30:54</p>	Start [Hz]	Stop [Hz]	RBW [Hz]	Freq [Hz]	PwrAve [dBm]	ΔLimit [dB]	30.0000 M	1.0000 G	1.00 M	171.620000 M	-32.65	-19.65	1.0000 G	1.845 G	1.00 M	1.794723 G	-39.68	-26.68	1.845 G	3.0000 G	1.00 M	2.933074 G	-40.14	-27.14	3.0000 G	7.0000 G	1.00 M	3.115000 G	-37.07	-24.07	7.0000 G	13.6000 G	1.00 M	10.212350 G	-34.48	-21.48	13.6000 G	19.1000 G	1.00 M	15.133750 G	-25.59	-12.59	 <table border="1" data-bbox="888 1601 1287 1702"> <thead> <tr> <th>Start [Hz]</th> <th>Stop [Hz]</th> <th>RBW [Hz]</th> <th>Freq [Hz]</th> <th>PwrAve [dBm]</th> <th>ΔLimit [dB]</th> </tr> </thead> <tbody> <tr><td>30.0000 M</td><td>1.0000 G</td><td>1.00 M</td><td>837.040000 M</td><td>-41.75</td><td>-28.75</td></tr> <tr><td>1.0000 G</td><td>1.845 G</td><td>1.00 M</td><td>1.718250 G</td><td>-40.62</td><td>-27.62</td></tr> <tr><td>1.845 G</td><td>3.0000 G</td><td>1.00 M</td><td>1.933271 G</td><td>-39.73</td><td>-26.73</td></tr> <tr><td>3.0000 G</td><td>7.0000 G</td><td>1.00 M</td><td>3.008000 G</td><td>-36.92</td><td>-23.92</td></tr> <tr><td>7.0000 G</td><td>13.6000 G</td><td>1.00 M</td><td>10.207600 G</td><td>-34.47</td><td>-21.47</td></tr> <tr><td>13.6000 G</td><td>19.1000 G</td><td>1.00 M</td><td>15.305500 G</td><td>-25.69</td><td>-12.69</td></tr> </tbody> </table> <p>Date: 7.JUL.2016 17:12:37</p>	Start [Hz]	Stop [Hz]	RBW [Hz]	Freq [Hz]	PwrAve [dBm]	ΔLimit [dB]	30.0000 M	1.0000 G	1.00 M	837.040000 M	-41.75	-28.75	1.0000 G	1.845 G	1.00 M	1.718250 G	-40.62	-27.62	1.845 G	3.0000 G	1.00 M	1.933271 G	-39.73	-26.73	3.0000 G	7.0000 G	1.00 M	3.008000 G	-36.92	-23.92	7.0000 G	13.6000 G	1.00 M	10.207600 G	-34.47	-21.47	13.6000 G	19.1000 G	1.00 M	15.305500 G	-25.69	-12.69
Start [Hz]	Stop [Hz]	RBW [Hz]	Freq [Hz]	PwrAve [dBm]	ΔLimit [dB]																																																																																
30.0000 M	1.0000 G	1.00 M	171.620000 M	-32.65	-19.65																																																																																
1.0000 G	1.845 G	1.00 M	1.794723 G	-39.68	-26.68																																																																																
1.845 G	3.0000 G	1.00 M	2.933074 G	-40.14	-27.14																																																																																
3.0000 G	7.0000 G	1.00 M	3.115000 G	-37.07	-24.07																																																																																
7.0000 G	13.6000 G	1.00 M	10.212350 G	-34.48	-21.48																																																																																
13.6000 G	19.1000 G	1.00 M	15.133750 G	-25.59	-12.59																																																																																
Start [Hz]	Stop [Hz]	RBW [Hz]	Freq [Hz]	PwrAve [dBm]	ΔLimit [dB]																																																																																
30.0000 M	1.0000 G	1.00 M	837.040000 M	-41.75	-28.75																																																																																
1.0000 G	1.845 G	1.00 M	1.718250 G	-40.62	-27.62																																																																																
1.845 G	3.0000 G	1.00 M	1.933271 G	-39.73	-26.73																																																																																
3.0000 G	7.0000 G	1.00 M	3.008000 G	-36.92	-23.92																																																																																
7.0000 G	13.6000 G	1.00 M	10.207600 G	-34.47	-21.47																																																																																
13.6000 G	19.1000 G	1.00 M	15.305500 G	-25.69	-12.69																																																																																



Frequency Stability

Test Conditions	Middle Channel	GSM850 (GSM)	GSM850 (EDGE class 8)	Limit 2.5ppm
Temperature (°C)	Voltage (Volt)	Deviation (ppm)		Result
50	Normal Voltage	0.0048	0.0167	PASS
40	Normal Voltage	0.0024	0.0155	
30	Normal Voltage	0.0036	0.0072	
20(Ref.)	Normal Voltage	0.0000	0.0000	
10	Normal Voltage	0.0036	0.0048	
0	Normal Voltage	0.0108	0.0012	
-10	Normal Voltage	0.0084	0.0048	
-20	Normal Voltage	0.0155	0.0096	
-30	Normal Voltage	0.0191	0.0072	
20	Maximum Voltage	0.0024	0.0012	
20	Normal Voltage	0.0048	0.0024	
20	Battery End Point	0.0000	0.0072	

Note:

- 1. Normal Voltage = 3.3V. ; Battery End Point (BEP) = 3.0 V. ; Maximum Voltage =3.6 V
- 2. The frequency fundamental emissions stay within the authorized frequency block.



Test Conditions	Middle Channel	GSM1900 (GSM)	GSM1900 (EDGE class 8)	Limit Note 2.
Temperature (°C)	Voltage (Volt)	Deviation (ppm)		Result
50	Normal Voltage	0.0043	0.0048	PASS
40	Normal Voltage	0.0053	0.0032	
30	Normal Voltage	0.0032	0.0016	
20(Ref.)	Normal Voltage	0.0000	0.0000	
10	Normal Voltage	0.0048	0.0005	
0	Normal Voltage	0.0069	0.0011	
-10	Normal Voltage	0.0053	0.0021	
-20	Normal Voltage	0.0032	0.0059	
-30	Normal Voltage	0.0090	0.0027	
20	Maximum Voltage	0.0053	0.0064	
20	Normal Voltage	0.0048	0.0027	
20	Battery End Point	0.0064	0.0005	

Note:

- 1. Normal Voltage = 3.3V. ; Battery End Point (BEP) = 3.0 V. ; Maximum Voltage =3.6 V
- 2. The frequency fundamental emissions stay within the authorized frequency block.



A2. WCDMA

Peak-to-Average Ratio

Mode	WCDMA Band V	WCDMA Band II	WCDMA Band IV	Limit: 13dB
Mod.	RMC 12.2Kbps	RMC 12.2Kbps	RMC 12.2Kbps	Result
Lowest CH	3.24	3.00	3.08	PASS
Middle CH	3.28	2.96	2.80	
Highest CH	3.32	2.96	2.84	

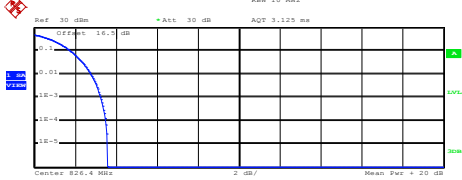
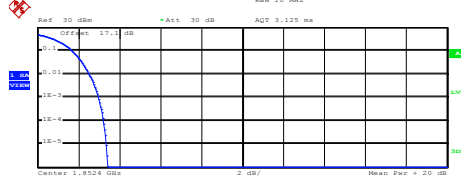
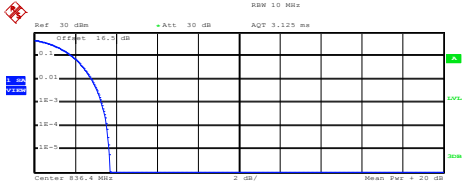
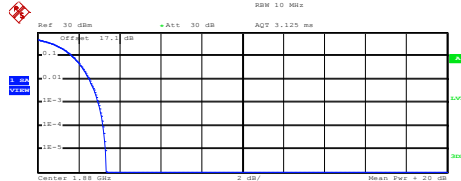
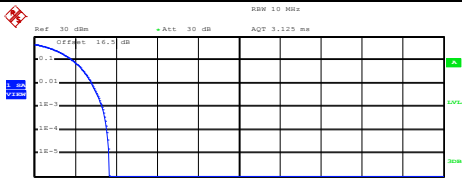
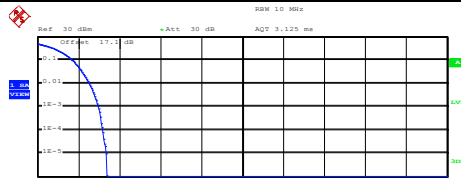

WCDMA Band V (RMC 12.2Kbps)	WCDMA Band II (RMC 12.2Kbps)																
<p style="text-align: center;">Lowest Channel</p>  <p>Center 826.4 MHz 2 dB/ Mean Pwr + 20 dB</p> <p>Complementary Cumulative Distribution Function (100000 samples) Trace 1 Mean 22.50 dBm Peak 26.09 dBm Crest 3.59 dB</p> <table border="1"> <tr><td>10 %</td><td>1.76 dB</td></tr> <tr><td>1 %</td><td>2.76 dB</td></tr> <tr><td>.1 %</td><td>3.24 dB</td></tr> <tr><td>.01 %</td><td>3.52 dB</td></tr> </table> <p>Date: 7.JUL.2016 18:09:52</p>	10 %	1.76 dB	1 %	2.76 dB	.1 %	3.24 dB	.01 %	3.52 dB	<p style="text-align: center;">Lowest Channel</p>  <p>Center 1.8524 GHz 2 dB/ Mean Pwr + 20 dB</p> <p>Complementary Cumulative Distribution Function (100000 samples) Trace 1 Mean 21.26 dBm Peak 24.68 dBm Crest 3.42 dB</p> <table border="1"> <tr><td>10 %</td><td>1.68 dB</td></tr> <tr><td>1 %</td><td>2.52 dB</td></tr> <tr><td>.1 %</td><td>3.00 dB</td></tr> <tr><td>.01 %</td><td>3.24 dB</td></tr> </table> <p>Date: 7.JUL.2016 18:25:31</p>	10 %	1.68 dB	1 %	2.52 dB	.1 %	3.00 dB	.01 %	3.24 dB
10 %	1.76 dB																
1 %	2.76 dB																
.1 %	3.24 dB																
.01 %	3.52 dB																
10 %	1.68 dB																
1 %	2.52 dB																
.1 %	3.00 dB																
.01 %	3.24 dB																
<p style="text-align: center;">Middle Channel</p>  <p>Center 830.4 MHz 2 dB/ Mean Pwr + 20 dB</p> <p>Complementary Cumulative Distribution Function (100000 samples) Trace 1 Mean 21.88 dBm Peak 25.60 dBm Crest 3.72 dB</p> <table border="1"> <tr><td>10 %</td><td>1.84 dB</td></tr> <tr><td>1 %</td><td>2.80 dB</td></tr> <tr><td>.1 %</td><td>3.28 dB</td></tr> <tr><td>.01 %</td><td>3.56 dB</td></tr> </table> <p>Date: 7.JUL.2016 18:10:28</p>	10 %	1.84 dB	1 %	2.80 dB	.1 %	3.28 dB	.01 %	3.56 dB	<p style="text-align: center;">Middle Channel</p>  <p>Center 1.88 GHz 2 dB/ Mean Pwr + 20 dB</p> <p>Complementary Cumulative Distribution Function (100000 samples) Trace 1 Mean 21.76 dBm Peak 25.10 dBm Crest 3.35 dB</p> <table border="1"> <tr><td>10 %</td><td>1.68 dB</td></tr> <tr><td>1 %</td><td>2.52 dB</td></tr> <tr><td>.1 %</td><td>2.96 dB</td></tr> <tr><td>.01 %</td><td>3.20 dB</td></tr> </table> <p>Date: 7.JUL.2016 18:25:47</p>	10 %	1.68 dB	1 %	2.52 dB	.1 %	2.96 dB	.01 %	3.20 dB
10 %	1.84 dB																
1 %	2.80 dB																
.1 %	3.28 dB																
.01 %	3.56 dB																
10 %	1.68 dB																
1 %	2.52 dB																
.1 %	2.96 dB																
.01 %	3.20 dB																
<p style="text-align: center;">Highest Channel</p>  <p>Center 846.6 MHz 2 dB/ Mean Pwr + 20 dB</p> <p>Complementary Cumulative Distribution Function (100000 samples) Trace 1 Mean 21.71 dBm Peak 25.38 dBm Crest 3.67 dB</p> <table border="1"> <tr><td>10 %</td><td>1.88 dB</td></tr> <tr><td>1 %</td><td>2.80 dB</td></tr> <tr><td>.1 %</td><td>3.32 dB</td></tr> <tr><td>.01 %</td><td>3.56 dB</td></tr> </table> <p>Date: 7.JUL.2016 18:10:42</p>	10 %	1.88 dB	1 %	2.80 dB	.1 %	3.32 dB	.01 %	3.56 dB	<p style="text-align: center;">Highest Channel</p>  <p>Center 1.9076 GHz 2 dB/ Mean Pwr + 20 dB</p> <p>Complementary Cumulative Distribution Function (100000 samples) Trace 1 Mean 22.14 dBm Peak 25.53 dBm Crest 3.39 dB</p> <table border="1"> <tr><td>10 %</td><td>1.72 dB</td></tr> <tr><td>1 %</td><td>2.52 dB</td></tr> <tr><td>.1 %</td><td>2.96 dB</td></tr> <tr><td>.01 %</td><td>3.20 dB</td></tr> </table> <p>Date: 7.JUL.2016 18:26:14</p>	10 %	1.72 dB	1 %	2.52 dB	.1 %	2.96 dB	.01 %	3.20 dB
10 %	1.88 dB																
1 %	2.80 dB																
.1 %	3.32 dB																
.01 %	3.56 dB																
10 %	1.72 dB																
1 %	2.52 dB																
.1 %	2.96 dB																
.01 %	3.20 dB																



WCDMA Band IV (RMC 12.2Kbps)

Lowest Channel

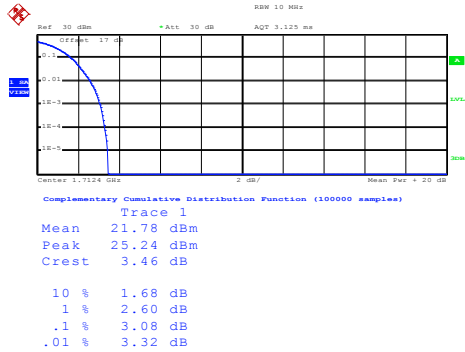

Date: 7.JUL.2016 19:19:31

Middle Channel

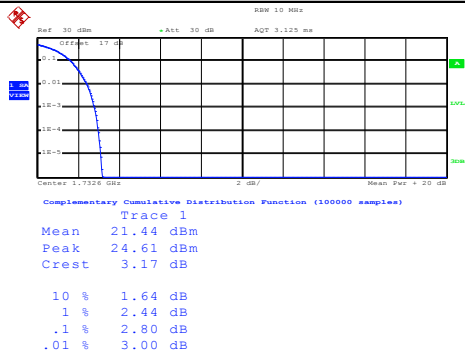

Date: 7.JUL.2016 19:19:43

Highest Channel

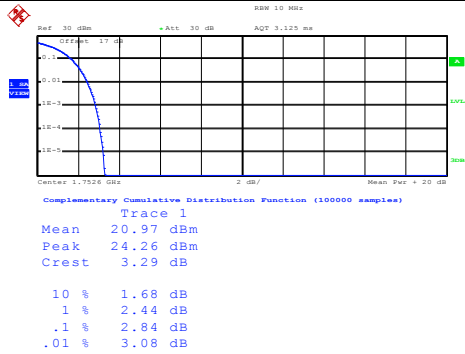

Date: 7.JUL.2016 19:19:52



26dB Bandwidth

Mode	WCDMA Band V	WCDMA Band II	WCDMA Band IV
Mod.	RMC 12.2Kbps	RMC 12.2Kbps	RMC 12.2Kbps
Lowest CH	4.69	4.72	4.72
Middle CH	4.72	4.75	4.73
Highest CH	4.72	4.73	4.71

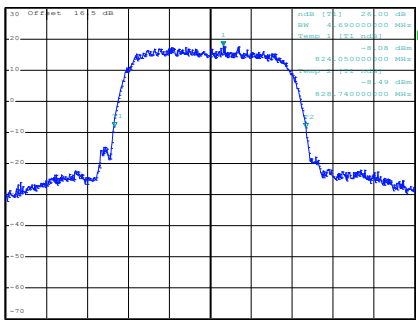
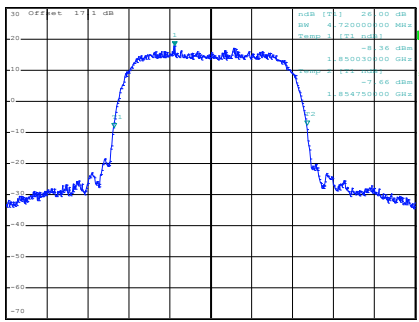
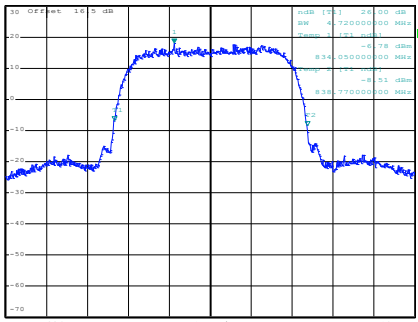
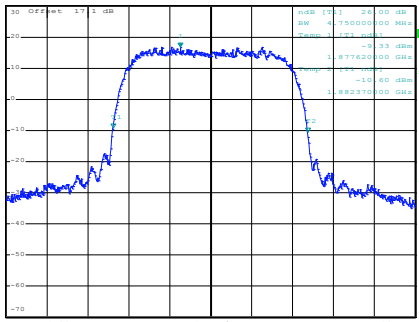
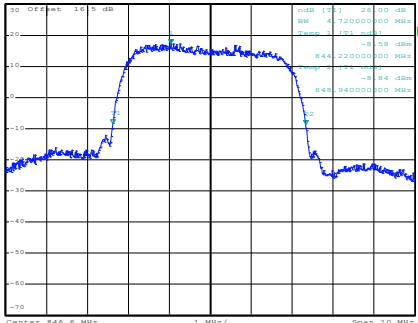
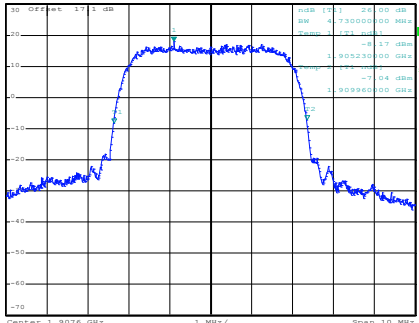

WCDMA Band V (RMC 12.2Kbps)	WCDMA Band II (RMC 12.2Kbps)
<p style="text-align: center;">Lowest Channel</p>  <p>Date: 7.JUL.2016 17:51:50</p>	<p style="text-align: center;">Lowest Channel</p>  <p>Date: 7.JUL.2016 18:11:38</p>
<p style="text-align: center;">Middle Channel</p>  <p>Date: 7.JUL.2016 17:52:18</p>	<p style="text-align: center;">Middle Channel</p>  <p>Date: 7.JUL.2016 18:12:06</p>
<p style="text-align: center;">Highest Channel</p>  <p>Date: 7.JUL.2016 17:52:46</p>	<p style="text-align: center;">Highest Channel</p>  <p>Date: 7.JUL.2016 18:12:34</p>



WCDMA Band IV (RMC 12.2Kbps)

Lowest Channel

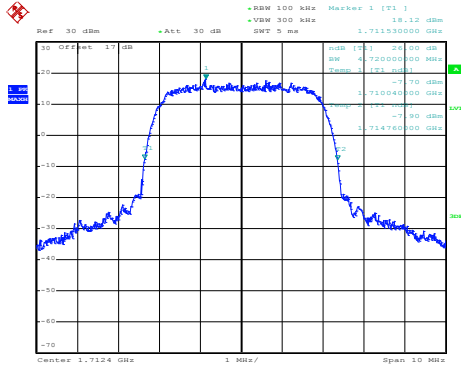

Date: 7.JUL.2016 19:03:11

Middle Channel

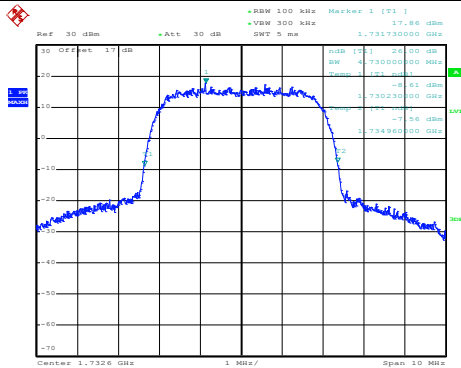

Date: 7.JUL.2016 19:03:39

Highest Channel

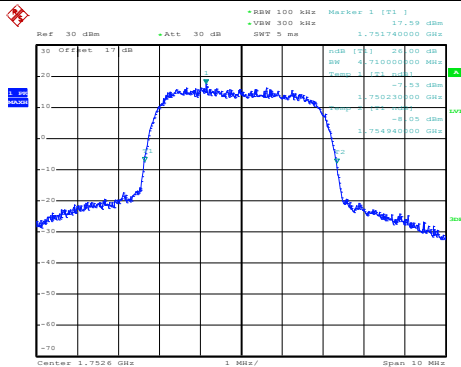

Date: 7.JUL.2016 19:04:07



Occupied Bandwidth

Mode	WCDMA Band V	WCDMA Band II	WCDMA Band IV
Mod.	RMC 12.2Kbps	RMC 12.2Kbps	RMC 12.2Kbps
Lowest CH	4.12	4.16	4.13
Middle CH	4.15	4.15	4.14
Highest CH	4.14	4.14	4.15

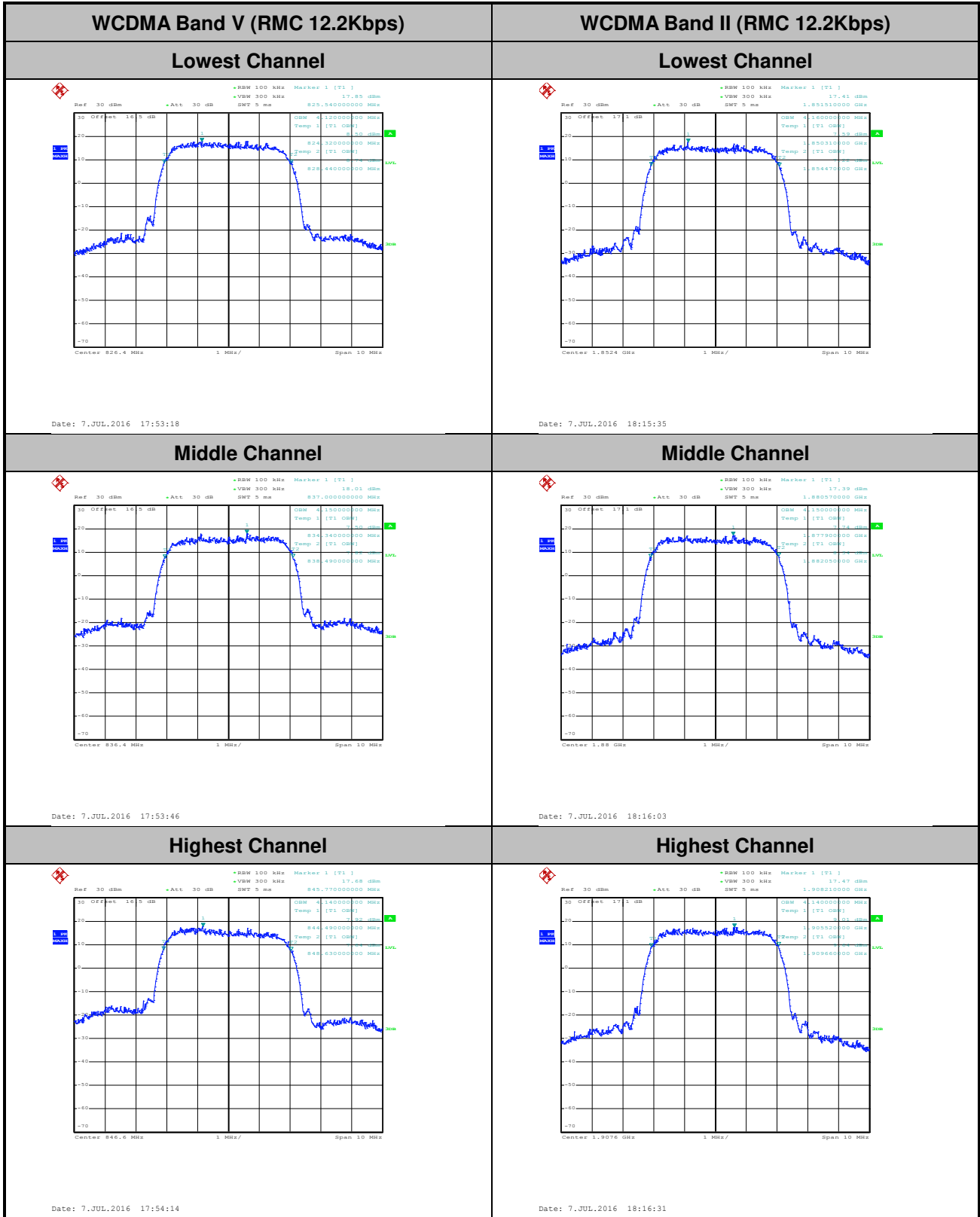



WCDMA Band IV (RMC 12.2Kbps)

Lowest Channel

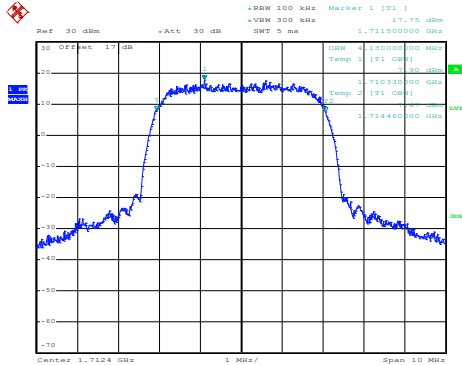

Date: 7.JUL.2016 19:06:16

Middle Channel

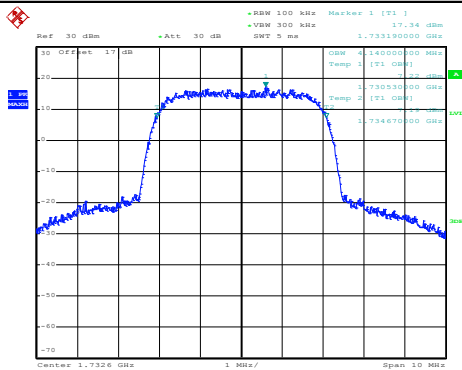

Date: 7.JUL.2016 19:06:44

Highest Channel

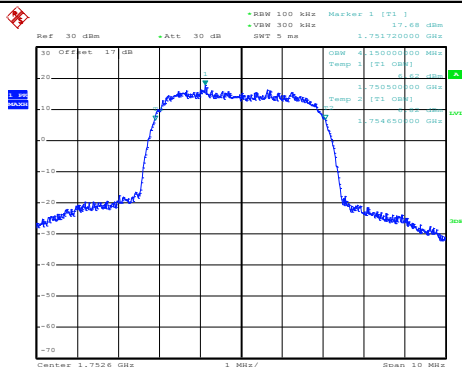

Date: 7.JUL.2016 19:07:12



Conducted Band Edge



WCDMA Band V (RMC 12.2Kbps)

Lowest Band Edge

Highest Band Edge

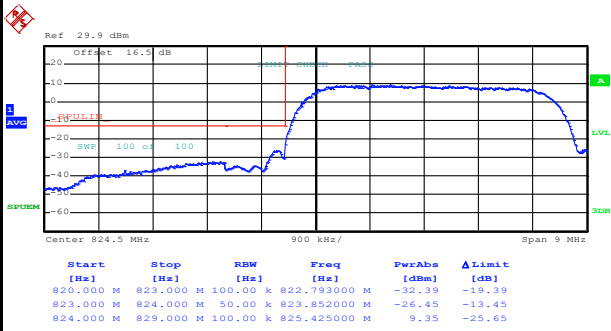

Date: 7.JUL.2016 17:57:03

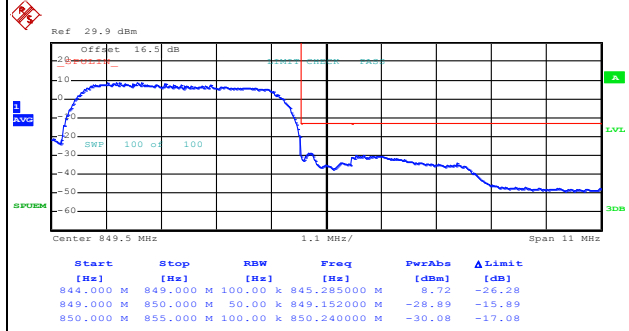

Date: 7.JUL.2016 17:59:46



WCDMA Band II (RMC 12.2Kbps)

Lowest Band Edge

Highest Band Edge

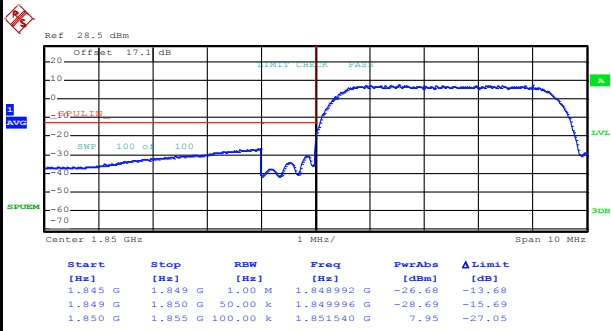

Date: 7.JUL.2016 18:19:40

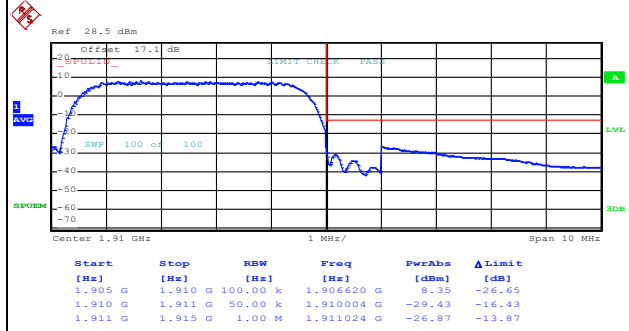

Date: 7.JUL.2016 18:22:24



WCDMA Band IV (RMC 12.2Kbps)

Lowest Band Edge

Highest Band Edge

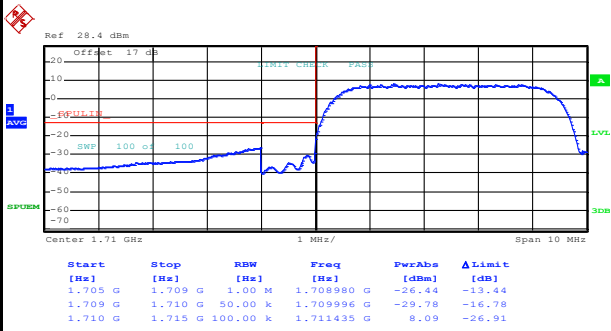

Date: 7.JUL.2016 19:10:14

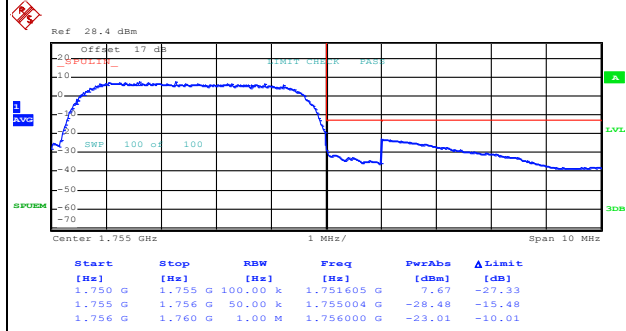

Date: 7.JUL.2016 19:12:57



Conducted Spurious Emission



WCDMA Band V (RMC 12.2Kbps)

WCDMA Band II (RMC 12.2Kbps)

Lowest Channel

Lowest Channel

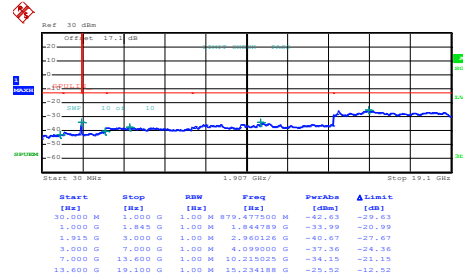
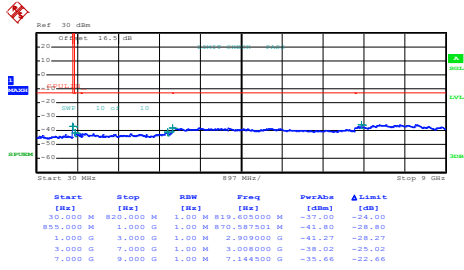

Date: 7.JUL.2016 18:01:01

Date: 7.JUL.2016 18:27:10

Middle Channel

Middle Channel

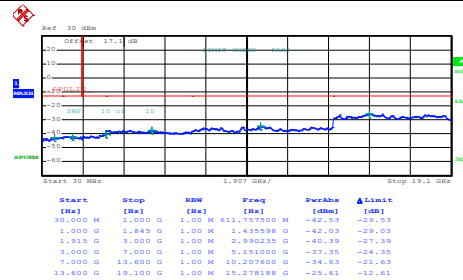
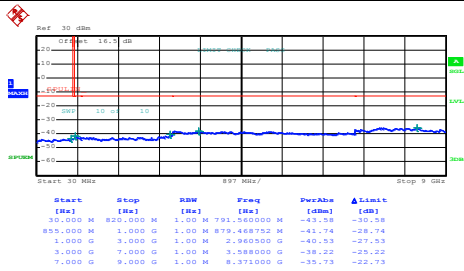

Date: 7.JUL.2016 18:01:46

Date: 7.JUL.2016 18:27:56

Highest Channel

Highest Channel

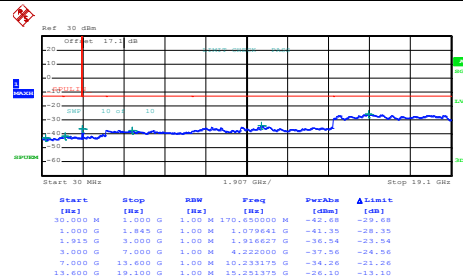
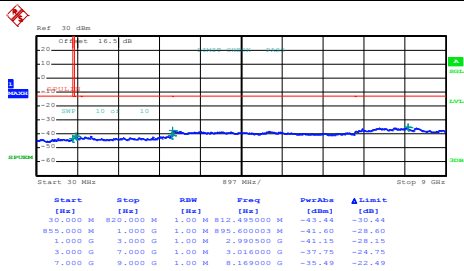

Date: 7.JUL.2016 18:02:32

Date: 7.JUL.2016 18:28:42



WCDMA Band IV (RMC 12.2Kbps)

Lowest Channel

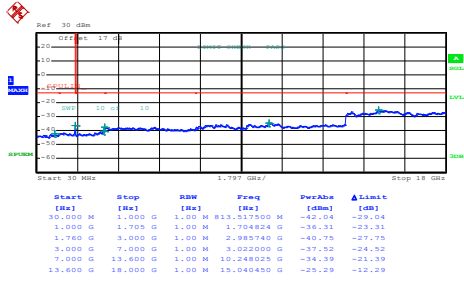

Date: 7.JUL.2016 19:16:57

Middle Channel

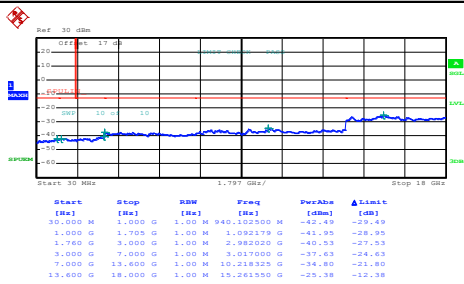

Date: 7.JUL.2016 19:17:44

Highest Channel

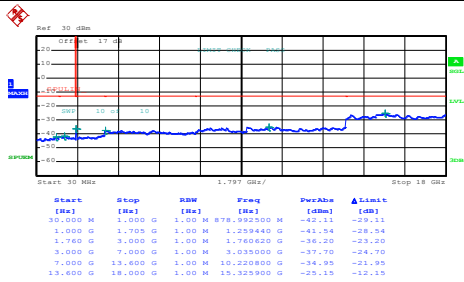

Date: 7.JUL.2016 19:18:30



Frequency Stability

Test Conditions	Middle Channel	WCDMA Band V (RMC 12.2Kbps)	Limit 2.5ppm
Temperature (°C)	Voltage (Volt)	Deviation (ppm)	Result
50	Normal Voltage	0.0072	PASS
40	Normal Voltage	0.0084	
30	Normal Voltage	0.0096	
20(Ref.)	Normal Voltage	0.0000	
10	Normal Voltage	0.0012	
0	Normal Voltage	0.0143	
-10	Normal Voltage	0.0167	
-20	Normal Voltage	0.0155	
-30	Normal Voltage	0.0167	
20	Maximum Voltage	0.0096	
20	Normal Voltage	0.0024	
20	Battery End Point	0.0000	

Note:

- 1. Normal Voltage = 3.3V. ; Battery End Point (BEP) = 3.0 V. ; Maximum Voltage =3.6 V
- 2. The frequency fundamental emissions stay within the authorized frequency block.



Test Conditions	Middle Channel	WCDMA Band II (RMC 12.2Kbps)	Limit Note 2.
Temperature (°C)	Voltage (Volt)	Deviation (ppm)	Result
50	Normal Voltage	0.0011	PASS
40	Normal Voltage	0.0011	
30	Normal Voltage	0.0037	
20(Ref.)	Normal Voltage	0.0000	
10	Normal Voltage	0.0016	
0	Normal Voltage	0.0027	
-10	Normal Voltage	0.0043	
-20	Normal Voltage	0.0037	
-30	Normal Voltage	0.0059	
20	Maximum Voltage	0.0032	
20	Normal Voltage	0.0037	
20	Battery End Point	0.0043	

Note:

1. Normal Voltage = 3.3V. ; Battery End Point (BEP) = 3.0 V. ; Maximum Voltage =3.6 V
2. The frequency fundamental emissions stay within the authorized frequency block.



Test Conditions	Middle Channel	WCDMA Band IV (RMC 12.2Kbps)	Limit Note 2.
Temperature (°C)	Voltage (Volt)	Deviation (ppm)	Result
50	Normal Voltage	0.0006	PASS
40	Normal Voltage	0.0006	
30	Normal Voltage	0.0006	
20(Ref.)	Normal Voltage	0.0000	
10	Normal Voltage	0.0006	
0	Normal Voltage	0.0012	
-10	Normal Voltage	0.0006	
-20	Normal Voltage	0.0052	
-30	Normal Voltage	0.0040	
20	Maximum Voltage	0.0035	
20	Normal Voltage	0.0017	
20	Battery End Point	0.0046	

Note:

1. Normal Voltage = 3.3V. ; Battery End Point (BEP) = 3.0 V. ; Maximum Voltage =3.6 V
2. The frequency fundamental emissions stay within the authorized frequency block.



A3. CDMA

Peak-to-Average Ratio

Mode	CDMA BC0	Limit: 13dB
Mod.	1xRTT	Result
Lowest CH	3.20	PASS
Middle CH	3.80	
Highest CH	3.20	



CDMA BC0 (1xRTT)

Lowest Channel

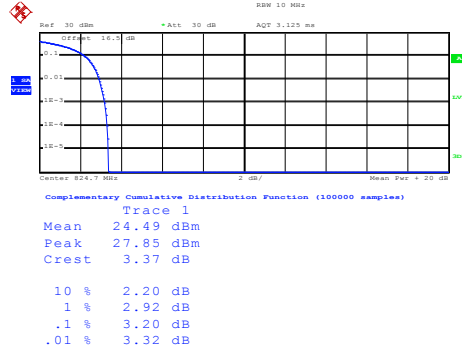

Date: 7.JUL.2016 20:37:17

Middle Channel

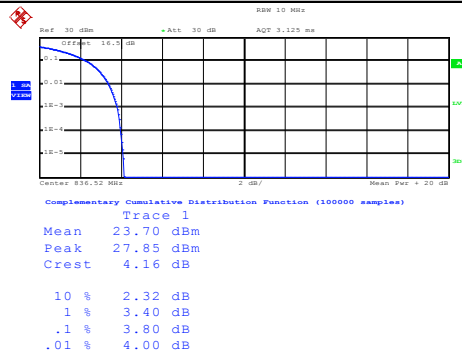

Date: 7.JUL.2016 20:37:28

Highest Channel

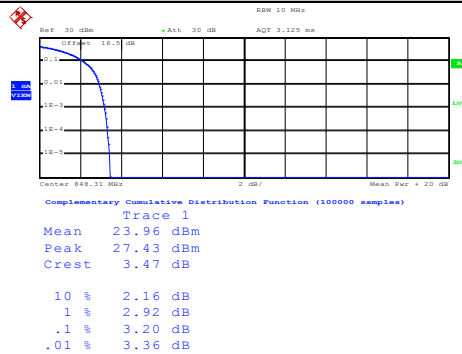

Date: 7.JUL.2016 20:37:37



26dB Bandwidth

Mode	CDMA BC0
Mod.	1xRTT
Lowest CH	1.44
Middle CH	1.45
Highest CH	1.45



CDMA BC0 (1xRTT)

Lowest Channel

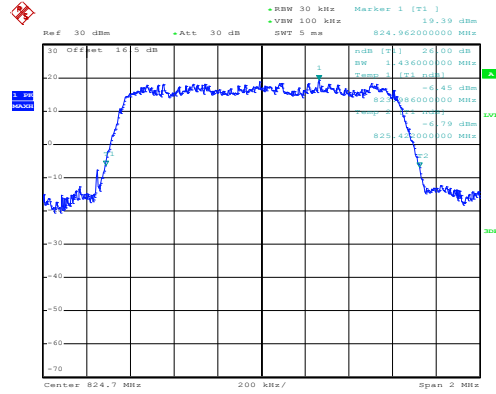

Date: 7.JUL.2016 20:14:18

Middle Channel

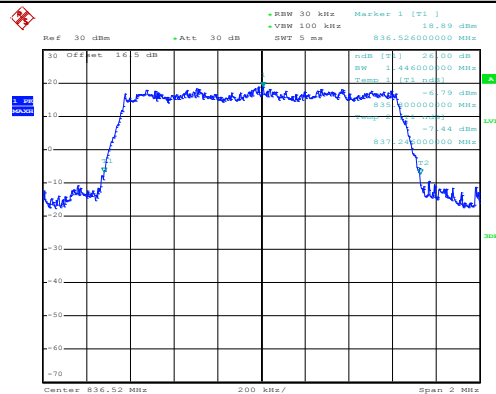

Date: 7.JUL.2016 20:14:46

Highest Channel

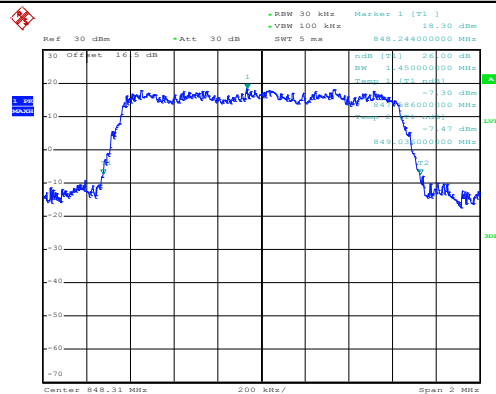

Date: 7.JUL.2016 20:15:14



Occupied Bandwidth

Mode	CDMA BC0
Mod.	1xRTT
Lowest CH	1.28
Middle CH	1.28
Highest CH	1.28



Conducted Band Edge

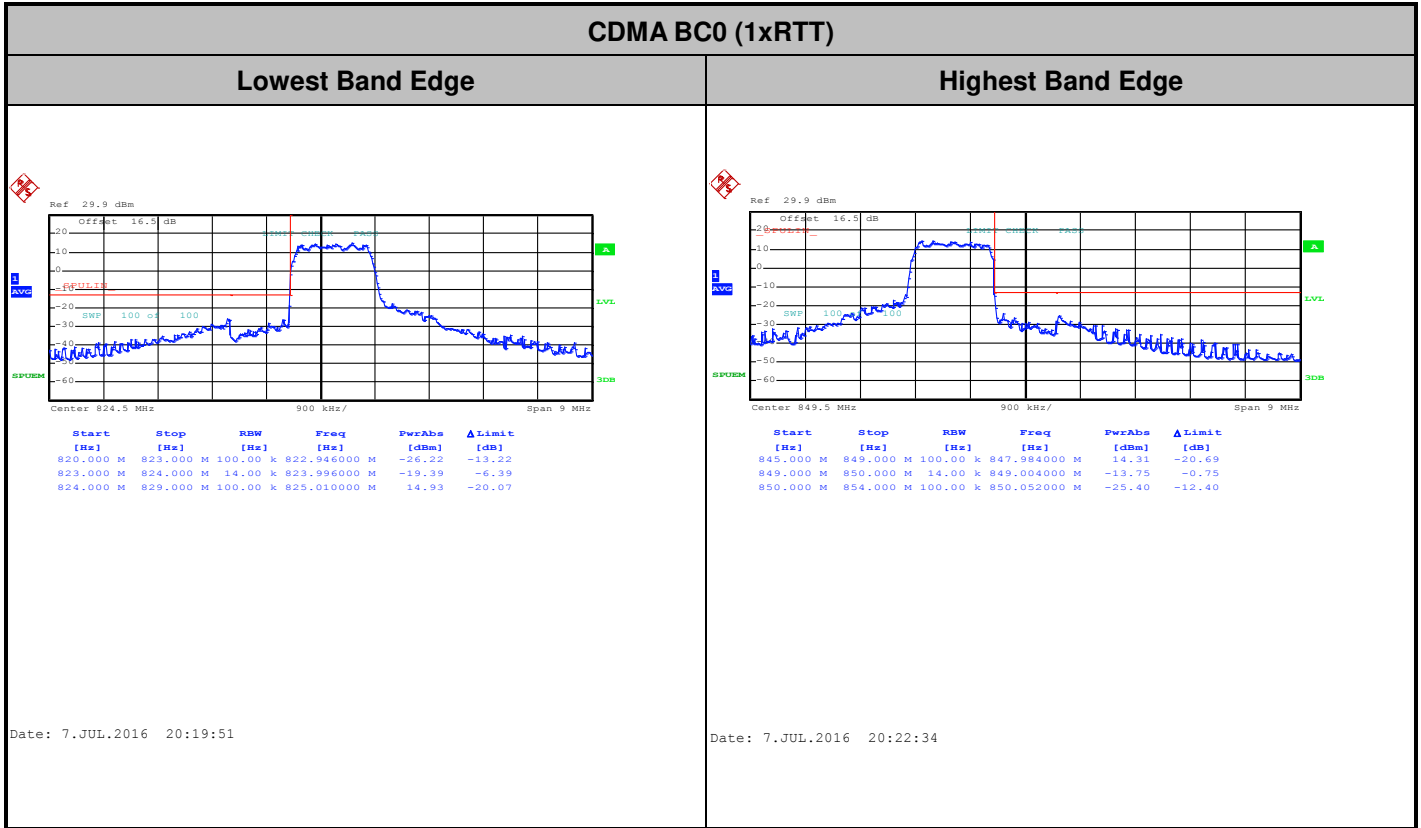



Conducted Spurious Emission



CDMA BC0 (1xRTT)

Lowest Channel

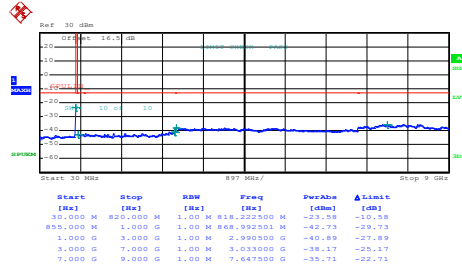

Date: 7.JUL.2016 20:35:06

Middle Channel

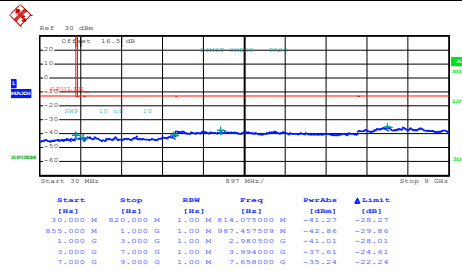

Date: 7.JUL.2016 20:35:53

Highest Channel

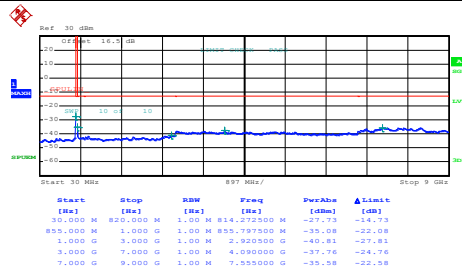

Date: 7.JUL.2016 20:36:39



Frequency Stability

Test Conditions	Middle Channel	CDMA BC0 (1xRTT)	Limit
Temperature (°C)	Voltage (Volt)	Deviation (ppm)	2.5ppm Result
50	Normal Voltage	0.0048	PASS
40	Normal Voltage	0.0000	
30	Normal Voltage	0.0060	
20(Ref.)	Normal Voltage	0.0000	
10	Normal Voltage	0.0024	
0	Normal Voltage	0.0024	
-10	Normal Voltage	0.0048	
-20	Normal Voltage	0.0060	
-30	Normal Voltage	0.0120	
20	Maximum Voltage	0.0048	
20	Normal Voltage	0.0012	
20	Battery End Point	0.0024	

Note:

- 1. Normal Voltage = 3.3V. ; Battery End Point (BEP) = 3.0 V. ; Maximum Voltage =3.6 V
- 2. The frequency fundamental emissions stay within the authorized frequency block.



Appendix B. Test Results of Radiated Test

ERP/EIRP

<Top Ant.>

Channel	Mode	Horizontal		Vertical	
		ERP(dBm)	ERP(W)	ERP(dBm)	ERP(W)
Lowest	GSM850 GSM	4.98	0.0031	10.65	0.0116
Middle		4.34	0.0027	9.59	0.0091
Highest		4.12	0.0026	8.71	0.0074
Lowest	GSM850 EDGE class 8	0.52	0.0011	6.22	0.0042
Middle		-0.76	0.0008	4.52	0.0028
Highest		-1.62	0.0007	2.96	0.0020
Lowest	WCDMA Band V AMR 12.2Kbps	3.77	0.0024	7.48	0.0056
Middle		5.23	0.0033	8.87	0.0077
Highest		6.69	0.0047	9.78	0.0095
Lowest	CDMA BC0 1xRTT	4.00	0.0025	8.17	0.0066
Middle		4.93	0.0031	9.65	0.0092
Highest		7.61	0.0058	11.16	0.0131
Limit	ERP < 7W	Result		PASS	

Channel	Mode	Horizontal		Vertical	
		EIRP(dBm)	EIRP(W)	EIRP(dBm)	EIRP(W)
Lowest	GSM1900 GSM	21.91	0.1552	16.00	0.0398
Middle		22.55	0.1799	16.57	0.0454
Highest		22.95	0.1972	17.67	0.0585
Lowest	GSM1900 EDGE class 8	19.37	0.0865	13.73	0.0236
Middle		19.63	0.0918	13.71	0.0235
Highest		20.07	0.1016	14.86	0.0306
Lowest	WCDMA Band II AMR 12.2Kbps	7.43	0.0055	12.77	0.0189
Middle		9.10	0.0081	13.47	0.0222
Highest		9.60	0.0091	13.60	0.0229
Limit	EIRP < 2W	Result		PASS	

Channel	Mode	Horizontal		Vertical	
		EIRP(dBm)	EIRP(W)	EIRP(dBm)	EIRP(W)
Lowest	WCDMA Band IV AMR 12.2Kbps	-0.07	0.0010	7.24	0.0053
Middle		1.97	0.0016	8.17	0.0066
Highest		3.93	0.0025	9.01	0.0080
Limit	EIRP < 1W	Result		PASS	



<Bottom Ant.>

Channel	Mode	Horizontal		Vertical	
		ERP(dBm)	ERP(W)	ERP(dBm)	ERP(W)
Lowest	GSM850 GSM	18.36	0.0685	24.19	0.2624
Middle		19.14	0.0820	24.42	0.2767
Highest		19.60	0.0912	24.46	0.2793
Lowest	GSM850 EDGE class 8	11.92	0.0156	18.03	0.0635
Middle		12.94	0.0197	18.16	0.0655
Highest		13.41	0.0219	18.19	0.0659
Lowest	WCDMA Band V AMR 12.2Kbps	9.85	0.0097	15.17	0.0329
Middle		10.12	0.0103	15.16	0.0328
Highest		10.09	0.0102	14.55	0.0285
Lowest	CDMA BC0 1xRTT	9.88	0.0097	15.04	0.0319
Middle		9.96	0.0099	14.93	0.0311
Highest		10.02	0.0100	14.24	0.0265
Limit	ERP < 7W	Result		PASS	

Channel	Mode	Horizontal		Vertical	
		EIRP(dBm)	EIRP(W)	EIRP(dBm)	EIRP(W)
Lowest	GSM1900 GSM	30.52	1.1272	24.92	0.3105
Middle		29.70	0.9333	23.94	0.2477
Highest		29.86	0.9683	24.77	0.2999
Lowest	GSM1900 EDGE class 8	27.01	0.5023	21.30	0.1349
Middle		26.36	0.4325	20.26	0.1062
Highest		26.89	0.4887	21.77	0.1503
Lowest	WCDMA Band II AMR 12.2Kbps	23.95	0.2483	18.45	0.0700
Middle		23.87	0.2438	18.16	0.0655
Highest		23.77	0.2382	18.65	0.0733
Limit	EIRP < 2W	Result		PASS	

Channel	Mode	Horizontal		Vertical	
		EIRP(dBm)	EIRP(W)	EIRP(dBm)	EIRP(W)
Lowest	WCDMA Band IV AMR 12.2Kbps	20.81	0.1205	13.46	0.0222
Middle		20.69	0.1172	13.64	0.0231
Highest		21.40	0.1380	14.45	0.0279
Limit	EIRP < 1W	Result		PASS	



Radiated Spurious Emission

<Top Antenna with SIM 1>

GSM850 (GSM)									
Channel	Frequency (MHz)	ERP (dBm)	Limit (dBm)	Over Limit (dB)	SPA Reading (dBm)	S.G. Power (dBm)	TX Cable loss (dB)	TX Antenna Gain (dBi)	Polarization (H/V)
Lowest	1648	-62.34	-13	-49.34	-66.84	-64.1	0.98	4.89	H
	2472	-56.42	-13	-43.42	-65.67	-58.3	1.28	5.32	H
	3296	-64.69	-13	-51.69	-76.86	-68.1	1.54	7.10	H
	1648	-62.44	-13	-49.44	-65.42	-64.2	0.98	4.89	V
	2472	-58.42	-13	-45.42	-68.58	-60.3	1.28	5.32	V
	3296	-64.99	-13	-51.99	-76.46	-68.4	1.54	7.10	V
Middle	1672	-65.12	-13	-52.12	-69.67	-66.8	0.99	4.82	H
	2512	-54.83	-13	-41.83	-64.05	-56.8	1.29	5.41	H
	3345	-64.59	-13	-51.59	-76.52	-68.2	1.56	7.32	H
	1672	-68.12	-13	-55.12	-70.88	-69.8	0.99	4.82	V
	2509	-55.54	-13	-42.54	-66.17	-57.5	1.29	5.41	V
	3345	-65.09	-13	-52.09	-76.24	-68.7	1.56	7.32	V
Highest	1696	-68.30	-13	-55.30	-73.54	-69.9	1.00	4.75	H
	2544	-54.62	-13	-41.62	-2544	-56.6	1.30	5.44	H
	3393	-64.39	-13	-51.39	-33.93	-68.2	1.57	7.53	H
	1696	-68.10	-13	-55.10	-71.92	-69.7	1.00	4.75	V
	2544	-56.92	-13	-43.92	-66.89	-58.9	1.30	5.44	V
	3393	-64.79	-13	-51.79	-76.43	-68.6	1.57	7.53	V

Remark: Spurious emissions within 30-1000MHz were found more than 20dB below limit line.



GSM850 (EDGE class 8)									
Channel	Frequency (MHz)	ERP (dBm)	Limit (dBm)	Over Limit (dB)	SPA Reading (dBm)	S.G. Power (dBm)	TX Cable loss (dB)	TX Antenna Gain (dBi)	Polarization (H/V)
Lowest	1648	-69.04	-13	-56.04	-74.16	-70.8	0.98	4.89	H
	2472	-62.52	-13	-49.52	-72.12	-64.4	1.28	5.32	H
	3296	-64.49	-13	-51.49	-76.66	-67.9	1.54	7.10	H
	1648	-70.74	-13	-57.74	-73.59	-72.5	0.98	4.89	V
	2472	-63.52	-13	-50.52	-73.85	-65.4	1.28	5.32	V
	3296	-65.89	-13	-52.89	-76.68	-69.3	1.54	7.10	V
Middle	1672	-69.52	-13	-56.52	-74.27	-71.2	0.99	4.82	H
	2512	-63.63	-13	-50.63	-73.05	-65.6	1.29	5.41	H
	3345	-64.69	-13	-51.69	-76.51	-68.3	1.56	7.32	H
	1672	-71.12	-13	-58.12	-74.14	-72.8	0.99	4.82	V
	2512	-62.13	-13	-49.13	-72.27	-64.1	1.29	5.41	V
	3345	-65.19	-13	-52.19	-76.31	-68.8	1.56	7.32	V
Highest	1696	-67.30	-13	-54.30	-72.07	-68.9	1.00	4.75	H
	2544	-64.32	-13	-51.32	-73.57	-66.3	1.30	5.44	H
	3392	-64.60	-13	-51.60	-76.57	-68.4	1.57	7.52	H
	1696	-67.50	-13	-54.50	-71.23	-69.1	1.00	4.75	V
	2544	-64.12	-13	-51.12	-74.31	-66.1	1.30	5.44	V
	3393	-65.09	-13	-52.09	-76.59	-68.9	1.57	7.53	V

Remark: Spurious emissions within 30-1000MHz were found more than 20dB below limit line.



GSM1900 (GPRS class 8)									
Channel	Frequency (MHz)	EIRP (dBm)	Limit (dBm)	Over Limit (dB)	SPA Reading (dBm)	S.G. Power (dBm)	TX Cable loss (dB)	TX Antenna Gain (dBi)	Polarization (H/V)
Lowest	3700	-56.03	-13	-43.03	-70.25	-62.6	1.67	8.24	H
	5548	-46.13	-13	-33.13	-65.04	-53.2	2.65	9.72	H
	7403	-48.35	-13	-35.35	-73.46	-57.5	2.46	11.61	H
	3700	-56.03	-13	-43.03	-70.06	-62.6	1.67	8.24	V
	5548	-51.63	-13	-38.63	-69.81	-58.7	2.65	9.72	V
	7403	-52.95	-13	-39.95	-76.74	-62.1	2.46	11.61	V
Middle	3763	-58.17	-13	-45.17	-72.92	-64.8	1.69	8.32	H
	5639	-45.55	-13	-32.55	-65.46	-52.6	2.71	9.76	H
	7522	-50.11	-13	-37.11	-74.95	-59.5	2.42	11.81	H
	3763	-56.57	-13	-43.57	-70.59	-63.2	1.69	8.32	V
	5639	-50.75	-13	-37.75	-68.67	-57.8	2.71	9.76	V
	7522	-52.51	-13	-39.51	-76.17	-61.9	2.42	11.81	V
Highest	3819	-59.53	-13	-46.53	-74.31	-66.21	1.70	8.38	H
	5730	-50.34	-13	-37.34	-70.49	-57.37	2.76	9.79	H
	7641	-52.20	-13	-39.20	-76.9	-61.7	2.38	11.88	H
	3819	-62.17	-13	-49.17	-76.3	-68.85	1.70	8.38	V
	5730	-53.12	-13	-40.12	-72.1	-60.15	2.76	9.79	V
	7641	-54.08	-13	-41.08	-78.08	-63.58	2.38	11.88	V

Remark: Spurious emissions within 30-1000MHz were found more than 20dB below limit line.



GSM1900 (EDGE class 8)									
Channel	Frequency (MHz)	EIRP (dBm)	Limit (dBm)	Over Limit (dB)	SPA Reading (dBm)	S.G. Power (dBm)	TX Cable loss (dB)	TX Antenna Gain (dBi)	Polarization (H/V)
Lowest	3700	-60.61	-13	-47.61	-75.1	-67.18	1.67	8.24	H
	5548	-51.21	-13	-38.21	-71.33	-58.28	2.65	9.72	H
	7403	-52.05	-13	-39.05	-77.52	-61.2	2.46	11.61	H
	3700	-62.50	-13	-49.50	-76.9	-69.07	1.67	8.24	V
	5548	-56.38	-13	-43.38	-74.96	-63.45	2.65	9.72	V
	7403	-54.70	-13	-41.70	-78.96	-63.85	2.46	11.61	V
Middle	3763	-60.68	-13	-47.68	-75.38	-67.31	1.69	8.32	H
	5639	-54.66	-13	-41.66	-74.56	-61.71	2.71	9.76	H
	7522	-51.24	-13	-38.24	-76.23	-60.63	2.42	11.81	H
	3763	-60.68	-13	-47.68	-75.38	-67.31	1.69	8.32	V
	5639	-54.66	-13	-41.66	-74.56	-61.71	2.71	9.76	V
	7522	-51.24	-13	-38.24	-76.23	-60.63	2.42	11.81	V
Highest	3819	-56.52	-13	-43.52	-71.43	-63.2	1.70	8.38	H
	5730	-45.67	-13	-32.67	-65.59	-52.7	2.76	9.79	H
	7641	-54.60	-13	-41.60	-78.73	-64.1	2.38	11.88	H
	3819	-55.72	-13	-42.72	-69.61	-62.4	1.70	8.38	V
	5730	-50.57	-13	-37.57	-69.13	-57.6	2.76	9.79	V
	7641	-54.80	-13	-41.80	-78.82	-64.3	2.38	11.88	V

Remark: Spurious emissions within 30-1000MHz were found more than 20dB below limit line.



WCDMA Band V (RMC 12.2Kbps)									
Channel	Frequency (MHz)	ERP (dBm)	Limit (dBm)	Over Limit (dB)	SPA Reading (dBm)	S.G. Power (dBm)	TX Cable loss (dB)	TX Antenna Gain (dBi)	Polarization (H/V)
Lowest	1648	-68.34	-13	-55.34	-72.9	-70.1	0.98	4.89	H
	2480	-58.89	-13	-45.89	-68.16	-60.8	1.28	5.34	H
	3305	-64.45	-13	-51.45	-76.69	-67.9	1.54	7.14	H
	1648	-71.04	-13	-58.04	-74.24	-72.8	0.98	4.89	V
	2480	-56.79	-13	-43.79	-67.02	-58.7	1.28	5.34	V
	3305	-65.65	-13	-52.65	-76.83	-69.1	1.54	7.14	V
Middle	1672	-68.72	-13	-55.72	-73.47	-70.4	0.99	4.82	H
	2512	-60.53	-13	-47.53	-69.96	-62.5	1.29	5.41	H
	3345	-64.49	-13	-51.49	-76.19	-68.1	1.56	7.32	H
	1672	-69.82	-13	-56.82	-72.84	-71.5	0.99	4.82	V
	2512	-59.43	-13	-46.43	-69.62	-61.4	1.29	5.41	V
	3345	-64.89	-13	-51.89	-75.94	-68.5	1.56	7.32	V
Highest	1688	-69.27	-13	-56.27	-73.86	-70.9	1.00	4.77	H
	2536	-60.82	-13	-47.82	-70.25	-62.8	1.30	5.43	H
	3386	-64.52	-13	-51.52	-76.58	-68.3	1.57	7.50	H
	1696	-70.30	-13	-57.30	-73.92	-71.9	1.00	4.75	V
	2536	-58.92	-13	-45.92	-69.19	-60.9	1.30	5.43	V
	3386	-65.02	-13	-52.02	-76.52	-68.8	1.57	7.50	V

Remark: Spurious emissions within 30-1000MHz were found more than 20dB below limit line.



WCDMA Band II (RMC 12.2Kbps)									
Channel	Frequency (MHz)	EIRP (dBm)	Limit (dBm)	Over Limit (dB)	SPA Reading (dBm)	S.G. Power (dBm)	TX Cable loss (dB)	TX Antenna Gain (dBi)	Polarization (H/V)
Lowest	3707	-62.86	-13	-49.86	-77.35	-69.44	1.67	8.25	H
	5562	-58.73	-13	-45.73	-78.85	-65.79	2.66	9.72	H
	7410	-53.17	-13	-40.17	-78.64	-62.33	2.46	11.62	H
	3707	-62.68	-13	-49.68	-77.08	-69.26	1.67	8.25	V
	5562	-60.21	-13	-47.21	-78.79	-67.27	2.66	9.72	V
	7410	-54.27	-13	-41.27	-78.53	-63.43	2.46	11.62	V
Middle	3756	-62.75	-13	-49.75	-77.43	-69.37	1.68	8.31	H
	5639	-59.00	-13	-46.00	-78.9	-66.05	2.71	9.76	H
	7522	-53.59	-13	-40.59	-78.58	-62.98	2.42	11.81	H
	3760	-63.30	-13	-50.30	-77.68	-69.93	1.69	8.31	V
	5639	-60.48	-13	-47.48	-78.88	-67.53	2.71	9.76	V
	7522	-54.74	-13	-41.74	-78.83	-64.13	2.42	11.81	V
Highest	3819	-62.16	-13	-49.16	-76.94	-68.84	1.70	8.38	H
	5723	-58.55	-13	-45.55	-78.7	-65.59	2.75	9.79	H
	7627	-53.86	-13	-40.86	-78.56	-63.35	2.39	11.88	H
	3815	-62.89	-13	-49.89	-77.02	-69.56	1.70	8.38	V
	5723	-59.96	-13	-46.96	-78.97	-67	2.75	9.79	V
	7634	-54.59	-13	-41.59	-78.59	-64.08	2.39	11.88	V

Remark: Spurious emissions within 30-1000MHz were found more than 20dB below limit line.



WCDMA Band IV (RMC 12.2Kbps)									
Channel	Frequency (MHz)	EIRP (dBm)	Limit (dBm)	Over Limit (dB)	SPA Reading (dBm)	S.G. Power (dBm)	TX Cable loss (dB)	TX Antenna Gain (dBi)	Polarization (H/V)
Lowest	3427	-63.58	-13	-50.58	-76.19	-69.68	1.58	7.68	H
	5137	-59.03	-13	-46.03	-78.22	-66.31	2.42	9.70	H
	6850	-55.69	-13	-42.69	-78.91	-63.67	2.64	10.62	H
	3427	-63.75	-13	-50.75	-76.24	-69.85	1.58	7.68	V
	5137	-60.19	-13	-47.19	-78.25	-67.47	2.42	9.70	V
	6850	-56.04	-13	-43.04	-78.94	-64.02	2.64	10.62	V
Middle	3469	-63.36	-13	-50.36	-76.3	-69.63	1.59	7.86	H
	5198	-58.58	-13	-45.58	-77.9	-65.83	2.45	9.70	H
	6934	-55.60	-13	-42.60	-79.04	-63.71	2.61	10.72	H
	3462	-62.73	-13	-49.73	-75.91	-68.97	1.59	7.83	V
	5198	-59.64	-13	-46.64	-77.99	-66.89	2.45	9.70	V
	6934	-55.65	-13	-42.65	-78.85	-63.76	2.61	10.72	V
Highest	3504	-62.94	-13	-49.94	-76.22	-69.34	1.61	8.00	H
	5261	-59.37	-13	-46.37	-78.65	-66.58	2.49	9.70	H
	7011	-55.32	-13	-42.32	-79.03	-63.56	2.59	10.82	H
	3504	-62.10	-13	-49.10	-75.97	-68.5	1.61	8.00	V
	5261	-59.93	-13	-46.93	-78.56	-67.14	2.49	9.70	V
	7011	-55.48	-13	-42.48	-79.02	-63.72	2.59	10.82	V

Remark: Spurious emissions within 30-1000MHz were found more than 20dB below limit line.



CDMA BC0 (1xRTT)									
Channel	Frequency (MHz)	ERP (dBm)	Limit (dBm)	Over Limit (dB)	SPA Reading (dBm)	S.G. Power (dBm)	TX Cable loss (dB)	TX Antenna Gain (dBi)	Polarization (H/V)
Lowest	1648	-62.14	-13	-49.14	-66.87	-63.9	0.98	4.89	H
	2472	-61.22	-13	-48.22	-70.43	-63.1	1.28	5.32	H
	3298	-64.48	-13	-51.48	-76.67	-67.9	1.54	7.11	H
	1648	-65.74	-13	-52.74	-68.45	-67.5	0.98	4.89	V
	2472	-61.62	-13	-48.62	-71.74	-63.5	1.28	5.32	V
	3298	-65.68	-13	-52.68	-76.68	-69.1	1.54	7.11	V
Middle	1672	-65.22	-13	-52.22	-69.17	-66.9	0.99	4.82	H
	2512	-60.63	-13	-47.63	-70.1	-62.6	1.29	5.41	H
	3345	-64.29	-13	-51.29	-76.28	-67.9	1.56	7.32	H
	1672	-67.42	-13	-54.42	-70.24	-69.1	0.99	4.82	V
	2512	-67.43	-13	-54.43	-69.53	-69.4	1.29	5.41	V
	3345	-64.99	-13	-51.99	-76.1	-68.6	1.56	7.32	V
Highest	1696	-68.10	-13	-55.10	-72.42	-69.7	1.00	4.75	H
	2544	-58.62	-13	-45.62	-68.04	-60.6	1.30	5.44	H
	3393	-64.39	-13	-51.39	-76.43	-68.2	1.57	7.53	H
	1696	-68.90	-13	-55.90	-72.28	-70.5	1.00	4.75	V
	2544	-61.12	-13	-48.12	-71.21	-63.1	1.30	5.44	V
	3393	-64.89	-13	-51.89	-76.56	-68.7	1.57	7.53	V

Remark: Spurious emissions within 30-1000MHz were found more than 20dB below limit line.



<Bottom Antenna with SIM 1>

GSM850 (GSM)									
Channel	Frequency (MHz)	ERP (dBm)	Limit (dBm)	Over Limit (dB)	SPA Reading (dBm)	S.G. Power (dBm)	TX Cable loss (dB)	TX Antenna Gain (dBi)	Polarization (H/V)
Lowest	1648	-56.44	-13	-43.44	-60.89	-58.2	0.98	4.89	H
	2472	-49.72	-13	-36.72	-58.7	-51.6	1.28	5.32	H
	3296	-63.09	-13	-50.09	-75.56	-66.5	1.54	7.10	H
	1648	-53.04	-13	-40.04	-55.76	-54.8	0.98	4.89	V
	2472	-41.62	-13	-28.62	-51.59	-43.5	1.28	5.32	V
	3296	-62.89	-13	-49.89	-74.55	-66.3	1.54	7.10	V
	5768	-56.62	-13	-43.62	-75.71	-61.5	2.78	9.81	V
Middle	1672	-55.02	-13	-42.02	-59.12	-56.7	0.99	4.82	H
	2509	-46.24	-13	-33.24	-55.65	-48.2	1.29	5.41	H
	3345	-64.59	-13	-51.59	-76.27	-68.2	1.56	7.32	H
	1672	-54.12	-13	-41.12	-56.98	-55.8	0.99	4.82	V
	2509	-41.64	-13	-28.64	-51.37	-43.6	1.29	5.41	V
	3345	-65.39	-13	-52.39	-76.42	-69	1.56	7.32	V
	5856	-56.04	-13	-43.04	-76.1	-60.9	2.83	9.84	V
Highest	1696	-52.00	-13	-39.00	-56.55	-53.6	1.00	4.75	H
	2544	-43.12	-13	-30.12	-52.54	-45.1	1.30	5.44	H
	3393	-63.99	-13	-50.99	-75.89	-67.8	1.57	7.53	H
	1696	-46.50	-13	-33.50	-49.85	-48.1	1.00	4.75	V
	2544	-39.42	-13	-26.42	-49.49	-41.4	1.30	5.44	V
	3393	-64.89	-13	-51.89	-76.16	-68.7	1.57	7.53	V
	5944	-56.55	-13	-43.55	-77.23	-61.4	2.88	9.88	V

Remark: Spurious emissions within 30-1000MHz were found more than 20dB below limit line.



GSM850 (EDGE class 8)									
Channel	Frequency (MHz)	ERP (dBm)	Limit (dBm)	Over Limit (dB)	SPA Reading (dBm)	S.G. Power (dBm)	TX Cable loss (dB)	TX Antenna Gain (dBi)	Polarization (H/V)
Lowest	1648	-63.84	-13	-50.84	-68.34	-65.6	0.98	4.89	H
	2472	-62.92	-13	-49.92	-72.07	-64.8	1.28	5.32	H
	3296	-64.29	-13	-51.29	-76.43	-67.7	1.54	7.10	H
	1648	-65.34	-13	-52.34	-68.48	-67.1	0.98	4.89	V
	2472	-59.02	-13	-46.02	-69.47	-60.9	1.28	5.32	V
	3296	-65.49	-13	-52.49	-76.71	-68.9	1.54	7.10	V
Middle	1672	-63.92	-13	-50.92	-68.48	-65.6	0.99	4.82	H
	2512	-61.43	-13	-48.43	-70.91	-63.4	1.29	5.41	H
	3345	-64.49	-13	-51.49	-76.46	-68.1	1.56	7.32	H
	1672	-64.72	-13	-51.72	-67.7	-66.4	0.99	4.82	V
	2512	-56.13	-13	-43.13	-65.86	-58.1	1.29	5.41	V
	3345	-65.49	-13	-52.49	-76.52	-69.1	1.56	7.32	V
Highest	1696	-64.30	-13	-51.30	-68.98	-65.9	1.00	4.75	H
	2544	-65.02	-13	-52.02	-74.23	-67	1.30	5.44	H
	3393	-64.39	-13	-51.39	-76.46	-68.2	1.57	7.53	H
	1696	-66.30	-13	-53.30	-69.93	-67.9	1.00	4.75	V
	2544	-59.52	-13	-46.52	-69.63	-61.5	1.30	5.44	V
	3393	-64.29	-13	-51.29	-75.91	-68.1	1.57	7.53	V

Remark: Spurious emissions within 30-1000MHz were found more than 20dB below limit line.



GSM1900 (GPRS class 8)									
Channel	Frequency (MHz)	EIRP (dBm)	Limit (dBm)	Over Limit (dB)	SPA Reading (dBm)	S.G. Power (dBm)	TX Cable loss (dB)	TX Antenna Gain (dBi)	Polarization (H/V)
Lowest	3700	-52.83	-13	-39.83	-67.23	-59.4	1.67	8.24	H
	5548	-43.93	-13	-30.93	-63.88	-51	2.65	9.72	H
	7403	-51.95	-13	-38.95	-77.06	-61.1	2.46	11.61	H
	3700	-51.03	-13	-38.03	-65.36	-57.6	1.67	8.24	V
	5548	-43.43	-13	-30.43	-61.67	-50.5	2.65	9.72	V
	7403	-52.65	-13	-39.65	-76.52	-61.8	2.46	11.61	V
	9251	-50.84	-13	-37.84	-77.04	-60.9	2.54	12.60	V
Middle	3763	-52.17	-13	-39.17	-66.79	-58.8	1.69	8.32	H
	5639	-46.85	-13	-33.85	-66.68	-53.9	2.71	9.76	H
	7522	-53.01	-13	-40.01	-77.85	-62.4	2.42	11.81	H
	3763	-52.87	-13	-39.87	-67.13	-59.5	1.69	8.32	V
	5639	-46.45	-13	-33.45	-64.43	-53.5	2.71	9.76	V
	7522	-52.91	-13	-39.91	-76.72	-62.3	2.42	11.81	V
Highest	3819	-55.62	-13	-42.62	-70.28	-62.3	1.70	8.38	H
	5730	-44.77	-13	-31.77	-64.79	-51.8	2.76	9.79	H
	7641	-51.60	-13	-38.60	-75.81	-61.1	2.38	11.88	H
	3819	-52.92	-13	-39.92	-66.72	-59.6	1.70	8.38	V
	5730	-40.07	-13	-27.07	-58.91	-47.1	2.76	9.79	V
	7641	-50.70	-13	-37.70	-74.27	-60.2	2.38	11.88	V

Remark: Spurious emissions within 30-1000MHz were found more than 20dB below limit line.



GSM1900 (EDGE class 8)									
Channel	Frequency (MHz)	EIRP (dBm)	Limit (dBm)	Over Limit (dB)	SPA Reading (dBm)	S.G. Power (dBm)	TX Cable loss (dB)	TX Antenna Gain (dBi)	Polarization (H/V)
Lowest	3700	-58.53	-13	-45.53	-72.73	-65.1	1.67	8.24	H
	5548	-52.13	-13	-39.13	-72.03	-59.2	2.65	9.72	H
	7403	-53.25	-13	-40.25	-78.66	-62.4	2.46	11.61	H
	3700	-56.33	-13	-43.33	-70.58	-62.9	1.67	8.24	V
	5548	-51.03	-13	-38.03	-69.32	-58.1	2.65	9.72	V
	7403	-54.45	-13	-41.45	-78.74	-63.6	2.46	11.61	V
Middle	3763	-60.47	-13	-47.47	-74.94	-67.1	1.69	8.32	H
	5639	-50.15	-13	-37.15	-69.96	-57.2	2.71	9.76	H
	7522	-52.71	-13	-39.71	-77.44	-62.1	2.42	11.81	H
	3763	-60.87	-13	-47.87	-75	-67.5	1.69	8.32	V
	5639	-52.05	-13	-39.05	-70.2	-59.1	2.71	9.76	V
	7522	-51.21	-13	-38.21	-75.2	-60.6	2.42	11.81	V
Highest	3819	-60.42	-13	-47.42	-75.06	-67.1	1.70	8.38	H
	5730	-49.07	-13	-36.07	-69.09	-56.1	2.76	9.79	H
	7641	-54.60	-13	-41.60	-78.96	-64.1	2.38	11.88	H
	3819	-60.42	-13	-47.42	-74.32	-67.1	1.70	8.38	V
	5730	-49.87	-13	-36.87	-68.18	-56.9	2.76	9.79	V
	7641	-53.70	-13	-40.70	-77.61	-63.2	2.38	11.88	V

Remark: Spurious emissions within 30-1000MHz were found more than 20dB below limit line.



WCDMA Band V (RMC 12.2Kbps)									
Channel	Frequency (MHz)	ERP (dBm)	Limit (dBm)	Over Limit (dB)	SPA Reading (dBm)	S.G. Power (dBm)	TX Cable loss (dB)	TX Antenna Gain (dBi)	Polarization (H/V)
Lowest	1648	-64.44	-13	-51.44	-69.03	-66.2	0.98	4.89	H
	2480	-59.69	-13	-46.69	-68.97	-61.6	1.28	5.34	H
	3305	-64.05	-13	-51.05	-76.33	-67.5	1.54	7.14	H
	1648	-66.04	-13	-53.04	-68.94	-67.8	0.98	4.89	V
	2480	-53.29	-13	-40.29	-63.18	-55.2	1.28	5.34	V
	3305	-65.25	-13	-52.25	-76.52	-68.7	1.54	7.14	V
Middle	1672	-65.82	-13	-52.82	-70.06	-67.5	0.99	4.82	H
	2512	-58.63	-13	-45.63	-68.11	-60.6	1.29	5.41	H
	3345	-64.19	-13	-51.19	-76.2	-67.8	1.56	7.32	H
	1672	-65.92	-13	-52.92	-68.82	-67.6	0.99	4.82	V
	2512	-52.53	-13	-39.53	-62.65	-54.5	1.29	5.41	V
	3345	-65.39	-13	-52.39	-76.19	-69	1.56	7.32	V
Highest	1688	-66.87	-13	-53.87	-71.08	-68.5	1.00	4.77	H
	2536	-61.02	-13	-48.02	-70.37	-63	1.30	5.43	H
	3386	-64.02	-13	-51.02	-76.14	-67.8	1.57	7.50	H
	1696	-67.30	-13	-54.30	-71	-68.9	1.00	4.75	V
	2536	-54.82	-13	-41.82	-64.72	-56.8	1.30	5.43	V
	3386	-64.62	-13	-51.62	-76.22	-68.4	1.57	7.50	V

Remark: Spurious emissions within 30-1000MHz were found more than 20dB below limit line.



WCDMA Band II (RMC 12.2Kbps)									
Channel	Frequency (MHz)	EIRP (dBm)	Limit (dBm)	Over Limit (dB)	SPA Reading (dBm)	S.G. Power (dBm)	TX Cable loss (dB)	TX Antenna Gain (dBi)	Polarization (H/V)
Lowest	3707	-61.52	-13	-48.52	-75.98	-68.1	1.67	8.25	H
	5562	-47.24	-13	-34.24	-67.27	-54.3	2.66	9.72	H
	7410	-53.64	-13	-40.64	-78.85	-62.8	2.46	11.62	H
	3707	-61.62	-13	-48.62	-76.02	-68.2	1.67	8.25	V
	5562	-47.94	-13	-34.94	-66.04	-55	2.66	9.72	V
	7410	-53.94	-13	-40.94	-77.85	-63.1	2.46	11.62	V
Middle	3756	-61.68	-13	-48.68	-76.26	-68.3	1.68	8.31	H
	5639	-50.75	-13	-37.75	-70.25	-57.8	2.71	9.76	H
	7522	-51.01	-13	-38.01	-75.82	-60.4	2.42	11.81	H
	3760	-61.87	-13	-48.87	-76.37	-68.5	1.69	8.31	V
	5639	-52.85	-13	-39.85	-70.97	-59.9	2.71	9.76	V
	7522	-52.71	-13	-39.71	-76.52	-62.1	2.42	11.81	V
Highest	3819	-61.42	-13	-48.42	-76.2	-68.1	1.70	8.38	H
	5723	-53.56	-13	-40.56	-73.33	-60.6	2.75	9.79	H
	7627	-51.21	-13	-38.21	-75.64	-60.7	2.39	11.88	H
	3815	-62.43	-13	-49.43	-76.39	-69.1	1.70	8.38	V
	5723	-52.76	-13	-39.76	-71.5	-59.8	2.75	9.79	V
	7634	-52.91	-13	-39.91	-76.19	-62.4	2.39	11.88	V

Remark: Spurious emissions within 30-1000MHz were found more than 20dB below limit line.



WCDMA Band IV (RMC 12.2Kbps)									
Channel	Frequency (MHz)	EIRP (dBm)	Limit (dBm)	Over Limit (dB)	SPA Reading (dBm)	S.G. Power (dBm)	TX Cable loss (dB)	TX Antenna Gain (dBi)	Polarization (H/V)
Lowest	3427	-60.00	-13	-47.00	-72.18	-66.1	1.58	7.68	H
	5137	-58.92	-13	-45.92	-77.97	-66.2	2.42	9.70	H
	6850	-54.82	-13	-41.82	-77.92	-62.8	2.64	10.62	H
	3420	-62.73	-13	-49.73	-74.86	-68.8	1.58	7.65	V
	5135	-60.01	-13	-47.01	-77.83	-67.3	2.41	9.70	V
	6850	-56.02	-13	-43.02	-78.86	-64	2.64	10.62	V
Middle	3469	-58.53	-13	-45.53	-71.2	-64.8	1.59	7.86	H
	5198	-58.55	-13	-45.55	-77.5	-65.8	2.45	9.70	H
	6934	-52.39	-13	-39.39	-75.33	-60.5	2.61	10.72	H
	3462	-59.86	-13	-46.86	-72.68	-66.1	1.59	7.83	V
	5198	-59.85	-13	-46.85	-77.96	-67.1	2.45	9.70	V
	6934	-55.09	-13	-42.09	-78.13	-63.2	2.61	10.72	V
Highest	3504	-55.70	-13	-42.70	-68.47	-62.1	1.61	8.00	H
	5258	-59.59	-13	-46.59	-78.29	-66.8	2.49	9.70	H
	7011	-49.96	-13	-36.96	-73.5	-58.2	2.59	10.82	H
	3504	-59.30	-13	-46.30	-73.13	-65.7	1.61	8.00	V
	5254	-59.98	-13	-46.98	-78.41	-67.2	2.48	9.70	V
	7004	-54.58	-13	-41.58	-77.53	-62.8	2.59	10.81	V

Remark: Spurious emissions within 30-1000MHz were found more than 20dB below limit line.



CDMA BC0 (1xRTT)									
Channel	Frequency (MHz)	ERP (dBm)	Limit (dBm)	Over Limit (dB)	SPA Reading (dBm)	S.G. Power (dBm)	TX Cable loss (dB)	TX Antenna Gain (dBi)	Polarization (H/V)
Lowest	1648	-63.84	-13	-50.84	-67.83	-65.6	0.98	4.89	H
	2472	-48.42	-13	-35.42	-57.73	-50.3	1.28	5.32	H
	3298	-63.78	-13	-50.78	-76.13	-67.2	1.54	7.11	H
	1648	-64.14	-13	-51.14	-67.99	-65.9	0.98	4.89	V
	2472	-40.82	-13	-27.82	-51.14	-42.7	1.28	5.32	V
	3298	-64.78	-13	-51.78	-75.98	-68.2	1.54	7.11	V
Middle	1672	-57.42	-13	-44.42	-61.85	-59.1	0.99	4.82	H
	2512	-47.53	-13	-34.53	-56.98	-49.5	1.29	5.41	H
	3345	-63.89	-13	-50.89	-75.89	-67.5	1.56	7.32	H
	1672	-57.92	-13	-44.92	-60.76	-59.6	0.99	4.82	V
	2512	-43.43	-13	-30.43	-53.52	-45.4	1.29	5.41	V
	3345	-64.99	-13	-51.99	-76.12	-68.6	1.56	7.32	V
Highest	1696	-64.90	-13	-51.90	-69.43	-66.5	1.00	4.75	H
	2544	-46.82	-13	-33.82	-56.29	-48.8	1.30	5.44	H
	3393	-64.29	-13	-51.29	-76.48	-68.1	1.57	7.53	H
	1696	-64.60	-13	-51.60	-68.05	-66.2	1.00	4.75	V
	2544	-45.12	-13	-32.12	-55.06	-47.1	1.30	5.44	V
	3393	-64.29	-13	-51.29	-75.95	-68.1	1.57	7.53	V

Remark: Spurious emissions within 30-1000MHz were found more than 20dB below limit line.



<Bottom Antenna with SIM 2>

GSM850 (GSM)									
Channel	Frequency (MHz)	ERP (dBm)	Limit (dBm)	Over Limit (dB)	SPA Reading (dBm)	S.G. Power (dBm)	TX Cable loss (dB)	TX Antenna Gain (dBi)	Polarization (H/V)
Lowest	1648	-52.74	-13	-39.74	-57.03	-54.5	0.98	4.89	H
	2472	-35.32	-13	-22.32	-44.59	-37.2	1.28	5.32	H
	3296	-63.49	-13	-50.49	-75.56	-66.9	1.54	7.10	H
	1648	-54.14	-13	-41.14	-57.41	-55.9	0.98	4.89	V
	2472	-31.72	-13	-18.72	-41.86	-33.6	1.28	5.32	V
	3296	-64.69	-13	-51.69	-75.87	-68.1	1.54	7.10	V
Middle	1672	-49.42	-13	-36.42	-55.76	-51.1	0.99	4.82	H
	2512	-34.13	-13	-21.13	-43.53	-36.1	1.29	5.41	H
	3345	-64.09	-13	-51.09	-76.15	-67.7	1.56	7.32	H
	1672	-55.92	-13	-42.92	-58.76	-57.6	0.99	4.82	V
	2509	-30.14	-13	-17.14	-40.24	-32.1	1.29	5.41	V
	3345	-64.59	-13	-51.59	-75.8	-68.2	1.56	7.32	V
	5856	-56.84	-13	-43.84	-76.54	-61.7	2.83	9.84	V
Highest	1696	-52.40	-13	-39.40	-57.16	-54	1.00	4.75	H
	2544	-37.22	-13	-24.22	-46.57	-39.2	1.30	5.44	H
	3393	-63.99	-13	-50.99	-76.12	-67.8	1.57	7.53	H
	1696	-55.50	-13	-42.50	-59.15	-57.1	1.00	4.75	V
	2544	-33.92	-13	-20.92	-44.04	-35.9	1.30	5.44	V
	3393	-64.69	-13	-51.69	-76.04	-68.5	1.57	7.53	V

Remark: Spurious emissions within 30-1000MHz were found more than 20dB below limit line.



GSM1900 (GPRS class 8)									
Channel	Frequency (MHz)	EIRP (dBm)	Limit (dBm)	Over Limit (dB)	SPA Reading (dBm)	S.G. Power (dBm)	TX Cable loss (dB)	TX Antenna Gain (dBi)	Polarization (H/V)
Lowest	3700	-55.03	-13	-42.03	-69.3	-61.6	1.67	8.24	H
	5548	-45.73	-13	-32.73	-65.69	-52.8	2.65	9.72	H
	7403	-51.75	-13	-38.75	-77.02	-60.9	2.46	11.61	H
	3700	-58.63	-13	-45.63	-72.91	-65.2	1.67	8.24	V
	5548	-45.51	-13	-32.51	-63.8	-52.58	2.65	9.72	V
	7403	-50.05	-13	-37.05	-74.23	-59.2	2.46	11.61	V
	9251	-50.14	-13	-37.14	-75.87	-60.2	2.54	12.60	V
Middle	3763	-57.57	-13	-44.57	-72.15	-64.2	1.69	8.32	H
	5639	-51.15	-13	-38.15	-70.9	-58.2	2.71	9.76	H
	7520	-53.71	-13	-40.71	-78.2	-63.1	2.42	11.81	H
	3763	-56.47	-13	-43.47	-70.57	-63.1	1.69	8.32	V
	5639	-49.05	-13	-36.05	-67.28	-56.1	2.71	9.76	V
	7522	-52.11	-13	-39.11	-76.16	-61.5	2.42	11.81	V
	9398	-51.73	-13	-38.73	-77.12	-61.7	2.57	12.54	V
Highest	3819	-55.72	-13	-42.72	-70.43	-62.4	1.70	8.38	H
	5730	-45.87	-13	-32.87	-65.68	-52.9	2.76	9.79	H
	7641	-54.10	-13	-41.10	-78.68	-63.6	2.38	11.88	H
	3819	-55.42	-13	-42.42	-69.29	-62.1	1.70	8.38	V
	5730	-48.67	-13	-35.67	-66.98	-55.7	2.76	9.79	V
	7641	-49.80	-13	-36.80	-73.56	-59.3	2.38	11.88	V

Remark: Spurious emissions within 30-1000MHz were found more than 20dB below limit line.



Appendix C. Test Setup Photographs