



FCC RF Test Report

APPLICANT : ASUSTeK COMPUTER INC.
EQUIPMENT : ASUS Phone
BRAND NAME : ASUS
MODEL NAME : ASUS_Z012DC
FCC ID : MSQZ012DC
STANDARD : FCC Part 15 Subpart E §15.407
CLASSIFICATION : (NII) Unlicensed National Information Infrastructure

The product was received on Apr. 01, 2016 and testing was completed on May 16, 2016. We, SPORTON INTERNATIONAL INC., would like to declare that the tested sample has been evaluated in accordance with the test procedures and has been in compliance with the applicable technical standards.

The test results in this report apply exclusively to the tested model / sample. Without written approval of SPORTON INTERNATIONAL INC., the test report shall not be reproduced except in full.

Reviewed by: Joseph Lin / Supervisor

Approved by: Jones Tsai / Manager



SPORTON INTERNATIONAL INC.

No. 52, Hwa Ya 1st Rd., Hwa Ya Technology Park, Kwei-Shan District, Tao Yuan City, Taiwan, R.O.C.



TABLE OF CONTENTS

REVISION HISTORY 3

SUMMARY OF TEST RESULT 4

1 GENERAL DESCRIPTION 5

 1.1 Applicant 5

 1.2 Manufacturer 5

 1.3 Product Feature of Equipment Under Test 5

 1.4 Product Specification of Equipment Under Test 6

 1.5 Modification of EUT 6

 1.6 Testing Location 7

 1.7 Applicable Standards 7

2 TEST CONFIGURATION OF EQUIPMENT UNDER TEST 8

 2.1 Carrier Frequency and Channel 8

 2.2 Pre-Scanned RF Power 9

 2.3 Test Mode 10

 2.4 Connection Diagram of Test System 11

 2.5 Support Unit used in test configuration and system 12

 2.6 EUT Operation Test Setup 12

 2.7 Measurement Results Explanation Example 12

3 TEST RESULT 13

 3.1 6dB and 26dB and 99% Occupied Bandwidth Measurement 13

 3.2 Maximum Conducted Output Power Measurement 16

 3.3 Power Spectral Density Measurement 17

 3.4 Unwanted Emissions Measurement 20

 3.5 AC Conducted Emission Measurement 25

 3.6 Frequency Stability Measurement 29

 3.7 Automatically Discontinue Transmission 30

 3.8 Antenna Requirements 31

4 LIST OF MEASURING EQUIPMENT 32

5 UNCERTAINTY OF EVALUATION 33

APPENDIX A. CONDUCTED TEST RESULTS

APPENDIX B. RADIATED SPURIOUS EMISSION

APPENDIX C. RADIATED SPURIOUS EMISSION PLOTS

APPENDIX D. DUTY CYCLE PLOTS

APPENDIX E. SETUP PHOTOGRAPHS



SUMMARY OF TEST RESULT

Report Section	FCC Rule	Description	Limit	Result	Remark
3.1	15.403(i)	6dB, 26dB and 99% Occupied Bandwidth	> 500kHz	Pass	-
3.2	15.407(a)	Maximum Conducted Output Power	≤ 30 dBm	Pass	-
3.3	15.407(a)	Power Spectral Density	≤ 30 dBm/500kHz	Pass	-
3.4	15.407(b)	Unwanted Emissions	15.407(b)(4)(i) ≤ -17, -27 dBm/MHz &15.209(a)	Pass	Under limit 4.93 dB at 38.100 MHz
3.5	15.207	AC Conducted Emission	15.207(a)	Pass	Under limit 11.00 dB at 0.518 MHz
3.6	15.407(g)	Frequency Stability	Within Operation Band	Pass	-
3.7	15.407(c)	Automatically Discontinue Transmission	Discontinue Transmission	Pass	-
3.8	15.203 & 15.407(a)	Antenna Requirement	N/A	Pass	-



1 General Description

1.1 Applicant

ASUSTeK COMPUTER INC.

4F, No. 150, LI-TE RD., PEITOU, TAIPEI, TAIWAN

1.2 Manufacturer

Cotek Electronics (Suzhou) Co., Ltd.

Jiangsu high tech Zone of Suzhou City, Ma Wan Road, No. 288

1.3 Product Feature of Equipment Under Test

Product Feature	
Equipment	ASUS Phone
Brand Name	ASUS
Model Name	ASUS_Z012DC
FCC ID	MSQZ012DC
EUT supports Radios application	GSM/EGPRS/WCDMA/HSPA/LTE WLAN 1b/g/n HT20 WLAN 11a/n HT20/HT40 WLAN 11ac VHT20/VHT40/VHT80 Bluetooth v4.0 EDR/LE
EUT Stage	Production Unit

Remark: The above EUT's information was declared by manufacturer. Please refer to the specifications or user's manual for more detailed description.



1.4 Product Specification of Equipment Under Test

Standards-related Product Specification	
Tx/Rx Channel Frequency Range	5745 MHz ~ 5825 MHz
Maximum Output Power	802.11a : 14.93 dBm / 0.0311 W 802.11n HT20 : 13.84 dBm / 0.0242 W 802.11n HT40 : 13.54 dBm / 0.0226 W 802.11ac VHT20: 10.73 dBm / 0.0118 W 802.11ac VHT40: 10.99 dBm / 0.0126 W 802.11ac VHT80: 10.77 dBm / 0.0119 W
99% Occupied Bandwidth	802.11a : 18.35 MHz 802.11n HT20 : 19.15 MHz 802.11n HT40 : 36.70 MHz 802.11ac VHT20 : 19.15 MHz 802.11ac VHT40 : 36.70 MHz 802.11ac VHT80 : 75.12 MHz
Type of Modulation	802.11a/n : OFDM (BPSK / QPSK / 16QAM / 64QAM) 802.11ac : OFDM (BPSK / QPSK / 16QAM / 64QAM / 256QAM)
Antenna Type	PIFA Antenna
Antenna Gain	-3.60 dBi

1.5 Modification of EUT

No modifications are made to the EUT during all test items.



1.6 Testing Location

Sporton Lab is accredited to ISO 17025 by Taiwan Accreditation Foundation (TAF code : 1190) and the FCC designation No. TW1022 under the FCC 2.948(e) by Mutual Recognition Agreement (MRA) in FCC Test.

Test Site	SPORTON INTERNATIONAL INC.	
Test Site Location	No. 52, Hwa Ya 1 st Rd., Hwa Ya Technology Park, Kwei-Shan District, Tao Yuan City, Taiwan, R.O.C. TEL: +886-3-327-3456 FAX: +886-3-328-4978	
Test Site No.	Sporton Site No.	
	TH02-HY	CO05-HY

Note: The test site complies with ANSI C63.4 2014 requirement.

Test Site	SPORTON INTERNATIONAL INC.	
Test Site Location	No.58, Aly. 75, Ln. 564, Wenhua 3rd Rd. Guishan Dist, Taoyuan City, Taiwan (R.O.C.) TEL: +886-3-327-0868 FAX: +886-3-327-0855	
Test Site No.	Sporton Site No.	
	03CH11-HY	

Note: The test site complies with ANSI C63.4 2014 requirement.

1.7 Applicable Standards

According to the specifications of the manufacturer, the EUT must comply with the requirements of the following standards:

- ♦ FCC Part 15 Subpart E
- ♦ FCC KDB 789033 D02 General UNII Test Procedures New Rules v01r02
- ♦ ANSI C63.10-2013

Remark:

1. All test items were verified and recorded according to the standards and without any deviation during the test.
2. This EUT has also been tested and complied with the requirements of FCC Part 15, Subpart B, recorded in a separate test report.



2 Test Configuration of Equipment Under Test

The EUT has been associated with peripherals and configuration operated in a manner tended to maximize its emission characteristics in a typical application. Frequency range investigated: conducted emission (150 kHz to 30 MHz) and radiated emission (9 kHz to the 10th harmonic of the highest fundamental frequency or to 40 GHz, whichever is lower). For radiated measurement, pre-scanned in three orthogonal panels, X, Y, Z. The worst cases (X plane) were recorded in this report.

The final configuration from all the combinations and the worst-case data rates were investigated by measuring the maximum power across all the data rates and modulation modes under section 2.2.

Based on the worst configuration found above, the RF power setting is set individually to meet FCC compliance limit for the final conducted and radiated tests shown in section 2.3.

2.1 Carrier Frequency and Channel

Frequency Band	Channel	Freq. (MHz)	Channel	Freq. (MHz)
5725-5850 MHz Band 4 (U-NII-3)	149	5745	157	5785
	151	5755	159	5795
	153	5765	161	5805
	155	5775	165	5825

Note: The above Frequency and Channel in boldface were 802.11n HT40.



2.2 Pre-Scanned RF Power

Preliminary tests were performed in different data rate and data rate associated with the highest power were chosen for full test in the following tables. Final Output Power equals to Measured Output Power adds the duty factor.

5GHz 802.11a mode								
Data Rate (MHz)	6M bps	9M bps	12M bps	18M bps	24M bps	36M bps	48M bps	54M bps
Average Power (dBm)	14.93	14.67	14.60	14.71	14.69	14.66	14.57	14.80

5GHz 802.11n HT20 mode								
Data Rate (MHz)	MCS0	MCS1	MCS2	MCS3	MCS4	MCS5	MCS6	MCS7
Average Power (dBm)	13.84	13.58	13.68	13.55	13.61	13.51	13.82	13.64

5GHz 802.11n HT40 mode								
Data Rate (MHz)	MCS0	MCS1	MCS2	MCS3	MCS4	MCS5	MCS6	MCS7
Average Power (dBm)	13.54	13.52	13.43	13.52	13.38	13.37	13.44	13.38

5GHz 802.11ac VHT20 mode									
Data Rate (MHz)	MCS 0	MCS 1	MCS 2	MCS 3	MCS 4	MCS 5	MCS 6	MCS 7	MCS 8
Average Power (dBm)	10.73	10.50	10.51	10.52	10.47	10.44	10.58	10.43	10.44

5GHz 802.11ac VHT40 mode										
Data Rate (MHz)	MCS 0	MCS 1	MCS 2	MCS 3	MCS 4	MCS 5	MCS 6	MCS 7	MCS 8	MCS 9
Average Power (dBm)	10.99	10.95	10.96	10.88	10.98	10.96	10.79	10.86	10.76	10.83

5GHz 802.11ac VHT80 mode										
Data Rate (MHz)	MCS 0	MCS 1	MCS 2	MCS 3	MCS 4	MCS 5	MCS 6	MCS 7	MCS 8	MCS 9
Average Power (dBm)	10.77	10.59	10.64	10.64	10.56	10.53	10.46	10.52	10.55	10.63



2.3 Test Mode

Final test mode of conducted test items and radiated spurious emissions are considering the modulation and worse data rates from the power table described in section 2.2.

Modulation	Data Rate
802.11a	6 Mbps
802.11n HT20	MCS0
802.11n HT40	MCS0
802.11ac VHT20	MCS0
802.11ac VHT40	MCS0
802.11ac VHT80	MCS0

Test Cases	
AC Conducted Emission	Mode 1 : GSM1900 Idle + Bluetooth Link + WLAN (5GHz) Link + GPS Rx + USB Cable 1 (Charging from Adapter 2) + Earphone + SD Card (Play MP3) + SIM 1

Ch. #		Band IV : 5725-5850 MHz		
		802.11a	802.11n HT20	802.11n HT40
L	Low	149	149	151
M	Middle	157	157	-
H	High	165	165	159

Ch. #		Band IV : 5725-5850 MHz		
		802.11ac VHT20	802.11ac VHT40	802.11ac VHT80
L	Low	149	151	-
M	Middle	157	-	155
H	High	165	159	-

2.4 Connection Diagram of Test System

<WLAN Tx Mode>

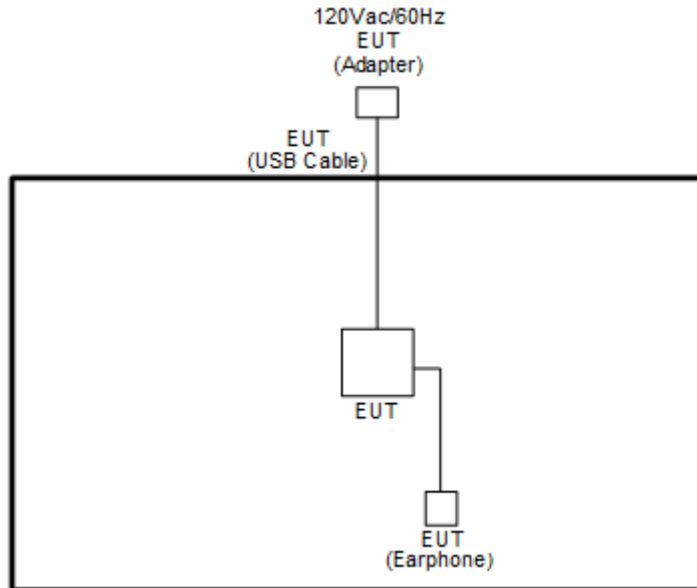

<AC Conducted Emission Mode>

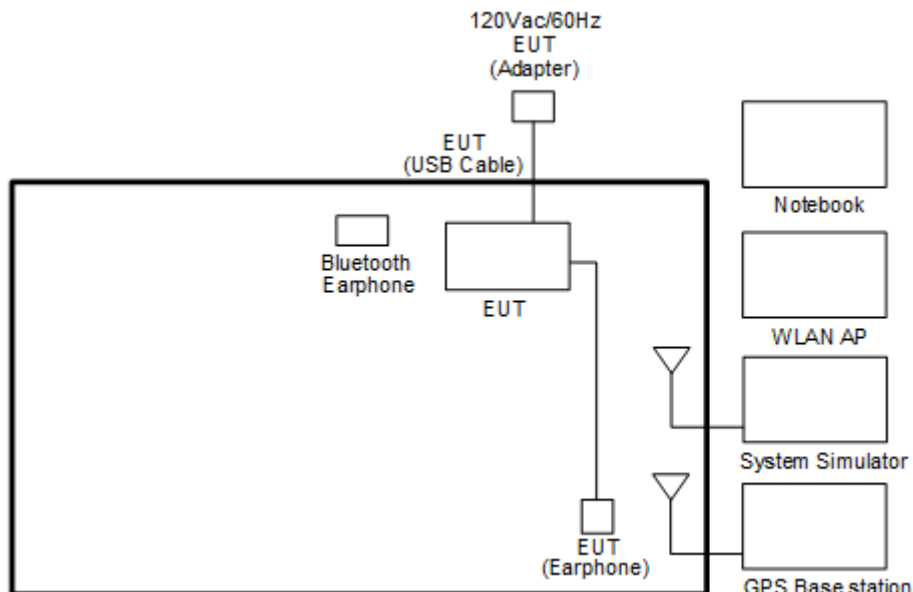



2.5 Support Unit used in test configuration and system

Item	Equipment	Trade Name	Model Name	FCC ID	Data Cable	Power Cord
1.	System Simulator	Anritsu	MT8820C	N/A	N/A	Unshielded, 1.8 m
2.	GPS Station	Pendulum	GSG-54	N/A	N/A	Unshielded, 1.8 m
3.	Bluetooth Earphone	Sony Ericsson	MW600	PY7DDA-2029	N/A	N/A
4.	WLAN AP	ASUS	RT-AC66U	FCC DoC	N/A	N/A
5.	Notebook	DELL	Latitude E6320	FCC DoC/ Contains FCC ID: QDS-BRCM1054	N/A	AC I/P: Unshielded, 1.2 m DC O/P: Shielded, 1.8 m
6.	SD Card	SanDisk	MicroSD HC	FCC DoC	N/A	N/A

2.6 EUT Operation Test Setup

For WLAN function, programmed RF utility, "Wifi_BTTest app" installed in the EUT provide functions like channel selection and power level for continuous transmitting and receiving signals.

2.7 Measurement Results Explanation Example

For all conducted test items:

The offset level is set in the spectrum analyzer to compensate the RF cable loss and attenuator factor between EUT conducted output port and spectrum analyzer. With the offset compensation, the spectrum analyzer reading level is exactly the EUT RF output level.

Example :

The spectrum analyzer offset is derived from RF cable loss and attenuator factor.

Offset = RF cable loss + attenuator factor.

Following shows an offset computation example with cable loss 4.2 dB and 10dB attenuator.

$$\begin{aligned} \text{Offset(dB)} &= \text{RF cable loss(dB)} + \text{attenuator factor(dB)}. \\ &= 4.2 + 10 = 14.2 \text{ (dB)} \end{aligned}$$

3 Test Result

3.1 6dB and 26dB and 99% Occupied Bandwidth Measurement

3.1.1 Description of 6dB and 26dB and 99% Occupied Bandwidth

The minimum 6 dB bandwidth shall be at least 500 kHz.

26dB and 99% Occupied bandwidth are reporting only.

3.1.2 Measuring Instruments

The measuring equipment is listed in the section 4 of this test report.

3.1.3 Test Procedures

1. The testing follows FCC KDB 789033 D02 General UNII Test Procedures New Rules v01r02.
Section C) Emission bandwidth for the band 5.725-5.85GHz
2. Set RBW = 100kHz.
3. Set the VBW $\geq 3 \times$ RBW.
4. Detector = Peak.
5. Trace mode = max hold
6. Measure the maximum width of the emission that is 6 dB down from the peak of the emission.
7. Measure and record the results in the test report.

3.1.4 Test Setup





3.1.5 Test Result of 6dB Bandwidth

Please refer to Appendix A.

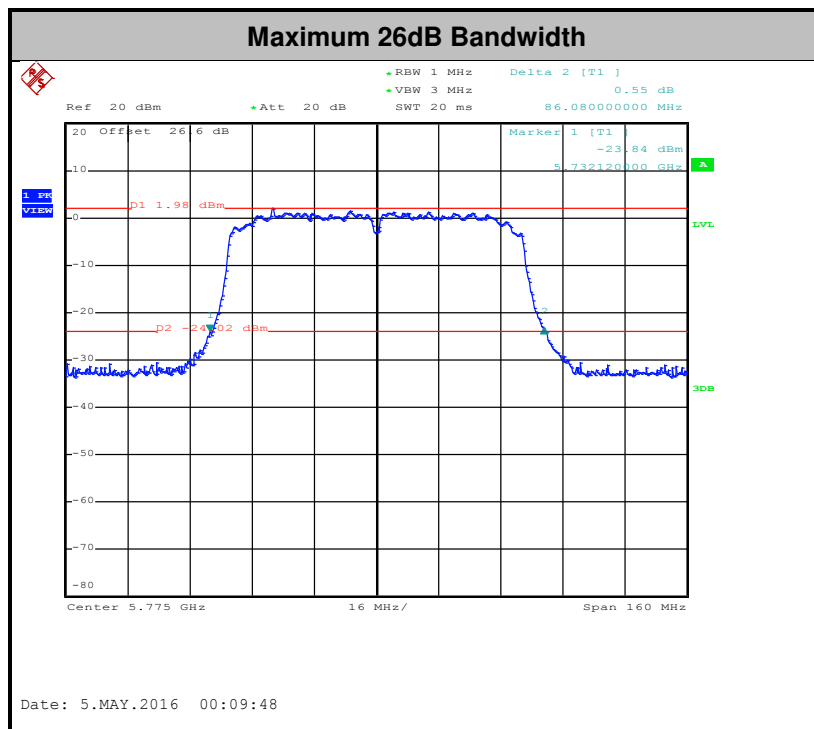
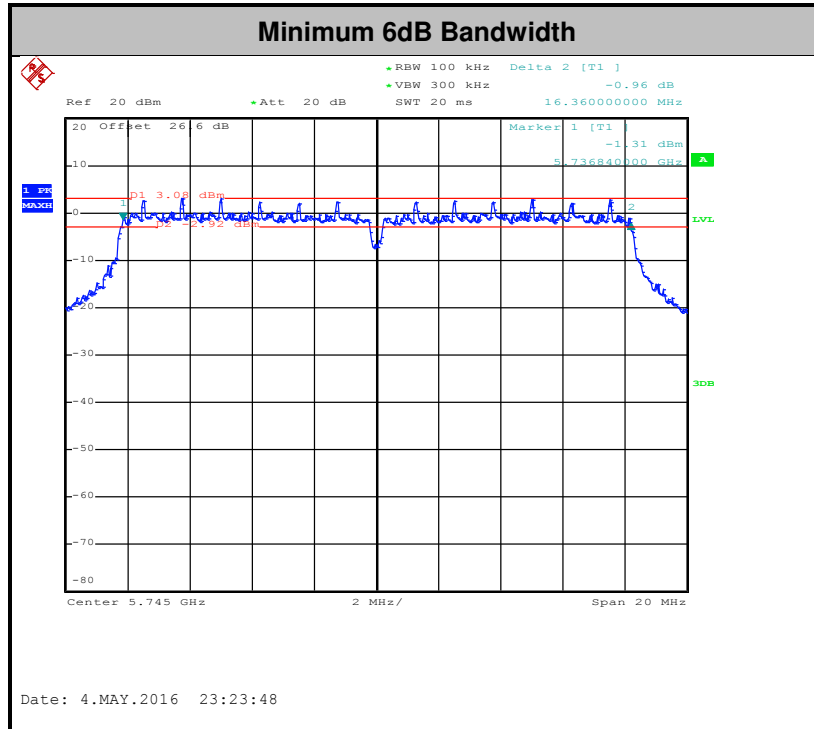

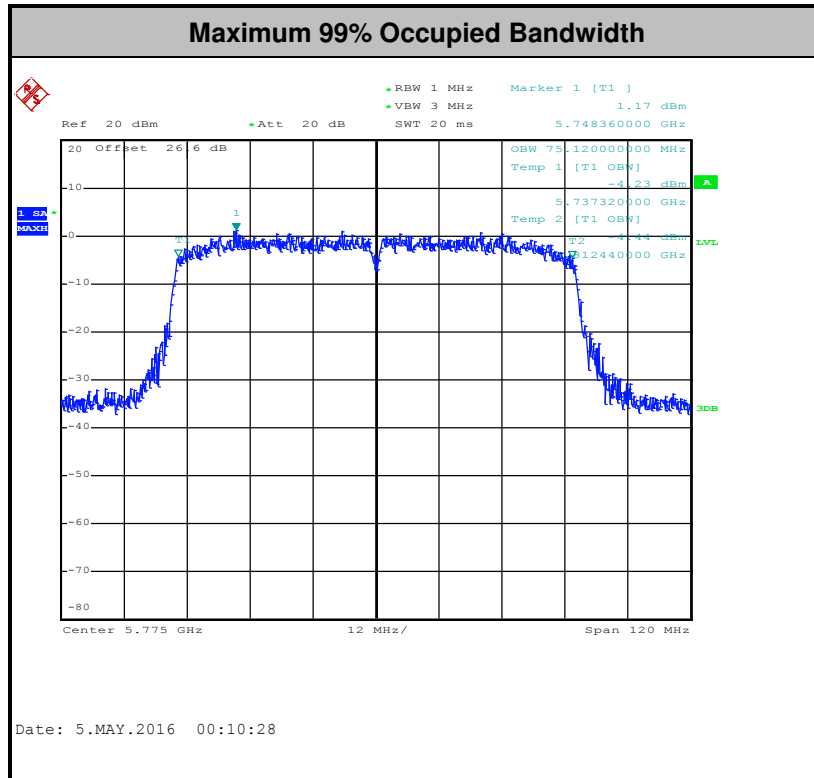

Note: The occupied channel bandwidth is maintained within the band of operation for all of the modulations.

3.2 Maximum Conducted Output Power Measurement

3.2.1 Limit of Maximum Conducted Output Power

For the band 5.725–5.85 GHz, the maximum conducted output power over the frequency band of operation shall not exceed 1 W.

If transmitting antennas of directional gain greater than 6 dBi are used, the peak output power shall be reduced by the amount in dB that the directional gain of the antenna exceeds 6 dBi.

3.2.2 Measuring Instruments

The measuring equipment is listed in the section 4 of this test report.

3.2.3 Test Procedures

The testing follows Method PM of FCC KDB 789033 D02 General UNII Test Procedures New Rules v01r02.

Method PM (Measurement using an RF average power meter):

1. Measurement is performed using a wideband RF power meter.
2. The EUT is configured to transmit continuously with a consistent duty cycle at its maximum power control level.
3. Measure the average power of the transmitter, and the average power is corrected with duty factor, $10 \log(1/x)$, where x is the duty cycle.

3.2.4 Test Setup

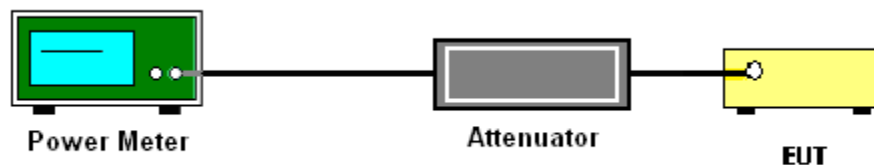

3.2.5 Test Result of Maximum Conducted Output Power

Please refer to Appendix A.



3.3 Power Spectral Density Measurement

3.3.1 Limit of Power Spectral Density

For the band 5.725–5.85 GHz, the maximum power spectral density shall not exceed 30 dBm in any 500-kHz band.

If transmitting antennas of directional gain greater than 6 dBi are used, the peak output power shall be reduced by the amount in dB that the directional gain of the antenna exceeds 6 dBi.

3.3.2 Measuring Instruments

The measuring equipment is listed in the section 4 of this test report.

3.3.3 Test Procedures

The testing follows FCC KDB 789033 D02 General UNII Test Procedures New Rules v01r02. Section F) Maximum power spectral density.

Method SA-2

(trace averaging across on and off times of the EUT transmissions, followed by duty cycle correction).

1. The testing follows Method SA-2 of FCC KDB 789033 D02 General UNII Test Procedures New Rules v01r02.
 - Measure the duty cycle.
 - Set span to encompass the entire emission bandwidth (EBW) of the signal.
 - Set RBW = 300 kHz.
 - Set VBW \geq 1 MHz.
 - Number of points in sweep \geq 2 Span / RBW.
 - Sweep time = auto.
 - Detector = RMS
 - Trace average at least 100 traces in power averaging mode.
 - Add $10 \log(500\text{kHz}/\text{RBW})$ to the test result.
 - Add $10 \log(1/x)$, where x is the duty cycle, to the measured power in order to compute the average power during the actual transmission times. For example, add $10 \log(1/0.25) = 6$ dB if the duty cycle is 25 percent.

2. The RF output of EUT was connected to the spectrum analyzer by a low loss cable.
3. Each plot has already offset with cable loss, and attenuator loss. Measure the PPSD and record it.

3.3.4 Test Setup

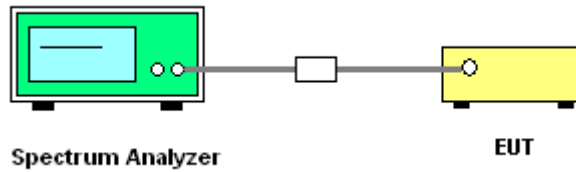



3.3.5 Test Result of Power Spectral Density

Please refer to Appendix A.

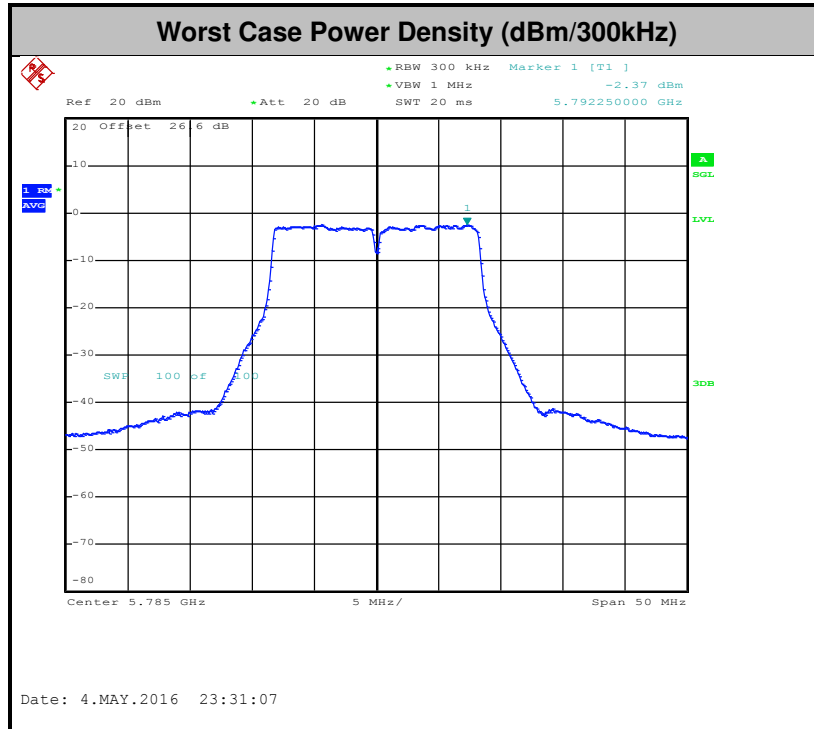



3.4 Unwanted Emissions Measurement

This section as specified in FCC Part 15.407(b) is to measure unwanted emissions through radiated measurement for band edge spurious emissions and out of band emissions measurement. The unwanted emissions shall comply with 15.407(b)(1) to (6), and restricted bands per FCC Part15.205.

3.4.1 Limit of Unwanted Emissions

- (1) For transmitters operating in the 5.725-5.85 GHz band:
15.407(b)(4)(i) All emissions shall be limited to a level of -27 dBm/MHz at 75 MHz or more above or below the band edge increasing linearly to 10 dBm/MHz at 25 MHz above or below the band edge, and from 25 MHz above or below the band edge increasing linearly to a level of 15.6 dBm/MHz at 5 MHz above or below the band edge, and from 5 MHz above or below the band edge increasing linearly to a level of 27 dBm/MHz at the band edge.
- (2) Unwanted spurious emissions fallen in restricted bands per FCC Part15.205 shall comply with the general field strength limits set forth in § 15.209 as below table,

Frequency (MHz)	Field Strength (microvolts/meter)	Measurement Distance (meters)
0.009 – 0.490	2400/F(kHz)	300
0.490 – 1.705	24000/F(kHz)	30
1.705 – 30.0	30	30
30 – 88	100	3
88 – 216	150	3
216 - 960	200	3
Above 960	500	3

Note: The following formula is used to convert the EIRP to field strength.

$$E = \frac{1000000\sqrt{30P}}{3} \text{ } \mu\text{V/m, where P is the eirp (Watts)}$$

EIRP (dBm)	Field Strength at 3m (dBμV/m)
-17	78.3
-27	68.3

- (3) KDB 789033 D02 General UNII Test Procedures New Rules v01r02 G)2)c) As specified in 15.407(b), emissions above 1000 MHz that are outside of the restricted bands are subject to a peak emission limit of -27 dBm/MHz (or -17 dBm/MHz as specified in 15.407(b)(4)). However, an out-of-band emission that complies with both the average and peak limits of 15.209 is not required to satisfy the -27 dBm/MHz or -17 dBm/MHz peak emission limit.



3.4.2 Measuring Instruments

The measuring equipment is listed in the section 4 of this test report.

3.4.3 Test Procedures

1. The testing follows FCC KDB 789033 D02 General UNII Test Procedures New Rules v01r02. Section G) Unwanted emissions measurement.

(1) Procedure for Unwanted Emissions Measurements Below 1000MHz

- RBW = 120 kHz
- VBW = 300 kHz
- Detector = Peak
- Trace mode = max hold

(2) Procedure for Peak Unwanted Emissions Measurements Above 1000 MHz

- RBW = 1 MHz
- VBW \geq 3 MHz
- Detector = Peak
- Sweep time = auto
- Trace mode = max hold

(3) Procedures for Average Unwanted Emissions Measurements Above 1000MHz

- RBW = 1 MHz
- VBW = 10 Hz, when duty cycle is no less than 98 percent.
- VBW \geq 1/T, when duty cycle is less than 98 percent where T is the minimum transmission duration over which the transmitter is on and is transmitting at its maximum power control level for the tested mode of operation.



2. The EUT was placed on a turntable with 0.8 meter for frequency below 1GHz and 1.5 meter for frequency above 1GHz respectively above ground.
3. The EUT was set 3 meters from the interference receiving antenna which was mounted on the top of a variable height antenna tower.
4. The antenna is a broadband antenna and its height is adjusted between one meter and four meters above ground to find the maximum value of the field strength for both horizontal polarization and vertical polarization of the antenna.
5. For each suspected emission, the EUT was arranged to its worst case and then adjust the antenna tower (from 1 m to 4 m) and turntable (from 0 degree to 360 degrees) to find the maximum reading.
6. For testing below 1GHz, if the emission level of the EUT in peak mode was 3 dB lower than the limit specified, then peak values of EUT will be reported, otherwise, the emissions will be repeated one by one using the CISPR quasi-peak method and reported.
7. For testing above 1GHz, the emission level of the EUT in peak mode was 20dB lower than average limit (that means the emission level in average mode also complies with the limit in average mode), then peak values of EUT will be reported, otherwise, the emissions will be measured in average mode again and reported.

3.4.4 Test Setup

For radiated emissions below 30MHz

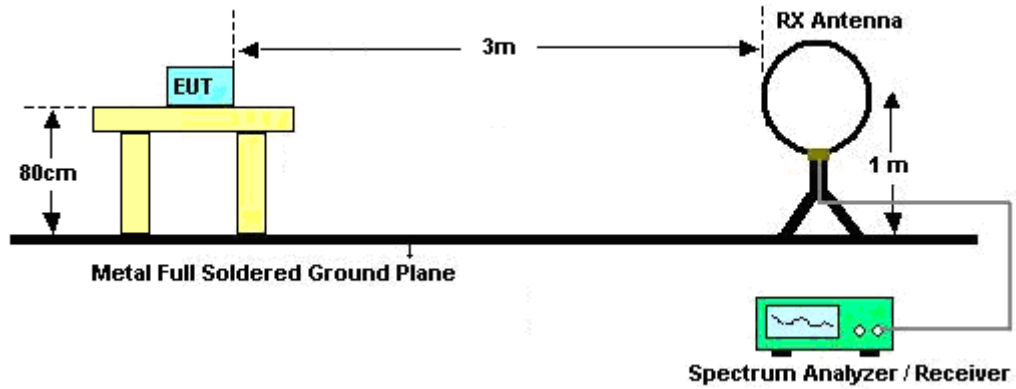

For radiated emissions from 30MHz to 1GHz

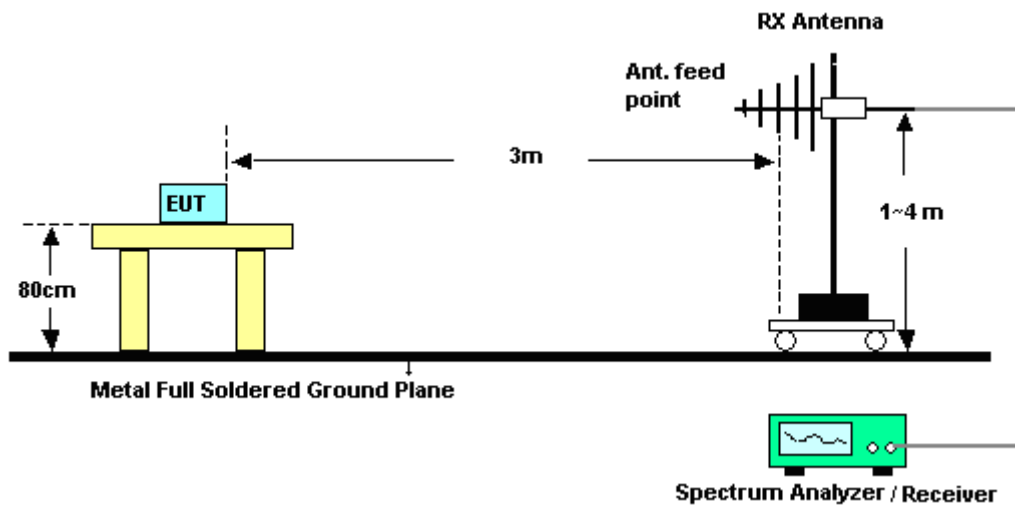

For radiated emissions above 1GHz

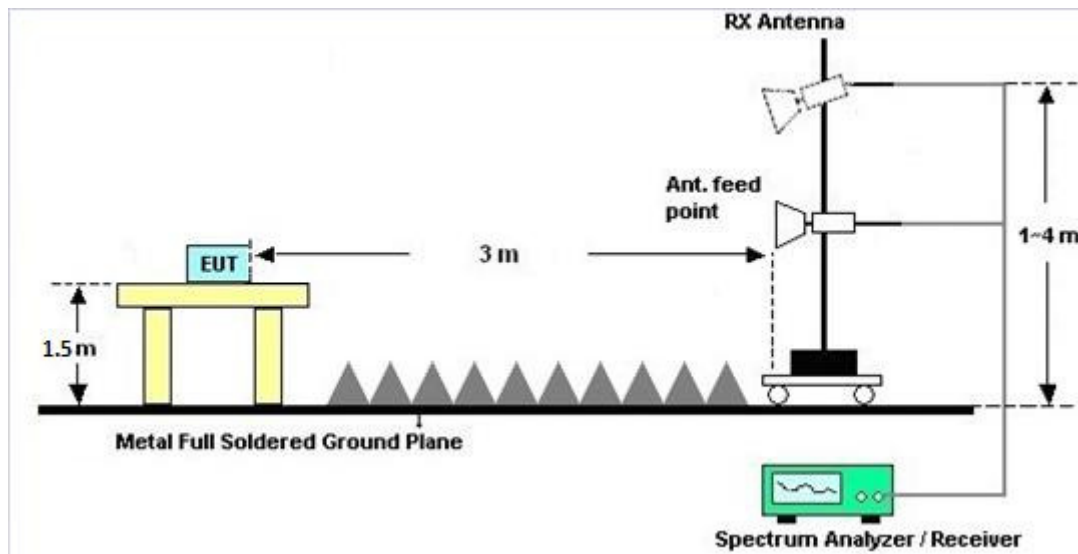

3.4.5 Test Results of Radiated Emissions (9 kHz ~ 30 MHz)

The low frequency, which started from 9 kHz to 30MHz, was pre-scanned and the result which was 20dB lower than the limit line per 15.31(o) was not reported.

3.4.6 Test Result of Radiated Band Edges

Please refer to Appendix B and C.

3.4.7 Duty Cycle

Please refer to Appendix D.

3.4.8 Test Result of Unwanted Radiated Emission (30MHz ~ 10th Harmonic)

Please refer to Appendix B and C.



3.5 AC Conducted Emission Measurement

3.5.1 Limit of AC Conducted Emission

For equipment that is designed to be connected to the public utility (AC) power line, the radio frequency voltage that is conducted back onto the AC power line on any frequency or frequencies within the band 150 kHz to 30 MHz shall not exceed the limits in the following table.

Frequency of emission (MHz)	Conducted limit (dB μ V)	
	Quasi-peak	Average
0.15-0.5	66 to 56*	56 to 46*
0.5-5	56	46
5-30	60	50

*Decreases with the logarithm of the frequency.

3.5.2 Measuring Instruments

The measuring equipment is listed in the section 4 of this test report.

3.5.3 Test Procedures

1. The EUT was placed 0.4 meter from the conducting wall of the shielding room was kept at least 80 centimeters from any other grounded conducting surface.
2. Connect EUT to the power mains through a line impedance stabilization network (LISN).
3. All the support units are connecting to the other LISN.
4. The LISN provides 50 ohm coupling impedance for the measuring instrument.
5. The FCC states that a 50 ohm, 50 microhenry LISN should be used.
6. Both sides of AC line were checked for maximum conducted interference.
7. The frequency range from 150 kHz to 30 MHz was searched.
8. Set the test-receiver system to Peak Detect Function and specified bandwidth with Maximum Hold Mode.

3.5.4 Test Setup

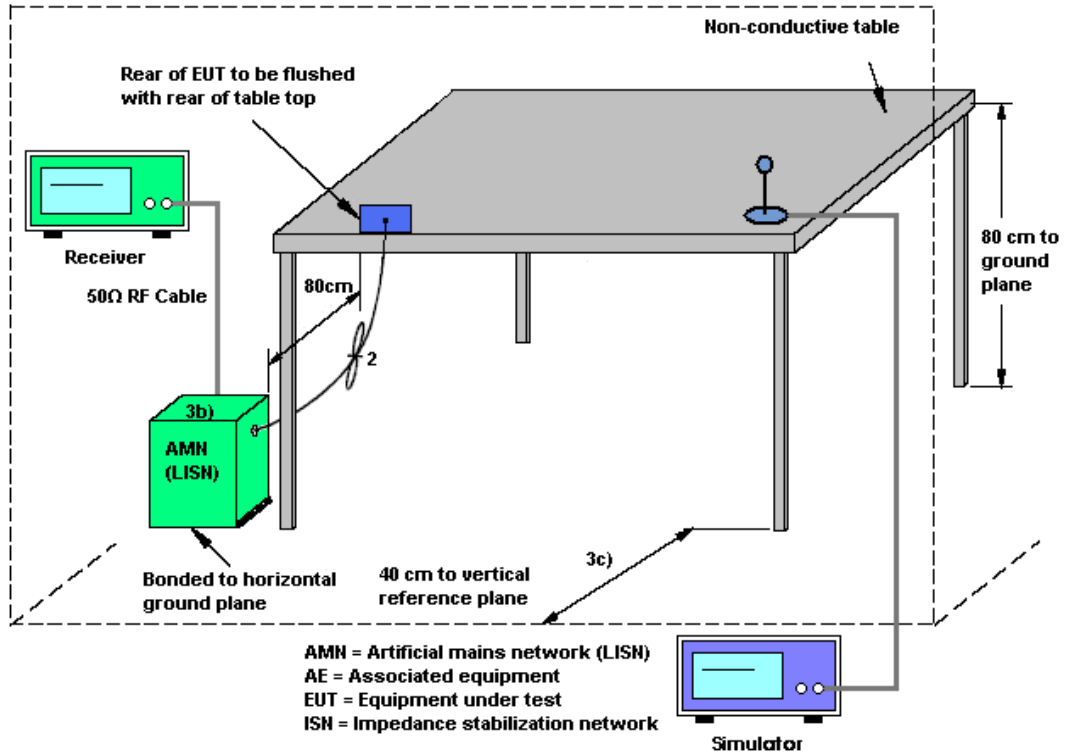



3.5.5 Test Result of AC Conducted Emission

Test Mode :	Mode 1	Temperature :	24~25°C
Test Engineer :	Kai-Chun Chu	Relative Humidity :	44~45%
Test Voltage :	120Vac / 60Hz	Phase :	Line
Function Type :	GSM1900 Idle + Bluetooth Link + WLAN (5GHz) Link + GPS Rx + USB Cable 1 (Charging from Adapter 2) + Earphone + SD Card (Play MP3) + SIM 1		

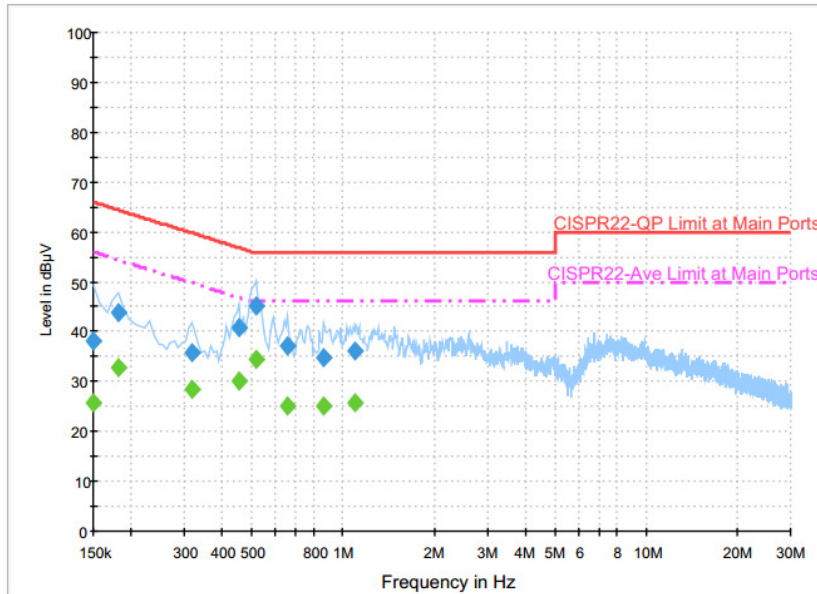

Final Result : QuasiPeak

Frequency (MHz)	QuasiPeak (dBµV)	Filter	Line	Corr. (dB)	Margin (dB)	Limit (dBµV)
0.150000	38.2	Off	L1	19.6	27.8	66.0
0.182000	43.8	Off	L1	19.6	20.6	64.4
0.318000	35.8	Off	L1	19.6	24.0	59.8
0.454000	40.9	Off	L1	19.6	15.9	56.8
0.518000	45.0	Off	L1	19.6	11.0	56.0
0.654000	37.3	Off	L1	19.6	18.7	56.0
0.862000	34.8	Off	L1	19.6	21.2	56.0
1.102000	36.2	Off	L1	19.7	19.8	56.0

Final Result : Average

Frequency (MHz)	Average (dBµV)	Filter	Line	Corr. (dB)	Margin (dB)	Limit (dBµV)
0.150000	25.7	Off	L1	19.6	30.3	56.0
0.182000	32.7	Off	L1	19.6	21.7	54.4
0.318000	28.4	Off	L1	19.6	21.4	49.8
0.454000	30.1	Off	L1	19.6	16.7	46.8
0.518000	34.6	Off	L1	19.6	11.4	46.0
0.654000	25.1	Off	L1	19.6	20.9	46.0
0.862000	25.1	Off	L1	19.6	20.9	46.0
1.102000	25.9	Off	L1	19.7	20.1	46.0



Test Mode :	Mode 1	Temperature :	24~25°C
Test Engineer :	Kai-Chun Chu	Relative Humidity :	44~45%
Test Voltage :	120Vac / 60Hz	Phase :	Neutral
Function Type :	GSM1900 Idle + Bluetooth Link + WLAN (5GHz) Link + GPS Rx + USB Cable 1 (Charging from Adapter 2) + Earphone + SD Card (Play MP3) + SIM 1		

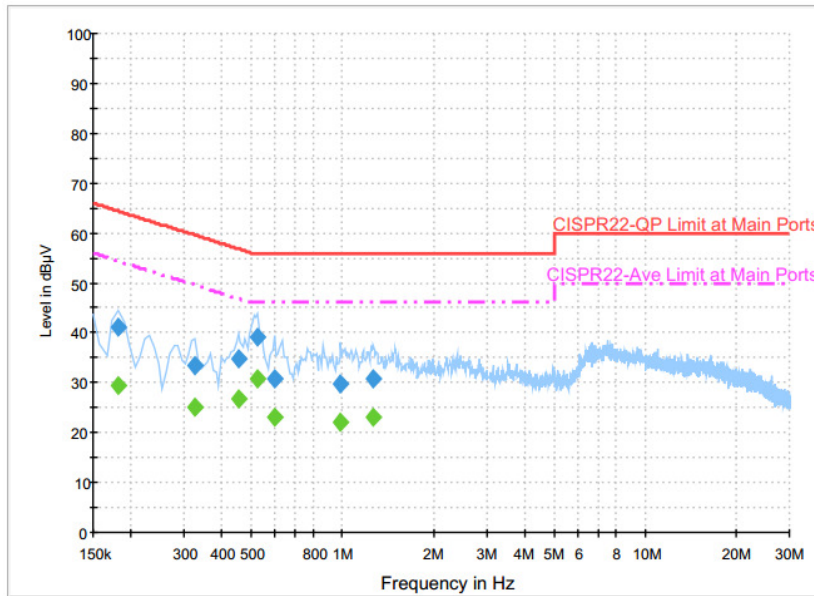

Final Result : QuasiPeak

Frequency (MHz)	QuasiPeak (dBµV)	Filter	Line	Corr. (dB)	Margin (dB)	Limit (dBµV)
0.182000	41.2	Off	N	19.6	23.2	64.4
0.326000	33.5	Off	N	19.6	26.1	59.6
0.454000	34.8	Off	N	19.6	22.0	56.8
0.526000	39.1	Off	N	19.6	16.9	56.0
0.598000	30.9	Off	N	19.6	25.1	56.0
0.990000	29.9	Off	N	19.6	26.1	56.0
1.270000	30.9	Off	N	19.6	25.1	56.0

Final Result : Average

Frequency (MHz)	Average (dBµV)	Filter	Line	Corr. (dB)	Margin (dB)	Limit (dBµV)
0.182000	29.3	Off	N	19.6	25.1	54.4
0.326000	25.1	Off	N	19.6	24.5	49.6
0.454000	26.7	Off	N	19.6	20.1	46.8
0.526000	30.9	Off	N	19.6	15.1	46.0
0.598000	23.2	Off	N	19.6	22.8	46.0
0.990000	22.1	Off	N	19.6	23.9	46.0
1.270000	23.2	Off	N	19.6	22.8	46.0

3.6 Frequency Stability Measurement

3.6.1 Limit of Frequency Stability

Manufacturers of U-NII devices are responsible for ensuring frequency stability such that an emission is maintained within the band of operation under all conditions of normal operation as specified in the user's manual.

3.6.2 Measuring Instruments

The measuring equipment is listed in the section 4 of this test report.

3.6.3 Test Procedures

1. To ensure emission at the band edge is maintained within the authorized band, those values shall be measured by radiation emissions at upper and lower frequency points, and finally compensated by frequency deviation as procedures below.
2. The EUT was operated at the maximum output power, and connected to the spectrum analyzer, which is set to maximum hold function and peak detector. The peak value of the power envelope was measured and noted. The upper and lower frequency points were respectively measured relatively 10dB lower than the measured peak value.
3. The frequency deviation was calculated by adding the upper frequency point and the lower frequency point divided by two. Those detailed values of frequency deviation are provided in table below.

3.6.4 Test Setup



3.6.5 Test Result of Frequency Stability

Please refer to Appendix A.



3.7 Automatically Discontinue Transmission

3.7.1 Limit of Automatically Discontinue Transmission

The device shall automatically discontinue transmission in case of either absence of information to transmit or operational failure. These provisions are not intended to preclude the transmission of control or signaling information or the use of repetitive codes used by certain digital technologies to complete frame or burst intervals. Applicants shall include in their application for equipment authorization to describe how this requirement is met.

3.7.2 Measuring Instruments

The measuring equipment is listed in the section 4 of this test report.

3.7.3 Test Result of Automatically Discontinue Transmission

While the EUT is not transmitting any information, the EUT can automatically discontinue transmission and become standby mode for power saving. The EUT can detect the controlling signal of ACK message transmitting from remote device and verify whether it shall resend or discontinue transmission.



3.8 Antenna Requirements

3.8.1 Standard Applicable

According to FCC 47 CFR Section 15.407(a)(1)(2) ,if transmitting antenna directional gain is greater than 6 dBi, both the peak transmit power and the peak power spectral density shall be reduced by the amount in dB that the directional gain of the antenna exceeds 6 dBi.

3.8.2 Antenna Anti-Replacement Construction

Non-standard antenna connector is used.

3.8.3 Antenna Gain

The antenna gain is less than 6 dBi. Therefore, it is not necessary to reduce maximum peak output power limit.



4 List of Measuring Equipment

Instrument	Manufacturer	Model No.	Serial No.	Characteristics	Calibration Date	Test Date	Due Date	Remark
Power Meter	Anritsu	ML2495A	1132003	300MHz~40GHz	Aug. 12, 2015	May 02, 2016 ~ May 08, 2016	Aug. 11, 2016	Conducted (TH05-HY)
Power Sensor	Anritsu	MA2411B	1126017	300MHz~40GHz	Aug. 12, 2015	May 02, 2016 ~ May 08, 2016	Aug. 11, 2016	Conducted (TH05-HY)
Spectrum Analyzer	Rohde & Schwarz	FSP40	100057	9kHz-40GHz	Nov. 23, 2015	May 02, 2016 ~ May 08, 2016	Nov. 22, 2016	Conducted (TH05-HY)
Temperature Chamber	ESPEC	SU-241	92003713	-30℃ ~95℃	Jun. 15, 2015	May 02, 2016 ~ May 08, 2016	Jun. 14, 2016	Conducted (TH05-HY)
Programmable Power Supply	GW Instek	PSS-2005	GEO821763	N/A	Nov. 13, 2015	May 02, 2016 ~ May 08, 2016	Nov. 12, 2016	Conducted (TH05-HY)
Loop Antenna	Rohde & Schwarz	HFH2-Z2	100315	9 kHz~30 MHz	Sep. 02, 2015	May 12, 2016 ~ May 16, 2016	Sep. 01, 2016	Radiation (03CH11-HY)
Amplifier	SONOMA	310N	187312	9kHz~1GHz	Nov. 20, 2015	May 12, 2016 ~ May 16, 2016	Nov. 19, 2016	Radiation (03CH11-HY)
Bilog Antenna	TESEQ	CBL 6111D	35414	30MHz~1GHz	Nov. 17, 2015	May 12, 2016 ~ May 16, 2016	Nov. 16, 2016	Radiation (03CH11-HY)
Horn Antenna	SCHWARZBECK	BBHA 9120 D	9120D-1326	1GHz ~ 18GHz	Oct. 08, 2015	May 12, 2016 ~ May 16, 2016	Oct. 07, 2016	Radiation (03CH11-HY)
Hygrometer	TECPEL	DTN-303B	TP140325	N/A	Nov. 17, 2015	May 12, 2016 ~ May 16, 2016	Nov. 16, 2016	Radiation (03CH11-HY)
Preamplifier	Keysight	83017A	MY53270080	1GHz~26.5GHz	Nov. 19, 2015	May 12, 2016 ~ May 16, 2016	Nov. 18, 2016	Radiation (03CH11-HY)
Preamplifier	MITEQ	AMF-7D-0010 1800-30-10P	1902247	1GHz~18GHz	Jul. 01, 2015	May 12, 2016 ~ May 16, 2016	Jun. 30, 2016	Radiation (03CH11-HY)
Spectrum Analyzer	Keysight	N9010A	MY54200486	10Hz ~ 44GHz	Sep. 24, 2015	May 12, 2016 ~ May 16, 2016	Sep. 23, 2016	Radiation (03CH11-HY)
Controller	EMEC	EM 1000	N/A	Control Turn table & Ant Mast	N/A	May 12, 2016 ~ May 16, 2016	N/A	Radiation (03CH11-HY)
Antenna Mast	EMEC	AM-BS-4500-B	N/A	1~4m	N/A	May 12, 2016 ~ May 16, 2016	N/A	Radiation (03CH11-HY)
Turn Table	EMEC	TT 2000	N/A	0~360 Degree	N/A	May 12, 2016 ~ May 16, 2016	N/A	Radiation (03CH11-HY)
SHF-EHF Horn Antenna	SCHWARZBECK	BBHA 9170	BBHA9170584	18GHz- 40GHz	Nov. 02, 2015	May 12, 2016 ~ May 16, 2016	Nov. 01, 2016	Radiation (03CH11-HY)
Preamplifier	MITEQ	JS44-1800400 0-33-8P	1840917	18GHz ~ 40GHz	Jun. 02, 2015	May 12, 2016 ~ May 16, 2016	Jun. 01, 2016	Radiation (03CH11-HY)
AC Power Source	ChainTek	APC-1000W	N/A	N/A	N/A	May 09, 2016	N/A	Conduction (CO05-HY)
EMI Test Receiver	Rohde & Schwarz	ESCI 7	100724	9kHz~7GHz	Aug. 26, 2015	May 09, 2016	Aug. 25, 2016	Conduction (CO05-HY)
LISN	Rohde & Schwarz	ENV216	100080	9kHz~30MHz	Dec. 02, 2015	May 09, 2016	Dec. 01, 2016	Conduction (CO05-HY)
LF Cable	HUBER + SUHNER	RG-214/U	LF01	N/A	Jan. 06, 2016	May 09, 2016	Jan. 05, 2017	Conduction (CO05-HY)
Pulse Limiter	Rohde & Schwarz	ESH3-Z2	100851	N/A	Jan. 08, 2016	May 09, 2016	Jan. 07, 2017	Conduction (CO05-HY)



5 Uncertainty of Evaluation

Uncertainty of Conducted Emission Measurement (150kHz ~ 30MHz)

Measuring Uncertainty for a Level of Confidence of 95% ($U = 2Uc(y)$)	2.26
---	------

Uncertainty of Radiated Emission Measurement (30 MHz ~ 1000 MHz)

Measuring Uncertainty for a Level of Confidence of 95% ($U = 2Uc(y)$)	4.90
---	------



Appendix A. Conducted Test Results

Test Engineer:	Bill Kuo	Temperature:	21~25	°C
Test Date:	2016/05/02 ~ 2016/05/08	Relative Humidity:	51~54	%

TEST RESULTS DATA
6dB and 26dB EBW and 99% OBW

Band IV									
Mod.	Data Rate	NTX	CH.	Freq. (MHz)	99% Bandwidth (MHz)	26 dB Bandwidth (MHz)	6 dB Bandwidth (MHz)	6dB Bandwidth min. Limit (MHz)	Pass/Fail
11a	6M bps	1	149	5745	18.2	26.35	16.36	0.5	Pass
11a	6Mbps	1	157	5785	18.35	27.5	16.4	0.5	Pass
11a	6Mbps	1	165	5825	18.35	29.4	16.4	0.5	Pass
HT20	MCS 0	1	149	5745	19.15	24.2	17.6	0.5	Pass
HT20	MCS 0	1	157	5785	19.1	25.1	17.6	0.5	Pass
HT20	MCS 0	1	165	5825	18.95	27.7	17.6	0.5	Pass
HT40	MCS 0	1	151	5755	36.7	45.72	35.52	0.5	Pass
HT40	MCS 0	1	159	5795	36.5	46.26	35.36	0.5	Pass
VHT20	MCS 0	1	149	5745	19.15	24.1	17.6	0.5	Pass
VHT20	MCS 0	1	157	5785	19.05	24.2	17.6	0.5	Pass
VHT20	MCS 0	1	165	5825	19.15	24	17.6	0.5	Pass
VHT40	MCS 0	1	151	5755	36.6	45.72	35.36	0.5	Pass
VHT40	MCS 0	1	159	5795	36.7	45.36	35.2	0.5	Pass
VHT80	MCS 0	1	155	5775	75.12	86.08	75.2	0.5	Pass

TEST RESULTS DATA
Average Power Table

Band IV										
Mod.	Data Rate	NTX	CH.	Freq. (MHz)	Duty Factor (dB)	Average Conducted Power (dBm)	FCC Conducted Power Limit (dBm)	DG (dBi)		Pass/Fail
11a	6M bps	1	149	5745	0.62	14.76	30.00	-3.60		Pass
11a	6Mbps	1	157	5785	0.62	14.93	30.00	-3.60		Pass
11a	6Mbps	1	165	5825	0.62	14.66	30.00	-3.60		Pass
HT20	MCS 0	1	149	5745	0.66	13.74	30.00	-3.60		Pass
HT20	MCS 0	1	157	5785	0.66	13.84	30.00	-3.60		Pass
HT20	MCS 0	1	165	5825	0.66	13.71	30.00	-3.60		Pass
HT40	MCS 0	1	151	5755	1.20	13.52	30.00	-3.60		Pass
HT40	MCS 0	1	159	5795	1.20	13.54	30.00	-3.60		Pass
VHT20	MCS 0	1	149	5745	0.84	10.68	30.00	-3.60		Pass
VHT20	MCS 0	1	157	5785	0.84	10.73	30.00	-3.60		Pass
VHT20	MCS 0	1	165	5825	0.84	10.54	30.00	-3.60		Pass
VHT40	MCS 0	1	151	5755	1.54	10.97	30.00	-3.60		Pass
VHT40	MCS 0	1	159	5795	1.54	10.99	30.00	-3.60		Pass
VHT80	MCS 0	1	155	5775	2.57	10.77	30.00	-3.60		Pass

TEST RESULTS DATA
Power Spectral Density

Band IV										
Mod.	Data Rate	NTX	CH.	Freq. (MHz)	Duty Factor (dB)	10log (500kHz /RBW) Factor (dB)	Average Power Density (dBm/500kHz)	Average PSD Limit (dBm/500kHz)	DG (dBi)	Pass/Fail
11a	6M bps	1	149	5745	0.62	2.22	0.15	30.00	-3.60	Pass
11a	6Mbps	1	157	5785	0.62	2.22	0.47	30.00	-3.60	Pass
11a	6Mbps	1	165	5825	0.62	2.22	0.33	30.00	-3.60	Pass
HT20	MCS 0	1	149	5745	0.66	2.22	-0.89	30.00	-3.60	Pass
HT20	MCS 0	1	157	5785	0.66	2.22	-1.21	30.00	-3.60	Pass
HT20	MCS 0	1	165	5825	0.66	2.22	-0.79	30.00	-3.60	Pass
HT40	MCS 0	1	151	5755	1.20	2.22	-3.92	30.00	-3.60	Pass
HT40	MCS 0	1	159	5795	1.20	2.22	-3.73	30.00	-3.60	Pass
VHT20	MCS 0	1	149	5745	0.84	2.22	-4.20	30.00	-3.60	Pass
VHT20	MCS 0	1	157	5785	0.84	2.22	-4.20	30.00	-3.60	Pass
VHT20	MCS 0	1	165	5825	0.84	2.22	-3.99	30.00	-3.60	Pass
VHT40	MCS 0	1	151	5755	1.54	2.22	-5.68	30.00	-3.60	Pass
VHT40	MCS 0	1	159	5795	1.54	2.22	-6.26	30.00	-3.60	Pass
VHT80	MCS 0	1	155	5775	2.57	2.22	-9.49	30.00	-3.60	Pass

TEST RESULTS DATA
Frequency Stability

Band IV										
Mod.	Data Rate	NTX	CH.	Freq. (MHz)	Center Frequency (MHz)	Frequency Deviation (MHz)	Frequency Stability (ppm)	Temperature (°C)	Voltage (V)	Note
11a	6M bps	1	149	5745	5745.000	0.000	0.00	20	3.6	
11a	6M bps	1	149	5745	5745.000	0.000	0.00	20	4.35	
11a	6M bps	1	149	5745	5745.000	0.000	0.00	20	3.8	
11a	6M bps	1	149	5745	5744.975	-0.025	-4.35	-30	3.8	
11a	6M bps	1	149	5745	5745.000	0.000	0.00	55	3.8	



Appendix B. Radiated Spurious Emission

Test Engineer :	J.C. Liang, Bill Chang, Ken Wu, and Kyle Jhuang	Temperature :	20~23°C
		Relative Humidity :	50~53%

Band 4 - 5725~5850MHz

WIFI 802.11a (Band Edge @ 3m)

WIFI Ant.	Note	Frequency (MHz)	Level (dBμV/m)	Over Limit (dB)	Limit Line (dBμV/m)	Read Level (dBμV)	Antenna Factor (dB/m)	Cable Loss (dB)	Preamp Factor (dB)	Ant Pos (cm)	Table Pos (deg)	Peak Avg. (P/A)	Pol. (H/V)	
802.11a CH 149 5745MHz		5631.2	48.93	-19.37	68.3	39.61	32.17	10.69	33.54	100	102	P	H	
		5692	50.73	-48.67	99.4	41.35	32.27	10.67	33.56	100	102	P	H	
		5719	51.3	-59.32	110.62	41.91	32.31	10.65	33.57	100	102	P	H	
		5724.6	53.72	-67.67	121.39	44.33	32.31	10.65	33.57	100	102	P	H	
		5745	105.26	-17.04	122.3	95.86	32.34	10.63	33.57	100	102	P	H	
		5745	97.98	-----	-----	88.58	32.34	10.63	33.57	100	102	A	H	
														H
														H
			5606.4	48.69	-19.61	68.3	39.37	32.14	10.71	33.53	136	152	P	V
			5650.6	49.17	-19.58	68.75	39.8	32.22	10.69	33.54	136	152	P	V
			5715.4	47.49	-62.12	109.61	38.12	32.29	10.65	33.57	136	152	P	V
			5725	51.52	-70.78	122.3	42.13	32.31	10.65	33.57	136	152	P	V
			5745	101.37	-20.93	122.3	91.97	32.34	10.63	33.57	136	152	P	V
			5745	93.9	-----	-----	84.5	32.34	10.63	33.57	136	152	A	V
														V
													V	



WIFI Ant. 1	Note	Frequency (MHz)	Level (dBμV/m)	Over Limit (dB)	Limit Line (dBμV/m)	Read Level (dBμV)	Antenna Factor (dB/m)	Cable Loss (dB)	Preamp Factor (dB)	Ant Pos (cm)	Table Pos (deg)	Peak Avg. (P/A)	Pol. (H/V)
		5626	48.71	-19.59	68.3	39.38	32.17	10.69	33.53	100	101	P	H
		5666	48.6	-31.58	80.18	39.26	32.22	10.67	33.55	100	101	P	H
		5716.8	48.99	-61.02	110.01	39.62	32.29	10.65	33.57	100	101	P	H
		5723.8	46.67	-72.89	119.56	37.28	32.31	10.65	33.57	100	101	P	H
		5785	105.82	-16.48	122.3	96.41	32.39	10.61	33.59	100	101	P	H
		5785	98.66	-----	-----	89.25	32.39	10.61	33.59	100	101	A	H
		5852.6	47.83	-68.54	116.37	38.18	32.48	10.78	33.61	100	101	P	H
		5860.2	47.3	-62.14	109.44	37.47	32.51	10.94	33.62	100	101	P	H
		5900.2	48.79	-37.82	86.61	38.75	32.56	11.11	33.63	100	101	P	H
		5925.4	48.72	-19.58	68.3	38.65	32.6	11.11	33.64	100	101	P	H
													H
													H
802.11a													
CH 157													
5785MHz		5647.8	49.03	-19.27	68.3	39.69	32.19	10.69	33.54	128	150	P	V
		5653.4	48.6	-22.23	70.83	39.23	32.22	10.69	33.54	128	150	P	V
		5712	49.3	-59.36	108.66	39.93	32.29	10.65	33.57	128	150	P	V
		5723	45.95	-71.79	117.74	36.56	32.31	10.65	33.57	128	150	P	V
		5785	101.57	-20.73	122.3	92.16	32.39	10.61	33.59	128	150	P	V
		5785	94.17	-----	-----	84.76	32.39	10.61	33.59	128	150	A	V
		5850.6	48.48	-72.45	120.93	38.83	32.48	10.78	33.61	128	150	P	V
		5855	48.25	-62.65	110.9	38.57	32.51	10.78	33.61	128	150	P	V
		5889.8	50.28	-44.04	94.32	40.41	32.56	10.94	33.63	128	150	P	V
		5931.8	49.33	-18.97	68.3	39.26	32.6	11.11	33.64	128	150	P	V
													V
													V



WiFi Ant. 1	Note	Frequency (MHz)	Level (dBμV/m)	Over Limit (dB)	Limit Line (dBμV/m)	Read Level (dBμV)	Antenna Factor (dB/m)	Cable Loss (dB)	Preamp Factor (dB)	Ant Pos (cm)	Table Pos (deg)	Peak Avg. (P/A)	Pol. (H/V)	
802.11a CH 165 5825MHz		5825	106.36	-15.94	122.3	96.72	32.46	10.78	33.6	100	101	P	H	
		5825	99.03	-----	-----	89.39	32.46	10.78	33.6	100	101	A	H	
		5851.4	49.5	-69.61	119.11	39.85	32.48	10.78	33.61	100	101	P	H	
		5864.6	49.58	-58.63	108.21	39.75	32.51	10.94	33.62	100	101	P	H	
		5877.2	50.24	-53.43	103.67	40.39	32.53	10.94	33.62	100	101	P	H	
		5936.4	48.82	-19.48	68.3	38.76	32.6	11.11	33.65	100	101	P	H	
														H
														H
			5825	100.52	-21.78	122.3	90.88	32.46	10.78	33.6	130	151	P	V
			5825	93.28	-----	-----	83.64	32.46	10.78	33.6	130	151	A	V
			5850.4	47.37	-74.02	121.39	37.72	32.48	10.78	33.61	130	151	P	V
			5874.6	49.46	-55.95	105.41	39.61	32.53	10.94	33.62	130	151	P	V
			5920.6	50.08	-21.46	71.54	40.03	32.58	11.11	33.64	130	151	P	V
			5941	50.98	-17.32	68.3	40.73	32.63	11.27	33.65	130	151	P	V
														V
														V
													V	
Remark	1. No other spurious found. 2. All results are PASS against Peak and Average limit line.													



Band 4 5725~5850MHz

WIFI 802.11a (Harmonic @ 3m)

WIFI Ant. 1	Note	Frequency (MHz)	Level (dBμV/m)	Over Limit (dB)	Limit Line (dBμV/m)	Read Level (dBμV)	Antenna Factor (dB/m)	Cable Loss (dB)	Preamp Factor (dB)	Ant Pos (cm)	Table Pos (deg)	Peak Avg. (P/A)	Pol. (H/V)
802.11a CH 149 5745MHz		11490	42.46	-31.54	74	52.7	39.91	15.59	65.74	100	0	P	H
		17235	41.19	-27.11	68.3	45.67	41	18.6	64.08	100	0	P	H
													H
													H
		11490	45.11	-28.89	74	55.35	39.91	15.59	65.74	100	0	P	V
		17235	43.08	-25.22	68.3	47.56	41	18.6	64.08	100	0	P	V
													V
													V
802.11a CH 157 5785MHz		11570	42.5	-31.5	74	52.76	39.76	15.64	65.66	100	0	P	H
		17355	40.24	-28.06	68.3	44.46	41.35	18.65	64.22	100	0	P	H
													H
													H
		11570	45.9	-28.1	74	56.16	39.76	15.64	65.66	100	0	P	V
		17355	40.79	-27.51	68.3	45.01	41.35	18.65	64.22	100	0	P	V
													V
													V
802.11a CH 165 5825MHz		11650	42.4	-31.6	74	52.71	39.62	15.69	65.62	100	0	P	H
		17475	41.45	-26.85	68.3	45.41	41.7	18.7	64.36	100	0	P	H
													H
													H
		11650	46.81	-27.19	74	57.12	39.62	15.69	65.62	100	0	P	V
		17475	41.52	-26.78	68.3	45.48	41.7	18.7	64.36	100	0	P	V
													V
													V
Remark	1. No other spurious found. 2. All results are PASS against Peak and Average limit line.												



Band 4 5725~5850MHz

WIFI 802.11n HT20 (Band Edge @ 3m)

WIFI Ant. 1	Note	Frequency (MHz)	Level (dBμV/m)	Over Limit (dB)	Limit Line (dBμV/m)	Read Level (dBμV)	Antenna Factor (dB/m)	Cable Loss (dB)	Preamp Factor (dB)	Ant Pos (cm)	Table Pos (deg)	Peak Avg. (P/A)	Pol. (H/V)	
802.11n HT20 CH 149 5745MHz		5622.6	48.77	-19.53	68.3	39.44	32.17	10.69	33.53	100	102	P	H	
		5693.6	51.25	-49.33	100.58	41.87	32.27	10.67	33.56	100	102	P	H	
		5719.2	48.06	-62.62	110.68	38.67	32.31	10.65	33.57	100	102	P	H	
		5721.4	54.72	-59.37	114.09	45.33	32.31	10.65	33.57	100	102	P	H	
		5745	103.83	-18.47	122.3	94.43	32.34	10.63	33.57	100	102	P	H	
		5745	96.6	-----	-----	87.2	32.34	10.63	33.57	100	102	A	H	
														H
														H
			5649.2	48.04	-20.26	68.3	38.7	32.19	10.69	33.54	129	150	P	V
			5692.8	48.03	-51.96	99.99	38.65	32.27	10.67	33.56	129	150	P	V
			5703.6	47.02	-59.29	106.31	37.64	32.29	10.65	33.56	129	150	P	V
			5725	51.44	-70.86	122.3	42.05	32.31	10.65	33.57	129	150	P	V
			5745	99.62	-22.68	122.3	90.22	32.34	10.63	33.57	129	150	P	V
			5745	92.14	-----	-----	82.74	32.34	10.63	33.57	129	150	A	V
														V
													V	



WIFI Ant. 1	Note	Frequency (MHz)	Level (dBμV/m)	Over Limit (dB)	Limit Line (dBμV/m)	Read Level (dBμV)	Antenna Factor (dB/m)	Cable Loss (dB)	Preamp Factor (dB)	Ant Pos (cm)	Table Pos (deg)	Peak Avg. (P/A)	Pol. (H/V)
		5614.2	47.68	-20.62	68.3	38.36	32.14	10.71	33.53	100	100	P	H
		5682.8	48.71	-43.9	92.61	39.36	32.24	10.67	33.56	100	100	P	H
		5715.2	47.69	-61.87	109.56	38.32	32.29	10.65	33.57	100	100	P	H
		5720.8	47.09	-65.63	112.72	37.7	32.31	10.65	33.57	100	100	P	H
		5785	104.54	-17.76	122.3	95.13	32.39	10.61	33.59	100	100	P	H
		5785	97.08	-----	-----	87.67	32.39	10.61	33.59	100	100	A	H
		5852.6	47.61	-68.76	116.37	37.96	32.48	10.78	33.61	100	100	P	H
		5873.2	49.47	-56.33	105.8	39.62	32.53	10.94	33.62	100	100	P	H
		5899.4	49.43	-37.77	87.2	39.56	32.56	10.94	33.63	100	100	P	H
		5942.2	48.44	-19.86	68.3	38.19	32.63	11.27	33.65	100	100	P	H
802.11n													H
HT20													H
CH 157		5601.2	48.39	-19.91	68.3	39.06	32.14	10.71	33.52	135	150	P	V
5785MHz		5672.6	48.87	-36.19	85.06	39.51	32.24	10.67	33.55	135	150	P	V
		5716.6	48.71	-61.24	109.95	39.34	32.29	10.65	33.57	135	150	P	V
		5723	46.65	-71.09	117.74	37.26	32.31	10.65	33.57	135	150	P	V
		5785	99.65	-22.65	122.3	90.24	32.39	10.61	33.59	135	150	P	V
		5785	92.19	-----	-----	82.78	32.39	10.61	33.59	135	150	A	V
		5853.2	48.35	-66.65	115	38.7	32.48	10.78	33.61	135	150	P	V
		5871.8	48.61	-57.58	106.19	38.76	32.53	10.94	33.62	135	150	P	V
		5904.8	48.63	-34.58	83.21	38.57	32.58	11.11	33.63	135	150	P	V
		5937.2	48.78	-19.52	68.3	38.72	32.6	11.11	33.65	135	150	P	V
													V
													V



WIFI Ant. 1	Note	Frequency (MHz)	Level (dBμV/m)	Over Limit (dB)	Limit Line (dBμV/m)	Read Level (dBμV)	Antenna Factor (dB/m)	Cable Loss (dB)	Preamp Factor (dB)	Ant Pos (cm)	Table Pos (deg)	Peak Avg. (P/A)	Pol. (H/V)	
802.11n HT20 CH 165 5825MHz		5825	104.96	-17.34	122.3	95.32	32.46	10.78	33.6	100	102	P	H	
		5825	97.6	-----	-----	87.96	32.46	10.78	33.6	100	102	A	H	
		5850	51.49	-70.81	122.3	41.84	32.48	10.78	33.61	100	102	P	H	
		5859.6	49.55	-60.06	109.61	39.88	32.51	10.78	33.62	100	102	P	H	
		5876.6	49.69	-54.42	104.11	39.84	32.53	10.94	33.62	100	102	P	H	
		5939.2	49.18	-19.12	68.3	39.09	32.63	11.11	33.65	100	102	P	H	
														H
														H
			5825	99.68	-22.62	122.3	90.04	32.46	10.78	33.6	133	149	P	V
			5825	92.47	-----	-----	82.83	32.46	10.78	33.6	133	149	A	V
			5850.6	48.81	-72.12	120.93	39.16	32.48	10.78	33.61	133	149	P	V
			5871.4	48.21	-58.1	106.31	38.36	32.53	10.94	33.62	133	149	P	V
			5877.2	49.87	-53.8	103.67	40.02	32.53	10.94	33.62	133	149	P	V
			5944.6	49.98	-18.32	68.3	39.73	32.63	11.27	33.65	133	149	P	V
														V
													V	
Remark	1. No other spurious found. 2. All results are PASS against Peak and Average limit line.													



Band 4 5725~5850MHz

WIFI 802.11n HT20 (Harmonic @ 3m)

WIFI Ant. 1	Note	Frequency (MHz)	Level (dBµV/m)	Over Limit (dB)	Limit Line (dBµV/m)	Read Level (dBµV)	Antenna Factor (dB/m)	Cable Loss (dB)	Preamp Factor (dB)	Ant Pos (cm)	Table Pos (deg)	Peak Avg. (P/A)	Pol. (H/V)	
802.11n HT20 CH 149 5745MHz		11490	42.98	-31.02	74	53.22	39.91	15.59	65.74	100	0	P	H	
		17235	41.44	-26.86	68.3	45.92	41	18.6	64.08	100	0	P	H	
													H	
													H	
			11490	43.55	-30.45	74	53.79	39.91	15.59	65.74	100	0	P	V
			17235	41.32	-26.98	68.3	45.8	41	18.6	64.08	100	0	P	V
														V
802.11n HT20 CH 157 5785MHz		11570	43.2	-30.8	74	53.46	39.76	15.64	65.66	100	0	P	H	
		17355	41.11	-27.19	68.3	45.33	41.35	18.65	64.22	100	0	P	H	
													H	
													H	
			11570	43.16	-30.84	74	53.42	39.76	15.64	65.66	100	0	P	V
			17355	41.37	-26.93	68.3	45.59	41.35	18.65	64.22	100	0	P	V
														V
802.11n HT20 CH 165 5825MHz		11650	42.05	-31.95	74	52.36	39.62	15.69	65.62	100	0	P	H	
		17475	41.1	-27.2	68.3	45.06	41.7	18.7	64.36	100	0	P	H	
													H	
													H	
			11650	45.81	-28.19	74	56.12	39.62	15.69	65.62	100	0	P	V
			17475	42.16	-26.14	68.3	46.12	41.7	18.7	64.36	100	0	P	V
														V
Remark	1. No other spurious found.													
	2. All results are PASS against Peak and Average limit line.													



Band 4 5725~5850MHz

WIFI 802.11n HT40 (Band Edge @ 3m)

WIFI Ant. 1	Note	Frequency (MHz)	Level (dBμV/m)	Over Limit (dB)	Limit Line (dBμV/m)	Read Level (dBμV)	Antenna Factor (dB/m)	Cable Loss (dB)	Preamp Factor (dB)	Ant Pos (cm)	Table Pos (deg)	Peak Avg. (P/A)	Pol. (H/V)
		5637.8	47.51	-20.79	68.3	38.17	32.19	10.69	33.54	100	100	P	H
		5652.4	48.24	-21.84	70.08	38.87	32.22	10.69	33.54	100	100	P	H
		5710.8	52	-56.33	108.33	42.63	32.29	10.65	33.57	100	100	P	H
		5724.4	61.91	-59.02	120.93	52.52	32.31	10.65	33.57	100	100	P	H
		5755	100.82	-21.48	122.3	91.4	32.36	10.63	33.57	100	100	P	H
		5755	92.24	-----	-----	82.82	32.36	10.63	33.57	100	100	A	H
		5852.4	46.55	-70.28	116.83	36.9	32.48	10.78	33.61	100	100	P	H
		5861.4	49.2	-59.91	109.11	39.37	32.51	10.94	33.62	100	100	P	H
		5895	48.68	-41.78	90.46	38.81	32.56	10.94	33.63	100	100	P	H
		5929.2	48.88	-19.42	68.3	38.81	32.6	11.11	33.64	100	100	P	H
802.11n													H
HT40													H
CH 151		5606.2	47.87	-20.43	68.3	38.55	32.14	10.71	33.53	134	150	P	V
5755MHz		5683.4	48.81	-44.24	93.05	39.46	32.24	10.67	33.56	134	150	P	V
		5713	53.21	-55.73	108.94	43.84	32.29	10.65	33.57	134	150	P	V
		5721	57.32	-55.86	113.18	47.93	32.31	10.65	33.57	134	150	P	V
		5755	97.63	-24.67	122.3	88.21	32.36	10.63	33.57	134	150	P	V
		5755	89.66	-----	-----	80.24	32.36	10.63	33.57	134	150	A	V
		5850.4	48.97	-72.42	121.39	39.32	32.48	10.78	33.61	134	150	P	V
		5856.4	49.89	-60.62	110.51	40.21	32.51	10.78	33.61	134	150	P	V
		5897.6	49.24	-39.3	88.54	39.37	32.56	10.94	33.63	134	150	P	V
		5933.2	49.47	-18.83	68.3	39.4	32.6	11.11	33.64	134	150	P	V
													V
													V



WIFI Ant. 1	Note	Frequency (MHz)	Level (dBμV/m)	Over Limit (dB)	Limit Line (dBμV/m)	Read Level (dBμV)	Antenna Factor (dB/m)	Cable Loss (dB)	Preamp Factor (dB)	Ant Pos (cm)	Table Pos (deg)	Peak Avg. (P/A)	Pol. (H/V)
		5605.4	49.15	-19.15	68.3	39.83	32.14	10.71	33.53	100	101	P	H
		5654.8	49.51	-22.36	71.87	40.15	32.22	10.69	33.55	100	101	P	H
		5701	47.57	-58.01	105.58	38.19	32.29	10.65	33.56	100	101	P	H
		5722.8	47.79	-69.49	117.28	38.4	32.31	10.65	33.57	100	101	P	H
		5795	101.27	-21.03	122.3	91.84	32.41	10.61	33.59	100	101	P	H
		5795	94.31	-----	-----	84.88	32.41	10.61	33.59	100	101	A	H
		5852.2	48.11	-69.17	117.28	38.46	32.48	10.78	33.61	100	101	P	H
		5865.2	49.57	-58.47	108.04	39.74	32.51	10.94	33.62	100	101	P	H
		5901.4	49.08	-36.65	85.73	39.04	32.56	11.11	33.63	100	101	P	H
		5931	49.54	-18.76	68.3	39.47	32.6	11.11	33.64	100	101	P	H
802.11n													H
HT40													H
CH 159		5602	48.36	-19.94	68.3	39.03	32.14	10.71	33.52	100	151	P	V
5795MHz		5689.2	48.97	-48.37	97.34	39.59	32.27	10.67	33.56	100	151	P	V
		5717.4	46.96	-63.21	110.17	37.59	32.29	10.65	33.57	100	151	P	V
		5725	47.03	-75.27	122.3	37.64	32.31	10.65	33.57	100	151	P	V
		5795	96.81	-25.49	122.3	87.38	32.41	10.61	33.59	100	151	P	V
		5795	89.47	-----	-----	80.04	32.41	10.61	33.59	100	151	P	V
		5851.4	47.78	-71.33	119.11	38.13	32.48	10.78	33.61	100	151	P	V
		5856.4	47.68	-62.83	110.51	38	32.51	10.78	33.61	100	151	P	V
		5898.4	49.95	-38	87.95	40.08	32.56	10.94	33.63	100	151	P	V
		5938.4	47.7	-20.6	68.3	37.64	32.6	11.11	33.65	100	151	P	V
													V
													V
Remark	1. No other spurious found. 2. All results are PASS against Peak and Average limit line.												



Band 4 5725~5850MHz

WIFI 802.11n HT40 (Harmonic @ 3m)

WIFI Ant. 1	Note	Frequency (MHz)	Level (dBμV/m)	Over Limit (dB)	Limit Line (dBμV/m)	Read Level (dBμV)	Antenna Factor (dB/m)	Cable Loss (dB)	Preamp Factor (dB)	Ant Pos (cm)	Table Pos (deg)	Peak Avg. (P/A)	Pol. (H/V)
802.11n HT40 CH 151 5755MHz		11510	42.23	-31.77	74	52.42	39.9	15.61	65.7	100	0	P	H
		17265	41.87	-26.43	68.3	46.27	41.1	18.62	64.12	100	0	P	H
													H
													H
		11510	42.83	-31.17	74	53.02	39.9	15.61	65.7	100	0	P	V
		17265	41.06	-27.24	68.3	45.46	41.1	18.62	64.12	100	0	P	V
													V
													V
802.11n HT40 CH 159 5795MHz		11590	41.76	-32.24	74	52.02	39.73	15.66	65.65	100	0	P	H
		17385	41.19	-27.11	68.3	45.34	41.45	18.66	64.26	100	0	P	H
													H
													H
		11590	44.92	-29.08	74	55.18	39.73	15.66	65.65	100	0	P	V
		17385	42.89	-25.41	68.3	47.04	41.45	18.66	64.26	100	0	P	V
													V
													V
Remark	1. No other spurious found. 2. All results are PASS against Peak and Average limit line.												



Band 4 5725~5850MHz

WIFI 802.11ac VHT80 (Band Edge @ 3m)

WIFI Ant. 1	Note	Frequency (MHz)	Level (dBμV/m)	Over Limit (dB)	Limit Line (dBμV/m)	Read Level (dBμV)	Antenna Factor (dB/m)	Cable Loss (dB)	Preamp Factor (dB)	Ant Pos (cm)	Table Pos (deg)	Peak Avg. (P/A)	Pol. (H/V)
		5606.8	49.28	-19.02	68.3	39.96	32.14	10.71	33.53	100	101	P	H
		5694.2	50.58	-50.44	101.02	41.2	32.27	10.67	33.56	100	101	P	H
		5716	50.03	-59.75	109.78	40.66	32.29	10.65	33.57	100	101	P	H
		5723.2	51.47	-66.73	118.2	42.08	32.31	10.65	33.57	100	101	P	H
		5775	96.13	-26.17	122.3	86.69	32.39	10.63	33.58	100	101	P	H
		5775	88.97	-----	-----	79.53	32.39	10.63	33.58	100	101	A	H
		5851.4	48.69	-70.42	119.11	39.04	32.48	10.78	33.61	100	101	P	H
		5863.2	48.5	-60.1	108.6	38.67	32.51	10.94	33.62	100	101	P	H
		5924.4	48.55	-20.19	68.74	38.48	32.6	11.11	33.64	100	101	P	H
		5926.8	49.01	-19.29	68.3	38.94	32.6	11.11	33.64	100	101	P	H
													H
													H
802.11ac VHT80 CH 155 5775MHz		5610.8	49.13	-19.17	68.3	39.81	32.14	10.71	33.53	137	151	P	V
		5697.6	49.07	-54.46	103.53	39.69	32.27	10.67	33.56	137	151	P	V
		5711.6	47.64	-60.91	108.55	38.27	32.29	10.65	33.57	137	151	P	V
		5724	48.49	-71.53	120.02	39.1	32.31	10.65	33.57	137	151	P	V
		5775	91.09	-31.21	122.3	81.65	32.39	10.63	33.58	137	151	P	V
		5775	86.14	-----	-----	76.7	32.39	10.63	33.58	137	151	A	V
		5850.4	47.74	-73.65	121.39	38.09	32.48	10.78	33.61	137	151	P	V
		5875	48.04	-57.26	105.3	38.19	32.53	10.94	33.62	137	151	P	V
		5921.4	49.72	-21.23	70.95	39.67	32.58	11.11	33.64	137	151	P	V
		5928.8	48.1	-20.2	68.3	38.03	32.6	11.11	33.64	137	151	P	V
													V
													V
Remark	1. No other spurious found. 2. All results are PASS against Peak and Average limit line.												



Band 4 5725~5850MHz

WIFI 802.11ac VHT80 (Harmonic @ 3m)

WIFI Ant. 1	Note	Frequency (MHz)	Level (dBμV/m)	Over Limit (dB)	Limit Line (dBμV/m)	Read Level (dBμV)	Antenna Factor (dB/m)	Cable Loss (dB)	Preamp Factor (dB)	Ant Pos (cm)	Table Pos (deg)	Peak Avg. (P/A)	Pol. (H/V)	
802.11ac VHT80 CH 155 5775MHz		11550	41.14	-32.86	74	51.37	39.8	15.64	65.67	100	0	P	H	
		17325	41.08	-27.22	68.3	45.38	41.25	18.63	64.18	100	0	P	H	
													H	
													H	
			11550	41.86	-32.14	74	52.09	39.8	15.64	65.67	100	0	P	V
			17325	41.85	-26.45	68.3	46.15	41.25	18.63	64.18	100	0	P	V
														V
Remark	1. No other spurious found. 2. All results are PASS against Peak and Average limit line.													



Emission below 1GHz

5GHz WIFI 802.11a (LF @ 3m)

WIFI	Note	Frequency	Level	Over	Limit	Read	Antenna	Cable	Preamp	Ant	Table	Peak	Pol.	
Ant.				Limit	Line	Level	Factor	Loss	Factor	Pos	Pos	Avg.		
1		(MHz)	(dBμV/m)	(dB)	(dBμV/m)	(dBμV)	(dB/m)	(dB)	(dB)	(cm)	(deg)	(P/A)	(H/V)	
5GHz 802.11a LF		30.81	26.14	-13.86	40	31.86	25.18	0.93	31.83			P	H	
		62.67	23.9	-16.1	40	42.47	12.05	1.17	31.79			P	H	
		160.14	26.31	-17.19	43.5	39.51	16.9	1.68	31.78			P	H	
		541.5	26.93	-19.07	46	31.17	24.68	3.03	31.95			P	H	
		829.2	32.24	-13.76	46	31.6	28.65	3.77	31.78			P	H	
		949.6	34.72	-11.28	46	31.26	30.6	3.89	31.03	213	172	P	H	
													H	
													H	
													H	
													H	
													H	
													H	
			38.1	35.07	-4.93	40	44.54	21.42	0.93	31.82	147	58	P	V
			84.81	25.91	-14.09	40	42.23	14.3	1.17	31.79			P	V
			120.72	23.02	-20.48	43.5	35.59	17.73	1.48	31.78			P	V
			638.1	29.77	-16.23	46	32.37	26.08	3.36	32.04			P	V
			827.1	32.63	-13.37	46	32.02	28.63	3.77	31.79			P	V
			949.6	34.5	-11.5	46	31.04	30.6	3.89	31.03			P	V
														V
														V
													V	
													V	
													V	
													V	
Remark	1. No other spurious found. 2. All results are PASS against limit line.													



Note symbol

*	Fundamental Frequency which can be ignored. However, the level of any unwanted emissions shall not exceed the level of the fundamental frequency.
!	Test result is over limit line.
P/A	Peak or Average
H/V	Horizontal or Vertical



A calculation example for radiated spurious emission is shown as below:

WIFI	Note	Frequency	Level	Over	Limit	Read	Antenna	Cable	Preamp	Ant	Table	Peak	Pol.
Ant.				Limit	Line	Level	Factor	Loss	Factor	Pos	Pos	Avg.	
1		(MHz)	(dBμV/m)	(dB)	(dBμV/m)	(dBμV)	(dB/m)	(dB)	(dB)	(cm)	(deg)	(P/A)	(H/V)
802.11b		2390	55.45	-18.55	74	54.51	32.22	4.58	35.86	103	308	P	H
CH 01													
2412MHz		2390	43.54	-10.46	54	42.6	32.22	4.58	35.86	103	308	A	H

- Level(dBμV/m) =
Antenna Factor(dB/m) + Cable Loss(dB) + Read Level(dBμV) - Preamp Factor(dB)
- Over Limit(dB) = Level(dBμV/m) – Limit Line(dBμV/m)

For Peak Limit @ 2390MHz:

- Level(dBμV/m)
= Antenna Factor(dB/m) + Cable Loss(dB) + Read Level(dBμV) - Preamp Factor(dB)
= 32.22(dB/m) + 4.58(dB) + 54.51(dBμV) – 35.86 (dB)
= 55.45 (dBμV/m)
- Over Limit(dB)
= Level(dBμV/m) – Limit Line(dBμV/m)
= 55.45(dBμV/m) – 74(dBμV/m)
= -18.55(dB)

For Average Limit @ 2390MHz:

- Level(dBμV/m)
= Antenna Factor(dB/m) + Cable Loss(dB) + Read Level(dBμV) - Preamp Factor(dB)
= 32.22(dB/m) + 4.58(dB) + 42.6(dBμV) – 35.86 (dB)
= 43.54 (dBμV/m)
- Over Limit(dB)
= Level(dBμV/m) – Limit Line(dBμV/m)
= 43.54(dBμV/m) – 54(dBμV/m)
= -10.46(dB)

Both peak and average measured complies with the limit line, so test result is “PASS”.



Appendix C. Radiated Spurious Emission Plots

Test Engineer :	J.C. Liang, Bill Chang, Ken Wu, and Kyle Jhuang	Temperature :	20~23°C
		Relative Humidity :	50~53%

Note symbol

-L	Low channel location
-R	High channel location



Band 4 - 5725~5850MHz
WIFI 802.11a (Band Edge @ 3m)

Table with 2 columns: WIFI (Band 4 5725~5850MHz Band Edge @ 3m), ANT (802.11a CH149 5745MHz). Row 1: 1, Horizontal, Vertical. Each plot shows Level (dBuV/m) vs Frequency (MHz) with a peak at 5745MHz. Includes site and condition details for both plots.



WIFI	Band 4 5725~5850MHz Band Edge @ 3m	
ANT	802.11a CH157 5785MHz – L	
1	Horizontal	Vertical
Peak	<p style="font-size: small;">Date: 2016-05-15 FCC PART 15E_BAND4_N</p> <p style="font-size: x-small;">Site : 03CH11-HY Condition : FCC PART 15E_BAND4_N 3m HORN 9120D-HF HORIZONTAL RBW:1000.000KHz VBW:3000.000KHz SWT:Auto Detector : Peak Project : 640143 Mode : II</p>	<p style="font-size: small;">Date: 2016-05-15 FCC PART 15E_BAND4_N</p> <p style="font-size: x-small;">Site : 03CH11-HY Condition : FCC PART 15E_BAND4_N 3m HORN 9120D-HF VERTICAL RBW:1000.000KHz VBW:3000.000KHz SWT:Auto Detector : Peak Project : 640143 Mode : II</p>

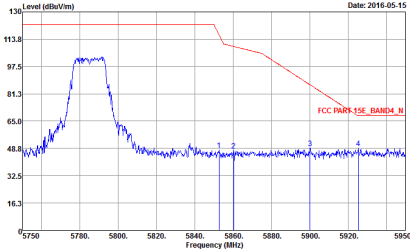
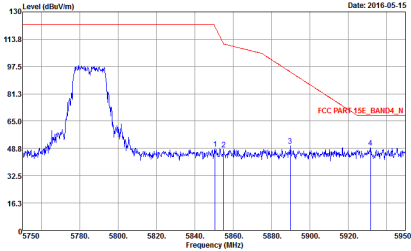

WIFI	Band 4 5725~5850MHz Band Edge @ 3m	
ANT	802.11a CH157 5785MHz – R	
1	Horizontal	Vertical
Peak	 <p>Site : 03CH11-HY Condition : FCC PART 15E_BAND4_N 3m HORN 9120D-HF HORIZONTAL RBW:1000.000KHz VBW:3000.000KHz SWT:Auto Detector : Peak Project : 640143 Mode : II</p>	 <p>Site : 03CH11-HY Condition : FCC PART 15E_BAND4_N 3m HORN 9120D-HF VERTICAL RBW:1000.000KHz VBW:3000.000KHz SWT:Auto Detector : Peak Project : 640143 Mode : II</p>

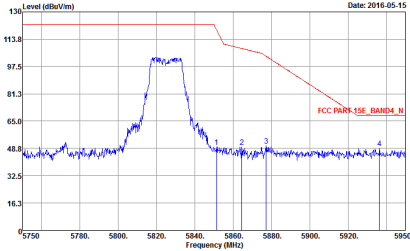
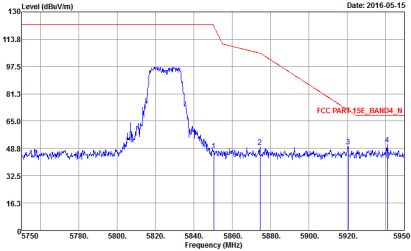

WIFI	Band 4 5725~5850MHz Band Edge @ 3m	
ANT	802.11a CH165 5825MHz	
1	Horizontal	Vertical
Peak	 <p>Site : 03CH11-HY Condition : FCC PART 15E_BAND4_N 3m HORN 9120D-HF HORIZONTAL RBW:1000.000KHz VBW:3000.000KHz SWT:Auto Detector : Peak Project : 640143 Mode : 12</p>	 <p>Site : 03CH11-HY Condition : FCC PART 15E_BAND4_N 3m HORN 9120D-HF VERTICAL RBW:1000.000KHz VBW:3000.000KHz SWT:Auto Detector : Peak Project : 640143 Mode : 12</p>



Band 4 5725~5850MHz
WIFI 802.11n HT20 (Band Edge @ 3m)

Table with 2 columns: Horizontal and Vertical. Each column contains a spectral plot showing Level (dBuV/m) vs Frequency (MHz) for the FCC PART 15E_BAND4_N. Includes metadata like Site, Condition, Detector, Project, and Mode.

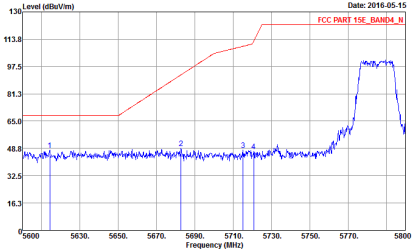
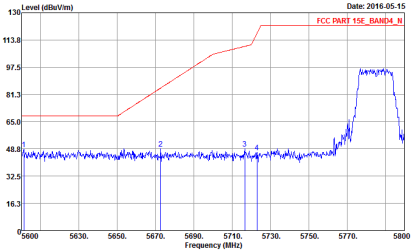

WIFI	Band 4 5725~5850MHz Band Edge @ 3m	
ANT	802.11n HT20 CH157 5785MHz - L	
1	Horizontal	Vertical
Peak	 <p style="font-size: small;">Date: 2016-05-15 FCC PART 15E_BAND4_N</p> <p style="font-size: x-small;">Site : 03CH11-HY Condition : FCC PART 15E_BAND4_N 3m HORN 9120D-HF HORIZONTAL RBW:1000.000KHz VBW:3000.000KHz SWT:Auto Detector : Peak Project : 640143 Mode : Z3</p>	 <p style="font-size: small;">Date: 2016-05-15 FCC PART 15E_BAND4_N</p> <p style="font-size: x-small;">Site : 03CH11-HY Condition : FCC PART 15E_BAND4_N 3m HORN 9120D-HF VERTICAL RBW:1000.000KHz VBW:3000.000KHz SWT:Auto Detector : Peak Project : 640143 Mode : Z3</p>

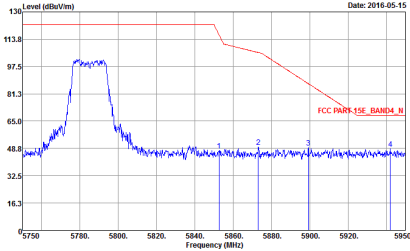
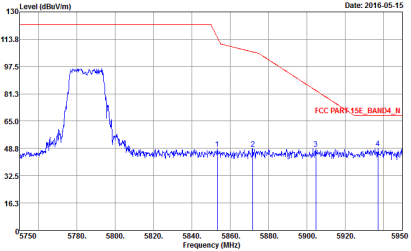

WIFI	Band 4 5725~5850MHz Band Edge @ 3m	
ANT	802.11n HT20 CH157 5785MHz - R	
1	Horizontal	Vertical
<p>Peak</p>	 <p>Date: 2016-05-15</p> <p>Site : 03CH11-HY Condition : FCC PART 15E_BAND4_N 3m HORN 9120D-HF HORIZONTAL RBW:1000.000KHz VBW:3000.000KHz SWT:Auto Detector : Peak Project : 640143 Mode : Z3</p>	 <p>Date: 2016-05-15</p> <p>Site : 03CH11-HY Condition : FCC PART 15E_BAND4_N 3m HORN 9120D-HF VERTICAL RBW:1000.000KHz VBW:3000.000KHz SWT:Auto Detector : Peak Project : 640143 Mode : Z3</p>

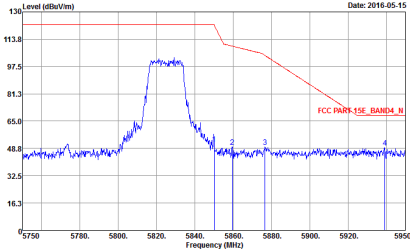
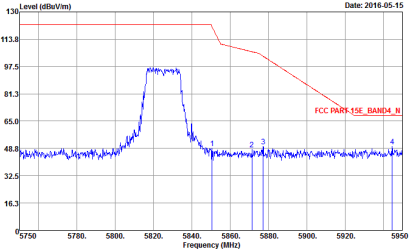

WIFI	Band 4 5725~5850MHz Band Edge @ 3m	
ANT	802.11n HT20 CH165 5825MHz	
1	Horizontal	Vertical
Peak	 <p>Site : 03CH11-HY Condition : FCC PART 15E_BAND4_N 3m HORN 9120D-HF HORIZONTAL RBW:1000.000KHz VBW:3000.000KHz SWT:Auto Detector : Peak Project : 640143 Mode : 24</p>	 <p>Site : 03CH11-HY Condition : FCC PART 15E_BAND4_N 3m HORN 9120D-HF VERTICAL RBW:1000.000KHz VBW:3000.000KHz SWT:Auto Detector : Peak Project : 640143 Mode : 24</p>



Band 4 5725~5850MHz
WIFI 802.11n HT40 (Band Edge @ 3m)

Table with 2 columns: Horizontal and Vertical. Each column contains a spectral plot showing Level (dBuV/m) vs Frequency (MHz) with a peak at 5755MHz. Includes metadata like Site, Condition, Detector, Project, and Mode.

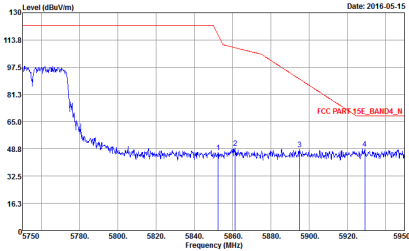
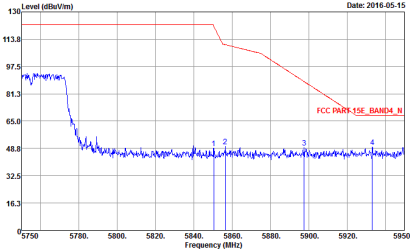

WIFI	Band 4 5725~5850MHz Band Edge @ 3m	
ANT	802.11n HT40 CH151 5755MHz - R	
1	Horizontal	Vertical
<p>Peak</p>	 <p>Date: 2016-05-15</p> <p>Site : 03CH11-HY Condition : FCC PART 15E_BAND4_N 3m HORN 9120D-HF HORIZONTAL RBW:1000.000KHz VBW:3000.000KHz SWT:Auto Detector : Peak Project : 640143 Mode : 32</p>	 <p>Date: 2016-05-15</p> <p>Site : 03CH11-HY Condition : FCC PART 15E_BAND4_N 3m HORN 9120D-HF VERTICAL RBW:1000.000KHz VBW:3000.000KHz SWT:Auto Detector : Peak Project : 640143 Mode : 32</p>

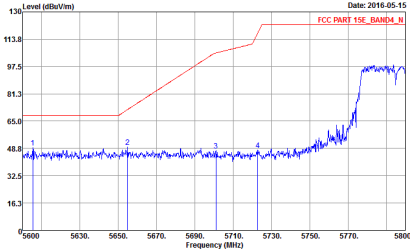
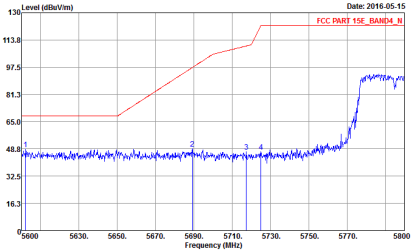

WIFI	Band 4 5725~5850MHz Band Edge @ 3m	
ANT	802.11n HT40 CH159 5795MHz - L	
1	Horizontal	Vertical
Peak	 <p>Date: 2016-05-15 FCC PART 15E_BAND4_N</p> <p>Site : 03CH11-HY Condition : FCC PART 15E_BAND4_N 3m HORN 9120D-HF HORIZONTAL RBW:1000.000KHz VBW:3000.000KHz SWT:Auto Detector : Peak Project : 640143 Mode : 33</p>	 <p>Date: 2016-05-15 FCC PART 15E_BAND4_N</p> <p>Site : 03CH11-HY Condition : FCC PART 15E_BAND4_N 3m HORN 9120D-HF VERTICAL RBW:1000.000KHz VBW:3000.000KHz SWT:Auto Detector : Peak Project : 640143 Mode : 33</p>

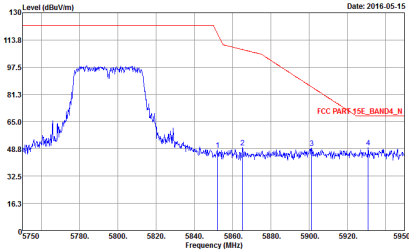
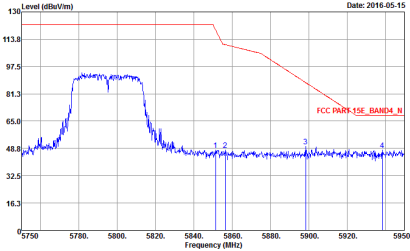

WIFI	Band 4 5725~5850MHz Band Edge @ 3m	
ANT	802.11n HT40 CH159 5795MHz - R	
1	Horizontal	Vertical
<p>Peak</p>	 <p>Date: 2016-05-15</p> <p>Site : 03CH11-HY Condition : FCC PART 15E_BAND4_N 3m HORN 9120D-HF HORIZONTAL RBW:1000.000KHz VBW:3000.000KHz SWT:Auto Detector : Peak Project : 640143 Mode : 33</p>	 <p>Date: 2016-05-15</p> <p>Site : 03CH11-HY Condition : FCC PART 15E_BAND4_N 3m HORN 9120D-HF VERTICAL RBW:1000.000KHz VBW:3000.000KHz SWT:Auto Detector : Peak Project : 640143 Mode : 33</p>



Band 4 5725~5850MHz
WIFI 802.11ac VHT80 (Band Edge @ 3m)

Table with 2 columns: Horizontal and Vertical. Each column contains a spectral plot of Level (dBuV/m) vs Frequency (MHz) and associated test parameters like Site, Condition, Detector, Project, and Mode.

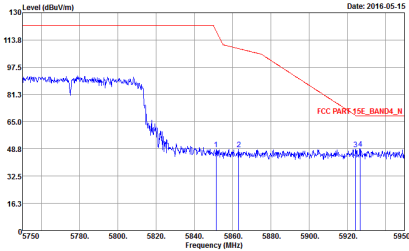
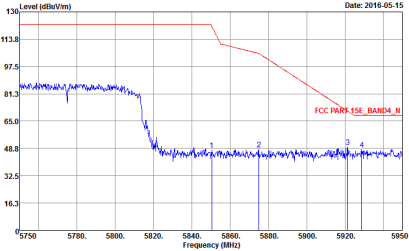

WIFI	Band 4 5725~5850MHz Band Edge @ 3m	
ANT	802.11ac VHT80 CH155 5775MHz - R	
1	Horizontal	Vertical
Peak	 <p>Date: 2016-05-15</p> <p>Site : 03CH11-HY Condition : FCC PART 15E_BAND4_N 3m HORN 9120D-HF HORIZONTAL RBW:1000.000KHz VBW:3000.000KHz SWT:Auto Detector : Peak Project : 640143 Mode : 37</p>	 <p>Date: 2016-05-15</p> <p>Site : 03CH11-HY Condition : FCC PART 15E_BAND4_N 3m HORN 9120D-HF VERTICAL RBW:1000.000KHz VBW:3000.000KHz SWT:Auto Detector : Peak Project : 640143 Mode : 37</p>



Band 4 - 5725~5850MHz
WIFI 802.11a (Harmonic @ 3m)

WIFI	Band 4 5725~5850MHz Harmonic @ 3m	
ANT	802.11a CH149 5745MHz	
1	Horizontal	Vertical
Peak Avg.	<p>Site : 03CH11-HY Condition : FCC PART 15E_BAND4_N 3m HORN 9120D-HF HORIZONTAL Detector : Peak Project : 640143 Mode : 10</p>	<p>Site : 03CH11-HY Condition : FCC PART 15E_BAND4_N 3m HORN 9120D-HF VERTICAL Detector : Peak Project : 640143 Mode : 10</p>

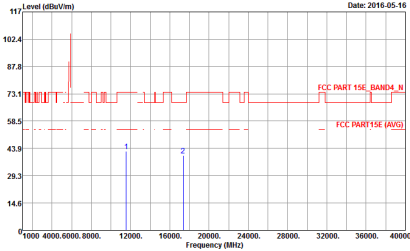
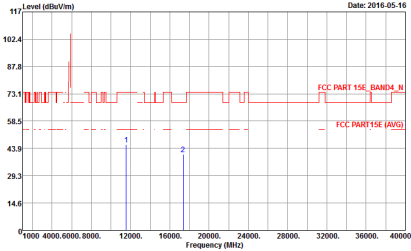

WIFI	Band 4 5725~5850MHz Harmonic @ 3m	
ANT	802.11a CH157 5785MHz	
1	Horizontal	Vertical
<p>Peak</p> <p>Avg.</p>	 <p>Site : 03CH11-HY Condition : FCC PART 15E_BAND4_N 3m HORN 9120D-HF HORIZONTAL Detector : Peak Project : 640143 Mode : II</p>	 <p>Site : 03CH11-HY Condition : FCC PART 15E_BAND4_N 3m HORN 9120D-HF VERTICAL Detector : Peak Project : 640143 Mode : II</p>

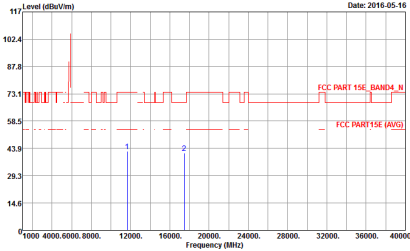
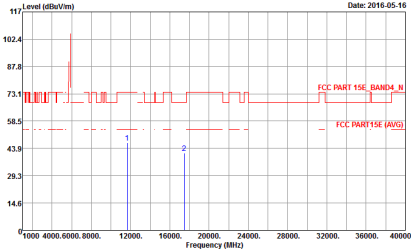

WIFI	Band 4 5725~5850MHz Harmonic @ 3m	
ANT	802.11a CH165 5825MHz	
1	Horizontal	Vertical
<p>Peak</p> <p>Avg.</p>	 <p>Date: 2016-05-16</p> <p>Site : 03CH11-HY Condition : FCC PART 15E_BAND4_N 3m HORN 9120D-HF HORIZONTAL Detector : Peak Project : 640143 Mode : 12</p>	 <p>Date: 2016-05-16</p> <p>Site : 03CH11-HY Condition : FCC PART 15E_BAND4_N 3m HORN 9120D-HF VERTICAL Detector : Peak Project : 640143 Mode : 12</p>

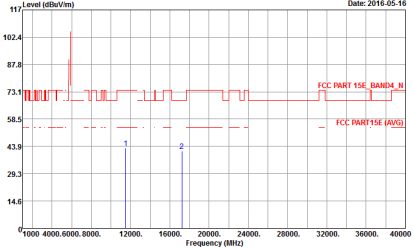
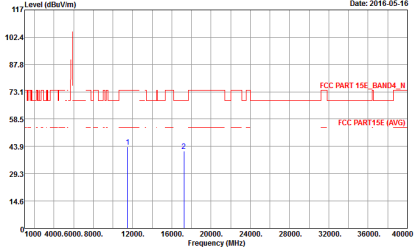

Band 4 5725~5850MHz
WIFI 802.11n HT20 (Harmonic @ 3m)

WIFI	Band 4 5725~5850MHz Harmonic @ 3m	
ANT	802.11n HT20 CH149 5745MHz	
1	Horizontal	Vertical
<p>Peak</p> <p>Avg.</p>	 <p>Site : 03CH11-HY Condition : FCC PART 15E_BAND4_N 3m HORN 9120D-HF HORIZONTAL Detector : Peak Project : 640143 Mode : 22</p>	 <p>Site : 03CH11-HY Condition : FCC PART 15E_BAND4_N 3m HORN 9120D-HF VERTICAL Detector : Peak Project : 640143 Mode : 22</p>



WIFI	Band 4 5725~5850MHz Harmonic @ 3m	
ANT	802.11n HT20 CH157 5785MHz	
1	Horizontal	Vertical
Peak Avg.	<p>Site : 03CH11-HY Condition : FCC PART 15E_BAND4_N 3m HORN 9120D-HF HORIZONTAL Detector : Peak Project : 640143 Mode : Z3</p>	<p>Site : 03CH11-HY Condition : FCC PART 15E_BAND4_N 3m HORN 9120D-HF VERTICAL Detector : Peak Project : 640143 Mode : Z3</p>



WIFI	Band 4 5725~5850MHz Harmonic @ 3m	
ANT	802.11n HT20 CH165 5825MHz	
1	Horizontal	Vertical
Peak Avg.	<p>Site : 03CH11-HY Condition : FCC PART 15E_BAND4_N 3m HORN 9120D-HF HORIZONTAL Detector : Peak Project : 640143 Mode : 24</p>	<p>Site : 03CH11-HY Condition : FCC PART 15E_BAND4_N 3m HORN 9120D-HF VERTICAL Detector : Peak Project : 640143 Mode : 24</p>



Band 4 5725~5850MHz
WIFI 802.11n HT40 (Harmonic @ 3m)

Table with 2 main columns: Horizontal and Vertical. Each column contains a spectral plot of Level (dBuV/m) vs Frequency (MHz) and associated test parameters like Site, Condition, Detector, Project, and Mode.

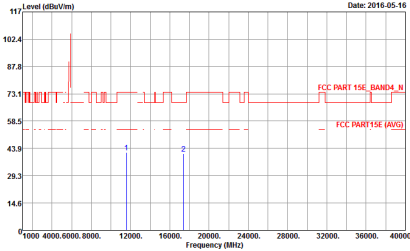
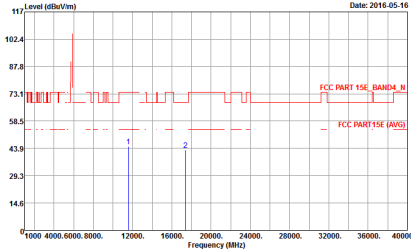

WIFI	Band 4 5725~5850MHz Harmonic @ 3m	
ANT	802.11n HT40 CH159 5795MHz	
1	Horizontal	Vertical
<p>Peak Avg.</p>	 <p>Site : 03CH11-HY Condition : FCC PART 15E_BAND4_N 3m HORN 9120D-HF HORIZONTAL Detector : Peak Project : 640143 Mode : 33</p>	 <p>Site : 03CH11-HY Condition : FCC PART 15E_BAND4_N 3m HORN 9120D-HF VERTICAL Detector : Peak Project : 640143 Mode : 33</p>

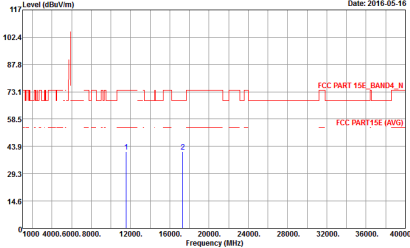
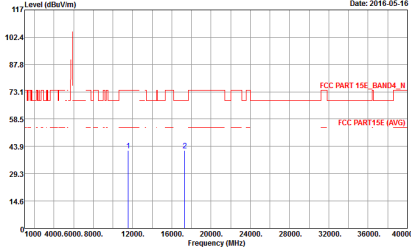

Band 4 5725~5850MHz
WIFI 802.11ac VHT80 (Harmonic @ 3m)

WIFI	Band 4 5725~5850MHz Harmonic @ 3m	
ANT	802.11ac VHT80 CH155 5775MHz	
1	Horizontal	Vertical
<p>Peak</p> <p>Avg.</p>	 <p>Date: 2016-05-16</p> <p>Site : 03CH11-HY Condition : FCC PART 15E_BAND4_N 3m HORN 9120D-HF HORIZONTAL Detector : Peak Project : 640143 Mode : 37</p>	 <p>Date: 2016-05-16</p> <p>Site : 03CH11-HY Condition : FCC PART 15E_BAND4_N 3m HORN 9120D-HF VERTICAL Detector : Peak Project : 640143 Mode : 37</p>



Emission below 1GHz
5GHz WIFI 802.11a (LF)

WIFI	5GHz 5725~5850MHz	
ANT	802.11a LF	
1	Horizontal	Vertical
QP / Peak	<p>Site : 03CH11-HY Condition : FCC PART 15E_BAND4_N 3m BI-LOG 6111D-LF_ETC HORIZONTAL Detector : Peak Project : 640143 Mode : 39</p>	<p>Site : 03CH11-HY Condition : FCC PART 15E_BAND4_N 3m BI-LOG 6111D-LF_ETC VERTICAL Detector : Peak Project : 640143 Mode : 39</p>

Appendix D. Duty Cycle Plots

Band	Duty Cycle(%)	T(us)	1/T(kHz)	VBW Setting
802.11a	86.61	1358	0.736377025	1kHz
5GHz 802.11n HT20	85.85	1274	0.784929356	1kHz
5GHz 802.11n HT40	75.90	630	1.587301587	3kHz
5GHz 802.11ac VHT20	82.35	980	1.020408163	3kHz
5GHz 802.11ac VHT40	70.12	488	2.049180328	3kHz
5GHz 802.11ac VHT80	55.36	248	4.032258065	10kHz

802.11a

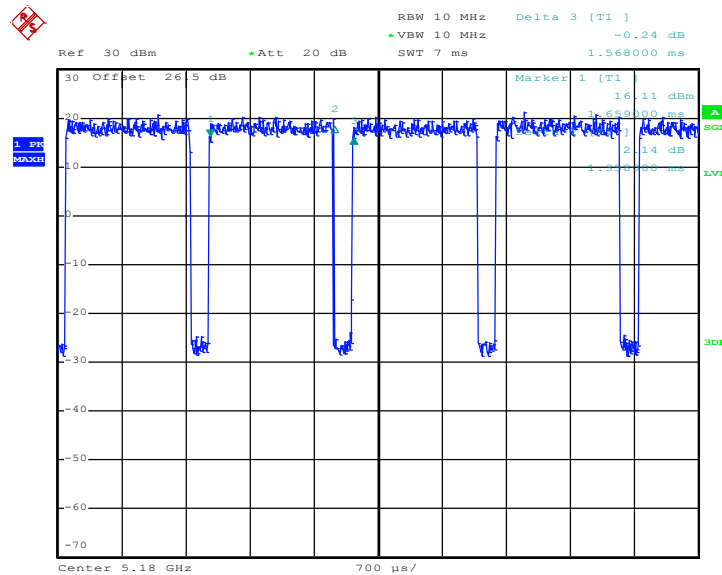

Date: 2.MAY.2016 13:51:45



802.11n HT20

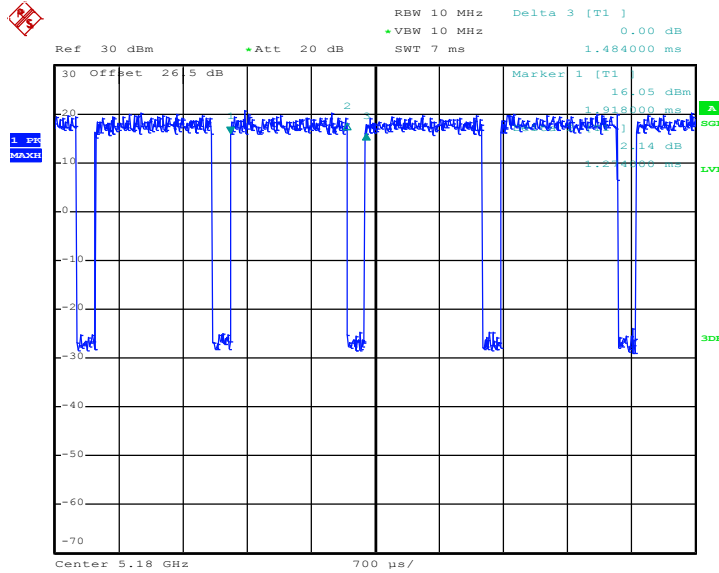

Date: 2.MAY.2016 13:53:09

802.11n HT40

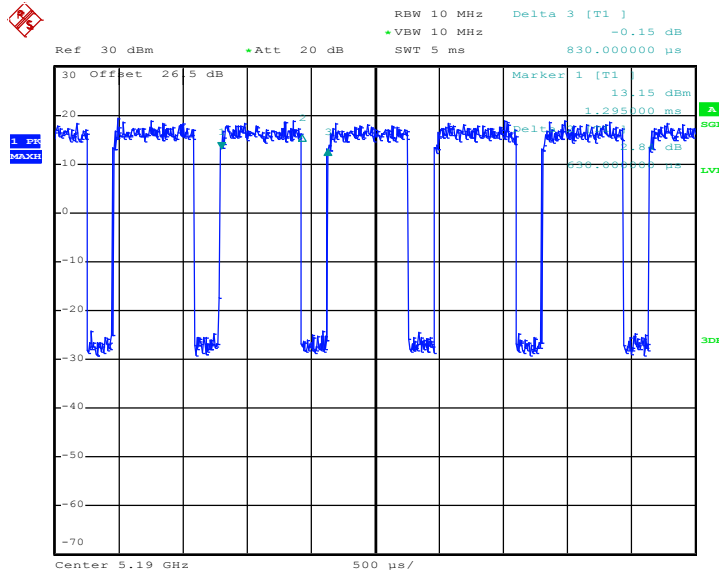

Date: 2.MAY.2016 13:54:01



802.11ac VHT20

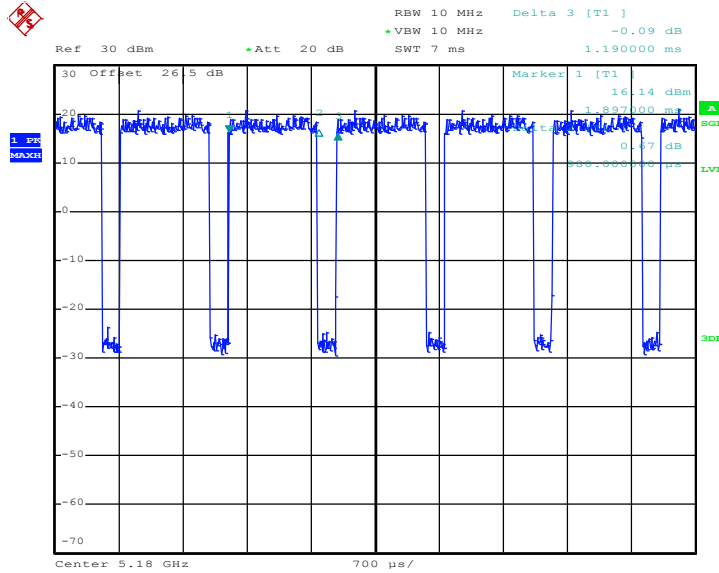

Date: 2.MAY.2016 13:55:36

802.11ac VHT40

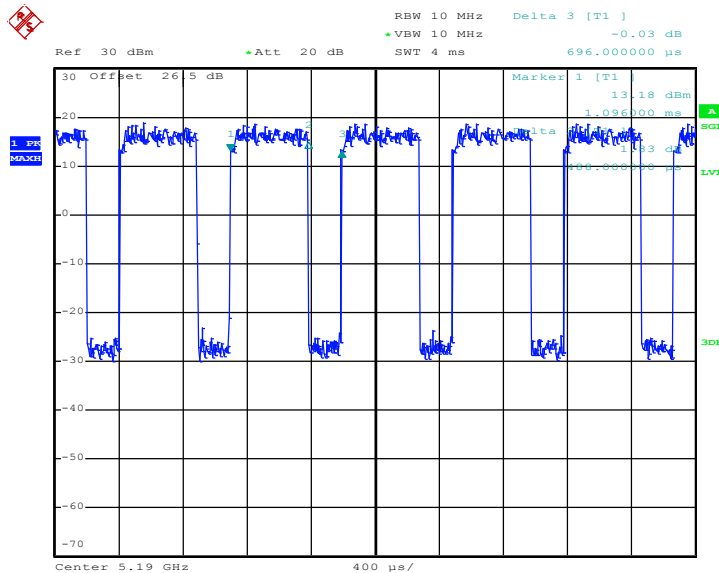

Date: 2.MAY.2016 13:58:29

