

FC

Test Report

Product Name	Eee PC
Model No.	Eee PC X101H
FCC ID.	MSQ-X101HNB047H

Applicant	ASUSTeK COMPUTER INC.
Address	No. 150, Li-Te Rd., Peitou, Taipei, Taiwan, R.O.C.

Date of Receipt	June 02, 2011
Issued Date	July 20, 2011
Report No.	116118-RFUSP43V01
Report Version	V1.0

The Test Results relate only to the samples tested.

The test report shall not be reproduced except in full without the written approval of QuieTek Corporation.

This report must not be used to claim product endorsement by NVLAP any agency of the U.S. Government

Test Report Certification

Issued Date: July 20, 2011

Report No.: 116118-RFUSP43V01



Product Name	Eee PC
Applicant	ASUSTeK COMPUTER INC.
Address	No. 150, Li-Te Rd., Peitou, Taipei, Taiwan, R.O.C.
Manufacturer	1. PEGATRON CORPORATION Taoyuan Mfg 2. Protek (Shanghai) Limited. 3. Tech-Com(Shanghai) Computer Co. Ltd.
Model No.	Eee PC X101H
FCC ID.	MSQ-X101HNB047H
EUT Rated Voltage	AC 100-240V, 50-60Hz
EUT Test Voltage	AC 120V/ 60Hz
Trade Name	ASUS
Applicable Standard	FCC CFR Title 47 Part 15 Subpart C: 2010 ANSI C63.4: 2009
Test Result	Complied

The Test Results relate only to the samples tested.

The test report shall not be reproduced except in full without the written approval of Quietek Corporation.

This report must not be used to claim product endorsement by NVLAP any agency of the U.S. Government

Documented By : Rita Huang
(Senior Adm. Specialist / Rita Huang)



Tested By : Henk Huang
(Engineer / Henk Huang)



Approved By : Vincent Lin
(Manager / Vincent Lin)

TABLE OF CONTENTS

Description	Page
1. GENERAL INFORMATION	5
1.1. EUT Description.....	5
1.2. Operational Description.....	7
1.3. Tested System Details.....	8
1.4. Configuration of Tested System	8
1.5. EUT Exercise Software	9
1.6. Test Facility	10
2. CONDUCTED EMISSION	11
2.1. Test Equipment.....	11
2.2. Test Setup	11
2.3. Limits.....	12
2.4. Test Procedure	12
2.5. Uncertainty	12
2.6. Test Result of Conducted Emission.....	13
3. PEAK POWER OUTPUT	15
3.1. Test Equipment.....	15
3.2. Test Setup	15
3.3. Limit.....	15
3.4. Test Procedure	15
3.5. Uncertainty	15
3.6. Test Result of Peak Power Output.....	16
4. RADIATED EMISSION	18
4.1. Test Equipment.....	18
4.2. Test Setup	18
4.3. Limits.....	19
4.4. Test Procedure	20
4.5. Uncertainty	20
4.6. Test Result of Radiated Emission.....	21
5. RF ANTENNA CONDUCTED TEST	29
5.1. Test Equipment.....	29
5.2. Test Setup	29
5.3. Limits.....	29
5.4. Test Procedure	29
5.5. Uncertainty	29
5.6. Test Result of RF Antenna Conducted Test	30
6. BAND EDGE	42
6.1. Test Equipment.....	42
6.2. Test Setup	43
6.3. Limit.....	44
6.4. Test Procedure	44
6.5. Uncertainty	44
6.6. Test Result of Band Edge	45
7. CHANNEL NUMBER.....	53
7.1. Test Equipment.....	53
7.2. Test Setup	53
7.3. Limit.....	53
7.4. Test Procedure	53
7.5. Uncertainty	53
7.6. Test Result of Channel Number.....	54
8. CHANNEL SEPARATION.....	56
8.1. Test Equipment.....	56
8.2. Test Setup	56
8.3. Limit.....	56
8.4. Test Procedure	56
8.5. Uncertainty	56
8.6. Test Result of Channel Separation.....	57
9. DWELL TIME.....	61
9.1. Test Equipment.....	61

9.2.	Test Setup	61
9.3.	Limit	61
9.4.	Test Procedure	61
9.5.	Uncertainty	61
9.6.	Test Result of Dwell Time	62
10.	OCCUPIED BANDWIDTH	66
10.1.	Test Equipment	66
10.2.	Test Setup	66
10.3.	Limits	66
10.4.	Test Procedure	66
10.5.	Uncertainty	66
10.6.	Test Result of Occupied Bandwidth	67
11.	EMI REDUCTION METHOD DURING COMPLIANCE TESTING	73

Attachment 1: EUT Test Photographs

Attachment 2: EUT Detailed Photographs

1. GENERAL INFORMATION

1.1. EUT Description

Product Name	Eee PC
Trade Name	ASUS
Model No.	Eee PC X101H
FCC ID.	MSQ-X101HNB047H
Frequency Range	2402 – 2480MHz
Channel Number	79
Type of Modulation	FHSS: GFSK(1Mbps) / π /4DQPSK(2Mbps) / 8DPSK(3Mbps)
Antenna Type	PIFA
Channel Control	Auto
Antenna Gain	Refer to the table “Antenna List”
Power Adapter	MFR: PI, M/N: AD820M0 Input: AC 100-240V, 50-60Hz, 0.8A Output: DC 19V, 1.58A Cable Out: Non-Shielded, 2.4m, with one ferrite core bonded.
Contain Module	Broadcom/ BCM94313HMGB (AW-NB047H)

Antenna List

No.	Manufacturer	Part No.	Peak Gain
1	INPAQ	WA-P-LA-02-041 (Main) WA-P-LA-01-020 (Aux)	2.4dBi in 2.4 GHz
2	YAGEO	CAN43131WLAS05611 (Main) CAN43131WLAS05612 (Aux)	1.79dBi in 2.4 GHz

Note:

1. The antenna of EUT is conform to FCC 15.203.
2. Only the higher gain antenna was tested and recorded in this report.

Frequency of Each Channel:

Channel	Frequency	Channel	Frequency	Channel	Frequency	Channel	Frequency
Channel 00:	2402 MHz	Channel 20:	2422 MHz	Channel 40:	2442 MHz	Channel 60:	2462 MHz
Channel 01:	2403 MHz	Channel 21:	2423 MHz	Channel 41:	2443 MHz	Channel 61:	2463 MHz
Channel 02:	2404 MHz	Channel 22:	2424 MHz	Channel 42:	2444 MHz	Channel 62:	2464 MHz
Channel 03:	2405 MHz	Channel 23:	2425 MHz	Channel 43:	2445 MHz	Channel 63:	2465 MHz
Channel 04:	2406 MHz	Channel 24:	2426 MHz	Channel 44:	2446 MHz	Channel 64:	2466 MHz
Channel 05:	2407 MHz	Channel 25:	2427 MHz	Channel 45:	2447 MHz	Channel 65:	2467 MHz
Channel 06:	2408 MHz	Channel 26:	2428 MHz	Channel 46:	2448 MHz	Channel 66:	2468 MHz
Channel 07:	2409 MHz	Channel 27:	2429 MHz	Channel 47:	2449 MHz	Channel 67:	2469 MHz
Channel 08:	2410 MHz	Channel 28:	2430 MHz	Channel 48:	2450 MHz	Channel 68:	2470 MHz
Channel 09:	2411 MHz	Channel 29:	2431 MHz	Channel 49:	2451 MHz	Channel 69:	2471 MHz
Channel 10:	2412 MHz	Channel 30:	2432 MHz	Channel 50:	2452 MHz	Channel 70:	2472 MHz
Channel 11:	2413 MHz	Channel 31:	2433 MHz	Channel 51:	2453 MHz	Channel 71:	2473 MHz
Channel 12:	2414 MHz	Channel 32:	2434 MHz	Channel 52:	2454 MHz	Channel 72:	2474 MHz
Channel 13:	2415 MHz	Channel 33:	2435 MHz	Channel 53:	2455 MHz	Channel 73:	2475 MHz
Channel 14:	2416 MHz	Channel 34:	2436 MHz	Channel 54:	2456 MHz	Channel 74:	2476 MHz
Channel 15:	2417 MHz	Channel 35:	2437 MHz	Channel 55:	2457 MHz	Channel 75:	2477 MHz
Channel 16:	2418 MHz	Channel 36:	2438 MHz	Channel 56:	2458 MHz	Channel 76:	2478 MHz
Channel 17:	2419 MHz	Channel 37:	2439 MHz	Channel 57:	2459 MHz	Channel 77:	2479 MHz
Channel 18:	2420 MHz	Channel 38:	2440 MHz	Channel 58:	2460 MHz	Channel 78:	2480 MHz
Channel 19:	2421 MHz	Channel 39:	2441 MHz	Channel 59:	2461 MHz		

Note:

1. This device is an Eee PC, Contains functions and so on WiFi 、Bluetooth , This report for Bluetooth.
2. These tests were conducted on a sample for the purpose of demonstrating compliance of Bluetooth transmitter with Part 15 Subpart C Paragraph 15.247 for spread spectrum devices.
3. Regarding to the operation frequency, the lowest, middle and highest frequency are selected to perform the test.

1.3. Tested System Details

The types for all equipment, plus descriptions of all cables used in the tested system (including inserted cards) are:

Product	Manufacturer	Model No.	Serial No.	FCC ID	Power Cord
1 Monitor	LG	W2261VT	907YHZK07373	DoC	Non-Shielded, 1.8m
2 iPod nano	Apple	A1199	SU7047UXVQ5	N/A	N/A
3 USB Mouse	DELL	MO56UOA	G0Y02ES2	DoC	N/A
4 Microphone & Earphone	Ergotech	ET-E201	N/A	N/A	N/A

Signal Cable Type	Signal cable Description
A VGA Cable	Shielded, 1.8m with two ferrite cores bonded
B IPOD Cable	Shielded, 1.2m
C USB Mouse Cable	Shielded, 1.8m
D Microphone & Earphone Cable	Non-Shielded, 1.6m
E RJ45 Cable	Non-Shielded, 2.0m

1.4. Configuration of Tested System

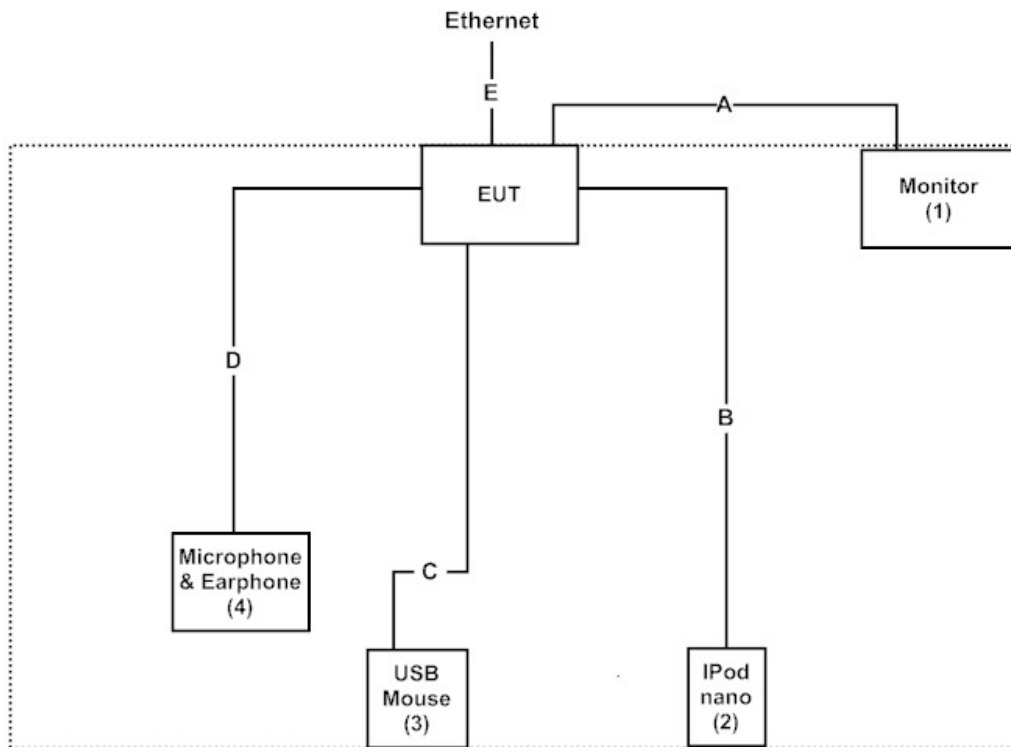

1.5. EUT Exercise Software

- (1) Setup the EUT as shown in Section 1.4.
- (2) Execute “BTUSB v18.3.exe” on the EUT.
- (3) Configure the test mode, the test channel, and the data rate.
- (4) Press “OK” to start the continuous Transmit.
- (5) Verify that the EUT works properly.

1.6. Test Facility

Ambient conditions in the laboratory:

Items	Required (IEC 68-1)	Actual
Temperature (°C)	15-35	20-35
Humidity (%RH)	25-75	30-65
Barometric pressure (mbar)	860-1060	950-1000

The related certificate for our laboratories about the test site and management system can be downloaded from Quietek Corporation’s Web Site: <http://www.quietek.com/tw/ctg/cts/accreditations.htm>
 The address and introduction of Quietek Corporation’s laboratories can be founded in our Web site: <http://www.quietek.com/>

Site Description: File on
 Federal Communications Commission
 FCC Engineering Laboratory
 7435 Oakland Mills Road
 Columbia, MD 21046
 Registration Number: 92195



Accreditation on NVLAP
 NVLAP Lab Code: 200533-0



Site Name: Quietek Corporation
 Site Address: No.5-22, Ruishukeng,
 Linkou Dist. New Taipei City 24451,
 Taiwan, R.O.C.
 TEL: 886-2-8601-3788 / FAX : 886-2-8601-3789
 E-Mail : service@quietek.com

FCC Accreditation Number: TW1014



2. Conducted Emission

2.1. Test Equipment

The following test equipment are used during the conducted emission test:

Item	Instrument	Manufacturer	Type No./Serial No	Last Cal.	Remark
1	Test Receiver	R & S	ESCS 30/825442/014	Feb., 2011	
2	L.I.S.N.	R & S	ESH3-Z5/825562/002	Feb., 2011	EUT
3	L.I.S.N.	R & S	ENV4200/848411/010	Feb., 2011	Peripherals
4	Pulse Limiter	R & S	ESH3-Z2/100410	July, 2011	
5	No.1 Shielded Room			N/A	

Note: All instruments are calibrated every one year.

2.2. Test Setup

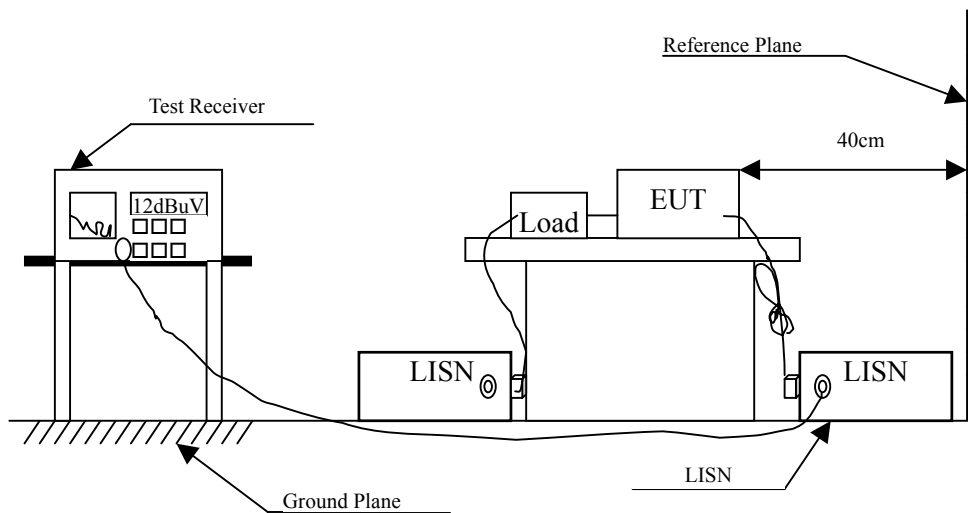

2.3. Limits

FCC Part 15 Subpart C Paragraph 15.207 (dBuV) Limit		
Frequency MHz	Limits	
	QP	AV
0.15 - 0.50	66-56	56-46
0.50-5.0	56	46
5.0 - 30	60	50

Remarks: In the above table, the tighter limit applies at the band edges.

2.4. Test Procedure

The EUT and Peripherals are connected to the main power through a line impedance stabilization network (L.I.S.N.). This provides a 50 ohm /50uH coupling impedance for the measuring equipment. The peripheral devices are also connected to the main power through a LISN that provides a 50ohm /50uH coupling impedance with 50ohm termination. (Please refer to the block diagram of the test setup and photographs.)

Both sides of A.C. line are checked for maximum conducted interference. In order to find the maximum emission, the relative positions of equipment and all the interface cables must be changed according to ANSI C63.4: 2009 on conducted measurement.

Conducted emissions were investigated over the frequency range from 0.15MHz to 30MHz using a receiver bandwidth of 9kHz.

The EUT was setup to ANSI C63.4, 2009; tested to FHSS test procedure of FCC Public Notice DA 00-705 for compliance to FCC 47CFR 15.247 requirements.

2.5. Uncertainty

± 2.26 dB

2.6. Test Result of Conducted Emission

Product : Eee PC
 Test Item : Conducted Emission Test
 Power Line : Line 1
 Test Mode : Mode 2: Transmit - 3Mbps (8DPSK) (2441MHz)

Frequency MHz	Correct Factor dB	Reading Level dBuV	Measurement Level dBuV	Margin dB	Limit dBuV
LINE 1					
Quasi-Peak					
0.170	9.740	36.370	46.110	-19.319	65.429
0.236	9.682	27.500	37.182	-26.361	63.543
0.439	9.640	35.930	45.570	-12.173	57.743
0.884	9.670	26.290	35.960	-20.040	56.000
1.404	9.670	24.200	33.870	-22.130	56.000
17.771	9.980	26.340	36.320	-23.680	60.000
Average					
0.170	9.740	20.090	29.830	-25.599	55.429
0.236	9.682	16.640	26.322	-27.221	53.543
0.439	9.640	23.910	33.550	-14.193	47.743
0.884	9.670	14.720	24.390	-21.610	46.000
1.404	9.670	15.680	25.350	-20.650	46.000
17.771	9.980	20.730	30.710	-19.290	50.000

Note:

1. All Reading Levels are Quasi-Peak and average value.
2. "■" means the worst emission level.
3. Measurement Level = Reading Level + Correct Factor

Product : Eee PC
 Test Item : Conducted Emission Test
 Power Line : Line 2
 Test Mode : Mode 2: Transmit - 3Mbps (8DPSK) (2441MHz)

Frequency MHz	Correct Factor dB	Reading Level dBuV	Measurement Level dBuV	Margin dB	Limit dBuV
LINE 2					
Quasi-Peak					
0.177	9.736	36.490	46.226	-19.003	65.229
0.224	9.700	28.300	38.000	-25.886	63.886
0.353	9.655	27.600	37.255	-22.945	60.200
0.423	9.650	35.440	45.090	-13.110	58.200
1.127	9.670	24.830	34.500	-21.500	56.000
18.634	10.030	27.130	37.160	-22.840	60.000
Average					
0.177	9.736	21.990	31.726	-23.503	55.229
0.224	9.700	12.970	22.670	-31.216	53.886
0.353	9.655	19.650	29.305	-20.895	50.200
0.423	9.650	25.240	34.890	-13.310	48.200
1.127	9.670	15.710	25.380	-20.620	46.000
18.634	10.030	21.890	31.920	-18.080	50.000

Note:

1. All Reading Levels are Quasi-Peak and average value.
2. "■" means the worst emission level.
3. Measurement Level = Reading Level + Correct Factor

3. Peak Power Output

3.1. Test Equipment

	Equipment	Manufacturer	Model No./Serial No.	Last Cal.
X	Power Meter	Anritsu	ML2495A/6K00003357	May, 2011
X	Power Sensor	Anritsu	MA2411B/0738448	Jun, 2011

Note: 1. All equipments are calibrated every one year.
 2. The test instruments marked by “X” are used to measure the final test results.

3.2. Test Setup

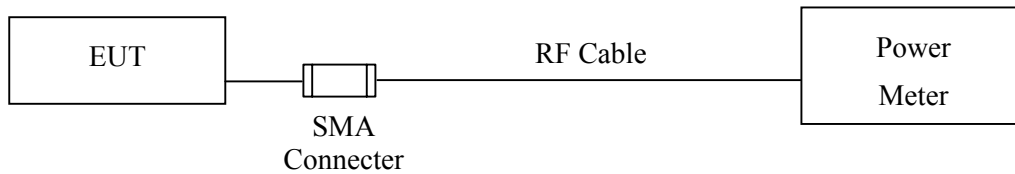

3.3. Limit

The maximum peak power shall be less 1Watt.

3.4. Test Procedure

The EUT was setup to ANSI C63.4, 2009; tested to FHSS test procedure of FCC Public Notice DA 00-705 for compliance to FCC 47CFR 15.247 requirements.

3.5. Uncertainty

± 1.27 dB

3.6. Test Result of Peak Power Output

Product : Eee PC
Test Item : Peak Power Output
Test Site : No.3 OATS
Test Mode : Mode 1: Transmit - 1Mbps (GFSK)

Channel No.	Frequency (MHz)	Measurement (dBm)	Required Limit	Result
Channel 00	2402.00	-2.38	1 Watt= 30 dBm	Pass
Channel 39	2441.00	-2.11	1 Watt= 30 dBm	Pass
Channel 78	2480.00	-1.95	1 Watt= 30 dBm	Pass

Product : Eee PC
Test Item : Peak Power Output
Test Site : No.3 OATS
Test Mode : Mode 2: Transmit - 3Mbps (8DPSK)

Channel No.	Frequency (MHz)	Measurement (dBm)	Required Limit	Result
Channel 00	2402.00	0.14	1 Watt= 30 dBm	Pass
Channel 39	2441.00	0.40	1 Watt= 30 dBm	Pass
Channel 78	2480.00	0.54	1 Watt= 30 dBm	Pass

4. Radiated Emission

4.1. Test Equipment

The following test equipments are used during the radiated emission test:

Test Site		Equipment	Manufacturer	Model No./Serial No.	Last Cal.
☒ Site # 3	X	Bilog Antenna	Schaffner Chase	CBL6112B/2673	Sep., 2010
	X	Horn Antenna	Schwarzbeck	BBHA9120D/D305	Sep., 2010
	X	Horn Antenna	Schwarzbeck	BBHA9170/208	Jul., 2011
	X	Pre-Amplifier	Agilent	8447D/2944A09549	Sep., 2010
	X	Spectrum Analyzer	Agilent	E4407B / US39440758	May, 2011
	X	Test Receiver	R & S	ESCS 30/ 825442/018	Sep., 2010
	X	Coaxial Cable	Quietek	QTK-CABLE/ CAB5	Feb., 2011
	X	Controller	Quietek	QTK-CONTROLLER/ CTRL3	N/A
	X	Coaxial Switch	Anritsu	MP59B/6200265729	N/A

- Note: 1. All equipments are calibrated every one year.
 2. The test instruments marked by "X" are used to measure the final test results.

4.2. Test Setup

Below 1GHz

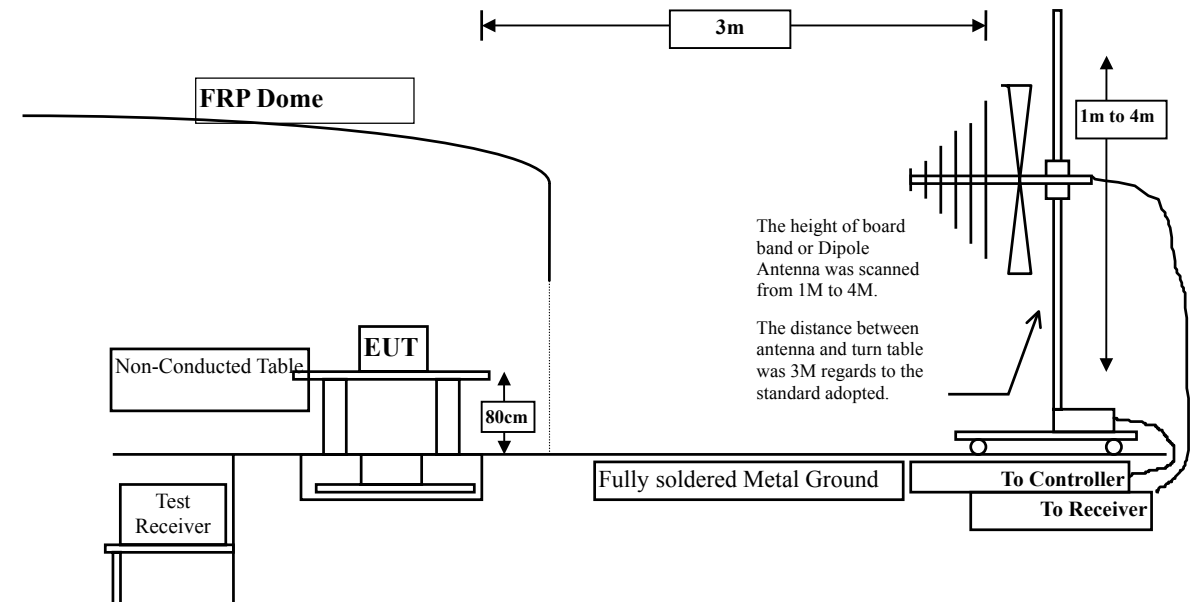

Above 1GHz

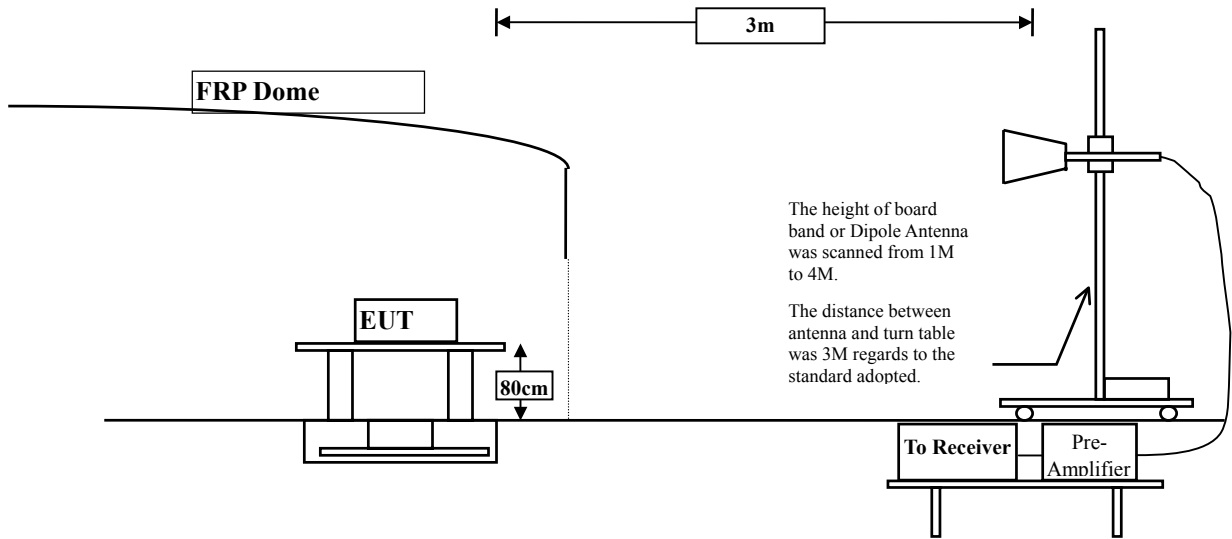

4.3. Limits

➤ General Radiated Emission Limits

Emissions radiated outside of the specified frequency bands, except for harmonics, shall be attenuated by at least 20dB below the level of the fundamental or to the general radiated emission limits in paragraph 15.209, whichever is the lesser attenuation.

FCC Part 15 Subpart C Paragraph 15.209 Limits		
Frequency MHz	uV/m @3m	dBuV/m@3m
30-88	100	40
88-216	150	43.5
216-960	200	46
Above 960	500	54

- Remarks:
1. RF Voltage (dBuV) = 20 log RF Voltage (uV)
 2. In the Above Table, the tighter limit applies at the band edges.
 3. Distance refers to the distance in meters between the measuring instrument antenna and the closed point of any part of the device or system.

4.4. Test Procedure

The EUT was setup according to ANSI C63.4, 2009 and tested according to FHSS test procedure of FCC Public Notice DA 00-705 for compliance to FCC 47CFR 15.247 requirements.

The EUT is placed on a turn table which is 0.8 meter above ground. The turn table is rotated 360 degrees to determine the position of the maximum emission level. The EUT was positioned such that the distance from antenna to the EUT was 3 meters.

The antenna is scanned from 1 meter to 4 meters to find out the maximum emission level. This is repeated for both horizontal and vertical polarization of the antenna. In order to find the maximum emission, all of the interface cables were manipulated according to ANSI C63.4:2009 on radiated measurement.

The resolution bandwidth below 1GHz setting on the field strength meter is 120 kHz and above 1GHz is 1MHz.

Radiated emission measurements below 1GHz are made using broadband Bilog antenna and above 1GHz are made using Horn Antennas.

The measurement is divided into the Preliminary Measurement and the Final Measurement.

The suspected frequencies are searched for in Preliminary Measurement with the measurement antenna kept pointed at the source of the emission both in azimuth and elevation, with the polarization of the antenna oriented for maximum response. The antenna is pointed at an angle towards the source of the emission, and the EUT is rotated in both height and polarization to maximize the measured emission. The emission is kept within the illumination area of the 3 dB bandwidth of the antenna.

The worst radiated emission is measured on the Final Measurement.

The measurement frequency range form 30MHz - 10th Harmonic of fundamental was investigated.

4.5. Uncertainty

± 3.9 dB above 1GHz

± 3.8 dB below 1GHz

4.6. Test Result of Radiated Emission

Product : Eee PC
 Test Item : Harmonic Radiated Emission
 Test Site : No.3 OATS
 Test Mode : Mode 1: Transmit - 1Mbps (GFSK)(2402MHz)

Frequency MHz	Correct Factor dB	Reading Level dBuV	Measurement Level dBuV/m	Margin dB	Limit dBuV/m
Horizontal					
Peak Detector:					
4804.000	3.327	37.770	41.097	-32.903	74.000
7206.000	10.136	36.710	46.846	-27.154	74.000
9608.000	13.706	35.990	49.696	-24.304	74.000
Average Detector:					
--					
Vertical					
Peak Detector:					
4804.000	6.638	36.660	43.297	-30.703	74.000
7206.000	11.005	35.920	46.925	-27.075	74.000
9608.000	14.103	35.940	50.043	-23.957	74.000
Average Detector:					
--					

Note:

1. All Readings below 1GHz are Quasi-Peak, above 1GHz are performed with peak and/or average measurements as necessary.
2. Peak measurements: RBW = 1MHz, VBW = 3 MHz, Sweep: Auto.
3. Average measurements: RBW = 1MHz, VBW = 10 Hz, Sweep: Auto.
4. Measurement Level = Reading Level + Correct Factor.
5. Correct Factor = Antenna factor + Cable loss – Amplifier gain.
6. The average measurement was not performed when the peak measured data under the limit of average detection.
7. The emission levels of other frequencies are very lower than the limit and not show in test report.

Product : Eee PC
 Test Item : Harmonic Radiated Emission
 Test Site : No.3 OATS
 Test Mode : Mode 1: Transmit - 1Mbps (GFSK)(2441MHz)

Frequency MHz	Correct Factor dB	Reading Level dBuV	Measurement Level dBuV/m	Margin dB	Limit dBuV/m
Horizontal					
Peak Detector:					
4882.000	3.001	36.910	39.911	-34.089	74.000
7323.000	11.846	34.890	46.737	-27.263	74.000
9764.000	12.563	36.280	48.843	-25.157	74.000
Average Detector:					
--					
Vertical					
Peak Detector:					
4882.000	5.713	37.280	42.994	-31.006	74.000
7323.000	12.727	35.310	48.038	-25.962	74.000
9764.000	13.028	36.310	49.338	-24.662	74.000
Average Detector:					
--					

Note:

1. All Readings below 1GHz are Quasi-Peak, above 1GHz are performed with peak and/or average measurements as necessary.
2. Peak measurements: RBW = 1MHz, VBW = 3 MHz, Sweep: Auto.
3. Average measurements: RBW = 1MHz, VBW = 10 Hz, Sweep: Auto.
4. Measurement Level = Reading Level + Correct Factor.
5. Correct Factor = Antenna factor + Cable loss – Amplifier gain.
6. The average measurement was not performed when the peak measured data under the limit of average detection.
7. The emission levels of other frequencies are very lower than the limit and not show in test report.

Product : Eee PC
 Test Item : Harmonic Radiated Emission
 Test Site : No.3 OATS
 Test Mode : Mode 1: Transmit - 1Mbps (GFSK)(2480MHz)

Frequency MHz	Correct Factor dB	Reading Level dBuV	Measurement Level dBuV/m	Margin dB	Limit dBuV/m
Horizontal					
Peak Detector:					
4960.000	2.760	36.740	39.500	-34.500	74.000
7440.000	12.567	34.540	47.106	-26.894	74.000
9920.000	13.456	35.580	49.036	-24.964	74.000
Average Detector:					
--					
Vertical					
Peak Detector:					
4960.000	5.557	36.760	42.317	-31.683	74.000
7440.000	13.426	34.630	48.055	-25.945	74.000
9920.000	13.958	36.150	50.108	-23.892	74.000
Average Detector:					
--					

Note:

1. All Readings below 1GHz are Quasi-Peak, above 1GHz are performed with peak and/or average measurements as necessary.
2. Peak measurements: RBW = 1MHz, VBW = 3 MHz, Sweep: Auto.
3. Average measurements: RBW = 1MHz, VBW = 10 Hz, Sweep: Auto.
4. Measurement Level = Reading Level + Correct Factor.
5. Correct Factor = Antenna factor + Cable loss – Amplifier gain.
6. The average measurement was not performed when the peak measured data under the limit of average detection.
7. The emission levels of other frequencies are very lower than the limit and not show in test report.

Product : Eee PC
 Test Item : Harmonic Radiated Emission
 Test Site : No.3 OATS
 Test Mode : Mode 2: Transmit - 3Mbps (8DPSK)(2402MHz)

Frequency MHz	Correct Factor dB	Reading Level dBuV	Measurement Level dBuV/m	Margin dB	Limit dBuV/m
Horizontal					
Peak Detector:					
4804.000	3.327	36.520	39.847	-34.153	74.000
7206.000	10.136	36.330	46.466	-27.534	74.000
9608.000	13.706	36.090	49.796	-24.204	74.000
Average Detector:					
--					
Vertical					
Peak Detector:					
4804.000	6.638	36.870	43.507	-30.493	74.000
7206.000	11.005	36.190	47.195	-26.805	74.000
9608.000	14.103	35.960	50.063	-23.937	74.000
Average Detector:					
--					

Note:

1. All Readings below 1GHz are Quasi-Peak, above 1GHz are performed with peak and/or average measurements as necessary.
2. Peak measurements: RBW = 1MHz, VBW = 3 MHz, Sweep: Auto.
3. Average measurements: RBW = 1MHz, VBW = 10 Hz, Sweep: Auto.
4. Measurement Level = Reading Level + Correct Factor.
5. Correct Factor = Antenna factor + Cable loss – Amplifier gain.
6. The average measurement was not performed when the peak measured data under the limit of average detection.
7. The emission levels of other frequencies are very lower than the limit and not show in test report.

Product : Eee PC
 Test Item : Harmonic Radiated Emission
 Test Site : No.3 OATS
 Test Mode : Mode 2: Transmit - 3Mbps (8DPSK) (2441MHz)

Frequency MHz	Correct Factor dB	Reading Level dBuV	Measurement Level dBuV/m	Margin dB	Limit dBuV/m
Horizontal					
Peak Detector:					
4882.000	3.001	37.120	40.121	-33.879	74.000
7323.000	11.846	35.170	47.017	-26.983	74.000
9764.000	12.563	35.840	48.403	-25.597	74.000
Average Detector:					
--					
Vertical					
Peak Detector:					
4882.000	5.713	37.710	43.424	-30.576	74.000
7323.000	12.727	35.350	48.078	-25.922	74.000
9764.000	13.028	36.050	49.078	-24.922	74.000
Average Detector:					
--					

Note:

1. All Readings below 1GHz are Quasi-Peak, above 1GHz are performed with peak and/or average measurements as necessary.
2. Peak measurements: RBW = 1MHz, VBW = 3 MHz, Sweep: Auto.
3. Average measurements: RBW = 1MHz, VBW = 10 Hz, Sweep: Auto.
4. Measurement Level = Reading Level + Correct Factor.
5. Correct Factor = Antenna factor + Cable loss – Amplifier gain.
6. The average measurement was not performed when the peak measured data under the limit of average detection.
7. The emission levels of other frequencies are very lower than the limit and not show in test report.

Product : Eee PC
 Test Item : Harmonic Radiated Emission
 Test Site : No.3 OATS
 Test Mode : Mode 2: Transmit - 3Mbps (8DPSK) (2480MHz)

Frequency MHz	Correct Factor dB	Reading Level dBuV	Measurement Level dBuV/m	Margin dB	Limit dBuV/m
Horizontal					
Peak Detector:					
4960.000	2.760	36.770	39.530	-34.470	74.000
7440.000	12.567	34.760	47.326	-26.674	74.000
9920.000	13.456	35.320	48.776	-25.224	74.000
Average Detector:					
--					
Vertical					
Peak Detector:					
4960.000	5.557	37.510	43.067	-30.933	74.000
7440.000	13.426	34.810	48.235	-25.765	74.000
9920.000	13.958	35.850	49.808	-24.192	74.000
Average Detector:					
--					

Note:

1. All Readings below 1GHz are Quasi-Peak, above 1GHz are performed with peak and/or average measurements as necessary.
2. Peak measurements: RBW = 1MHz, VBW = 3 MHz, Sweep: Auto.
3. Average measurements: RBW = 1MHz, VBW = 10 Hz, Sweep: Auto.
4. Measurement Level = Reading Level + Correct Factor.
5. Correct Factor = Antenna factor + Cable loss – Amplifier gain.
6. The average measurement was not performed when the peak measured data under the limit of average detection.
7. The emission levels of other frequencies are very lower than the limit and not show in test report.

Product : Eee PC
 Test Item : General Radiated Emission
 Test Site : No.3 OATS
 Test Mode : Mode 1: Transmit - 1Mbps (GFSK) (2441MHz)

Frequency MHz	Correct Factor dB	Reading Level dBuV	Measurement Level dBuV/m	Margin dB	Limit dBuV/m
Horizontal					
57.160	-13.583	45.492	31.909	-8.091	40.000
95.960	-7.820	38.346	30.526	-12.974	43.500
348.160	-2.268	37.590	35.322	-10.678	46.000
600.360	3.977	31.194	35.171	-10.829	46.000
875.840	5.271	28.010	33.281	-12.719	46.000
1000.000	9.119	28.112	37.231	-16.769	54.000
Vertical					
37.760	-1.539	37.161	35.622	-4.378	40.000
97.900	-1.400	35.542	34.141	-9.359	43.500
352.040	-3.833	39.266	35.433	-10.567	46.000
528.580	-0.462	31.436	30.974	-15.026	46.000
825.400	3.430	26.971	30.401	-15.599	46.000
949.560	6.615	26.415	33.030	-12.970	46.000

Note:

1. All Readings below 1GHz are Quasi-Peak, above 1GHz are performed with peak and/or average measurements as necessary.
2. Peak measurements: RBW = 1MHz, VBW = 3 MHz, Sweep: Auto.
3. Average measurements: RBW = 1MHz, VBW = 10 Hz, Sweep: Auto.
4. Measurement Level = Reading Level + Correct Factor.
5. Correct Factor = Antenna factor + Cable loss – Amplifier gain.
6. The average measurement was not performed when the peak measured data under the limit of average detection.
7. The emission levels of other frequencies are very lower than the limit and not show in test report.

Product : Eee PC
 Test Item : General Radiated Emission
 Test Site : No.3 OATS
 Test Mode : Mode 2: Transmit - 3Mbps (8DPSK) (2441MHz)

Frequency MHz	Correct Factor dB	Reading Level dBuV	Measurement Level dBuV/m	Margin dB	Limit dBuV/m
Horizontal					
59.100	-14.047	46.361	32.314	-7.686	40.000
348.160	-2.268	38.103	35.835	-10.165	46.000
466.500	0.794	33.451	34.244	-11.756	46.000
600.360	3.977	30.204	34.181	-11.819	46.000
875.840	5.271	29.533	34.804	-11.196	46.000
1000.000	9.119	29.469	38.588	-15.412	54.000
Vertical					
66.860	-6.015	41.681	35.666	-4.334	40.000
97.900	-1.400	35.646	34.245	-9.255	43.500
352.040	-3.833	38.267	34.434	-11.566	46.000
528.580	-0.462	31.800	31.338	-14.662	46.000
697.360	1.311	31.170	32.481	-13.519	46.000
951.500	6.621	27.351	33.972	-12.028	46.000

Note:

1. All Readings below 1GHz are Quasi-Peak, above 1GHz are performed with peak and/or average measurements as necessary.
2. Peak measurements: RBW = 1MHz, VBW = 3 MHz, Sweep: Auto.
3. Average measurements: RBW = 1MHz, VBW = 10 Hz, Sweep: Auto.
4. Measurement Level = Reading Level + Correct Factor.
5. Correct Factor = Antenna factor + Cable loss – Amplifier gain.
6. The average measurement was not performed when the peak measured data under the limit of average detection.
7. The emission levels of other frequencies are very lower than the limit and not show in test report.

5. RF Antenna Conducted Test

5.1. Test Equipment

	Equipment	Manufacturer	Model No./Serial No.	Last Cal.
X	Spectrum Analyzer	R&S	FSP40 / 100170	Jun, 2011
	Spectrum Analyzer	Agilent	E4407B / US39440758	Jun, 2011
	Spectrum Analyzer	Agilent	N9010A / MY48030495	Apr., 2011

Note: 1. All equipments are calibrated every one year.
 2. The test instruments Marked “X” are used to measure the final test results.

5.2. Test Setup

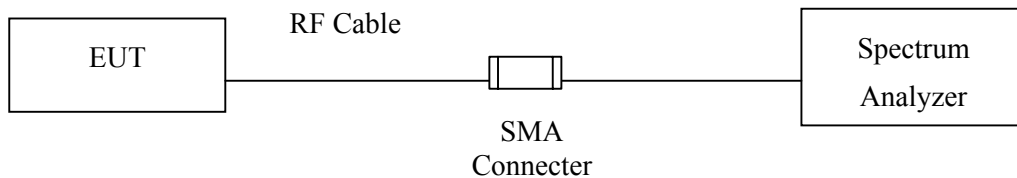

5.3. Limits

According to FCC Section 15.247(d). In any 100 kHz bandwidth outside the frequency band in which the spread spectrum or digitally modulated intentional radiator is operating, the radio frequency power that is produced by the intentional radiator shall be at least 20 dB below that in the 100 kHz bandwidth within the band that contains the highest level of the desired power, based on either an RF conducted or measurement, provided the transmitter demonstrates compliance with the peak conducted power limits. If the transmitter complies with the conducted power limits based on the use of RMS averaging over a time interval, the attenuation required under this paragraph shall be 30 dB instead of 20 dB.

5.4. Test Procedure

The EUT was setup to ANSI C63.4, 2009; tested to FHSS test procedure of FCC Public Notice DA 00-705 for compliance to FCC 47CFR 15.247 requirements.

5.5. Uncertainty

± 150Hz

5.6. Test Result of RF Antenna Conducted Test

Product : Eee PC
 Test Item : RF Antenna Conducted Test
 Test Site : No.3 OATS
 Test Mode : Mode 1: Transmit - 1Mbps (GFSK)

Figure Channel 00:

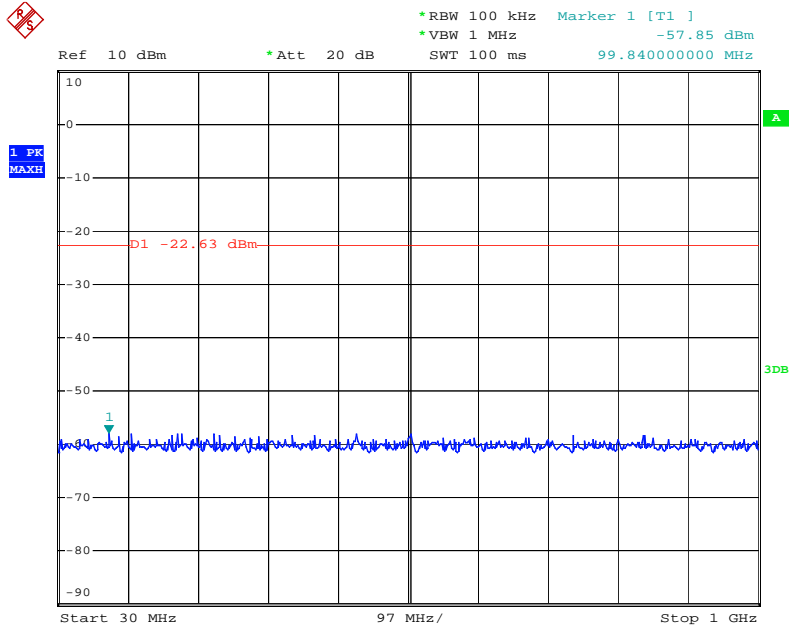

Date: 24.JUN.2011 14:00:49

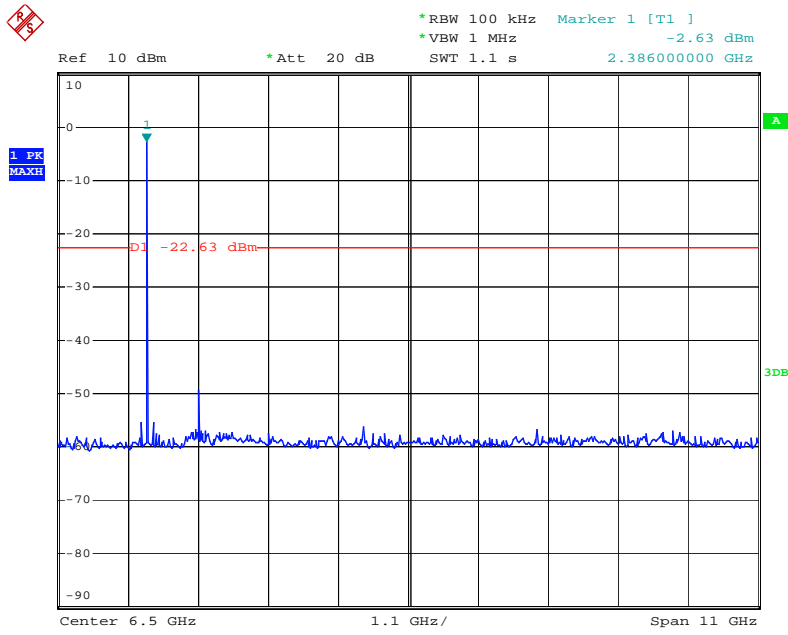

Date: 24.JUN.2011 13:59:52

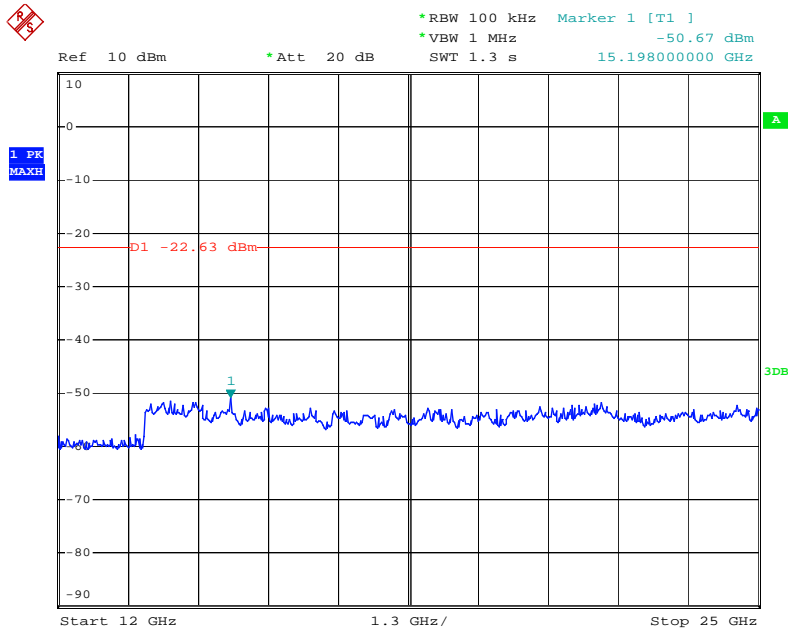

Date: 24.JUN.2011 14:00:31

Product : Eee PC
Test Item : RF Antenna Conducted Test
Test Site : No.3 OATS
Test Mode : Mode 1: Transmit - 1Mbps (GFSK)

Figure Channel 39:

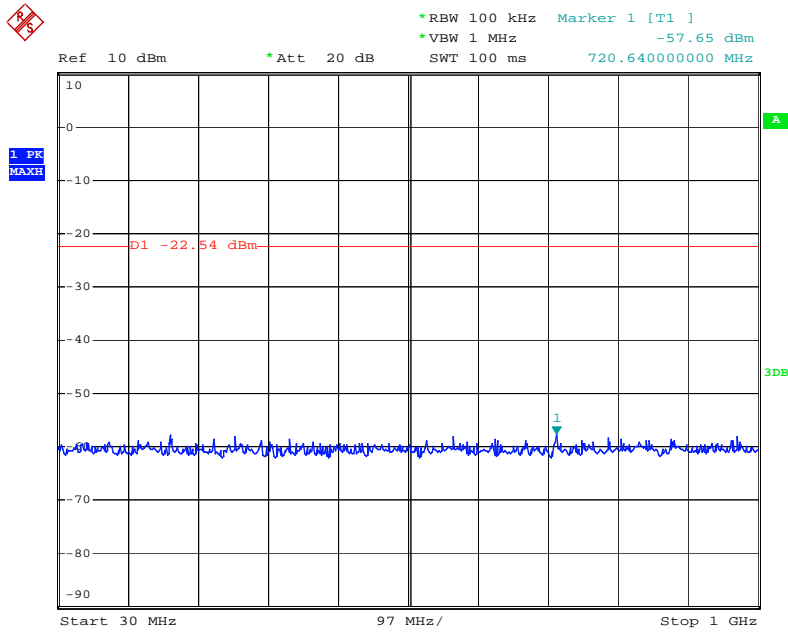

Date: 24.JUN.2011 14:02:08

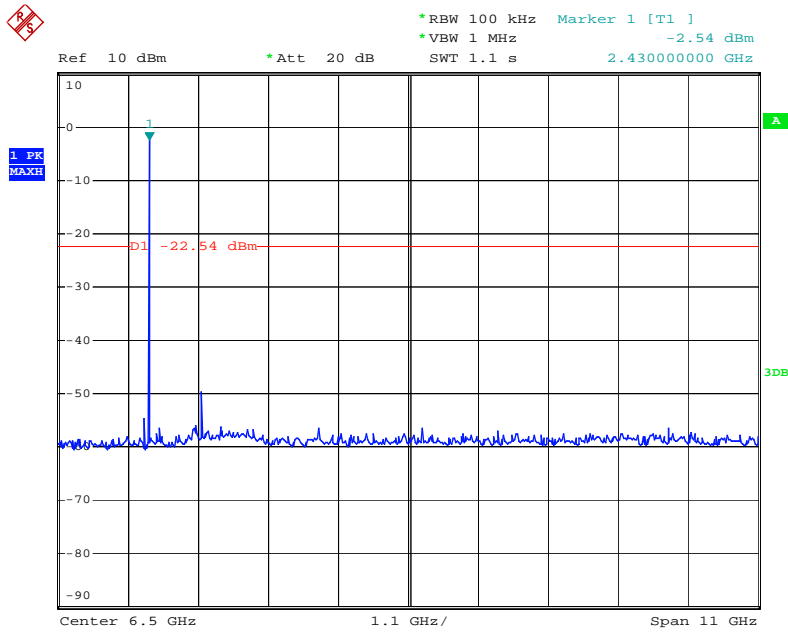

Date: 24.JUN.2011 14:01:39

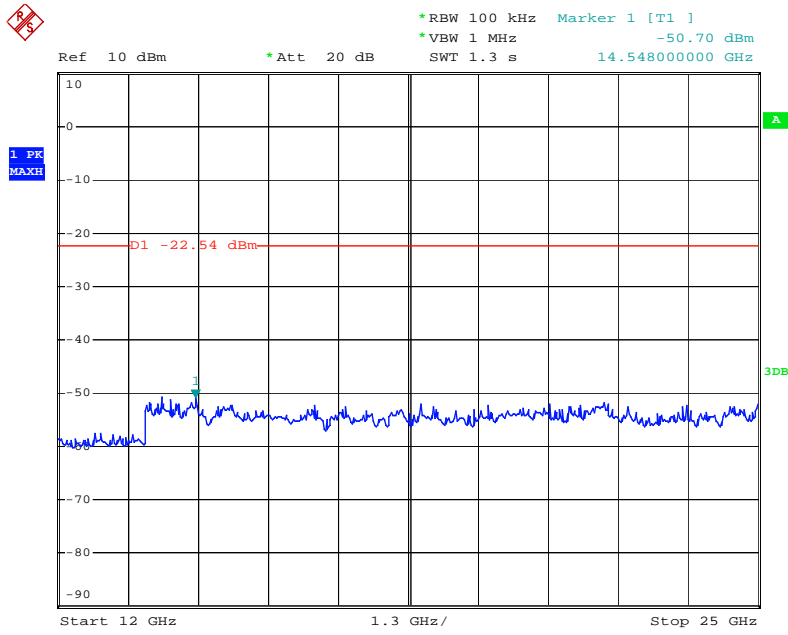

Date: 24.JUN.2011 14:01:57

Product : Eee PC
Test Item : RF Antenna Conducted Test
Test Site : No.3 OATS
Test Mode : Mode 1: Transmit - 1Mbps (GFSK)

Figure Channel 78:

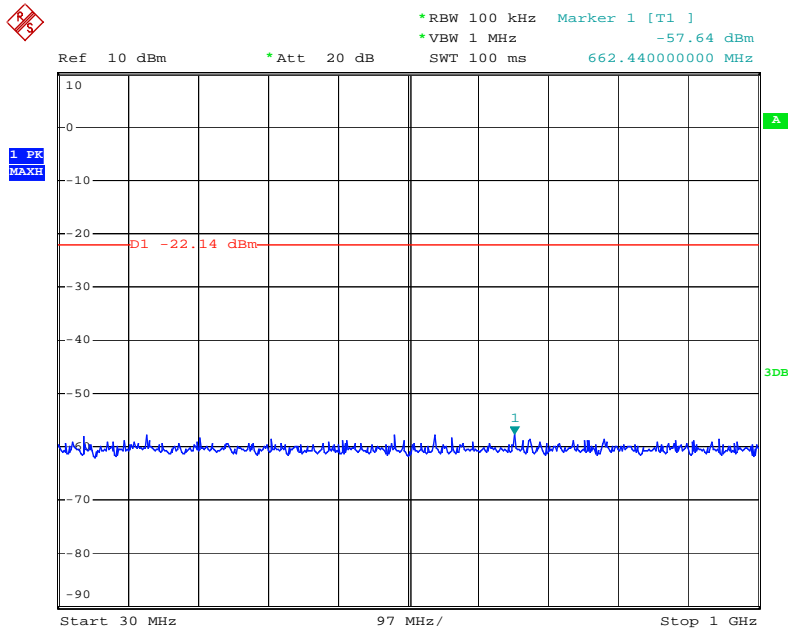

Date: 24.JUN.2011 14:03:45

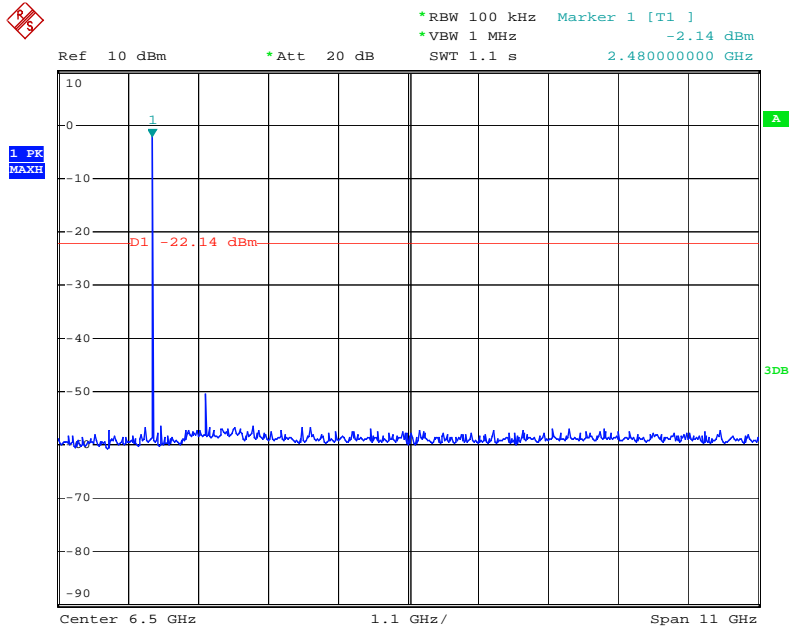

Date: 24.JUN.2011 14:03:14

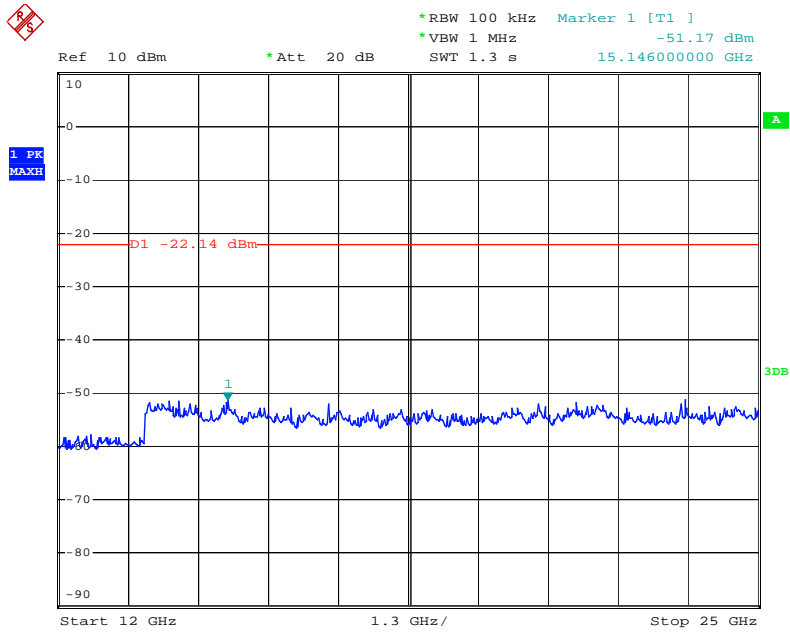

Date: 24.JUN.2011 14:03:32

Product : Eee PC
Test Item : RF Antenna Conducted Test
Test Site : No.3 OATS
Test Mode : Mode 2: Transmit - 3Mbps (8DPSK)

Figure Channel 00:

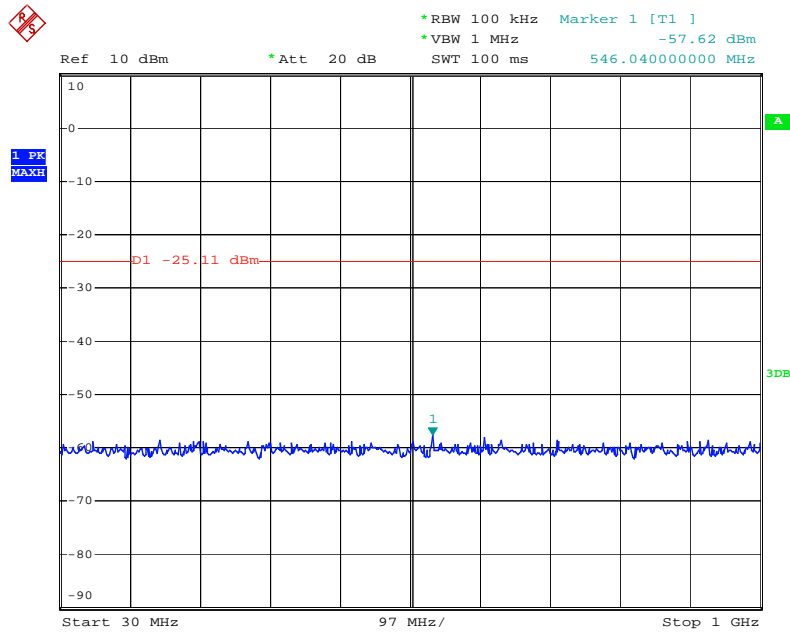

Date: 24.JUN.2011 14:09:37

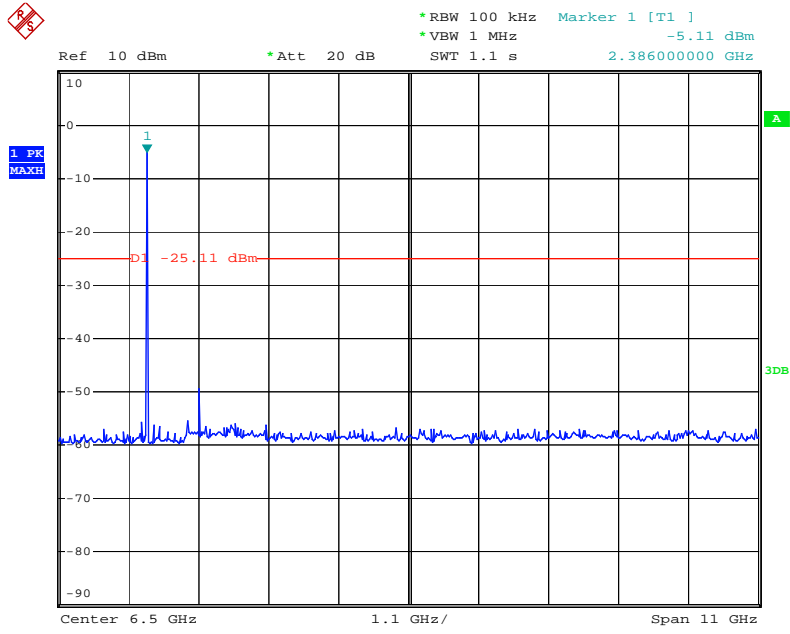

Date: 24.JUN.2011 14:09:06

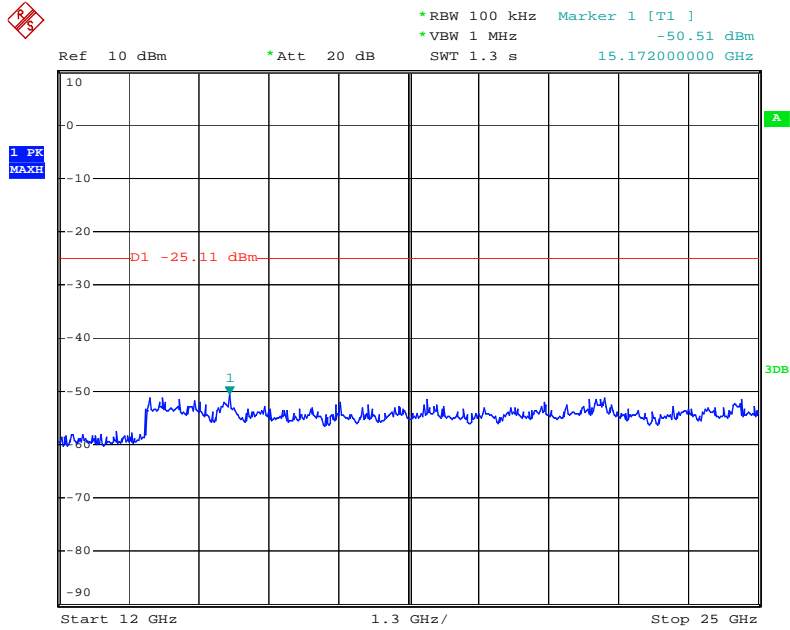

Date: 24.JUN.2011 14:09:25

Product : Eee PC
Test Item : RF Antenna Conducted Test
Test Site : No.3 OATS
Test Mode : Mode 2: Transmit - 3Mbps (8DPSK)

Figure Channel 39:

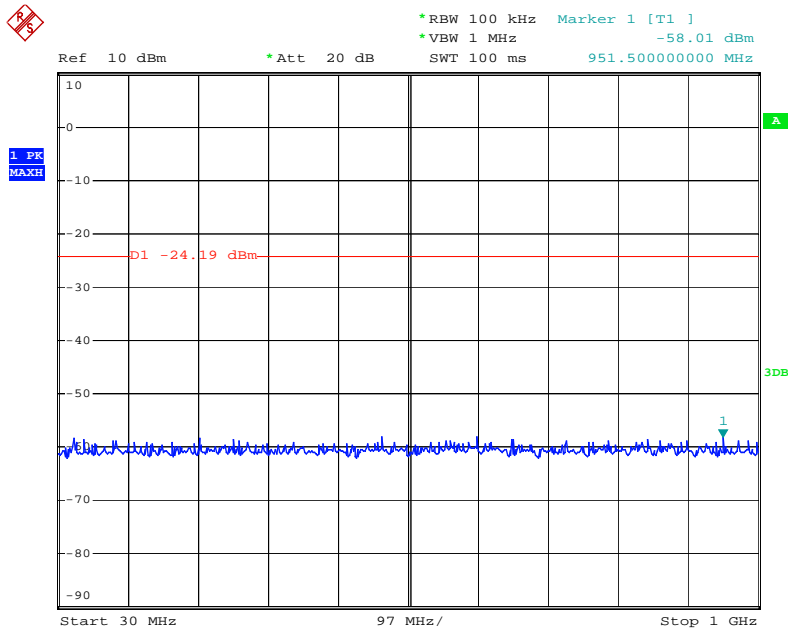

Date: 24.JUN.2011 14:07:40

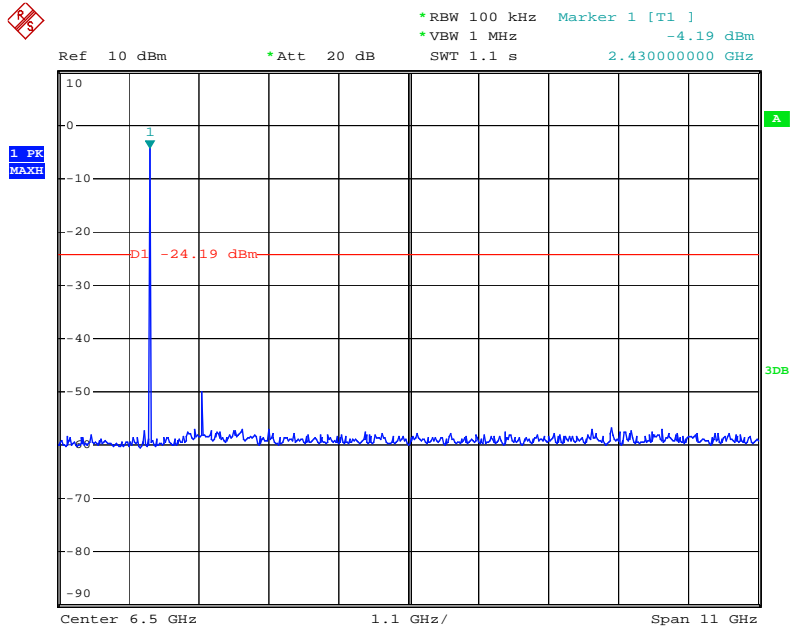

Date: 24.JUN.2011 14:07:05

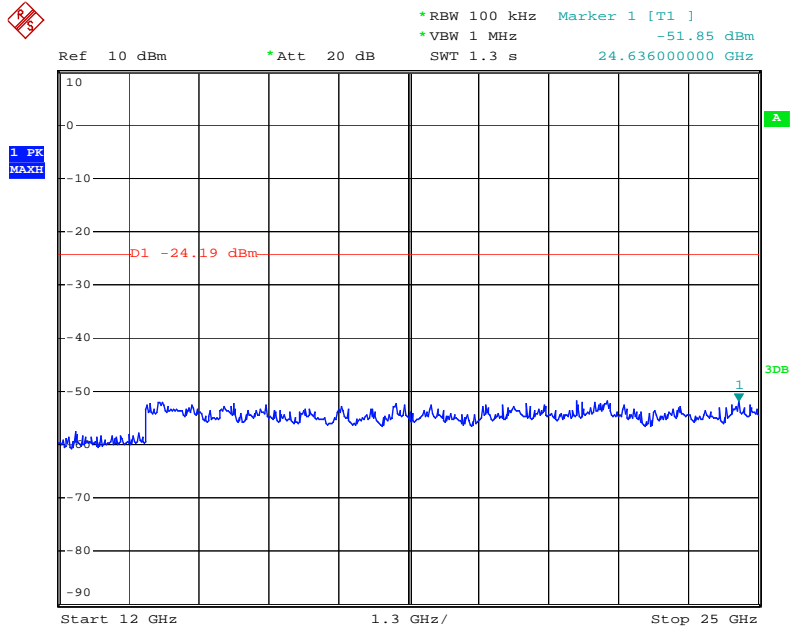

Date: 24.JUN.2011 14:07:25

Product : Eee PC
Test Item : RF Antenna Conducted Test
Test Site : No.3 OATS
Test Mode : Mode 2: Transmit - 3Mbps (8DPSK)

Figure Channel 78:

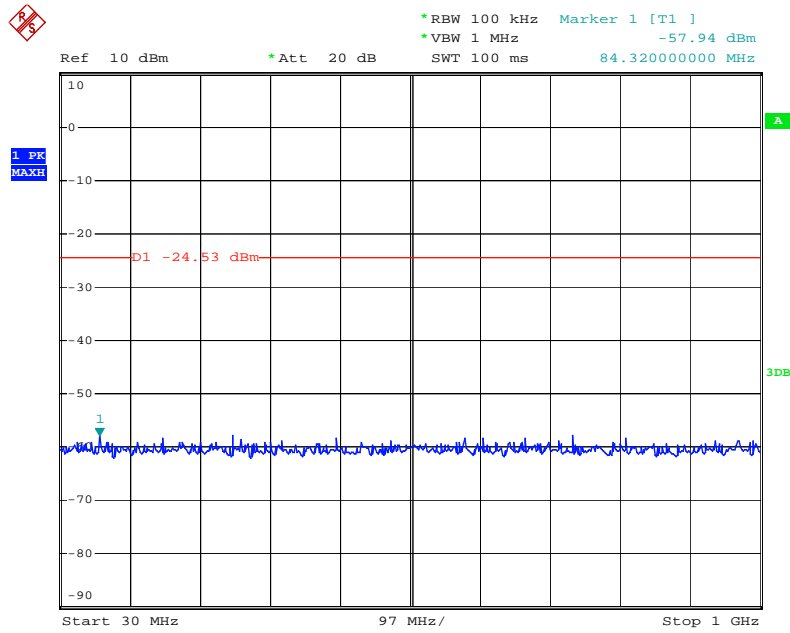

Date: 24.JUN.2011 14:04:57

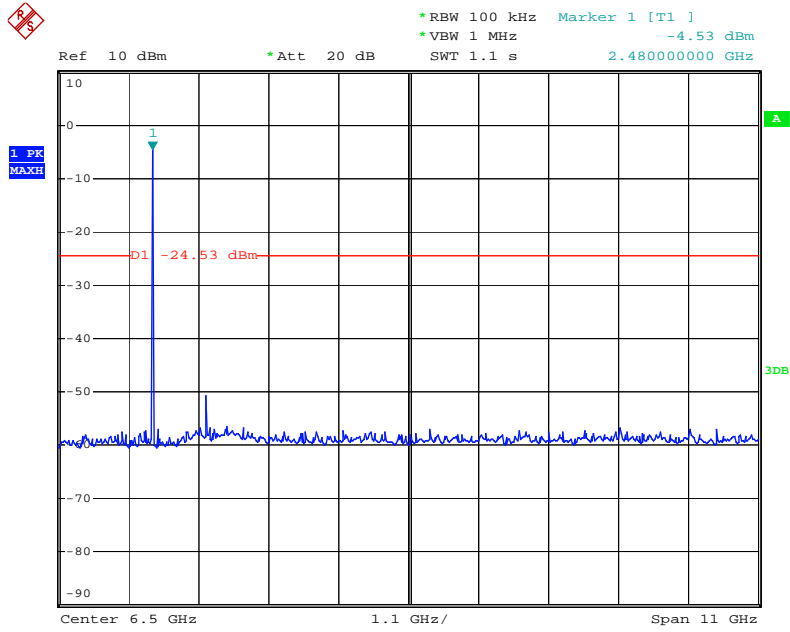

Date: 24.JUN.2011 14:04:25

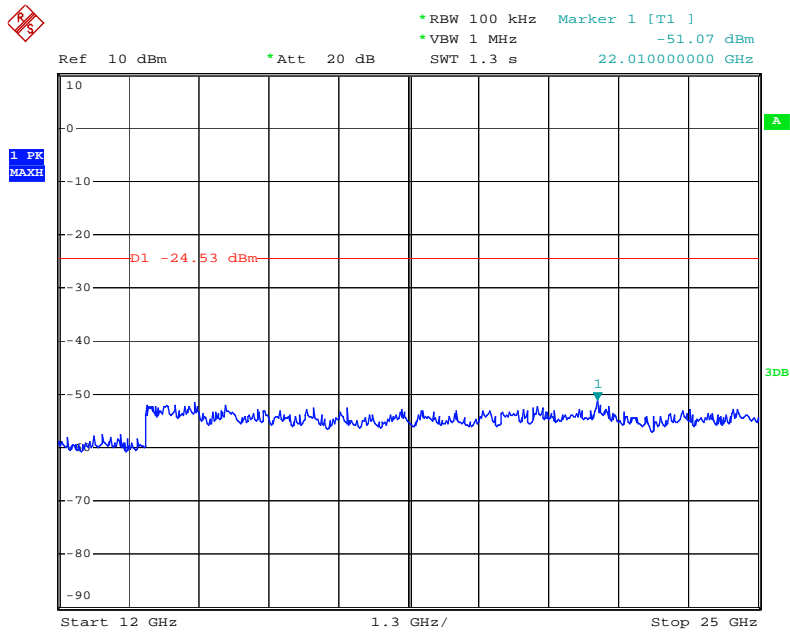

Date: 24.JUN.2011 14:04:43

6. Band Edge

6.1. Test Equipment

RF Conducted Measurement

The following test equipments are used during the band edge tests:

	Equipment	Manufacturer	Model No./Serial No.	Last Cal.
	Spectrum Analyzer	R&S	FSP40 / 100170	Jun, 2011
	Spectrum Analyzer	Agilent	E4407B / US39440758	Jun, 2011
X	Spectrum Analyzer	Agilent	N9010A / MY48030495	Apr., 2011

RF Radiated Measurement:

The following test equipments are used during the band edge tests:

Test Site		Equipment	Manufacturer	Model No./Serial No.	Last Cal.
☒ Site # 3		Bilog Antenna	Schaffner Chase	CBL6112B/2673	Sep., 2010
	X	Horn Antenna	Schwarzbeck	BBHA9120D/D305	Sep., 2010
		Horn Antenna	Schwarzbeck	BBHA9170/208	Jul., 2011
	X	Pre-Amplifier	Agilent	8447D/2944A09549	Sep., 2010
	X	Spectrum Analyzer	Agilent	E4407B / US39440758	May, 2011
		Test Receiver	R & S	ESCS 30/ 825442/018	Sep., 2010
	X	Coaxial Cable	Quietek	QTK-CABLE/ CAB5	Feb., 2011
	X	Controller	Quietek	QTK-CONTROLLER/ CTRL3	N/A
	X	Coaxial Switch	Anritsu	MP59B/6200265729	N/A

- Note:
1. All equipments are calibrated every one year.
 2. The test instruments marked by "X" are used to measure the final test results.

6.2. Test Setup

RF Conducted Measurement

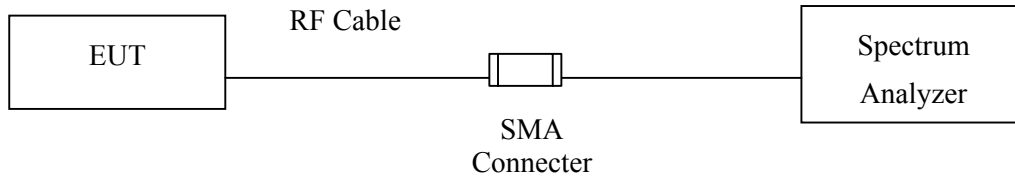

RF Radiated Measurement:

Above 1GHz

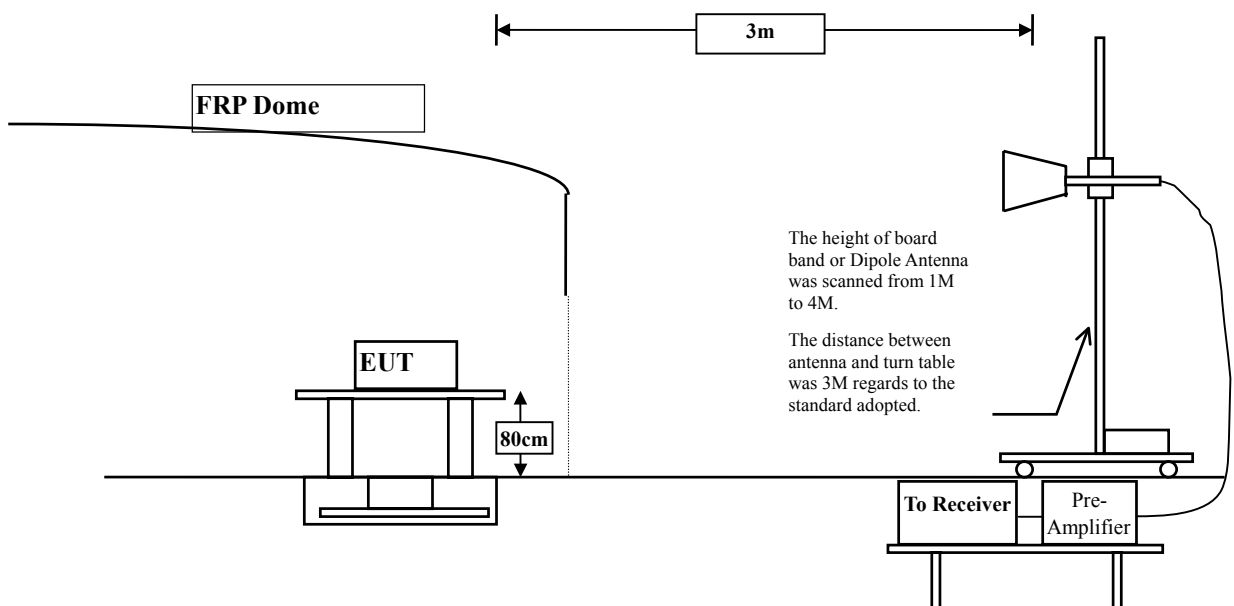

6.3. Limit

In any 100 kHz bandwidth outside the frequency band in which the spread spectrum intentional radiator is operating, the radio frequency power that is produced by the intentional radiator shall be at least 20 dB below that in the 100 kHz bandwidth within the band that contains the highest level of the desired power, based on either an RF conducted or a radiated measurement. Attenuation below the general limits specified in Section 15.209(a) is not required. In addition, radiated emissions which fall in the restricted bands, as defined in Section 15.205(a), must also comply with the radiated emission limits specified in Section 15.209(a) (see Section 15.205(c)).

6.4. Test Procedure

The EUT and its simulators are placed on a turn table which is 0.8 meter above ground. The turn table can rotate 360 degrees to determine the position of the maximum emission level. The EUT was positioned such that the distance from antenna to the EUT was 3 meters.

The antenna can move up and down between 1 meter and 4 meters to find out the maximum emission level.

Both horizontal and vertical polarization of the antenna are set on measurement. In order to find the maximum emission, all of the interface cables must be manipulated according to ANSI C63.4:2009 on radiated measurement.

The bandwidth below 1GHz setting on the field strength meter is 120 kHz, above 1GHz are 1 MHz. The EUT was setup to ANSI C63.4, 2009; tested to FHSS test procedure of FCC Public Notice DA 00-705 for compliance to FCC 47CFR 15.247 requirements.

6.5. Uncertainty

± 3.9 dB above 1GHz

± 3.8 dB below 1GHz

6.6. Test Result of Band Edge

Product : Eee PC
 Test Item : Band Edge
 Test Site : No.3 OATS
 Test Mode : Mode 1: Transmit - 1Mbps (GFSK)

Fundamental Filed Strength

Antenna Pole	Frequency [MHz]	Correction Factor [dB/m]	Reading Level [dBuV]	Emission Level [dBuV/m]	Detector
Horizontal	2402	31.573	54.72	86.294	Peak
Horizontal	2402	31.573	44.49	76.064	Average
Vertical	2402	31.573	59.21	90.784	Peak
Vertical	2402	31.573	48.3	79.874	Average

Note: 1:Spectrum Analyzer setting:

Peak detector: RBW=1MHz, VBW=1MHz

Average detector: RBW=1MHz, VBW=10Hz

Band Edge Test Data

Antenna Pole	Test Frequency (MHz)	Fundamental (dBuV/m)	Δ (dB)	Band Edge Field Strength (dBuV/m)	Limit (dBuV/m)	Detector
Horizontal	2381.7	86.294	50.649	35.645	74.000	Peak
Horizontal	2382	76.064	46.692	29.372	54.000	Average
Vertical	2381.7	90.784	50.649	40.135	74.000	Peak
Vertical	2382	79.874	46.692	33.182	54.000	Average

Note:

The Band Edge Field Strength was calculated using the Fundamental and Conducted Band Edge measurements per the Marker-Delta Method with the following formula:

Band Edge field Strength = F - Δ

F = Fundamental field Strength (Peak or Average)

Δ = Conducted Band Edge Delta (Peak or Average)

Peak Detector of conducted Band Edge Delta

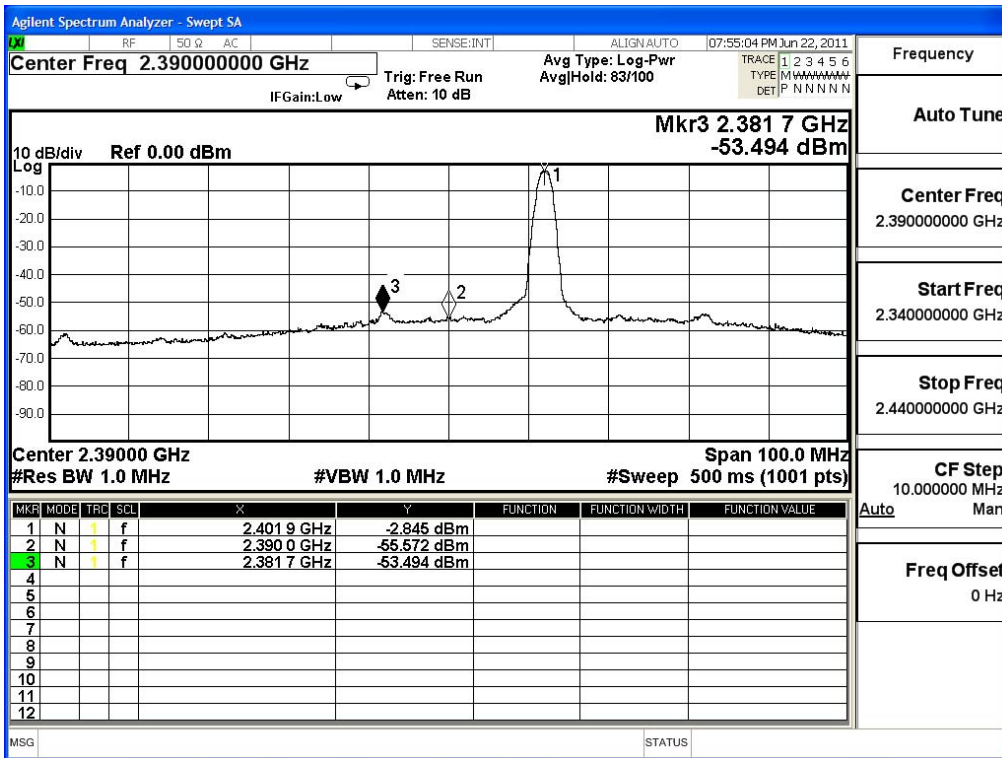

Average Detector of conducted Band Edge Delta

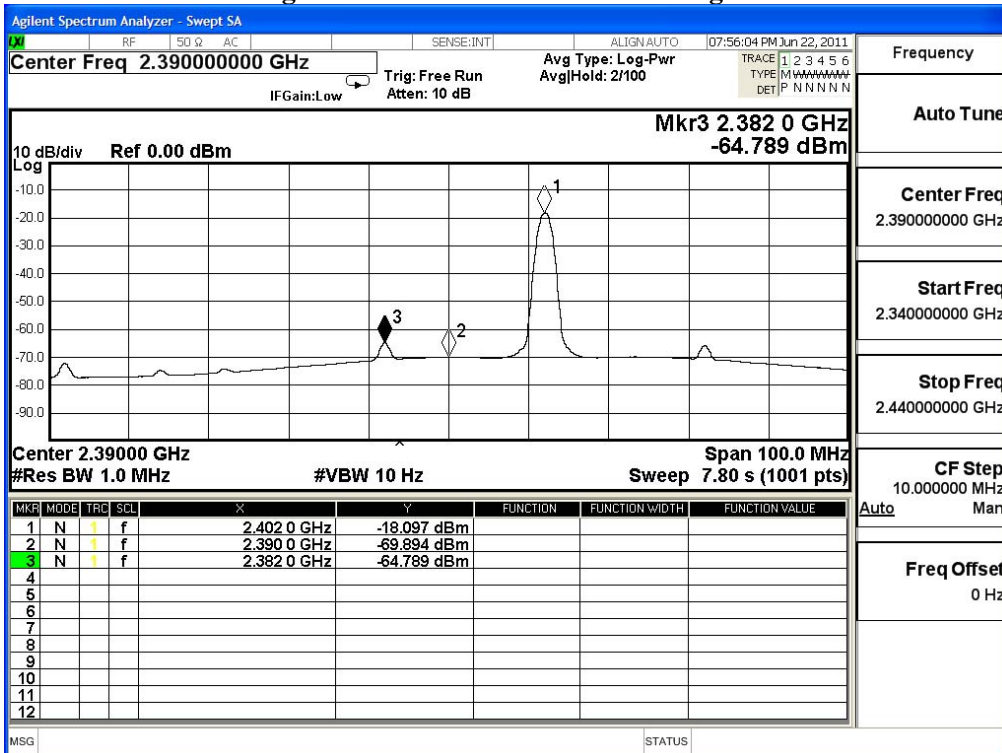

Product : Eee PC
 Test Item : Band Edge
 Test Site : No.3 OATS
 Test Mode : Mode 1: Transmit - 1Mbps (GFSK)

Fundamental Filed Strength

Antenna Pole	Frequency [MHz]	Correction Factor [dB/m]	Reading Level [dBuV]	Emission Level [dB(uV/m)]	Detector
Horizontal	2480	32.155	54.5	86.656	Peak
Horizontal	2480	32.155	44.54	76.696	Average
Vertical	2480	31.412	58.82	90.232	Peak
Vertical	2480	31.412	47.99	79.402	Average

Note: 1:Spectrum Analyzer setting:

Peak detector: RBW=1MHz, VBW=1MHz

Average detector: RBW=1MHz, VBW=10Hz

Band Edge Test Data

Antenna Pole	Test Frequency (MHz)	Fundamental (dBuV/m)	Δ (dB)	Band Edge Field Strength (dBuV/m)	Limit (dBuV/m)	Detector
Horizontal	2483.5	86.656	49.944	36.712	74.000	Peak
Horizontal	2500	76.696	49.018	27.678	54.000	Average
Vertical	2483.5	90.232	49.944	40.288	74.000	Peak
Vertical	2500	79.402	49.018	30.384	54.000	Average

Note:

The Band Edge Field Strength was calculated using the Fundamental and Conducted Band Edge measurements per the Marker-Delta Method with the following formula:

Band Edge field Strength = F - Δ

F = Fundamental field Strength (Peak or Average)

Δ = Conducted Band Edge Delta (Peak or Average)

Peak Detector of conducted Band Edge Delta

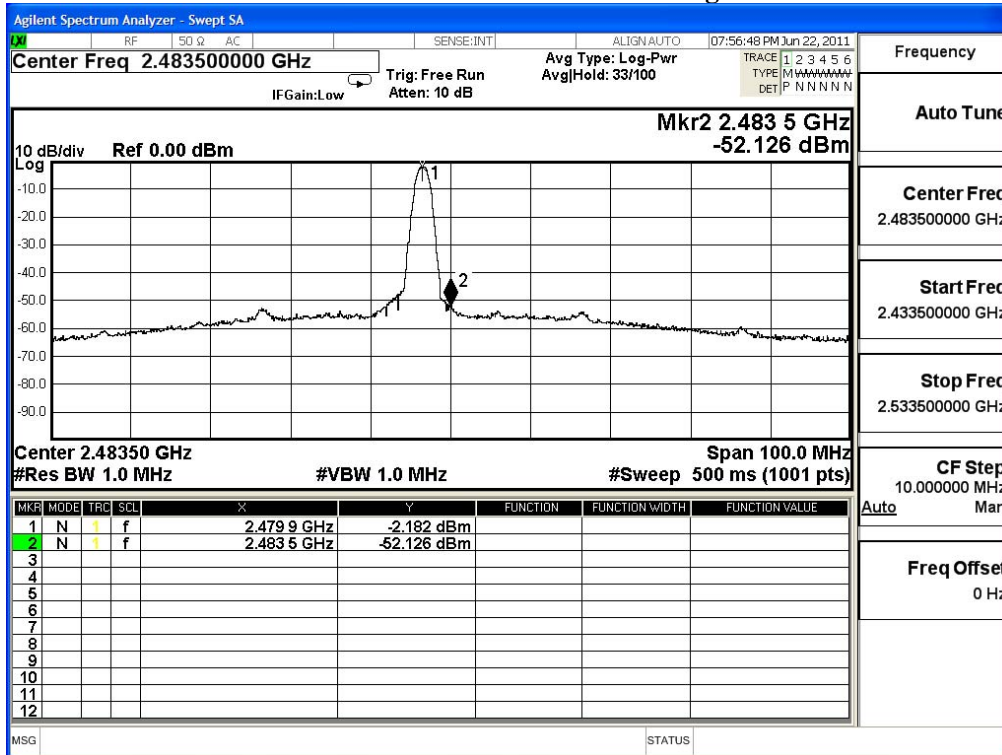

Average Detector of conducted Band Edge Delta

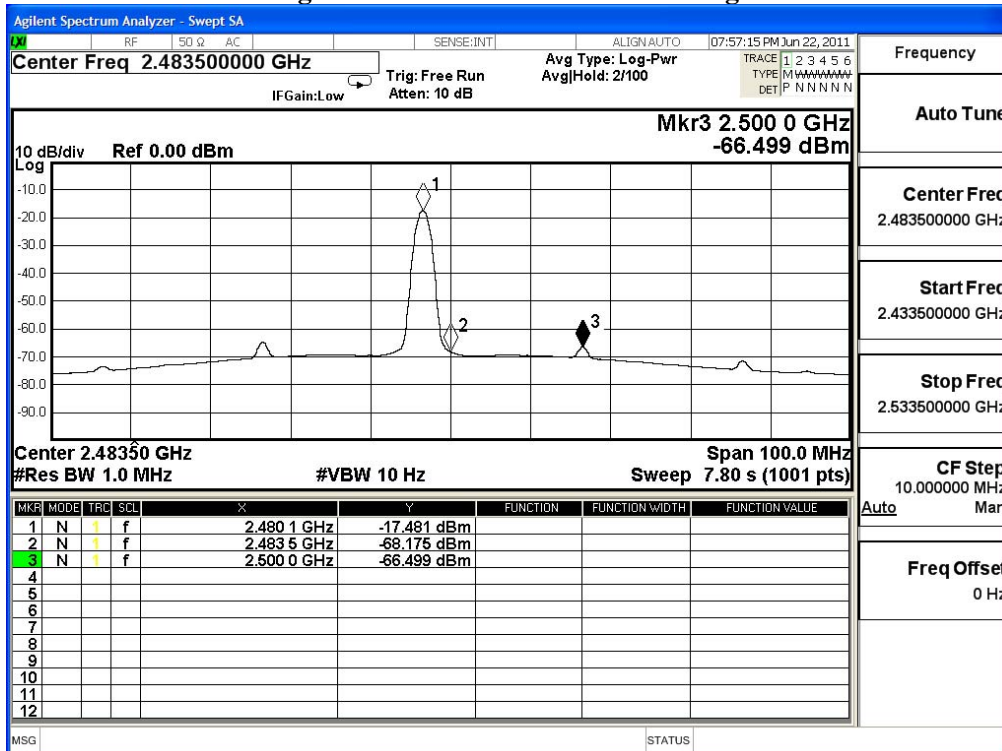

Product : Eee PC
 Test Item : Band Edge
 Test Site : No.3 OATS
 Test Mode : Mode 2: Transmit - 3Mbps (8DPSK)

Fundamental Filed Strength

Antenna Pole	Frequency [MHz]	Correction Factor [dB/m]	Reading Level [dBuV]	Emission Level [dBuV/m]	Detector
Horizontal	2402	31.573	56.4	87.974	Peak
Horizontal	2402	31.573	43.31	74.884	Average
Vertical	2402	30.917	60.95	91.867	Peak
Vertical	2402	30.917	47.13	78.047	Average

Note: 1:Spectrum Analyzer setting:

Peak detector: RBW=1MHz, VBW=1MHz

Average detector: RBW=1MHz, VBW=10Hz

Band Edge Test Data

Antenna Pole	Test Frequency (MHz)	Fundamental (dBuV/m)	Δ (dB)	Band Edge Field Strength (dBuV/m)	Limit (dBuV/m)	Detector
Horizontal	2382.1	87.974	50.007	37.967	74.000	Peak
Horizontal	2382	74.884	45.596	29.288	54.000	Average
Vertical	2382.1	91.867	50.007	41.86	74.000	Peak
Vertical	2382	78.047	45.596	32.451	54.000	Average

Note:

The Band Edge Field Strength was calculated using the Fundamental and Conducted Band Edge measurements per the Marker-Delta Method with the following formula:

Band Edge field Strength = F - Δ

F = Fundamental field Strength (Peak or Average)

Δ = Conducted Band Edge Delta (Peak or Average)

Peak Detector of conducted Band Edge Delta

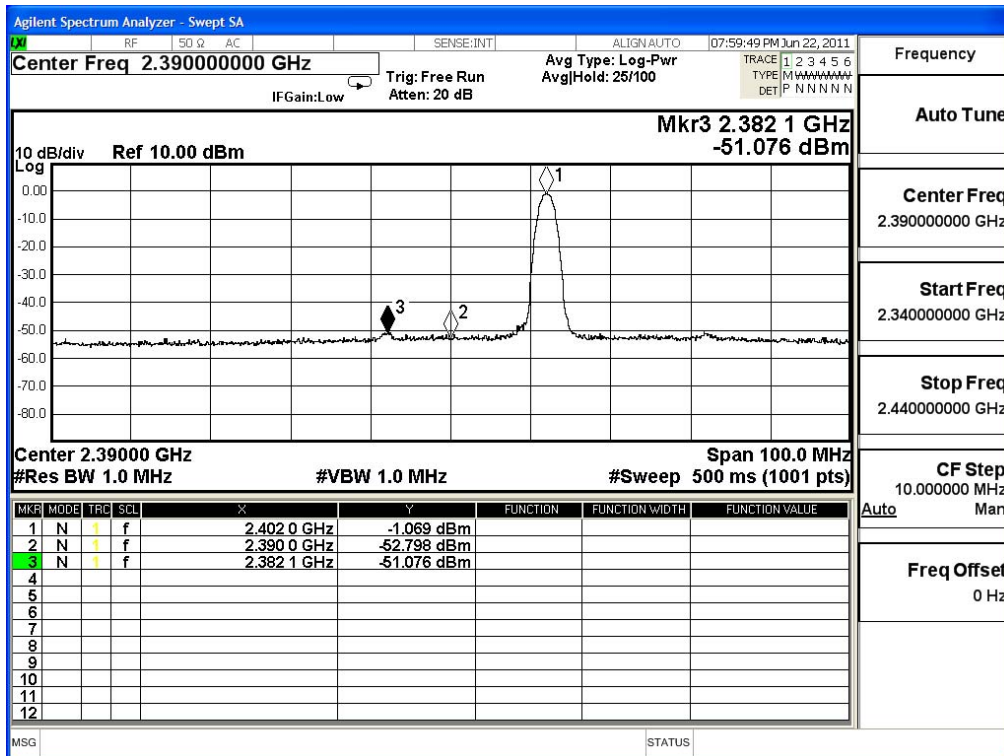

Average Detector of conducted Band Edge Delta

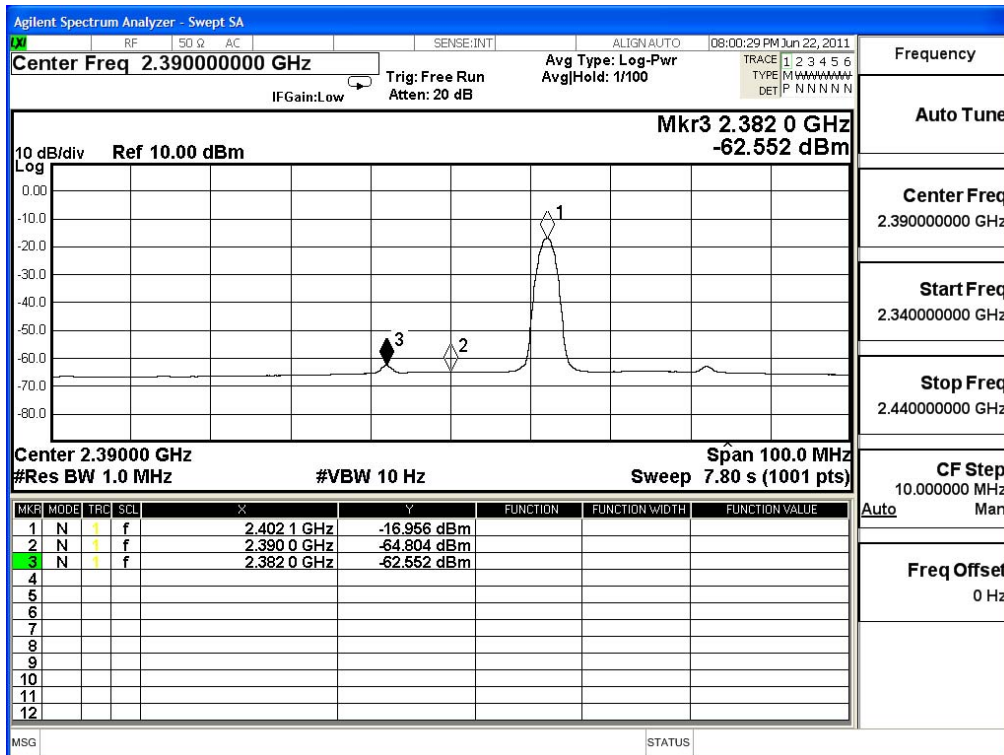

Product : Eee PC
 Test Item : Band Edge
 Test Site : No.3 OATS
 Test Mode : Mode 2: Transmit - 3Mbps (8DPSK)

Fundamental Filed Strength

Antenna Pole	Frequency [MHz]	Correction Factor [dB/m]	Reading Level [dBuV]	Emission Level [dB(uV/m)]	Detector
Horizontal	2480	32.155	56.17	88.326	Peak
Horizontal	2480	32.155	43.36	75.516	Average
Vertical	2480	31.412	60.59	92.002	Peak
Vertical	2480	31.412	47.01	78.422	Average

Note: 1:Spectrum Analyzer setting:

Peak detector: RBW=1MHz, VBW=1MHz

Average detector: RBW=1MHz, VBW=10Hz

Band Edge Test Data

Antenna Pole	Test Frequency (MHz)	Fundamental (dBuV/m)	Δ (dB)	Band Edge Field Strength (dBuV/m)	Limit (dBuV/m)	Detector
Horizontal	2496.8	88.326	50.571	37.755	74.000	Peak
Horizontal	2500	75.516	46.628	28.888	54.000	Average
Vertical	2496.8	92.002	50.571	41.431	74.000	Peak
Vertical	2500	78.422	46.628	31.794	54.000	Average

Note:

The Band Edge Field Strength was calculated using the Fundamental and Conducted Band Edge measurements per the Marker-Delta Method with the following formula:

Band Edge field Strength = F - Δ

F = Fundamental field Strength (Peak or Average)

Δ = Conducted Band Edge Delta (Peak or Average)

Peak Detector of conducted Band Edge Delta

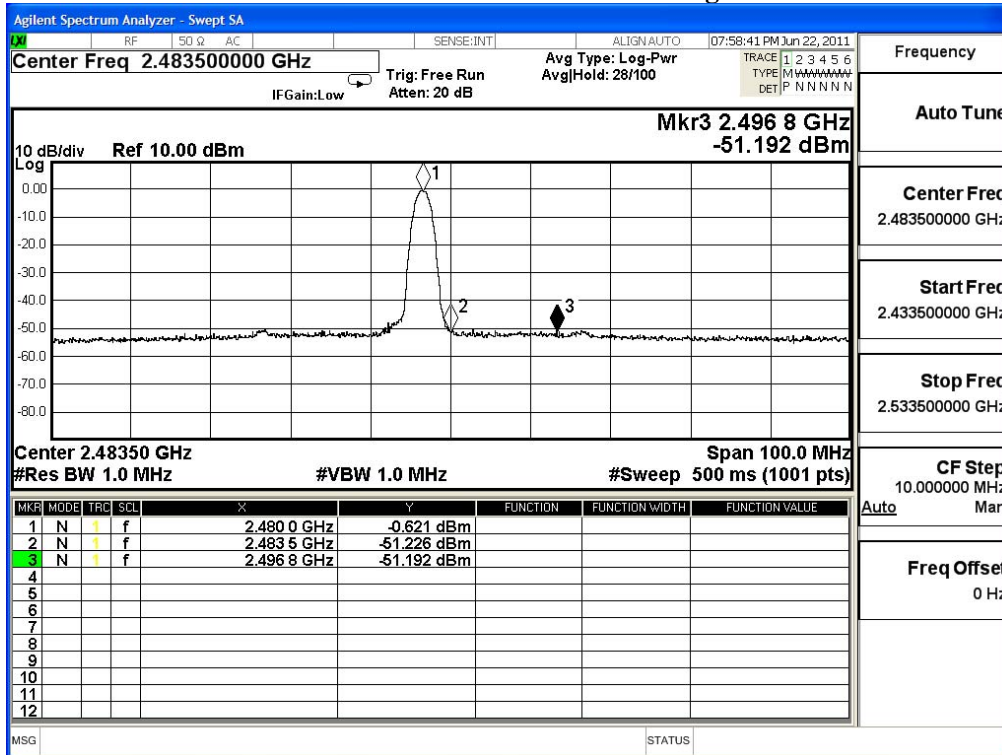

Average Detector of conducted Band Edge Delta

