



FCC RF Test Report

APPLICANT : ASUSTeK COMPUTER INC.
EQUIPMENT : ASUS Phone(Mobile Phone)
BRAND NAME : ASUS
MODEL NAME : ASUS_X017DA
FCC ID : MSQX017DA
STANDARD : FCC Part 15 Subpart C §15.225
CLASSIFICATION : (DXX) Low Power Communication Device Transmitter

The product was received on Nov. 04, 2017 and testing was completed on Feb. 26, 2018. We, Sporton Sporton International (Shenzhen) Inc., would like to declare that the tested sample has been evaluated in accordance with the test procedures and has been in compliance with the applicable technical standards.

The test results in this report apply exclusively to the tested model / sample. Without written approval of Sporton International (Shenzhen) Inc., the test report shall not be reproduced except in full.



Approved by: Eric Shih / Manager

Sporton International (Shenzhen) Inc.

**1/F, 2/F, Bldg 5, Shiling Industrial Zone, Xinwei Village, Xili, Nanshan Shenzhen City
Guangdong Province 518055 China**



TABLE OF CONTENTS

TABLE OF CONTENTS2

REVISION HISTORY.....3

SUMMARY OF THE TEST RESULT4

1. GENERAL INFORMATION.....5

 1.1 Applicant..... 5

 1.2 Manufacturer 5

 1.3 Product Feature of Equipment Under Test 5

 1.4 Product Specification of Equipment Under Test 6

 1.5 Modification of EUT 6

 1.6 Testing Location 7

 1.7 Applicable Standards..... 7

2. TEST CONFIGURATION OF EQUIPMENT UNDER TEST8

 2.1 Descriptions of Test Mode 8

 2.2 Connection Diagram of Test System 8

 2.3 Table for Supporting Units 9

 2.4 EUT Operation Test Setup 9

3. TEST RESULTS.....10

 3.1 AC Power Line Conducted Emissions Measurement 10

 3.2 20dB and 99% OBW Spectrum Bandwidth Measurement..... 12

 3.3 Frequency Stability Measurement 13

 3.4 Field Strength of Fundamental Emissions and Mask Measurement..... 14

 3.5 Radiated Emissions Measurement 16

 3.6 Antenna Requirements..... 19

4. LIST OF MEASURING EQUIPMENT20

APPENDIX A. TEST RESULTS OF CONDUCTED EMISSION TEST

APPENDIX B. TEST RESULTS OF CONDUCTED TEST ITEMS

 B1. Test Result of 20dB Spectrum Bandwidth

 B2. Test Result of Frequency Stability

APPENDIX C. TEST RESULTS OF RADIATED TEST ITEMS

 C1. Test Result of Field Strength of Fundamental Emissions

 C2. Results of Radiated Emissions (9 kHz~30MHz)

 C3. Results of Radiated Emissions (30MHz~1GHz)

APPENDIX D. SETUP PHOTOGRAPHS



REVISION HISTORY

REPORT NO.	VERSION	DESCRIPTION	ISSUED DATE
FR7N0402D	Rev. 01	Initial issue of report	Mar. 22, 2018



SUMMARY OF THE TEST RESULT

Applied Standard: 47 CFR FCC Part 15 Subpart C				
Part	FCC Rule	Description of Test	Result	Remark
3.1	15.207	AC Power Line Conducted Emissions	Complies	Under limit 4.76 dB at 0.48MHz
3.2	15.215(c)	20dB Spectrum Bandwidth	Complies	-
	-	99% OBW Spectrum Bandwidth	Complies	-
3.3	15.225(e)	Frequency Stability	Complies	-
3.4	15.225(a)(b)(c)	Field Strength of Fundamental Emissions	Complies	Max Level 52.09 dBuV/m at 13.56 MHz
3.5	15.225(d) 15.209	Radiated Emissions	Complies	Under limit 4.32 dB at 40.67 MHz for Quasi-Peak
3.6	15.203	Antenna Requirements	Complies	-

Test Items	Uncertainty	Remark
AC Power Line Conducted Emissions	±2.6dB	Confidence levels of 95%
Radiated Emissions (30MHz~1000MHz)	±5.0dB	Confidence levels of 95%



1. GENERAL INFORMATION

1.1 Applicant

ASUSTeK COMPUTER INC.

4F, No. 150, LI-TE RD., PEITOU, TAIPEI, TAIWAN

1.2 Manufacturer

Wingtech Mobile Communications Co, Ltd.

Floor 1st-3rd, Yinfeng Building, No.5097 Luosha Road, Luohu District, Shenzhen

1.3 Product Feature of Equipment Under Test

Product Feature	
Equipment	ASUS Phone(Mobile Phone)
Brand Name	ASUS
Model Name	ASUS_X017DA
FCC ID	MSQX017DA
EUT supports Radios application	GSM/GPRS/EGPRS/WCDMA/HSPA/DC-HSDPA/ HSPA+(16QAM uplink is not supported)/LTE/NFC WLAN 2.4GHz 802.11b/g/n HT20/HT40 WLAN 5GHz 802.11a/n HT20/HT40 WLAN 5GHz 802.11ac VHT20/VHT40/VHT80 Bluetooth v3.0+EDR/Bluetooth v4.0 LE Bluetooth v4.1 LE/Bluetooth v4.2 LE
IMEI Code	Conducted: 353746090026767/353746090026775 Conduction: 353746090027161/353746090027179 Radiation: 353746090026387/353746090026395
HW Version	89199_1_XX
SW Version	NMF26X.WW_Phone-14.0400.1702.001-20171109
EUT Stage	Production Unit

Remark: The above EUT's information was declared by manufacturer. Please refer to the specifications or user's manual for more detailed description.



1.4 Product Specification of Equipment Under Test

Standards-related Product Specification	
Tx/Rx Frequency Range	13.553 ~ 13.567MHz
Channel Number	1
20dBW	2.58 KHz
99%OBW	2.18 KHz
Antenna Type	FPC+ferrite
Type of Modulation	ASK

Remark: The above EUT's information was declared by manufacturer. Please refer to the specifications or user's manual for more detailed description.

1.5 Modification of EUT

No modifications are made to the EUT during all test items.



1.6 Testing Location

Sporton International (Shenzhen) Inc. is accredited to ISO 17025 by National Voluntary Laboratory Accreditation Program (NVLAP code: 600156-0) and the FCC designation No are CN5018 and CN5019.

Test Site	Sporton International (Shenzhen) Inc.		
Test Site Location	1/F, 2/F, Bldg 5, Shiling Industrial Zone, Xinwei Village, Xili, Nanshan Shenzhen City Guangdong Province 518055 China TEL: +86-755-8637-9589 FAX: +86-755-8637-9595		
Test Site No.	Sporton Site No.		FCC Test Firm Registration No.
	TH01-SZ	CO01-SZ	251365
Test Engineer	Rain Wang	Peng Wang	
Temperature	24~26°C	22~25°C	
Relative Humidity	50~53%	50~55%	

Test Site	Sporton International (Shenzhen) Inc.		
Test Site Location	No. 3 Bldg the third floor of south, Shahe River west, Fengzeyuan Warehouse, Nanshan District Shenzhen City Guangdong Province 518055 China TEL: +86-755-3320-2398		
Test Site No.	Sporton Site No.		FCC Test Firm Registration No.
	03CH03-SZ		577730
Test Engineer	Liangliang Lu		
Temperature	23~25°C		
Relative Humidity	48~52%		

Note: The test site complies with ANSI C63.4 2014 requirement.

1.7 Applicable Standards

According to the specifications of the manufacturer, the EUT must comply with the requirements of the following standards:

- ♦ FCC Part 15 Subpart C §15.225
- ♦ ANSI C63.10-2013

2. TEST CONFIGURATION OF EQUIPMENT UNDER TEST

2.1 Descriptions of Test Mode

Investigation has been done on all the possible configurations for searching the worst cases.

The following table is a list of the test modes shown in this test report.

Test Items	
AC Power Line Conducted Emissions	Field Strength of Fundamental Emissions
20dB Spectrum Bandwidth	Frequency Stability
Radiated Emissions 9kHz~30MHz	Radiated Emissions 30MHz~1GHz

The EUT pre-scanned in two NFC type, A, B. The worst type (type B) was recorded in this report.

Pre-scanned tests, X, Y, Z in three orthogonal panels to determine the final configuration (Y plane as worst plane) from all possible combinations.

2.2 Connection Diagram of Test System

<AC Conducted Emissions>

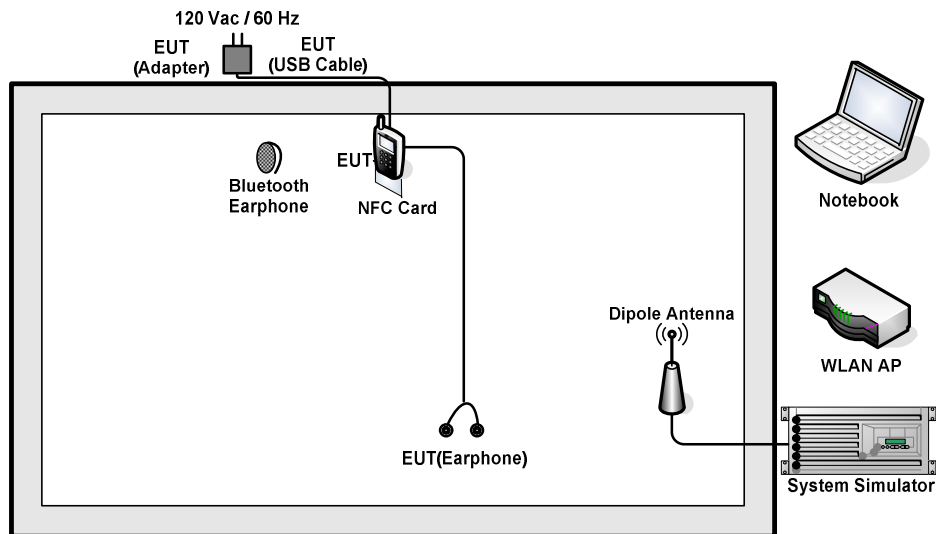

< For Fundamental Emissions and Mask and Radiated Emissions Measurement >

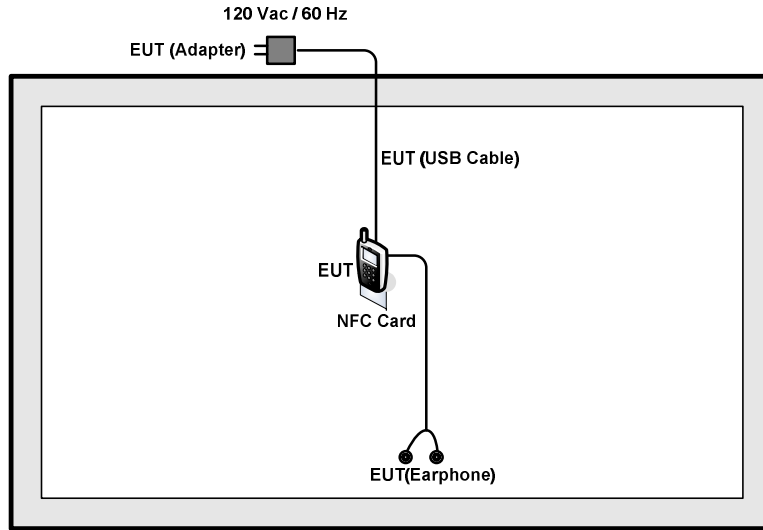

2.3 Table for Supporting Units

Support Unit	Manufacturer	Model	FCC ID
System Simulator	R&S	CMU 200	N/A
WLAN AP	Dlink	DIR-820L	KA2IR820LA1
Notebook	Lenovo	E540	FCC DoC
Bluetooth Earphone	Samsung	EO-MG900	PYAHS-107W
SD Card	N/A	MicroSD HC	FCC DoC
NFC Card	PAX	A Card	N/A

2.4 EUT Operation Test Setup

The EUT was programmed to be in continuously transmitting mode.

The ancillary equipment, NFC card, is used to make the EUT (NFC) continuously transmit at 13.56MHz and is placed around 3 cm gap to the EUT.



3. TEST RESULTS

3.1 AC Power Line Conducted Emissions Measurement

3.1.1 Limit of AC Conducted Emission

For equipment that is designed to be connected to the public utility (AC) power line, the radio frequency voltage that is conducted back onto the AC power line on any frequency or frequencies within the band 150 kHz to 30 MHz shall not exceed the limits in the following table.

Frequency of Emission (MHz)	Conducted Limit (dBµV)	
	Quasi-Peak	Average
0.15-0.5	66 to 56*	56 to 46*
0.5-5	56	46
5-30	60	50

*Decreases with the logarithm of the frequency.

For terminal test result, the testing follows FCC KDB 174176.

3.1.2 Measuring Instruments

See list of measuring instruments of this test report.

3.1.3 Test Procedures

1. The EUT was placed 0.4 meter from the conducting wall of the shielding room, and it was kept at least 80 centimeters from any other grounded conducting surface.
2. Connect EUT to the power mains through a line impedance stabilization network (LISN).
3. All the support units are connecting to the other LISN.
4. The LISN provides 50 ohm coupling impedance for the measuring instrument.
5. The FCC states that a 50 ohm, 50 microhenry LISN should be used.
6. Both sides of AC line were checked for maximum conducted interference.
7. The frequency range from 150 kHz to 30 MHz was searched.
8. Set the test-receiver system to Peak Detect Function and specified bandwidth (IF Bandwidth = 9kHz) with Maximum Hold Mode. Then measurement is also conducted by Average Detector and Quasi-Peak Detector Function respectively.

3.1.4 Test setup

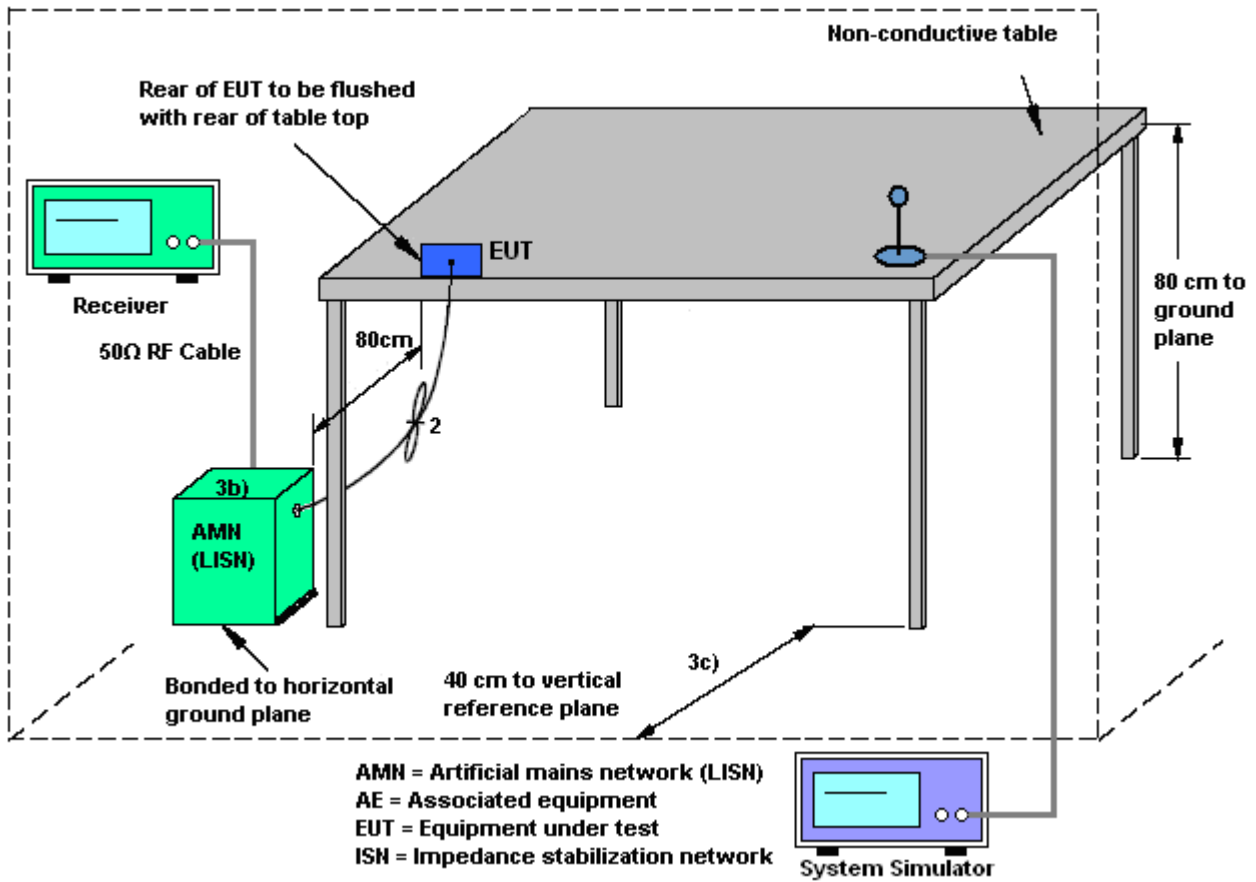

3.1.5 Test Result of AC Conducted Emission

Please refer to Appendix A.

3.2 20dB and 99% OBW Spectrum Bandwidth Measurement

3.2.1 Limit

Intentional radiators must be designed to ensure that the 20dB and 99% emission bandwidth in the specific band 13.553~13.567MHz.

3.2.2 Measuring Instruments

See list of measuring instruments of this test report.

3.2.3 Test Procedures

1. The spectrum analyzer connected via a receive antenna placed near the EUT in peak Max hold mode.
2. The resolution bandwidth of 1 kHz and the video bandwidth of 3 kHz were used.
3. Measured the spectrum width with power higher than 20dB below carrier.
4. Measured the 99% OBW.

3.2.4 Test Setup

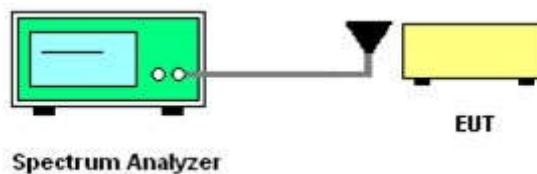

3.2.5 Test Result of Conducted Test Items

Please refer to Appendix B.

3.3 Frequency Stability Measurement

3.3.1 Limit

The frequency tolerance of the carrier signal shall be maintained within +/- 0.01% (100ppm) of the operating frequency over a temperature variation of -20 degrees to +50 degrees C at normal supply voltage, and for a variation in the primary supply voltage from 85% to 115% of the rated supply voltage at a temperature of 20 degrees C. For battery operated equipment, the equipment tests shall be performed using a new battery.

3.3.2 Measuring Instruments

See list of measuring instruments of this test report.

3.3.3 Test Procedures

1. The spectrum analyzer connected via a receive antenna placed near the EUT.
2. EUT have transmitted signal and fixed channelize.
3. Set the spectrum analyzer span to view the entire emissions bandwidth.
4. Set RBW = 1 kHz, VBW = 3 kHz with peak detector and maxhold settings.
5. The f_c is declaring of channel frequency. Then the frequency error formula is $(f_c - f) / f_c \times 10^6$ ppm and the limit is less than ± 100 ppm.
6. Extreme temperature rule is -20°C~50°C.

3.3.4 Test Setup

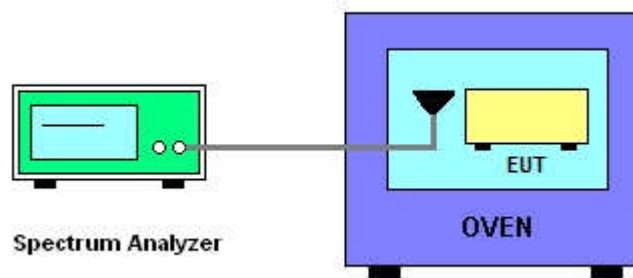

3.3.5 Test Result of Conducted Test Items

Please refer to Appendix B.



3.4 Field Strength of Fundamental Emissions and Mask Measurement

3.4.1 Limit

Rules and specifications	FCC CFR 47 Part 15 section 15.225			
Description	Compliance with the spectrum mask is tested with RBW set to 9kHz.			
Freq. of Emission (MHz)	Field Strength (μV/m) at 30m	Field Strength (dBμV/m) at 30m	Field Strength (dBμV/m) at 10m	Field Strength (dBμV/m) at 3m
1.705~13.110	30	29.5	48.58	69.5
13.110~13.410	106	40.5	59.58	80.5
13.410~13.553	334	50.5	69.58	90.5
13.553~13.567	15848	84.0	103.08	124.0
13.567~13.710	334	50.5	69.58	90.5
13.710~14.010	106	40.5	59.58	80.5
14.010~30.000	30	29.5	48.58	69.5

3.4.2 Measuring Instruments

See list of measuring instruments of this test report.

3.4.3 Test Procedures

1. Configure the EUT according to ANSI C63.10. The EUT was placed on the top of the turntable 0.8 meter above ground. The phase center of the loop receiving antenna mounted antenna tower was placed 3 meters far away from the turntable.
2. Power on the EUT and all the supporting units. The turntable was rotated by 360 degrees to determine the position of the highest radiation.
3. The height of the receiving antenna was fixed at one meter above ground to find the maximum emissions field strength.
4. For Fundamental emissions, use the receiver to measure QP reading.

5. When the radiated emissions limits are expressed in terms of the average value of the emissions, and pulsed operation is employed, the measurement field strength shall be determined by averaging over one complete pulse train, including blanking intervals, as long as the pulse train does not exceed 0.1 seconds. As an alternative (provided the transmitter operates for longer than 0.1 seconds) or in cases where the pulse train exceeds 0.1 seconds, the measured field strength shall be determined from the average absolute voltage during a 0.1 second interval during which the field strength is at its maximum value.
6. Compliance with the spectrum mask is tested with RBW set to 9kHz.
Note: Emission level (dB μ V/m) = 20 log Emission level (μ V/m).

3.4.4 Test Setup

For radiated emissions below 30MHz

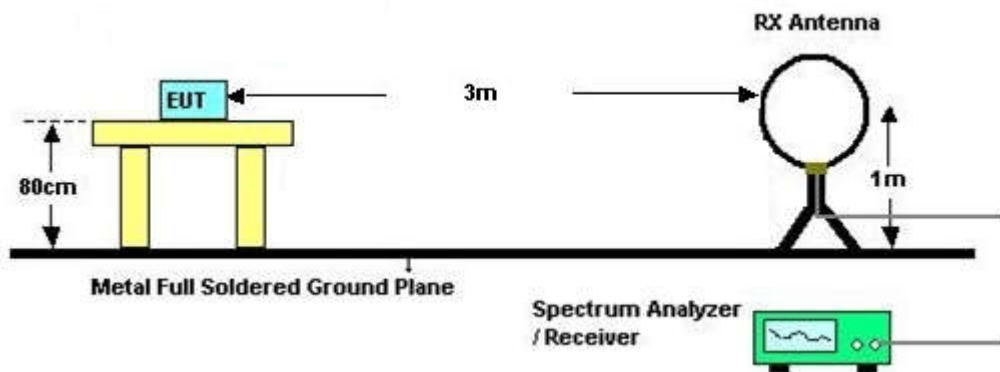

3.4.5 Test Result of Field Strength of Fundamental Emissions and Mask

Please refer to Appendix C.

3.5 Radiated Emissions Measurement

3.5.1 Limit

The field strength of any emissions which appear outside of 13.110 ~14.010MHz band shall not exceed the general radiated emissions limits.

Frequencies (MHz)	Field Strength (μV/m)	Measurement Distance (meters)
0.009~0.490	2400/F(kHz)	300
0.490~1.705	24000/F(kHz)	30
1.705~30.0	30	30
30~88	100	3
88~216	150	3
216~960	200	3
Above 960	500	3

3.5.2 Measuring Instruments

See list of measuring instruments of this test report.

3.5.3 Measuring Instrument Setting

The following table is the setting of receiver.

Receiver Parameter	Setting
Attenuation	Auto
Frequency Range: 9kHz~150kHz	RBW 200Hz for QP
Frequency Range: 150kHz~30MHz	RBW 9kHz for QP
Frequency Range: 30MHz~1000MHz	RBW 120kHz for Peak

Note: The emission limits shown in the above table are based on measurements employing a CISPR quasi-peak detector except for the frequency bands 9-90 kHz, 110-490 kHz. Radiated emission limits in these two bands are based on measurements employing an average detector.



3.5.4 Test Procedures

1. Configure the EUT according to ANSI C63.10. The EUT was placed on the top of the turntable 0.8 meter above ground. The phase center of the receiving antenna mounted on the top of a height-variable antenna tower was placed 3 meters far away from the turntable.
2. Power on the EUT and all the supporting units. The turntable was rotated by 360 degrees to determine the position of the highest radiation.
3. The height of the broadband receiving antenna was varied between one meter and four meters above ground to find the maximum emissions field strength of both horizontal and vertical polarization.
4. For each suspected emissions, the antenna tower was scan (from 1 M to 4 M) and then the turntable was rotated (from 0 degree to 360 degrees) to find the maximum reading.
5. Set the test-receiver system to Peak or CISPR quasi-peak Detect Function with specified bandwidth under Maximum Hold Mode.
6. When the radiated emissions limits are expressed in terms of the average value of the emissions, and pulsed operation is employed, the measurement field strength shall be determined by averaging over one complete pulse train, including blanking intervals, as long as the pulse train does not exceed 0.1 seconds. As an alternative (provided the transmitter operates for longer than 0.1 seconds) or in cases where the pulse train exceeds 0.1 seconds, the measured field strength shall be determined from the average absolute voltage during a 0.1 second interval during which the field strength is at its maximum value.
7. In case the emission is lower than 30MHz, loop antenna has to be used for measurement and the recorded data should be QP measured by receiver. Antenna Requirements

3.5.5 Test Setup

For radiated emissions above 30MHz

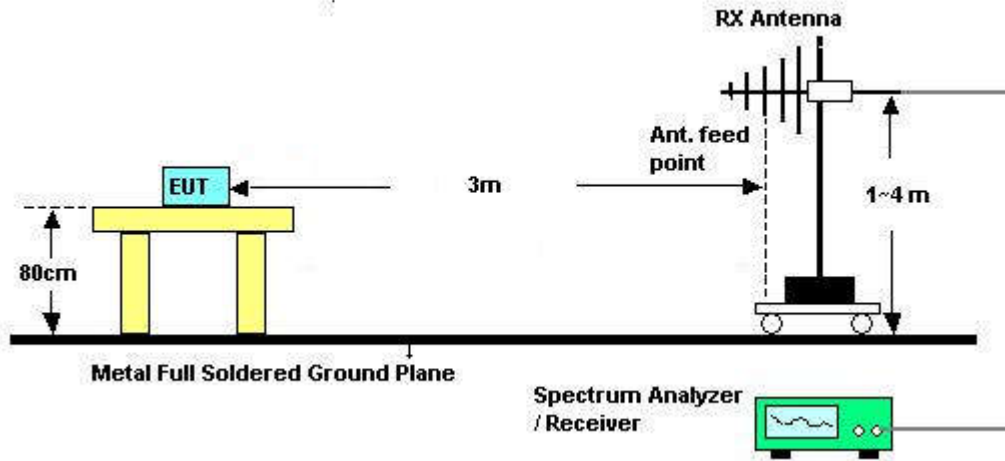

3.5.6 Test Result of Radiated Emissions Measurement

Please refer to Appendix C.



3.6 Antenna Requirements

3.6.1 Standard Applicable

Except for special regulations, the Low-power Radio-frequency Devices must not be equipped with any jacket for installing an antenna with extension cable. An intentional radiator shall be designed to ensure that no antenna other than that furnished by the responsible party shall be used with the device. The use of a permanently attached antenna or of an antenna that uses a unique coupling to the intentional radiator shall be considered sufficient to comply with the provisions of this Section. The manufacturer may design the unit so that the user can replace a broken antenna, but the use of a standard antenna jack or electrical connector is prohibited.

The use of a permanently attached antenna or of an antenna that uses a unique coupling to the intentional radiator shall be considered sufficient to comply with the FCC rule.

3.6.2 Antenna Anti-Replacement Construction

An embedded-in antenna design is used.



4. LIST OF MEASURING EQUIPMENT

Instrument	Manufacturer	Model No.	Serial No.	Characteristics	Calibration Date	Test Date	Due Date	Remark
Spectrum Analyzer	R&S	FSV40	101078	9kHz~40GHz	Apr. 20, 2017	Feb. 26, 2018	Apr. 19, 2018	Conducted (TH01-SZ)
Thermal Chamber	Ten Billion Hongzhangroup	LP-150U	H2014081803	-40~+150°C	Jul. 20, 2017	Feb. 26, 2018	Jul. 19, 2018	Conducted (TH01-SZ)
AC Power Source	Chroma	61602	ABP000000811	AC 0V~300V, 45Hz~1000Hz	Oct. 12, 2017	Feb. 26, 2018	Oct. 11, 2018	Conducted (TH01-SZ)
EMI Test Receiver&SA	KEYSIGHT	N9038A	MY54450083	20Hz~8.4GHz	Apr.20, 2017	Feb. 01, 2018	Apr.19, 2018	Radiation (03CH03-SZ)
Loop Antenna	R&S	HFH2-Z2	100354	9kHz~30MHz	May. 14, 2017	Feb. 01, 2018	May.13, 2018	Radiation (03CH03-SZ)
Bilog Antenna	TeseQ	CBL6112D	35408	30MHz-2GHz	May. 14, 2017	Feb. 01, 2018	May. 13, 2018	Radiation (03CH03-SZ)
Amplifier	Burgeon	BPA-530	102210	0.01Hz~3000MHz	OCT.19,2017	Feb. 01, 2018	OCT.18,2018	Radiation (03CH03-SZ)
AC Power Source	Chroma	61601	616010001985	N/A	NCR	Feb. 01, 2018	NCR	Radiation (03CH03-SZ)
Turn Table	EM	EM1000	N/A	0~360 degree	NCR	Feb. 01, 2018	NCR	Radiation (03CH03-SZ)
Antenna Mast	EM	EM1000	N/A	1 m~4 m	NCR	Feb. 01, 2018	NCR	Radiation (03CH03-SZ)
EMI Receiver	R&S	ESR7	101630	9kHz~7GHz;	Dec.26, 2017	Jan. 25, 2018~Feb. 06, 2018	Dec.25, 2018	Conduction (CO01-SZ)
AC LISN	EMCO	3816/2SH	00103912	9kHz~30MHz	Dec.26, 2017	Jan. 25, 2018~Feb. 06, 2018	Dec.25, 2018	Conduction (CO01-SZ)
AC LISN (for auxiliary equipment)	MessTec	3816/2SH	00103892	9kHz~30MHz	Nov.01, 2017	Jan. 25, 2018~Feb. 06, 2018	Oct.31, 2018	Conduction (CO01-SZ)
AC Power Source	Chroma	61602	616020000891	100Vac~250Vac	Jul. 19, 2017	Jan. 25, 2018~Feb. 06, 2018	Jul. 18, 2018	Conduction (CO01-SZ)

NCR: No Calibration Required



Appendix A. Test Results of Conducted Emission Test

Test Mode :	NFC Tx	Test Voltage :	120Vac / 60Hz
Function Type :	GSM850 Idle + Bluetooth Link + WLAN Link(2.4G) + USB Cable 1(Charging from Adapter 1) + Earphone + NFC Tx + SMI 1		

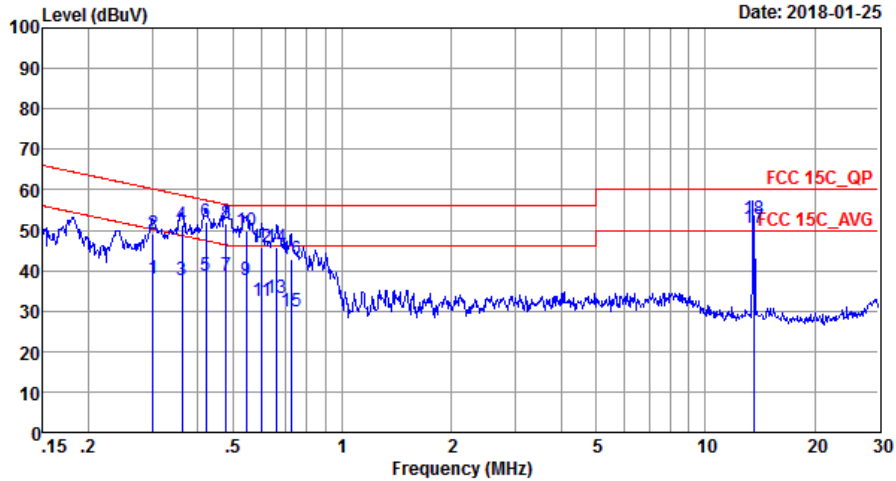

Site : C001-SZ
 Condition: FCC 15C QP LISN 20170907_L LINE

Mode : Mode 1
 IMEI : 353746090027161/353746090027179

	Freq	Level	Over Limit	Limit Line	Read Level	LISN Factor	Cable Loss	Remark
	MHz	dBuV	dB	dBuV	dBuV	dB	dB	
1	0.30	38.11	-12.08	50.19	28.00	0.03	10.08	Average
2	0.30	48.91	-11.28	60.19	38.80	0.03	10.08	QP
3	0.36	37.61	-11.08	48.69	27.50	0.03	10.08	Average
4	0.36	51.11	-7.58	58.69	41.00	0.03	10.08	QP
5	0.42	38.71	-8.71	47.42	28.60	0.03	10.08	Average
6	0.42	52.01	-5.41	57.42	41.90	0.03	10.08	QP
7	0.48	38.60	-7.76	46.36	28.50	0.02	10.08	Average
8	0.48	51.60	-4.76	56.36	41.50	0.02	10.08	QP
9	0.54	37.80	-8.20	46.00	27.70	0.02	10.08	Average
10	0.54	49.90	-6.10	56.00	39.80	0.02	10.08	QP
11	0.60	32.60	-13.40	46.00	22.50	0.02	10.08	Average
12	0.60	45.90	-10.10	56.00	35.80	0.02	10.08	QP
13	0.66	33.30	-12.70	46.00	23.20	0.02	10.08	Average
14	0.66	45.90	-10.10	56.00	35.80	0.02	10.08	QP
15	0.72	30.01	-15.99	46.00	19.91	0.02	10.08	Average
16	0.72	42.71	-13.29	56.00	32.61	0.02	10.08	QP
17 *	13.56	50.56	0.56	50.00	39.70	0.47	10.39	Average
18	13.56	52.66	-7.34	60.00	41.80	0.47	10.39	QP

(1) with antenna

Remark: 13.560MHz is the NFC RF fundamental signal.



Test Mode :	NFC Tx	Test Voltage :	120Vac / 60Hz
Function Type :	GSM850 Idle + Bluetooth Link + WLAN Link(2.4G) + USB Cable 1(Charging from Adapter 1) + Earphone + NFC Tx + SMI 1		

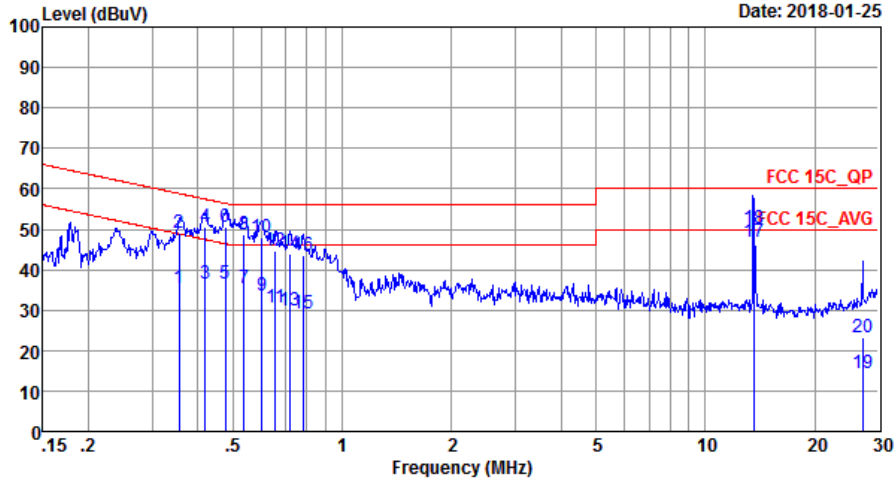

Site : CO01-SZ
 Condition: FCC 15C_QP LISN_20170907_N NEUTRAL

Mode : Mode 1
 IMEI : 353746090027161/353746090027179

	Freq	Level	Over Limit	Limit Line	Read Level	LISN Factor	Cable Loss	Remark
	MHz	dBuV	dB	dBuV	dBuV	dB	dB	
1	0.36	35.40	-13.43	48.83	25.30	0.02	10.08	Average
2	0.36	49.20	-9.63	58.83	39.10	0.02	10.08	QP
3	0.42	36.60	-10.86	47.46	26.50	0.02	10.08	Average
4	0.42	50.50	-6.96	57.46	40.40	0.02	10.08	QP
5	0.48	36.60	-9.81	46.41	26.50	0.02	10.08	Average
6	0.48	50.60	-5.81	56.41	40.50	0.02	10.08	QP
7	0.54	35.60	-10.40	46.00	25.50	0.02	10.08	Average
8	0.54	48.70	-7.30	56.00	38.60	0.02	10.08	QP
9	0.60	33.40	-12.60	46.00	23.30	0.02	10.08	Average
10	0.60	47.80	-8.20	56.00	37.70	0.02	10.08	QP
11	0.65	30.70	-15.30	46.00	20.60	0.02	10.08	Average
12	0.65	44.70	-11.30	56.00	34.60	0.02	10.08	QP
13	0.72	30.00	-16.00	46.00	19.90	0.02	10.08	Average
14	0.72	43.80	-12.20	56.00	33.70	0.02	10.08	QP
15	0.78	29.31	-16.69	46.00	19.20	0.03	10.08	Average
16	0.78	43.41	-12.59	56.00	33.30	0.03	10.08	QP
17 *	13.56	46.98	-3.02	50.00	36.30	0.29	10.39	Average
18	13.56	50.28	-9.72	60.00	39.60	0.29	10.39	QP
19	27.13	14.49	-35.51	50.00	2.90	1.15	10.44	Average
20	27.13	23.29	-36.71	60.00	11.70	1.15	10.44	QP

(1) with antenna

Remark: 13.560MHz is the NFC RF fundamental signal.



Test Mode :	NFC Tx	Test Voltage :	120Vac / 60Hz
Function Type :	GSM850 Idle + Bluetooth Link + WLAN Link(2.4G) + USB Cable 1(Charging from Adapter 1) + Earphone + NFC Tx + SMI 1		

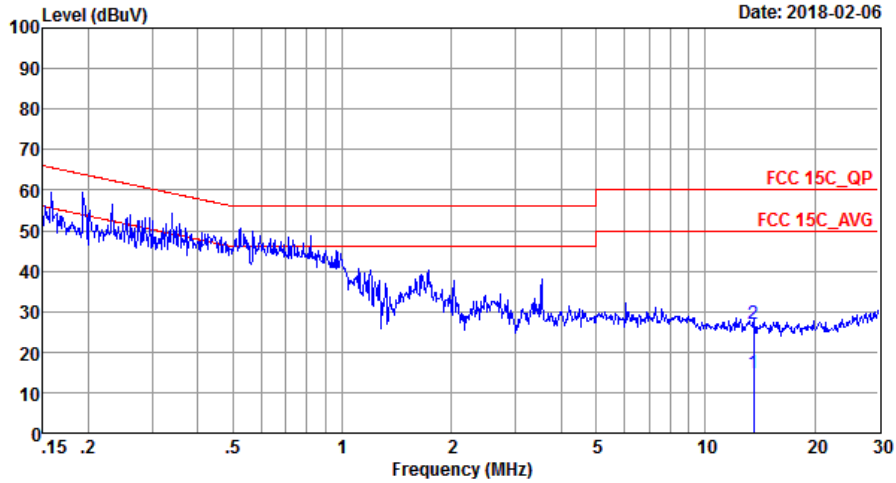

Site : C001-SZ
Condition: FCC 15C_QP LISN_20170907_L LINE

IMEI : 353746090027161/353746090027179

	Freq	Level	Over Limit	Limit Line	Read Level	LISN Factor	Cable Loss	Remark
	MHz	dBuV	dB	dBuV	dBuV	dB	dB	
1	13.56	14.76	-35.24	50.00	3.90	0.47	10.39	Average
2 *	13.56	26.76	-33.24	60.00	15.90	0.47	10.39	QP

(2) With dummy load

Remark: Only the fundamental NFC signal needs to be retested per C63.4.



Test Mode :	NFC Tx	Test Voltage :	120Vac / 60Hz
Function Type :	GSM850 Idle + Bluetooth Link + WLAN Link(2.4G) + USB Cable 1(Charging from Adapter 1) + Earphone + NFC Tx + SMI 1		

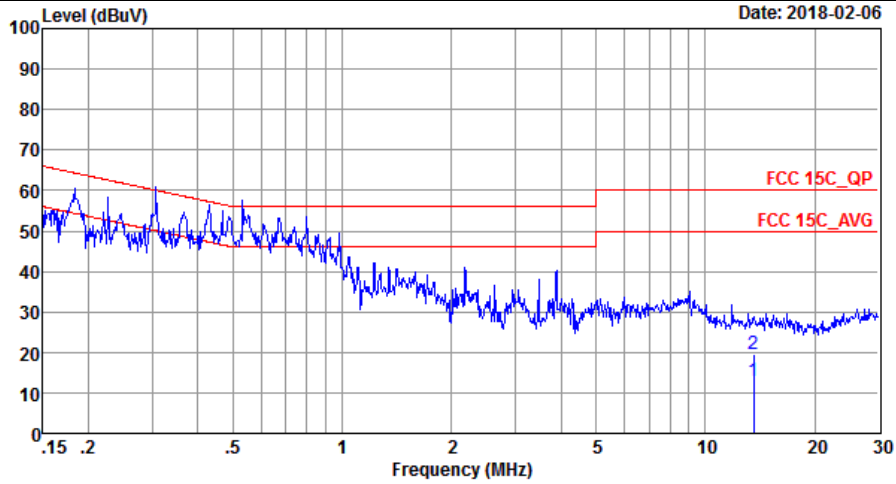

Site : C001-SZ
 Condition: FCC 15C_QP LISN_20170907_N NEUTRAL

IMEI : 353746090027161/353746090027179

	Freq	Level	Over Limit	Limit Line	Read Level	LISN Factor	Cable Loss	Remark
	MHz	dBuV	dB	dBuV	dBuV	dB	dB	
1 *	13.56	12.88	-37.12	50.00	2.20	0.29	10.39	Average
2	13.56	19.68	-40.32	60.00	9.00	0.29	10.39	QP

(2) With dummy load

Remark: Only the fundamental NFC signal needs to be retested per C63.4.



Appendix B. Test Results of Conducted Test Items

B1. Test Result of 20dB Spectrum Bandwidth

Test mode	NFC Tx	Test Frequency (MHz)	13.56
20dB Bandwidth (kHz)	2.58	99% OccupiedBW(kHz)	2.18
Frequency range (MHz)	$f_L > 13.553$	13.558452	Test Result
	$f_H < 13.567$	13.561029	Complies



B2. Test Result of Frequency Stability

Voltage vs. Frequency Stability		Temperature vs. Frequency Stability	
Voltage (Vac)	Measurement Frequency (MHz)	Temperature (°C)	Measurement Frequency (MHz)
102	13.559706	-20	13.559776
120	13.559726	-10	13.559776
138	13.559706	0	13.559810
		10	13.559766
		20	13.559711
		30	13.559676
		40	13.560176
		50	13.559676
Max.Deviation (MHz)	-0.000295	Max.Deviation (MHz)	-0.000324
Max.Deviation (ppm)	-21.7183	Max.Deviation (ppm)	-23.9307
Limit	FS < ±100 ppm	Limit	FS < ±100 ppm
Test Result	PASS	Test Result	PASS



Appendix C. Test Results of Radiated Test Items

C1. Test Result of Field Strength of Fundamental Emissions

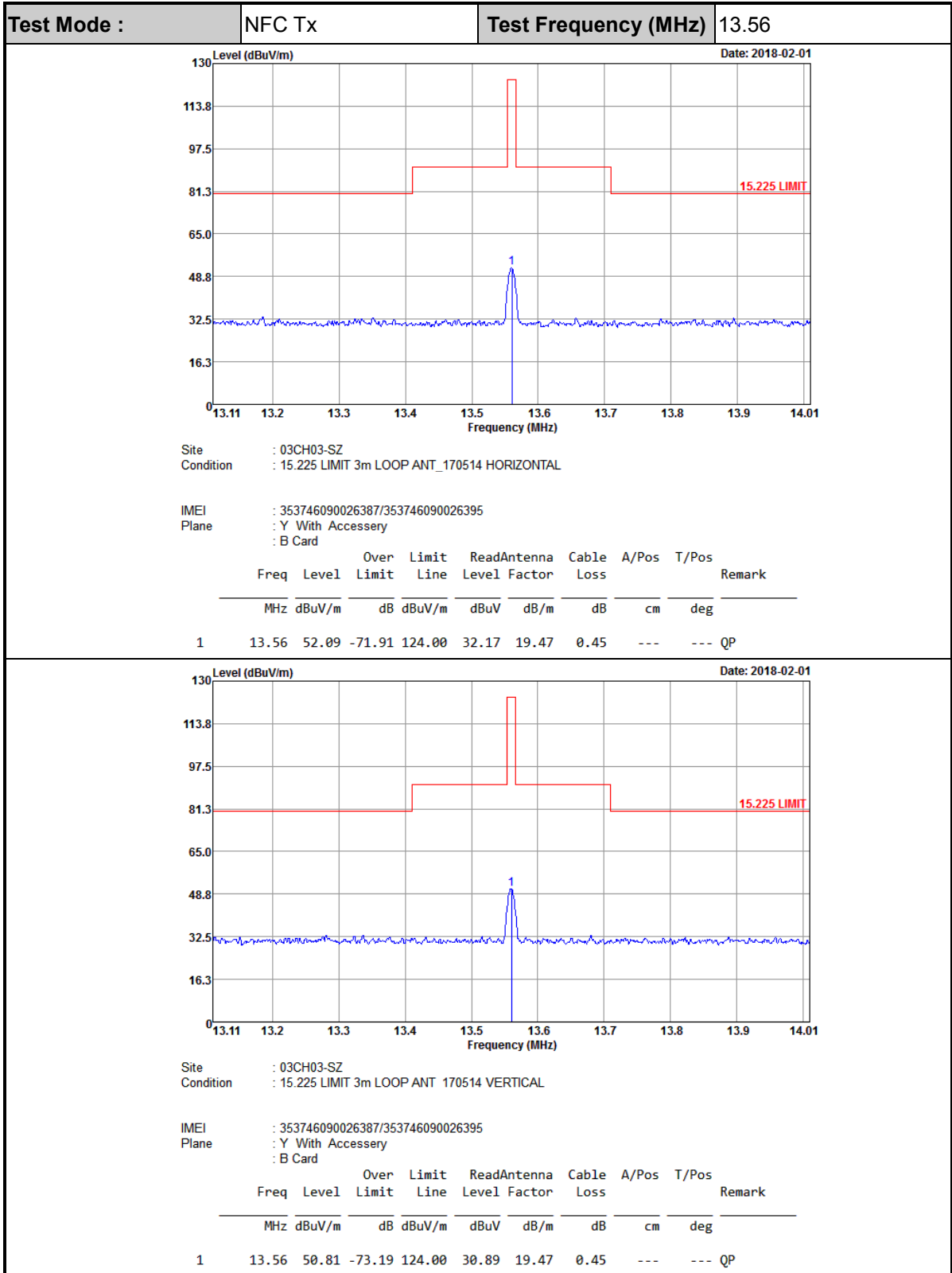



C2. Results of Radiated Spurious Emissions (9 kHz~30MHz)

Test Mode :		NFC Tx			Polarization :		Horizontal		
Frequency (MHz)	Level (dBμV/m)	Over Limit (dB)	Limit Line (dBμV/m)	Read Level (dBμV)	Antenna Factor (dB)	Cable Loss (dB)	Ant Pos (cm)	Table Pos (deg)	Remark
0.01124	51.21	-75.38	126.59	30.16	21	0.05	-	-	Average
0.06537	39.78	-71.52	111.3	19.22	20.5	0.06	-	-	Average
0.0978	33.01	-74.79	107.8	12.24	20.7	0.07	-	-	QP
0.12981	34.35	-70.99	105.34	13.67	20.6	0.08	-	-	Average
0.2906	45.6	-52.74	98.34	25.17	20.34	0.09	-	-	Average
2.06	36.81	-33.19	70	16.08	20.55	0.18	-	-	QP
10.312	34.4	-35.6	70	13.67	20.33	0.4	-	-	QP
19.078	34.53	-35.47	70	14.52	19.49	0.52	-	-	QP
29.705	34.79	-35.21	70	14.54	19.58	0.67	-	-	QP

Test Mode :		NFC Tx			Polarization :		Vertical		
Frequency (MHz)	Level (dBμV/m)	Over Limit (dB)	Limit Line (dBμV/m)	Read Level (dBμV)	Antenna Factor (dB)	Cable Loss (dB)	Ant Pos (cm)	Table Pos (deg)	Remark
0.01135	50.52	-75.99	126.51	29.47	21	0.05	-	-	Average
0.0654	43.05	-68.24	111.29	22.49	20.5	0.06	-	-	Average
0.09363	35.16	-73.02	108.18	14.39	20.7	0.07	-	-	QP
0.14268	36.37	-68.15	104.52	15.69	20.6	0.08	-	-	Average
0.1537	46.37	-57.5	103.87	25.97	20.3	0.1	-	-	Average
2.198	36.33	-33.67	70	15.6	20.54	0.19	-	-	QP
8.264	34.34	-35.66	70	13.55	20.44	0.35	-	-	QP
22.615	33.21	-36.79	70	13.43	19.22	0.56	-	-	QP
28.745	34.77	-35.23	70	14.78	19.33	0.66	-	-	QP

Note:

1. The amplitude of spurious emissions which are attenuated by more than 20dB below the permissible value has no need to be reported.
2. Distance extrapolation factor = 40 log (specific distance / test distance) (dB);
3. Limit line = specific limits (dBμV) + distance extrapolation factor.



C3. Results of Radiated Spurious Emissions (30MHz~1GHz)

Test Mode :	NFC Tx	Polarization :	Horizontal
-------------	--------	----------------	------------

Frequency (MHz)	Level (dBμV/m)	Over Limit (dB)	Limit Line (dBμV/m)	Read Level (dBμV)	Antenna Factor (dB)	Cable Loss (dB)	Preamp Factor (dB)	Ant Pos (cm)	Table Pos (deg)	Remark
31.94	24.88	-15.12	40	31.03	25.86	0.59	32.6	-	-	Peak
108.57	28.75	-14.75	43.5	41.16	18.63	1.07	32.11	-	-	Peak
169.68	32.64	-10.86	43.5	46.19	16.94	1.34	31.83	-	-	Peak
190.05	33.44	-10.06	43.5	47.46	16.03	1.41	31.46	155	30	Peak
203.63	29.6	-13.9	43.5	43.69	15.78	1.48	31.35	-	-	Peak
353.01	28.83	-17.17	46	38.01	20.73	1.99	31.9	-	-	Peak

Test Mode :	NFC Tx	Polarization :	Vertical
-------------	--------	----------------	----------

Frequency (MHz)	Level (dBμV/m)	Over Limit (dB)	Limit Line (dBμV/m)	Read Level (dBμV)	Antenna Factor (dB)	Cable Loss (dB)	Preamp Factor (dB)	Ant Pos (cm)	Table Pos (deg)	Remark
40.67	35.68	-4.32	40	45.78	21.94	0.66	32.7	120	40	QP
48.43	32.25	-7.75	40	46.89	17.3	0.71	32.65	-	-	Peak
67.83	24.82	-15.18	40	43.1	13.38	0.84	32.5	-	-	Peak
168.71	28.22	-15.28	43.5	41.73	16.98	1.34	31.83	-	-	Peak
190.05	28.01	-15.49	43.5	42.03	16.03	1.41	31.46	-	-	Peak
960.23	32.95	-21.05	54	31.08	29.61	3.41	31.15	-	-	Peak

Note:

1. The amplitude of spurious emissions which are attenuated by more than 20dB below the permissible value has no need to be reported.
2. Emission level (dBμV/m) = 20 log Emission level (μV/m).
3. Corrected Reading: Antenna Factor + Cable Loss + Read Level - Preamp Factor= Level.