

#01_GSM850_GPRS (2 Tx slots)_Right Cheek_Ch251

Communication System: GSM850; Frequency: 848.8 MHz; Duty Cycle: 1:4.15

Medium: HSL_850_180219 Medium parameters used: $f = 849$ MHz; $\sigma = 0.908$ S/m; $\epsilon_r = 43.018$; $\rho = 1000$ kg/m³

Ambient Temperature : 23.5 °C ; Liquid Temperature : 22.5 °C

DASY5 Configuration:

- Probe: ES3DV3 - SN3169; ConvF(5.99, 5.99, 5.99); Calibrated: 2017/5/11;
- Sensor-Surface: 3mm (Mechanical Surface Detection)
- Electronics: DAE3 Sn495; Calibrated: 2017/5/22
- Phantom: SAM_Right; Type: QD000P40CD; Serial: 1884
- Measurement SW: DASY52, Version 52.8 (8); SEMCAD X Version 14.6.10 (7373)

Area Scan (61x121x1): Interpolated grid: dx=1.500 mm, dy=1.500 mm

Maximum value of SAR (interpolated) = 0.747 W/kg

Zoom Scan (5x5x7)/Cube 0: Measurement grid: dx=8mm, dy=8mm, dz=5mm

Reference Value = 21.65 V/m; Power Drift = 0.00 dB

Peak SAR (extrapolated) = 1.16 W/kg

SAR(1 g) = 0.553 W/kg; SAR(10 g) = 0.289 W/kg

Maximum value of SAR (measured) = 0.752 W/kg

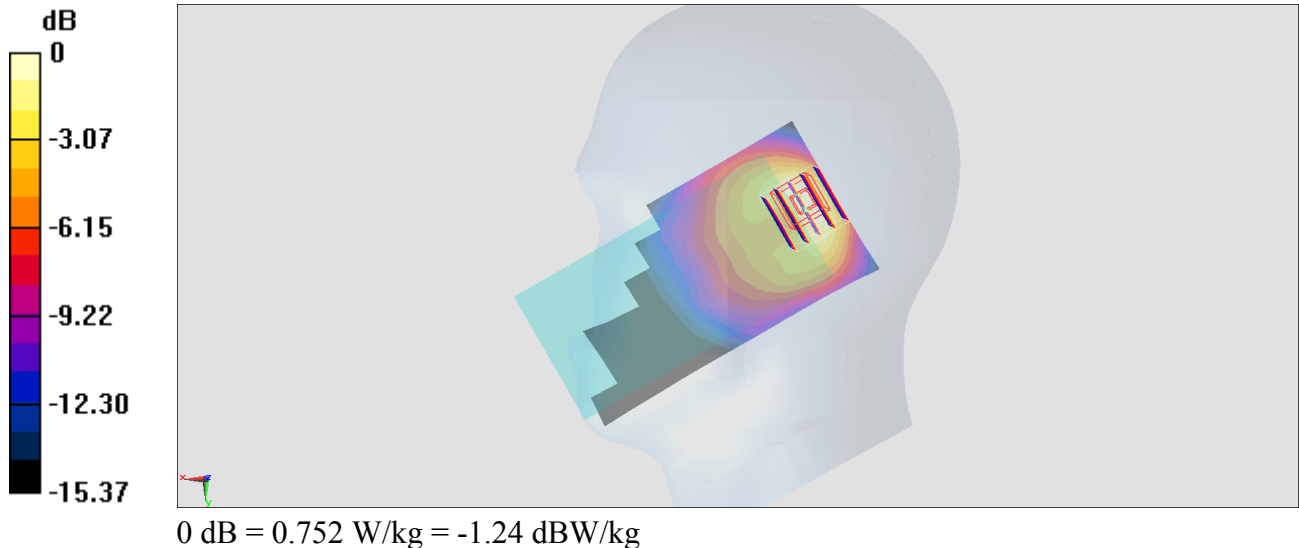

#02_GSM1900_GPRS (2 Tx slots)_Right Tilted_Ch810

Communication System: PCS ; Frequency: 1909.8 MHz;Duty Cycle: 1:4.15

Medium: HSL_1900_180218 Medium parameters used: $f = 1910$ MHz; $\sigma = 1.443$ S/m; $\epsilon_r = 40.978$; $\rho = 1000$ kg/m³

Ambient Temperature : 23.3 °C ; Liquid Temperature : 22.3 °C

DASY5 Configuration:

- Probe: ES3DV3 - SN3169; ConvF(5.03, 5.03, 5.03); Calibrated: 2017/5/11;
- Sensor-Surface: 3mm (Mechanical Surface Detection)
- Electronics: DAE3 Sn495; Calibrated: 2017/5/22
- Phantom: SAM_Right; Type: QD000P40CD; Serial: 1884
- Measurement SW: DASY52, Version 52.8 (8);SEMCAD X Version 14.6.10 (7373)

Area Scan (61x121x1): Interpolated grid: dx=1.500 mm, dy=1.500 mm

Maximum value of SAR (interpolated) = 0.713 W/kg

Zoom Scan (5x5x7)/Cube 0: Measurement grid: dx=8mm, dy=8mm, dz=5mm

Reference Value = 9.847 V/m; Power Drift = 0.14 dB

Peak SAR (extrapolated) = 1.04 W/kg

SAR(1 g) = 0.526 W/kg; SAR(10 g) = 0.248 W/kg

Maximum value of SAR (measured) = 0.640 W/kg

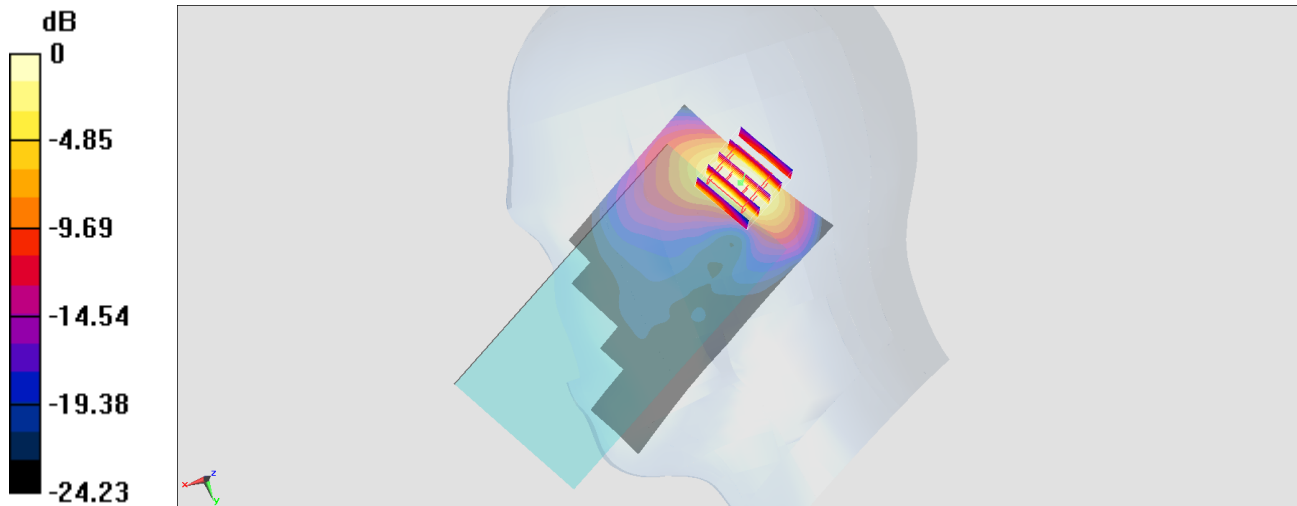

0 dB = 0.640 W/kg = -1.94 dBW/kg

#03_WCDMA II_RMC 12.2Kbps_Right Tilted_Ch9400

Communication System: WCDMA; Frequency: 1880 MHz; Duty Cycle: 1:1

Medium: HSL_1900_180218 Medium parameters used: $f = 1880$ MHz; $\sigma = 1.413$ S/m; $\epsilon_r = 41.099$; $\rho = 1000$ kg/m³

Ambient Temperature : 23.3 °C ; Liquid Temperature : 22.3 °C

DASY5 Configuration:

- Probe: ES3DV3 - SN3169; ConvF(5.03, 5.03, 5.03); Calibrated: 2017/5/11;
- Sensor-Surface: 3mm (Mechanical Surface Detection)
- Electronics: DAE3 Sn495; Calibrated: 2017/5/22
- Phantom: SAM_Right; Type: QD000P40CD; Serial: 1884
- Measurement SW: DASY52, Version 52.8 (8); SEMCAD X Version 14.6.10 (7373)

Area Scan (61x121x1): Interpolated grid: dx=1.500 mm, dy=1.500 mm

Maximum value of SAR (interpolated) = 0.690 W/kg

Zoom Scan (5x5x7)/Cube 0: Measurement grid: dx=8mm, dy=8mm, dz=5mm

Reference Value = 12.08 V/m; Power Drift = 0.09 dB

Peak SAR (extrapolated) = 1.01 W/kg

SAR(1 g) = 0.519 W/kg; SAR(10 g) = 0.250 W/kg

Maximum value of SAR (measured) = 0.635 W/kg

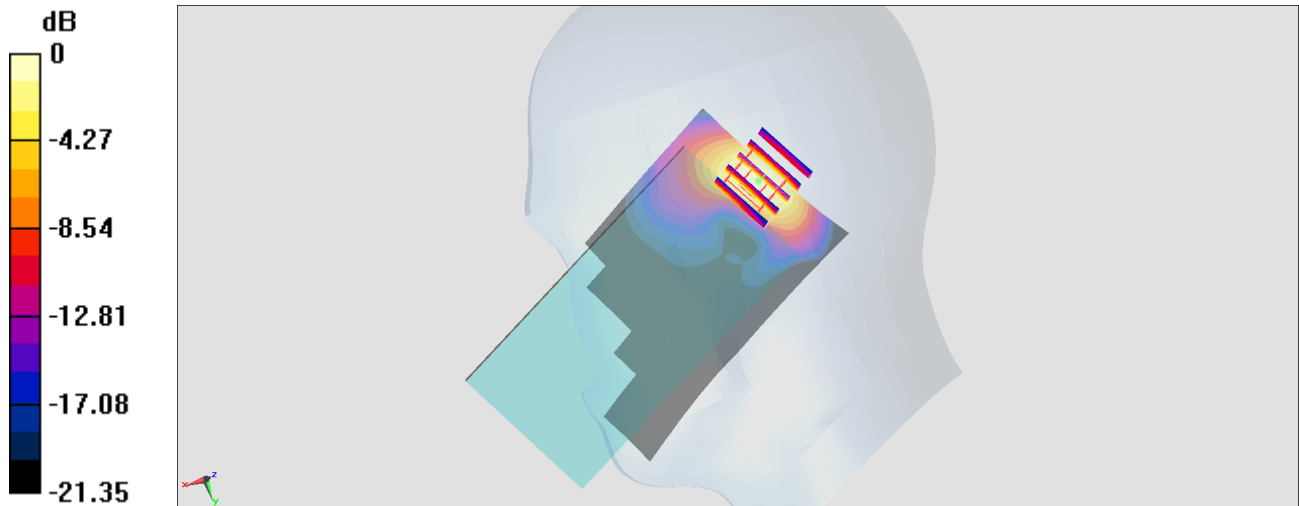

0 dB = 0.635 W/kg = -1.97 dBW/kg

#04_WCDMA V_RMC 12.2Kbps_Right Cheek_Ch4132

Communication System: WCDMA; Frequency: 826.4 MHz; Duty Cycle: 1:1

Medium: HSL_850_180219 Medium parameters used: $f = 826.4$ MHz; $\sigma = 0.886$ S/m; $\epsilon_r = 43.31$; $\rho = 1000$ kg/m³

Ambient Temperature : 23.5 °C ; Liquid Temperature : 22.5 °C

DASY5 Configuration:

- Probe: ES3DV3 - SN3169; ConvF(5.99, 5.99, 5.99); Calibrated: 2017/5/11;
- Sensor-Surface: 3mm (Mechanical Surface Detection)
- Electronics: DAE3 Sn495; Calibrated: 2017/5/22
- Phantom: SAM_Right; Type: QD000P40CD; Serial: 1884
- Measurement SW: DASY52, Version 52.8 (8); SEMCAD X Version 14.6.10 (7373)

Area Scan (61x121x1): Interpolated grid: dx=1.500 mm, dy=1.500 mm

Maximum value of SAR (interpolated) = 0.890 W/kg

Zoom Scan (5x5x7)/Cube 0: Measurement grid: dx=8mm, dy=8mm, dz=5mm

Reference Value = 22.48 V/m; Power Drift = -0.01 dB

Peak SAR (extrapolated) = 1.47 W/kg

SAR(1 g) = 0.682 W/kg; SAR(10 g) = 0.351 W/kg

Maximum value of SAR (measured) = 0.915 W/kg

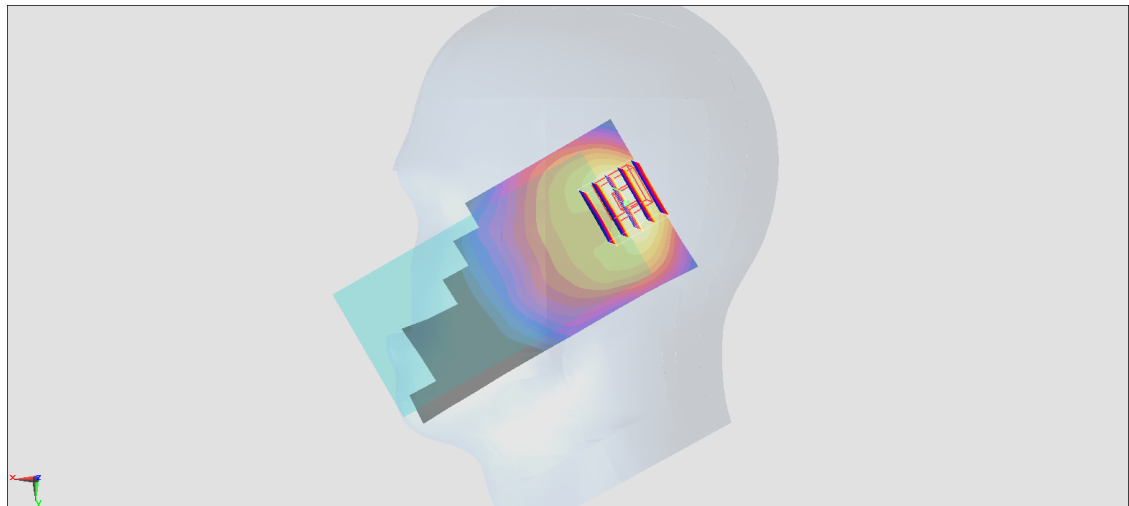
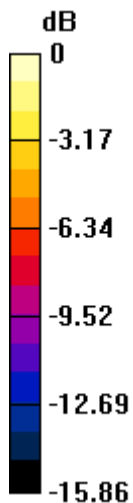

0 dB = 0.915 W/kg = -0.39 dBW/kg

#05_LTE Band 2_20M_QPSK_1_0_Right Tilted_Ch18700

Communication System: LTE ; Frequency: 1860 MHz;Duty Cycle: 1:1

Medium: HSL_1900_180218 Medium parameters used: $f = 1860$ MHz; $\sigma = 1.395$ S/m; $\epsilon_r = 41.162$; $\rho = 1000$ kg/m³

Ambient Temperature : 23.3 °C ; Liquid Temperature : 22.3 °C

DASY5 Configuration:

- Probe: ES3DV3 - SN3169; ConvF(5.03, 5.03, 5.03); Calibrated: 2017/5/11;
- Sensor-Surface: 3mm (Mechanical Surface Detection)
- Electronics: DAE3 Sn495; Calibrated: 2017/5/22
- Phantom: SAM_Right; Type: QD000P40CD; Serial: 1884
- Measurement SW: DASY52, Version 52.8 (8);SEMCAD X Version 14.6.10 (7373)

Area Scan (61x121x1): Interpolated grid: dx=1.500 mm, dy=1.500 mm

Maximum value of SAR (interpolated) = 0.704 W/kg

Zoom Scan (5x5x7)/Cube 0: Measurement grid: dx=8mm, dy=8mm, dz=5mm

Reference Value = 11.19 V/m; Power Drift = 0.10 dB

Peak SAR (extrapolated) = 1.04 W/kg

SAR(1 g) = 0.526 W/kg; SAR(10 g) = 0.246 W/kg

Maximum value of SAR (measured) = 0.655 W/kg

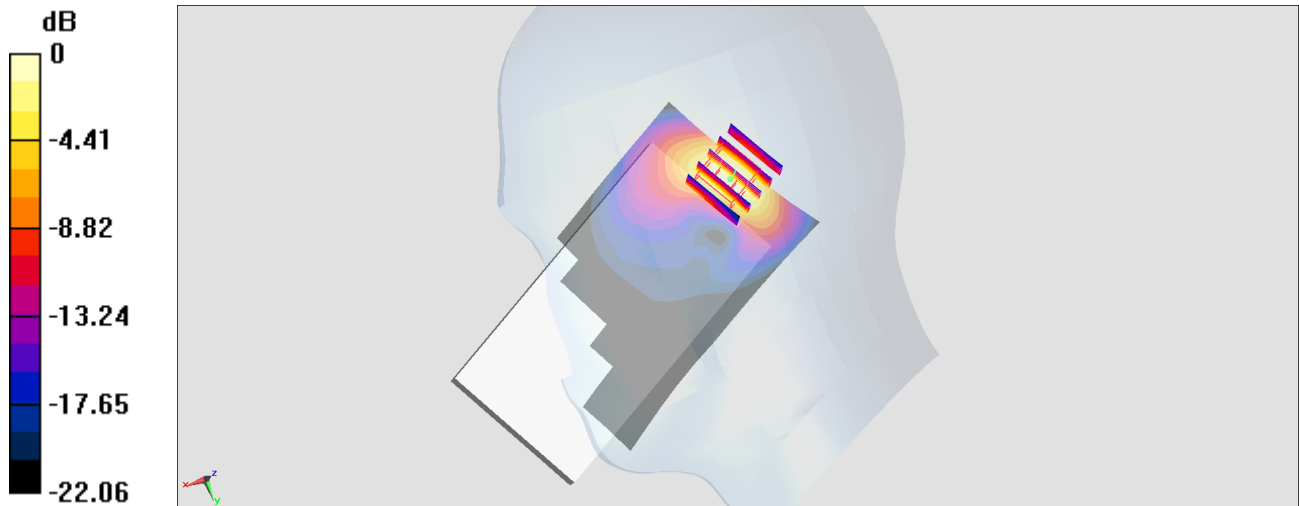

0 dB = 0.655 W/kg = -1.84 dBW/kg

#06_LTE Band 7_20M_QPSK_1_99_Left Tilted_Ch20850

Communication System: LTE; Frequency: 2510 MHz; Duty Cycle: 1:1

Medium: HSL_2600_180221 Medium parameters used: $f = 2510$ MHz; $\sigma = 1.849$ S/m; $\epsilon_r = 38.949$; $\rho = 1000$ kg/m³

Ambient Temperature : 23.6 °C ; Liquid Temperature : 22.6 °C

DASY5 Configuration:

- Probe: ES3DV3 - SN3169; ConvF(4.47, 4.47, 4.47); Calibrated: 2017/5/11;
- Sensor-Surface: 3mm (Mechanical Surface Detection)
- Electronics: DAE3 Sn495; Calibrated: 2017/5/22
- Phantom: SAM_Right; Type: QD000P40CD; Serial: 1884
- Measurement SW: DASY52, Version 52.8 (8); SEMCAD X Version 14.6.10 (7373)

Area Scan (81x151x1): Interpolated grid: dx=1.200 mm, dy=1.200 mm

Maximum value of SAR (interpolated) = 0.630 W/kg

Zoom Scan (7x7x7)/Cube 0: Measurement grid: dx=5mm, dy=5mm, dz=5mm

Reference Value = 11.81 V/m; Power Drift = -0.11 dB

Peak SAR (extrapolated) = 1.42 W/kg

SAR(1 g) = 0.566 W/kg; SAR(10 g) = 0.240 W/kg

Maximum value of SAR (measured) = 0.778 W/kg

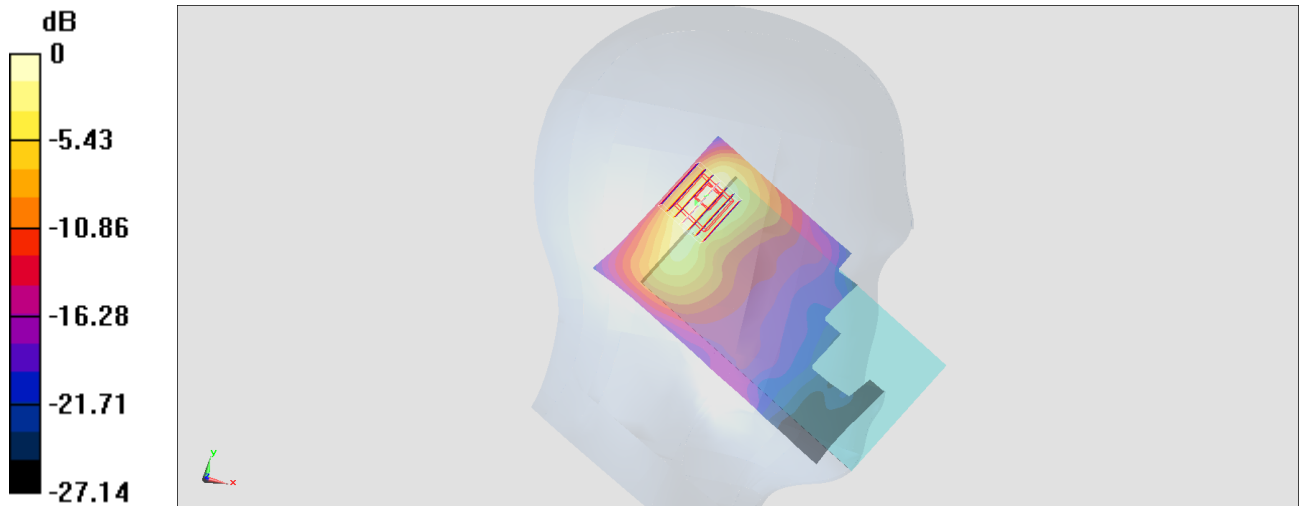

0 dB = 0.778 W/kg = -1.09 dBW/kg

#07_LTE Band 26_15M_QPSK_1_0_Right Cheek_Ch26865

Communication System: LTE; Frequency: 831.5 MHz; Duty Cycle: 1:1

Medium: HSL_850_180219 Medium parameters used: $f = 831.5$ MHz; $\sigma = 0.891$ S/m; $\epsilon_r = 43.246$; $\rho = 1000$ kg/m³

Ambient Temperature : 23.5 °C ; Liquid Temperature : 22.5 °C

DASY5 Configuration:

- Probe: ES3DV3 - SN3169; ConvF(5.99, 5.99, 5.99); Calibrated: 2017/5/11;
- Sensor-Surface: 3mm (Mechanical Surface Detection)
- Electronics: DAE3 Sn495; Calibrated: 2017/5/22
- Phantom: SAM_Right; Type: QD000P40CD; Serial: 1884
- Measurement SW: DASY52, Version 52.8 (8); SEMCAD X Version 14.6.10 (7373)

Area Scan (61x121x1): Interpolated grid: dx=1.500 mm, dy=1.500 mm

Maximum value of SAR (interpolated) = 0.984 W/kg

Zoom Scan (5x5x7)/Cube 0: Measurement grid: dx=8mm, dy=8mm, dz=5mm

Reference Value = 23.73 V/m; Power Drift = -0.01 dB

Peak SAR (extrapolated) = 1.67 W/kg

SAR(1 g) = 0.753 W/kg; SAR(10 g) = 0.384 W/kg

Maximum value of SAR (measured) = 1.02 W/kg

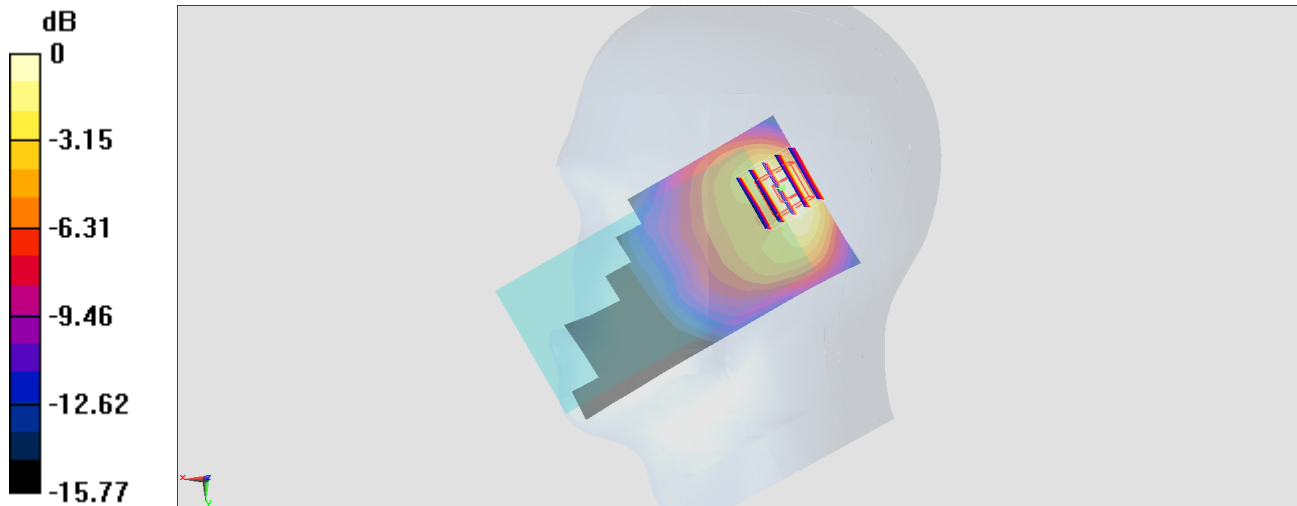

0 dB = 1.02 W/kg = 0.09 dBW/kg

#08_LTE Band 41_20M_QPSK_1_49_Left Tilted_Ch40240

Communication System: LTE; Frequency: 2555 MHz; Duty Cycle: 1:1.59

Medium: HSL_2600_180221 Medium parameters used: $f = 2555$ MHz; $\sigma = 1.901$ S/m; $\epsilon_r = 38.789$; $\rho = 1000$ kg/m³

Ambient Temperature : 23.6 °C ; Liquid Temperature : 22.6 °C

DASY5 Configuration:

- Probe: ES3DV3 - SN3169; ConvF(4.47, 4.47, 4.47); Calibrated: 2017/5/11;
- Sensor-Surface: 3mm (Mechanical Surface Detection)
- Electronics: DAE3 Sn495; Calibrated: 2017/5/22
- Phantom: SAM_Right; Type: QD000P40CD; Serial: 1884
- Measurement SW: DASY52, Version 52.8 (8); SEMCAD X Version 14.6.10 (7373)

Area Scan (81x151x1): Interpolated grid: dx=1.200 mm, dy=1.200 mm

Maximum value of SAR (interpolated) = 0.682 W/kg

Zoom Scan (7x7x7)/Cube 0: Measurement grid: dx=5mm, dy=5mm, dz=5mm

Reference Value = 11.49 V/m; Power Drift = -0.01 dB

Peak SAR (extrapolated) = 1.44 W/kg

SAR(1 g) = 0.559 W/kg; SAR(10 g) = 0.238 W/kg

Maximum value of SAR (measured) = 0.805 W/kg

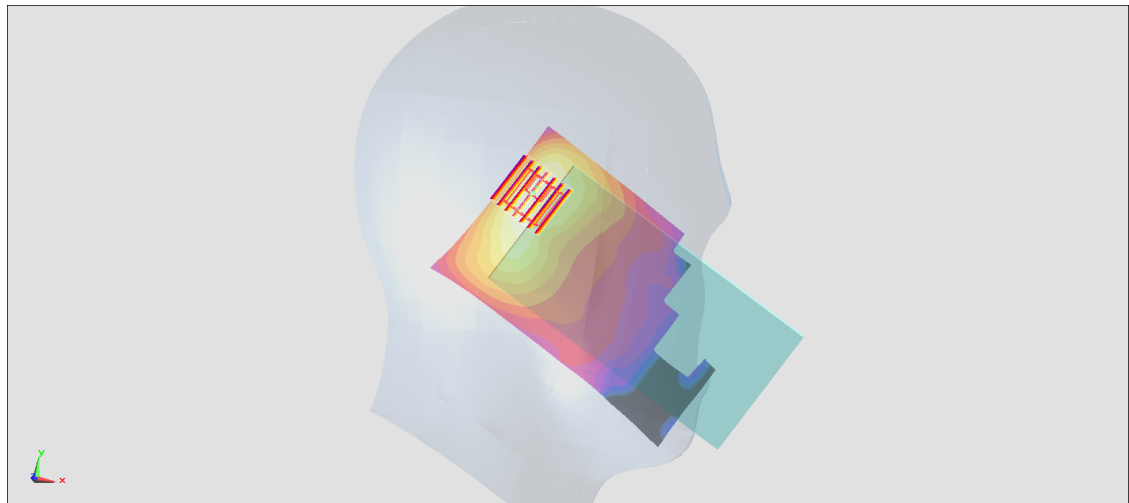
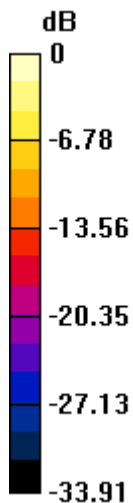

0 dB = 0.805 W/kg = -0.94 dBW/kg

#09_WLAN2.4GHz_802.11b 1Mbps_Right Tilted_Ch6

Communication System: 802.11b; Frequency: 2437 MHz; Duty Cycle: 1:1.015

Medium: HSL_2450_180223 Medium parameters used: $f = 2437$ MHz; $\sigma = 1.759$ S/m; $\epsilon_r = 40.558$; $\rho = 1000$ kg/m³

Ambient Temperature : 23.5 °C ; Liquid Temperature : 22.5 °C

DASY5 Configuration:

- Probe: EX3DV4 - SN3976; ConvF(7.75, 7.75, 7.75); Calibrated: 2018/1/23;
- Sensor-Surface: 1.4mm (Mechanical Surface Detection)
- Electronics: DAE3 Sn495; Calibrated: 2017/5/22
- Phantom: SAM_Right; Type: QD000P40CD; Serial: 1884
- Measurement SW: DASY52, Version 52.8 (8); SEMCAD X Version 14.6.10 (7373)

Area Scan (81x81x1): Interpolated grid: dx=1.200 mm, dy=1.200 mm

Maximum value of SAR (interpolated) = 1.08 W/kg

Zoom Scan (7x7x7)/Cube 0: Measurement grid: dx=5mm, dy=5mm, dz=5mm

Reference Value = 10.31 V/m; Power Drift = 0.11 dB

Peak SAR (extrapolated) = 1.61 W/kg

SAR(1 g) = 0.748 W/kg; SAR(10 g) = 0.348 W/kg

Maximum value of SAR (measured) = 1.27 W/kg

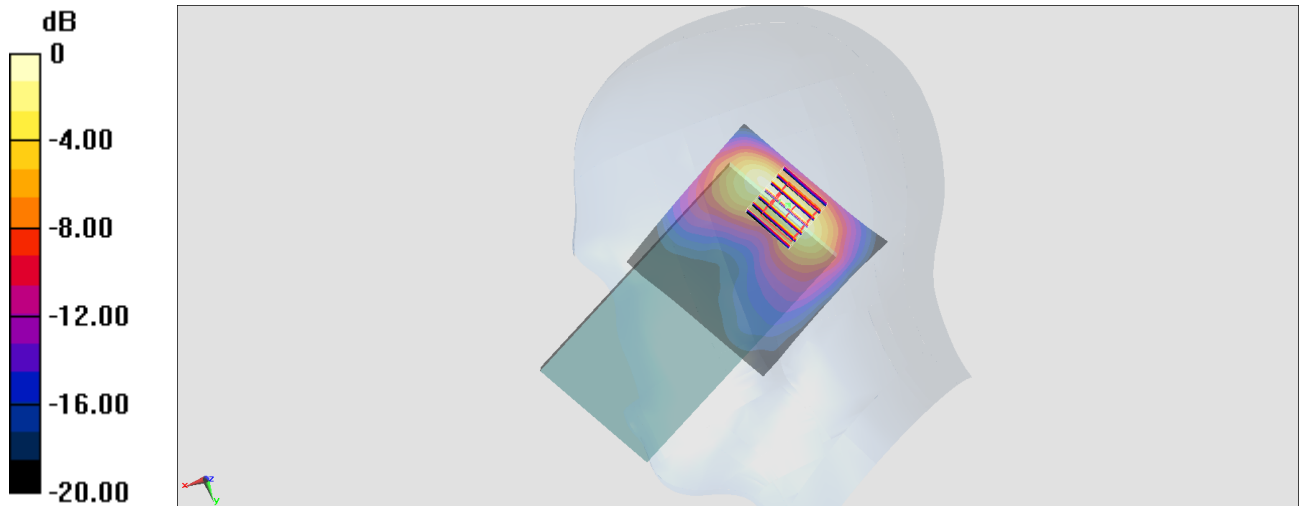

0 dB = 1.27 W/kg = 1.04 dBW/kg

#10_WLAN5GHz_802.11ac-VHT80 MCS0_Right Tilted_Ch58

Communication System: 802.11ac; Frequency: 5290 MHz; Duty Cycle: 1:1.122

Medium: HSL_5G_180223 Medium parameters used: $f = 5290$ MHz; $\sigma = 4.549$ S/m; $\epsilon_r = 35.543$; $\rho = 1000$ kg/m³

Ambient Temperature : 23.5 °C; Liquid Temperature : 22.5 °C

DASY5 Configuration:

- Probe: EX3DV4 - SN3976; ConvF(5.56, 5.56, 5.56); Calibrated: 2018/1/23;
- Sensor-Surface: 1.4mm (Mechanical Surface Detection)
- Electronics: DAE3 Sn495; Calibrated: 2017/5/22
- Phantom: SAM-Left; Type: QD 000 P40 C; Serial: TP-1446
- Measurement SW: DASY52, Version 52.8 (8); SEMCAD X Version 14.6.10 (7373)

Area Scan (101x101x1): Interpolated grid: $dx=1.000$ mm, $dy=1.000$ mm

Maximum value of SAR (interpolated) = 0.809 W/kg

Zoom Scan (7x7x7)/Cube 0: Measurement grid: $dx=4$ mm, $dy=4$ mm, $dz=1.4$ mm

Reference Value = 5.119 V/m; Power Drift = -0.10 dB

Peak SAR (extrapolated) = 1.68 W/kg

SAR(1 g) = 0.309 W/kg; SAR(10 g) = 0.088 W/kg

Maximum value of SAR (measured) = 0.981 W/kg

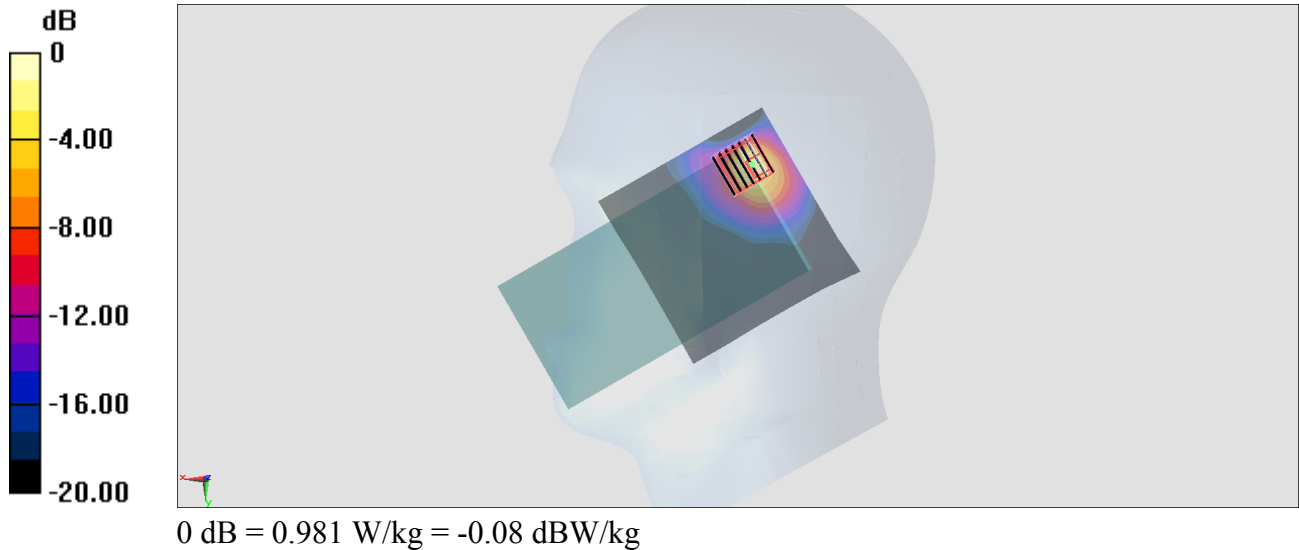

#11_WLAN5GHz_802.11ac-VHT80 MCS0_Right Tilted_Ch138

Communication System: 802.11ac; Frequency: 5610 MHz; Duty Cycle: 1:1.122

Medium: HSL_5G_180223 Medium parameters used: $f = 5610$ MHz; $\sigma = 4.857$ S/m; $\epsilon_r = 35.112$; $\rho = 1000$ kg/m³

Ambient Temperature : 23.5 °C ; Liquid Temperature : 22.5 °C

DASY5 Configuration:

- Probe: EX3DV4 - SN3976; ConvF(4.97, 4.97, 4.97); Calibrated: 2018/1/23;
- Sensor-Surface: 1.4mm (Mechanical Surface Detection)
- Electronics: DAE3 Sn495; Calibrated: 2017/5/22
- Phantom: SAM-Left; Type: QD 000 P40 C; Serial: TP-1446
- Measurement SW: DASY52, Version 52.8 (8); SEMCAD X Version 14.6.10 (7373)

Area Scan (101x101x1): Interpolated grid: $dx=1.000$ mm, $dy=1.000$ mm

Maximum value of SAR (interpolated) = 2.30 W/kg

Zoom Scan (7x7x7)/Cube 0: Measurement grid: $dx=4$ mm, $dy=4$ mm, $dz=1.4$ mm

Reference Value = 8.625 V/m; Power Drift = 0.18 dB

Peak SAR (extrapolated) = 4.89 W/kg

SAR(1 g) = 0.807 W/kg; SAR(10 g) = 0.238 W/kg

Maximum value of SAR (measured) = 2.74 W/kg

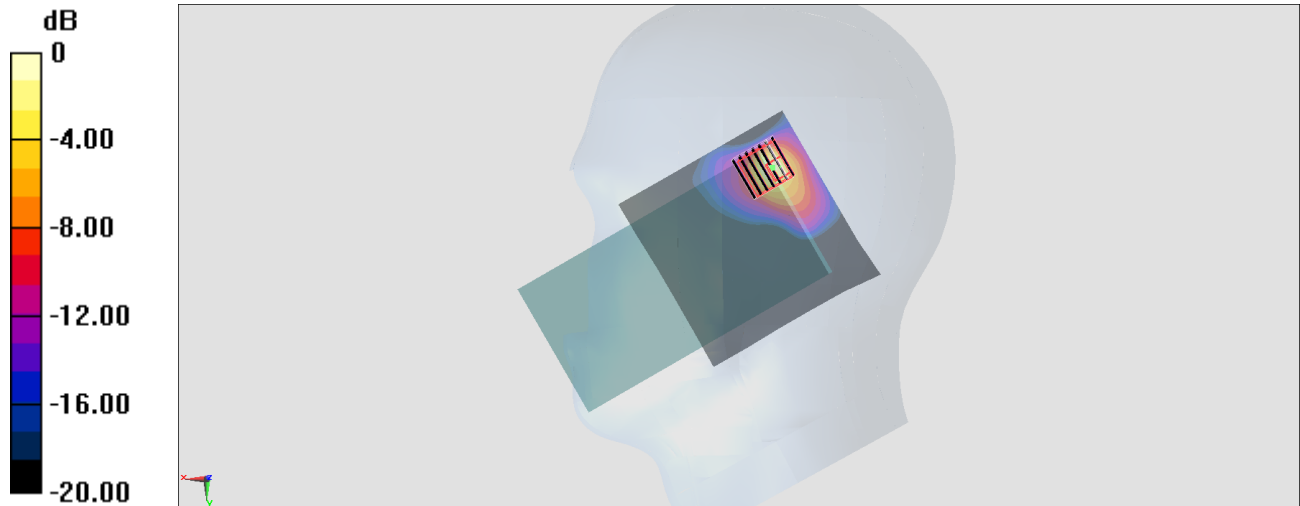

0 dB = 2.74 W/kg = 4.38 dBW/kg

#12_WLAN5GHz_802.11ac-VHT80 MCS0_Right Tilted_Ch155

Communication System: 802.11ac; Frequency: 5775 MHz; Duty Cycle: 1:1.122

Medium: HSL_5G_180223 Medium parameters used: $f = 5775$ MHz; $\sigma = 5.023$ S/m; $\epsilon_r = 34.913$; $\rho = 1000$ kg/m³

Ambient Temperature : 23.5 °C; Liquid Temperature : 22.5 °C

DASY5 Configuration:

- Probe: EX3DV4 - SN3976; ConvF(5.04, 5.04, 5.04); Calibrated: 2018/1/23;
- Sensor-Surface: 1.4mm (Mechanical Surface Detection)
- Electronics: DAE3 Sn495; Calibrated: 2017/5/22
- Phantom: SAM-Left; Type: QD 000 P40 C; Serial: TP-1446
- Measurement SW: DASY52, Version 52.8 (8); SEMCAD X Version 14.6.10 (7373)

Area Scan (101x101x1): Interpolated grid: dx=1.000 mm, dy=1.000 mm

Maximum value of SAR (interpolated) = 1.70 W/kg

Zoom Scan (7x7x7)/Cube 0: Measurement grid: dx=4mm, dy=4mm, dz=1.4mm

Reference Value = 7.054 V/m; Power Drift = 0.12 dB

Peak SAR (extrapolated) = 3.43 W/kg

SAR(1 g) = 0.599 W/kg; SAR(10 g) = 0.169 W/kg

Maximum value of SAR (measured) = 1.81 W/kg

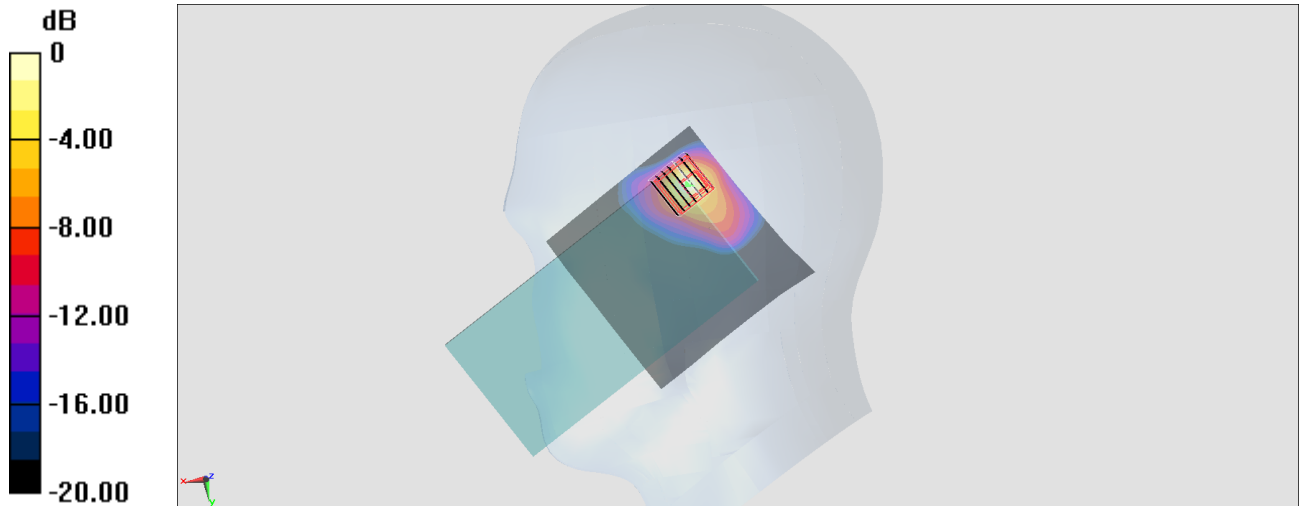

0 dB = 1.81 W/kg = 2.58 dBW/kg

#13_GSM850_GPRS (2 Tx slots)_Right Side_10mm_Ch251

Communication System: GSM850; Frequency: 848.8 MHz; Duty Cycle: 1:4.15

Medium: MSL_850_180220 Medium parameters used: $f = 849$ MHz; $\sigma = 0.988$ S/m; $\epsilon_r = 57.064$; $\rho = 1000$ kg/m³

Ambient Temperature : 23.6 °C ; Liquid Temperature : 22.6 °C

DASY5 Configuration:

- Probe: ES3DV3 - SN3169; ConvF(6.05, 6.05, 6.05); Calibrated: 2017/5/11;
- Sensor-Surface: 3mm (Mechanical Surface Detection)
- Electronics: DAE3 Sn495; Calibrated: 2017/5/22
- Phantom: SAM_Right; Type: QD000P40CD; Serial: 1884
- Measurement SW: DASY52, Version 52.8 (8); SEMCAD X Version 14.6.10 (7373)

Area Scan (41x121x1): Interpolated grid: dx=1.500 mm, dy=1.500 mm

Maximum value of SAR (interpolated) = 0.683 W/kg

Zoom Scan (5x5x7)/Cube 0: Measurement grid: dx=8mm, dy=8mm, dz=5mm

Reference Value = 27.59 V/m; Power Drift = -0.08 dB

Peak SAR (extrapolated) = 0.804 W/kg

SAR(1 g) = 0.592 W/kg; SAR(10 g) = 0.408 W/kg

Maximum value of SAR (measured) = 0.679 W/kg

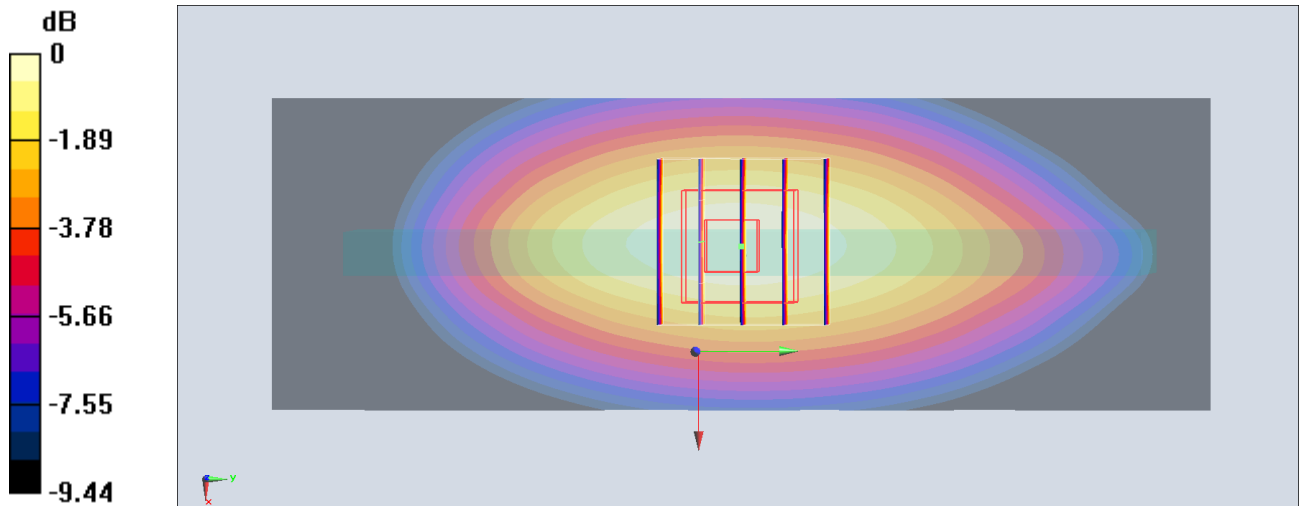

0 dB = 0.679 W/kg = -1.68 dBW/kg

#14_GSM1900_GPRS (2 Tx slots)_Bottom Side_10mm_Ch810

Communication System: PCS; Frequency: 1909.8 MHz; Duty Cycle: 1:4.15

Medium: MSL_1900_180213 Medium parameters used: $f = 1910$ MHz; $\sigma = 1.537$ S/m; $\epsilon_r = 53.157$; $\rho = 1000$ kg/m³

Ambient Temperature : 23.5 °C ; Liquid Temperature : 22.5 °C

DASY5 Configuration:

- Probe: EX3DV4 - SN3931; ConvF(8.12, 8.12, 8.12); Calibrated: 2017/9/29;
- Sensor-Surface: 1.4mm (Mechanical Surface Detection)
- Electronics: DAE4 Sn1399; Calibrated: 2017/11/16
- Phantom: SAM-Left; Type: QD 000 P40 C; Serial: TP-1446
- Measurement SW: DASY52, Version 52.8 (8); SEMCAD X Version 14.6.10 (7373)

Area Scan (41x61x1): Interpolated grid: dx=1.500 mm, dy=1.500 mm

Maximum value of SAR (interpolated) = 1.78 W/kg

Zoom Scan (5x5x7)/Cube 0: Measurement grid: dx=8mm, dy=8mm, dz=5mm

Reference Value = 31.02 V/m; Power Drift = -0.17 dB

Peak SAR (extrapolated) = 1.90 W/kg

SAR(1 g) = 1.12 W/kg; SAR(10 g) = 0.611 W/kg

Maximum value of SAR (measured) = 1.63 W/kg

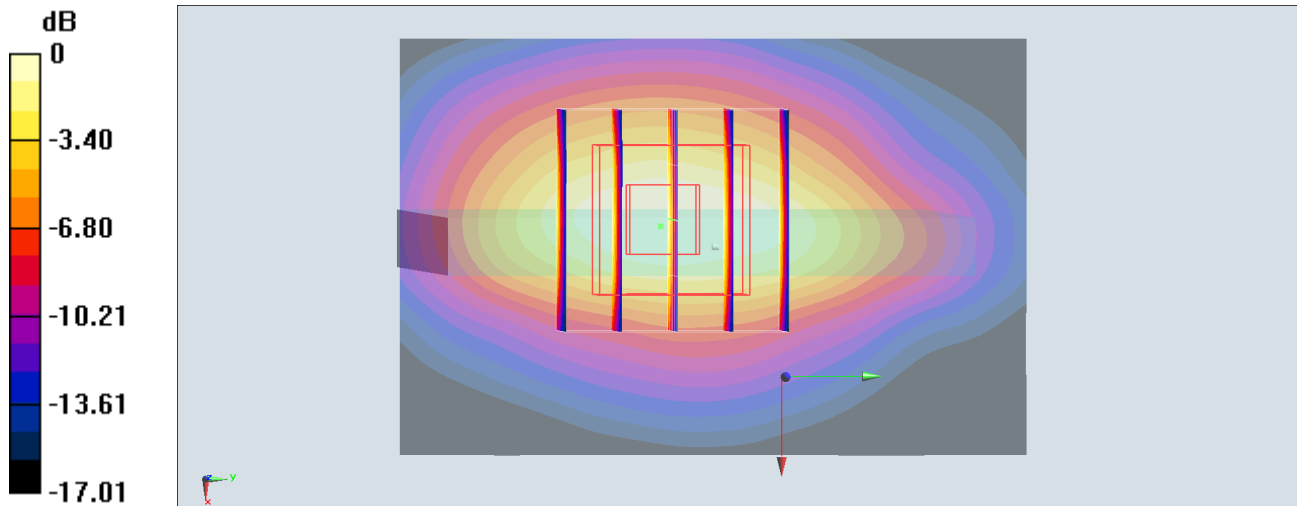

0 dB = 1.63 W/kg = 2.12 dBW/kg

#15_WCDMA II_RMC 12.2Kbps_Bottom Side_10mm_Ch9538

Communication System: WCDMA; Frequency: 1907.6 MHz; Duty Cycle: 1:1

Medium: MSL_1900_180213 Medium parameters used: $f = 1908$ MHz; $\sigma = 1.535$ S/m; $\epsilon_r = 53.166$; $\rho = 1000$ kg/m³

Ambient Temperature : 23.5 °C ; Liquid Temperature : 22.5 °C

DASY5 Configuration:

- Probe: EX3DV4 - SN3931; ConvF(8.12, 8.12, 8.12); Calibrated: 2017/9/29;
- Sensor-Surface: 1.4mm (Mechanical Surface Detection)
- Electronics: DAE4 Sn1399; Calibrated: 2017/11/16
- Phantom: SAM-Left; Type: QD 000 P40 C; Serial: TP-1446
- Measurement SW: DASY52, Version 52.8 (8); SEMCAD X Version 14.6.10 (7373)

Area Scan (41x71x1): Interpolated grid: dx=1.500 mm, dy=1.500 mm

Maximum value of SAR (interpolated) = 1.56 W/kg

Zoom Scan (5x5x7)/Cube 0: Measurement grid: dx=8mm, dy=8mm, dz=5mm

Reference Value = 31.33 V/m; Power Drift = -0.03 dB

Peak SAR (extrapolated) = 1.74 W/kg

SAR(1 g) = 1.02 W/kg; SAR(10 g) = 0.549 W/kg

Maximum value of SAR (measured) = 1.46 W/kg

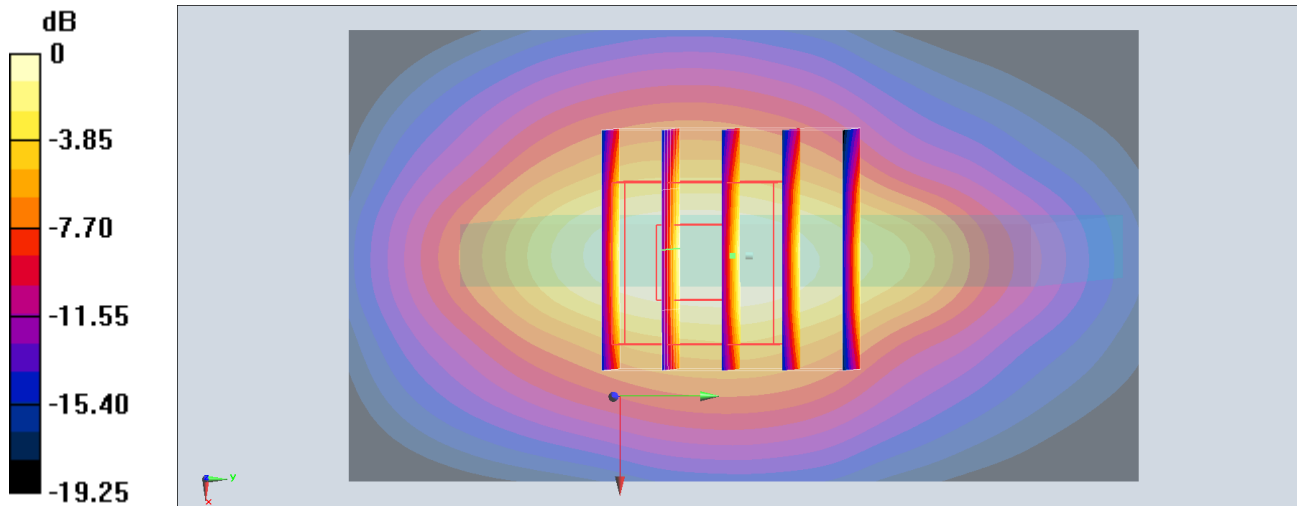

0 dB = 1.46 W/kg = 1.64 dBW/kg

#16_WCDMA V_RMC 12.2Kbps_Back_10mm_Ch4132

Communication System: WCDMA ; Frequency: 826.4 MHz; Duty Cycle: 1:1

Medium: MSL_850_180209 Medium parameters used : $f = 826.4$ MHz; $\sigma = 0.969$ S/m; $\epsilon_r = 55.971$; $\rho = 1000$ kg/m³

Ambient Temperature : 23.4 °C ; Liquid Temperature : 22.4 °C

DASY5 Configuration:

- Probe: ES3DV3 - SN3270; ConvF(6.09, 6.09, 6.09); Calibrated: 2017/9/25;
- Sensor-Surface: 3mm (Mechanical Surface Detection)
- Electronics: DAE4 Sn778; Calibrated: 2017/5/22
- Phantom: SAM_Right; Type: SAM; Serial: TP:1479
- Measurement SW: DASY52, Version 52.8 (8); SEMCAD X Version 14.6.10 (7373)

Area Scan (71x131x1): Interpolated grid: dx=1.500 mm, dy=1.500 mm

Maximum value of SAR (interpolated) = 0.387 W/kg

Zoom Scan (5x5x7)/Cube 0: Measurement grid: dx=8mm, dy=8mm, dz=5mm

Reference Value = 19.10 V/m; Power Drift = -0.06 dB

Peak SAR (extrapolated) = 0.535 W/kg

SAR(1 g) = 0.318 W/kg; SAR(10 g) = 0.190 W/kg

Maximum value of SAR (measured) = 0.384 W/kg

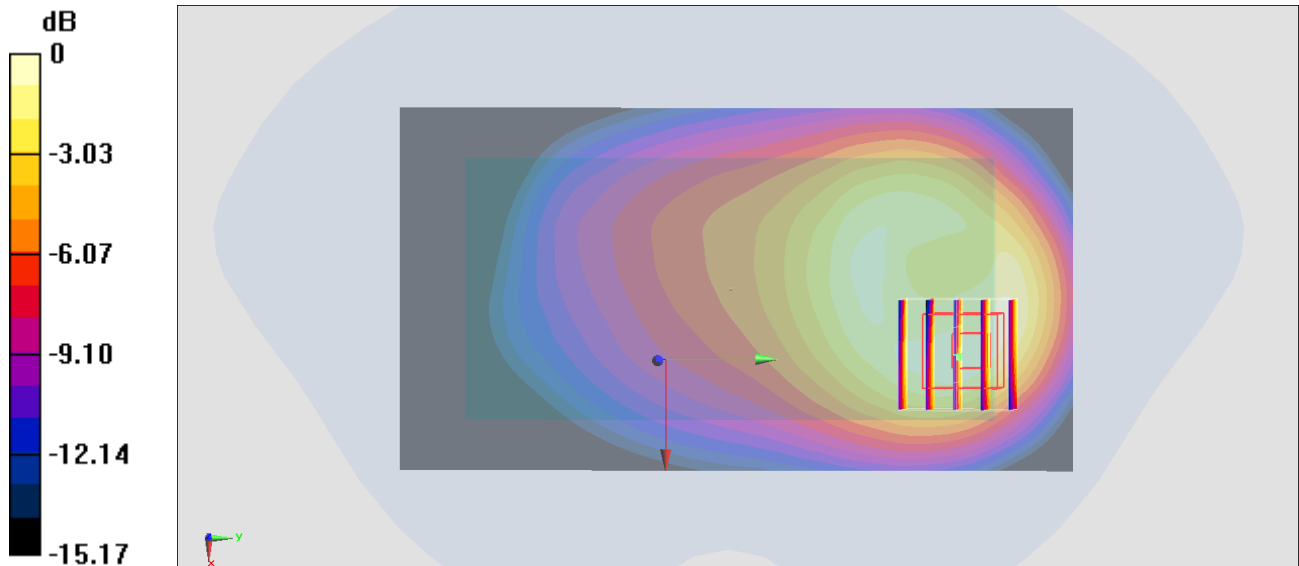

0 dB = 0.384 W/kg = -4.16 dBW/kg

#17_LTE Band 2_20M_QPSK_1_0_Bottom Side_10mm_Ch19100

Communication System: LTE; Frequency: 1900 MHz; Duty Cycle: 1:1

Medium: MSL_1900_180213 Medium parameters used: $f = 1900$ MHz; $\sigma = 1.525$ S/m; $\epsilon_r = 53.202$; $\rho = 1000$ kg/m³

Ambient Temperature : 23.5 °C; Liquid Temperature : 22.5 °C

DASY5 Configuration:

- Probe: EX3DV4 - SN3931; ConvF(8.12, 8.12, 8.12); Calibrated: 2017/9/29;
- Sensor-Surface: 1.4mm (Mechanical Surface Detection)
- Electronics: DAE4 Sn1399; Calibrated: 2017/11/16
- Phantom: SAM-Left; Type: QD 000 P40 C; Serial: TP-1446
- Measurement SW: DASY52, Version 52.8 (8); SEMCAD X Version 14.6.10 (7373)

Area Scan (41x61x1): Interpolated grid: dx=1.500 mm, dy=1.500 mm

Maximum value of SAR (interpolated) = 1.54 W/kg

Zoom Scan (5x5x7)/Cube 0: Measurement grid: dx=8mm, dy=8mm, dz=5mm

Reference Value = 16.35 V/m; Power Drift = -0.01 dB

Peak SAR (extrapolated) = 1.62 W/kg

SAR(1 g) = 0.961 W/kg; SAR(10 g) = 0.523 W/kg

Maximum value of SAR (measured) = 1.38 W/kg

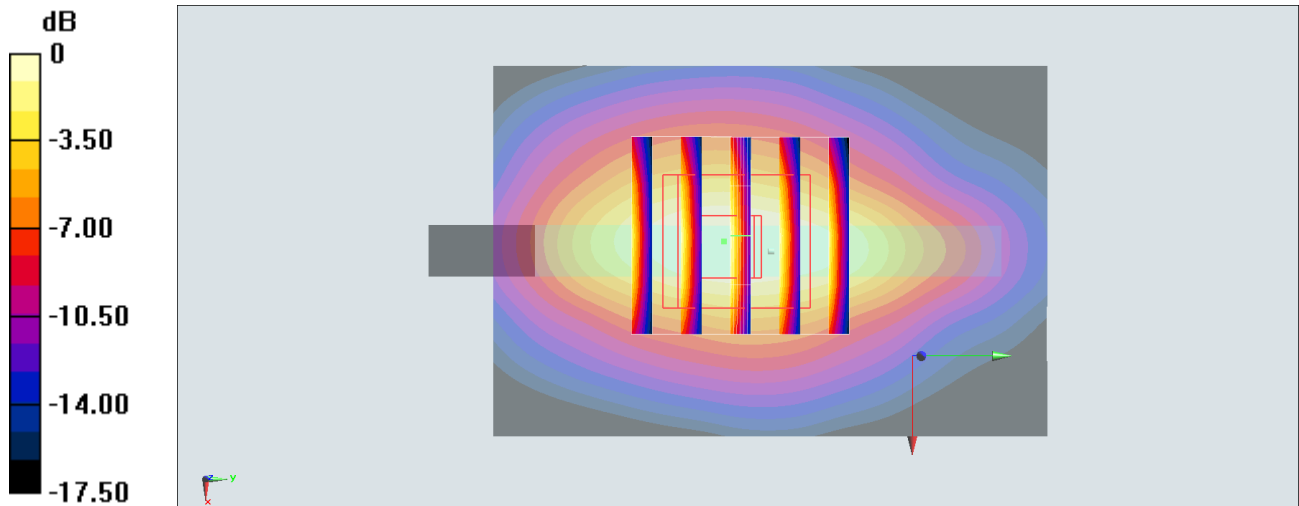

#18_LTE Band 7_20M_QPSK_1_99_Left Side_10mm_Ch21100

Communication System: LTE; Frequency: 2535 MHz; Duty Cycle: 1:1

Medium: MSL_2600_180220 Medium parameters used: $f = 2535$ MHz; $\sigma = 2.086$ S/m; $\epsilon_r = 53.223$; $\rho = 1000$ kg/m³

Ambient Temperature : 23.6 °C ; Liquid Temperature : 22.6 °C

DASY5 Configuration:

- Probe: ES3DV3 - SN3169; ConvF(4.17, 4.17, 4.17); Calibrated: 2017/5/11;
- Sensor-Surface: 3mm (Mechanical Surface Detection)
- Electronics: DAE3 Sn495; Calibrated: 2017/5/22
- Phantom: SAM-Left; Type: QD 000 P40 C; Serial: TP-1446
- Measurement SW: DASY52, Version 52.8 (8); SEMCAD X Version 14.6.10 (7373)

Area Scan (51x151x1): Interpolated grid: dx=1.200 mm, dy=1.200 mm

Maximum value of SAR (interpolated) = 0.588 W/kg

Zoom Scan (7x7x7)/Cube 0: Measurement grid: dx=5mm, dy=5mm, dz=5mm

Reference Value = 17.10 V/m; Power Drift = 0.10 dB

Peak SAR (extrapolated) = 0.900 W/kg

SAR(1 g) = 0.461 W/kg; SAR(10 g) = 0.227 W/kg

Maximum value of SAR (measured) = 0.592 W/kg

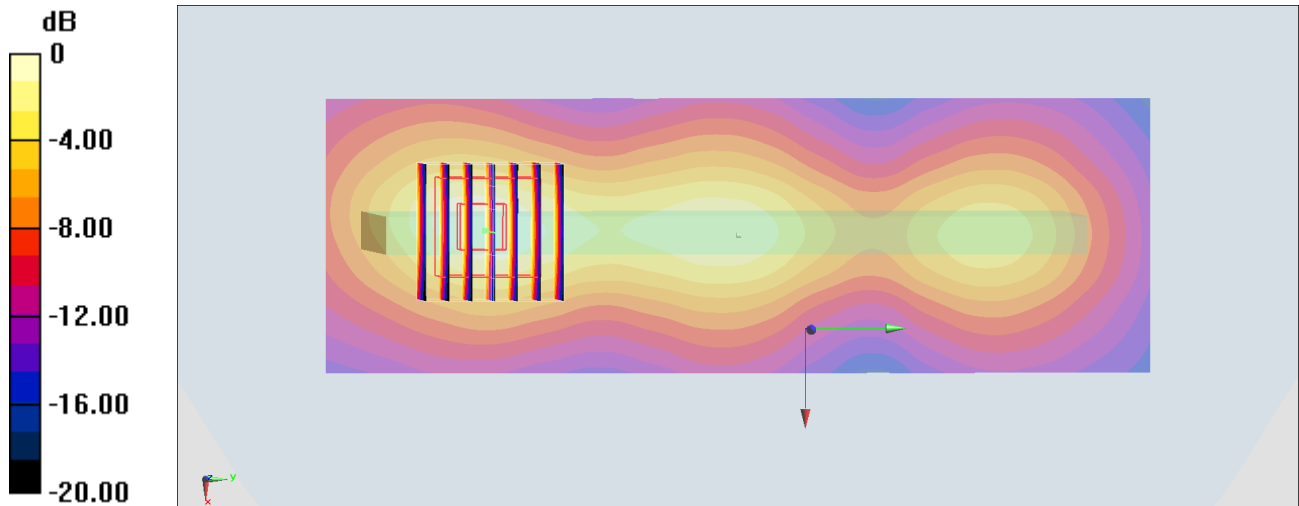

0 dB = 0.592 W/kg = -2.28 dBW/kg

#19_LTE Band 26_15M_QPSK_1_0_Back_10mm_Ch26865

Communication System: LTE; Frequency: 831.5 MHz; Duty Cycle: 1:1

Medium: MSL_850_180220 Medium parameters used (interpolated): $f = 831.5$ MHz; $\sigma = 0.972$ S/m; $\epsilon_r = 57.227$; $\rho = 1000$ kg/m³

Ambient Temperature : 23.6 °C ; Liquid Temperature : 22.6 °C

DASY5 Configuration:

- Probe: ES3DV3 - SN3169; ConvF(6.05, 6.05, 6.05); Calibrated: 2017/5/11;
- Sensor-Surface: 3mm (Mechanical Surface Detection)
- Electronics: DAE3 Sn495; Calibrated: 2017/5/22
- Phantom: SAM_Right; Type: QD000P40CD; Serial: 1884
- Measurement SW: DASY52, Version 52.8 (8); SEMCAD X Version 14.6.10 (7373)

Area Scan (71x81x1): Interpolated grid: dx=1.500 mm, dy=1.500 mm

Maximum value of SAR (interpolated) = 0.373 W/kg

Zoom Scan (5x5x7)/Cube 0: Measurement grid: dx=8mm, dy=8mm, dz=5mm

Reference Value = 15.55 V/m; Power Drift = 0.12 dB

Peak SAR (extrapolated) = 0.482 W/kg

SAR(1 g) = 0.298 W/kg; SAR(10 g) = 0.180 W/kg

Maximum value of SAR (measured) = 0.366 W/kg

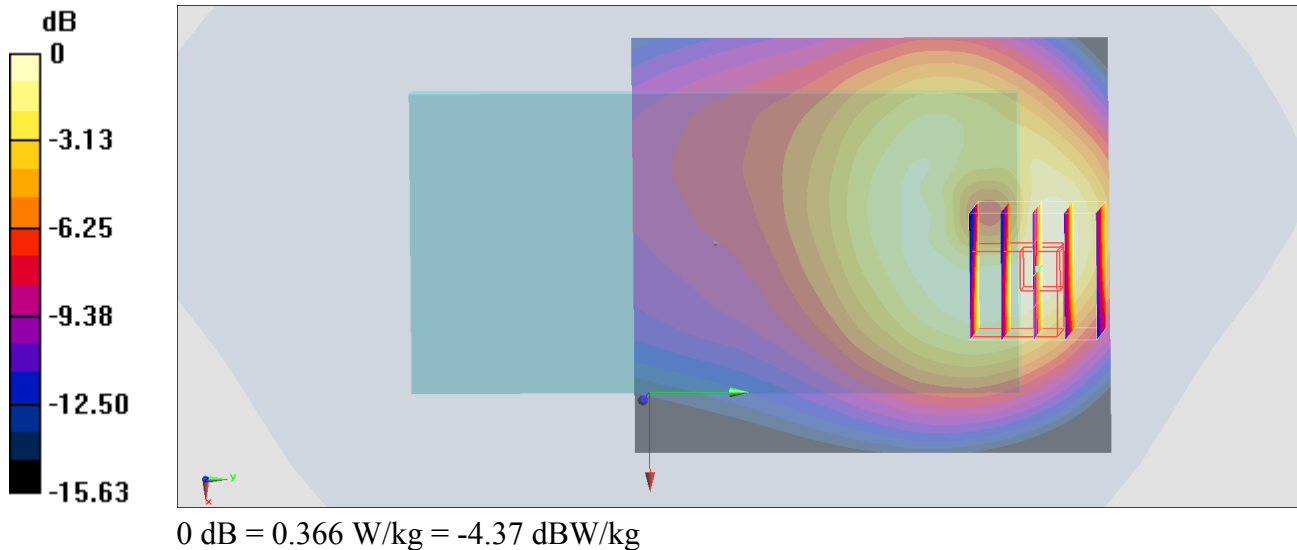

#20_LTE Band 41_20M_QPSK_1_0_Left Side_10mm_Ch40500

Communication System: LTE; Frequency: 2581 MHz; Duty Cycle: 1:1.59

Medium: MSL_2600_180220 Medium parameters used: $f = 2581$ MHz; $\sigma = 2.15$ S/m; $\epsilon_r = 53.097$; $\rho = 1000$ kg/m³

Ambient Temperature : 23.6 °C ; Liquid Temperature : 22.6 °C

DASY5 Configuration:

- Probe: ES3DV3 - SN3169; ConvF(4.17, 4.17, 4.17); Calibrated: 2017/5/11;
- Sensor-Surface: 3mm (Mechanical Surface Detection)
- Electronics: DAE3 Sn495; Calibrated: 2017/5/22
- Phantom: SAM-Left; Type: QD 000 P40 C; Serial: TP-1446
- Measurement SW: DASY52, Version 52.8 (8); SEMCAD X Version 14.6.10 (7373)

Area Scan (51x151x1): Interpolated grid: dx=1.200 mm, dy=1.200 mm

Maximum value of SAR (interpolated) = 0.412 W/kg

Zoom Scan (7x7x7)/Cube 0: Measurement grid: dx=5mm, dy=5mm, dz=5mm

Reference Value = 14.14 V/m; Power Drift = 0.14 dB

Peak SAR (extrapolated) = 0.627 W/kg

SAR(1 g) = 0.317 W/kg; SAR(10 g) = 0.154 W/kg

Maximum value of SAR (measured) = 0.408 W/kg

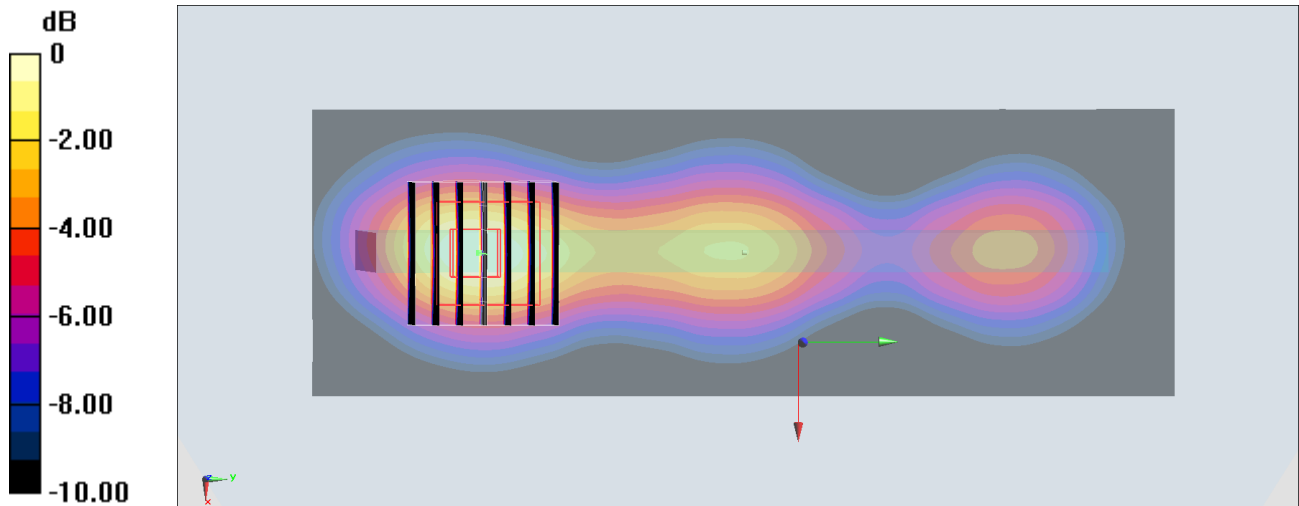

0 dB = 0.408 W/kg = -3.89 dBW/kg

#21_WLAN2.4GHz_802.11b 1Mbps_Top Side_10mm_Ch1

Communication System: 802.11b; Frequency: 2412 MHz; Duty Cycle: 1:1.015

Medium: MSL_2450_180221 Medium parameters used: $f = 2412$ MHz; $\sigma = 1.975$ S/m; $\epsilon_r = 53.43$; $\rho = 1000$ kg/m³

Ambient Temperature : 23.6 °C ; Liquid Temperature : 22.6 °C

DASY5 Configuration:

- Probe: ES3DV3 - SN3169; ConvF(4.28, 4.28, 4.28); Calibrated: 2017/5/11;
- Sensor-Surface: 3mm (Mechanical Surface Detection)
- Electronics: DAE3 Sn495; Calibrated: 2017/5/22
- Phantom: SAM-Left; Type: QD 000 P40 C; Serial: TP-1446
- Measurement SW: DASY52, Version 52.8 (8); SEMCAD X Version 14.6.10 (7373)

Area Scan (51x81x1): Interpolated grid: dx=1.200 mm, dy=1.200 mm

Maximum value of SAR (interpolated) = 0.497 W/kg

Zoom Scan (7x7x7)/Cube 0: Measurement grid: dx=5mm, dy=5mm, dz=5mm

Reference Value = 16.41 V/m; Power Drift = -0.04 dB

Peak SAR (extrapolated) = 0.702 W/kg

SAR(1 g) = 0.382 W/kg; SAR(10 g) = 0.195 W/kg

Maximum value of SAR (measured) = 0.493 W/kg

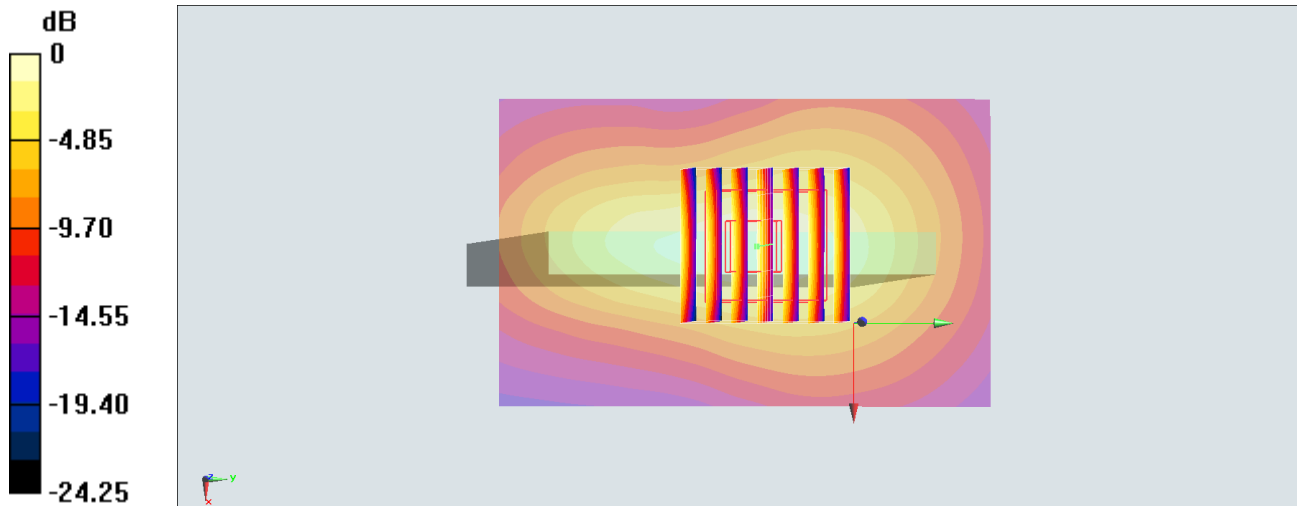

0 dB = 0.493 W/kg = -3.07 dBW/kg

#22_WLAN5GHz_802.11n-HT40 MCS0_Back_10mm_Ch46

Communication System: 802.11n; Frequency: 5230 MHz; Duty Cycle: 1:1.105

Medium: MSL_5G_180222 Medium parameters used: $f = 5230$ MHz; $\sigma = 5.42$ S/m; $\epsilon_r = 46.801$; $\rho = 1000$ kg/m³

Ambient Temperature : 23.5 °C ; Liquid Temperature : 22.5 °C

DASY5 Configuration:

- Probe: EX3DV4 - SN3976; ConvF(4.92, 4.92, 4.92); Calibrated: 2018/1/23;
- Sensor-Surface: 1.4mm (Mechanical Surface Detection)
- Electronics: DAE3 Sn495; Calibrated: 2017/5/22
- Phantom: SAM-Left; Type: QD 000 P40 C; Serial: TP-1446
- Measurement SW: DASY52, Version 52.8 (8); SEMCAD X Version 14.6.10 (7373)

Area Scan (101x121x1): Interpolated grid: dx=1.000 mm, dy=1.000 mm

Maximum value of SAR (interpolated) = 0.348 W/kg

Zoom Scan (7x7x7)/Cube 0: Measurement grid: dx=4mm, dy=4mm, dz=1.4mm

Reference Value = 8.074 V/m; Power Drift = -0.11 dB

Peak SAR (extrapolated) = 0.603 W/kg

SAR(1 g) = 0.149 W/kg; SAR(10 g) = 0.048 W/kg

Maximum value of SAR (measured) = 0.343 W/kg

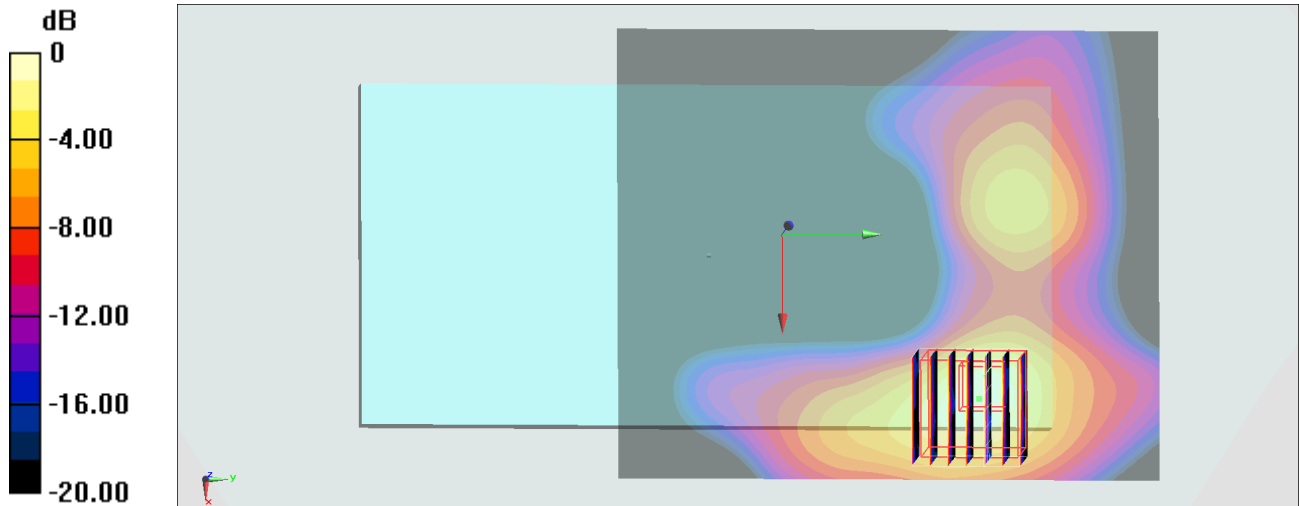

0 dB = 0.343 W/kg = -4.65 dBW/kg

#23_WLAN5GHz_802.11n-HT40 MCS0_Back_10mm_Ch151

Communication System: 802.11n; Frequency: 5755 MHz; Duty Cycle: 1:1.105

Medium: MSL_5G_180222 Medium parameters used: $f = 5755$ MHz; $\sigma = 6.11$ S/m; $\epsilon_r = 45.931$; $\rho = 1000$ kg/m³

Ambient Temperature : 23.5 °C ; Liquid Temperature : 22.5 °C

DASY5 Configuration:

- Probe: EX3DV4 - SN3976; ConvF(4.46, 4.46, 4.46); Calibrated: 2018/1/23;
- Sensor-Surface: 1.4mm (Mechanical Surface Detection)
- Electronics: DAE3 Sn495; Calibrated: 2017/5/22
- Phantom: SAM-Left; Type: QD 000 P40 C; Serial: TP-1446
- Measurement SW: DASY52, Version 52.8 (8); SEMCAD X Version 14.6.10 (7373)

Area Scan (101x81x1): Interpolated grid: dx=1.000 mm, dy=1.000 mm

Maximum value of SAR (interpolated) = 0.324 W/kg

Zoom Scan (7x7x7)/Cube 0: Measurement grid: dx=4mm, dy=4mm, dz=1.4mm

Reference Value = 8.217 V/m; Power Drift = -0.07 dB

Peak SAR (extrapolated) = 0.545 W/kg

SAR(1 g) = 0.123 W/kg; SAR(10 g) = 0.039 W/kg

Maximum value of SAR (measured) = 0.328 W/kg

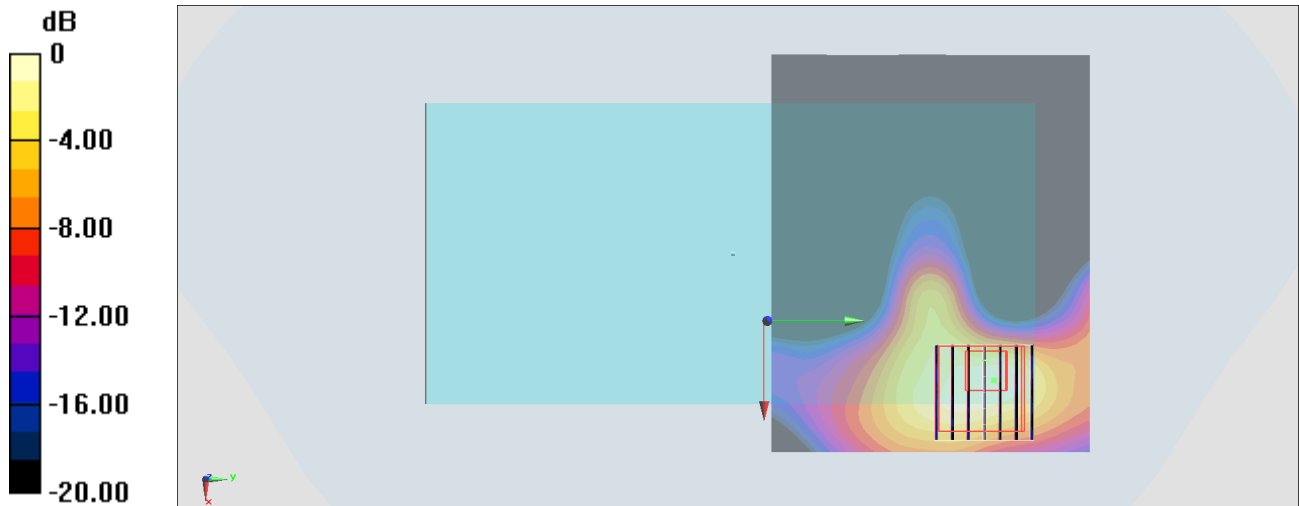

0 dB = 0.328 W/kg = -4.84 dBW/kg

#24_WLAN5GHz_802.11n-HT40 MCS0_Back_0mm_Ch54

Communication System: 802.11n; Frequency: 5270 MHz; Duty Cycle: 1:1.105

Medium: MSL_5G_180222 Medium parameters used: $f = 5270$ MHz; $\sigma = 5.47$ S/m; $\epsilon_r = 46.73$; $\rho = 1000$ kg/m³

Ambient Temperature : 23.5 °C ; Liquid Temperature : 22.5 °C

DASY5 Configuration:

- Probe: EX3DV4 - SN3976; ConvF(4.92, 4.92, 4.92); Calibrated: 2018/1/23;
- Sensor-Surface: 1.4mm (Mechanical Surface Detection)
- Electronics: DAE3 Sn495; Calibrated: 2017/5/22
- Phantom: SAM-Left; Type: QD 000 P40 C; Serial: TP-1446
- Measurement SW: DASY52, Version 52.8 (8); SEMCAD X Version 14.6.10 (7373)

Area Scan (101x201x1): Interpolated grid: $dx=1.000$ mm, $dy=1.000$ mm

Maximum value of SAR (interpolated) = 3.92 W/kg

Zoom Scan (7x7x7)/Cube 0: Measurement grid: $dx=4$ mm, $dy=4$ mm, $dz=1.4$ mm

Reference Value = 28.03 V/m; Power Drift = 0.17 dB

Peak SAR (extrapolated) = 10.2 W/kg

SAR(1 g) = 1.86 W/kg; SAR(10 g) = 0.499 W/kg

Maximum value of SAR (measured) = 4.80 W/kg

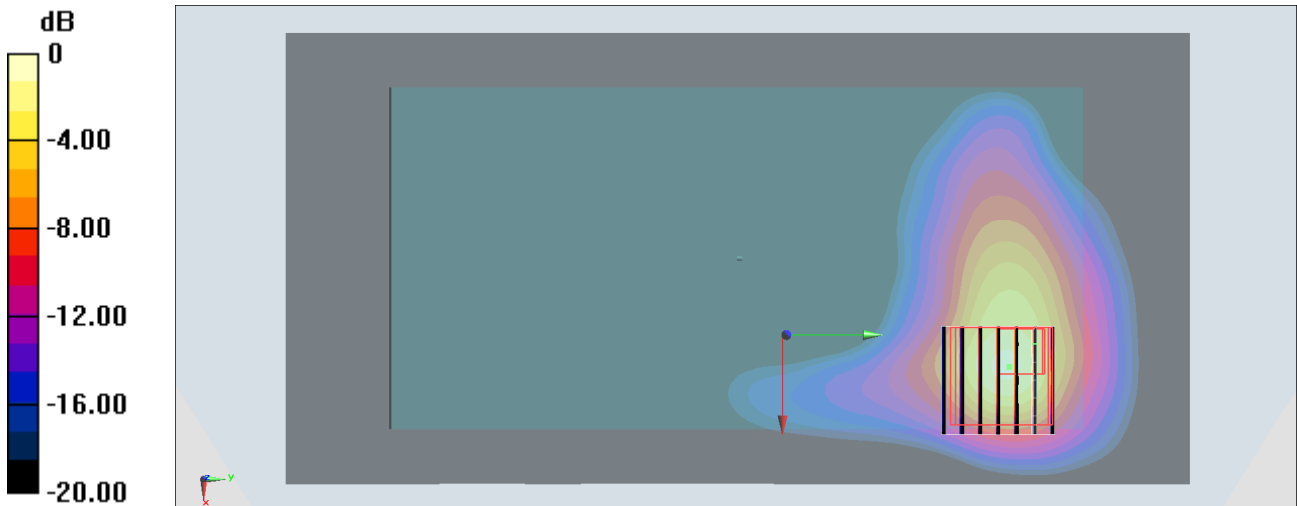

0 dB = 4.80 W/kg = 6.81 dBW/kg

#25_WLAN5GHz_802.11n-HT40 MCS0_Back_0mm_Ch110

Communication System: 802.11n; Frequency: 5550 MHz; Duty Cycle: 1:1.105

Medium: MSL_5G_180222 Medium parameters used: $f = 5550$ MHz; $\sigma = 5.833$ S/m; $\epsilon_r = 46.26$; $\rho = 1000$ kg/m³

Ambient Temperature : 23.5 °C ; Liquid Temperature : 22.5 °C

DASY5 Configuration:

- Probe: EX3DV4 - SN3976; ConvF(4.28, 4.28, 4.28); Calibrated: 2018/1/23;
- Sensor-Surface: 1.4mm (Mechanical Surface Detection)
- Electronics: DAE3 Sn495; Calibrated: 2017/5/22
- Phantom: SAM-Left; Type: QD 000 P40 C; Serial: TP-1446
- Measurement SW: DASY52, Version 52.8 (8); SEMCAD X Version 14.6.10 (7373)

Area Scan (101x121x1): Interpolated grid: dx=1.000 mm, dy=1.000 mm

Maximum value of SAR (interpolated) = 6.76 W/kg

Zoom Scan (7x7x7)/Cube 0: Measurement grid: dx=4mm, dy=4mm, dz=1.4mm

Reference Value = 32.37 V/m; Power Drift = -0.15 dB

Peak SAR (extrapolated) = 20.1 W/kg

SAR(1 g) = 3.21 W/kg; SAR(10 g) = 0.830 W/kg

Maximum value of SAR (measured) = 9.34 W/kg

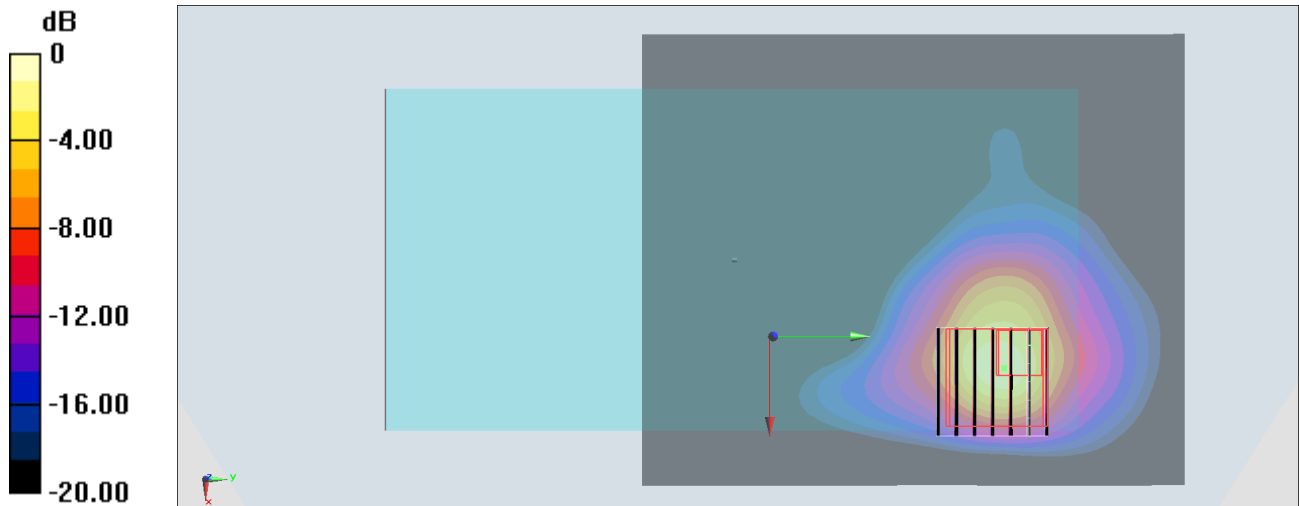

0 dB = 9.34 W/kg = 9.70 dBW/kg

#26_GSM850_GPRS (2 Tx slots)_Back_15mm_Ch251

Communication System: GSM850; Frequency: 848.8 MHz; Duty Cycle: 1:4.15

Medium: MSL_850_180220 Medium parameters used: $f = 849$ MHz; $\sigma = 0.988$ S/m; $\epsilon_r = 57.064$; $\rho = 1000$ kg/m³

Ambient Temperature : 23.6 °C ; Liquid Temperature : 22.6 °C

DASY5 Configuration:

- Probe: ES3DV3 - SN3169; ConvF(6.05, 6.05, 6.05); Calibrated: 2017/5/11;
- Sensor-Surface: 3mm (Mechanical Surface Detection)
- Electronics: DAE3 Sn495; Calibrated: 2017/5/22
- Phantom: SAM_Right; Type: QD000P40CD; Serial: 1884
- Measurement SW: DASY52, Version 52.8 (8); SEMCAD X Version 14.6.10 (7373)

Area Scan (71x121x1): Interpolated grid: dx=1.500 mm, dy=1.500 mm

Maximum value of SAR (interpolated) = 0.382 W/kg

Zoom Scan (5x5x7)/Cube 0: Measurement grid: dx=8mm, dy=8mm, dz=5mm

Reference Value = 20.30 V/m; Power Drift = 0.01 dB

Peak SAR (extrapolated) = 0.432 W/kg

SAR(1 g) = 0.349 W/kg; SAR(10 g) = 0.270 W/kg

Maximum value of SAR (measured) = 0.380 W/kg

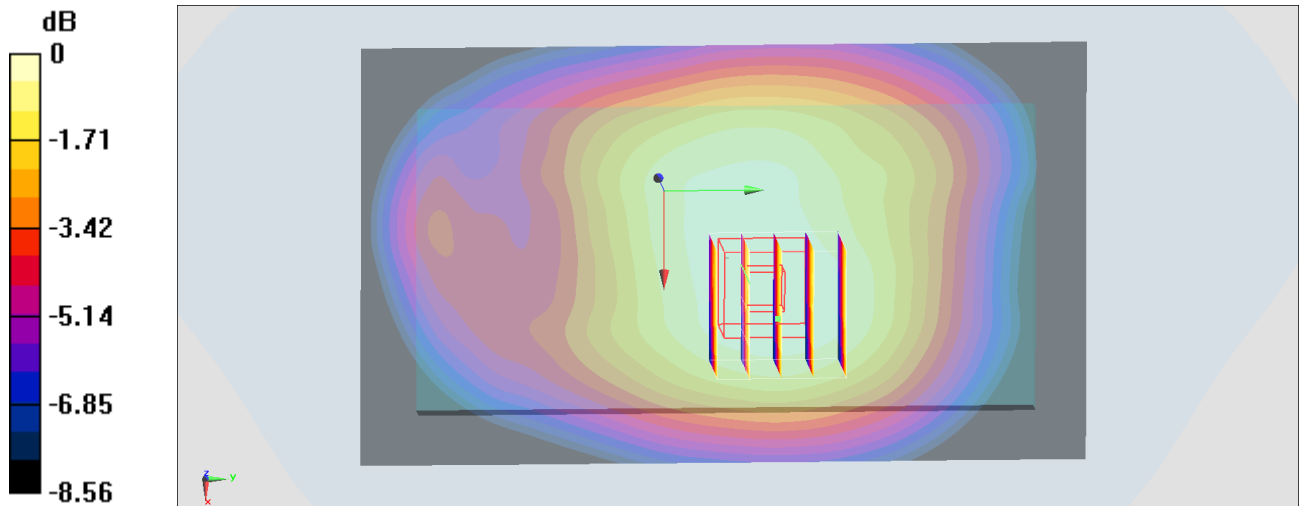

0 dB = 0.380 W/kg = -4.20 dBW/kg

#27_GSM1900_GPRS (2 Tx slots)_Back_15mm_Ch810

Communication System: PCS; Frequency: 1909.8 MHz; Duty Cycle: 1:4.15

Medium: MSL_1900_180213 Medium parameters used: $f = 1910$ MHz; $\sigma = 1.537$ S/m; $\epsilon_r = 53.157$; $\rho = 1000$ kg/m³

Ambient Temperature : 23.5 °C ; Liquid Temperature : 22.5 °C

DASY5 Configuration:

- Probe: EX3DV4 - SN3931; ConvF(8.12, 8.12, 8.12); Calibrated: 2017/9/29;
- Sensor-Surface: 1.4mm (Mechanical Surface Detection)
- Electronics: DAE4 Sn1399; Calibrated: 2017/11/16
- Phantom: SAM-Left; Type: QD 000 P40 C; Serial: TP-1446
- Measurement SW: DASY52, Version 52.8 (8); SEMCAD X Version 14.6.10 (7373)

Area Scan (71x61x1): Interpolated grid: dx=1.500 mm, dy=1.500 mm

Maximum value of SAR (interpolated) = 0.506 W/kg

Zoom Scan (5x5x7)/Cube 0: Measurement grid: dx=8mm, dy=8mm, dz=5mm

Reference Value = 17.27 V/m; Power Drift = -0.10 dB

Peak SAR (extrapolated) = 0.585 W/kg

SAR(1 g) = 0.357 W/kg; SAR(10 g) = 0.206 W/kg

Maximum value of SAR (measured) = 0.506 W/kg

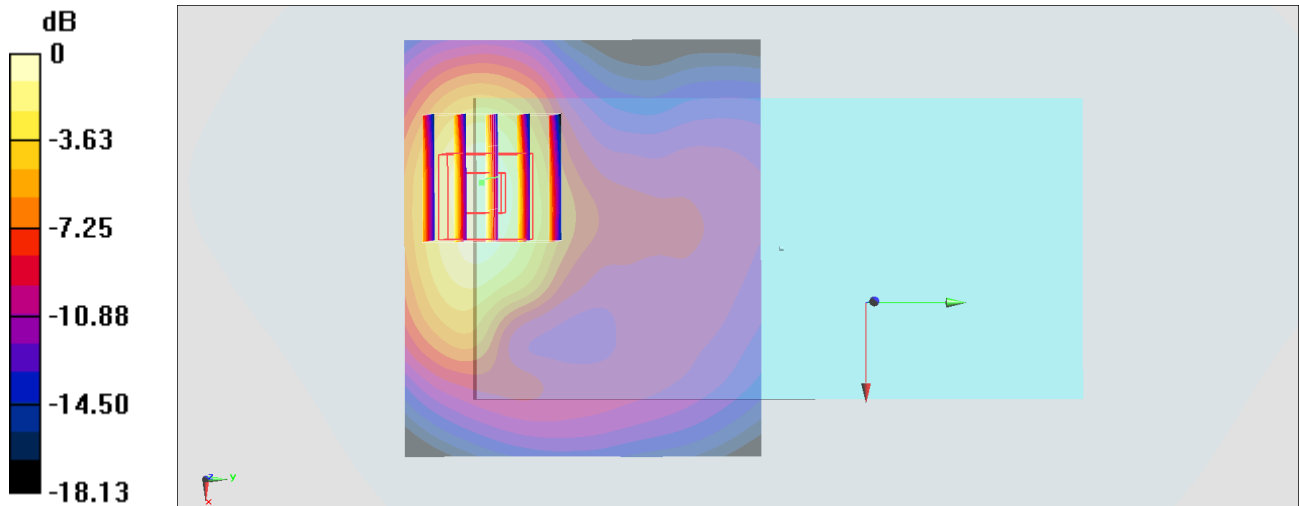

0 dB = 0.506 W/kg = -2.96 dBW/kg

#28_WCDMA II_RMC 12.2Kbps_Back_15mm_Ch9400

Communication System: WCDMA; Frequency: 1880 MHz; Duty Cycle: 1:1

Medium: MSL_1900_180213 Medium parameters used: $f = 1880$ MHz; $\sigma = 1.502$ S/m; $\epsilon_r = 53.293$; $\rho = 1000$ kg/m³

Ambient Temperature : 23.5 °C ; Liquid Temperature : 22.5 °C

DASY5 Configuration:

- Probe: EX3DV4 - SN3931; ConvF(8.12, 8.12, 8.12); Calibrated: 2017/9/29;
- Sensor-Surface: 1.4mm (Mechanical Surface Detection)
- Electronics: DAE4 Sn1399; Calibrated: 2017/11/16
- Phantom: SAM-Left; Type: QD 000 P40 C; Serial: TP-1446
- Measurement SW: DASY52, Version 52.8 (8); SEMCAD X Version 14.6.10 (7373)

Area Scan (61x61x1): Interpolated grid: dx=1.500 mm, dy=1.500 mm

Maximum value of SAR (interpolated) = 0.475 W/kg

Zoom Scan (5x5x7)/Cube 0: Measurement grid: dx=8mm, dy=8mm, dz=5mm

Reference Value = 17.74 V/m; Power Drift = -0.04 dB

Peak SAR (extrapolated) = 0.543 W/kg

SAR(1 g) = 0.331 W/kg; SAR(10 g) = 0.189 W/kg

Maximum value of SAR (measured) = 0.473 W/kg

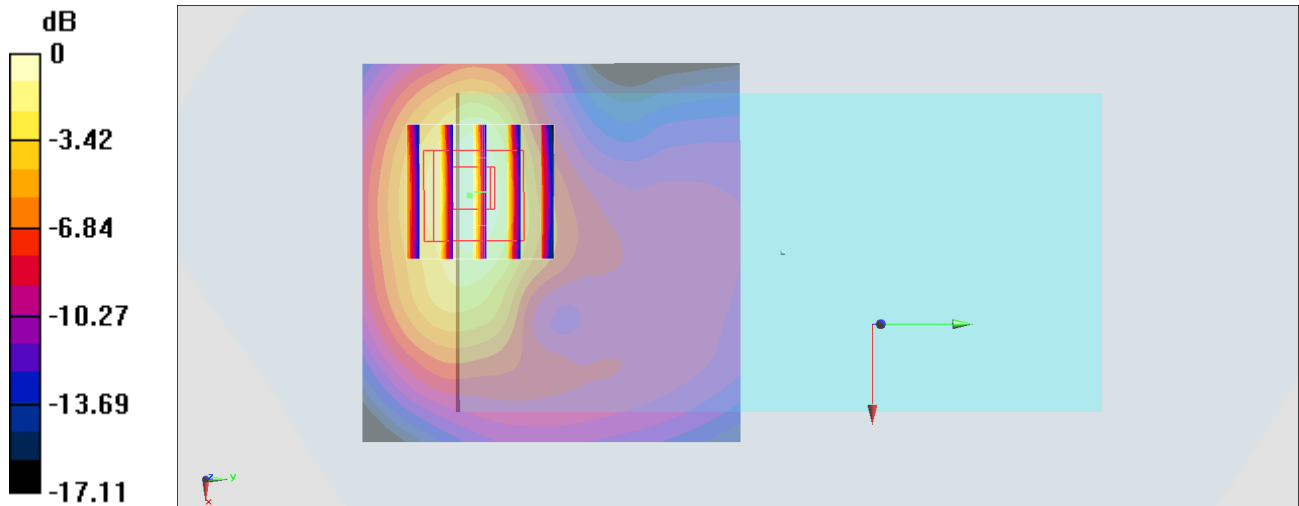

0 dB = 0.473 W/kg = -3.25 dBW/kg

#29_WCDMA V_RMC 12.2Kbps_Back_15mm_Ch4132

Communication System: WCDMA ; Frequency: 826.4 MHz; Duty Cycle: 1:1

Medium: MSL_850_180209 Medium parameters used : $f = 826.4$ MHz; $\sigma = 0.969$ S/m; $\epsilon_r = 55.971$; $\rho = 1000$ kg/m³

Ambient Temperature : 23.4 °C ; Liquid Temperature : 22.4 °C

DASY5 Configuration:

- Probe: ES3DV3 - SN3270; ConvF(6.09, 6.09, 6.09); Calibrated: 2017/9/25;
- Sensor-Surface: 3mm (Mechanical Surface Detection)
- Electronics: DAE4 Sn778; Calibrated: 2017/5/22
- Phantom: SAM_Right; Type: SAM; Serial: TP:1479
- Measurement SW: DASY52, Version 52.8 (8); SEMCAD X Version 14.6.10 (7373)

Area Scan (71x131x1): Interpolated grid: dx=1.500 mm, dy=1.500 mm

Maximum value of SAR (interpolated) = 0.214 W/kg

Zoom Scan (5x5x7)/Cube 0: Measurement grid: dx=8mm, dy=8mm, dz=5mm

Reference Value = 15.33 V/m; Power Drift = 0.02 dB

Peak SAR (extrapolated) = 0.244 W/kg

SAR(1 g) = 0.197 W/kg; SAR(10 g) = 0.153 W/kg

Maximum value of SAR (measured) = 0.213 W/kg

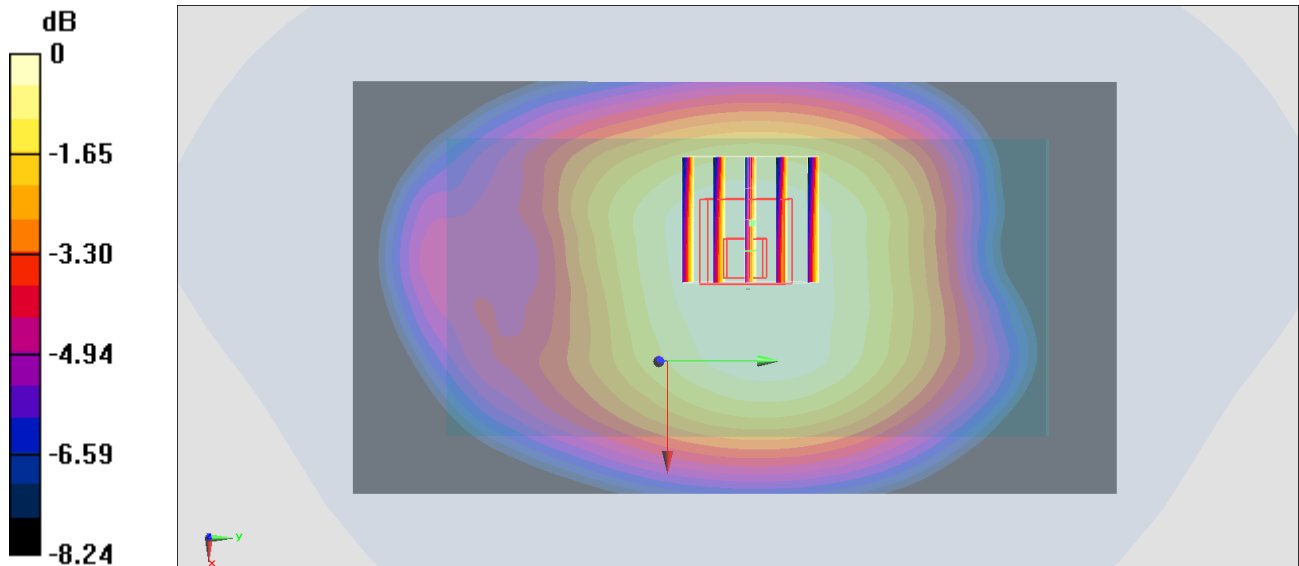

0 dB = 0.213 W/kg = -6.72 dBW/kg

#30_LTE Band 2_20M_QPSK_1_0_Back_15mm_Ch18700

Communication System: LTE; Frequency: 1860 MHz; Duty Cycle: 1:1

Medium: MSL_1900_180213 Medium parameters used: $f = 1860$ MHz; $\sigma = 1.479$ S/m; $\epsilon_r = 53.365$; $\rho = 1000$ kg/m³

Ambient Temperature : 23.5 °C ; Liquid Temperature : 22.5 °C

DASY5 Configuration:

- Probe: EX3DV4 - SN3931; ConvF(8.12, 8.12, 8.12); Calibrated: 2017/9/29;
- Sensor-Surface: 1.4mm (Mechanical Surface Detection)
- Electronics: DAE4 Sn1399; Calibrated: 2017/11/16
- Phantom: SAM-Left; Type: QD 000 P40 C; Serial: TP-1446
- Measurement SW: DASY52, Version 52.8 (8); SEMCAD X Version 14.6.10 (7373)

Area Scan (71x61x1): Interpolated grid: dx=1.500 mm, dy=1.500 mm

Maximum value of SAR (interpolated) = 0.485 W/kg

Zoom Scan (5x5x7)/Cube 0: Measurement grid: dx=8mm, dy=8mm, dz=5mm

Reference Value = 4.595 V/m; Power Drift = 0.07 dB

Peak SAR (extrapolated) = 0.549 W/kg

SAR(1 g) = 0.335 W/kg; SAR(10 g) = 0.191 W/kg

Maximum value of SAR (measured) = 0.471 W/kg

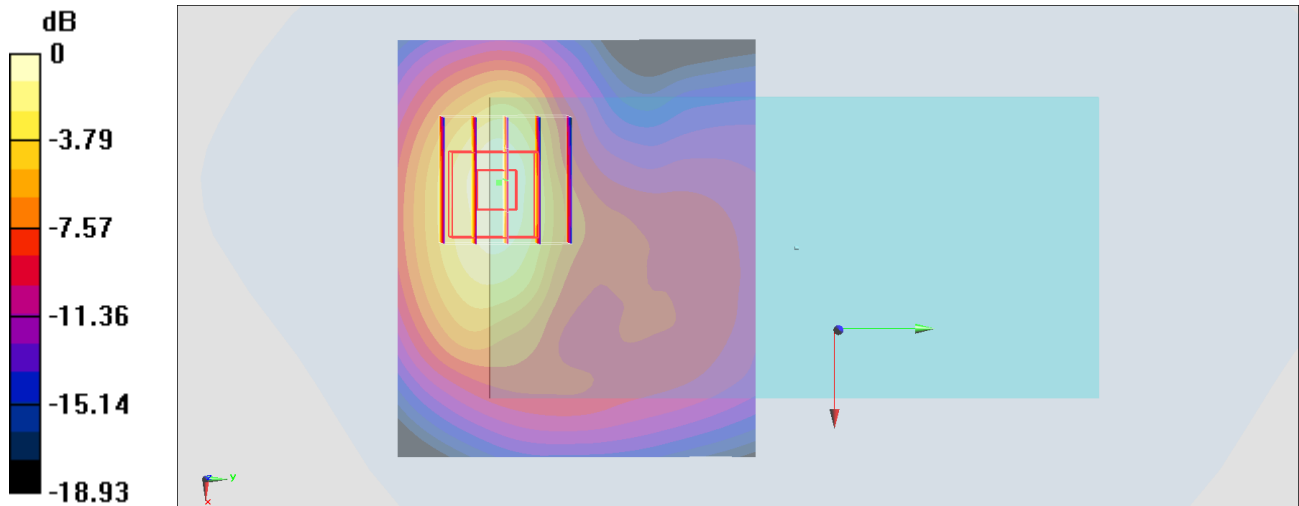

0 dB = 0.471 W/kg = -3.27 dBW/kg

#31_LTE Band 7_20M_QPSK_1_99_Back_15mm_Ch21100

Communication System: LTE; Frequency: 2535 MHz; Duty Cycle: 1:1

Medium: MSL_2600_180220 Medium parameters used (interpolated): $f = 2535$ MHz; $\sigma = 2.086$ S/m; $\epsilon_r = 53.223$; $\rho = 1000$ kg/m³

Ambient Temperature : 23.6 °C ; Liquid Temperature : 22.6 °C

DASY5 Configuration:

- Probe: ES3DV3 - SN3169; ConvF(4.17, 4.17, 4.17); Calibrated: 2017/5/11;
- Sensor-Surface: 3mm (Mechanical Surface Detection)
- Electronics: DAE3 Sn495; Calibrated: 2017/5/22
- Phantom: SAM-Left; Type: QD 000 P40 C; Serial: TP-1446
- Measurement SW: DASY52, Version 52.8 (8); SEMCAD X Version 14.6.10 (7373)

Area Scan (81x81x1): Interpolated grid: dx=1.200 mm, dy=1.200 mm

Maximum value of SAR (interpolated) = 0.194 W/kg

Zoom Scan (7x7x7)/Cube 0: Measurement grid: dx=5mm, dy=5mm, dz=5mm

Reference Value = 9.019 V/m; Power Drift = 0.03 dB

Peak SAR (extrapolated) = 0.290 W/kg

SAR(1 g) = 0.149 W/kg; SAR(10 g) = 0.076 W/kg

Maximum value of SAR (measured) = 0.192 W/kg

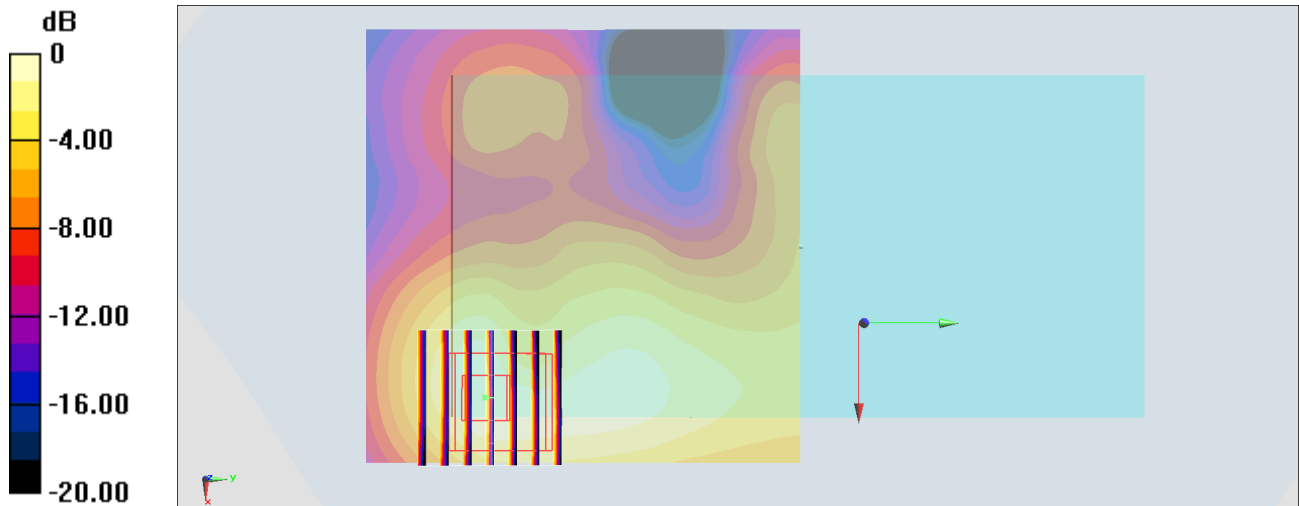

0 dB = 0.192 W/kg = -7.17 dBW/kg

#32_LTE Band 26_15M_QPSK_1_0_Back_15mm_Ch26865

Communication System: LTE; Frequency: 831.5 MHz; Duty Cycle: 1:1

Medium: MSL_850_180220 Medium parameters used: $f = 831.5$ MHz; $\sigma = 0.972$ S/m; $\epsilon_r = 57.227$; $\rho = 1000$ kg/m³

Ambient Temperature : 23.6 °C ; Liquid Temperature : 22.6 °C

DASY5 Configuration:

- Probe: ES3DV3 - SN3169; ConvF(6.05, 6.05, 6.05); Calibrated: 2017/5/11;
- Sensor-Surface: 3mm (Mechanical Surface Detection)
- Electronics: DAE3 Sn495; Calibrated: 2017/5/22
- Phantom: SAM_Right; Type: QD000P40CD; Serial: 1884
- Measurement SW: DASY52, Version 52.8 (8); SEMCAD X Version 14.6.10 (7373)

Area Scan (61x111x1): Interpolated grid: dx=1.500 mm, dy=1.500 mm

Maximum value of SAR (interpolated) = 0.208 W/kg

Zoom Scan (5x5x7)/Cube 0: Measurement grid: dx=8mm, dy=8mm, dz=5mm

Reference Value = 15.12 V/m; Power Drift = -0.00 dB

Peak SAR (extrapolated) = 0.230 W/kg

SAR(1 g) = 0.189 W/kg; SAR(10 g) = 0.147 W/kg

Maximum value of SAR (measured) = 0.206 W/kg

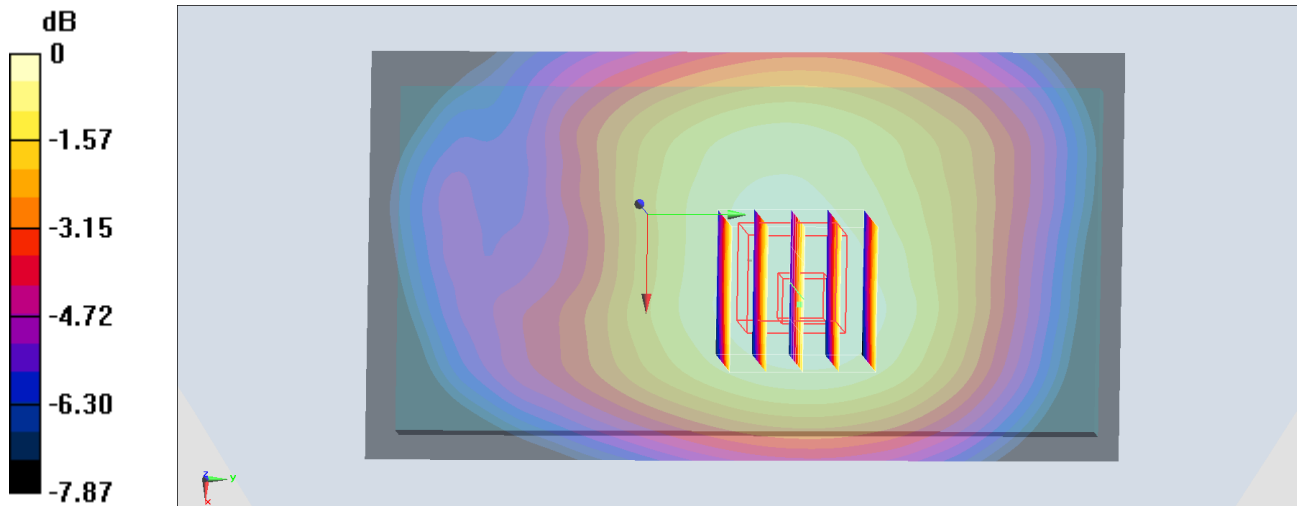

0 dB = 0.206 W/kg = -6.86 dBW/kg

#33_LTE Band 41_20M_QPSK_1_0_Back_15mm_Ch40500

Communication System: LTE; Frequency: 2581 MHz; Duty Cycle: 1:1.59

Medium: MSL_2600_180220 Medium parameters used: $f = 2581$ MHz; $\sigma = 2.15$ S/m; $\epsilon_r = 53.097$; $\rho = 1000$ kg/m³

Ambient Temperature : 23.6 °C ; Liquid Temperature : 22.6 °C

DASY5 Configuration:

- Probe: ES3DV3 - SN3169; ConvF(4.17, 4.17, 4.17); Calibrated: 2017/5/11;
- Sensor-Surface: 3mm (Mechanical Surface Detection)
- Electronics: DAE3 Sn495; Calibrated: 2017/5/22
- Phantom: SAM-Left; Type: QD 000 P40 C; Serial: TP-1446
- Measurement SW: DASY52, Version 52.8 (8); SEMCAD X Version 14.6.10 (7373)

Area Scan (81x81x1): Interpolated grid: dx=1.200 mm, dy=1.200 mm

Maximum value of SAR (interpolated) = 0.120 W/kg

Zoom Scan (7x7x7)/Cube 0: Measurement grid: dx=5mm, dy=5mm, dz=5mm

Reference Value = 6.710 V/m; Power Drift = 0.05 dB

Peak SAR (extrapolated) = 0.190 W/kg

SAR(1 g) = 0.094 W/kg; SAR(10 g) = 0.045 W/kg

Maximum value of SAR (measured) = 0.122 W/kg

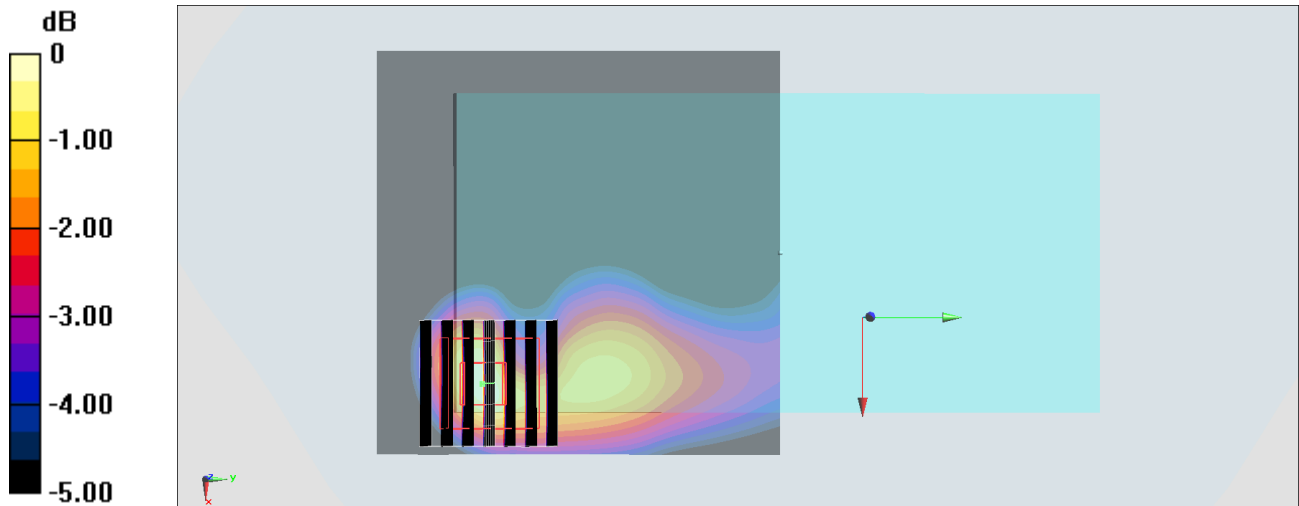

0 dB = 0.122 W/kg = -9.14 dBW/kg

#34_WLAN2.4GHz_802.11b 1Mbps_Back_15mm_Ch1

Communication System: 802.11b; Frequency: 2412 MHz; Duty Cycle: 1:1.015

Medium: MSL_2450_180221 Medium parameters used: $f = 2412$ MHz; $\sigma = 1.975$ S/m; $\epsilon_r = 53.43$; $\rho = 1000$ kg/m³

Ambient Temperature : 23.6 °C ; Liquid Temperature : 22.6 °C

DASY5 Configuration:

- Probe: ES3DV3 - SN3169; ConvF(4.28, 4.28, 4.28); Calibrated: 2017/5/11;
- Sensor-Surface: 3mm (Mechanical Surface Detection)
- Electronics: DAE3 Sn495; Calibrated: 2017/5/22
- Phantom: SAM-Left; Type: QD 000 P40 C; Serial: TP-1446
- Measurement SW: DASY52, Version 52.8 (8); SEMCAD X Version 14.6.10 (7373)

Area Scan (81x81x1): Interpolated grid: dx=1.200 mm, dy=1.200 mm

Maximum value of SAR (interpolated) = 0.169 W/kg

Zoom Scan (7x7x7)/Cube 0: Measurement grid: dx=5mm, dy=5mm, dz=5mm

Reference Value = 9.028 V/m; Power Drift = 0.07 dB

Peak SAR (extrapolated) = 0.230 W/kg

SAR(1 g) = 0.137 W/kg; SAR(10 g) = 0.078 W/kg

Maximum value of SAR (measured) = 0.166 W/kg

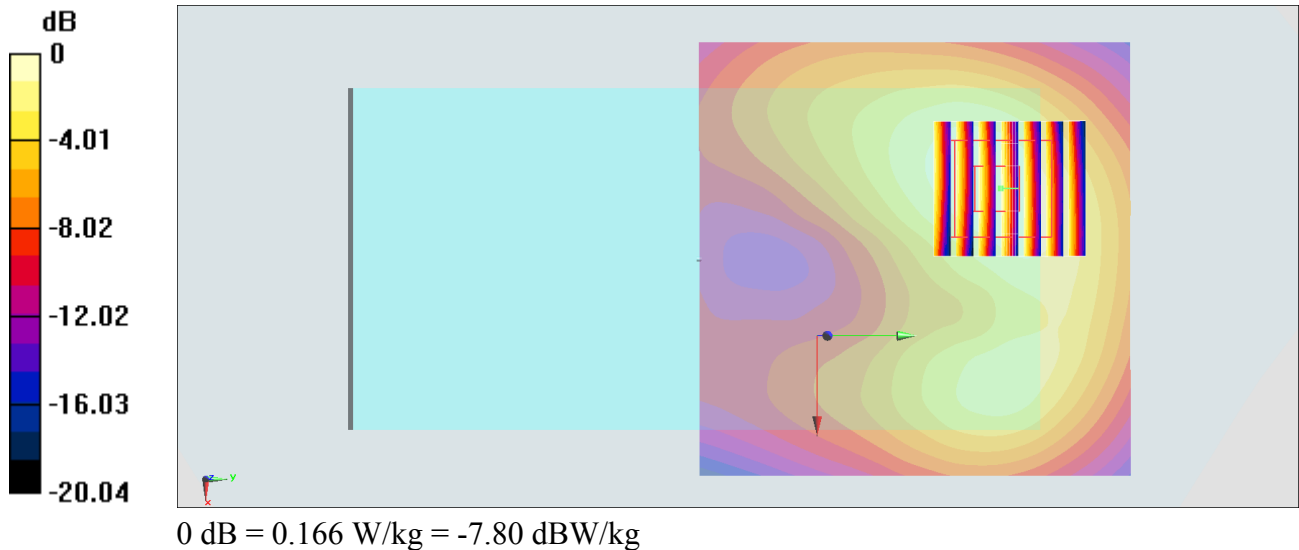

#35_WLAN5GHz_802.11n-HT40 MCS0_Back_15mm_Ch54

Communication System: 802.11n; Frequency: 5270 MHz; Duty Cycle: 1:1.105

Medium: MSL_5G_180222 Medium parameters used: $f = 5270$ MHz; $\sigma = 5.47$ S/m; $\epsilon_r = 46.73$; $\rho = 1000$ kg/m³

Ambient Temperature : 23.5 °C ; Liquid Temperature : 22.5 °C

DASY5 Configuration:

- Probe: EX3DV4 - SN3976; ConvF(4.92, 4.92, 4.92); Calibrated: 2018/1/23;
- Sensor-Surface: 1.4mm (Mechanical Surface Detection)
- Electronics: DAE3 Sn495; Calibrated: 2017/5/22
- Phantom: SAM-Left; Type: QD 000 P40 C; Serial: TP-1446
- Measurement SW: DASY52, Version 52.8 (8); SEMCAD X Version 14.6.10 (7373)

Area Scan (101x101x1): Interpolated grid: dx=1.000 mm, dy=1.000 mm

Maximum value of SAR (interpolated) = 0.132 W/kg

Zoom Scan (7x7x7)/Cube 0: Measurement grid: dx=4mm, dy=4mm, dz=1.4mm

Reference Value = 2.892 V/m; Power Drift = 0.10 dB

Peak SAR (extrapolated) = 0.185 W/kg

SAR(1 g) = 0.043 W/kg; SAR(10 g) = 0.014 W/kg

Maximum value of SAR (measured) = 0.119 W/kg

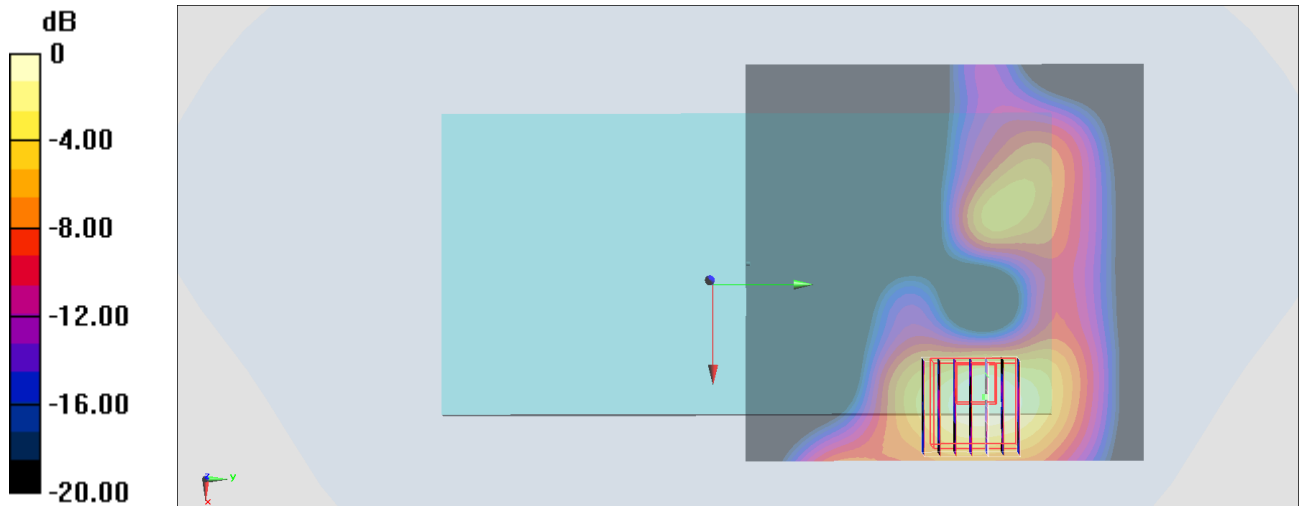

0 dB = 0.119 W/kg = -9.24 dBW/kg

#36_WLAN5GHz_802.11n-HT40 MCS0_Back_15mm_Ch110

Communication System: 802.11n; Frequency: 5550 MHz; Duty Cycle: 1:1.105

Medium: MSL_5G_180222 Medium parameters used: $f = 5550$ MHz; $\sigma = 5.833$ S/m; $\epsilon_r = 46.26$; $\rho = 1000$ kg/m³

Ambient Temperature : 23.5 °C ; Liquid Temperature : 22.5 °C

DASY5 Configuration:

- Probe: EX3DV4 - SN3976; ConvF(4.28, 4.28, 4.28); Calibrated: 2018/1/23;
- Sensor-Surface: 1.4mm (Mechanical Surface Detection)
- Electronics: DAE3 Sn495; Calibrated: 2017/5/22
- Phantom: SAM-Left; Type: QD 000 P40 C; Serial: TP-1446
- Measurement SW: DASY52, Version 52.8 (8); SEMCAD X Version 14.6.10 (7373)

Area Scan (101x121x1): Interpolated grid: dx=1.000 mm, dy=1.000 mm

Maximum value of SAR (interpolated) = 0.259 W/kg

Zoom Scan (7x7x7)/Cube 0: Measurement grid: dx=4mm, dy=4mm, dz=1.4mm

Reference Value = 5.128 V/m; Power Drift = 0.13 dB

Peak SAR (extrapolated) = 0.413 W/kg

SAR(1 g) = 0.104 W/kg; SAR(10 g) = 0.038 W/kg

Maximum value of SAR (measured) = 0.246 W/kg

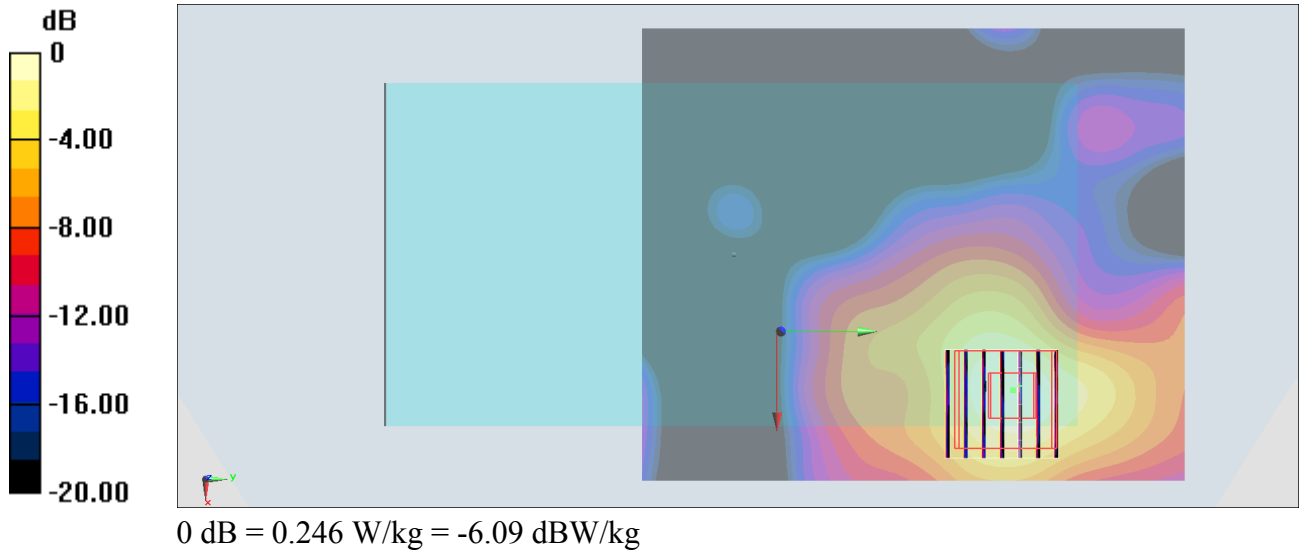

#37_WLAN5GHz_802.11n-HT40 MCS0_Back_15mm_Ch151

Communication System: 802.11n; Frequency: 5755 MHz; Duty Cycle: 1:1.105

Medium: MSL_5G_180222 Medium parameters used: $f = 5755$ MHz; $\sigma = 6.11$ S/m; $\epsilon_r = 45.931$; $\rho = 1000$ kg/m³

Ambient Temperature : 23.5 °C ; Liquid Temperature : 22.5 °C

DASY5 Configuration:

- Probe: EX3DV4 - SN3976; ConvF(4.46, 4.46, 4.46); Calibrated: 2018/1/23;
- Sensor-Surface: 1.4mm (Mechanical Surface Detection)
- Electronics: DAE3 Sn495; Calibrated: 2017/5/22
- Phantom: SAM-Left; Type: QD 000 P40 C; Serial: TP-1446
- Measurement SW: DASY52, Version 52.8 (8); SEMCAD X Version 14.6.10 (7373)

Area Scan (101x81x1): Interpolated grid: dx=1.000 mm, dy=1.000 mm

Maximum value of SAR (interpolated) = 0.222 W/kg

Zoom Scan (7x7x7)/Cube 0: Measurement grid: dx=4mm, dy=4mm, dz=1.4mm

Reference Value = 6.199 V/m; Power Drift = -0.16 dB

Peak SAR (extrapolated) = 0.251 W/kg

SAR(1 g) = 0.062 W/kg; SAR(10 g) = 0.020 W/kg

Maximum value of SAR (measured) = 0.186 W/kg

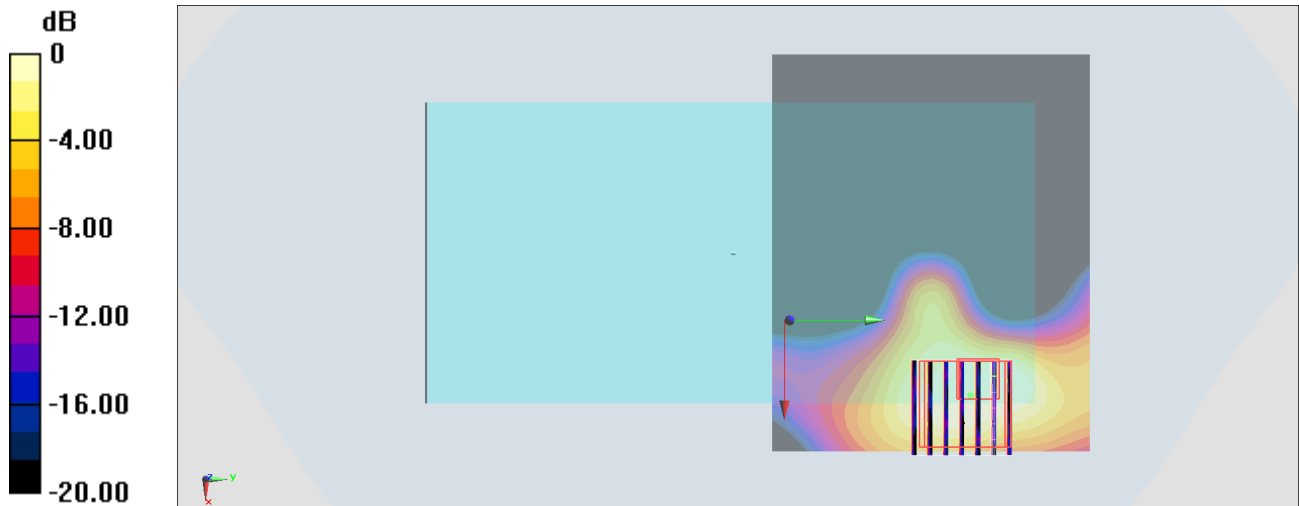

0 dB = 0.186 W/kg = -7.30 dBW/kg