



# FCC RF Test Report

APPLICANT : ASUSTeK COMPUTER INC.  
EQUIPMENT : ASUS Phone (Mobile Phone)  
BRAND NAME : ASUS  
MODEL NAME : ASUS\_X00HD  
MARKETING NAME : ZC520KL  
FCC ID : MSQX00HD  
STANDARD : FCC Part 15 Subpart C §15.247  
CLASSIFICATION : (DTS) Digital Transmission System

The product was received on May 24, 2017 and testing was completed on Aug. 23, 2017. We, Sporton International (Shenzhen) Inc., would like to declare that the tested sample has been evaluated in accordance with the test procedures and has been in compliance with the applicable technical standards.

The test results in this report apply exclusively to the tested model / sample. Without written approval of Sporton International (Shenzhen) Inc., the test report shall not be reproduced except in full.



Approved by: Eric Shih / Manager

**Sporton International (Shenzhen) Inc.**

**1/F, 2/F, Bldg 5, Shiling Industrial Zone, Xinwei Village, Xili, Nanshan Shenzhen City  
Guangdong Province 518055 China**



# TABLE OF CONTENTS

**REVISION HISTORY..... 3**

**SUMMARY OF TEST RESULT ..... 4**

**1 GENERAL DESCRIPTION ..... 5**

    1.1 Applicant ..... 5

    1.2 Manufacturer ..... 5

    1.3 Product Feature of Equipment Under Test..... 5

    1.4 Product Specification of Equipment Under Test..... 6

    1.5 Modification of EUT ..... 6

    1.6 Testing Location ..... 7

    1.7 Applicable Standards..... 8

**2 TEST CONFIGURATION OF EQUIPMENT UNDER TEST ..... 9**

    2.1 Carrier Frequency and Channel ..... 9

    2.2 Test Mode..... 10

    2.3 Connection Diagram of Test System..... 11

    2.4 Support Unit used in test configuration and system ..... 12

    2.5 EUT Operation Test Setup ..... 12

    2.6 Measurement Results Explanation Example..... 13

**3 TEST RESULT ..... 14**

    3.1 6dB and 99% Bandwidth Measurement ..... 14

    3.2 Output Power Measurement..... 16

    3.3 Power Spectral Density Measurement ..... 17

    3.4 Conducted Band Edges and Spurious Emission Measurement ..... 19

    3.5 Radiated Band Edges and Spurious Emission Measurement ..... 32

    3.6 AC Conducted Emission Measurement..... 36

    3.7 Antenna Requirements ..... 40

**4 LIST OF MEASURING EQUIPMENT ..... 41**

**5 UNCERTAINTY OF EVALUATION ..... 42**

**APPENDIX A. CONDUCTED TEST RESULTS**

**APPENDIX B. RADIATED SPURIOUS EMISSION**

**APPENDIX C. DUTY CYCLE PLOTS**

**APPENDIX D. SETUP PHOTOGRAPHS**



### REVISION HISTORY

REPORT NO.	VERSION	DESCRIPTION	ISSUED DATE
FR752406C	Rev. 01	Initial issue of report	Aug. 28, 2017



### SUMMARY OF TEST RESULT

Report Section	FCC Rule	IC Rule	Description	Limit	Result	Remark
3.1	15.247(a)(2)	RSS-247 5.2(a)	6dB Bandwidth	$\geq 0.5\text{MHz}$	Pass	-
3.1	-	RSS-Gen 6.6	99% Bandwidth	-	Pass	-
3.2	15.247(b)	RSS-247 5.4(d)	Power Output Measurement	$\leq 30\text{dBm}$	Pass	-
3.3	15.247(e)	RSS-247 5.2(b)	Power Spectral Density	$\leq 8\text{dBm}/3\text{kHz}$	Pass	-
3.4	15.247(d)	RSS-247 5.5	Conducted Band Edges	$\leq 20\text{dBc}$	Pass	-
			Conducted Spurious Emission		Pass	-
3.5	15.247(d)	RSS-247 5.5	Radiated Band Edges and Radiated Spurious Emission	15.209(a) & 15.247(d)	Pass	Under limit 2.20 dB at 2389.10 MHz
3.6	15.207	RSS-GEN 8.8	AC Conducted Emission	15.207(a)	Pass	Under limit 5.98 dB at 0.15 MHz
3.7	15.203 & 15.247(b)	N/A	Antenna Requirement	N/A	Pass	-



# 1 General Description

## 1.1 Applicant

ASUSTeK COMPUTER INC.

4F, No.150, Li-Te Rd., Peitou, Taipei 112, Taiwan

## 1.2 Manufacturer

ASUSTeK COMPUTER INC.

4F, No.150, Li-Te Rd., Peitou, Taipei 112, Taiwan

## 1.3 Product Feature of Equipment Under Test

Product Feature	
Equipment	ASUS Phone (Mobile Phone)
Brand Name	ASUS
Model Name	ASUS_X00HD
Marketing Name	ZC520KL
FCC ID	MSQX00HD
EUT supports Radios application	GSM/GPRS/EGPRS/WCDMA/HSPA/ DC-HSDPA/HSPA+/LTE/ WLAN 2.4GHz 802.11b/g/n HT20/HT40/ Bluetooth v3.0 + EDR/Bluetooth v4.0 LE/ /Bluetooth v4.1 LE//Bluetooth v4.2 LE
IMEI Code	Conducted: N/A Radiation: 358410080035602/358410080035610 Conduction: 358410080036725/358410080036733
HW Version	QL1526_MB_PCB_v2.0
SW Version	NMF26F.WW_Phone-14.2016.1705.135
EUT Stage	Identical Prototype

Remark: The above EUT's information was declared by manufacturer. Please refer to the specifications or user's manual for more detailed description.



### 1.4 Product Specification of Equipment Under Test

Standards-related Product Specification	
<b>Tx/Rx Channel Frequency Range</b>	2412 MHz ~ 2462 MHz
<b>Maximum (Peak) Output Power to antenna</b>	802.11b : 19.85 dBm (0.0966 W) 802.11g : 22.25 dBm (0.1679 W) 802.11n HT20 : 22.14 dBm (0.1637 W) 802.11n HT40 : 21.92 dBm (0.1556 W)
<b>99% Occupied Bandwidth</b>	802.11b : 14.49MHz 802.11g : 19.13MHz 802.11n HT20 : 19.78MHz 802.11n HT40 : 37.26MHz
<b>Antenna Type / Gain</b>	PIFA Antenna with gain 1.38 dBi
<b>Type of Modulation</b>	802.11b : DSSS (DBPSK / DQPSK / CCK) 802.11g/n : OFDM (BPSK / QPSK / 16QAM / 64QAM)

### 1.5 Modification of EUT

No modifications are made to the EUT during all test items.



### 1.6 Testing Location

Sporton Lab is accredited to ISO 17025 by National Voluntary Laboratory Accreditation Program (NVLAP code: 600156-0) and the FCC designation No are CN5018 and CN5019.

<b>Test Site</b>	Sporton International (Shenzhen) Inc.		
<b>Test Site Location</b>	1/F, 2/F, Bldg 5, Shiling Industrial Zone, Xinwei Village, Xili, Nanshan Shenzhen City Guangdong Province 518055 China TEL: +86-755-8637-9589 FAX: +86-755-8637-9595		
<b>Test Site No.</b>	<b>Sporton Site No.</b>		<b>FCC Test Firm Registration No.</b>
	TH01-SZ	CO01-SZ	251365

<b>Test Site</b>	Sporton International (Shenzhen) Inc.		
<b>Test Site Location</b>	No. 3 Bldg the third floor of south, Shahe River west, Fengzeyuan Warehouse, Nanshan District Shenzhen City Guangdong Province 518055 China TEL: +86-755-3320-2398		
<b>Test Site No.</b>	<b>Sporton Site No.</b>		<b>FCC Test Firm Registration No.</b>
	03CH03-SZ		577730

**Note:** The test site complies with ANSI C63.4 2014 requirement.



## 1.7 Applicable Standards

According to the specifications of the manufacturer, the EUT must comply with the requirements of the following standards:

- ♦ FCC Part 15 Subpart C §15.247
- ♦ FCC KDB Publication No. 558074 D01 DTS Meas. Guidance v04
- ♦ ANSI C63.10-2013
- ♦ IC RSS-247 Issue 2
- ♦ IC RSS-Gen Issue 4

**Remark:**

1. All test items were verified and recorded according to the standards and without any deviation during the test.
2. This EUT has also been tested and complied with the requirements of FCC Part 15, Subpart B, recorded in a separate test report.





## 2 Test Configuration of Equipment Under Test

The EUT has been associated with peripherals and configuration operated in a manner tended to maximize its emission characteristics in a typical application. Frequency range investigated: conducted emission (150 kHz to 30 MHz) and radiated emission (9 kHz to the 10th harmonic of the highest fundamental frequency or to 40 GHz, whichever is lower). For radiated measurement, pre-scanned in three orthogonal panels, X, Y, Z. The worst cases (Z plane) were recorded in this report.

### 2.1 Carrier Frequency and Channel

Frequency Band	Channel	Freq. (MHz)	Channel	Freq. (MHz)
2400-2483.5 MHz	1	2412	7	2442
	2	2417	8	2447
	3	2422	9	2452
	4	2427	10	2457
	5	2432	11	2462
	6	2437	-	-



## 2.2 Test Mode

Final test mode of conducted test items and radiated spurious emissions are considering the modulation and worse data rates as below table.

Modulation	Data Rate
802.11b	1 Mbps
802.11g	6 Mbps
802.11n HT20	MCS0
802.11n HT40	MCS0

Test Cases	
<b>AC Conducted Emission</b>	<p>Mode 1 : GSM850 Idle + Bluetooth Link + WLAN Link(2.4GHz) + Earphone1 + USB Cable1 (Charging from Adapter1)</p> <p>Mode 2 : GSM850 Idle + Bluetooth Link + WLAN Link(2.4GHz) + Earphone2 + USB Cable2 (Charging from Adapter2)</p> <p>Mode 3 : GSM850 Idle + Bluetooth Link + WLAN Link(2.4GHz) + Earphone1 + USB Cable1 (Charging from Adapter3)</p>
<p><b>Remark:</b></p> <ol style="list-style-type: none"> <li>The worst case of conducted emission is mode 3; only the test data of it was reported.</li> <li>For Radiated Test Cases, The tests were performance with Adapter 1, Earphone 1, and USB Cable 1.</li> </ol>	

## 2.3 Connection Diagram of Test System

<WLAN Tx Mode>

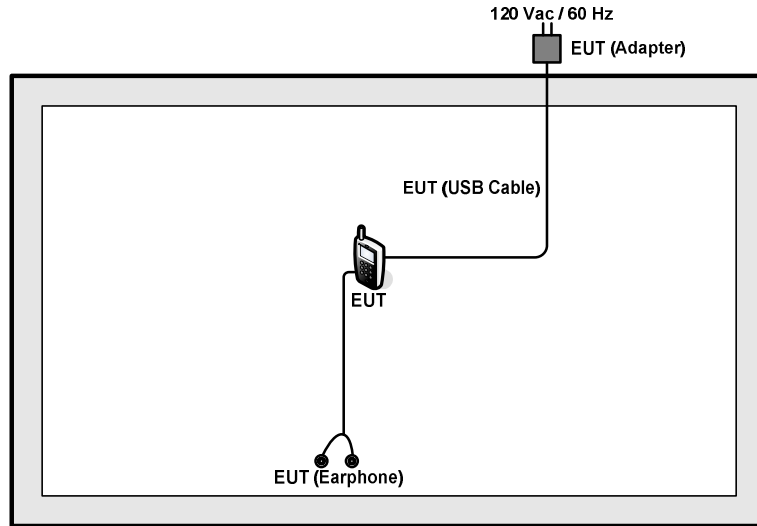

<AC Conducted Emission Mode>

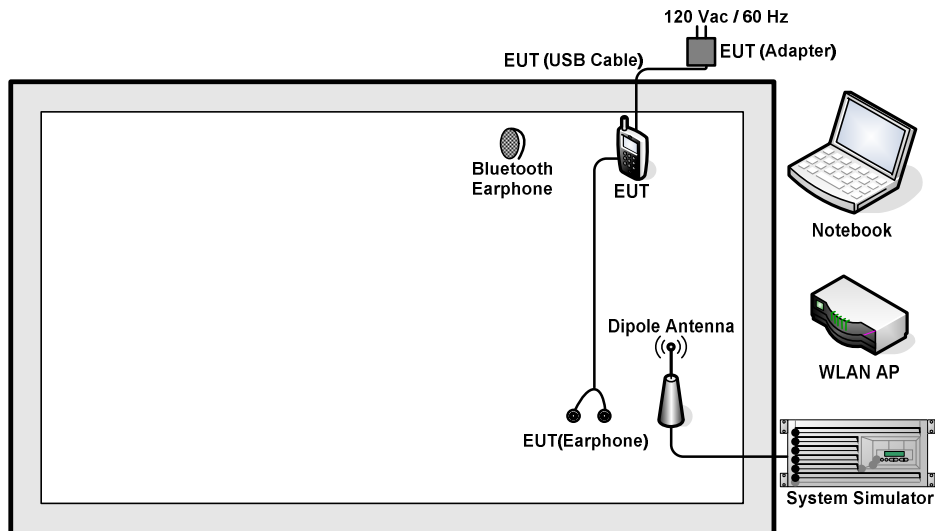



## 2.4 Support Unit used in test configuration and system

Item	Equipment	Trade Name	Model Name	FCC ID	Data Cable	Power Cord
1.	System Simulator	Anritsu	MT8820C	N/A	N/A	Unshielded, 1.8 m
2.	WLAN AP	D-Link	DIR-865L	KA2IR865LA1	N/A	Unshielded, 1.8 m
3.	Notebook	Lenovo	E450	FCC DoC	N/A	Shielded cable DC O/P 1.8 m Unshielded AC I/P cable 1.2 m
4.	Bluetooth Earphone	Nokia	BH-108	N/A	N/A	N/A
5.	SD Card	N/A	MicroSD HC	FCC DoC	N/A	N/A

## 2.5 EUT Operation Test Setup

For WLAN function, the engineering test program was provided and enabled to make EUT (connect with Bluetooth base station to) continuous transmit/receive.

For AC power line conducted emissions, the EUT was set to connect with the WLAN AP under large package sizes transmission.



## 2.6 Measurement Results Explanation Example

For all conducted test items:

The offset level is set in the spectrum analyzer to compensate the RF cable loss and attenuator factor between EUT conducted output port and spectrum analyzer. With the offset compensation, the spectrum analyzer reading level is exactly the EUT RF output level.

Example :

The spectrum analyzer offset is derived from RF cable loss and attenuator factor.

*Offset = RF cable loss + attenuator factor.*

Following shows an offset computation example with cable loss 5.0 dB and 10dB attenuator.

$$\begin{aligned} \text{Offset(dB)} &= \text{RF cable loss(dB)} + \text{attenuator factor(dB)}. \\ &= 5.0 + 10 = 15.0 \text{ (dB)} \end{aligned}$$

### 3 Test Result

#### 3.1 6dB and 99% Bandwidth Measurement

##### 3.1.1 Limit of 6dB and 99% Bandwidth

The minimum 6 dB bandwidth shall be at least 500 kHz.

##### 3.1.2 Measuring Instruments

The measuring equipment is listed in the section 4 of this test report.

##### 3.1.3 Test Procedures

1. The testing follows FCC KDB Publication No. 558074 DTS D01 Meas. Guidance v04.
2. The RF output of EUT was connected to the spectrum analyzer by RF cable and attenuator. The path loss was compensated to the results for each measurement.
3. Set to the maximum power setting and enable the EUT transmit continuously.
4. Make the measurement with the spectrum analyzer's resolution bandwidth (RBW) = 100 kHz. Set the Video bandwidth (VBW) = 300 kHz. In order to make an accurate measurement. The 6 dB bandwidth must be greater than 500 kHz.
5. For 99% Bandwidth Measurement, the spectrum analyzer's resolution bandwidth (RBW) = 1MHz and set the Video bandwidth (VBW) = 3MHz.
6. Measure and record the results in the test report.

##### 3.1.4 Test Setup

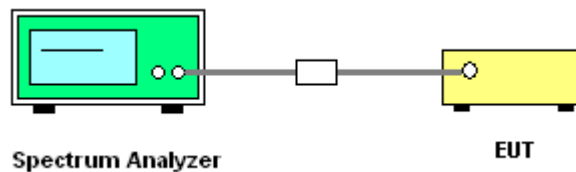



### 3.1.5 Test Result of 6dB and 99% Occupied Bandwidth

Please refer to Appendix A.

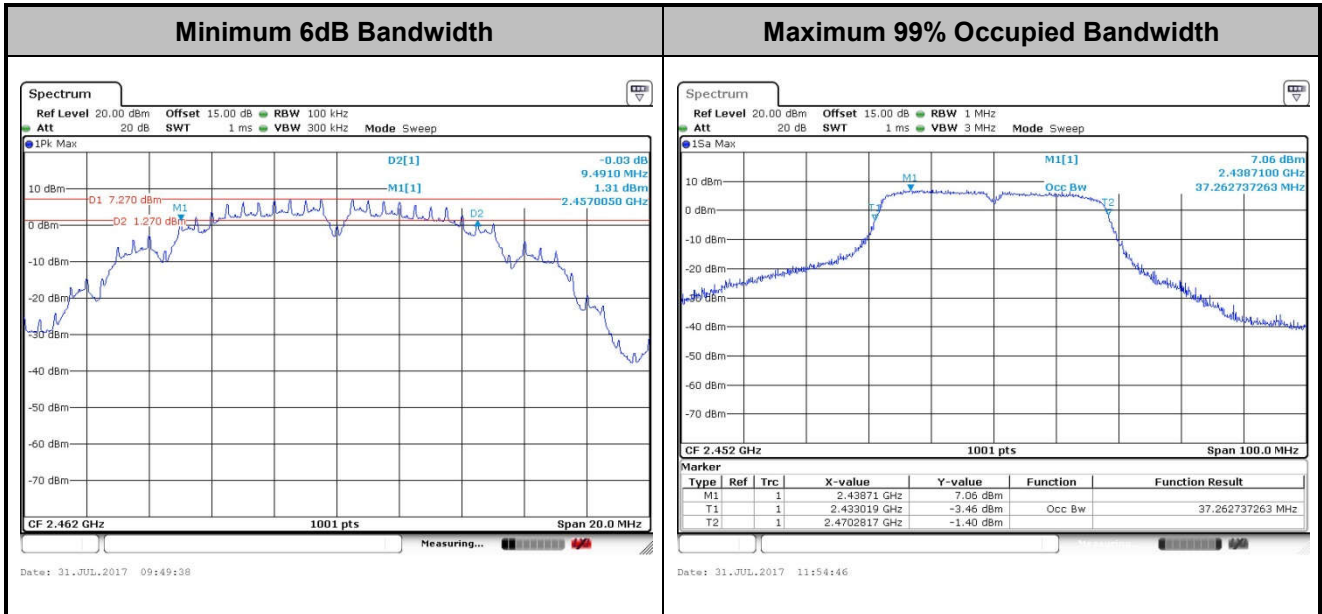

Note : The occupied channel bandwidth is maintained within the band of operation for all of the modulations.

## 3.2 Output Power Measurement

### 3.2.1 Limit of Output Power

For systems using digital modulation in the 2400-2483.5MHz, the limit for peak output power is 30dBm. If transmitting antenna of directional gain greater than 6dBi are used the peak output power from the intentional radiator shall be reduced below the above stated value by the amount in dB that the directional gain of the antenna exceeds 6 dBi. In case of point-to-point operation, the limit has to be reduced by 1dB for every 3dB that the directional gain of the antenna exceeds 6dBi.

### 3.2.2 Measuring Instruments

The measuring equipment is listed in the section 4 of this test report.

### 3.2.3 Test Procedures

1. The testing follows the Measurement Procedure of FCC KDB No. 558074 DTS D01 Meas. Guidance v04 section 9.1.2 PKPM1 Peak power meter method.
2. The RF output of EUT was connected to the power meter by RF cable and attenuator. The path loss was compensated to the results for each measurement.
3. Set to the maximum power setting and enable the EUT transmit continuously.
4. Measure the conducted output power and record the results in the test report.

### 3.2.4 Test Setup

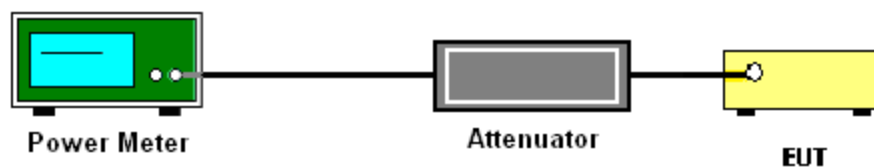

### 3.2.5 Test Result of Peak Output Power

Please refer to Appendix A.

### 3.2.6 Test Result of Average output Power (Reporting Only)

Please refer to Appendix A.



### 3.3 Power Spectral Density Measurement

#### 3.3.1 Limit of Power Spectral Density

The peak power spectral density shall not be greater than 8dBm in any 3kHz band at any time interval of continuous transmission.

#### 3.3.2 Measuring Instruments

The measuring equipment is listed in the section 4 of this test report.

#### 3.3.3 Test Procedures

1. The testing follows Measurement Procedure 10.2 Method PKPSD of FCC KDB Publication No. 558074 D01 DTS Meas. Guidance v04
2. The RF output of EUT was connected to the spectrum analyzer by RF cable and attenuator. The path loss was compensated to the results for each measurement.
3. Set to the maximum power setting and enable the EUT transmit continuously.
4. Make the measurement with the spectrum analyzer's resolution bandwidth (RBW) = 3 kHz. Video bandwidth VBW = 10 kHz In order to make an accurate measurement, set the span to 1.5 times DTS Channel Bandwidth. (6dB BW)
5. Detector = peak, Sweep time = auto couple, Trace mode = max hold, Allow trace to fully stabilize. Use the peak marker function to determine the maximum power level.
6. Measure and record the results in the test report.

#### 3.3.4 Test Setup

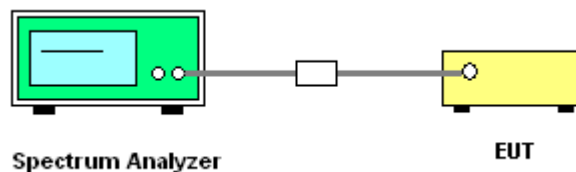



### 3.3.5 Test Result of Power Spectral Density

Please refer to Appendix A.

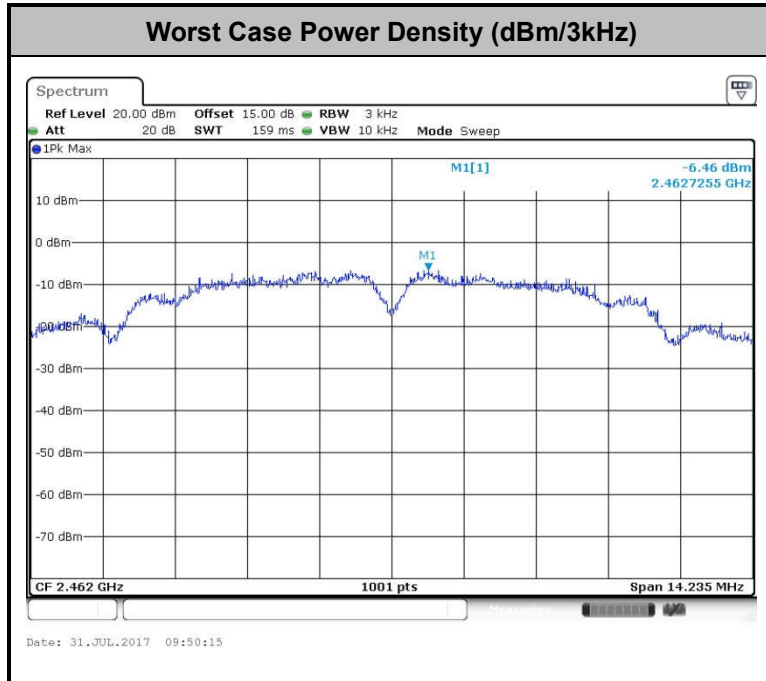

## 3.4 Conducted Band Edges and Spurious Emission Measurement

### 3.4.1 Limit of Conducted Band Edges and Spurious Emission Measurement

In any 100 kHz bandwidth outside of the authorized frequency band, the emissions which fall in the non-restricted bands shall be attenuated at least 20 dB / 30dB relative to the maximum PSD level in 100 kHz by RF conducted measurement.

### 3.4.2 Measuring Instruments

The measuring equipment is listed in the section 4 of this test report.

### 3.4.3 Test Procedures

1. The testing follows FCC KDB Publication No. 558074 D01 DTS Meas. Guidance v04.
2. The RF output of EUT was connected to the spectrum analyzer by RF cable and attenuator. The path loss was compensated to the results for each measurement.
3. Set to the maximum power setting and enable the EUT transmit continuously.
4. Set RBW = 100 kHz, VBW=300 kHz, Peak Detector. Unwanted Emissions measured in any 100 kHz bandwidth outside of the authorized frequency band shall be attenuated by at least 20 dB relative to the maximum in-band peak PSD level in 100 kHz when maximum peak conducted output power procedure is used. If the transmitter complies with the conducted power limits based on the use of RMS averaging over a time interval, the attenuation required under this paragraph shall be 30 dB instead of 20 dB.
5. Measure and record the results in the test report.
6. The RF fundamental frequency should be excluded against the limit line in the operating frequency band.

### 3.4.4 Test Setup

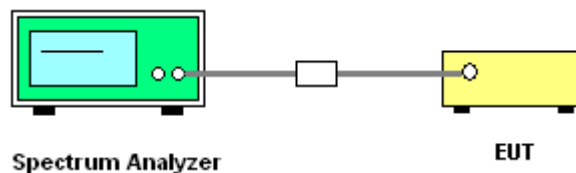



### 3.4.5 Test Result of Conducted Band Edges and Spurious Emission

Test Mode :	802.11b	Temperature :	24~26°C
Test Band :	2.4GHz Low	Relative Humidity :	50~53%
Test Channel :	01	Test Engineer :	Sam Zheng

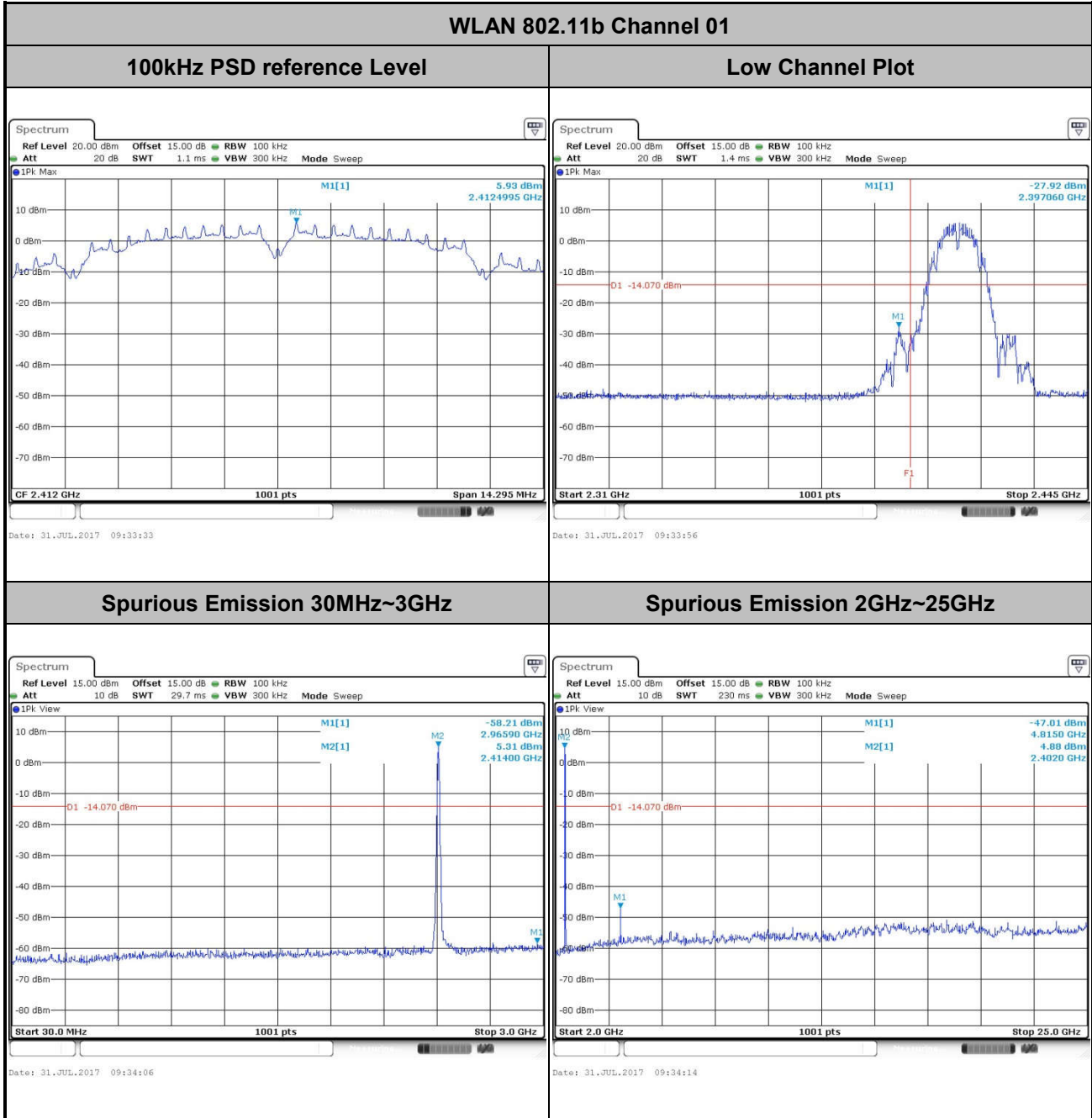



Test Mode :	802.11b	Temperature :	24~26°C
Test Band :	2.4GHz Mid	Relative Humidity :	50~53%
Test Channel :	06	Test Engineer :	Sam Zheng

WLAN 802.11b Channel 06

100kHz PSD reference Level

Mid Channel Plot

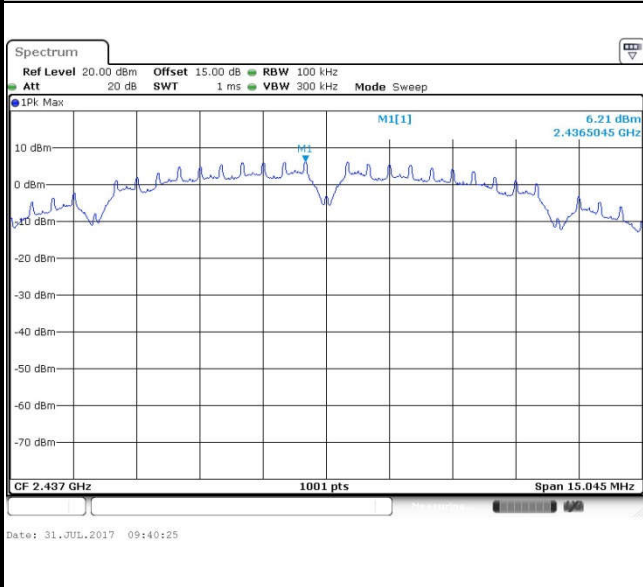

Spurious Emission 30MHz~3GHz

Spurious Emission 2GHz~25GHz

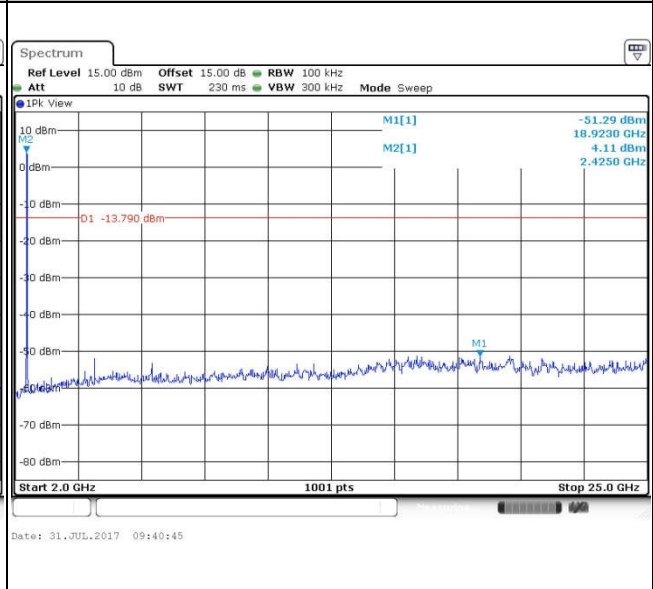
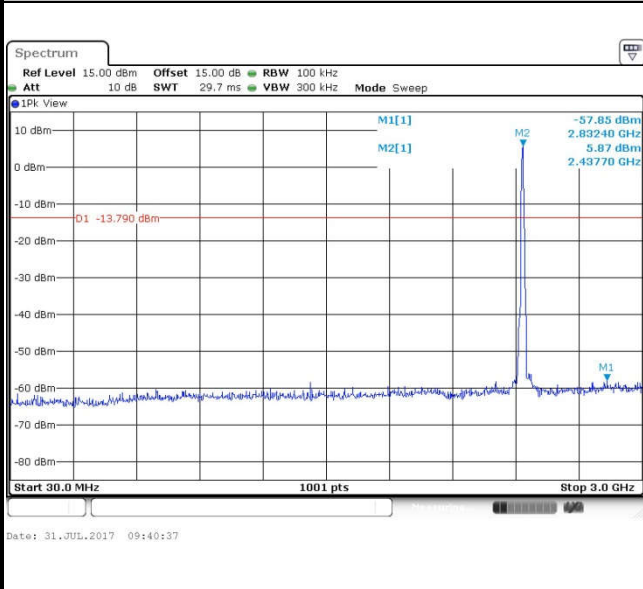



Test Mode :	802.11b	Temperature :	24~26°C
Test Band :	2.4GHz High	Relative Humidity :	50~53%
Test Channel :	11	Test Engineer :	Sam Zheng

WLAN 802.11b Channel 11

100kHz PSD reference Level

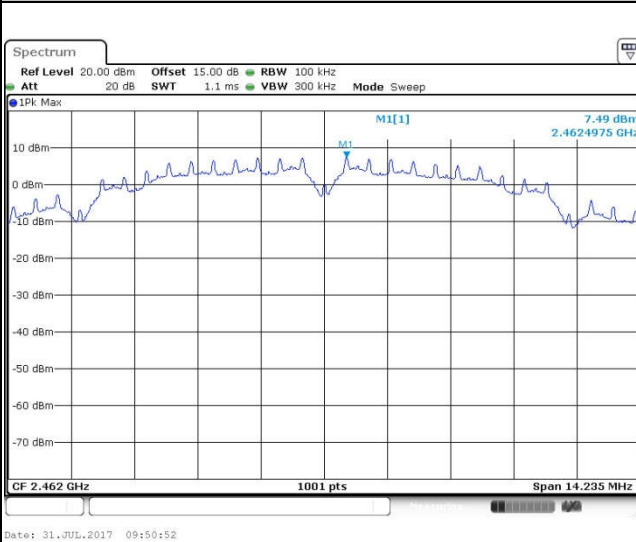

High Channel Plot

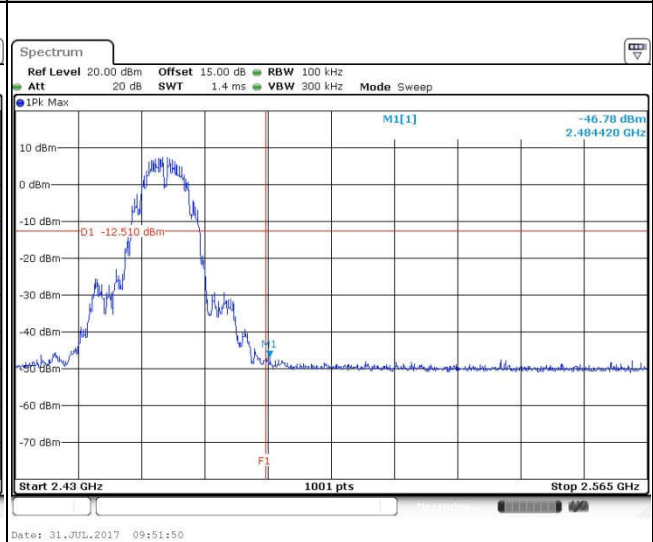

Spurious Emission 30MHz~3GHz

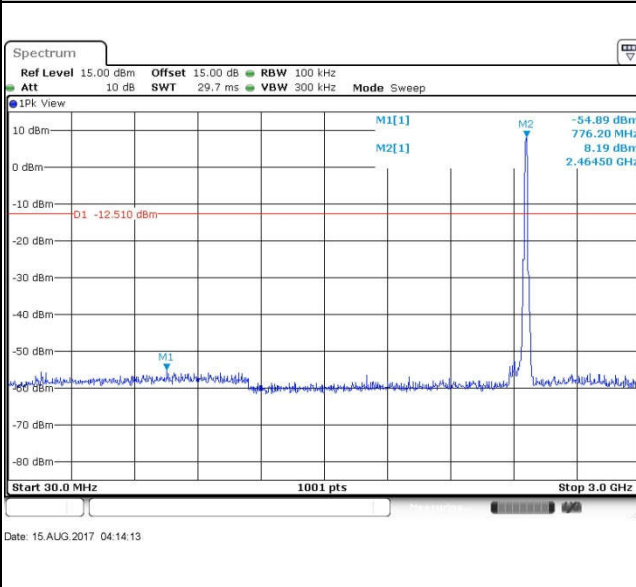

Spurious Emission 2GHz~25GHz

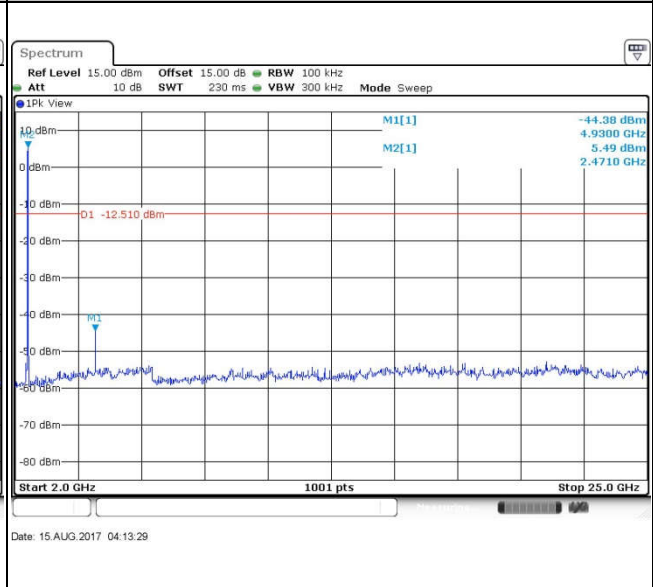



Test Mode :	802.11g	Temperature :	24~26°C
Test Band :	2.4GHz Low	Relative Humidity :	50~53%
Test Channel :	01	Test Engineer :	Sam Zheng

WLAN 802.11g Channel 01

100kHz PSD reference Level

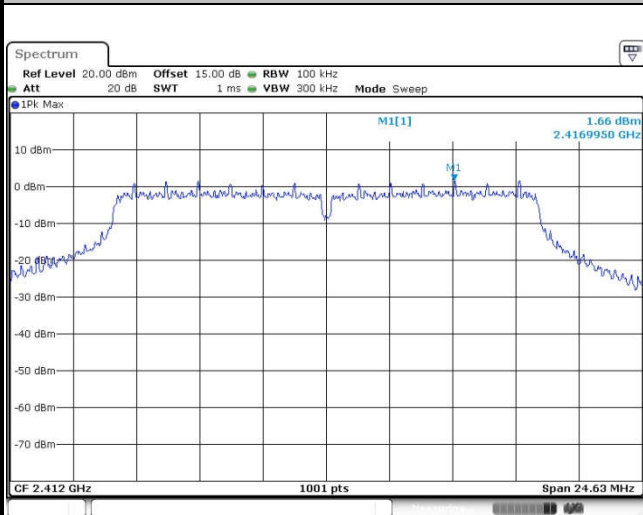

Date: 31.JUL.2017 10:01:31

Low Channel Plot

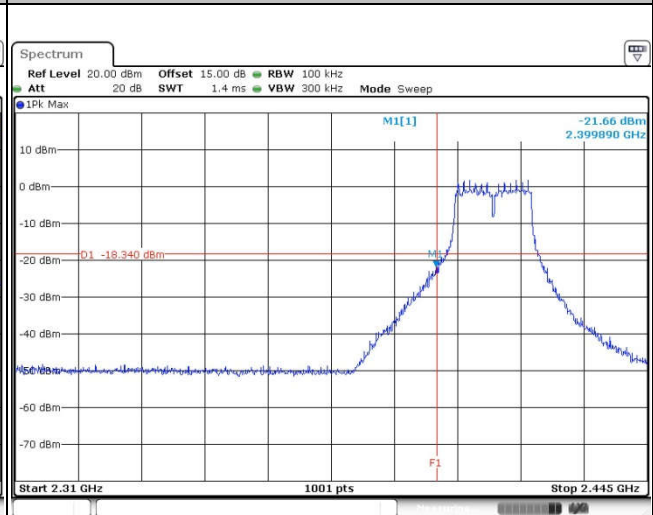

Date: 31.JUL.2017 10:02:01

Spurious Emission 30MHz~3GHz

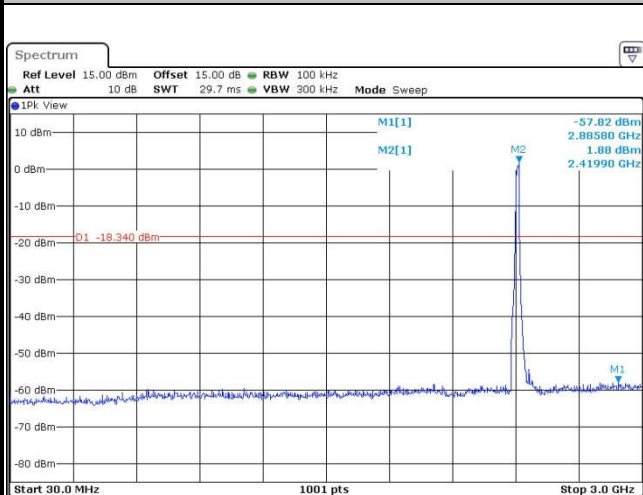

Date: 31.JUL.2017 10:08:24

Spurious Emission 2GHz~25GHz

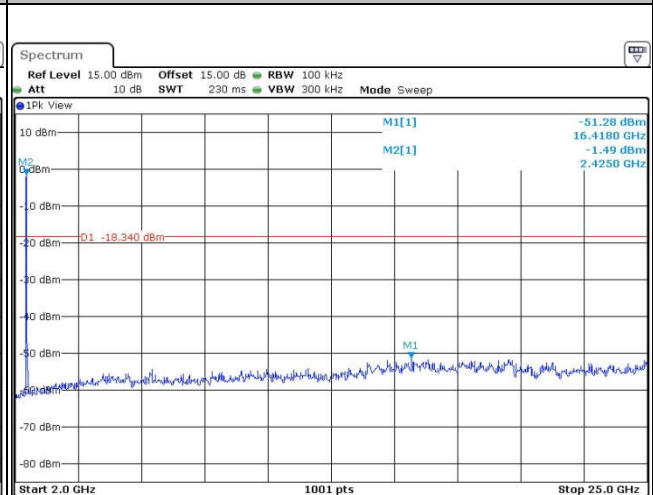

Date: 31.JUL.2017 10:06:51



Test Mode :	802.11g	Temperature :	24~26°C
Test Band :	2.4GHz Mid	Relative Humidity :	50~53%
Test Channel :	06	Test Engineer :	Sam Zheng

WLAN 802.11g Channel 06

100kHz PSD reference Level

Mid Channel Plot

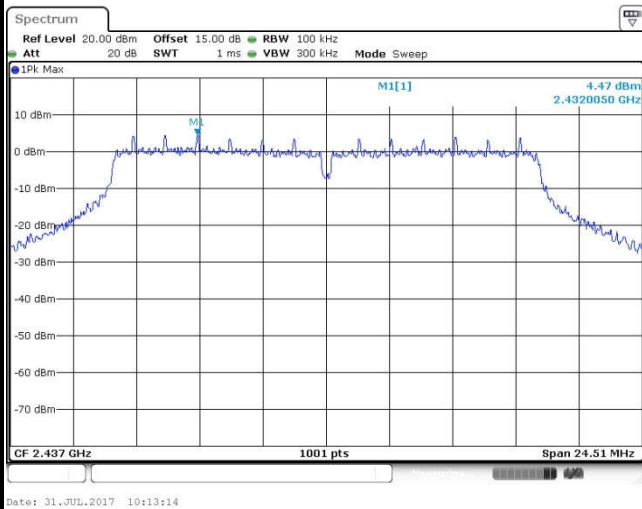

Spurious Emission 30MHz~3GHz

Spurious Emission 2GHz~25GHz

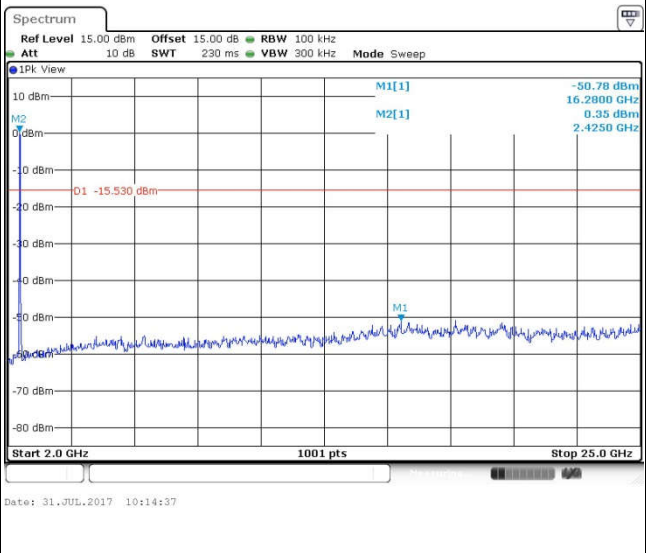
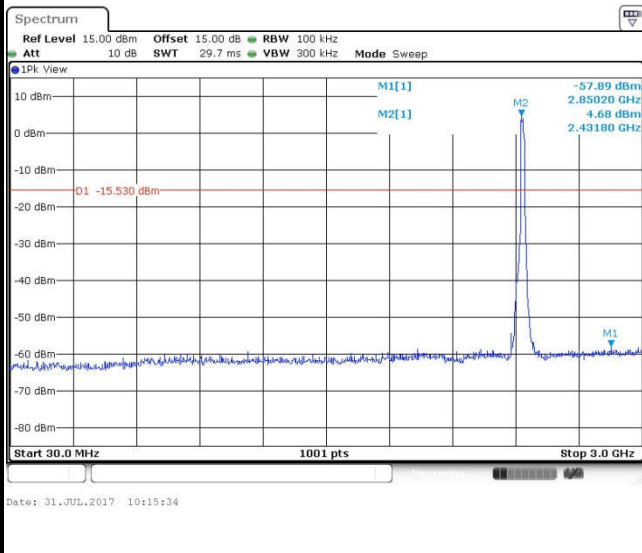





Test Mode :	802.11g	Temperature :	24~26°C
Test Band :	2.4GHz High	Relative Humidity :	50~53%
Test Channel :	11	Test Engineer :	Sam Zheng

WLAN 802.11g Channel 11

100kHz PSD reference Level

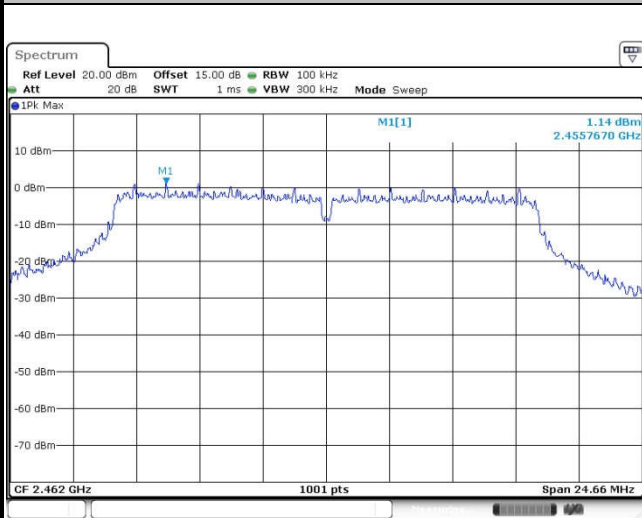

Date: 31.JUL.2017 10:20:24

High Channel Plot

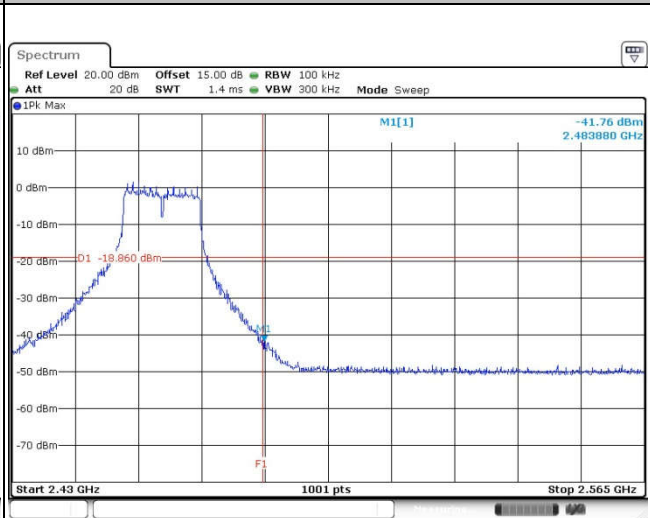

Date: 31.JUL.2017 10:21:29

Spurious Emission 30MHz~3GHz

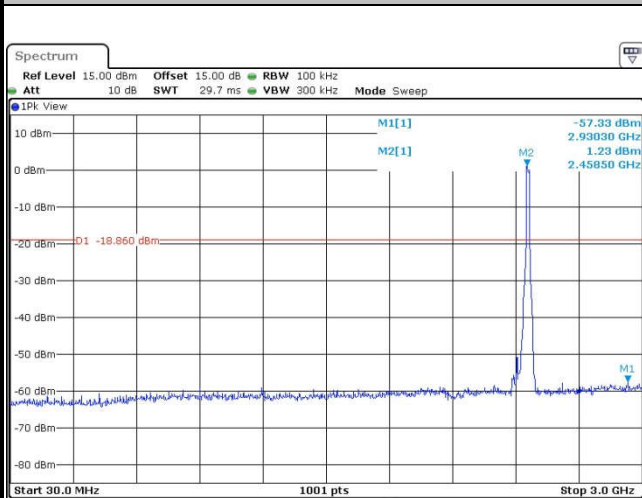

Date: 31.JUL.2017 10:23:55

Spurious Emission 2GHz~25GHz

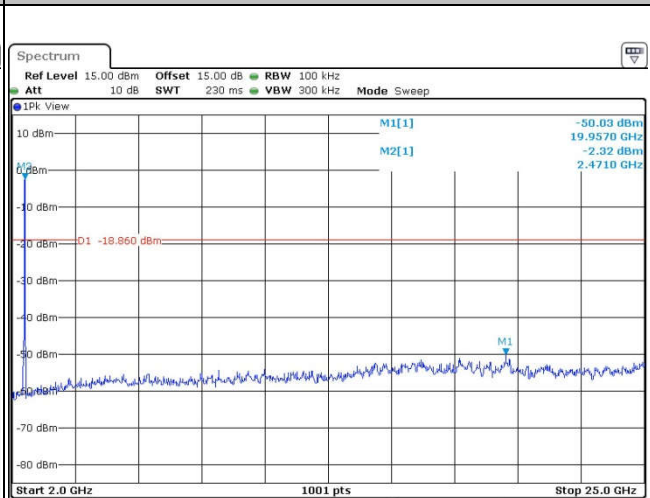

Date: 31.JUL.2017 10:22:25



Test Mode :	802.11n HT20	Temperature :	24~26°C
Test Band :	2.4GHz Low	Relative Humidity :	50~53%
Test Channel :	01	Test Engineer :	Sam Zheng

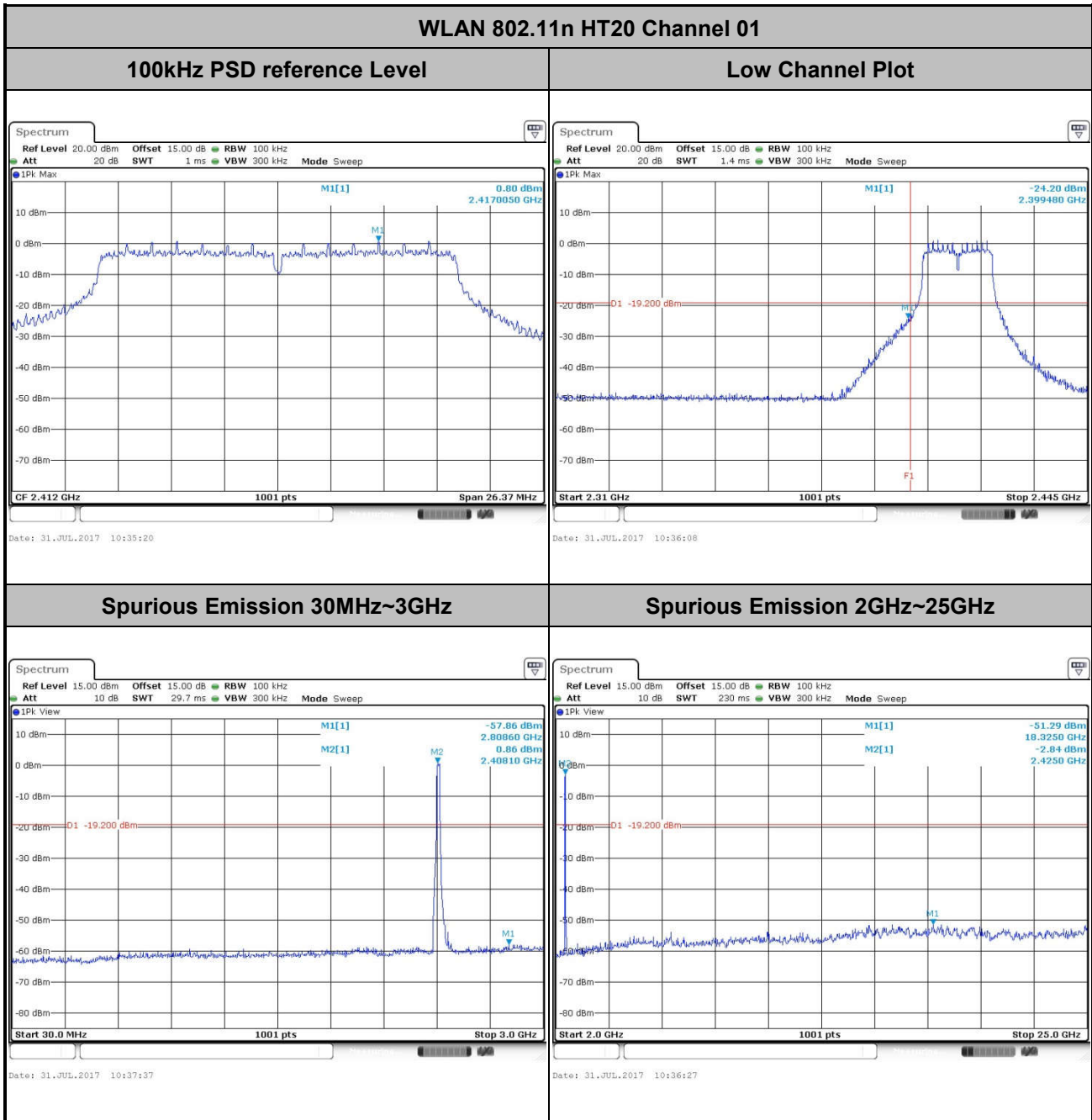



Test Mode :	802.11n HT20	Temperature :	24~26°C
Test Band :	2.4GHz Mid	Relative Humidity :	50~53%
Test Channel :	06	Test Engineer :	Sam Zheng

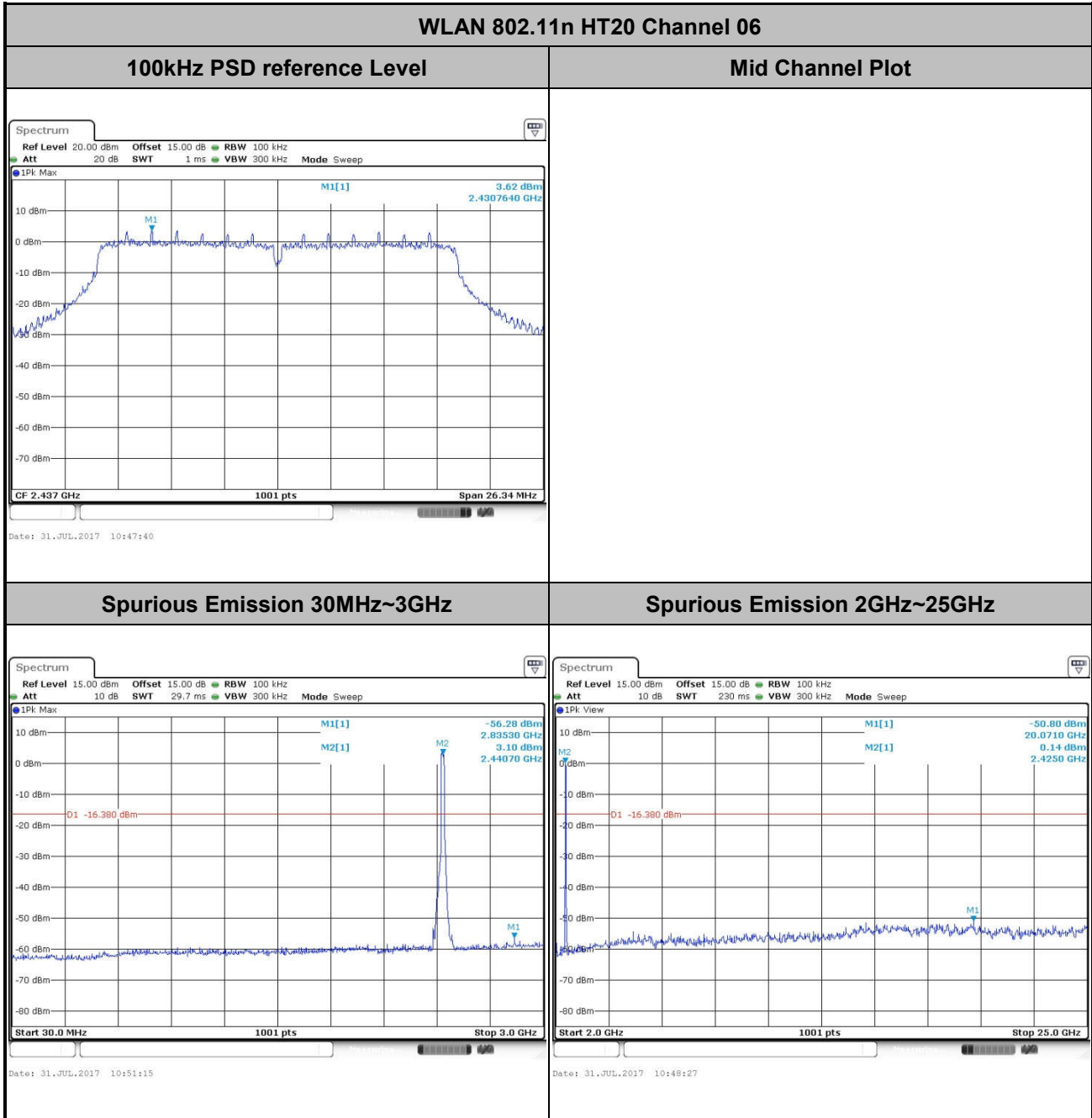



Test Mode :	802.11n HT20	Temperature :	24~26°C
Test Band :	2.4GHz High	Relative Humidity :	50~53%
Test Channel :	11	Test Engineer :	Sam Zheng

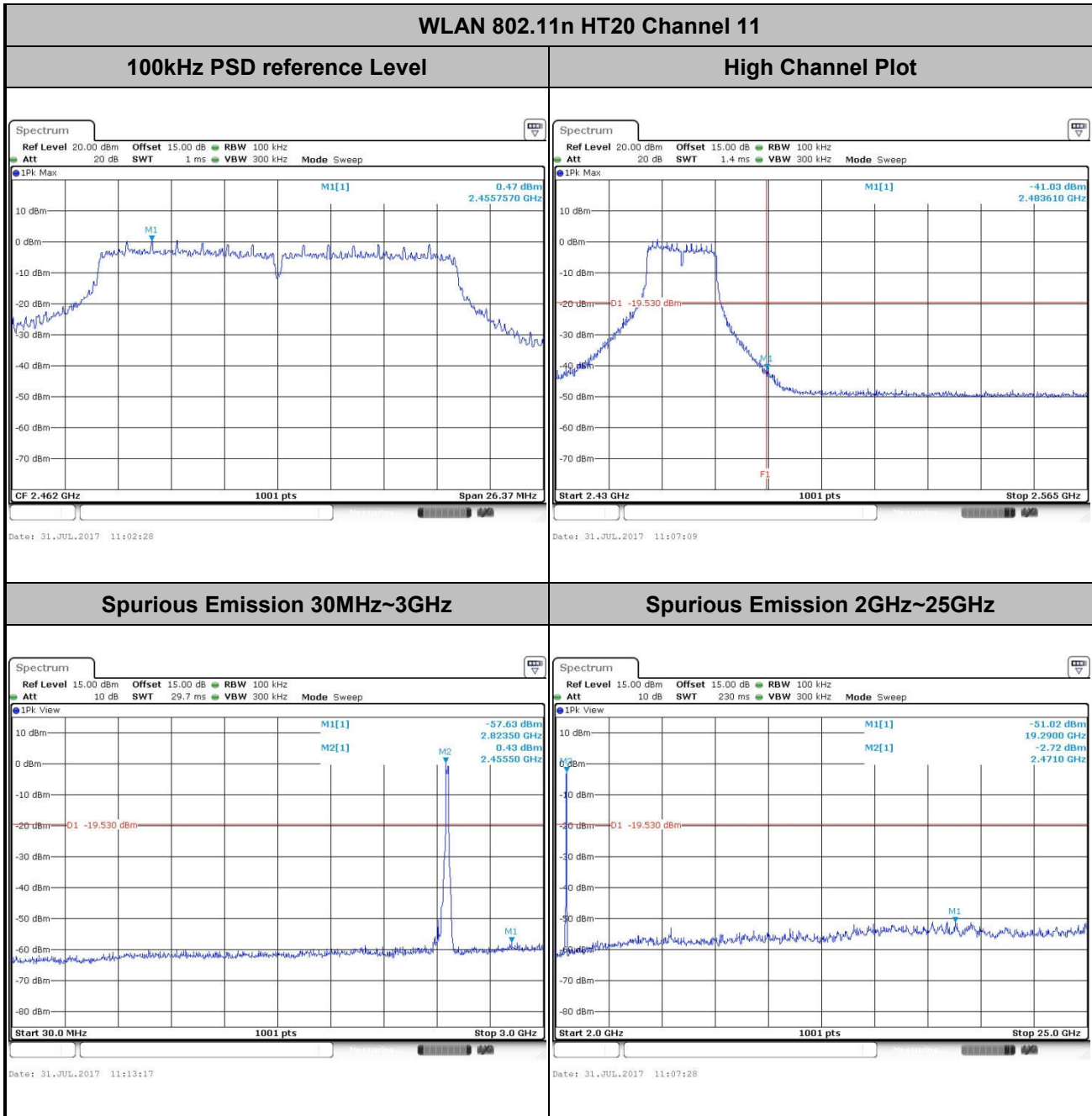



Test Mode :	802.11n HT40	Temperature :	24~26°C
Test Band :	2.4GHz Low	Relative Humidity :	50~53%
Test Channel :	03	Test Engineer :	Sam Zheng

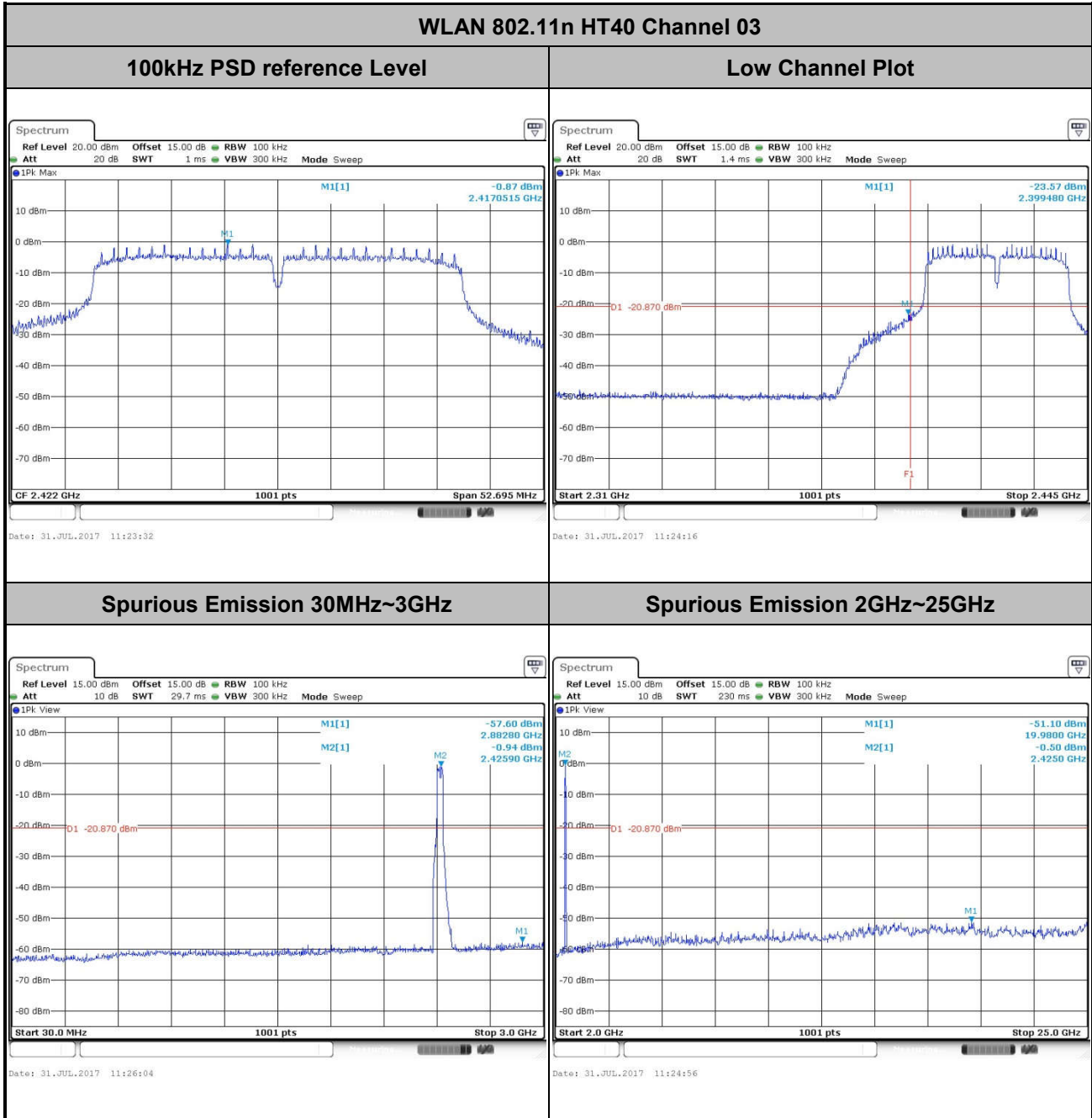



Test Mode :	802.11n HT40	Temperature :	24~26°C
Test Band :	2.4GHz Mid	Relative Humidity :	50~53%
Test Channel :	06	Test Engineer :	Sam Zheng

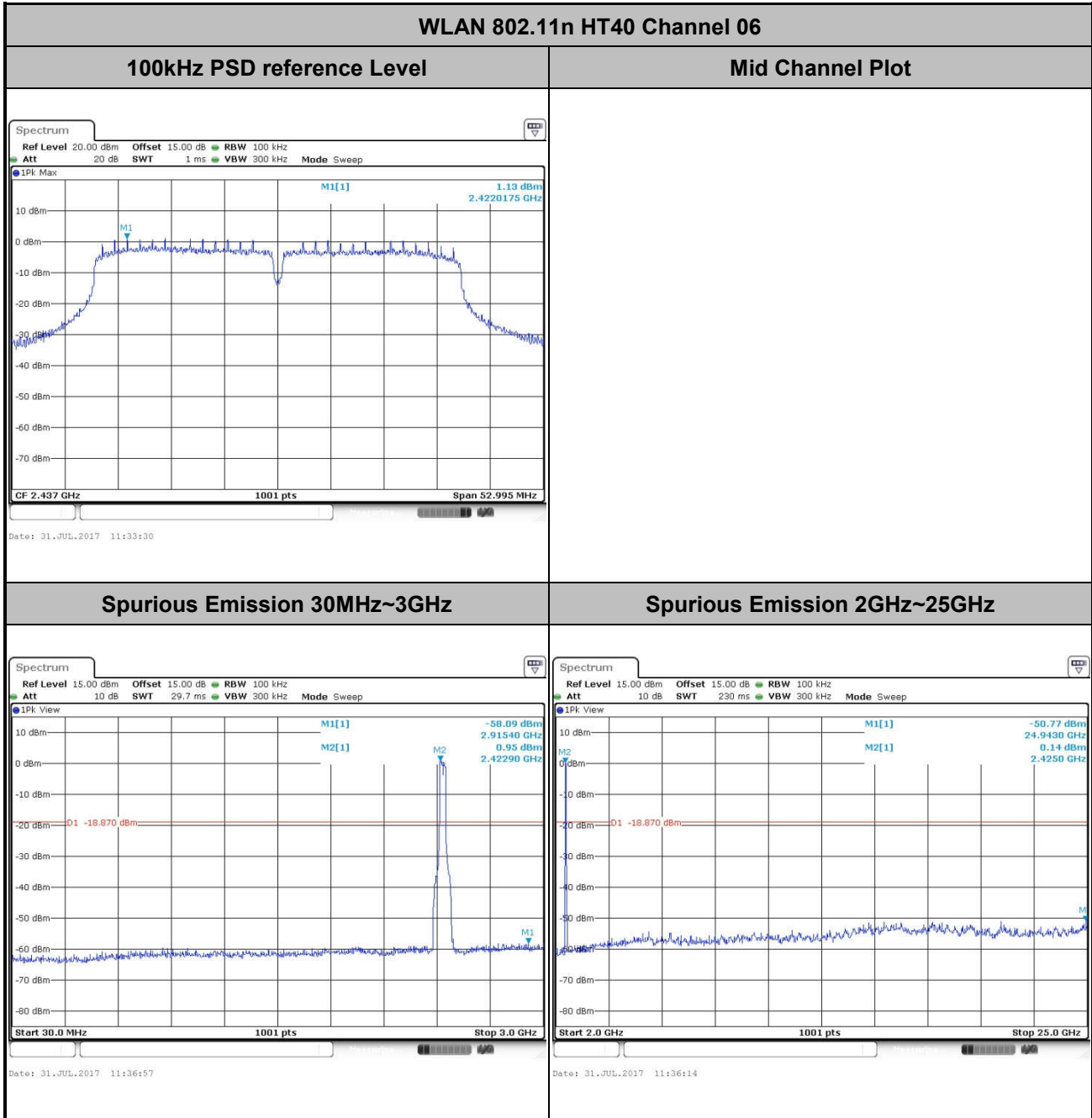



Test Mode :	802.11n HT40	Temperature :	24~26°C
Test Band :	2.4GHz High	Relative Humidity :	50~53%
Test Channel :	09	Test Engineer :	Sam Zheng

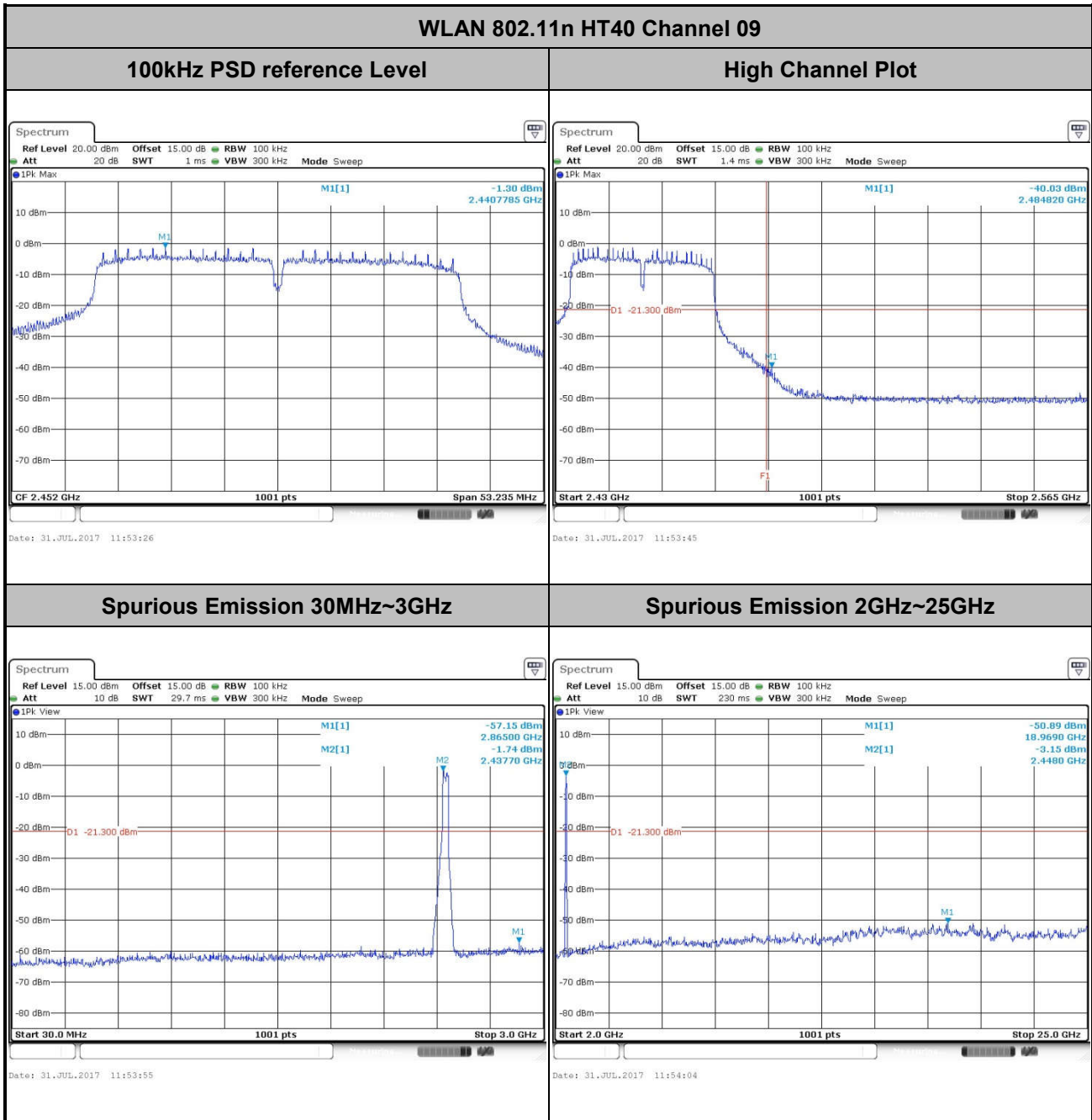



### 3.5 Radiated Band Edges and Spurious Emission Measurement

#### 3.5.1 Limit of Radiated band edge and Spurious Emission Measurement

In any 100 kHz bandwidth outside the intentional radiator frequency band, all harmonics/spurious must be at least 20 dB below the highest emission level within the authorized band. If the output power of this device was measured by spectrum analyzer, the attenuation under this paragraph shall be 30 dB instead of 20 dB. In addition, radiated emissions which fall in the restricted bands must also comply with the limits as below.

Frequency (MHz)	Field Strength (microvolts/meter)	Measurement Distance (meters)
0.009 – 0.490	2400/F(kHz)	300
0.490 – 1.705	24000/F(kHz)	30
1.705 – 30.0	30	30
30 – 88	100	3
88 – 216	150	3
216 - 960	200	3
Above 960	500	3

#### 3.5.2 Measuring Instruments

The measuring equipment is listed in the section 4 of this test report.





### **3.5.3 Test Procedures**

1. The testing follows FCC KDB Publication No. 558074 D01 DTS Meas. Guidance v04.
2. The EUT was arranged to its worst case and then tune the antenna tower (from 1 m to 4 m) and turntable (from 0 degree to 360 degrees) to find the maximum reading. A pre-amp and a high pass filter are used for the test in order to get better signal level.
3. The EUT was placed on a turntable with 0.8 meter for frequency below 1GHz and 1.5 meter for frequency above 1GHz respectively above ground.
4. The EUT was set 3 meters from the interference receiving antenna, which was mounted on the top of a variable height antenna tower.
5. Corrected Reading: Antenna Factor + Cable Loss + Read Level - Preamp Factor = Level
6. For measurement below 1GHz, If the emission level of the EUT measured by the peak detector is 3 dB lower than the applicable limit, the peak emission level will be reported. Otherwise, the emission measurement will be repeated using the quasi-peak detector and reported.
7. Use the following spectrum analyzer settings:
  - (1) Span shall wide enough to fully capture the emission being measured;
  - (2) Set RBW=100 kHz for  $f < 1$  GHz; VBW  $\geq$  RBW; Sweep = auto; Detector function = peak; Trace = max hold;
  - (3) Set RBW = 1 MHz, VBW= 3MHz for  $f \geq 1$  GHz for peak measurement.

For average measurement:

    - VBW = 10 Hz, when duty cycle is no less than 98 percent.
    - VBW  $\geq 1/T$ , when duty cycle is less than 98 percent where T is the minimum transmission duration over which the transmitter is on and is transmitting at its maximum power control level for the tested mode of operation.

### 3.5.4 Test Setup

For radiated emissions below 30MHz

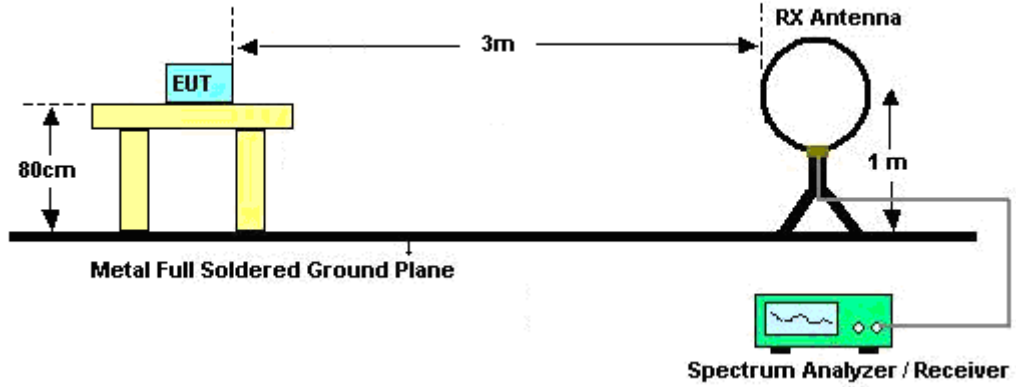

For radiated emissions from 30MHz to 1GHz

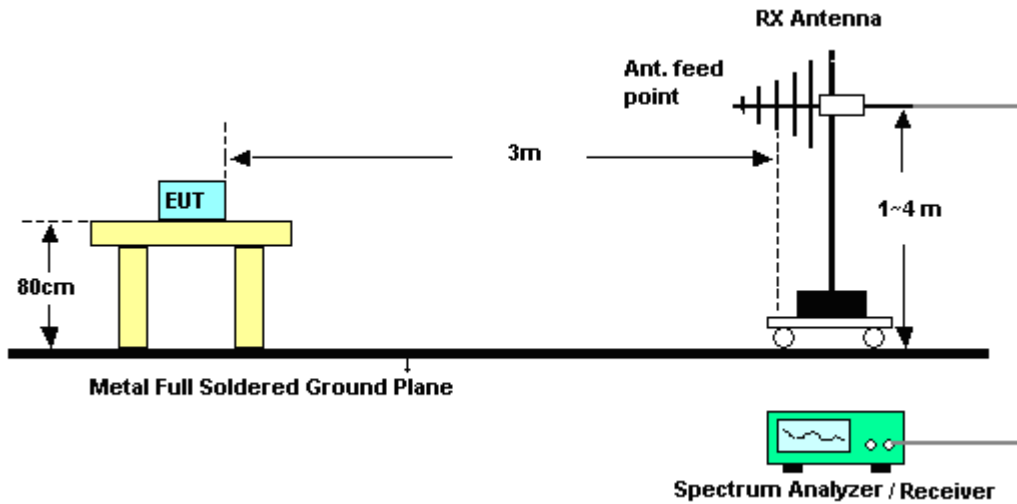

For radiated emissions above 1GHz

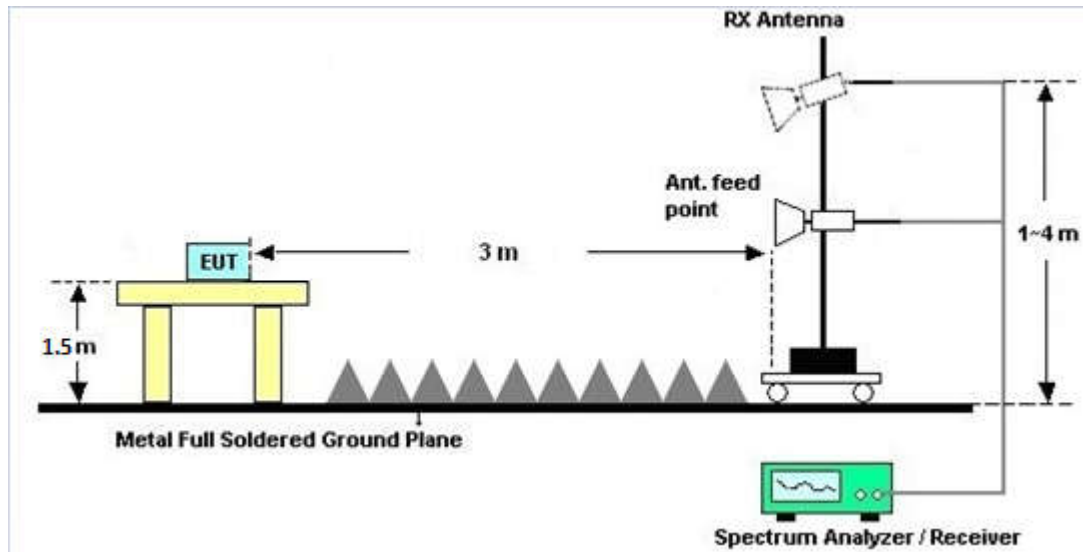

### 3.5.5 Test Results of Radiated Spurious Emissions (9kHz ~ 30MHz)

The low frequency, which started from 9 kHz to 30MHz, was pre-scanned and the result which was 20dB lower than the limit line was not reported.

### 3.5.6 Test Result of Radiated Spurious at Band Edges

Please refer to Appendix B.

### 3.5.7 Duty Cycle

Please refer to Appendix C.

### 3.5.8 Test Result of Radiated Spurious Emission (30MHz ~ 10<sup>th</sup> Harmonic)

Please refer to Appendix B.



### 3.6 AC Conducted Emission Measurement

#### 3.6.1 Limit of AC Conducted Emission

For equipment that is designed to be connected to the public utility (AC) power line, the radio frequency voltage that is conducted back onto the AC power line on any frequency or frequencies within the band 150 kHz to 30 MHz shall not exceed the limits in the following table.

Frequency of Emission (MHz)	Conducted Limit (dBµV)	
	Quasi-Peak	Average
0.15-0.5	66 to 56*	56 to 46*
0.5-5	56	46
5-30	60	50

\*Decreases with the logarithm of the frequency.

#### 3.6.2 Measuring Instruments

The measuring equipment is listed in the section 4 of this test report.

#### 3.6.3 Test Procedures

1. The EUT was placed 0.4 meter from the conducting wall of the shielding room, and it was kept at least 80 centimeters from any other grounded conducting surface.
2. Connect EUT to the power mains through a line impedance stabilization network (LISN).
3. All the support units are connecting to the other LISN.
4. The LISN provides 50 ohm coupling impedance for the measuring instrument.
5. The FCC states that a 50 ohm, 50 microhenry LISN should be used.
6. Both sides of AC line were checked for maximum conducted interference.
7. The frequency range from 150 kHz to 30 MHz was searched.
8. Set the test-receiver system to Peak Detect Function and specified bandwidth (IF bandwidth = 9kHz) with Maximum Hold Mode.

### 3.6.4 Test Setup

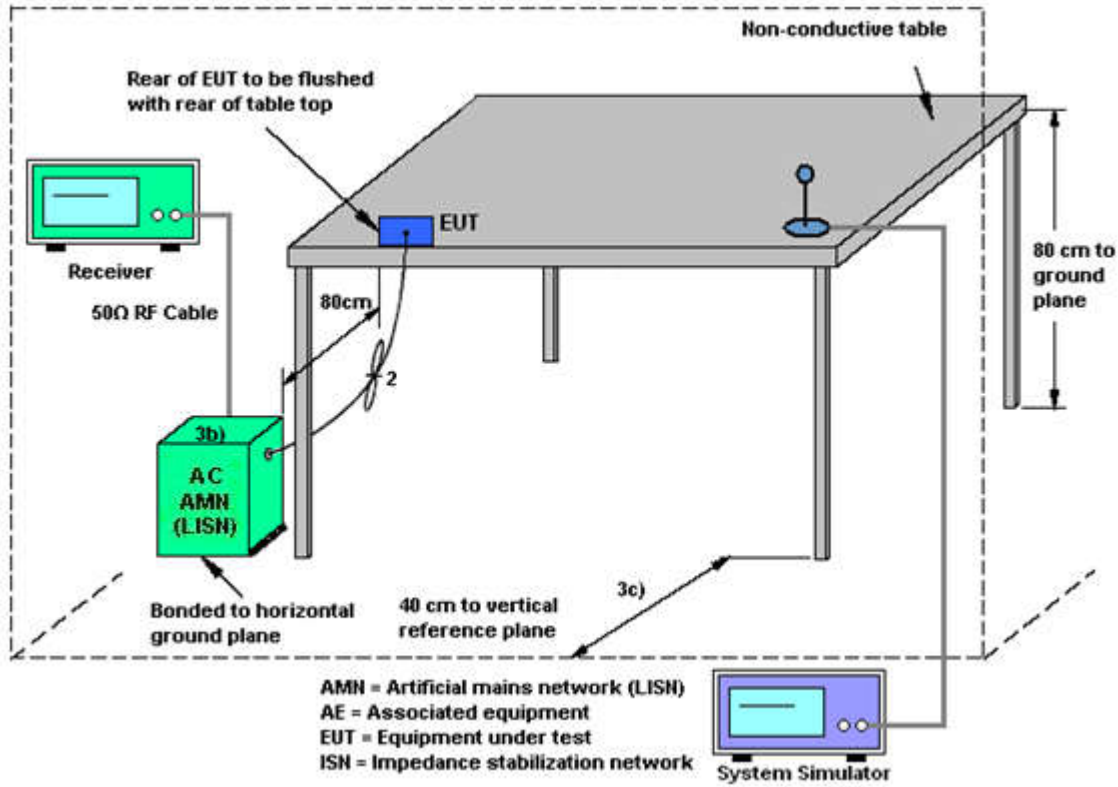



3.6.5 Test Result of AC Conducted Emission

Test Mode :	Mode 3	Temperature :	24~25°C
Test Engineer :	HaoHai YE	Relative Humidity :	50~55%
Test Voltage :	120Vac / 60Hz	Phase :	Line
Function Type :	GSM850 Idle + Bluetooth Link + WLAN Link(2.4GHz) + Earphone1 + USB Cable1 (Charging from Adapter3)		

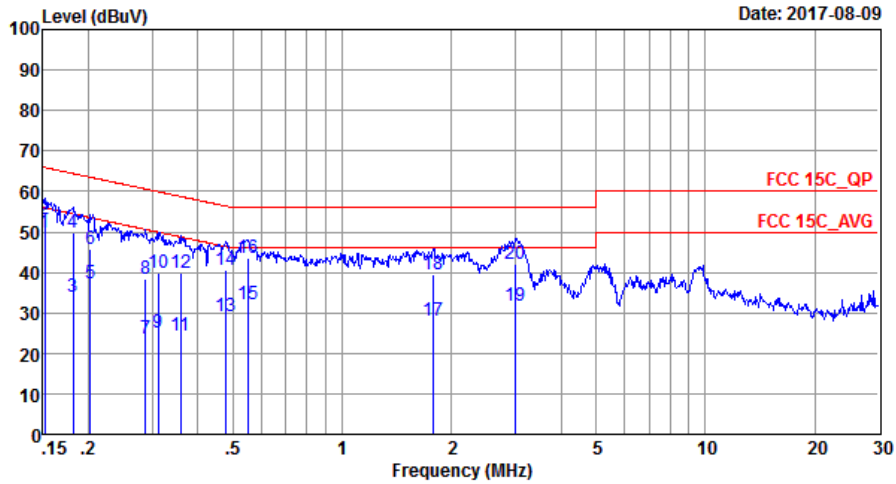

Site : C001-SZ  
 Condition: FCC 15C\_QP LISN\_20170301\_L LINE

Mode : Mode 3  
 IMEI : 358410080036725/358410080036733

	Freq	Level	Over Limit	Limit Line	Read Level	LISN Factor	Cable Loss	Remark
	MHz	dBuV	dB	dBuV	dBuV	dB	dB	
1 *	0.15	49.93	-5.98	55.91	39.50	0.03	10.40	Average
2	0.15	53.13	-12.78	65.91	42.70	0.03	10.40	QP
3	0.18	34.01	-20.41	54.42	23.70	0.03	10.28	Average
4	0.18	49.71	-14.71	64.42	39.40	0.03	10.28	QP
5	0.20	37.45	-16.04	53.49	27.20	0.03	10.22	Average
6	0.20	45.75	-17.74	63.49	35.50	0.03	10.22	QP
7	0.29	23.55	-27.04	50.59	13.30	0.03	10.22	Average
8	0.29	38.35	-22.24	60.59	28.10	0.03	10.22	QP
9	0.31	24.95	-24.98	49.93	14.70	0.03	10.22	Average
10	0.31	39.95	-19.98	59.93	29.70	0.03	10.22	QP
11	0.36	24.53	-24.21	48.74	14.30	0.03	10.20	Average
12	0.36	39.73	-19.01	58.74	29.50	0.03	10.20	QP
13	0.48	29.10	-17.31	46.41	18.90	0.02	10.18	Average
14	0.48	40.70	-15.71	56.41	30.50	0.02	10.18	QP
15	0.55	32.00	-14.00	46.00	21.80	0.02	10.18	Average
16	0.55	43.50	-12.50	56.00	33.30	0.02	10.18	QP
17	1.78	28.06	-17.94	46.00	17.80	0.10	10.16	Average
18	1.78	39.46	-16.54	56.00	29.20	0.10	10.16	QP
19	3.01	31.57	-14.43	46.00	21.20	0.16	10.21	Average
20	3.01	42.07	-13.93	56.00	31.70	0.16	10.21	QP



Test Mode :	Mode 3	Temperature :	24~25
Test Engineer :	HaoHai YE	Relative Humidity :	50~55
Test Voltage :	120Vac / 60Hz	Phase :	Neutral
Function Type :	GSM850 Idle + Bluetooth Link + WLAN Link(2.4GHz) + Earphone1 + USB Cable1 (Charging from Adapter3)		

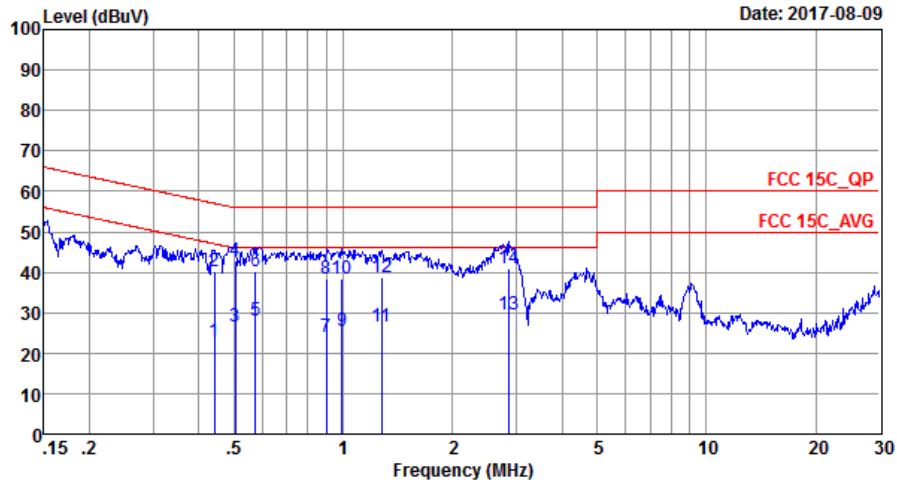

Site : CO01-SZ  
 Condition: FCC 15C\_QP LISN\_20170301\_N NEUTRAL

Mode : Mode 3  
 IMEI : 358410080036725/358410080036733

	Freq	Level	Over Limit	Limit Line	Read Level	LISN Factor	Cable Loss	Remark
	MHz	dBuV	dB	dBuV	dBuV	dB	dB	
1	0.44	22.91	-24.11	47.02	12.70	0.02	10.19	Average
2	0.44	40.31	-16.71	57.02	30.10	0.02	10.19	QP
3	0.50	26.60	-19.40	46.00	16.40	0.02	10.18	Average
4 *	0.50	42.90	-13.10	56.00	32.70	0.02	10.18	QP
5	0.57	28.19	-17.81	46.00	18.00	0.02	10.17	Average
6	0.57	40.29	-15.71	56.00	30.10	0.02	10.17	QP
7	0.90	23.90	-22.10	46.00	13.71	0.04	10.15	Average
8	0.90	38.50	-17.50	56.00	28.31	0.04	10.15	QP
9	0.99	25.60	-20.40	46.00	15.40	0.05	10.15	Average
10	0.99	38.50	-17.50	56.00	28.30	0.05	10.15	QP
11	1.28	26.60	-19.40	46.00	16.40	0.05	10.15	Average
12	1.28	38.90	-17.10	56.00	28.70	0.05	10.15	QP
13	2.85	29.34	-16.66	46.00	19.10	0.03	10.21	Average
14	2.85	40.94	-15.06	56.00	30.70	0.03	10.21	QP



## **3.7 Antenna Requirements**

### **3.7.1 Standard Applicable**

If directional gain of transmitting antennas is greater than 6dBi, the power shall be reduced by the same level in dB comparing to gain minus 6dBi. For the fixed point-to-point operation, the power shall be reduced by one dB for every 3 dB that the directional gain of the antenna exceeds 6 dBi. The use of a permanently attached antenna or of an antenna that uses a unique coupling to the intentional radiator shall be considered sufficient to comply with the rule.

### **3.7.2 Antenna Anti-Replacement Construction**

An embedded-in antenna design is used.

### **3.7.3 Antenna Gain**

The antenna peak gain of EUT is less than 6 dBi. Therefore, it is not necessary to reduce maximum peak output power limit.





## 4 List of Measuring Equipment

Instrument	Manufacturer	Model No.	Serial No.	Characteristics	Calibration Date	Test Date	Due Date	Remark
Spectrum Analyzer	R&S	FSV40	101078	9kHz~40GHz	Apr. 20, 2017	Jul. 31, 2017	Apr. 19, 2018	Conducted (TH01-SZ)
Pulse Power Sensor	Anritsu	MA2411B	1207253	30MHz~40GHz	Jan. 06, 2017	Jul. 31, 2017	Jan. 05, 2018	Conducted (TH01-SZ)
Power Meter	Anritsu	ML2495A	1218010	50MHz Bandwidth	Jan. 06, 2017	Jul. 31, 2017	Jan. 05, 2018	Conducted (TH01-SZ)
EMI Test Receiver&SA	KEYSIGHT	N9038A	MY54450083	20Hz~8.4GHz	Apr. 20, 2017	Aug. 23, 2017	Apr. 19, 2018	Radiation (03CH03-SZ)
EXA Spectrum Analyzer	KEYSIGHT	N9010A	MY55150246	10Hz~44GHz;	Apr. 20, 2017	Aug. 23, 2017	Apr. 19, 2018	Radiation (03CH03-SZ)
Loop Antenna	R&S	HFH2-Z2	100354	9kHz~30MHz	May 14, 2017	Aug. 23, 2017	May 13, 2018	Radiation (03CH03-SZ)
Bilog Antenna	TeseQ	CBL6112D	35408	30MHz-2GHz	May 14, 2017	Aug. 23, 2017	May 13, 2018	Radiation (03CH03-SZ)
Double Ridge Horn Antenna	SCHWARZBECK	BBHA 9120D	9120D-1285	1GHz~18GHz	Jan. 12, 2017	Aug. 23, 2017	Jan. 11, 2018	Radiation (03CH03-SZ)
SHF-EHF Horn	com-power	AH-840	101071	18GHz-40GHz	Jun.16, 2017	Aug. 23, 2017	Jun.15, 2018	Radiation (03CH03-SZ)
Amplifier	Burgeon	BPA-530	102210	0.01Hz~3000MHz	Oct. 11, 2016	Aug. 23, 2017	Oct. 10, 2017	Radiation (03CH03-SZ)
HF Amplifier	MITEQ	AMF-7D-00101800-30-10P-R	1943528	1GHz~18GHz	Oct. 11, 2016	Aug. 23, 2017	Oct. 10, 2017	Radiation (03CH03-SZ)
Amplifier	Agilent Technologies	83017A	MY39501302	500MHz~26.5GHz	Jan. 06, 2017	Aug. 23, 2017	Jan. 05, 2018	Radiation (03CH03-SZ)
HF Amplifier	MITEQ	TTA1840-35-HG	1988315	18GHz~40GHz	Jul. 27, 2017	Aug. 23, 2017	Jul. 26, 2018	Radiation (03CH03-SZ)
AC Power Source	Chroma	61601	616010001985	N/A	NCR	Aug. 23, 2017	NCR	Radiation (03CH03-SZ)
Turn Table	EM	EM1000	N/A	0~360 degree	NCR	Aug. 23, 2017	NCR	Radiation (03CH03-SZ)
Antenna Mast	EM	EM1000	N/A	1 m~4 m	NCR	Aug. 23, 2017	NCR	Radiation (03CH03-SZ)
EMI Receiver	R&S	ESR7	101630	9kHz~7GHz;	Jan. 06, 2017	Aug. 09, 2017	Jan. 05, 2018	Conduction (CO01-SZ)
AC LISN	EMCO	3816/2SH	00103912	9kHz~30MHz	Jan. 05, 2017	Aug. 09, 2017	Jan. 04, 2018	Conduction (CO01-SZ)
AC LISN (for auxiliary equipment)	MessTec	3816/2SH	00103892	9kHz~30MHz	Jan. 05, 2017	Aug. 09, 2017	Jan. 04, 2018	Conduction (CO01-SZ)
AC Power Source	Chroma	61602	616020000891	100Vac~250Vac	Jul. 19, 2017	Aug. 09, 2017	Jul. 18, 2018	Conduction (CO01-SZ)
Pulse Limiter	COM-POWER	LIT-153 Transient Limiter	53139	150kHz~30MHz	Oct.11, 2016	Aug. 09, 2017	Oct.10, 2017	Conduction (CO01-SZ)
RF Cable	Woken	B0720#0001	CO01SZ0007	150kHz~30MHz	Oct. 08, 2016	Aug. 09, 2017	Oct. 09, 2017	Conduction (CO01-SZ)

NCR: No Calibration Required



## 5 Uncertainty of Evaluation

### Uncertainty of Conducted Emission Measurement (150 kHz ~ 30 MHz)

Measuring Uncertainty for a Level of Confidence of 95% (U = 2Uc(y))	2.5dB
---	-------

### Uncertainty of Radiated Emission Measurement (30 MHz ~ 1000 MHz)

Measuring Uncertainty for a Level of Confidence of 95% (U = 2Uc(y))	5.1dB
---	-------

### Uncertainty of Radiated Emission Measurement (1 GHz ~ 18 GHz)

Measuring Uncertainty for a Level of Confidence of 95% (U = 2Uc(y))	5.0dB
---	-------

### Uncertainty of Radiated Emission Measurement (18 GHz ~ 40 GHz)

Measuring Uncertainty for a Level of Confidence of 95% (U = 2Uc(y))	5.0dB
---	-------



## **Appendix A. Conducted Test Results**

**A1 - DTS Part**

Test Engineer:	Sam Zheng	Temperature:	24~26	°C
Test Date:	2017/7/31	Relative Humidity:	50~53	%

**TEST RESULTS DATA**  
**6dB and 99% Occupied Bandwidth**

2.4GHz Band								
Mod.	Data Rate	N <sub>TX</sub>	CH.	Freq. (MHz)	99% Occupied BW (MHz)	6dB BW (MHz)	6dB BW Limit (MHz)	Pass/Fail
11b	1Mbps	1	1	2412	14.29	9.53	0.50	Pass
11b	1Mbps	1	6	2437	14.49	10.03	0.50	Pass
11b	1Mbps	1	11	2462	13.59	9.49	0.50	Pass
11g	6Mbps	1	1	2412	18.73	16.42	0.50	Pass
11g	6Mbps	1	6	2437	18.98	16.34	0.50	Pass
11g	6Mbps	1	11	2462	19.13	16.44	0.50	Pass
HT20	MCS0	1	1	2412	19.78	17.58	0.50	Pass
HT20	MCS0	1	6	2437	19.78	17.56	0.50	Pass
HT20	MCS0	1	11	2462	19.68	17.58	0.50	Pass
HT40	MCS0	1	3	2422	37.16	35.13	0.50	Pass
HT40	MCS0	1	6	2437	37.26	35.33	0.50	Pass
HT40	MCS0	1	9	2452	37.26	35.49	0.50	Pass

**TEST RESULTS DATA**  
**Peak Power Table**

2.4GHz Band										
Mod.	Data Rate	NTX	CH.	Freq. (MHz)	Peak Conducted Power (dBm)	Conducted Power Limit (dBm)	DG (dBi)	EIRP Power (dBm)	EIRP Power Limit (dBm)	Pass /Fail
11b	1Mbps	1	1	2412	18.87	30.00	1.38	20.25	36.00	Pass
11b	1Mbps	1	6	2437	18.78	30.00	1.38	20.16	36.00	Pass
11b	1Mbps	1	11	2462	19.85	30.00	1.38	21.23	36.00	Pass
11g	6Mbps	1	1	2412	20.84	30.00	1.38	22.22	36.00	Pass
11g	6Mbps	1	6	2437	22.25	30.00	1.38	23.63	36.00	Pass
11g	6Mbps	1	11	2462	22.20	30.00	1.38	23.58	36.00	Pass
HT20	MCS0	1	1	2412	20.72	30.00	1.38	22.10	36.00	Pass
HT20	MCS0	1	6	2437	22.14	30.00	1.38	23.52	36.00	Pass
HT20	MCS0	1	11	2462	22.12	30.00	1.38	23.50	36.00	Pass
HT40	MCS0	1	3	2422	19.31	30.00	1.38	20.69	36.00	Pass
HT40	MCS0	1	6	2437	21.42	30.00	1.38	22.80	36.00	Pass
HT40	MCS0	1	9	2452	21.92	30.00	1.38	23.30	36.00	Pass

**TEST RESULTS DATA**  
**Average Power Table**  
**(Reporting Only)**

2.4GHz Band						
Mod.	Data Rate	N <sub>TX</sub>	CH.	Freq. (MHz)	Duty Factor (dB)	Average Conducted Power (dBm)
11b	1Mbps	1	1	2412	0.11	15.94
11b	1Mbps	1	6	2437	0.11	16.29
11b	1Mbps	1	11	2462	0.11	16.58
11g	6Mbps	1	1	2412	0.58	12.12
11g	6Mbps	1	6	2437	0.58	14.68
11g	6Mbps	1	11	2462	0.58	14.63
HT20	MCS0	1	1	2412	0.63	11.68
HT20	MCS0	1	6	2437	0.63	13.86
HT20	MCS0	1	11	2462	0.63	13.79
HT40	MCS0	1	3	2422	1.19	9.62
HT40	MCS0	1	6	2437	1.19	12.51
HT40	MCS0	1	9	2452	1.19	13.85

**TEST RESULTS DATA**  
**Peak Power Density**

2.4GHz Band								
Mod.	Data Rate	NTX	CH.	Freq. (MHz)	Peak PSD (dBm /3kHz)	DG (dBi)	Peak PSD Limit (dBm /3kHz)	Pass/Fail
11b	1Mbps	1	1	2412	-7.22	1.38	8.00	Pass
11b	1Mbps	1	6	2437	-6.57	1.38	8.00	Pass
11b	1Mbps	1	11	2462	-6.46	1.38	8.00	Pass
11g	6Mbps	1	1	2412	-12.12	1.38	8.00	Pass
11g	6Mbps	1	6	2437	-9.37	1.38	8.00	Pass
11g	6Mbps	1	11	2462	-12.43	1.38	8.00	Pass
HT20	MCS0	1	1	2412	-12.92	1.38	8.00	Pass
HT20	MCS0	1	6	2437	-10.03	1.38	8.00	Pass
HT20	MCS0	1	11	2462	-12.94	1.38	8.00	Pass
HT40	MCS0	1	3	2422	-14.77	1.38	8.00	Pass
HT40	MCS0	1	6	2437	-11.78	1.38	8.00	Pass
HT40	MCS0	1	9	2452	-15.10	1.38	8.00	Pass





# Appendix B. Radiated Spurious Emission

## 2.4GHz 2400~2483.5MHz

### WIFI 802.11b (Band Edge @ 3m)

WIFI	Note	Frequency	Level	Over	Limit	Read	Antenna	Cable	Preamp	Ant	Table	Peak	Pol.
Ant.				Limit	Line	Level	Factor	Loss	Factor	Pos	Pos	Avg.	
1		( MHz )	( dBμV/m )	( dB )	( dBμV/m )	( dBμV )	( dB/m )	( dB )	( dB )	( cm )	( deg )	(P/A)	(H/V)
802.11b CH 01 2412MHz		2389.275	50.08	-23.92	74	51.73	27.51	5.06	34.22	241	226	P	H
		2388.12	40.91	-13.09	54	42.56	27.51	5.06	34.22	241	226	A	H
	*	2412	102.34	-	-	103.91	27.57	5.06	34.2	241	226	P	H
	*	2412	99.22	-	-	100.79	27.57	5.06	34.2	241	226	A	H
		2387.91	50.54	-23.46	74	52.19	27.51	5.06	34.22	150	269	P	V
		2388.12	41.28	-12.72	54	42.93	27.51	5.06	34.22	150	269	A	V
	*	2412	102.53	-	-	104.1	27.57	5.06	34.2	150	269	P	V
	*	2412	99.4	-	-	100.97	27.57	5.06	34.2	150	269	A	V
802.11b CH 06 2437MHz		2384.48	49.98	-24.02	74	51.74	27.44	5.02	34.22	212	223	P	H
		2389.94	39.21	-14.79	54	40.84	27.51	5.06	34.2	212	223	A	H
	*	2437	105.13	-	-	106.49	27.7	5.12	34.18	212	223	P	H
	*	2437	101.99	-	-	103.35	27.7	5.12	34.18	212	223	A	H
		2489.71	50.88	-23.12	74	51.92	27.9	5.19	34.13	212	223	P	H
		2492.44	39.34	-14.66	54	40.36	27.9	5.19	34.11	212	223	A	H
		2383.5	49.62	-24.38	74	51.38	27.44	5.02	34.22	135	272	P	V
		2389.8	39.21	-14.79	54	40.84	27.51	5.06	34.2	135	272	A	V
	*	2437	105.8	-	-	107.16	27.7	5.12	34.18	135	272	P	V
	*	2437	102.64	-	-	104	27.7	5.12	34.18	135	272	A	V
		2490.34	50.71	-23.29	74	51.75	27.9	5.19	34.13	135	272	P	V
	2492.51	39.56	-14.44	54	40.58	27.9	5.19	34.11	135	272	A	V	



802.11b CH 11 2462MHz	*	2462	101.11	-	-	102.37	27.77	5.12	34.15	207	214	P	H
	*	2462	97.95	-	-	99.21	27.77	5.12	34.15	207	214	A	H
		2489.68	50.55	-23.45	74	51.59	27.9	5.19	34.13	207	214	P	H
		2484.2	39.84	-14.16	54	40.95	27.83	5.19	34.13	207	214	A	H
	*	2462	102.94	-	-	104.2	27.77	5.12	34.15	248	233	P	V
	*	2462	99.86	-	-	101.12	27.77	5.12	34.15	248	233	A	V
		2493.32	52.72	-21.28	74	53.74	27.9	5.19	34.11	248	233	P	V
		2495.96	39.96	-14.04	54	40.98	27.9	5.19	34.11	248	233	A	V
<b>Remark</b>	<ol style="list-style-type: none"> <li>No other spurious found.</li> <li>All results are PASS against Peak and Average limit line.</li> </ol>												



2.4GHz 2400~2483.5MHz
WIFI 802.11b (Harmonic @ 3m)

Table with 14 columns: WIFI Ant. 1, Note, Frequency (MHz), Level (dBµV/m), Over Limit (dB), Limit Line (dBµV/m), Read Level (dBµV), Antenna Factor (dB/m), Cable Loss (dB), Preamp Factor (dB), Ant Pos (cm), Table Pos (deg), Peak Avg. (P/A), Pol. (H/V). Rows include data for CH 01 (2412MHz) and CH 06 (2437MHz) with multiple frequency entries.

Remark

- 1. No other spurious found.
2. All results are PASS against Peak and Average limit line.



**2.4GHz 2400~2483.5MHz  
WIFI 802.11g (Band Edge @ 3m)**

WIFI Ant. 1	Note	Frequency ( MHz )	Level ( dBμV/m )	Over Limit ( dB )	Limit Line ( dBμV/m )	Read Level ( dBμV )	Antenna Factor ( dB/m )	Cable Loss ( dB )	Preamp Factor ( dB )	Ant Pos ( cm )	Table Pos ( deg )	Peak Avg. ( P/A )	Pol. ( H/V )
802.11g CH 01 2412MHz		2389.8	65.23	-8.77	74	66.86	27.51	5.06	34.2	244	226	P	H
		2390	51.45	-2.55	54	53.08	27.51	5.06	34.2	244	226	A	H
	*	2412	102.51	-	-	104.08	27.57	5.06	34.2	244	226	P	H
	*	2412	94.86	-	-	96.43	27.57	5.06	34.2	244	226	A	H
		2390	64.09	-9.91	74	65.72	27.51	5.06	34.2	204	269	P	V
		2390	51.04	-2.96	54	52.67	27.51	5.06	34.2	204	269	A	V
	*	2412	102.56	-	-	104.13	27.57	5.06	34.2	204	269	P	V
	*	2412	95.27	-	-	96.84	27.57	5.06	34.2	204	269	A	V
802.11g CH 06 2437MHz		2389.38	50.56	-23.44	74	52.21	27.51	5.06	34.22	256	221	P	H
		2384.9	40.91	-13.09	54	42.63	27.44	5.06	34.22	256	221	A	H
	*	2437	104.48	-	-	105.9	27.64	5.12	34.18	256	221	P	H
	*	2437	96.6	-	-	98.02	27.64	5.12	34.18	256	221	A	H
		2495.24	50.1	-23.9	74	51.12	27.9	5.19	34.11	256	221	P	H
		2489.08	40.53	-13.47	54	41.57	27.9	5.19	34.13	256	221	A	H
		2389.8	52.28	-21.72	74	53.91	27.51	5.06	34.2	173	266	P	V
		2384.76	41.26	-12.74	54	42.98	27.44	5.06	34.22	173	266	A	V
	*	2437	105.59	-	-	107.01	27.64	5.12	34.18	173	266	P	V
	*	2437	97.81	-	-	99.23	27.64	5.12	34.18	173	266	A	V
		2493.7	50.35	-23.65	74	51.37	27.9	5.19	34.11	173	266	P	V
		2489.29	41.06	-12.94	54	42.1	27.9	5.19	34.13	173	266	A	V



802.11g CH 11 2462MHz	*	2462	101.64	-	-	102.81	27.77	5.19	34.13	258	232	P	H
	*	2462	94.41	-	-	95.58	27.77	5.19	34.13	258	232	A	H
		2483.72	61.62	-12.38	74	62.73	27.83	5.19	34.13	258	232	P	H
		2483.56	46.82	-7.18	54	47.93	27.83	5.19	34.13	258	232	A	H
	*	2462	103.66	-	-	104.92	27.77	5.12	34.15	157	268	P	V
	*	2462	96.03	-	-	97.29	27.77	5.12	34.15	157	268	A	V
		2483.72	60.75	-13.25	74	61.86	27.83	5.19	34.13	157	268	P	V
		2483.72	46.99	-7.01	54	48.1	27.83	5.19	34.13	157	268	A	V
<b>Remark</b>	<ol style="list-style-type: none"> <li>No other spurious found.</li> <li>All results are PASS against Peak and Average limit line.</li> </ol>												



2.4GHz 2400~2483.5MHz  
WIFI 802.11g (Harmonic @ 3m)

WIFI Ant. 1	Note	Frequency ( MHz )	Level ( dBμV/m )	Over Limit ( dB )	Limit Line ( dBμV/m )	Read Level ( dBμV )	Antenna Factor ( dB/m )	Cable Loss ( dB )	Preamp Factor ( dB )	Ant Pos ( cm )	Table Pos ( deg )	Peak Avg. (P/A)	Pol. (H/V)
802.11g CH 01 2412MHz		4824	40.5	-33.5	74	58.66	31.59	8.59	58.34	159	360	P	H
		4824	39.18	-34.82	74	57.34	31.59	8.59	58.34	159	360	P	V
802.11g CH 06 2437MHz		4874	40.02	-33.98	74	58.04	31.71	8.6	58.33	158	360	P	H
		7311	45.42	-28.58	74	58.31	36.27	10.24	59.4	174	100	P	H
		4874	39.52	-34.48	74	57.54	31.71	8.6	58.33	100	360	P	V
802.11g CH 11 2462MHz		7311	46.71	-27.29	74	59.6	36.27	10.24	59.4	174	100	P	V
		4924	41.07	-32.93	74	58.93	31.83	8.64	58.33	161	360	P	H
		7386	45.13	-28.87	74	57.99	36.38	10.2	59.44	145	274	P	H
		4924	40.71	-33.29	74	58.57	31.83	8.64	58.33	161	360	P	V
802.11g CH 11 2462MHz		7386	45.82	-28.18	74	58.68	36.38	10.2	59.44	145	274	P	V
	<b>Remark</b> 1. No other spurious found. 2. All results are PASS against Peak and Average limit line.												



2.4GHz 2400~2483.5MHz  
WIFI 802.11n HT20 (Band Edge @ 3m)

WIFI Ant. 1	Note	Frequency ( MHz )	Level ( dBμV/m )	Over Limit ( dB )	Limit Line ( dBμV/m )	Read Level ( dBμV )	Antenna Factor ( dB/m )	Cable Loss ( dB )	Preamp Factor ( dB )	Ant Pos ( cm )	Table Pos ( deg )	Peak Avg. ( P/A )	Pol. ( H/V )
802.11n HT20 CH 01 2412MHz		2389.8	64.19	-9.81	74	65.82	27.51	5.06	34.2	175	157	P	H
		2389.59	51.02	-2.98	54	52.67	27.51	5.06	34.22	175	157	A	H
	*	2412	101.13	-	-	102.7	27.57	5.06	34.2	175	157	P	H
		2412	93.37	-	-	94.94	27.57	5.06	34.2	175	157	A	H
		2389.8	63.88	-10.12	74	65.51	27.51	5.06	34.2	147	289	P	V
		2390	51.63	-2.37	54	53.26	27.51	5.06	34.2	147	289	A	V
	*	2412	102.37	-	-	103.94	27.57	5.06	34.2	147	289	P	V
	*	2412	94.66	-	-	96.23	27.57	5.06	34.2	147	289	A	V
802.11n HT20 CH 06 2437MHz		2385.18	50.82	-23.18	74	52.54	27.44	5.06	34.22	165	154	P	H
		2385.46	41.46	-12.54	54	43.18	27.44	5.06	34.22	165	154	A	H
	*	2437	102.59	-	-	103.95	27.7	5.12	34.18	165	154	P	H
	*	2437	94.97	-	-	96.33	27.7	5.12	34.18	165	154	A	H
		2494.47	50.05	-23.95	74	51.07	27.9	5.19	34.11	165	154	P	H
		2489.29	40.6	-13.4	54	41.64	27.9	5.19	34.13	165	154	A	H
		2389.66	50.17	-23.83	74	51.82	27.51	5.06	34.22	145	286	P	V
		2385.46	41.71	-12.29	54	43.43	27.44	5.06	34.22	145	286	A	V
	*	2437	104.5	-	-	105.86	27.7	5.12	34.18	145	286	P	V
		2437	96.74	-	-	98.1	27.7	5.12	34.18	145	286	A	V
		2488.45	50.26	-23.74	74	51.3	27.9	5.19	34.13	145	286	P	V
	2489.01	40.54	-13.46	54	41.58	27.9	5.19	34.13	145	286	A	V	



802.11n HT20 CH 11 2462MHz	*	2462	101.65	-	-	102.91	27.77	5.12	34.15	141	154	P	H
	*	2462	93.83	-	-	95.09	27.77	5.12	34.15	141	154	A	H
		2483.92	60.65	-13.35	74	61.76	27.83	5.19	34.13	141	154	P	H
		2484	45.16	-8.84	54	46.27	27.83	5.19	34.13	141	154	A	H
	*	2462	102.91	-	-	104.17	27.77	5.12	34.15	136	247	P	V
	*	2462	95.27	-	-	96.53	27.77	5.12	34.15	136	247	A	V
		2484.6	62.55	-11.45	74	63.66	27.83	5.19	34.13	136	247	P	V
	2483.52	46.39	-7.61	54	47.5	27.83	5.19	34.13	136	247	A	V	
<b>Remark</b>	<ol style="list-style-type: none"> <li>No other spurious found.</li> <li>All results are PASS against Peak and Average limit line.</li> </ol>												





**2.4GHz 2400~2483.5MHz  
WIFI 802.11n HT20 (Harmonic @ 3m)**

WIFI Ant. 1	Note	Frequency ( MHz )	Level ( dBμV/m )	Over Limit ( dB )	Limit Line ( dBμV/m )	Read Level ( dBμV )	Antenna Factor ( dB/m )	Cable Loss ( dB )	Preamp Factor ( dB )	Ant Pos ( cm )	Table Pos ( deg )	Peak Avg. ( P/A )	Pol. ( H/V )
802.11n HT20 CH 01 2412MHz		4824	42.52	-31.48	74	60.68	31.59	8.59	58.34	161	360	P	H
		4824	39.99	-34.01	74	58.15	31.59	8.59	58.34	161	360	P	V
802.11n HT20 CH 06 2437MHz		4874	39.44	-34.56	74	57.46	31.71	8.6	58.33	159	360	P	H
		7311	45.78	-28.22	74	58.67	36.27	10.24	59.4	174	100	P	H
		4874	40.21	-33.79	74	58.23	31.71	8.6	58.33	159	360	P	V
		7311	45.92	-28.08	74	58.81	36.27	10.24	59.4	174	100	P	V
802.11n HT20 CH 11 2462MHz		4924	40.46	-33.54	74	58.32	31.83	8.64	58.33	159	360	P	H
		7386	46.02	-27.98	74	58.88	36.38	10.2	59.44	145	274	P	H
		4924	40.14	-33.86	74	58	31.83	8.64	58.33	159	360	P	V
		7386	45.66	-28.34	74	58.52	36.38	10.2	59.44	145	274	P	V
<b>Remark</b>	1. No other spurious found. 2. All results are PASS against Peak and Average limit line.												



**2.4GHz 2400~2483.5MHz  
WIFI 802.11n HT40 (Band Edge @ 3m)**

WIFI Ant. 1	Note	Frequency ( MHz )	Level ( dBμV/m )	Over Limit ( dB )	Limit Line ( dBμV/m )	Read Level ( dBμV )	Antenna Factor ( dB/m )	Cable Loss ( dB )	Preamp Factor ( dB )	Ant Pos ( cm )	Table Pos ( deg )	Peak Avg. ( P/A )	Pol. ( H/V )
802.11n HT40 CH 03 2422MHz		2388.54	59.85	-14.15	74	61.5	27.51	5.06	34.22	168	215	P	H
		2389.94	49.25	-4.75	54	50.88	27.51	5.06	34.2	168	215	A	H
	*	2422	98.26	-	-	99.74	27.64	5.06	34.18	168	215	P	H
	*	2422	90.75	-	-	92.23	27.64	5.06	34.18	168	215	A	H
		2484.32	50.03	-23.97	74	51.14	27.83	5.19	34.13	168	215	P	H
		2488.59	40.85	-13.15	54	41.89	27.9	5.19	34.13	168	215	A	H
		2389.94	61.37	-12.63	74	63	27.51	5.06	34.2	139	257	P	V
		2389.1	51.8	-2.2	54	53.45	27.51	5.06	34.22	139	257	A	V
	*	2422	99.87	-	-	101.35	27.64	5.06	34.18	139	257	P	V
	*	2422	92.28	-	-	93.76	27.64	5.06	34.18	139	257	A	V
		2488.31	50.09	-23.91	74	51.13	27.9	5.19	34.13	139	257	P	V
		2490.69	41.14	-12.86	54	42.18	27.9	5.19	34.13	139	257	A	V
802.11n HT40 CH 06 2437MHz		2389.24	59.43	-14.57	74	61.08	27.51	5.06	34.22	171	217	P	H
		2389.8	49.96	-4.04	54	51.59	27.51	5.06	34.2	171	217	A	H
	*	2437	101.27	-	-	102.6	27.7	5.12	34.15	171	217	P	H
	*	2437	93.62	-	-	94.98	27.7	5.12	34.18	171	217	A	H
		2484.81	51.33	-22.67	74	52.44	27.83	5.19	34.13	171	217	P	H
		2483.5	42.69	-11.31	54	43.8	27.83	5.19	34.13	171	217	A	H
		2389.52	61.08	-12.92	74	62.73	27.51	5.06	34.22	165	255	P	V
		2389.66	51.43	-2.57	54	53.08	27.51	5.06	34.22	165	255	A	V
	*	2437	102.65	-	-	104.07	27.64	5.12	34.18	165	255	P	V
	*	2437	95.13	-	-	96.55	27.64	5.12	34.18	165	255	A	V
		2483.62	53.34	-20.66	74	54.45	27.83	5.19	34.13	165	255	P	V
		2483.69	42.52	-11.48	54	43.63	27.83	5.19	34.13	165	255	A	V



802.11n HT40 CH 09 2452MHz		2389.66	54.25	-19.75	74	55.9	27.51	5.06	34.22	170	216	P	H
		2389.1	44.76	-9.24	54	46.41	27.51	5.06	34.22	170	216	A	H
	*	2452	102.56	-	-	103.89	27.7	5.12	34.15	170	216	P	H
	*	2452	95.11	-	-	96.44	27.7	5.12	34.15	170	216	A	H
		2485.37	62.59	-11.41	74	63.7	27.83	5.19	34.13	170	216	P	H
		2483.69	50.01	-3.99	54	51.12	27.83	5.19	34.13	170	216	A	H
		2389.8	54.37	-19.63	74	56	27.51	5.06	34.2	167	268	P	V
		2387.98	45.43	-8.57	54	47.08	27.51	5.06	34.22	167	268	A	V
	*	2452	103.56	-	-	104.89	27.7	5.12	34.15	167	268	P	V
	*	2452	95.97	-	-	97.3	27.7	5.12	34.15	167	268	A	V
		2496.22	61.45	-12.55	74	62.47	27.9	5.19	34.11	167	268	P	V
		2483.5	49.11	-4.89	54	50.22	27.83	5.19	34.13	167	268	A	V
<b>Remark</b>	1. No other spurious found. 2. All results are PASS against Peak and Average limit line.												



2.4GHz 2400~2483.5MHz
WIFI 802.11n HT40 (Harmonic @ 3m)

Table with 14 columns: WIFI Ant. 1, Note, Frequency (MHz), Level (dBµV/m), Over Limit (dB), Limit Line (dBµV/m), Read Level (dBµV), Antenna Factor (dB/m), Cable Loss (dB), Preamp Factor (dB), Ant Pos (cm), Table Pos (deg), Peak Avg. (P/A), Pol. (H/V). Rows include test results for 802.11n HT40 CH 03 (2422MHz) and CH 06 (2437MHz), and 802.11n HT40 CH 09 (2452MHz).

Remark

- 1. No other spurious found.
2. All results are PASS against Peak and Average limit line.



Emission below 1GHz

2.4GHz WIFI 802.11n HT40 (LF)

WIFI	Note	Frequency	Level	Over	Limit	Read	Antenna	Cable	Preamp	Ant	Table	Peak	Pol.
Ant.				Limit	Line	Level	Factor	Loss	Factor	Pos	Pos	Avg.	
1		( MHz )	( dBμV/m )	( dB )	( dBμV/m )	( dBμV )	( dB/m )	( dB )	( dB )	( cm )	( deg )	( P/A )	( H/V )
2.4GHz 802.11n HT40 LF		30	26.56	-13.44	40	31.3	26.7	0.56	32	130	44	P	H
		90.14	30.01	-13.49	43.5	43.01	17.8	0.98	31.78	-	-	P	H
		161.92	28.47	-15.03	43.5	41.35	17.28	1.32	31.48	-	-	P	H
		409.27	27.67	-18.33	46	30.96	25.79	2.15	31.23	-	-	P	H
		705.12	30.68	-15.32	46	31.4	27.66	2.87	31.25	-	-	P	H
		993.21	32.87	-21.13	54	30.36	30.27	3.47	31.23	-	-	P	H
		42.61	32.19	-7.81	40	42.69	20.82	0.67	31.99	170	80	P	V
		90.14	26.31	-17.19	43.5	39.31	17.8	0.98	31.78	-	-	P	V
		147.37	26.53	-16.97	43.5	38.93	17.86	1.26	31.52	-	-	P	V
		195.87	29.76	-13.74	43.5	43.88	15.77	1.45	31.34	-	-	P	V
		417.03	27.77	-18.23	46	31.2	25.62	2.17	31.22	-	-	P	V
		690.57	31.49	-14.51	46	32.66	27.24	2.84	31.25	-	-	P	V
Remark	1. No other spurious found. 2. All results are PASS against limit line.												



Note symbol

*	<b>Fundamental Frequency</b> which can be ignored. However, the level of any unwanted emissions shall not exceed the level of the fundamental frequency.
!	Test result is <b>over limit</b> line.
P/A	<b>Peak</b> or <b>Average</b>
H/V	<b>Horizontal</b> or <b>Vertical</b>



A calculation example for radiated spurious emission is shown as below:

WIFI	Note	Frequency	Level	Over	Limit	Read	Antenna	Cable	Preamp	Ant	Table	Peak	Pol.
Ant.				Limit	Line	Level	Factor	Loss	Factor	Pos	Pos	Avg.	
1		( MHz )	( dBμV/m )	( dB )	( dBμV/m )	( dBμV )	( dB/m )	( dB )	( dB )	( cm )	( deg )	( P/A )	( H/V )
802.11b		2390	55.45	-18.55	74	54.51	32.22	4.58	35.86	103	308	P	H
CH 01													
2412MHz		2390	43.54	-10.46	54	42.6	32.22	4.58	35.86	103	308	A	H

- Level(dBμV/m) =  
Antenna Factor(dB/m) + Cable Loss(dB) + Read Level(dBμV) - Preamp Factor(dB)
- Over Limit(dB) = Level(dBμV/m) – Limit Line(dBμV/m)

**For Peak Limit @ 2390MHz:**

- Level(dBμV/m)  
= Antenna Factor(dB/m) + Cable Loss(dB) + Read Level(dBμV) - Preamp Factor(dB)  
= 32.22(dB/m) + 4.58(dB) + 54.51(dBμV) – 35.86 (dB)  
= 55.45 (dBμV/m)
- Over Limit(dB)  
= Level(dBμV/m) – Limit Line(dBμV/m)  
= 55.45(dBμV/m) – 74(dBμV/m)  
= -18.55(dB)

**For Average Limit @ 2390MHz:**

- Level(dBμV/m)  
= Antenna Factor(dB/m) + Cable Loss(dB) + Read Level(dBμV) - Preamp Factor(dB)  
= 32.22(dB/m) + 4.58(dB) + 42.6(dBμV) – 35.86 (dB)  
= 43.54 (dBμV/m)
- Over Limit(dB)  
= Level(dBμV/m) – Limit Line(dBμV/m)  
= 43.54(dBμV/m) – 54(dBμV/m)  
= -10.46(dB)

Both peak and average measured complies with the limit line, so test result is “PASS”.



## Appendix C. Duty Cycle Plots

Band	Duty Cycle(%)	T(ms)	1/T(kHz)	VBW Setting
802.11b	100	-	-	10Hz
802.11g	87.50	1.370	0.730	1kHz
802.11n HT20	86.27	1.275	0.784	1kHz
802.11n HT40	75.78	0.635	1.575	3kHz





802.11b

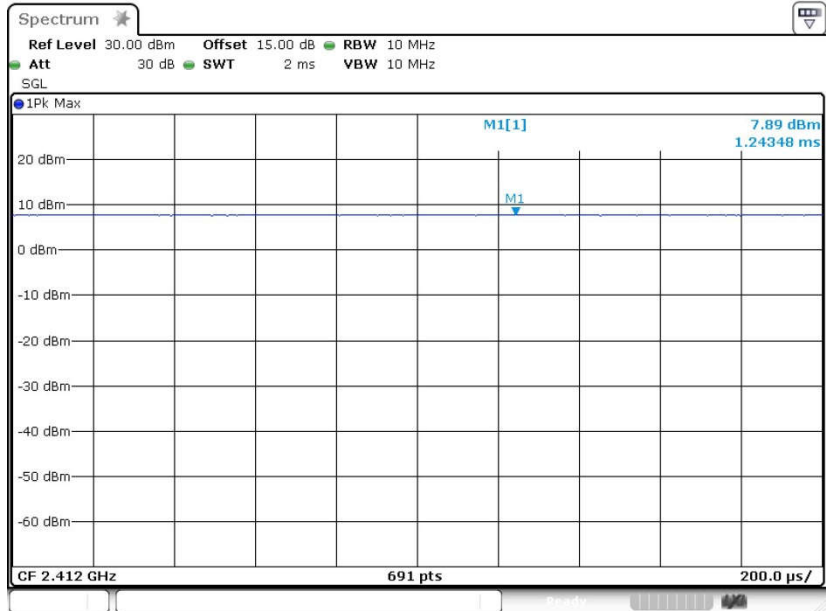



802.11g

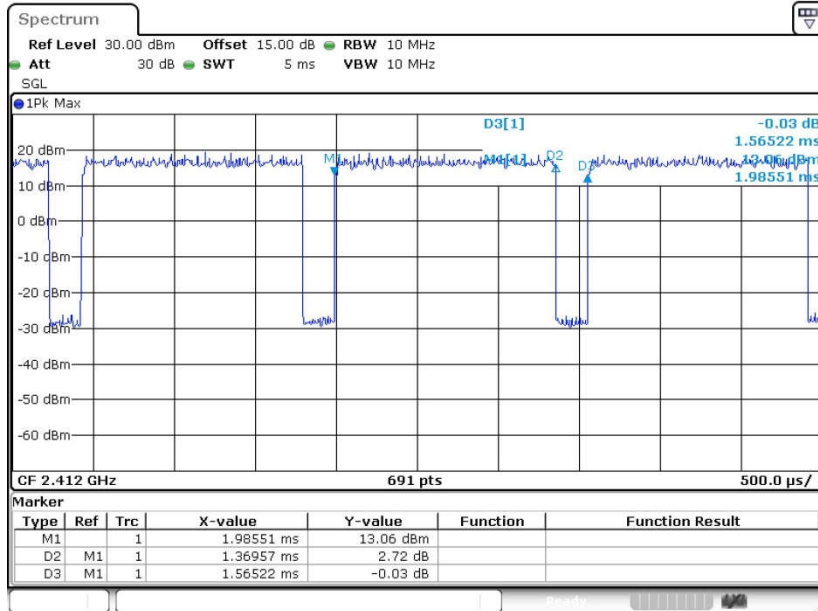

802.11n HT20

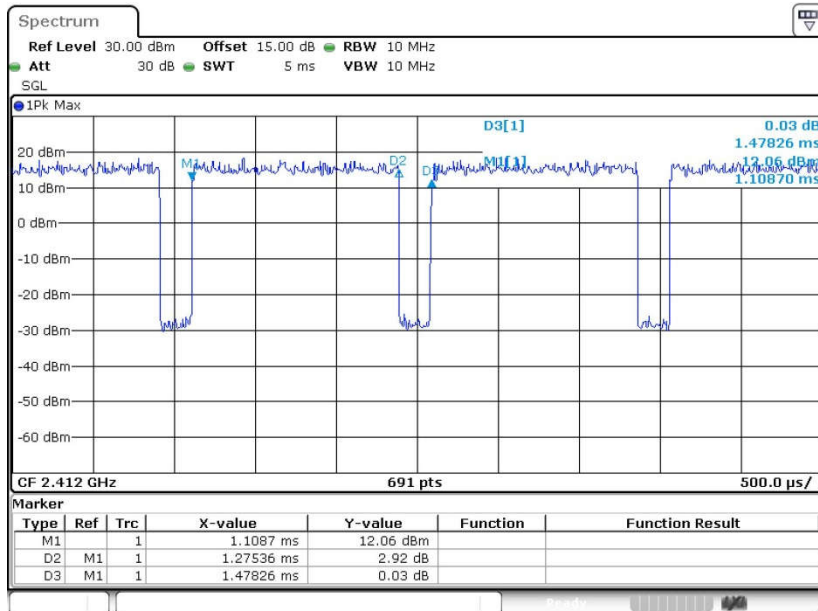



802.11n HT40

