



# FCC TEST REPORT

for

## 47 CFR Part 22H, 24E

**Equipment** : Quad-band Smart Phone  
**Trade Name** : ASUS  
**Model No.** : P527  
**FCC ID** : MSQP527  
**Tx Frequency Range** : GSM850 : 824.2~848.8 MHz  
PCS1900 : 1850.2~1909.8 MHz  
**Max. ERP/EIRP Power** : GSM850(GSM) : 0.63 W  
GSM850(EDGE) : 0.16 W  
PCS1900(GSM) : 1.53 W  
PCS1900(EDGE) : 0.53 W  
**Emission Designator** : GSM : 300KGXW  
EDGE : 300KG7W  
**Applicant** : ASUSTek COMPUTER INC.  
4F., No. 150, Li-Te Rd., Peitou, Taipei, Taiwan

- The test result refers exclusively to the test presented test model / sample.
- Without written approval of SPORTON International Inc., the test report shall not be reproduced except in full.
- **Certificate or Test Report must not be used by the applicant to claim the product in this test report endorsement by NVLAP or any agency of U.S. government.**
- The data shown in this test report were carried out on Oct. 02, 2007 at **Sporton International Inc. LAB.**
- Report No.: FG781408A, Report Version: Rev. 01.

Jones Tsai  
Manager

### **SPORTON International Inc.**

6F, No.106, Sec. 1, Hsin Tai Wu Rd., Hsi Chih, Taipei Hsien, Taiwan, R.O.C.



## Table of Contents

**History of this test report .....ii**

**1. General Information.....1**

    1.2 Applicant.....1

    1.3 Manufacturer .....1

    1.4 Basic Description of Equipment under Test.....1

    1.5 Feature of Equipment under Test.....2

    1.6 Report Date .....2

**2. Test Configuration of Equipment under Test.....3**

    2.1 Test Manner .....3

    2.2 Test Mode .....3

    2.3 Connection Diagram of Test System .....3

    2.4 Ancillary Equipment List .....4

**3. General Information of Test Site .....5**

    3.1 Test Voltage .....5

    3.2 Test Compliance .....5

    3.3 Frequency Range .....5

    3.4 Test Distance .....5

**4. Test Data and Test Result.....6**

    4.1 List of Measurements and Examinations .....6

    4.2 RF Output Power.....7

    4.3 ERP / EIRP Measurement.....9

    4.4 Occupied Bandwidth and Band Edge Measurement .....13

    4.5 Conducted Emission.....58

    4.6 Field Strength of Spurious Radiation .....77

    4.7 Frequency Stability (Temperature Variation) .....91

    4.8 Frequency Stability (Voltage Variation) .....94

**5. List of Measurement Equipments .....96**

**6. Uncertainty Evaluation .....97**

**Appendix A - External Photographs**

**Appendix B - Internal Photographs**

**Appendix C - Setup Photographs**



### History of this test report

Report Issue Date: Oct. 04, 2007

Report No.	Description



## 1. General Information

### 1.2 Applicant

**ASUSTek COMPUTER INC.**  
4F., No. 150, Li-Te Rd., Peitou, Taipei, Taiwan

### 1.3 Manufacturer

1. **ASUSTeK Computer Inc.**  
No. 5, Shing Yeh Street, 333 Kwei Shan Hsiang, Taoyuan Hsien, Taiwan
2. **ProTek (Shanghai) Ltd.**  
No.3768, Xiu Yan Road, Nanhui District, 201315 Shanghai, People's Republic of China
3. **MainTek Computer (Suzhou) Co., Ltd.**  
No. 233 Jing Feng Road · 215011 Suzhou New District, Jiangsu, People's Republic of China

### 1.4 Basic Description of Equipment under Test

<b>Equipment</b>		Quad-band Smart Phone
<b>Trade Name</b>		ASUS
<b>Model Name</b>		P527
<b>FCC ID</b>		MSQP527
<b>AC Adapter</b>	<b>Brand Name</b>	TPT
	<b>Model Name</b>	JSP050090UU
	<b>ASUS P/N</b>	04G267013800
	<b>Power Rating</b>	I/P:100-240Vac, 50-60Hz, 0.3A O/P: 5Vdc, 0.9A, 4.5W
	<b>AC Power Cord Type</b>	1.65 meter shielded cable without ferrite non-core
<b>Car Charger</b>	<b>Brand Name</b>	L&K
	<b>Model Name</b>	G12PCL-530-0011
	<b>ASUS P/N</b>	04G267011910
	<b>Power Rating</b>	I/P: 12V/24V; O/P: 5V, 900mA
	<b>Power Cord Type</b>	0.6 meter non-shielded cable without ferrite non-core
<b>Battery</b>	<b>Brand Name</b>	ASUS
	<b>Model Name</b>	SBP-06
	<b>ASUS P/N</b>	07G016043459
	<b>Rating</b>	3.7Vdc, 1300mAh
	<b>Type</b>	Li-ion
<b>Earphone</b>	<b>Brand Name</b>	ASUS
	<b>ASUS P/N</b>	04G170012520
	<b>Signal line Type</b>	1.8 meter non-shielded cable without ferrite non-core
<b>USB Cable</b>	<b>Brand Name</b>	Foxconn
	<b>ASUS P/N</b>	14G000506200
	<b>Signal line Type</b>	0.7 meter shielded cable with ferrite core
<b>Holster</b>	<b>Brand Name</b>	ASUS
	<b>ASUS P/N</b>	15G180904400
	<b>Color</b>	Black

Remark: Above EUT's information was declared by manufacturer. Please refer to the specifications of manufacturer or User's Manual for more detailed features description.



### 1.5 Feature of Equipment under Test

<b>DUT Type :</b>	Quad-band Smart Phone
<b>Trade Name :</b>	ASUS
<b>Model Name :</b>	P527
<b>FCC ID :</b>	MSQP527
<b>Tx Frequency :</b>	GSM850 : 824 ~ 849 MHz PCS1900 : 1850 ~1910 MHz WLAN / Bluetooth : 2400 ~ 2483.5 MHz
<b>Rx Frequency :</b>	GSM850 : 869 ~ 894 MHz PCS1900 : 1930 ~ 1990 MHz WLAN / Bluetooth : 2400 ~ 2483.5 MHz
<b>Maximum Output Power to Antenna :</b>	GSM850 : 32.44 dBm (GSM) / 32.49 dBm (GPRS) / 26.04 dBm (EDGE) PCS1900 : 29.39 dBm (GSM) / 29.45 dBm (GPRS) / 25.10 dBm (EDGE) WLAN : 20.57 dBm (802.11b) / 22.81 dBm (802.11g) Bluetooth : 1.35 dBm (1Mbps) Bluetooth EDR : 2.21 dBm (2Mbps) / 2.45 dBm (3Mbps)
<b>Maximum ERP/EIRP :</b>	GSM850(GSM) : 0.63 W ( 27.97 dBm) GSM850(EDGE) : 0.16 W ( 22.08 dBm) PCS1900(GSM) : 1.53 W ( 31.86 dBm) PCS1900(EDGE) : 0.53 W ( 27.25 dBm)
<b>GPRS / EGPRS Multislot class :</b>	10
<b>HW Version :</b>	Rev: 1.02
<b>SW Version :</b>	3.12.070809.000S-FTA
<b>Antenna Type :</b>	GSM : Fixed Internal Bluetooth : PIFA Antenna WLAN : PIFA Antenna
<b>Type of Antenna Connector</b>	N/A
<b>Power Rating (DC/AC , Voltage and Current of RF element or PA) :</b>	DC 3.8V / 270mA
<b>Modulation Type :</b>	GSM / GPRS : GMSK EDGE : 8PSK WLAN : DSSS / OFDM Bluetooth (1Mbps) : GFSK Bluetooth EDR (2Mbps) : Pi/4-DQPSK Bluetooth EDR (3Mbps) : 8-DPSK
<b>Emission Designator :</b>	GSM : 300KGXW EDGE : 300KG7W
<b>Device Power Class :</b>	GSM850 : 4 PCS1900 : 1

### 1.6 Report Date

EUT Received : Aug. 14, 2007

Report Date : Oct. 04, 2007

## 2. Test Configuration of Equipment under Test

### 2.1 Test Manner

1. The spurious emission measurements were carried out in semi-anechoic chamber with 3-meter test range.
2. During all testings, EUT is in link mode with base station emulator at maximum power level.
3. Frequency range investigated: radiated emission 30 MHz to 9000 MHz for GSM850 and 30MHz to 19000 MHz for PCS1900.

### 2.2 Test Mode

Application	GSM850	PCS1900
Radiated Emission	<input checked="" type="checkbox"/> Mode 1: GSM Link	<input checked="" type="checkbox"/> Mode 3: GSM Link
	<input checked="" type="checkbox"/> Mode 2: EDGE Link	<input checked="" type="checkbox"/> Mode 4: EDGE Link
	<input checked="" type="checkbox"/> Mode 5: GSM Link + WLAN Link	
Conducted Measurement	<input checked="" type="checkbox"/> Mode 1: GSM Link	<input checked="" type="checkbox"/> Mode 3: GSM Link
	<input checked="" type="checkbox"/> Mode 2: EDGE Link	<input checked="" type="checkbox"/> Mode 4: EDGE Link

### 2.3 Connection Diagram of Test System

<GSM Link Mode>

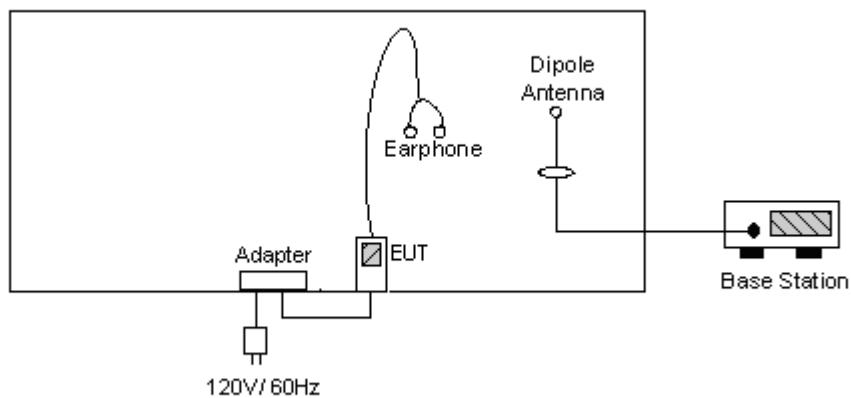

**<GSM with Bluetooth Link Mode>**

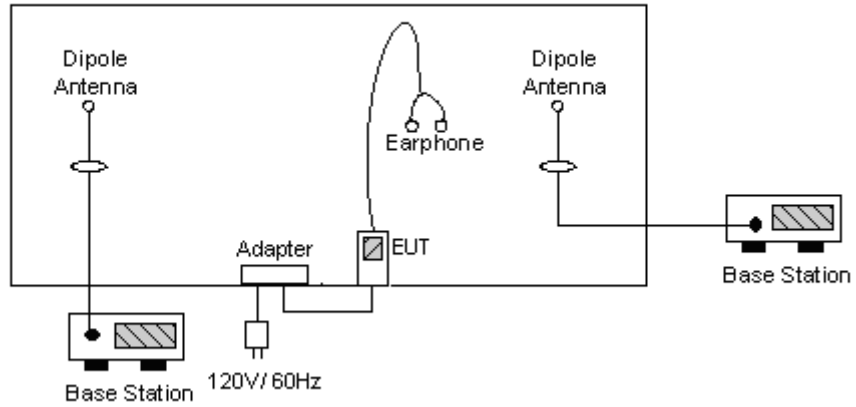

**2.4 Ancillary Equipment List**

Item	Equipment	Trade Name	Model No.	FCC ID	Cable Cord / Power Code
1.	Base Station	R&S	CMU200	N/A	Unshielded, 1.8m
2.	BT Base Station	Anritus	8852A	N/A	Unshielded, 1.8m



### **3. General Information of Test Site**

Test Site Location : No. 52, Hwa Ya 1st Rd., Hwa Ya Technology Park,  
Kwei-Shan Hsiang, Tao Yuan Hsien, Taiwan, R.O.C.  
TEL : 886-3-327-3456  
FAX : 886-3-318-0055  
Test Site No : 03CH06-HY

The chamber meets the characteristics of ANSI C63.4-2003. This site is on file with the FCC.

#### **3.1 Test Voltage**

AC 120V / 60Hz

#### **3.2 Test Compliance**

47 CFR Part 22H, 24E, Part 2

#### **3.3 Frequency Range**

- a. Radiation: from 30MHz to 9000MHz for GSM850.
- b. Radiation: from 30 MHz to 19000 MHz for PCS1900.

#### **3.4 Test Distance**

The test distance of radiated emission from antenna to EUT is 3 m.





## 4. Test Data and Test Result

### 4.1 List of Measurements and Examinations

FCC Rule	Description of Test	Result	Section
§2.1046	RF Output Power	Passed	4.2
§ 22.913 §24.232	ERP / EIRP	Passed	4.3
§2.1049, § 22.917, § 24.238(b)	Occupied Bandwidth & Band Edge Measurement	Passed	4.4
§2.1051	Conducted Emission	Passed	4.5
§2.1053	Field Strength of Spurious Radiation	Passed	4.6
§2.1055, § 22.355, §24.235	Frequency Stability vs. Temperature	Passed	4.7
§2.1055, §22.355, §24.235	Frequency Stability vs. Voltage	Passed	4.8

## 4.2 RF Output Power

### 4.2.1 Measurement Instruments :

As described in chapter 5 of this test report.

### 4.2.2 Test Procedure :

1. The transmitter output was connected to power meter and base station through power divider.
2. Set EUT at PCL=5 for GSM850 and/or PCL=0 for PCS1900 maximum power through base station.
3. Select lowest, middle, and highest channels for each band.

### 4.2.3 Test Setup Layout :

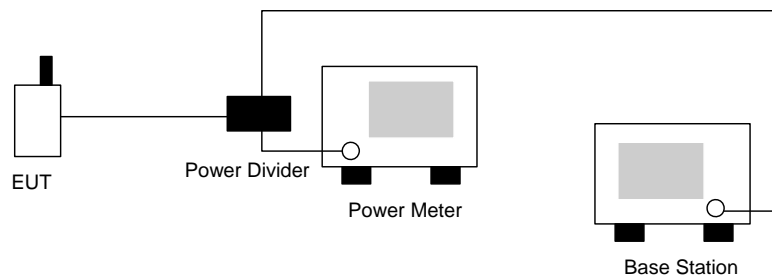



4.2.4 Test Result :

Bands	Channel	Frequency (MHz)	Conducted Power (dBm)	Conducted Power (Watts)
GSM850 (GSM)	128	824.2 (Low)	32.37	1.726
	189	836.4 (Mid)	32.44	1.754
	251	848.8 (High)	32.43	1.750
GSM850 (EDGE)	128	824.2 (Low)	25.89	0.388
	189	836.4 (Mid)	25.84	0.384
	251	848.8 (High)	26.04	0.402
PCS1900 (GSM)	512	1850.2 (Low)	29.12	0.817
	661	1880.0 (Mid)	29.23	0.838
	810	1909.8 (High)	29.39	0.869
PCS1900 (EDGE)	512	1850.2 (Low)	24.82	0.303
	661	1880.0 (Mid)	25.10	0.324
	810	1909.8 (High)	25.01	0.317



### 4.3 ERP / EIRP Measurement

Equivalent isotropic radiated power measurements by substitution method according to ANSI/TIA/EIA-603-C.

#### 4.3.1 Measurement Instruments

As described in chapter 5 of this test report.

#### 4.3.2 Test Procedure

1. The EUT was placed on a table with 1.0 meter height in an fully anechoic chamber.
2. The EUT was set 1.2 meters from the receiving antenna which was mounted on the antenna tower.
3. The table was rotated 360 degrees to determine the position of the highest radiated power.
4. The height of the receiving antenna is also kept at 1.0M height.
5. Taking the record of maximum ERP/EIRP.
6. A dipole antenna was substituted in place of the EUT and was driven by a signal generator.
7. The conducted power at the terminal of the dipole antenna is measured.
8. Repeat step 3 to step 5 to get the maximum ERP/EIRP of the substitution antenna.
9.  $ERP/EIRP = P_s + E_t - E_s + G_s = P_s + R_t - R_s + G_s$

$P_s$  (dBm) : Input power to substitution antenna.

$G_s$  (dBi or dBd) : Substitution antenna Gain.

$E_t = R_t + AF$

$E_s = R_s + AF$

$AF$  (dB/m) : Receive antenna factor

$R_t$  : The highest received signal in Spectrum Analyzer for EUT.

$R_s$  : The highest received signal in spectrum analyzer for substitution antenna.



4.3.3 Test Setup Layout of ERP/EIRP

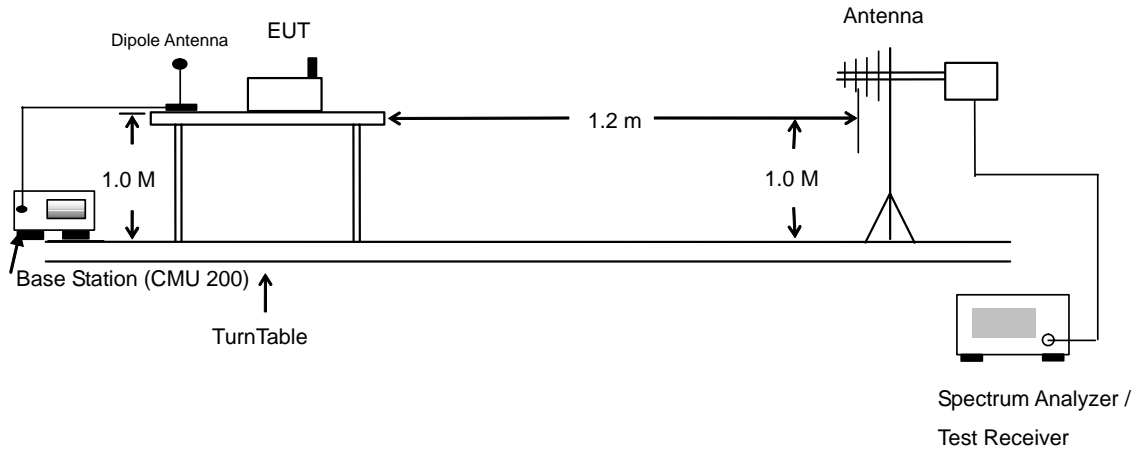



4.3.4 Test Result

<b>GSM850 (GSM) Radiated Power ERP</b>						
Horizontal Polarization						
Frequency (MHz)	Rt (dBm)	Rs (dBm)	Ps (dBm)	Gs (dBd)	ERP (dBm)	ERP (W)
824.20	-30.39	-48.12	0.00	-1.08	16.65	0.05
836.40	-29.60	-48.28	0.00	-0.93	17.75	0.06
848.80	-28.82	-48.35	0.00	-0.76	18.77	0.08
Vertical Polarization						
Frequency (MHz)	Rt (dBm)	Rs (dBm)	Ps (dBm)	Gs (dBd)	ERP (dBm)	ERP (W)
824.20	-20.89	-47.97	0.00	-1.08	26.00	0.40
836.40	-19.84	-48.01	0.00	-0.93	27.24	0.53
848.80	-19.32	-48.05	0.00	-0.76	27.97	0.63

<b>GSM850 (EDGE) Radiated Power ERP</b>						
Horizontal Polarization						
Frequency (MHz)	Rt (dBm)	Rs (dBm)	Ps (dBm)	Gs (dBd)	ERP (dBm)	ERP (W)
824.20	-38.14	-48.12	0.00	-1.08	8.90	0.01
836.40	-38.12	-48.28	0.00	-0.93	9.23	0.01
848.80	-38.00	-48.35	0.00	-0.76	9.59	0.01
Vertical Polarization						
Frequency (MHz)	Rt (dBm)	Rs (dBm)	Ps (dBm)	Gs (dBd)	ERP (dBm)	ERP (W)
824.20	-27.79	-47.97	0.00	-1.08	19.10	0.08
836.40	-25.00	-48.01	0.00	-0.93	22.08	0.16
848.80	-26.05	-48.05	0.00	-0.76	21.24	0.13



PCS1900 (GSM) Radiated Power EIRP						
Horizontal Polarization						
Frequency (MHz)	Rt (dBm)	Rs (dBm)	Ps (dBm)	Gs (dBi)	EIRP (dBm)	EIRP (W)
1850.20	-24.51	-51.88	0.00	1.96	29.33	0.86
1880.00	-25.85	-52.99	0.00	2.00	29.14	0.82
1909.80	-27.89	-54.28	0.00	1.98	28.37	0.69
Vertical Polarization						
Frequency (MHz)	Rt (dBm)	Rs (dBm)	Ps (dBm)	Gs (dBi)	EIRP (dBm)	EIRP (W)
1850.20	-22.23	-52.13	0.00	1.96	31.86	1.53
1880.00	-23.33	-53.17	0.00	2.00	31.84	1.53
1909.80	-25.28	-54.13	0.00	1.98	30.83	1.21

PCS1900 (EDGE) Radiated Power EIRP						
Horizontal Polarization						
Frequency (MHz)	Rt (dBm)	Rs (dBm)	Ps (dBm)	Gs (dBi)	EIRP (dBm)	EIRP (W)
1850.20	-29.12	-51.88	0.00	1.96	24.72	0.30
1880.00	-30.35	-52.99	0.00	2.00	24.64	0.29
1909.80	-32.52	-54.28	0.00	1.98	23.74	0.24
Vertical Polarization						
Frequency (MHz)	Rt (dBm)	Rs (dBm)	Ps (dBm)	Gs (dBi)	EIRP (dBm)	EIRP (W)
1850.20	-26.87	-52.13	0.00	1.96	27.22	0.53
1880.00	-28.08	-53.17	0.00	2.00	27.09	0.51
1909.80	-28.86	-54.13	0.00	1.98	27.25	0.53



## 4.4 Occupied Bandwidth and Band Edge Measurement

### 4.4.1 Measurement Instruments

As described in chapter 5 of this test report.

### 4.4.2 Test Procedure

1. The EUT was connected to Spectrum Analyzer and Base Station via power divider.
2. The 99% occupied bandwidth of middle channel for the highest and lowest RF powers were measured.
3. The bandedge of low and high channels for the highest RF powers within the transmitting frequency band were measured. Setting RBW as roughly BW/100.

### 4.4.3 Test Setup Layout

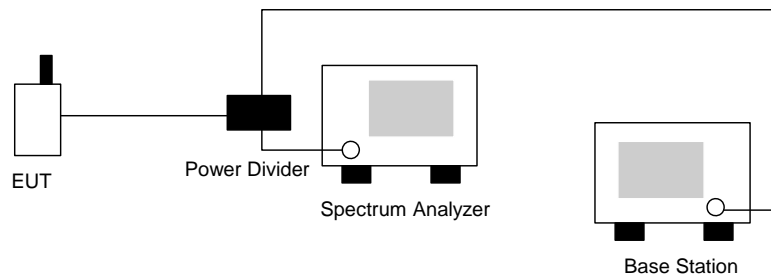





4.4.4 Test Result

- Mode 1
- Test Mode : GSM850 (GSM) CH128 Lower Band Edge
- Power State : High

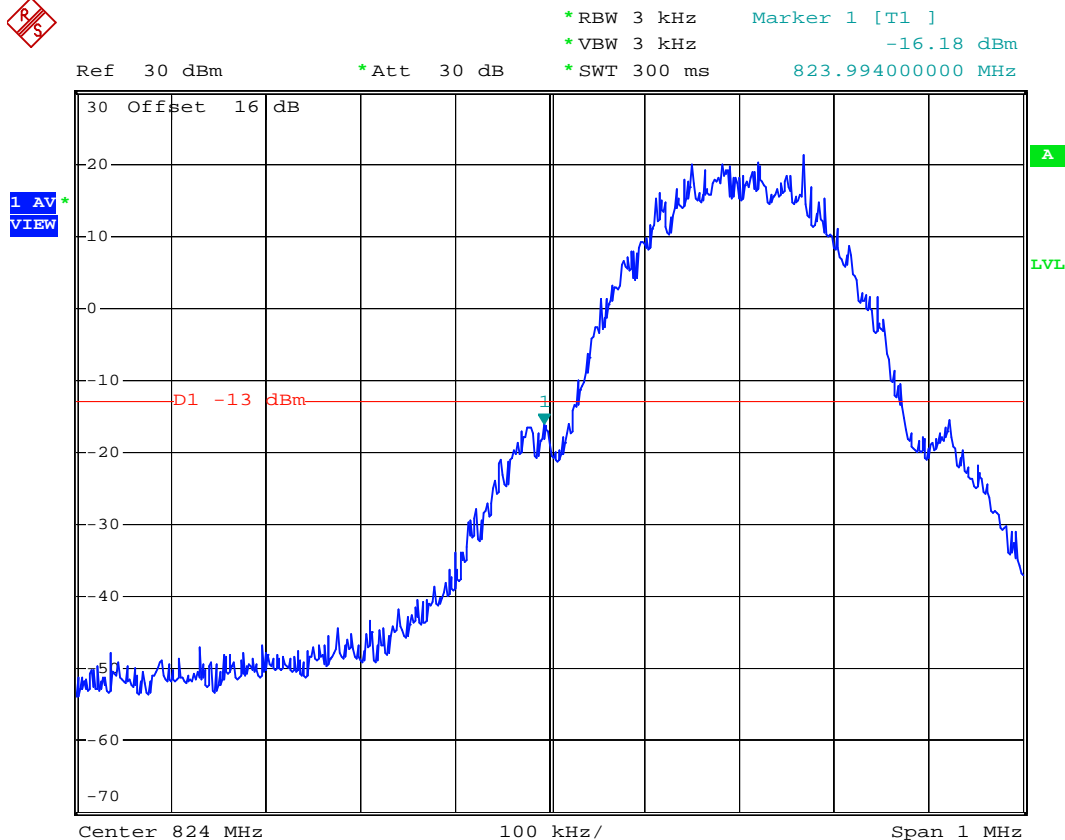

Date: 11.SEP.2007 17:35:17



Ref 30 dBm      \*Att 30 dB      \*RBW 3 kHz      Marker 1 [T1 ]  
\*VBW 10 kHz      -17.54 dBm  
\*SWT 300 ms      823.976000000 MHz

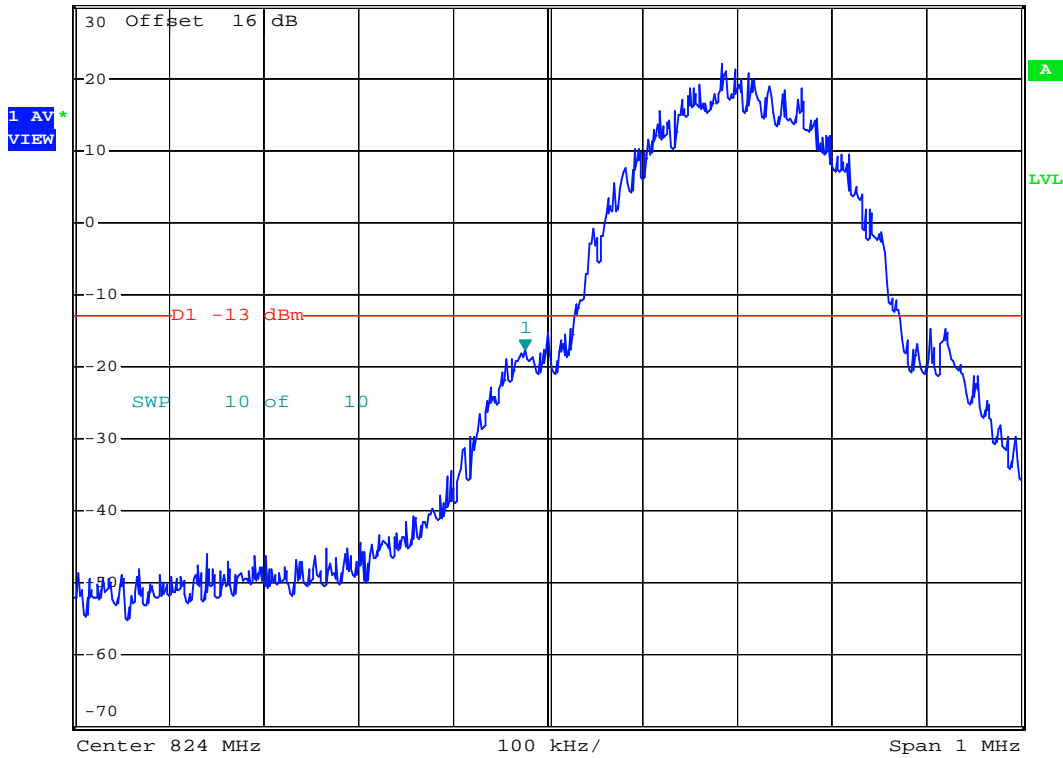

Date: 11.SEP.2007 17:29:30



- Test Mode : GSM850 (GSM) CH128 99% Occupied Bandwidth
- Power State : High

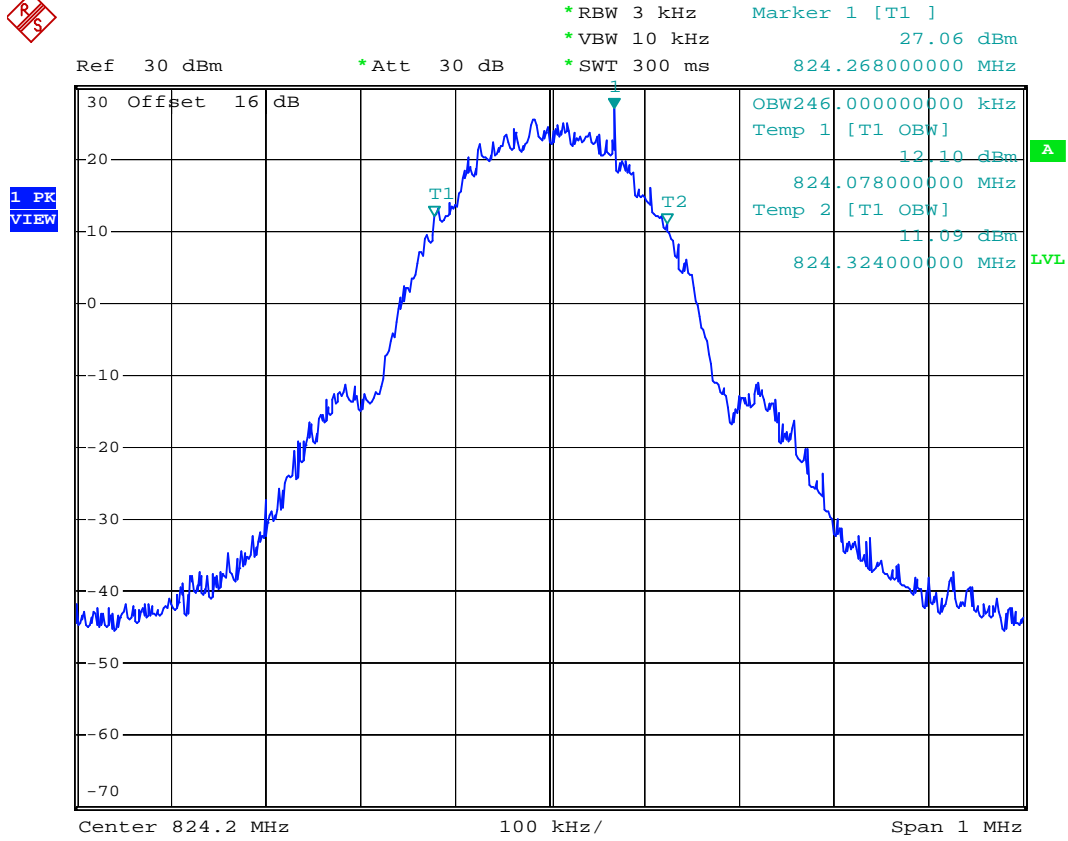

Date: 11.SEP.2007 18:05:06



- Test Mode : GSM850 (GSM) CH189 99% Occupied Bandwidth
- Power State : High

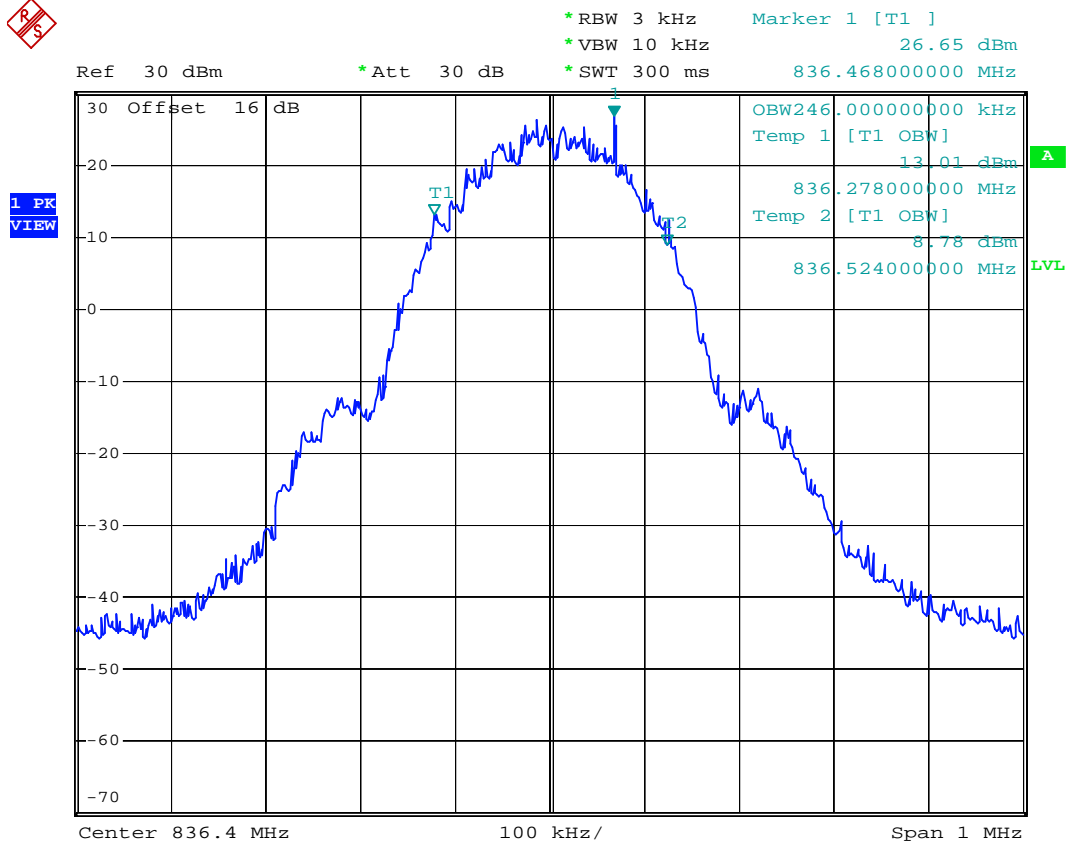

Date: 11.SEP.2007 18:03:19



\*RBW 3 kHz      Marker 1 [T1 ]  
 \*VBW 30 kHz      26.26 dBm  
 \*SWT 300 ms      836.386000000 MHz

Ref 30 dBm

\*Att 30 dB

1 PK  
VIEW

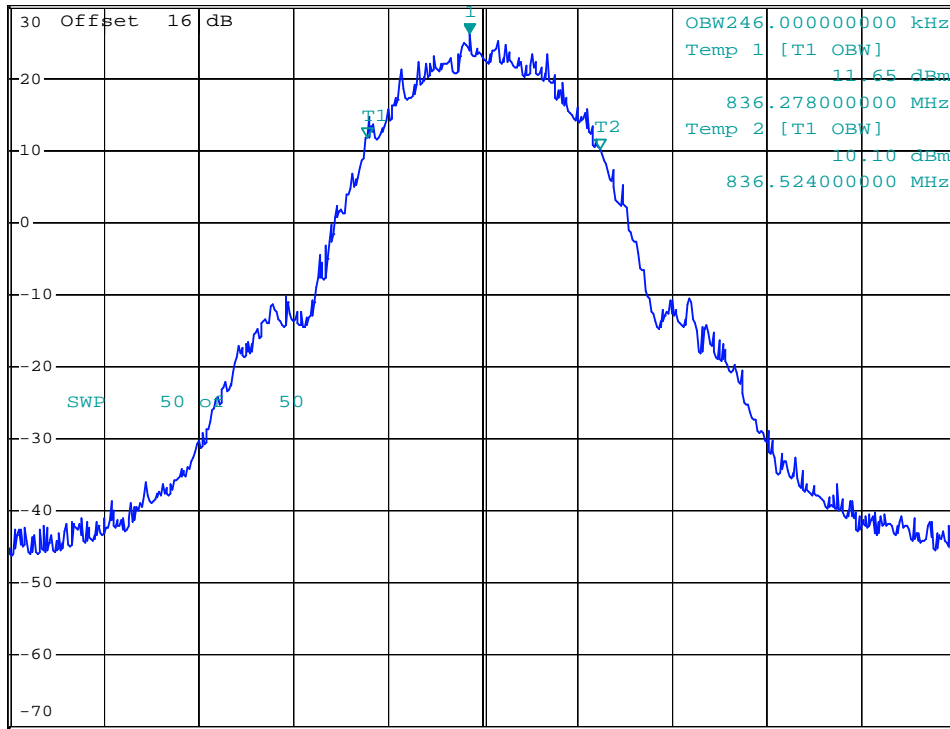

Center 836.4 MHz

100 kHz/

Span 1 MHz

Date: 11.SEP.2007 18:02:20



- Test Mode : GSM850 (GSM) CH 251 99% Occupied Bandwidth
- Power State : High

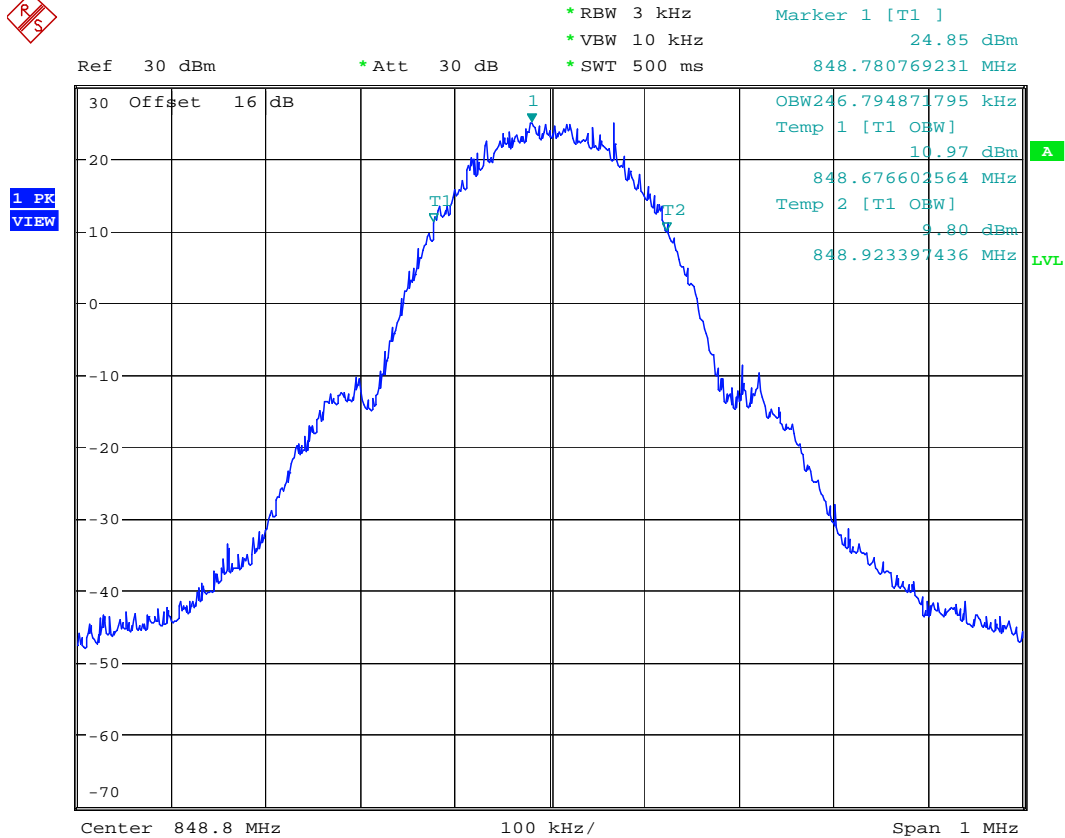

444

Date: 25.SEP.2007 18:14:04



- Test Mode : GSM850 (GSM) CH128 26dB Bandwidth
- Power State : High



\*RBW 3 kHz      Delta 2 [T1 ]  
 \*VBW 10 kHz      1.23 dB  
 \*SWT 300 ms      300.00000000 kHz

Ref 35 dBm

\*Att 30 dB

1 PK  
VIEW

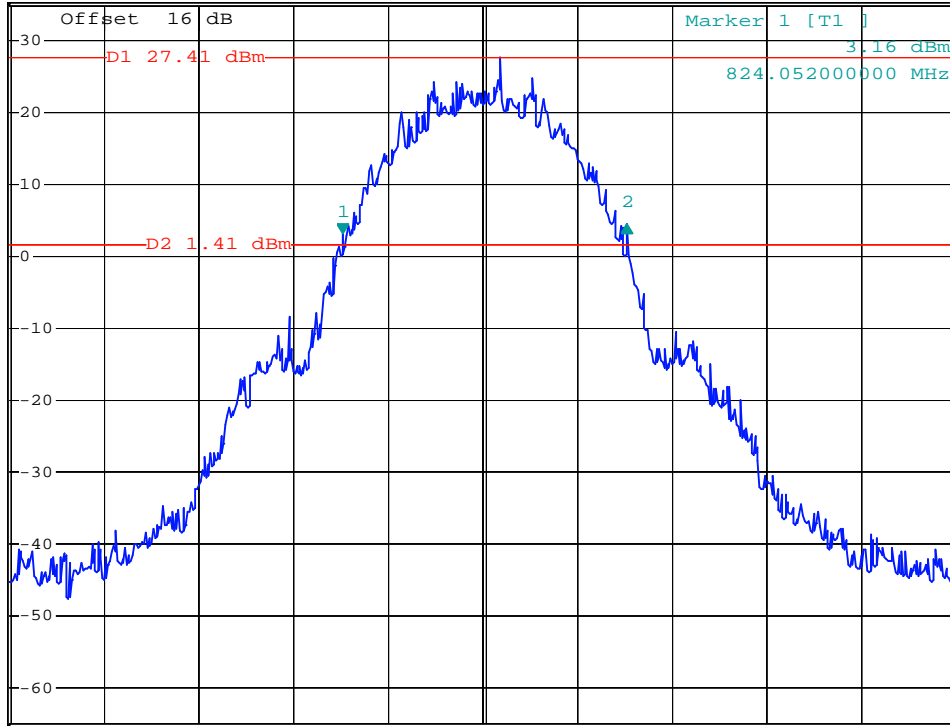

Center 824.2 MHz

100 kHz/

Span 1 MHz

Date: 11.SEP.2007 19:44:05



- Test Mode : GSM850 (GSM) CH189 26dB Bandwidth
- Power State : High

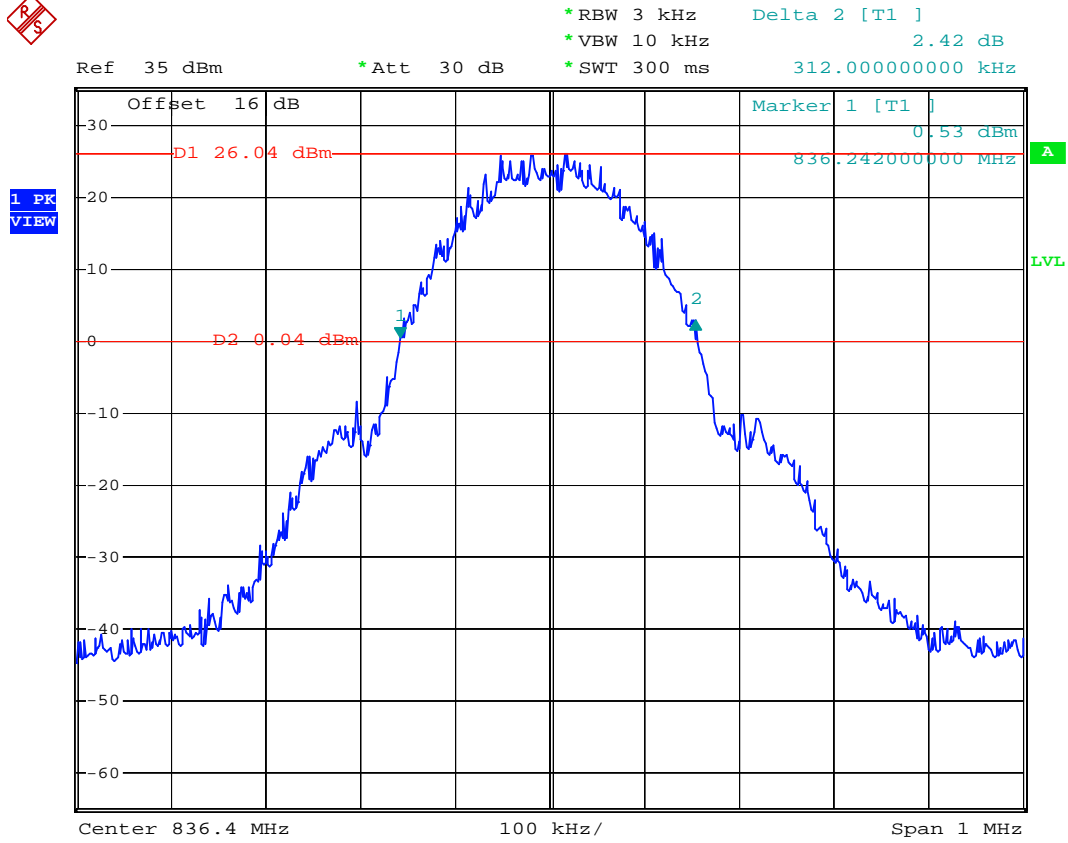

Date: 11.SEP.2007 19:45:39





- Test Mode : GSM850 (GSM) CH 251 26dB Bandwidth
- Power State : High

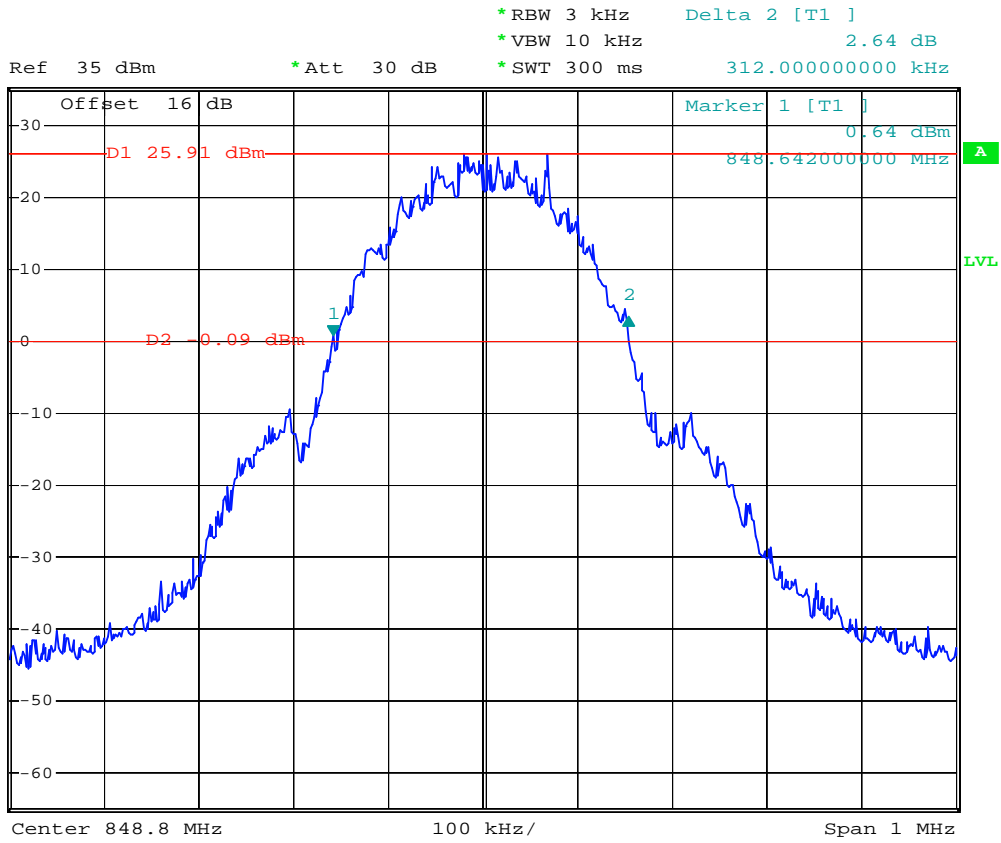

Date: 11.SEP.2007 19:47:19



- Test Mode : GSM850 (GSM) CH251 Higher Band Edge
- Power State : High



\*RBW 3 kHz      Marker 1 [T1 ]  
\*VBW 3 kHz      -15.58 dBm  
\*SWT 300 ms      849.01800000 MHz

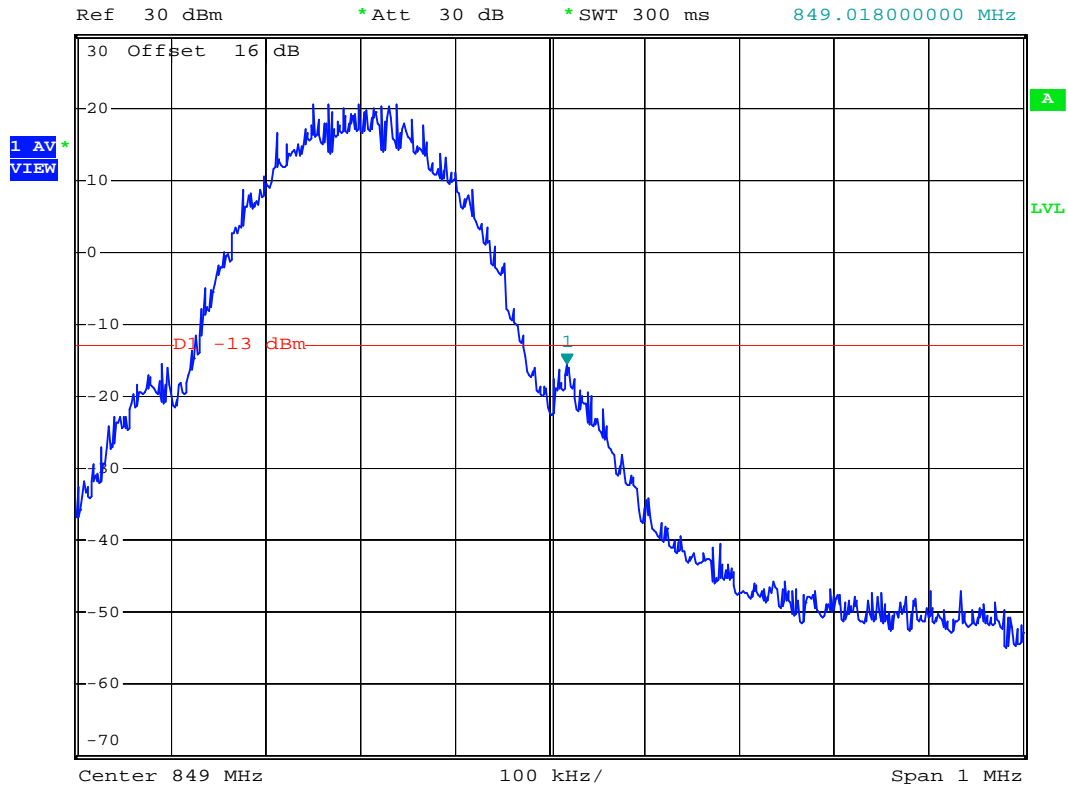

Date: 11.SEP.2007 17:32:36



Ref 30 dBm      \*Att 30 dB      \*RBW 3 kHz      Marker 1 [T1 ]  
\*VBW 10 kHz      -14.71 dBm  
\*SWT 300 ms      849.016000000 MHz

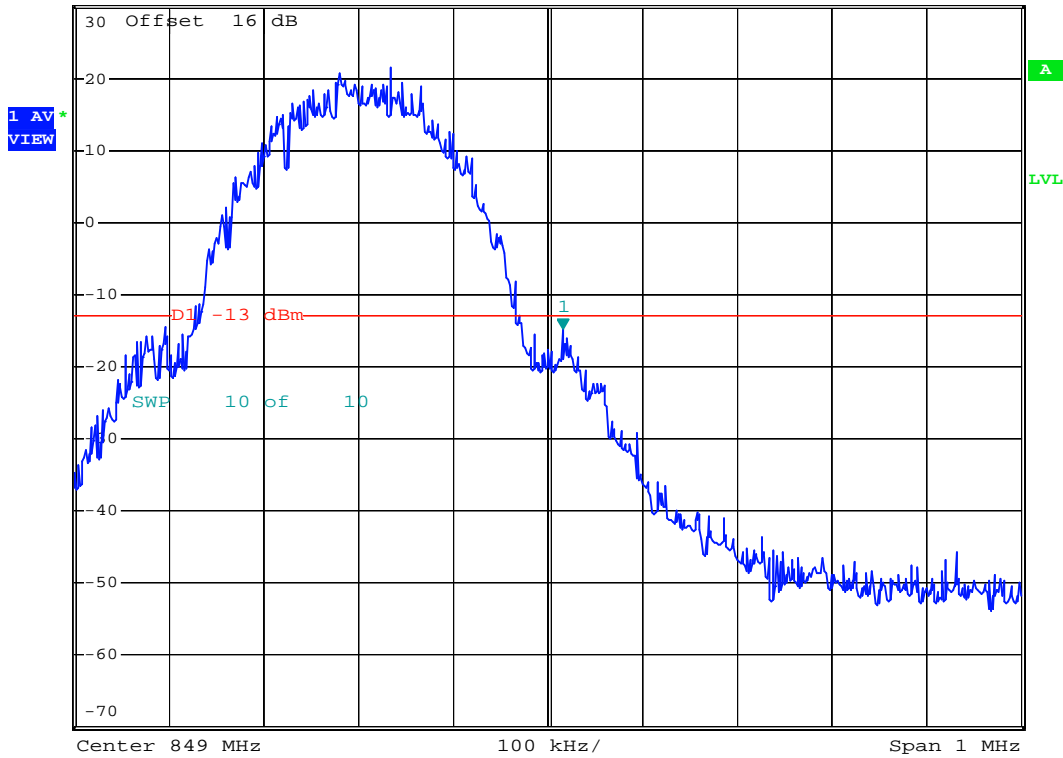

Date: 11.SEP.2007 17:30:48



- Mode 2
- Test Mode : GSM850 (EDGE) CH128 Lower Band Edge
- Power State : High

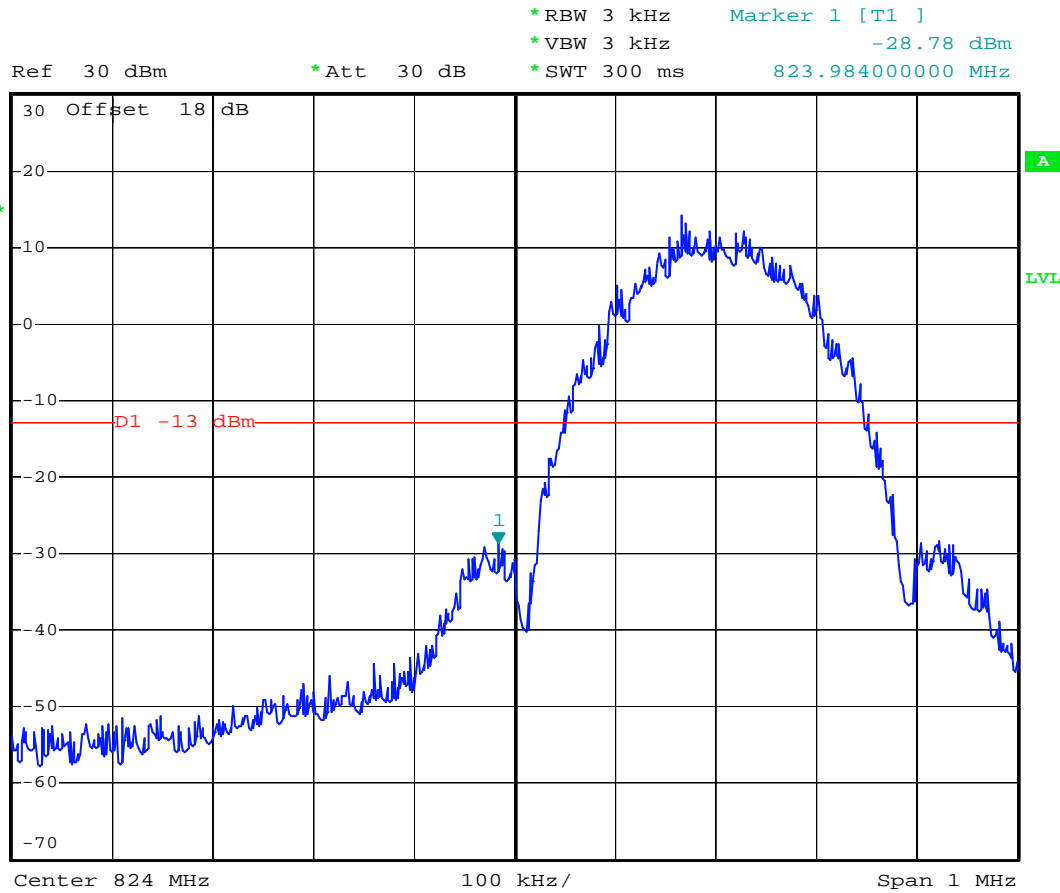

Date: 20.SEP.2007 13:13:29



\*RBW 3 kHz      Marker 1 [T1 ]  
\*VBW 10 kHz      -27.75 dBm  
\*SWT 300 ms      823.99000000 MHz

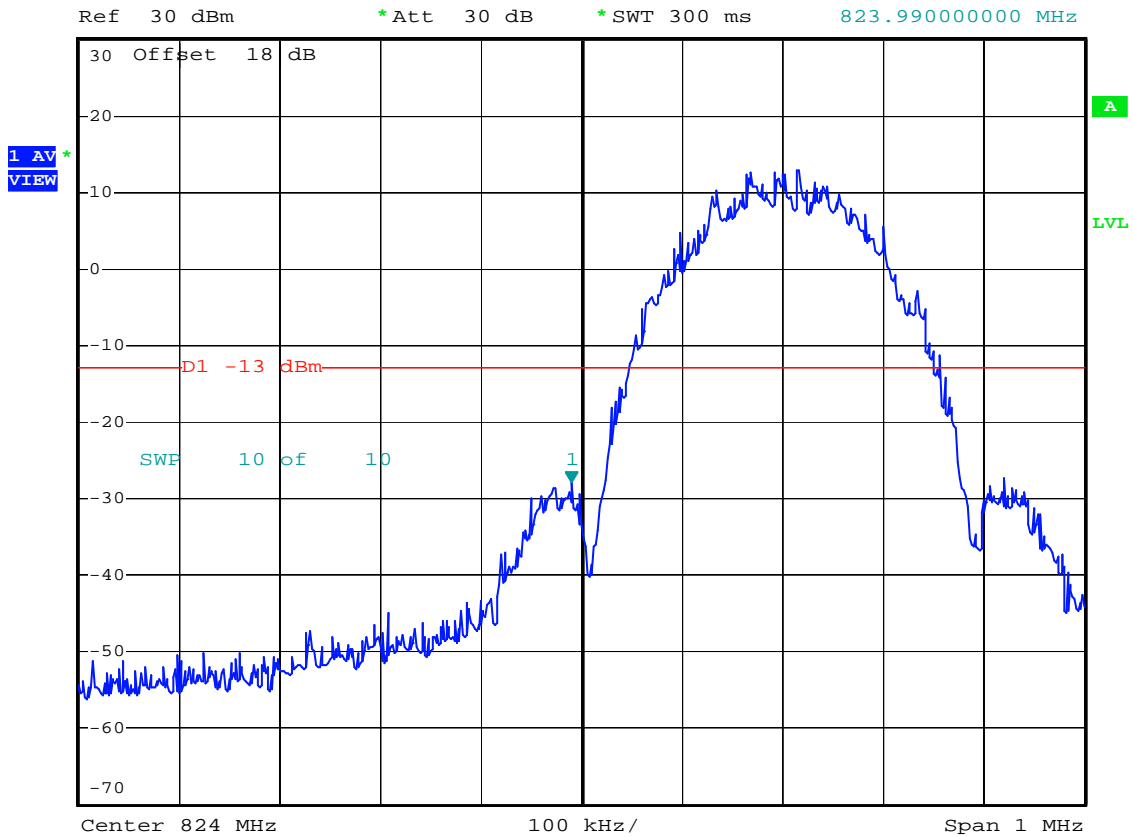

Date: 20.SEP.2007 13:15:16



- Test Mode : GSM850 (EDGE) CH128 99% Occupied Bandwidth
- Power State : High



Ref 30 dBm      \*Att 30 dB      \*RBW 3 kHz      Marker 1 [T1 ]  
 \*VBW 10 kHz      17.57 dBm  
 \*SWT 300 ms      824.20000000 MHz

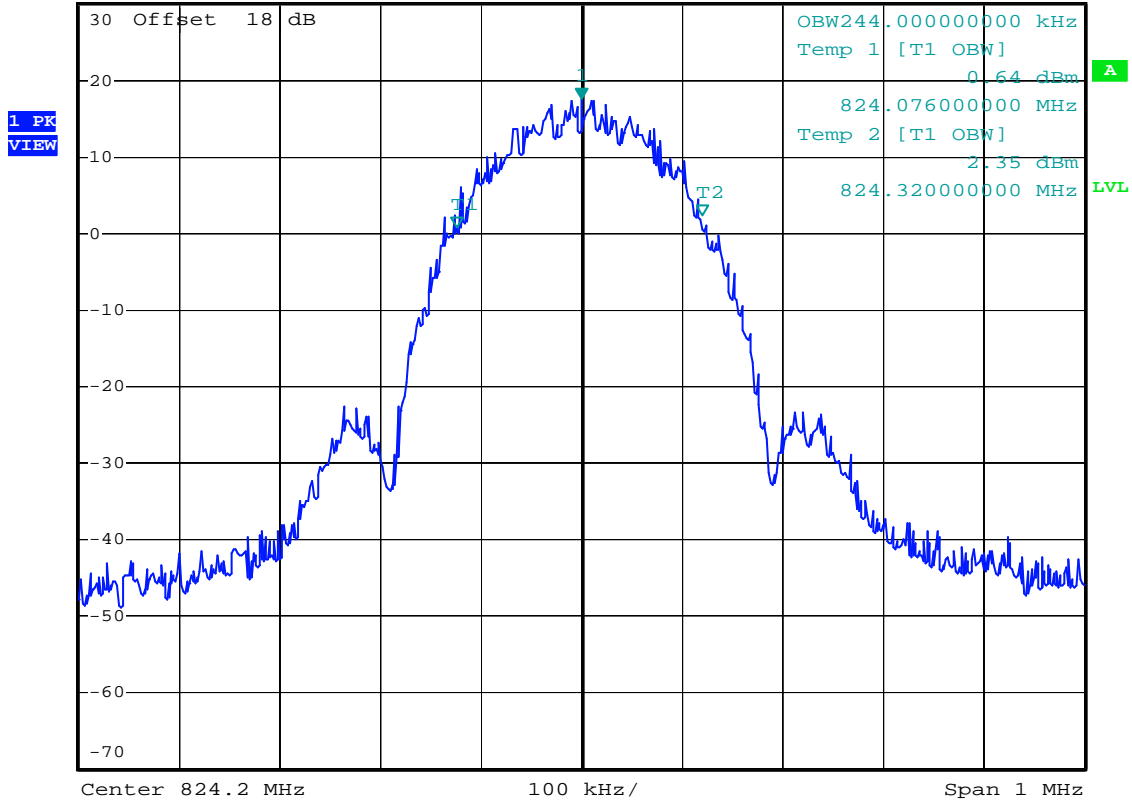

Date: 20.SEP.2007 13:01:53



- Test Mode : GSM850 (EDGE) CH189 99% Occupied Bandwidth
- Power State : High

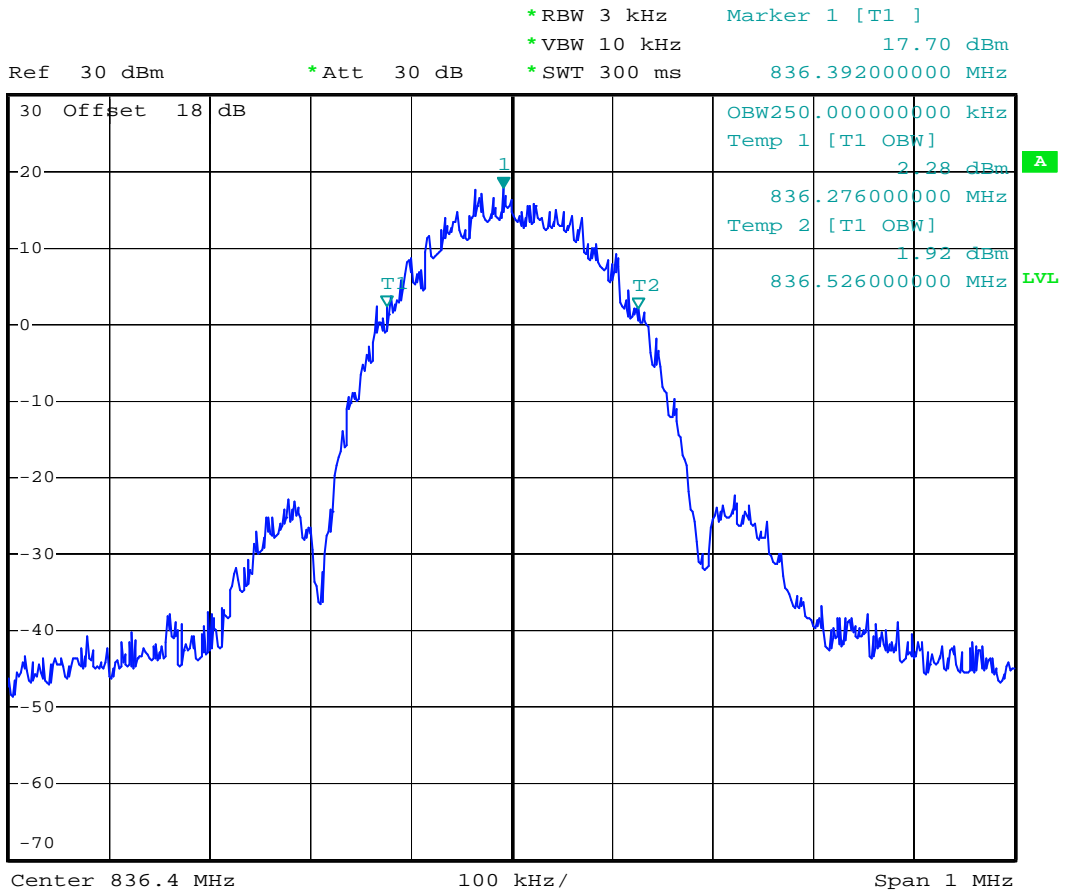

Date: 20.SEP.2007 13:03:01



\*RBW 3 kHz      Marker 1 [T1 ]  
 \*VBW 30 kHz      17.15 dBm  
 \*SWT 300 ms      836.366000000 MHz

Ref 30 dBm

\*Att 30 dB

1 PK VIEW

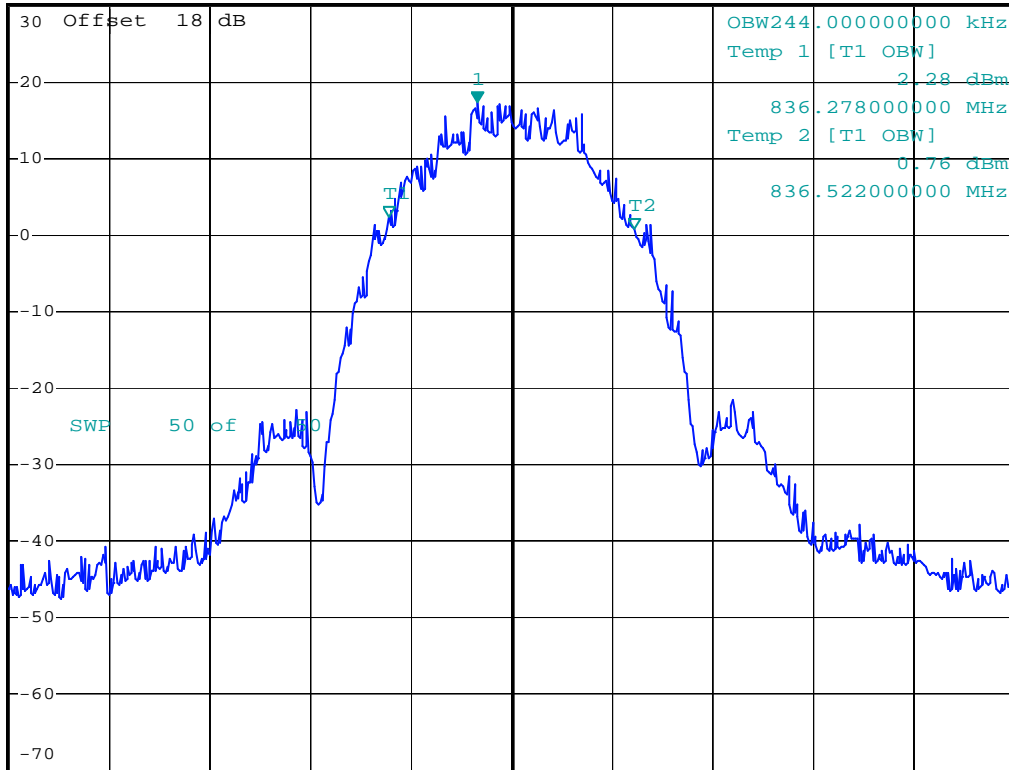

OBW244.000000000 kHz  
 Temp 1 [T1 OBW] 2.28 dBm  
 836.278000000 MHz  
 Temp 2 [T1 OBW] 0.76 dBm  
 836.522000000 MHz LVL

Center 836.4 MHz      100 kHz/      Span 1 MHz

Date: 20.SEP.2007 13:04:51





- Test Mode : GSM850 (EDGE) CH 251 99% Occupid Bandwidth
- Power State : High



Ref 30 dBm      \*Att 30 dB      \*RBW 3 kHz      Marker 1 [T1 ]  
 \*VBW 10 kHz      17.82 dBm  
 \*SWT 300 ms      848.764000000 MHz

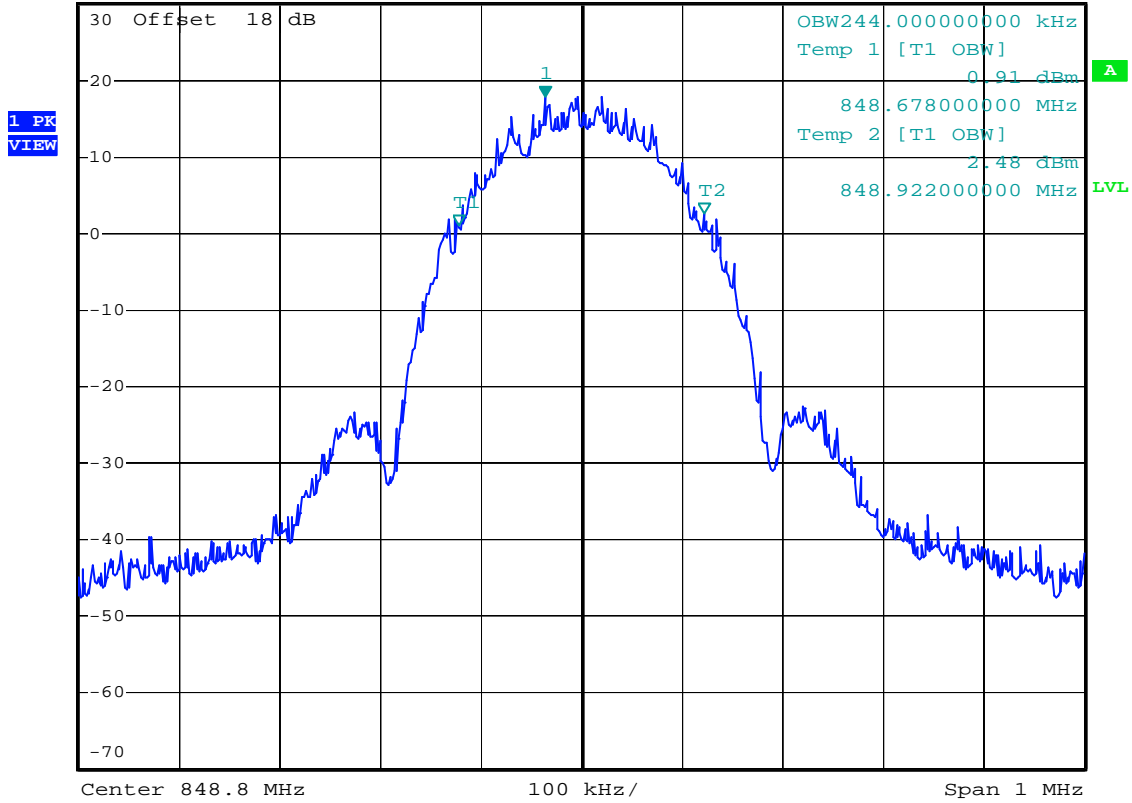

Date: 20.SEP.2007 13:00:41



- Test Mode : GSM850 (EDGE) CH128 26dB Bandwidth
- Power State : High



\*RBW 3 kHz      Delta 2 [T1 ]  
 \*VBW 10 kHz      2.94 dB  
 \*SWT 300 ms      306.00000000 kHz

Ref 30 dBm

\*Att 30 dB

1 PK  
VIEW

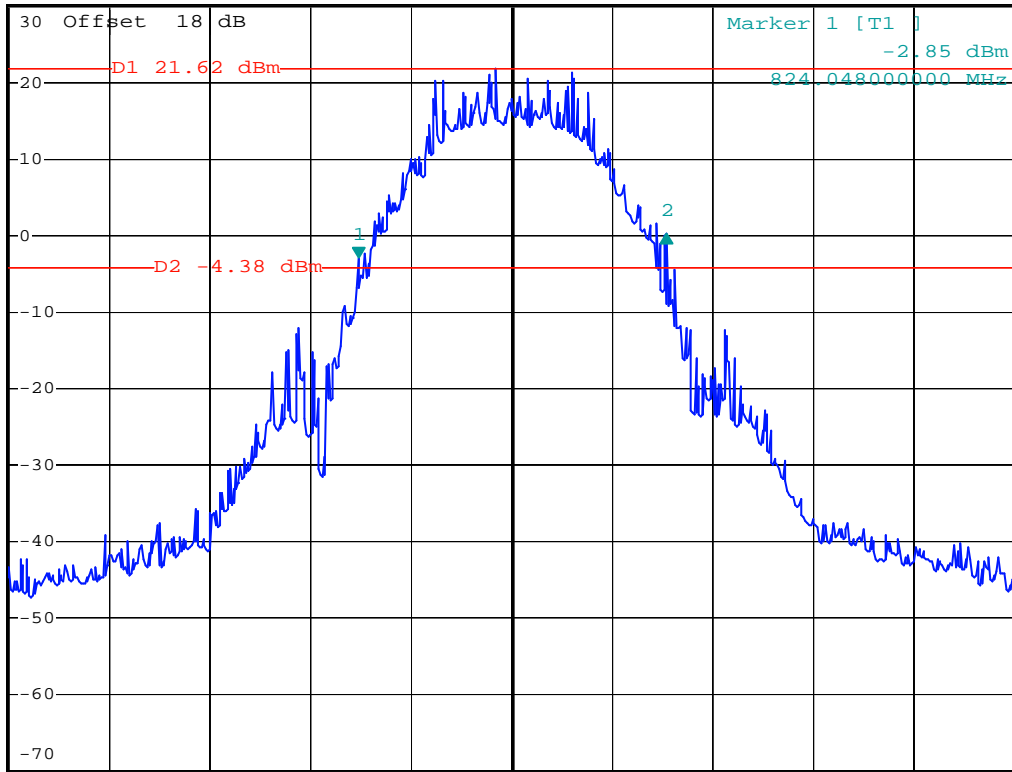

Center 824.2 MHz

100 kHz/

Span 1 MHz

Date: 20.SEP.2007 12:31:25



- Test Mode : GSM850 (EDGE) CH189 26dB Bandwidth
- Power State : High



Ref 30 dBm      \*Att 30 dB      \*RBW 3 kHz      Delta 2 [T1]      -1.05 dB  
 \*VBW 10 kHz      \*SWT 300 ms      298.00000000 kHz

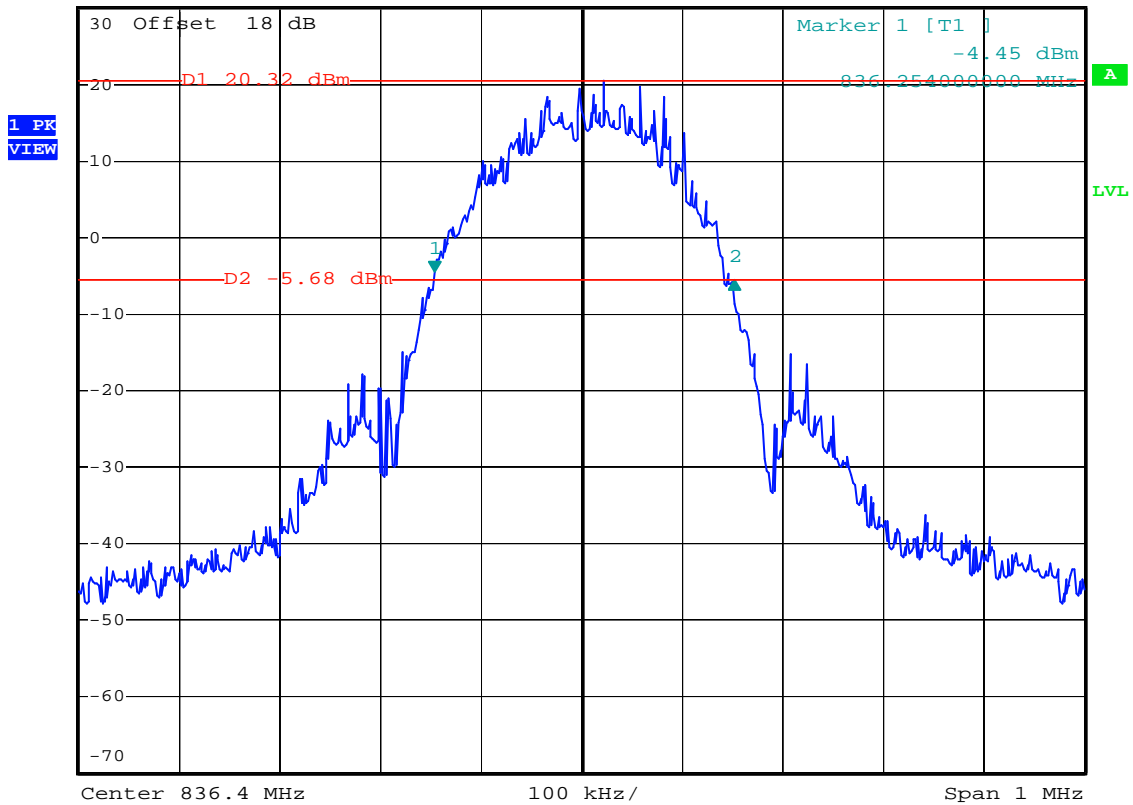

Date: 20.SEP.2007 12:35:14



- Test Mode : GSM850 (EDGE) CH 251 26dB Bandwidth
- Power State : High

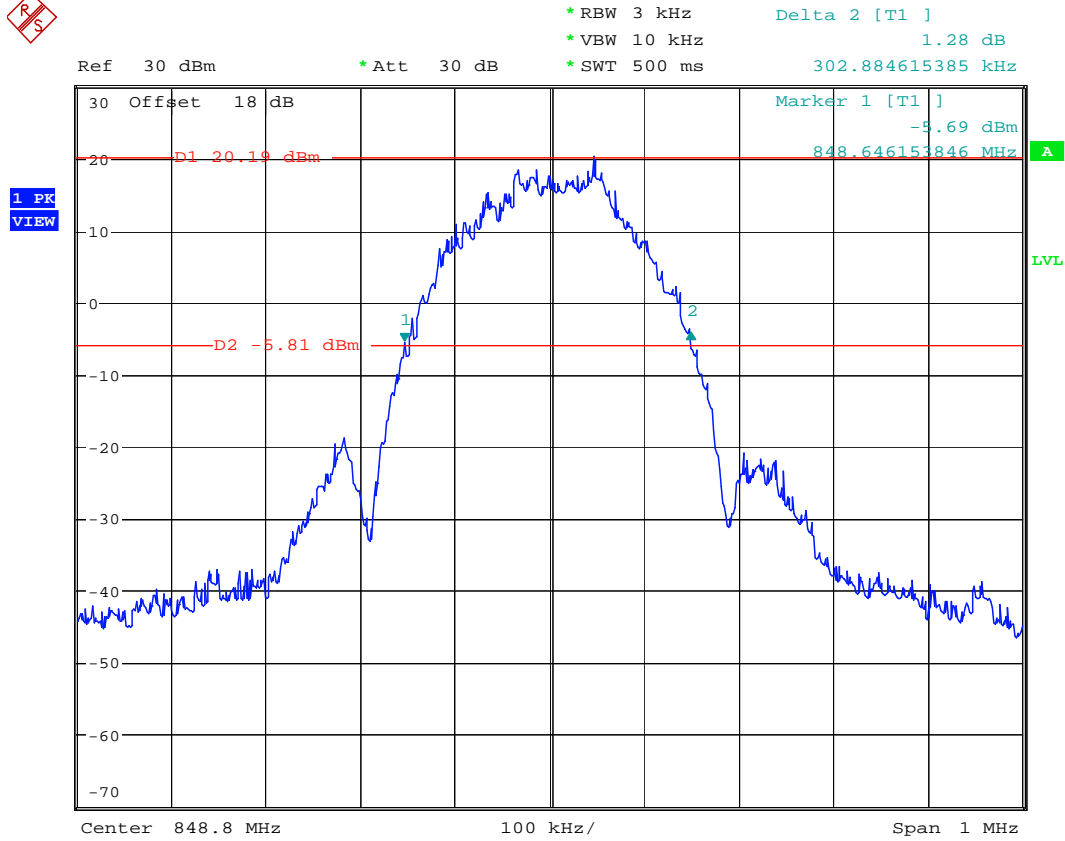

444

Date: 25.SEP.2007 18:24:26



- Test Mode : GSM850 (EDGE) CH251 Higher Band Edge
- Power State : High



\*RBW 3 kHz      Marker 1 [T1 ]  
 \*VBW 3 kHz      -26.82 dBm  
 \*SWT 300 ms      849.008000000 MHz

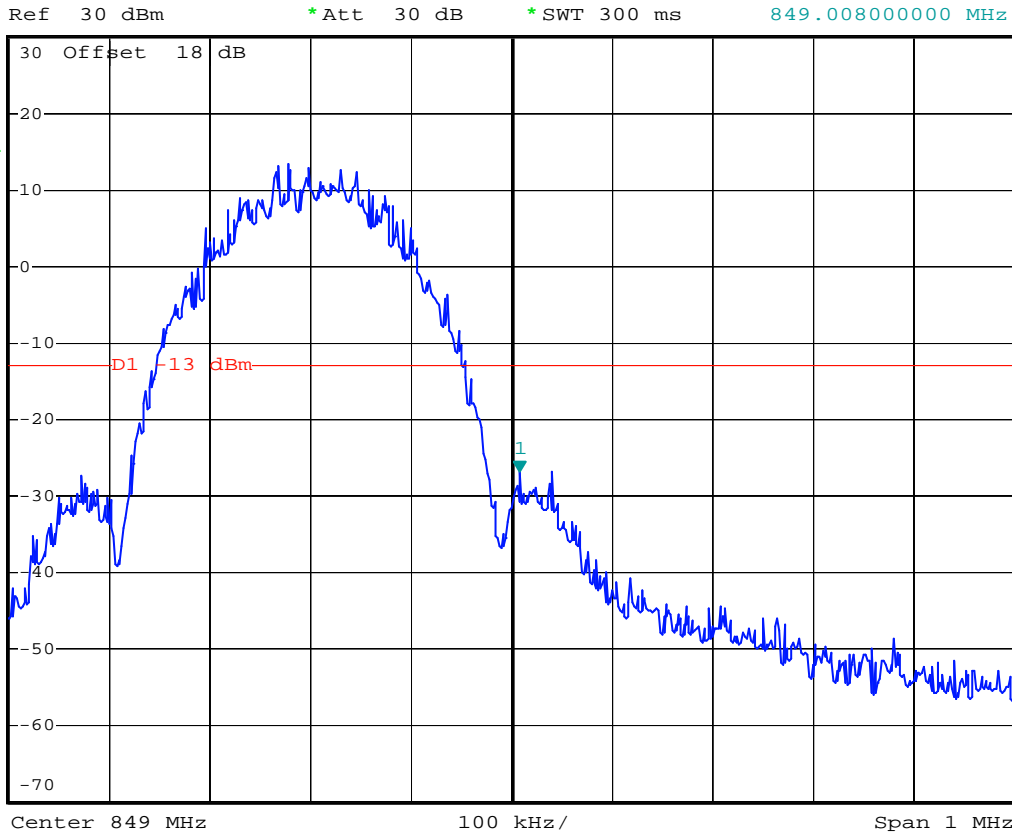

Date: 20.SEP.2007 13:19:12



\*RBW 3 kHz    Marker 1 [T1 ]  
\*VBW 10 kHz    -27.61 dBm  
\*SWT 300 ms    849.004000000 MHz

Ref 30 dBm

\*Att 30 dB

1 AV \*  
VIEW

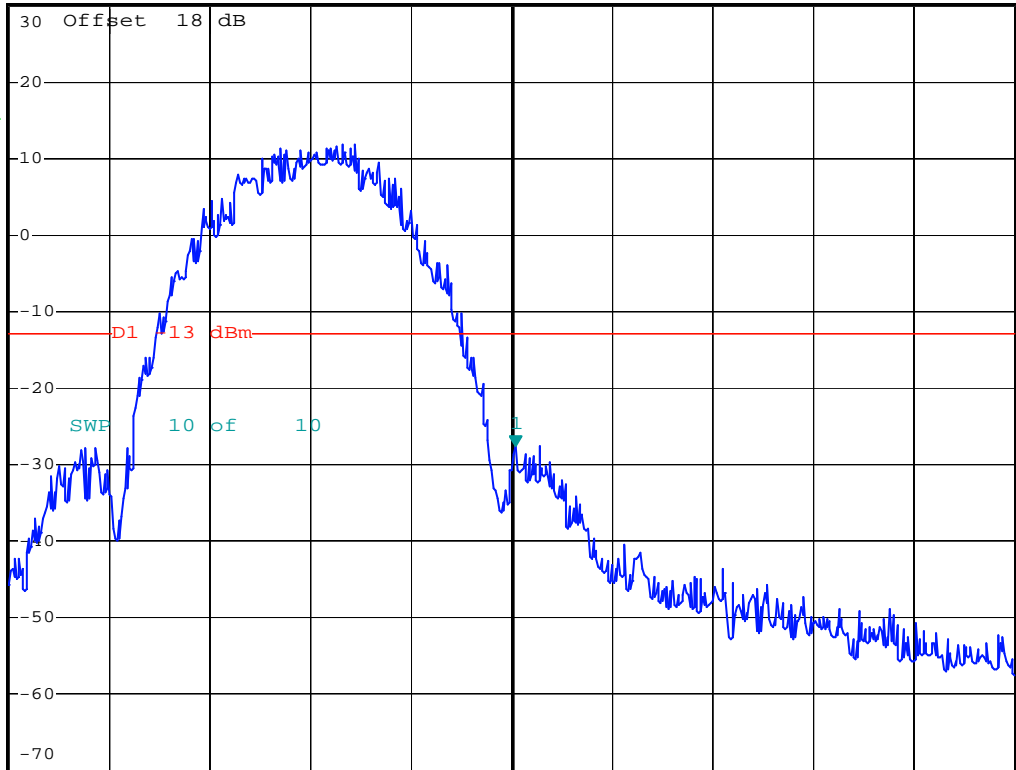

Center 849 MHz

100 kHz/

Span 1 MHz

Date: 20.SEP.2007 13:17:40



- Mode 3
- Test Mode : PCS1900 (GSM) CH512 Lower Band Edge
- Power State : High



Ref 30 dBm      \*Att 30 dB      \*RBW 3 kHz      Marker 1 [T1 ]  
\*VBW 3 kHz      -19.88 dBm  
\*SWT 300 ms      1.849996000 GHz

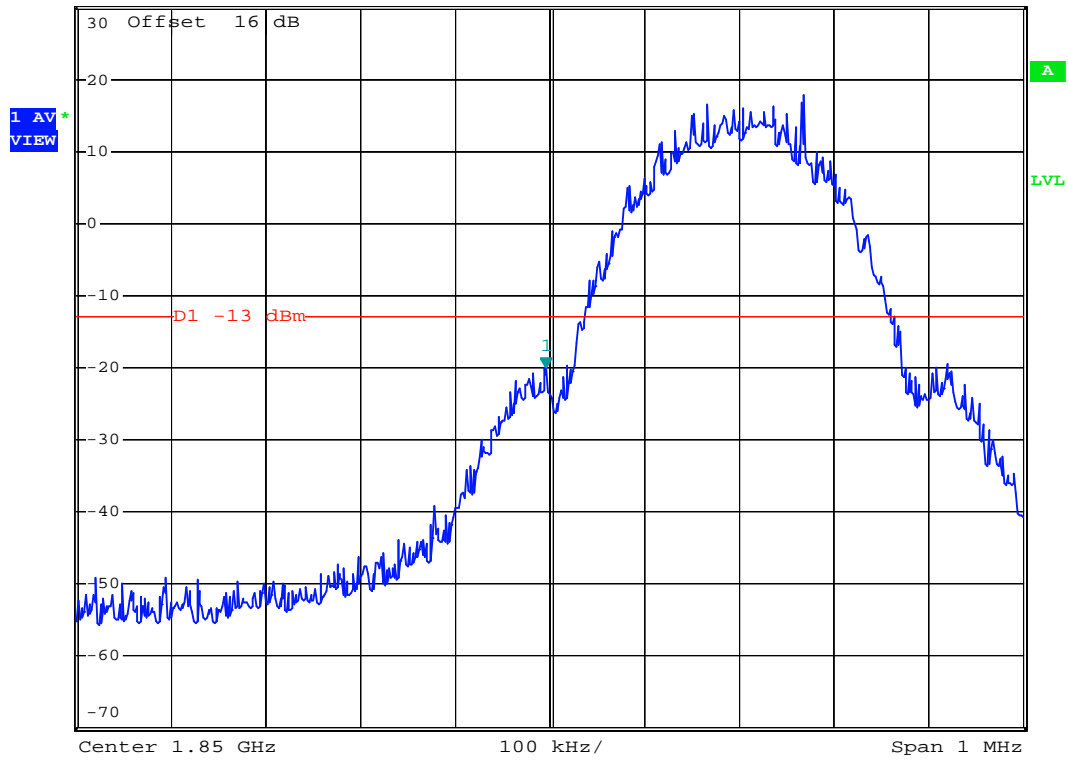

Date: 11.SEP.2007 17:22:42



Ref 30 dBm      \*Att 30 dB      \*RBW 3 kHz      Marker 1 [T1 ]  
\*VBW 10 kHz      -18.38 dBm  
\*SWT 300 ms      1.849994000 GHz

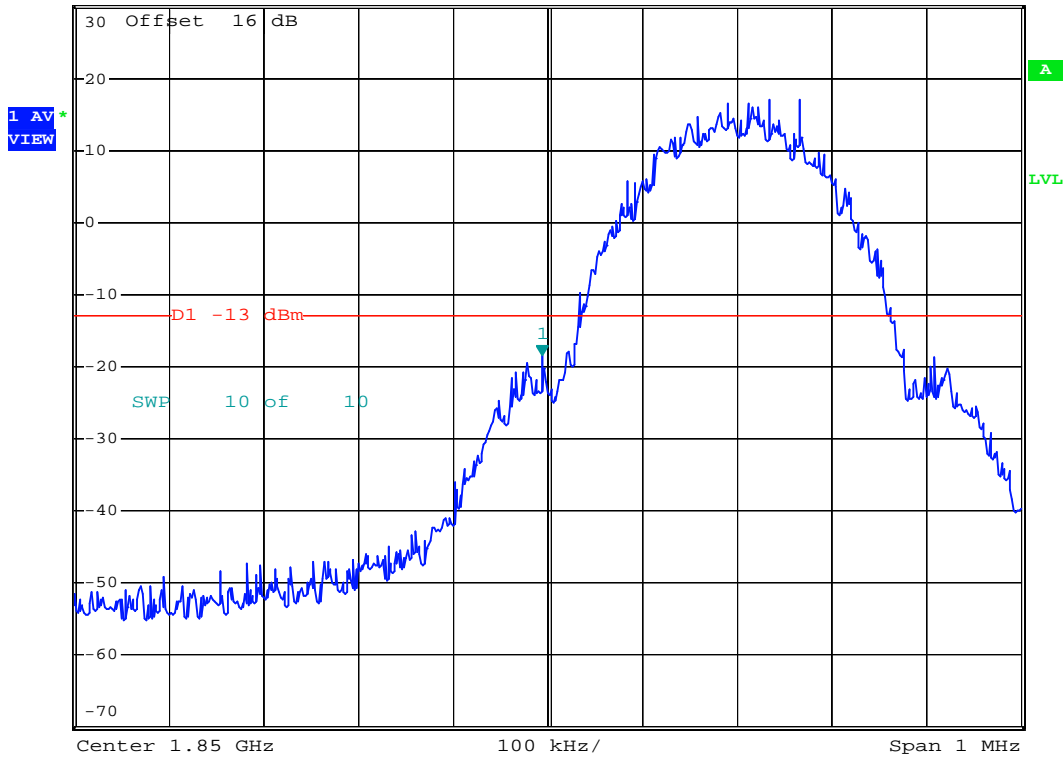

Date: 11.SEP.2007 17:27:02





- Test Mode : PCS1900 (GSM) CH512 99% Occupied Bandwidth
- Power State : High



\*RBW 3 kHz      Marker 1 [T1 ]  
 \*VBW 10 kHz      21.16 dBm  
 \*SWT 300 ms      1.850184000 GHz

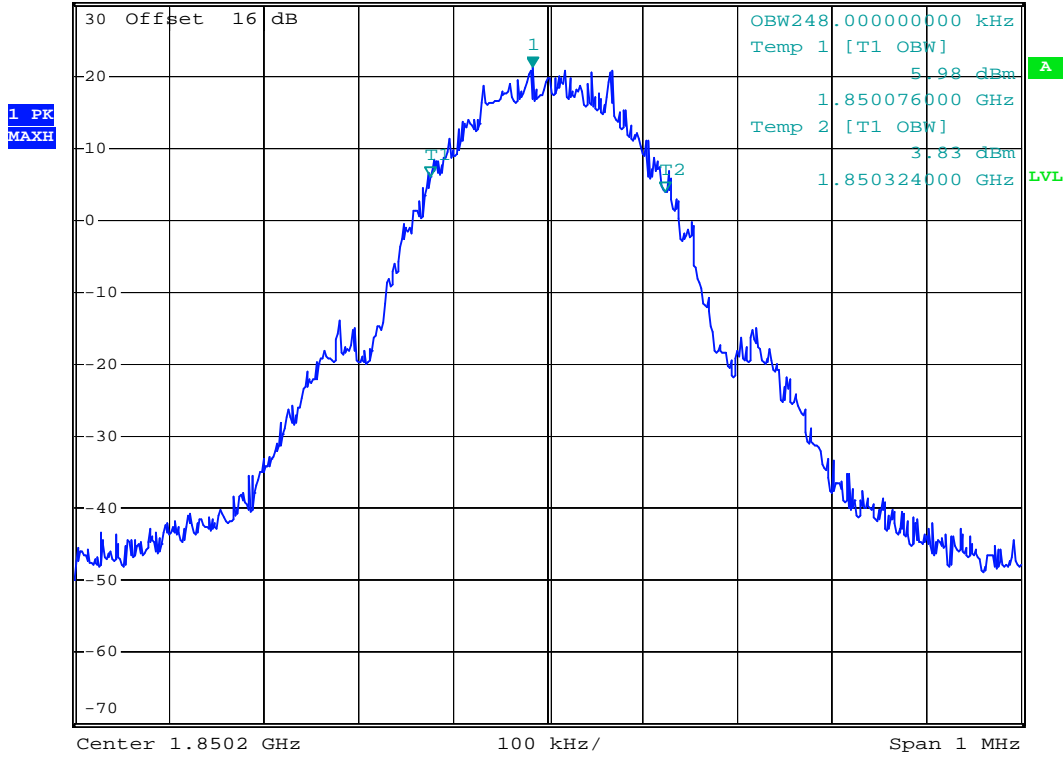

Date: 11.SEP.2007 17:18:29



- Test Mode : PCS1900 (GSM) CH661 99% Occupied Bandwidth
- Power State : High

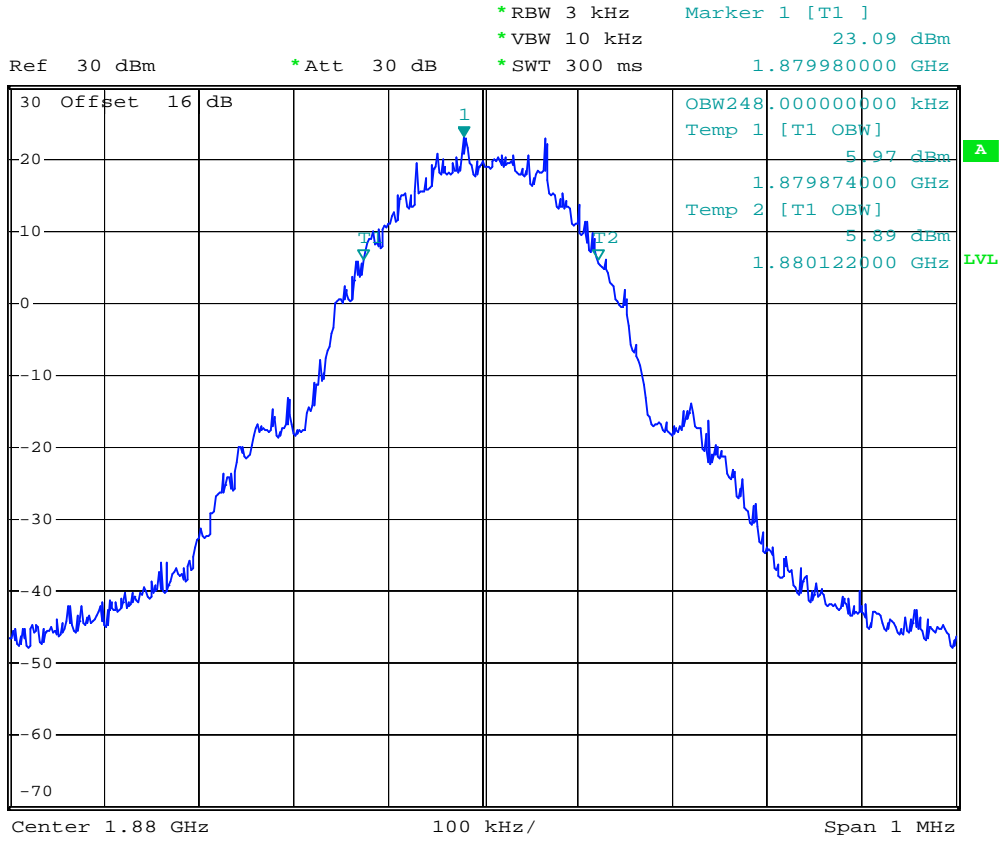

Date: 11.SEP.2007 17:17:30



\*RBW 3 kHz      Marker 1 [T1 ]  
 \*VBW 30 kHz      20.87 dBm  
 \*SWT 300 ms      1.879980000 GHz

Ref 30 dBm

\*Att 30 dB

1 PK  
MAXH

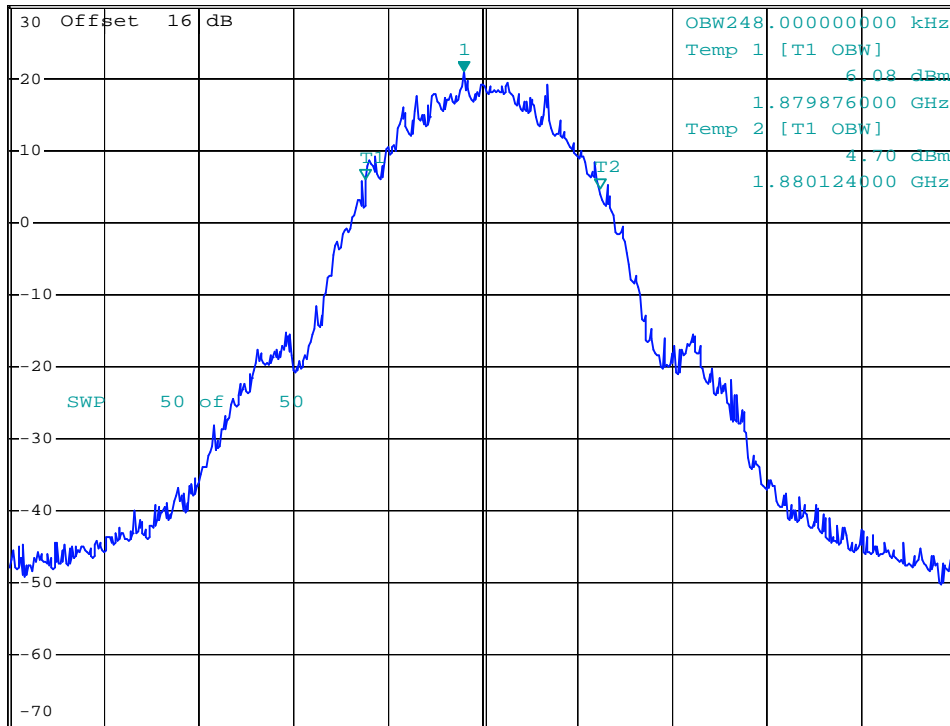

Center 1.88 GHz

100 kHz/

Span 1 MHz

Date: 11.SEP.2007 17:20:37



- Test Mode : PCS1900 (GSM) CH810 99% Occupied Bandwidth
- Power State : High

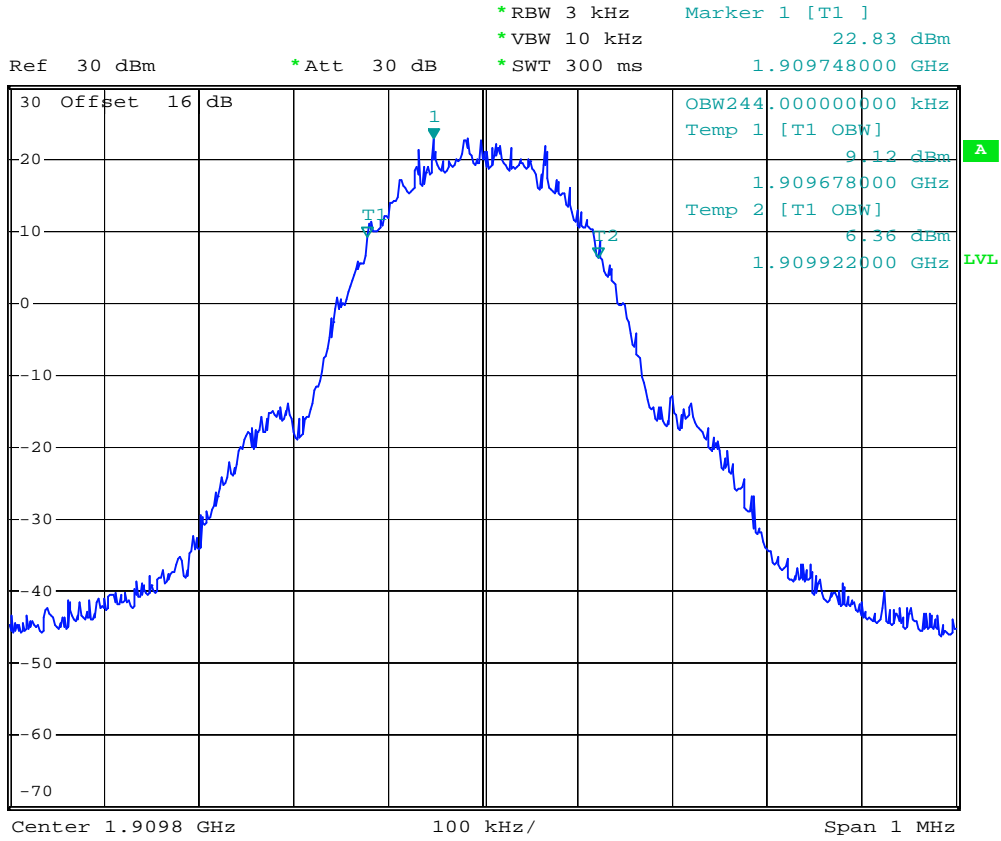

Date: 11.SEP.2007 17:16:31



- Test Mode : PCS1900 (GSM) CH512 26dB Bandwidth
- Power State : High

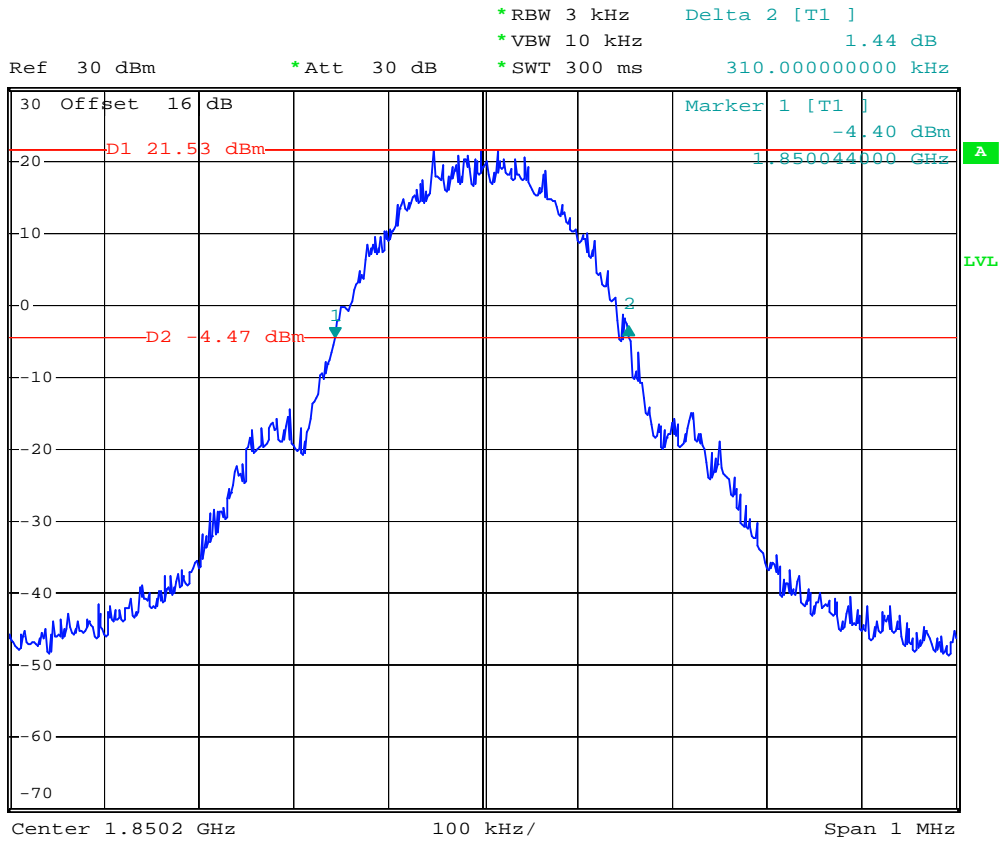

Date: 11.SEP.2007 17:10:50



- Test Mode : PCS1900 (GSM) CH661 26dB Bandwidth
- Power State : High



\*RBW 3 kHz      Delta 2 [T1 ]  
 \*VBW 10 kHz      -0.80 dB  
 \*SWT 300 ms      312.00000000 kHz

Ref 30 dBm

\*Att 30 dB

1 PK  
VIEW

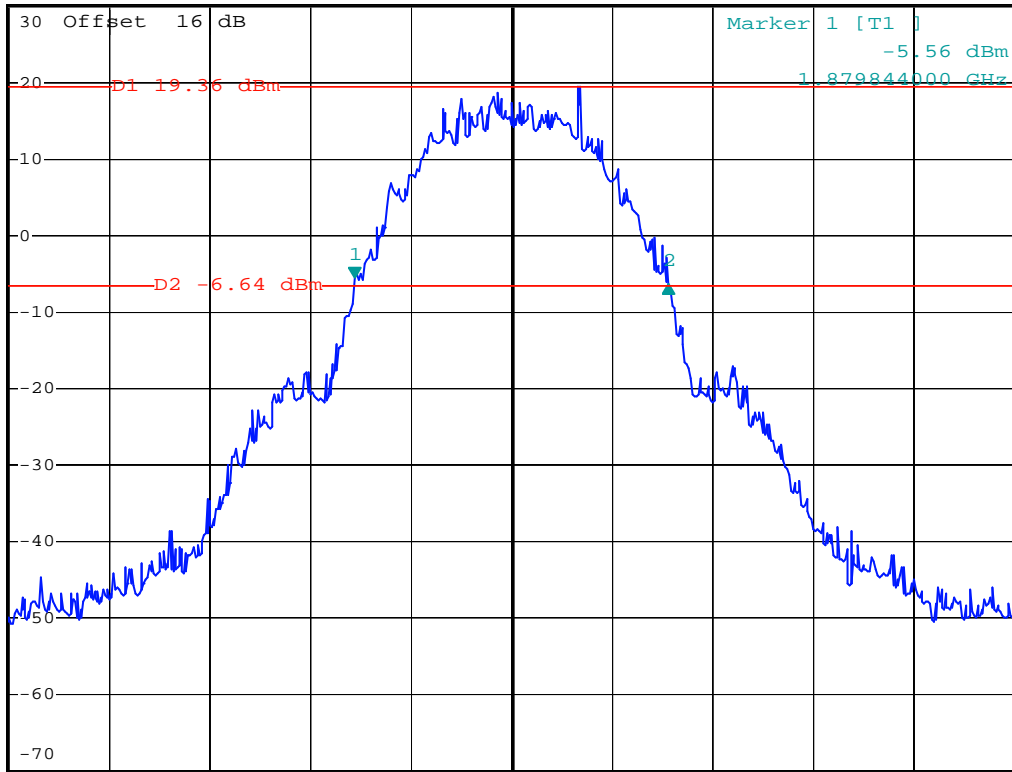

Center 1.88 GHz

100 kHz/

Span 1 MHz

Date: 20.SEP.2007 16:36:43



- Test Mode : PCS1900 (GSM) CH810 26dB Bandwidth
- Power State : High



\*RBW 3 kHz      Delta 2 [T1 ]  
 \*VBW 10 kHz      1.17 dB  
 \*SWT 300 ms      308.00000000 kHz

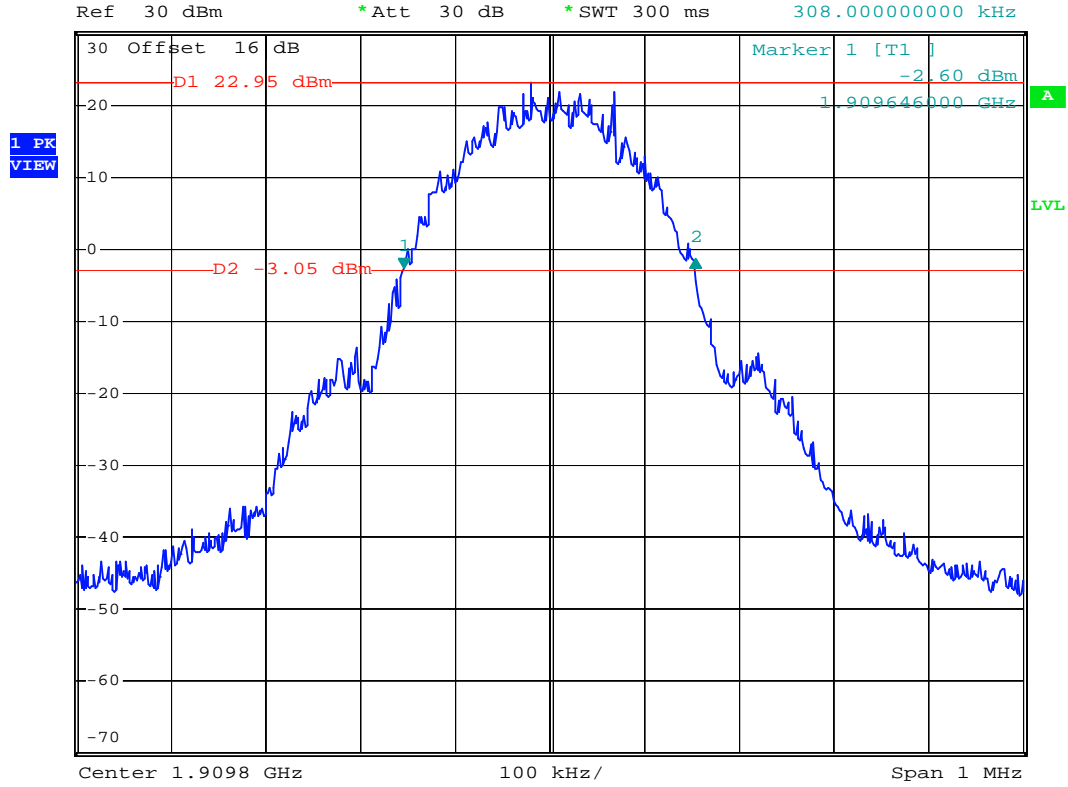

Date: 11.SEP.2007 17:14:38



- Test Mode : PCS1900 (GSM) CH810 Higher Band Edge
- Power State : High



\*RBW 3 kHz      Marker 1 [T1 ]  
\*VBW 3 kHz      -17.85 dBm  
\*SWT 300 ms      1.910020000 GHz

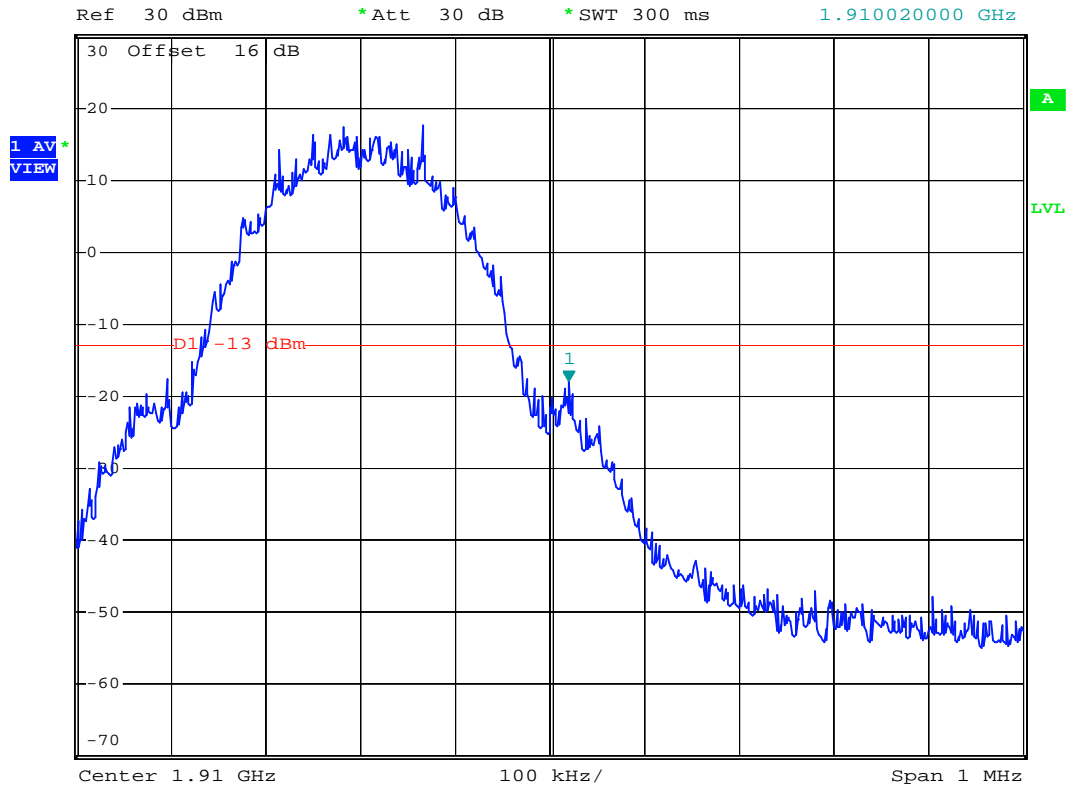

Date: 11.SEP.2007 17:24:05





Ref 30 dBm      \*Att 30 dB      \*RBW 3 kHz      Marker 1 [T1 ]  
\*VBW 10 kHz      -19.89 dBm  
\*SWT 300 ms      1.910018000 GHz

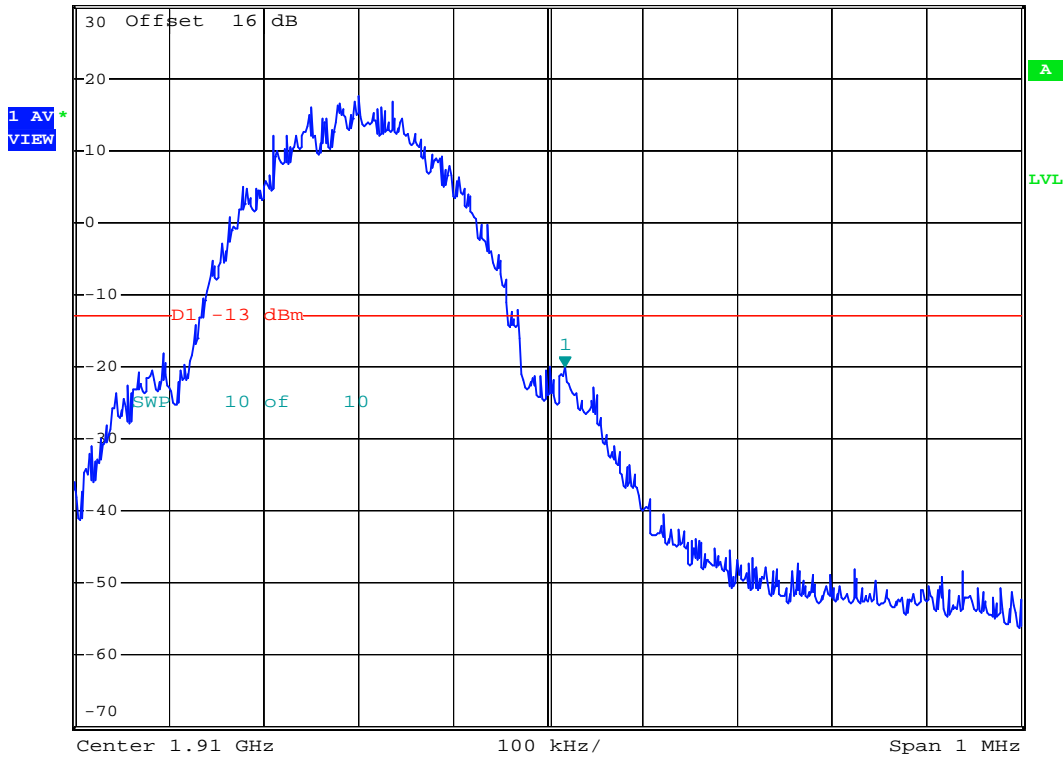

Date: 11.SEP.2007 17:25:24



- Mode 4
- Test Mode : PCS1900 (EDGE) CH512 Lower Band Edge
- Power State : High

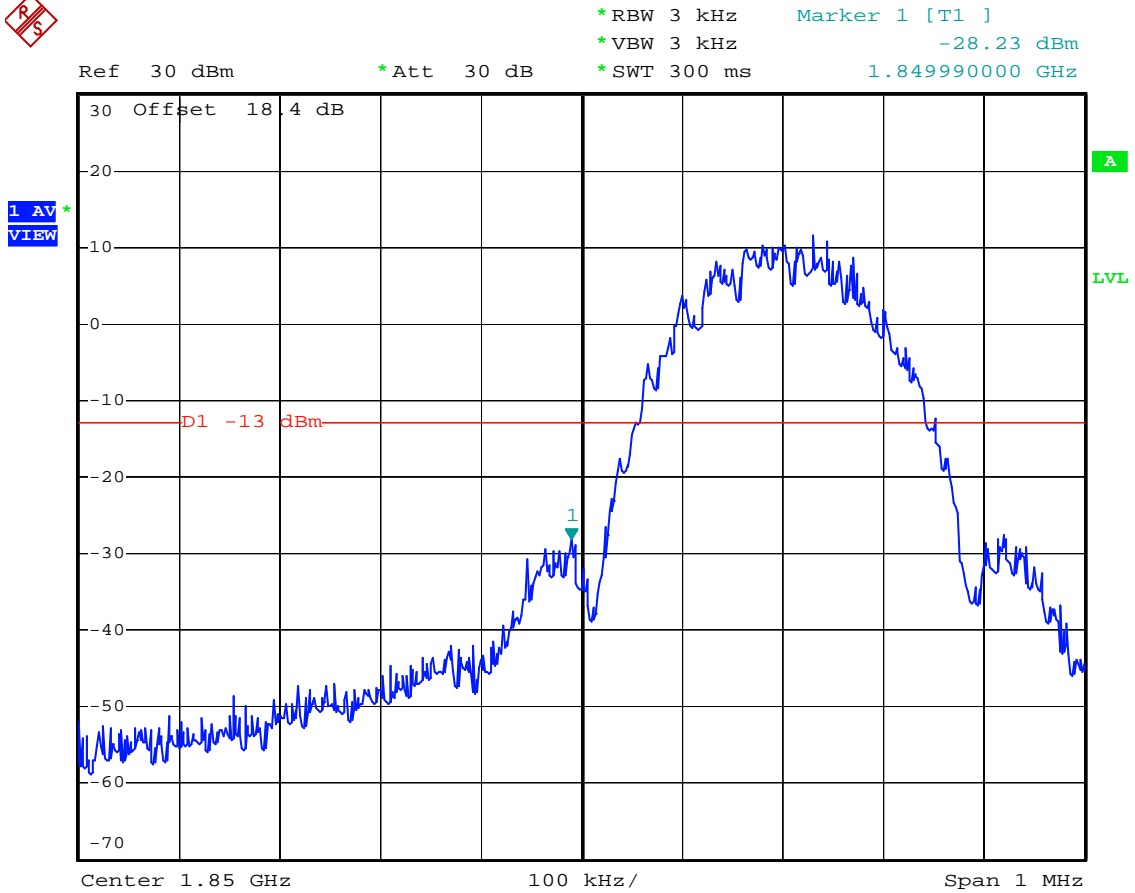

Date: 20.SEP.2007 14:38:27



\*RBW 3 kHz    Marker 1 [T1 ]  
\*VBW 10 kHz    -27.49 dBm  
\*SWT 300 ms    1.849982000 GHz

Ref 30 dBm

\*Att 30 dB

1 AV \*  
VIEW

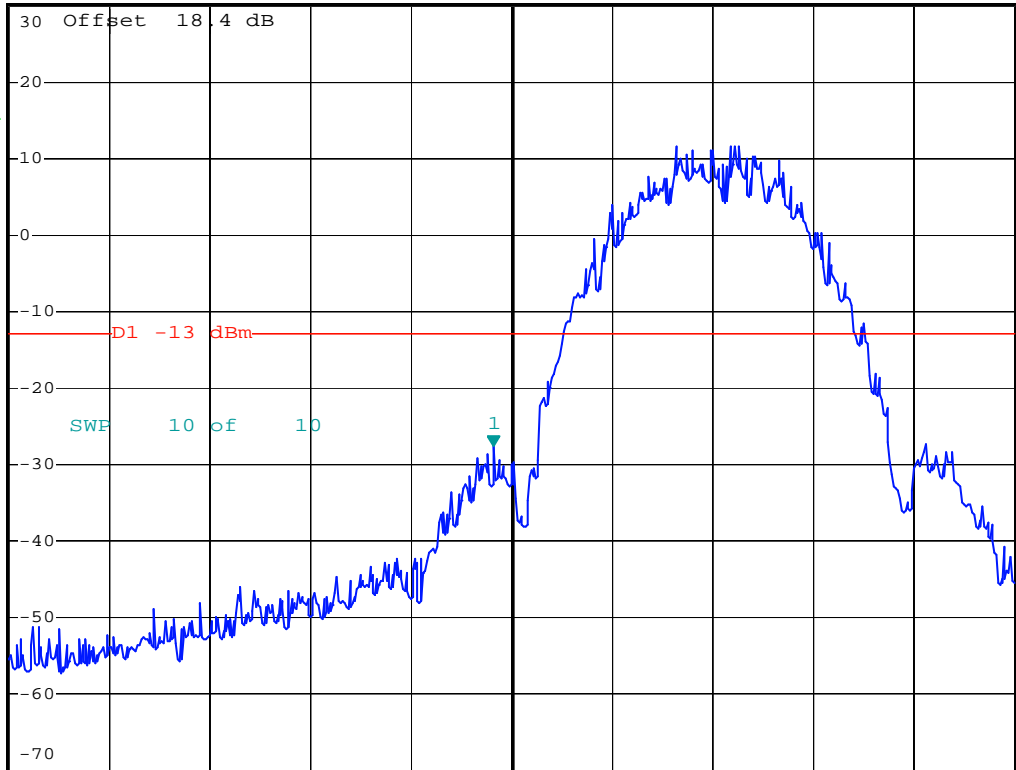

Center 1.85 GHz

100 kHz/

Span 1 MHz

Date: 20.SEP.2007 14:36:53



- Test Mode : PCS1900 (EDGE) CH512 99% Occupied Bandwidth
- Power State : High

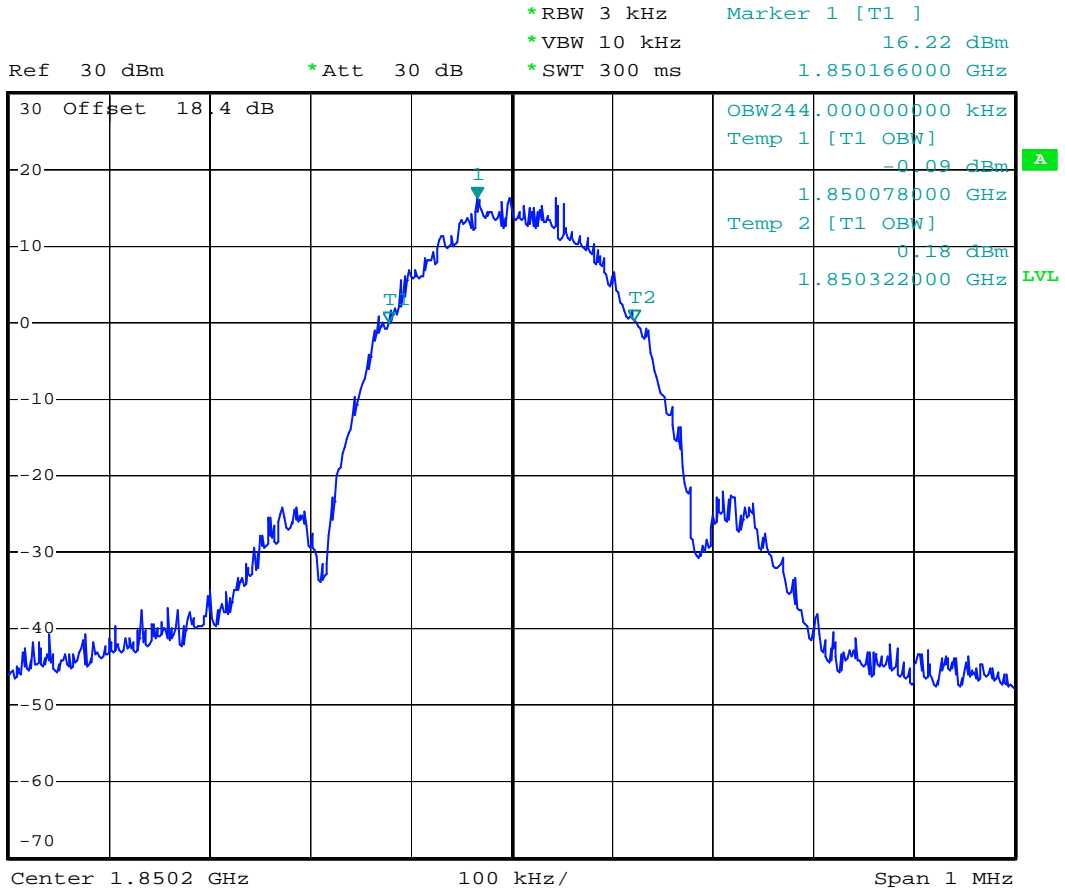

Date: 20.SEP.2007 14:20:26



- Test Mode : PCS1900 (EDGE) CH661 99% Occupied Bandwidth
- Power State : High

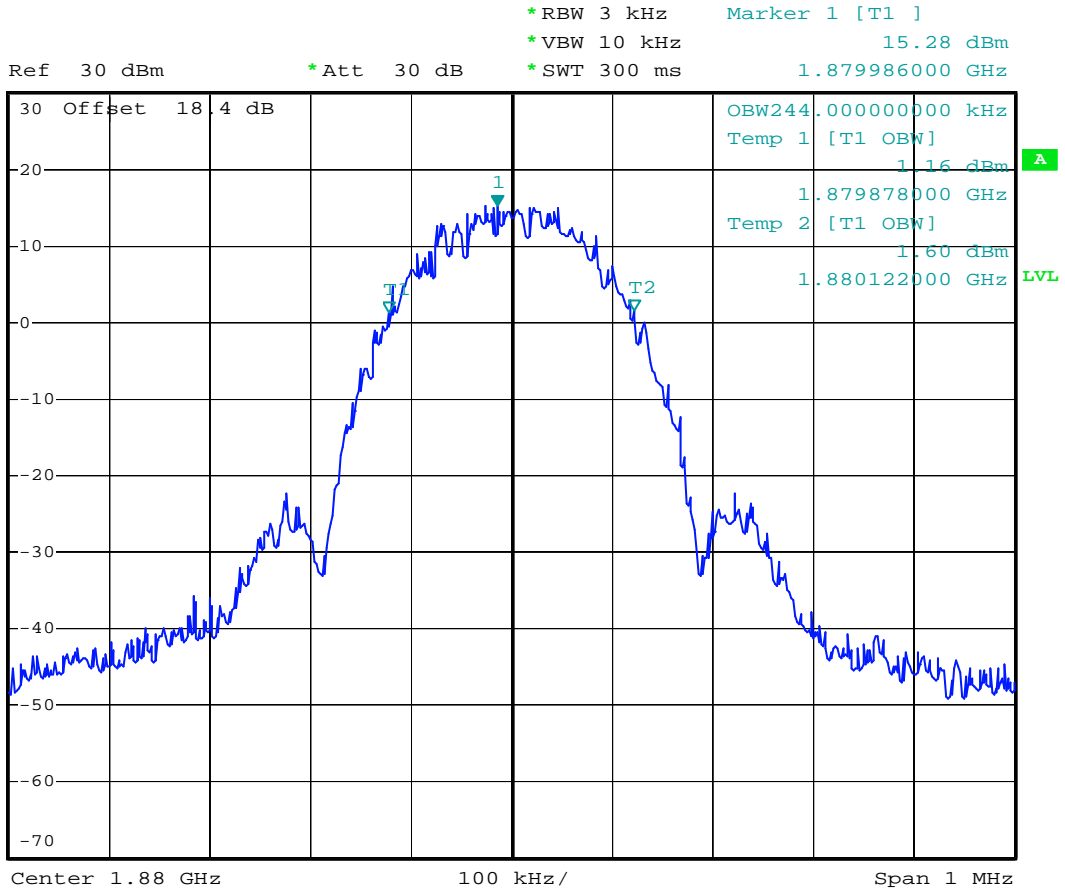

Date: 20.SEP.2007 14:21:30



\*RBW 3 kHz Marker 1 [T1 ] 16.01 dBm  
\*VBW 30 kHz 1.879970000 GHz  
\*SWT 300 ms

Ref 30 dBm \*Att 30 dB

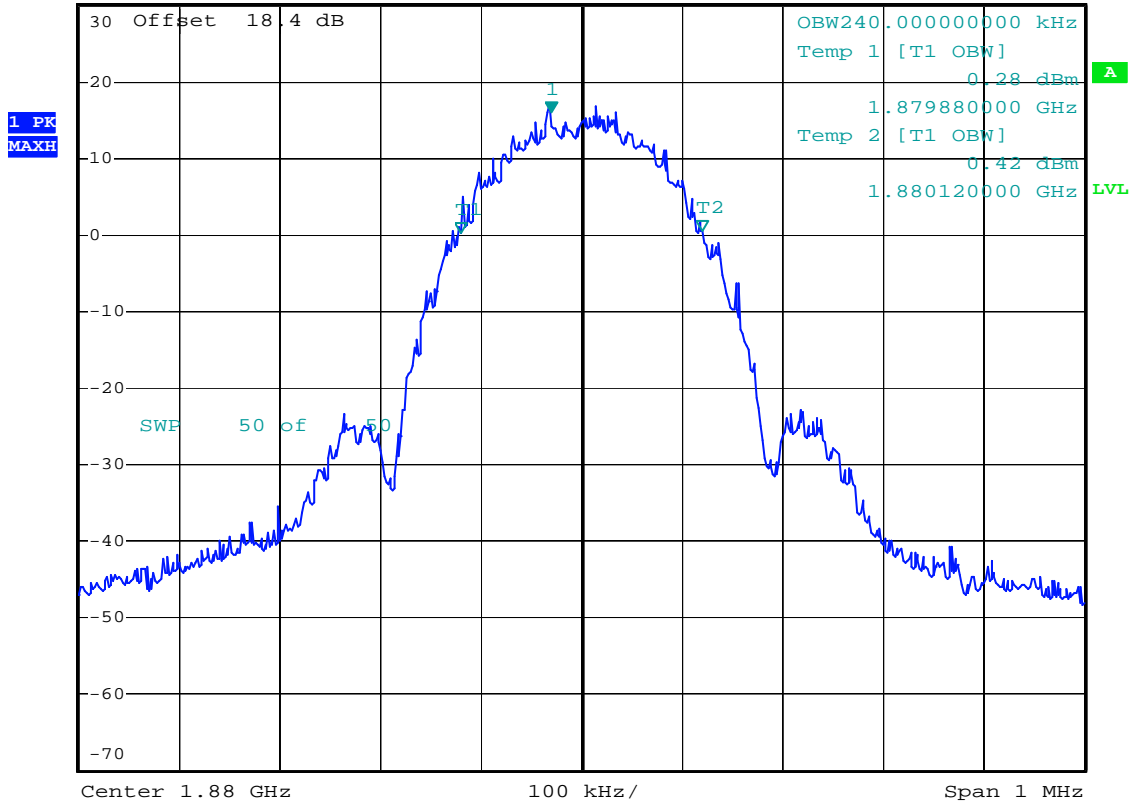

Date: 20.SEP.2007 14:24:30



- Test Mode : PCS1900 (EDGE) CH810 99% Occupied Bandwidth
- Power State : High



Ref 30 dBm      \*Att 30 dB      \*RBW 3 kHz      Marker 1 [T1 ]      15.88 dBm  
 \*VBW 10 kHz      1.909768000 GHz  
 \*SWT 300 ms

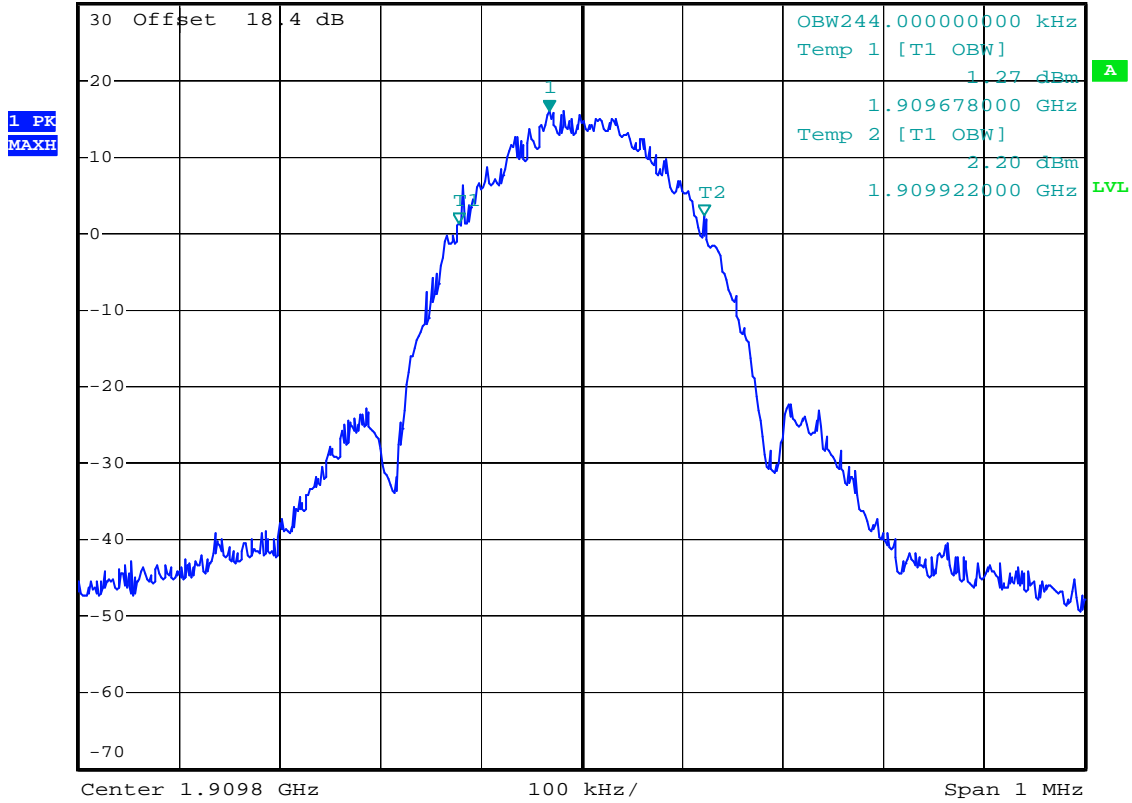

Date: 20.SEP.2007 14:19:31



- Test Mode : PCS1900 (EDGE) CH512 26dB Bandwidth
- Power State : High



\*RBW 3 kHz      Delta 2 [T1 ]  
 \*VBW 10 kHz      -0.11 dB  
 \*SWT 300 ms      308.00000000 kHz

Ref 30 dBm

\*Att 30 dB

1 PK  
VIEW

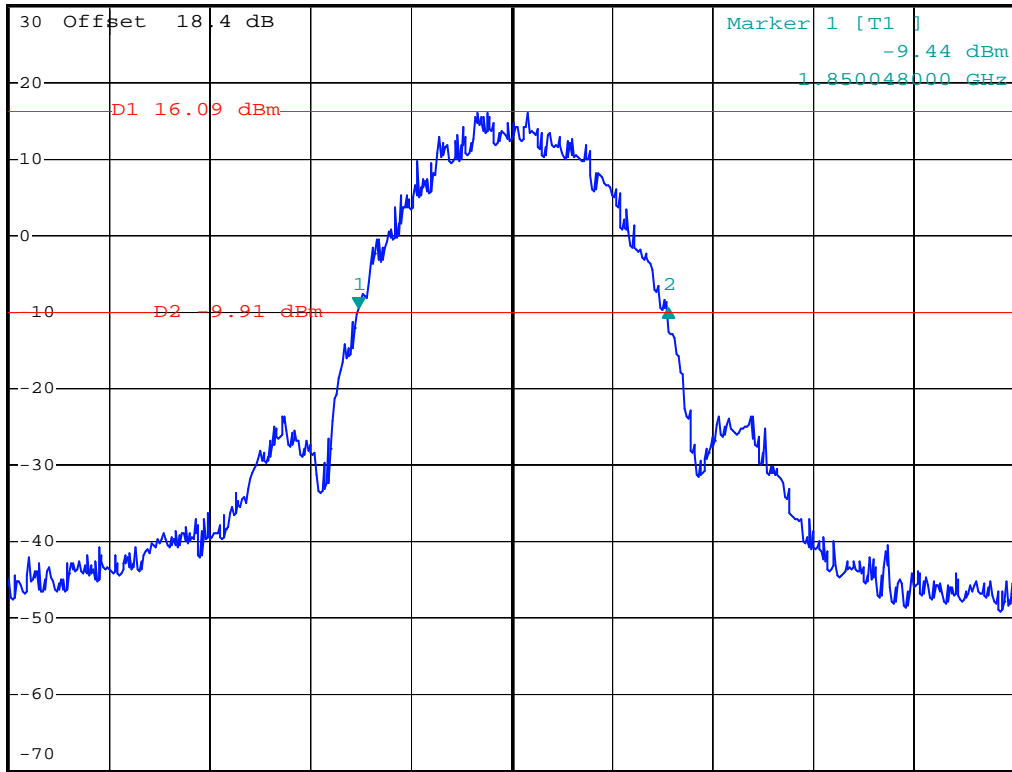

Center 1.8502 GHz

100 kHz/

Span 1 MHz

Date: 20.SEP.2007 14:45:41





- Test Mode : PCS1900 (EDGE) CH661 26dB Bandwidth
- Power State : High



\*RBW 3 kHz      Delta 2 [T1 ]  
 \*VBW 10 kHz      0.46 dB  
 \*SWT 300 ms      308.00000000 kHz

Ref 30 dBm

\*Att 30 dB

1 PK  
VIEW

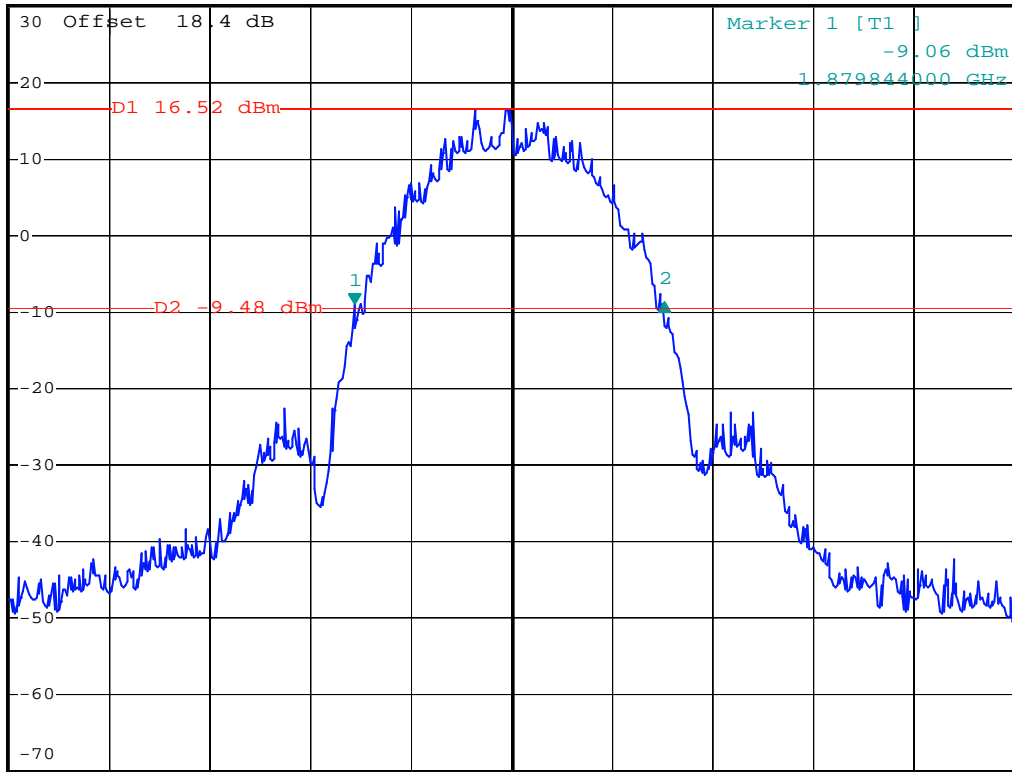

Center 1.88 GHz

100 kHz/

Span 1 MHz

Date: 20.SEP.2007 14:47:24



- Test Mode : PCS1900 (EDGE) CH810 26dB Bandwidth
- Power State : High



Ref 30 dBm      \*Att 30 dB      \*RBW 3 kHz      Delta 2 [T1 ]      \*VBW 10 kHz      1.39 dB      \*SWT 300 ms      304.00000000 kHz

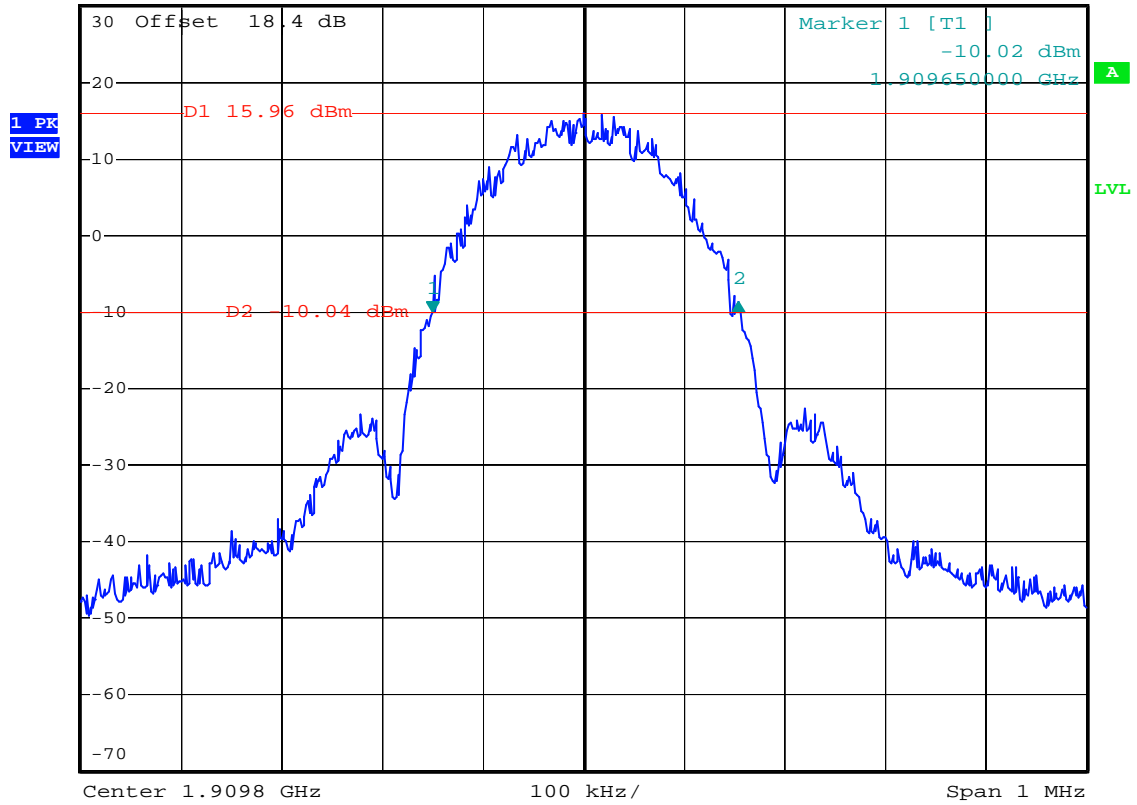

Date: 20.SEP.2007 14:49:04



- Test Mode : PCS1900(EDGE) CH810 Higher Band Edge
- Power State : High



\*RBW 3 kHz      Marker 1 [T1 ]  
 \*VBW 3 kHz      -27.81 dBm  
 \*SWT 300 ms      1.910032000 GHz

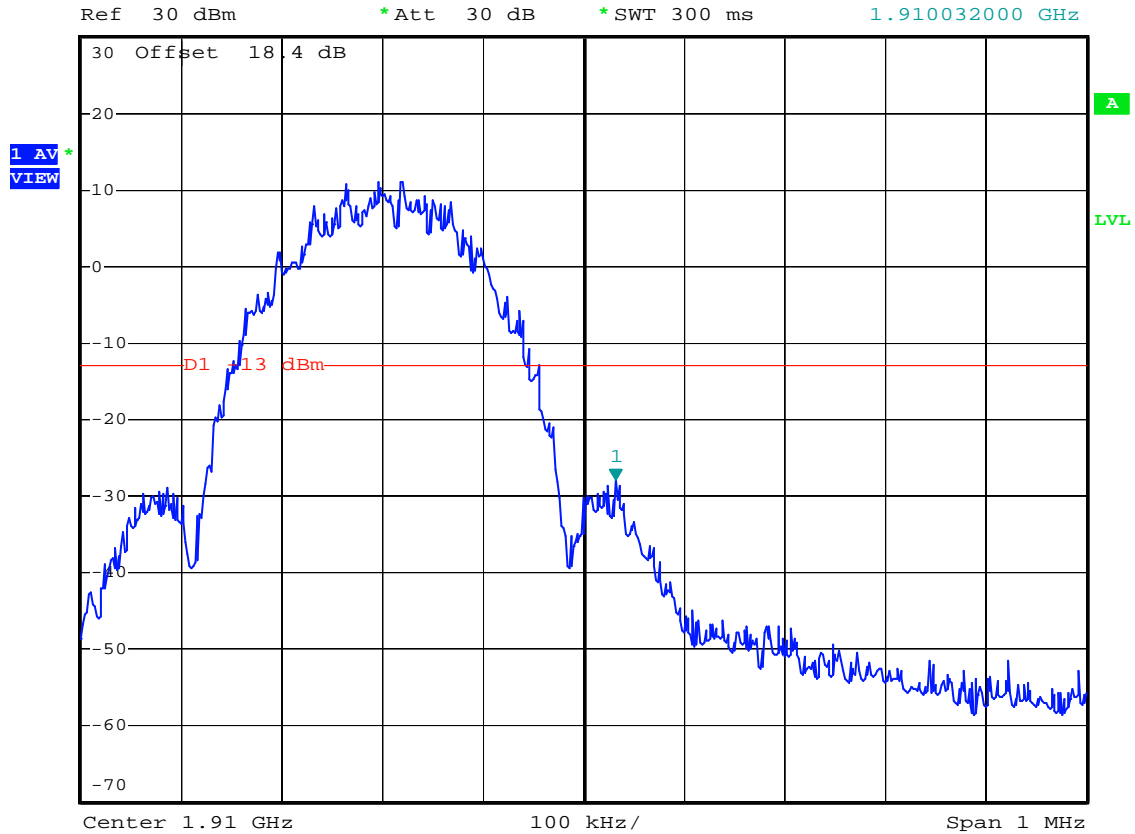

Date: 20.SEP.2007 14:32:58



\*RBW 3 kHz    Marker 1 [T1 ]  
\*VBW 10 kHz    -28.64 dBm  
\*SWT 300 ms    1.910004000 GHz

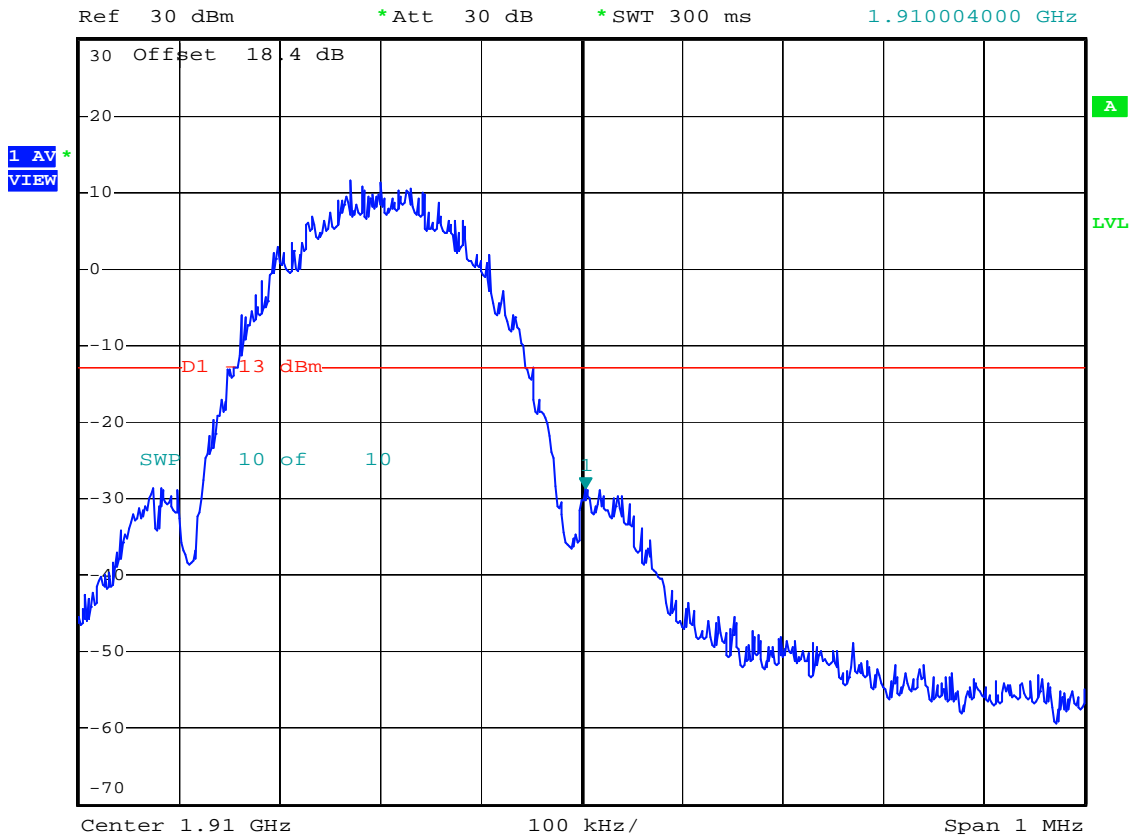

Date: 20.SEP.2007 14:34:36

## 4.5 Conducted Emission

### 4.5.1 Measurement Instruments

As described in chapter 5 of this test report.

### 4.5.2 Test Procedure

1. The EUT was connected to Spectrum Analyzer and Base Station via power divider.
2. The middle channel for the highest RF power within the transmitting frequency was measured.
3. The conducted spurious emission for the whole frequency range was taken.

### 4.5.3 Test Setup Layout

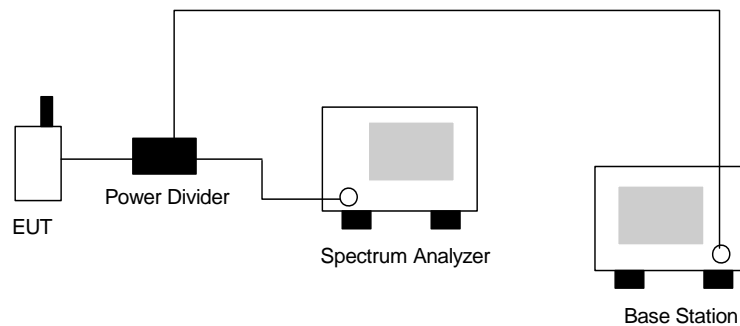



4.5.4 Test Result

- Mode 1
- Test Mode : GSM850 (GSM) CH189
- Frequency Range : 30M-1G

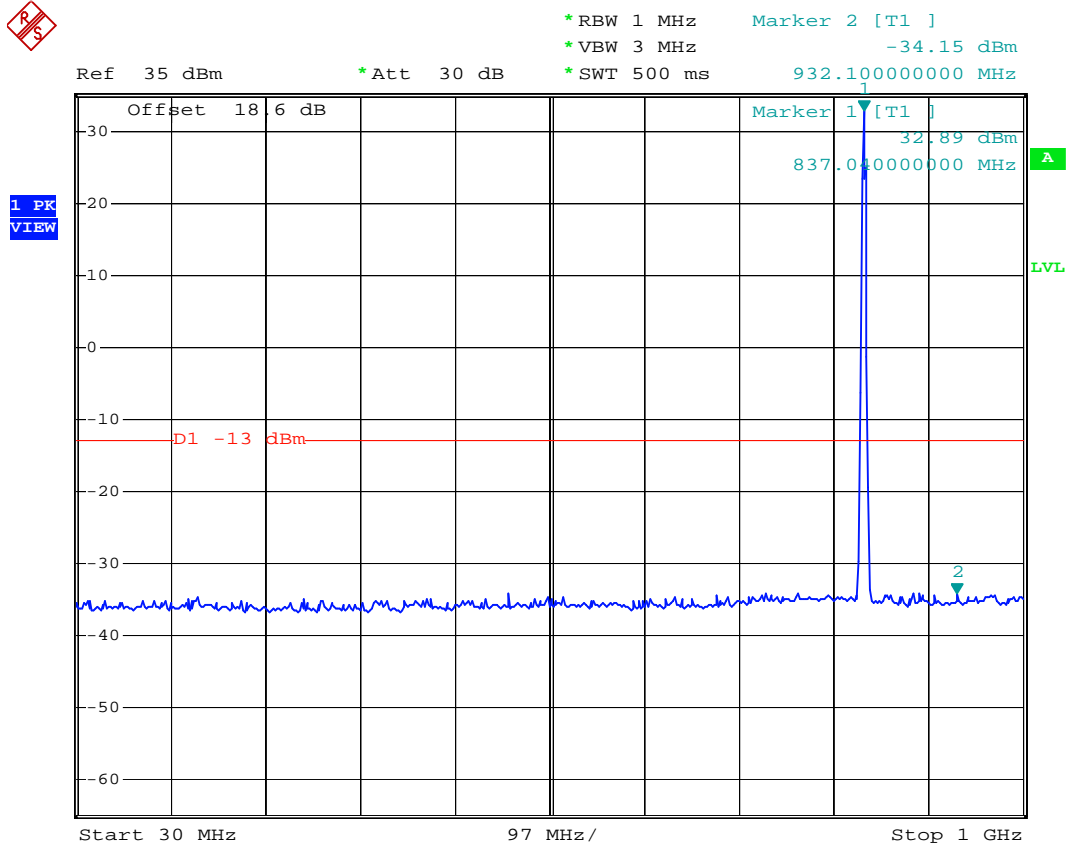

Date: 11.SEP.2007 19:19:20



- Test Mode : GSM850 (GSM) CH189
- Frequency Range : 1G-3G



\*RBW 1 MHz      Marker 2 [T1 ]  
 \*VBW 3 MHz      -51.90 dBm  
 \*SWT 500 ms      2.512000000 GHz

Ref 0 dBm

\*Att 0 dB

1 PK  
VIEW

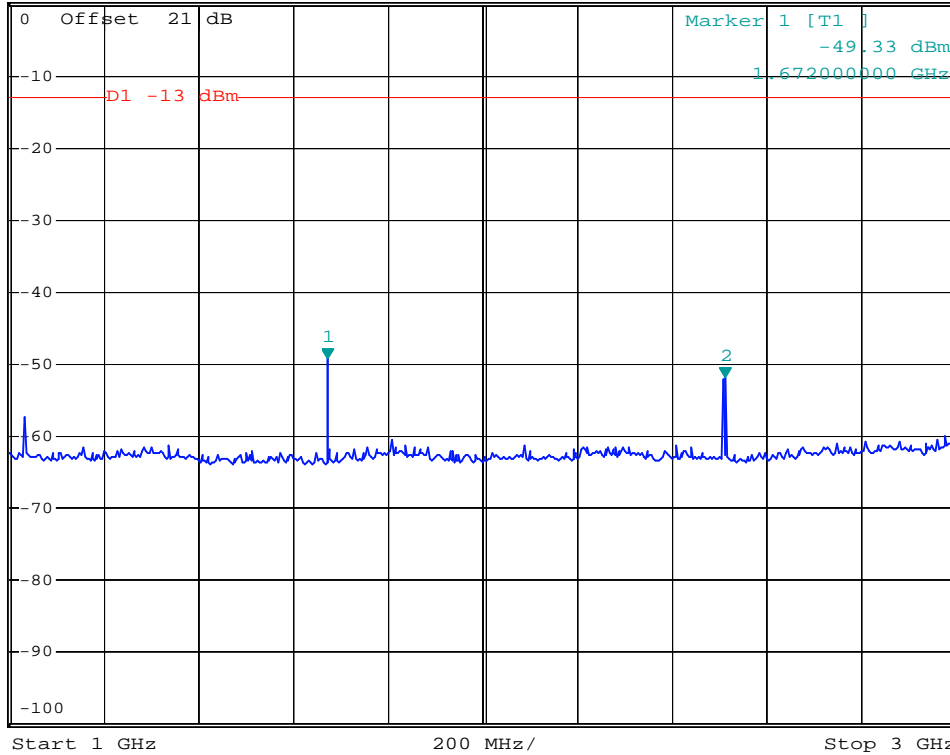

Date: 11.SEP.2007 19:24:08



- Test Mode : GSM850 (GSM) CH189
- Frequency Range : 3G-7G



\*RBW 1 MHz      Marker 3 [T1 ]  
 \*VBW 3 MHz      -48.01 dBm  
 \*SWT 500 ms      4.184000000 GHz

Ref 0 dBm

\*Att 0 dB

1 PK  
VIEW

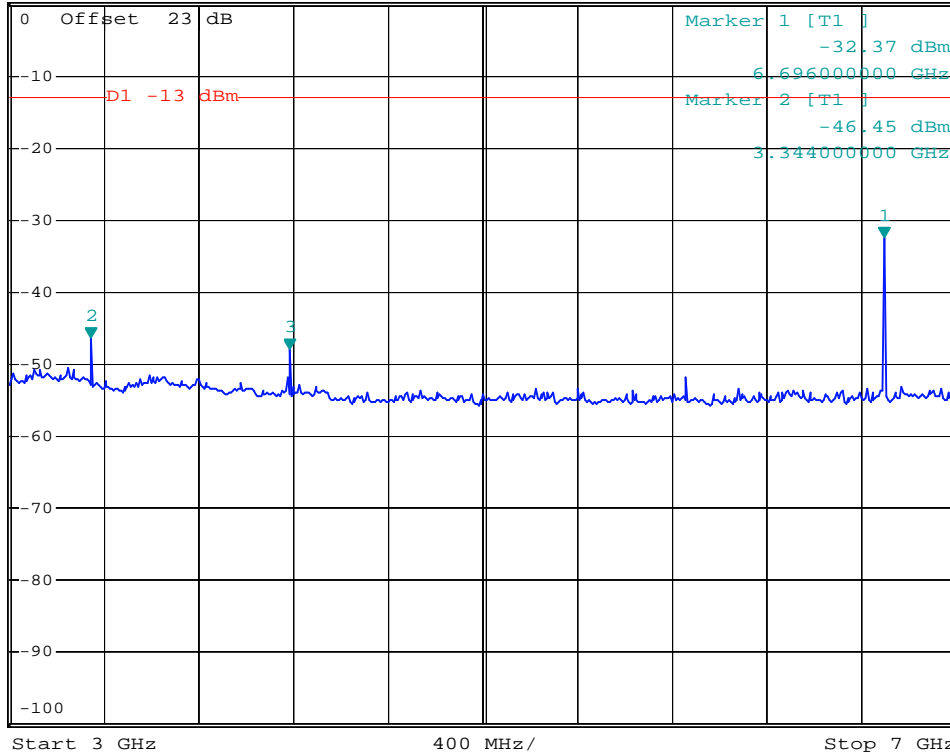

Date: 11.SEP.2007 19:25:44





- Test Mode : GSM850 (GSM) CH189
- Frequency Range : 7G-9G



\*RBW 1 MHz      Marker 2 [T1 ]  
 \*VBW 3 MHz      -44.29 dBm  
 \*SWT 500 ms      8.364000000 GHz

Ref 0 dBm

\*Att 0 dB

1 PK  
MAXH

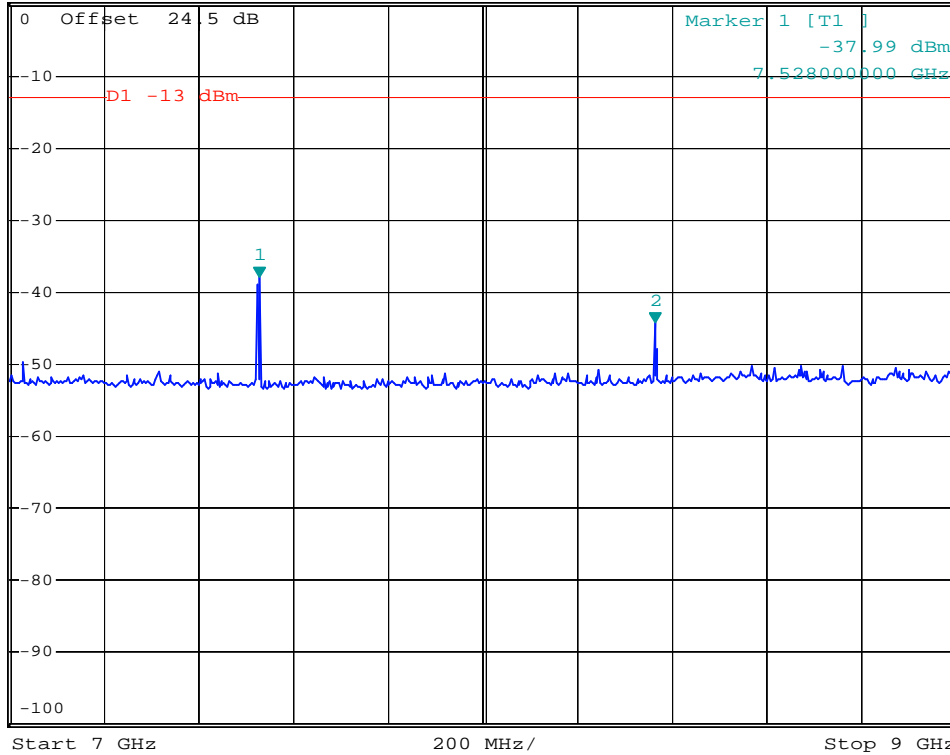

Date: 11.SEP.2007 19:32:17



- Mode 2
- Test Mode : GSM850 (EDGE) CH189
- Frequency Range : 30M-1G



Ref 35 dBm      \*Att 30 dB      \*RBW 1 MHz      Marker 2 [T1 ]  
 \*VBW 3 MHz      -33.37 dBm  
 \*SWT 500 ms      848.68000000 MHz

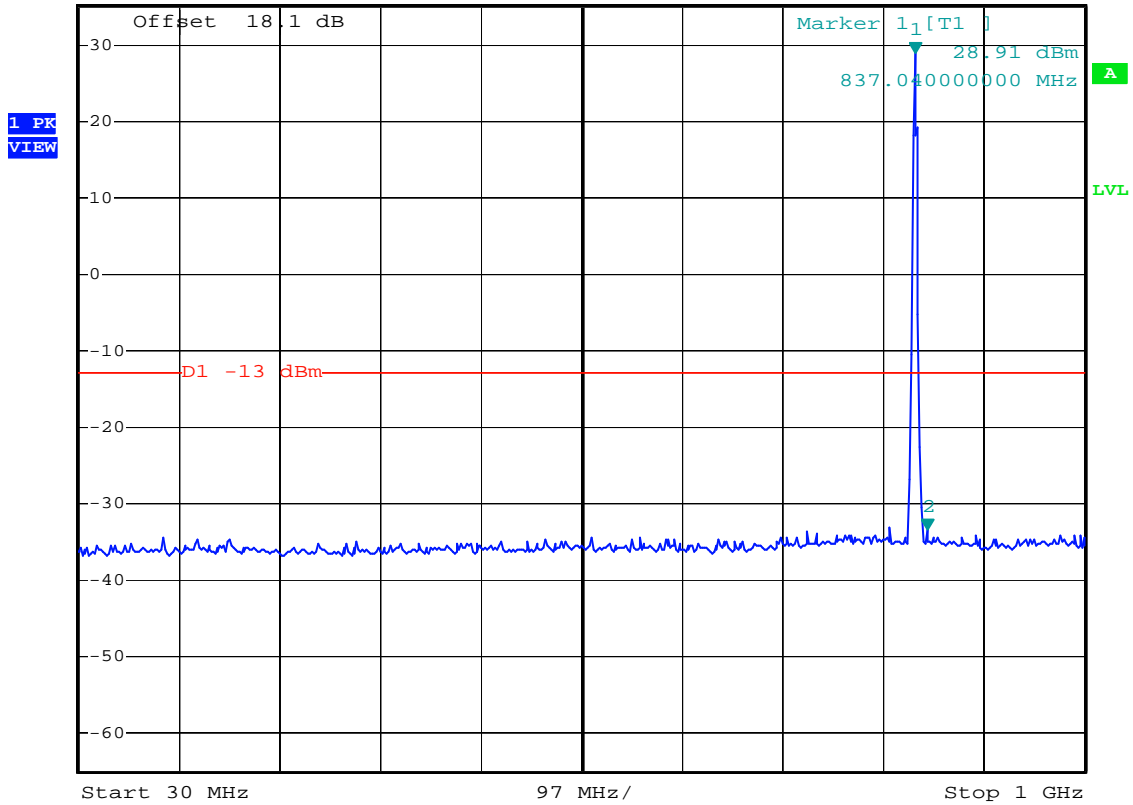

Date: 20.SEP.2007 14:59:12



- Test Mode : GSM850 (EDGE) CH189
- Frequency Range : 1G-3G



Ref 0 dBm      \*Att 0 dB      \*RBW 1 MHz      Marker 1 [T1 ]  
 \*VBW 3 MHz      -59.09 dBm  
 \*SWT 500 ms      1.96000000 GHz

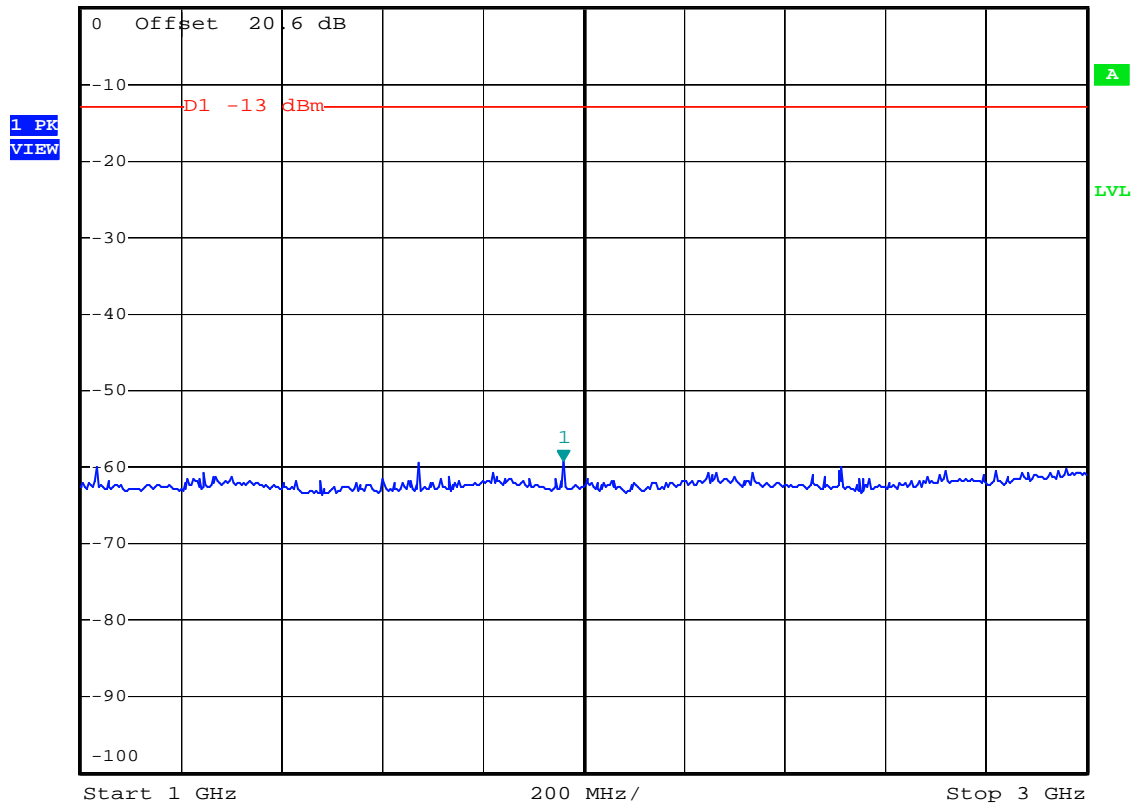

Date: 20.SEP.2007 15:05:55



- Test Mode : GSM850 (EDGE) CH189
- Frequency Range : 3G-7G



Ref 0 dBm      \*Att 0 dB      \*RBW 1 MHz      Marker 2 [T1 ]  
 \*VBW 3 MHz      -47.91 dBm  
 \*SWT 500 ms      3.344000000 GHz

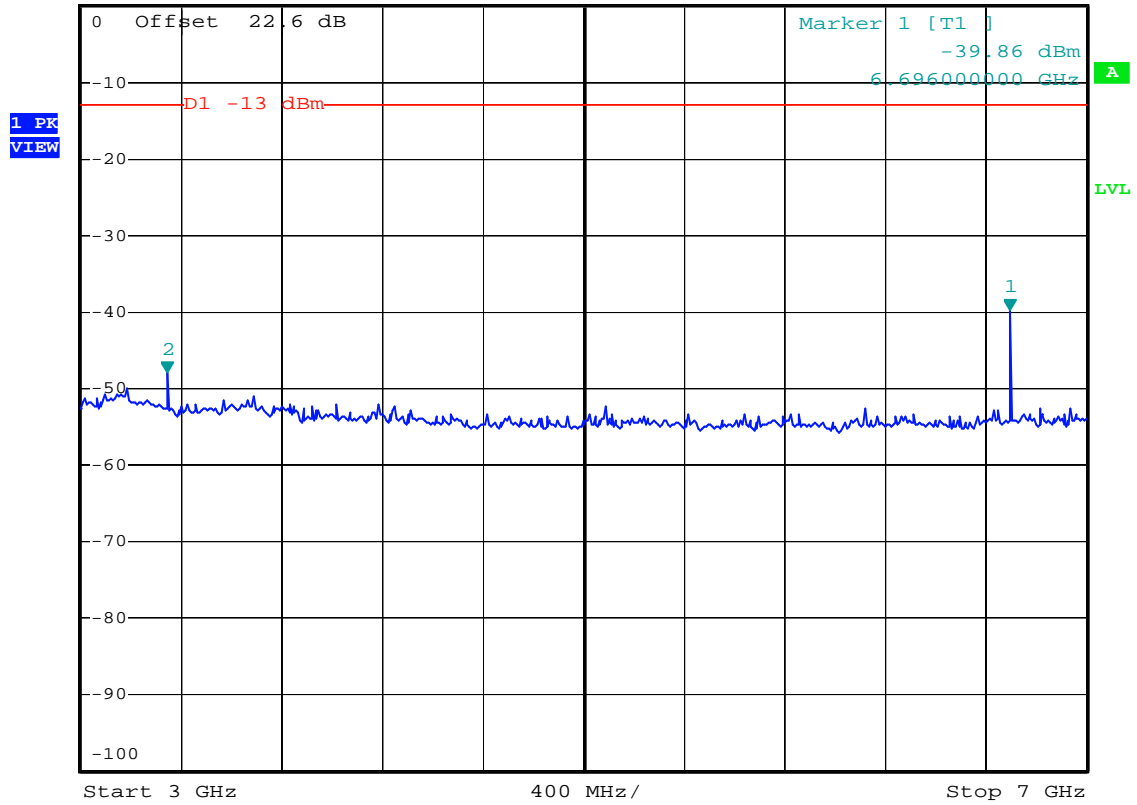

Date: 20.SEP.2007 15:07:16



- Test Mode : GSM850 (EDGE) CH189
- Frequency Range : 7G-9G



\*RBW 1 MHz      Marker 1 [T1 ]  
\*VBW 3 MHz      -40.98 dBm  
\*SWT 500 ms      7.52800000 GHz

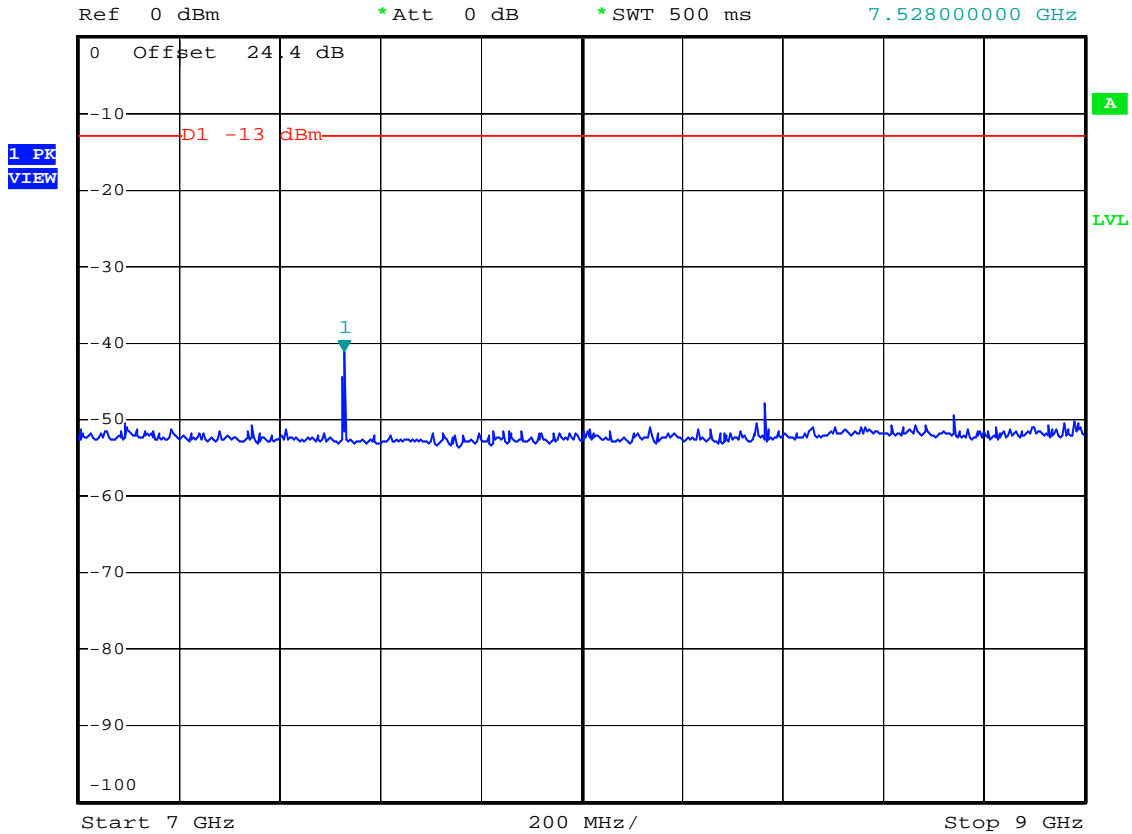

Date: 20.SEP.2007 15:11:06



- Mode 3
- Test Mode : PCS1900 (GSM) CH661
- Frequency Range : 30M-1G



Ref 30 dBm      \*Att 30 dB      \*RBW 1 MHz      Marker 1 [T1 ]  
 \*VBW 3 MHz      -27.96 dBm  
 \*SWT 500 ms      140.58000000 MHz

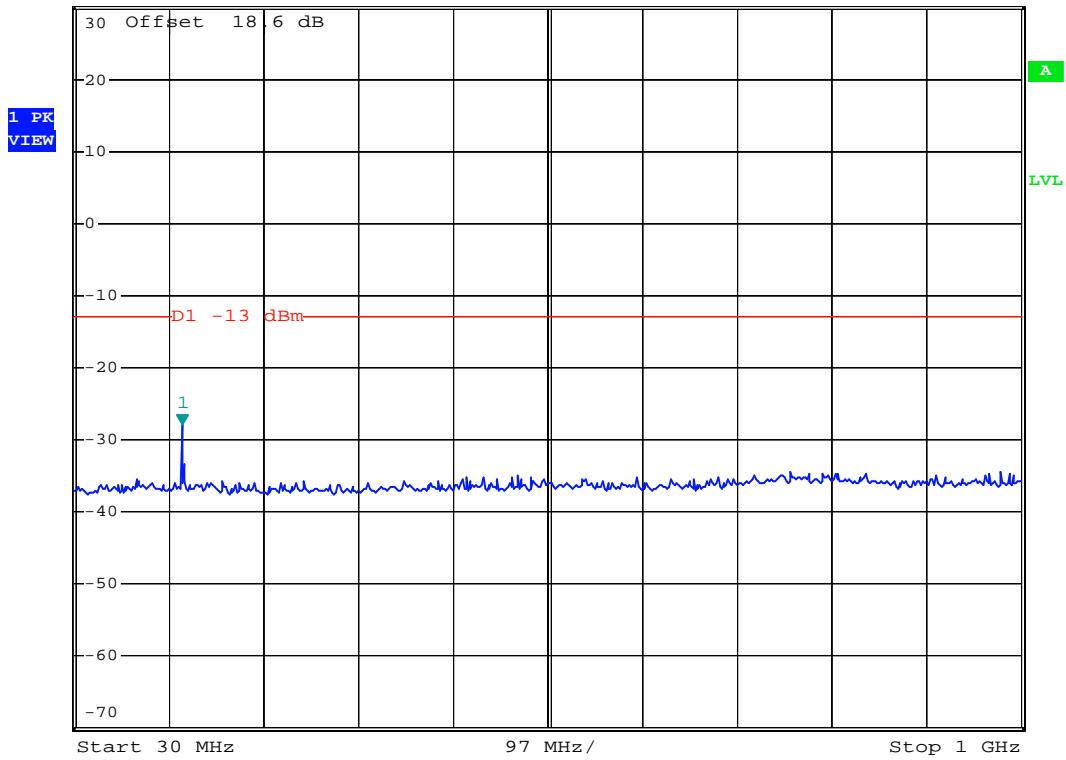

Date: 11.SEP.2007 19:04:13



- Test Mode : PCS1900 (GSM) CH661
- Frequency Range : 1G-3G



Ref 35 dBm      \*Att 30 dB      \*RBW 1 MHz      Marker 2 [T1]      -29.56 dBm  
 \*VBW 3 MHz      \*SWT 500 ms      2.980000000 GHz

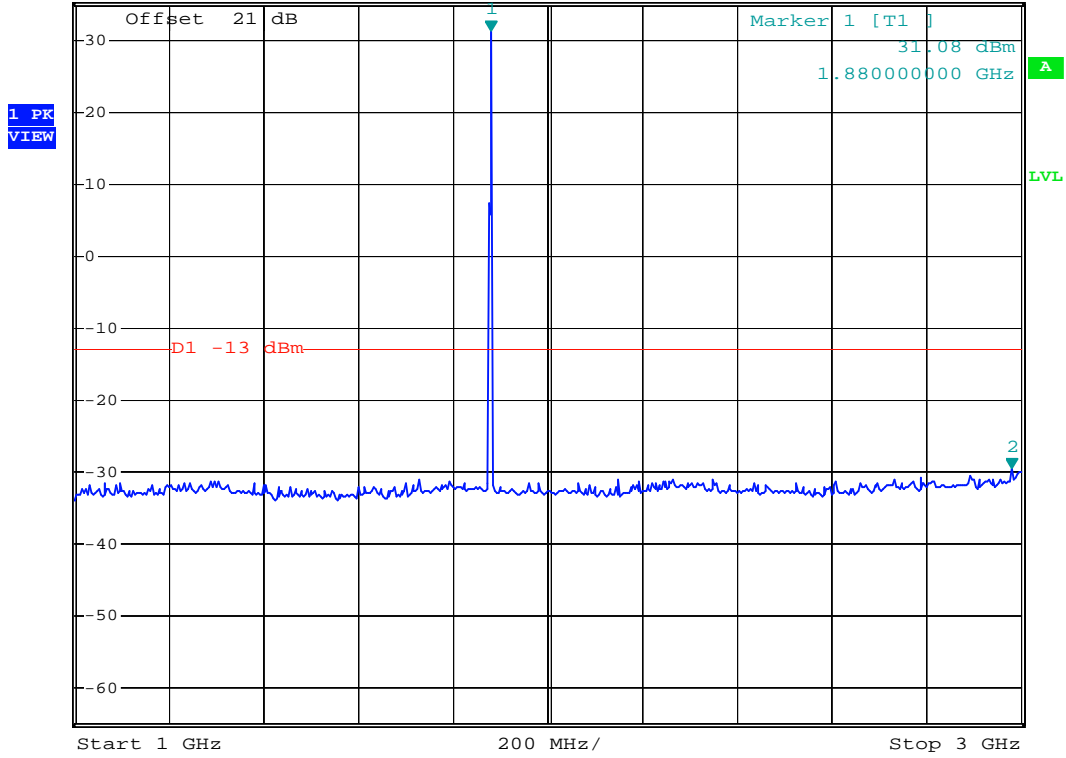

Date: 11.SEP.2007 19:22:16



- Test Mode : PCS1900 (GSM) CH661
- Frequency Range : 3G-7G



\*RBW 1 MHz      Marker 1 [T1 ]  
\*VBW 3 MHz      -45.30 dBm  
\*SWT 500 ms      3.76000000 GHz

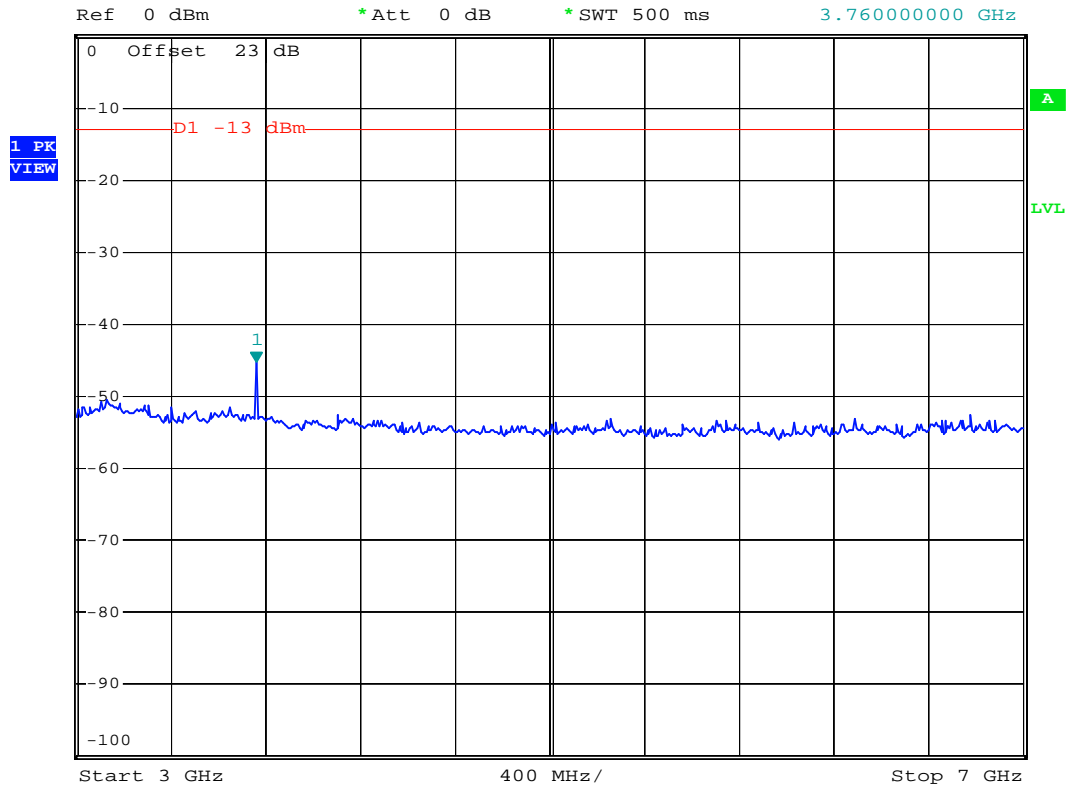

Date: 11.SEP.2007 19:27:16





- Test Mode : PCS1900 (GSM) CH661
- Frequency Range : 7G-13.6G



\*RBW 1 MHz      Marker 2 [T1 ]  
 \*VBW 3 MHz      -45.59 dBm  
 \*SWT 500 ms      9.402400000 GHz

Ref 0 dBm

\*Att 0 dB

1 PK  
VIEW

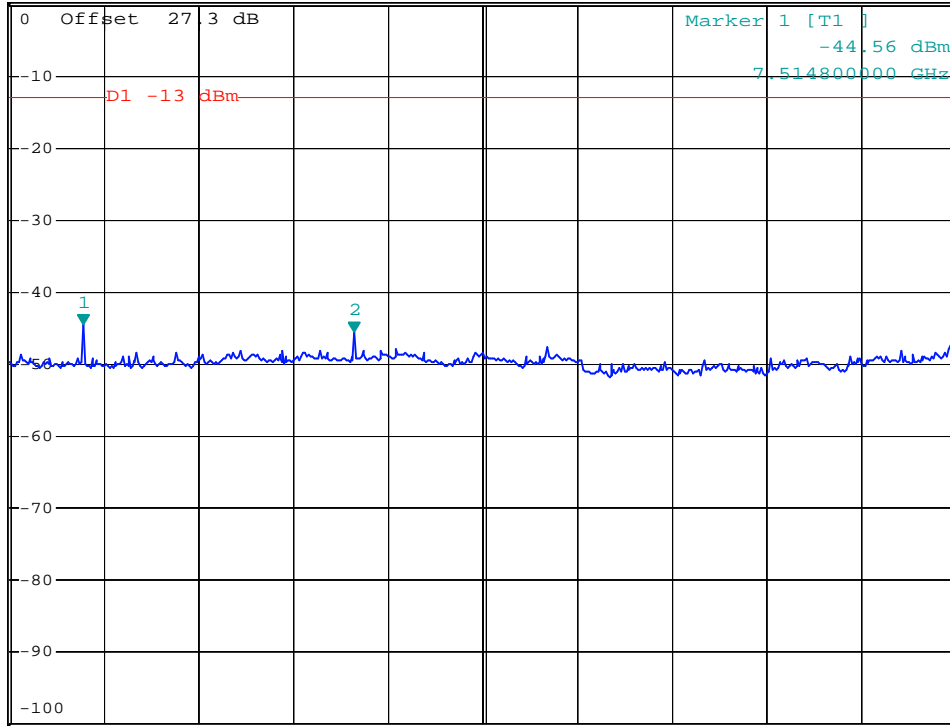

Start 7 GHz

660 MHz/

Stop 13.6 GHz

Date: 11.SEP.2007 19:29:18



- Test Mode : PCS1900 (GSM) CH661
- Frequency Range : 13.6G-19.1G



\*RBW 1 MHz      Marker 1 [T1 ]  
 \*VBW 3 MHz      -26.56 dBm  
 \*SWT 500 ms      15.019000000 GHz

Ref 0 dBm

\*Att 0 dB

1 PK  
VIEW

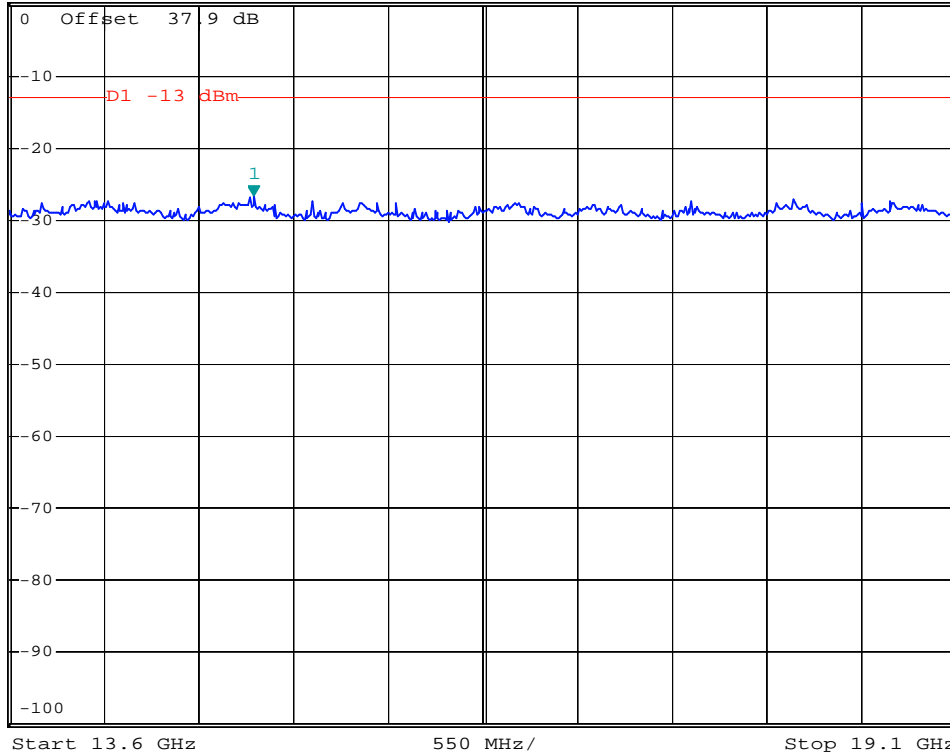

Date: 11.SEP.2007 19:34:11



- Mode 4
- Test Mode : PCS1900 (EDGE) CH661
- Frequency Range : 30M-1G



Ref 30 dBm      \*Att 30 dB      \*RBW 1 MHz      Marker 1 [T1 ]  
 \*VBW 3 MHz      -34.25 dBm  
 \*SWT 500 ms      916.58000000 MHz

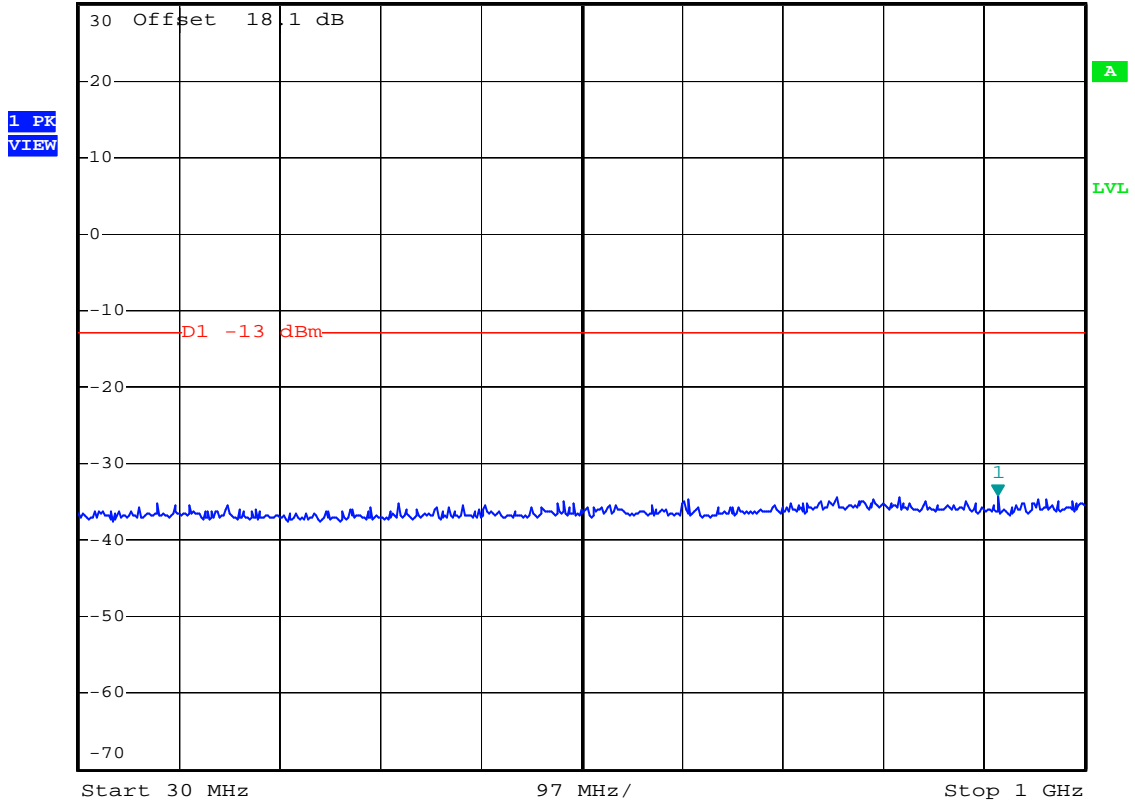

Date: 20.SEP.2007 14:56:52



- Test Mode : PCS1900 (EDGE) CH661
- Frequency Range : 1G-3G



Ref 35 dBm      \*Att 30 dB      \*RBW 1 MHz      Marker 2 [T1 ]  
 \*VBW 3 MHz      -28.72 dBm  
 \*SWT 500 ms      1.764000000 GHz

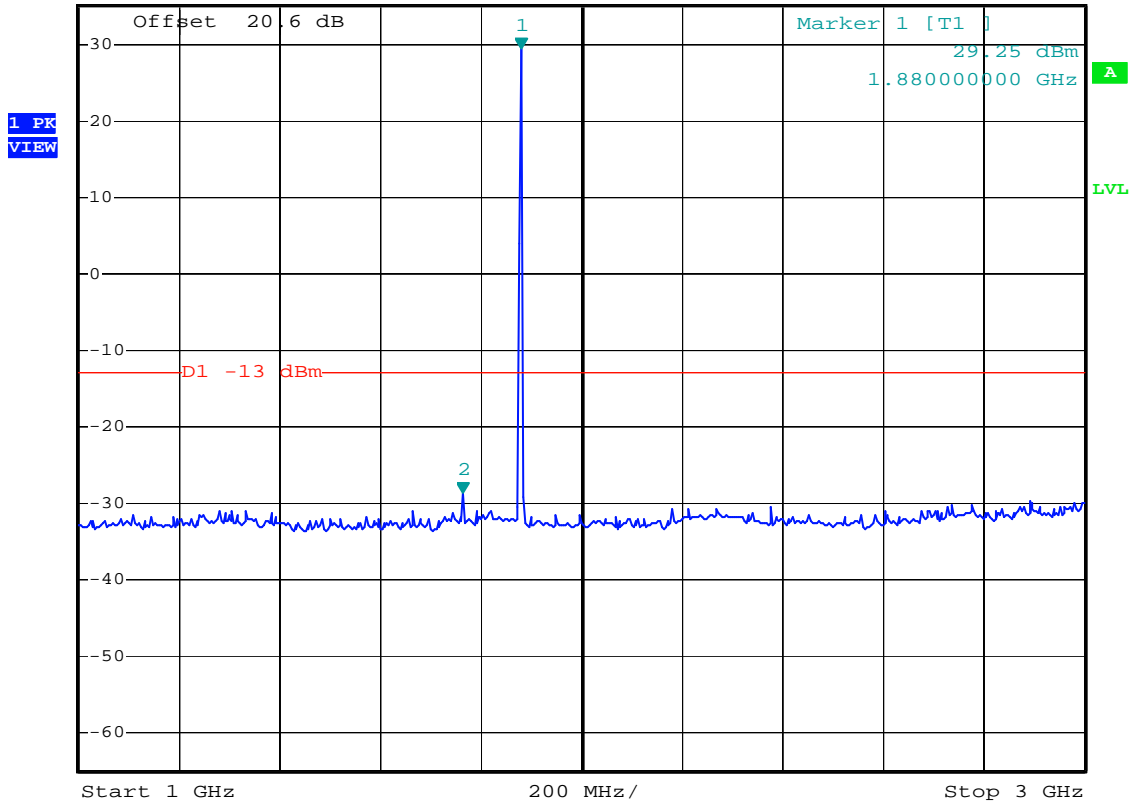

Date: 20.SEP.2007 15:02:22



- Test Mode : PCS1900 (EDGE) CH661
- Frequency Range : 3G-7G



\*RBW 1 MHz      Marker 1 [T1 ]  
\*VBW 3 MHz      -41.04 dBm  
\*SWT 500 ms      3.760000000 GHz

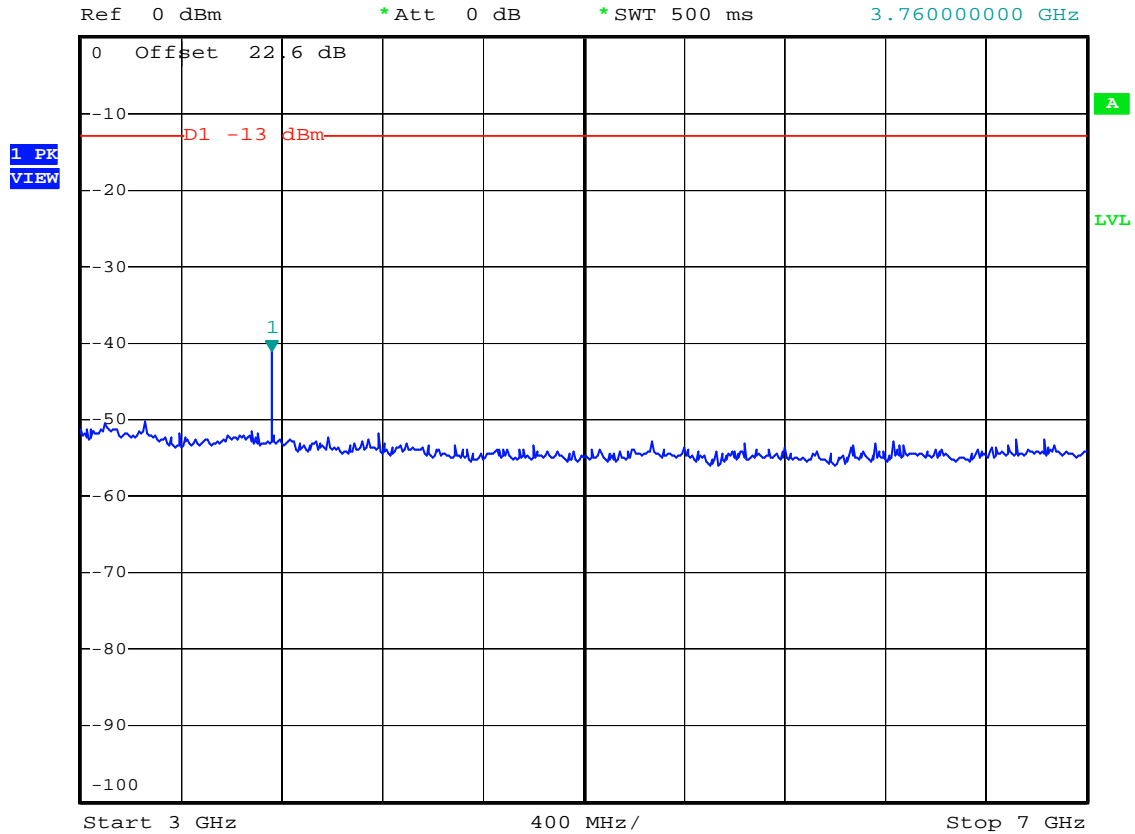

Date: 20.SEP.2007 15:08:18



- Test Mode : PCS1900 (EDGE) CH661
- Frequency Range : 7G-13.6G



\*RBW 1 MHz      Marker 1 [T1 ]  
 \*VBW 3 MHz      -44.57 dBm  
 \*SWT 500 ms      7.51480000 GHz

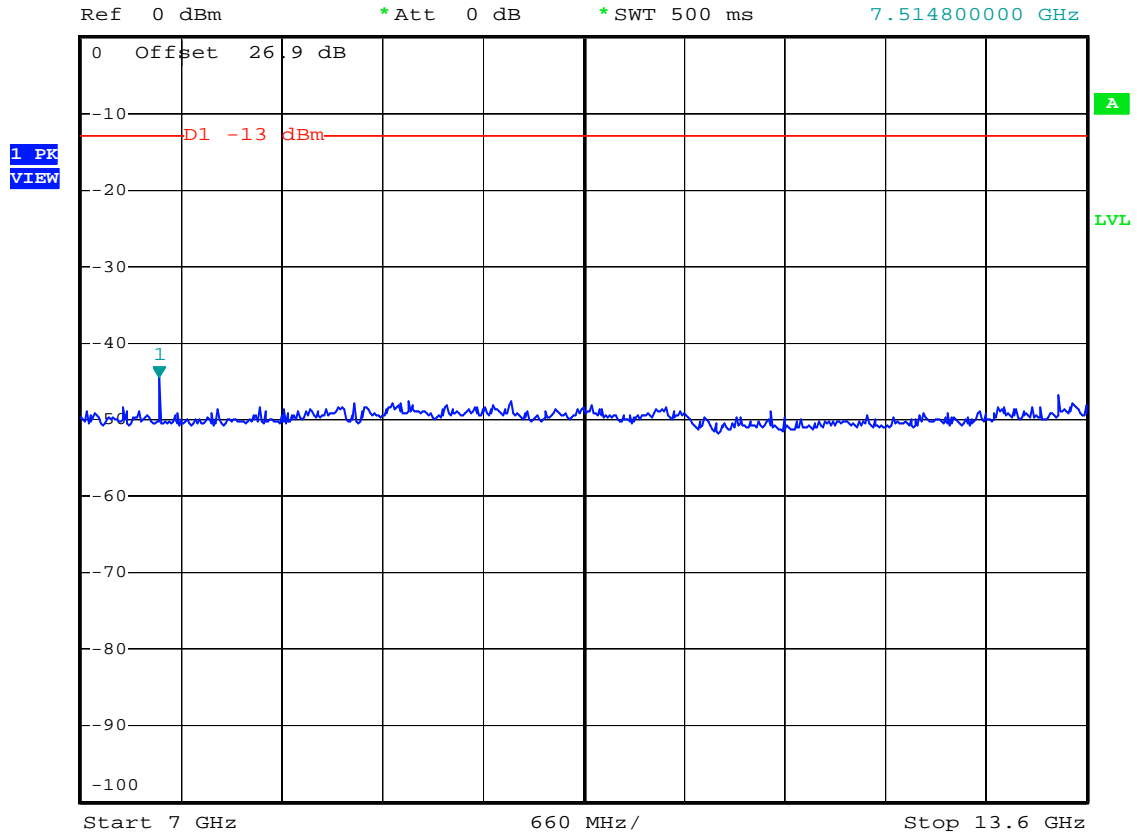

Date: 20.SEP.2007 15:12:14



- Test Mode : PCS1900 (EDGE) CH661
- Frequency Range : 13.6G-19.1G



\*RBW 1 MHz      Marker 1 [T1 ]  
 \*VBW 3 MHz      -26.53 dBm  
 \*SWT 500 ms      14.007000000 GHz

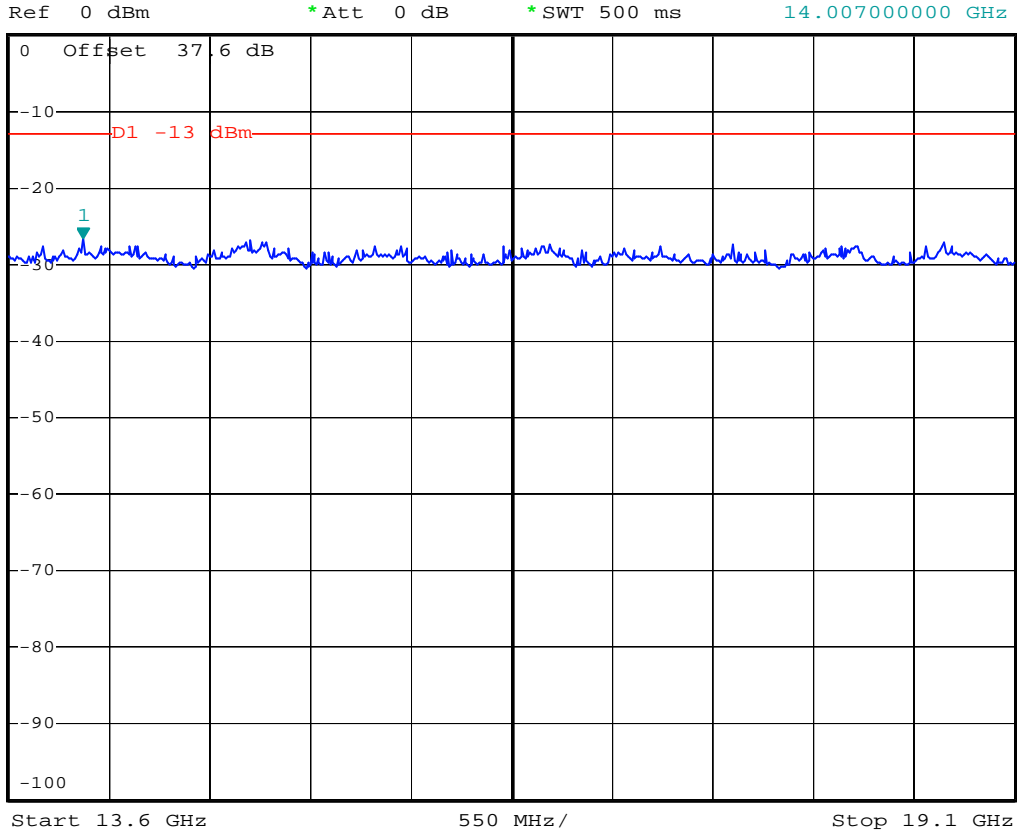

Date: 20.SEP.2007 15:13:05

## 4.6 Field Strength of Spurious Radiation

Equivalent isotropic radiated Power Measurements by substitution method according to ANSI/TIA/EIA-603-C.

### 4.6.1 Measurement Instruments

As described in chapter 5 of this test report.

### 4.6.2 Test Procedure

1. The EUT was placed on a rotatable wooden table with 0.8 meter about ground.
2. The EUT was set 3 meters from the receiving antenna which was mounted on the antenna tower.
3. The table was rotated 360 degrees to determine the position of the highest spurious emission.
4. The height of the receiving antenna is varied between one meter and four meters to reach the maximum spurious emission for both horizontal and vertical polarizations.
5. Taking the record of maximum spurious emission.
6. A Horn antenna was substituted in place of the EUT and was driven by a signal generator.
7. Tune the output power of signal generator to the same emission level with EUT maximum spurious emission.
8. Taking the record of output power at antenna port.
9. Repeat step 7 to step 8 for another polarization.
10. Emission level (dBm) = output power + substitution Gain.

### 4.6.3 Test Setup Layout

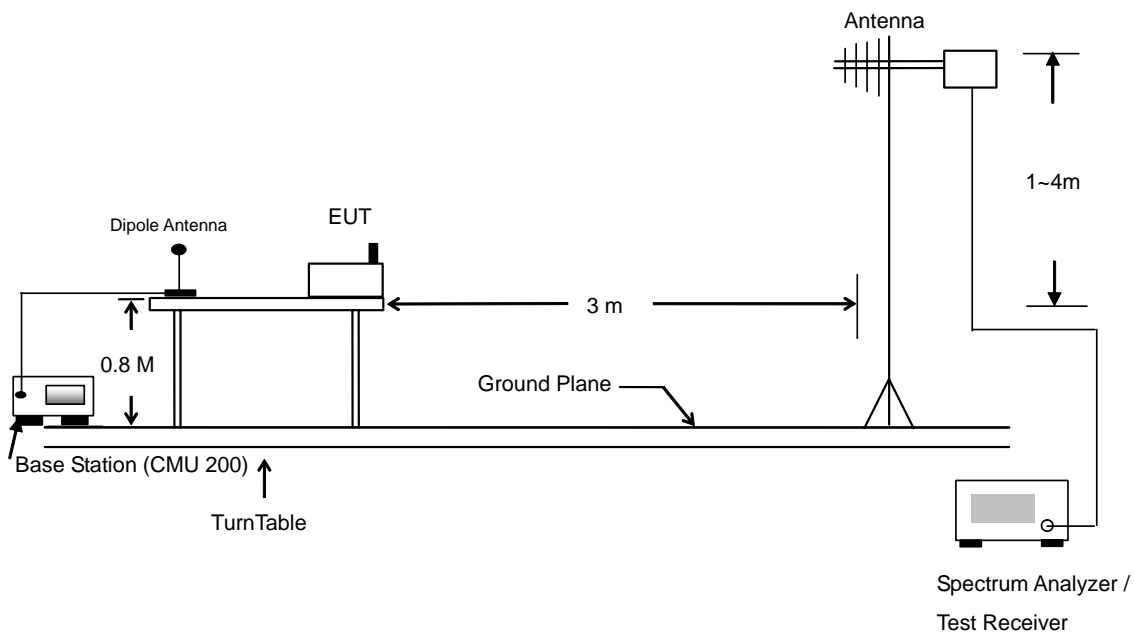





4.6.4 Test Result

• Test Mode : Mode 1

GSM850 (GSM) Radiated Spurious ERP							
H Polarization				V Polarization			
Frequency (MHz)	ERP (dBm)	Limit (dBm)	Margin (dB)	Frequency (MHz)	ERP (dBm)	Limit (dBm)	Margin (dB)
30.540	-63.170	-13	-50.17	32.430	-62.930	-13	-49.93
66.180	-62.210	-13	-49.21	48.630	-66.920	-13	-53.92
99.390	-67.320	-13	-54.32	70.230	-55.350	-13	-42.35
607.300	-69.600	-13	-56.60	679.400	-66.320	-13	-53.32
1674.000	-38.990	-13	-25.99	1674.000	-44.510	-13	-31.51
2508.000	-42.210	-13	-29.21	2508.000	-42.360	-13	-29.36
3344.000	-49.800	-13	-36.80	3344.000	-47.710	-13	-34.71
6688.000	-33.190	-13	-20.19	5854.000	-42.090	-13	-29.09
7528.000	-42.270	-13	-29.27	6688.000	-32.210	-13	-19.21
				8364.000	-37.790	-13	-24.79

• Test Mode : Mode 2

GSM850 (EDGE) Radiated Spurious ERP							
H Polarization				V Polarization			
Frequency (MHz)	ERP (dBm)	Limit (dBm)	Margin (dB)	Frequency (MHz)	ERP (dBm)	Limit (dBm)	Margin (dB)
31.080	-63.310	-13	-50.31	32.430	-64.860	-13	-51.86
67.530	-62.550	-13	-49.55	69.690	-56.900	-13	-43.90
194.430	-66.960	-13	-53.96	97.230	-63.830	-13	-50.83
665.400	-68.840	-13	-55.84	309.800	-61.150	-13	-48.15
1674.000	-47.320	-13	-34.32	1674.000	-53.400	-13	-40.40
2508.000	-52.250	-13	-39.25	2508.000	-53.040	-13	-40.04
6688.000	-35.900	-13	-22.90	6688.000	-34.880	-13	-21.88
8364.000	-36.500	-13	-23.50	8364.000	-39.970	-13	-26.97



- Test Mode : Mode 3

PCS1900 (GSM) Radiated Spurious EIRP							
H Polarization				V Polarization			
Frequency (MHz)	EIRP (dBm)	Limit (dBm)	Margin (dB)	Frequency (MHz)	EIRP (dBm)	Limit (dBm)	Margin (dB)
31.080	-60.030	-13	-47.03	33.240	-57.430	-13	-44.43
70.230	-57.100	-13	-44.10	48.630	-52.770	-13	-39.77
95.340	-61.860	-13	-48.86	71.580	-47.380	-13	-34.38
616.400	-67.370	-13	-54.37	733.300	-63.790	-13	-50.79
777.400	-65.690	-13	-52.69	890.800	-61.880	-13	-48.88
962.900	-64.190	-13	-51.19	978.300	-61.190	-13	-48.19
3758.000	-47.810	-13	-34.81	3758.000	-44.630	-13	-31.63
5638.000	-38.080	-13	-25.08	5638.000	-32.930	-13	-19.93
9398.000	-39.880	-13	-26.88	9398.000	-39.920	-13	-26.92
11278.000	-36.270	-13	-23.27				

- Test Mode : Mode 4

PCS1900 (EDGE) Radiated Spurious EIRP							
H Polarization				V Polarization			
Frequency (MHz)	EIRP (dBm)	Limit (dBm)	Margin (dB)	Frequency (MHz)	EIRP (dBm)	Limit (dBm)	Margin (dB)
33.240	-60.950	-13	-47.95	31.890	-57.780	-13	-44.78
65.640	-53.850	-13	-40.85	71.580	-47.680	-13	-34.68
140.430	-60.110	-13	-47.11	84.540	-51.190	-13	-38.19
745.900	-65.230	-13	-52.23	633.900	-64.890	-13	-51.89
848.800	-64.590	-13	-51.59	794.900	-62.980	-13	-49.98
918.800	-63.860	-13	-50.86	901.300	-61.540	-13	-48.54
3758.000	-47.650	-13	-34.65	3758.000	-47.050	-13	-34.05
5638.000	-39.280	-13	-26.28	5638.000	-34.600	-13	-21.60
9398.000	-37.930	-13	-24.93	9398.000	-41.260	-13	-28.26



• Test Mode : Mode 5

GSM850 (GSM) with WLAN Radiated Spurious ERP							
H Polarization				V Polarization			
Frequency (MHz)	ERP (dBm)	Limit (dBm)	Margin (dB)	Frequency (MHz)	ERP (dBm)	Limit (dBm)	Margin (dB)
34.590	-53.480	-13	-40.48	35.130	-55.290	-13	-42.29
64.830	-50.450	-13	-37.45	73.740	-46.650	-13	-33.65
91.290	-60.000	-13	-47.00	82.380	-50.480	-13	-37.48
743.800	-57.460	-13	-44.46	743.800	-58.210	-13	-45.21
1674.000	-19.530	-13	-6.53	1674.000	-19.570	-13	-6.57
2508.000	-32.110	-13	-19.11	2508.000	-35.170	-13	-22.17
3344.000	-39.550	-13	-26.55	3344.000	-42.730	-13	-29.73
4184.000	-49.530	-13	-36.53	4184.000	-47.580	-13	-34.58
5018.000	-40.180	-13	-27.18	4824.000	-48.050	-13	-35.05
5854.000	-38.770	-13	-25.77	5018.000	-39.970	-13	-26.97
6688.000	-30.740	-13	-17.74	5854.000	-36.680	-13	-23.68
7528.000	-42.370	-13	-29.37	6688.000	-29.360	-13	-16.36
				7528.000	-41.190	-13	-28.19



4.6.5 Test Data

4.6.5.1 Mode 1

Horizontal Polarization

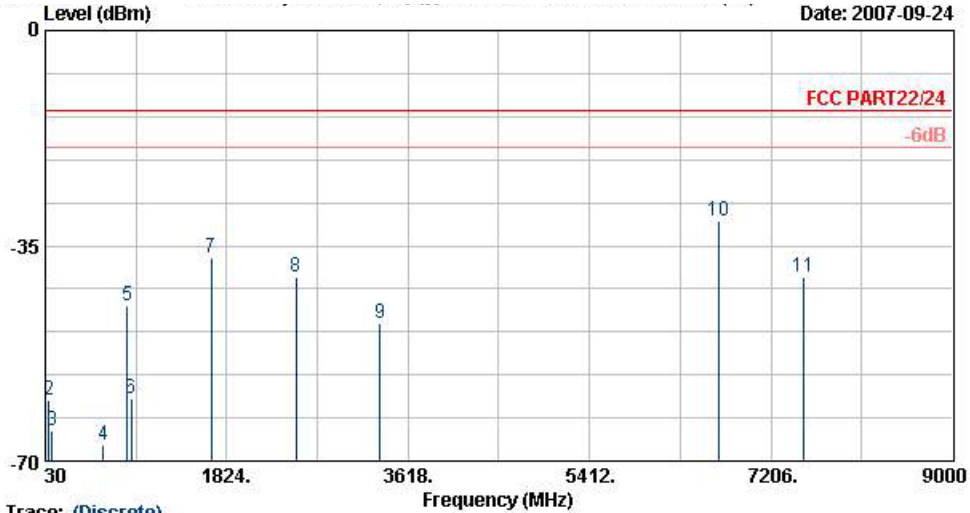

Trace: (Discrete)

Site : 03CHD6-HY  
 Condition : HF-SPURIOUS-060929 HORIZONTAL  
 EUT : GSM/EDGE 850/900/1800/1900 Smart Phone  
 with BT, EDR, 802.11g, GFS, FM  
 Power : 120V<sub>ac</sub>/60Hz  
 Model : FG 781408  
 Memo : GSM 850 Link;Ch189+Earphone+Adaptor  
 Plane : E2

	Freq	Level	Over	Limit	Read	Factor	Remark
	MHz	dBm	Limit	Line	Level	dB	
1	30.5	-61.02	-48.02	-13.00	-60.77	-0.25	Peak
2	66.2	-60.06	-47.06	-13.00	-47.69	-12.37	Peak
3	99.4	-65.17	-52.17	-13.00	-52.93	-12.24	Peak
4	607.3	-67.45	-54.45	-13.00	-63.78	-3.67	Peak
5	836.9	-44.86			-43.53	-1.33	Peak
6	880.3	-59.98			-59.07	-0.91	Peak
7	1674.0	-36.84	-23.84	-13.00	-39.20	2.36	Peak
8	2508.0	-40.06	-27.06	-13.00	-46.75	6.69	Peak
9	3344.0	-47.65	-34.65	-13.00	-57.05	9.40	Peak
10	6688.0	-31.04	-18.04	-13.00	-51.23	20.19	Peak
11	7528.0	-40.12	-27.12	-13.00	-61.43	21.31	Peak

Remark:

1. #5: MS Signal
2. #6: BS Signal



Vertical Polarization

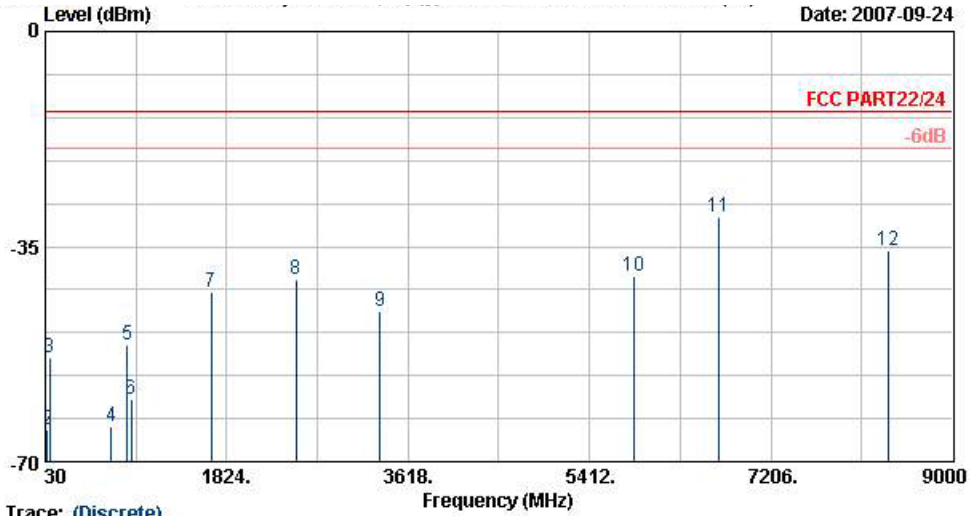

Trace: (Discrete)

Site : 03CHD6-HY  
 Condition : HF-SPURIOUS-060929 VERTICAL  
 EUT : GSM/EDGE 850/900/1800/1900 Smart Phone  
 : with BT, EDR, 802.11g, GPS, FM  
 Power : 120Vac/60Hz  
 Model : FG 781408  
 Memo : GSM 850 Link;CH189+Earphone+Adaptor  
 Plane : E2

	Freq	Level	Over	Limit	Read		
	MHz	dBm	Limit	Line	Level	Factor	Remark
			dB	dBm	dBm	dB	
1	32.4	-60.78	-47.78	-13.00	-50.89	-9.89	Peak
2	48.6	-64.77	-51.77	-13.00	-50.50	-14.27	Peak
3	70.2	-53.20	-40.20	-13.00	-41.17	-12.02	Peak
4	679.4	-64.17	-51.17	-13.00	-63.42	-0.75	Peak
5	836.9	-51.09			-52.45	1.36	Peak
6	880.3	-59.80			-61.51	1.71	Peak
7	1674.0	-42.36	-29.36	-13.00	-44.52	2.16	Peak
8	2508.0	-40.21	-27.21	-13.00	-47.39	7.18	Peak
9	3344.0	-45.56	-32.56	-13.00	-54.11	8.55	Peak
10	5854.0	-39.94	-26.94	-13.00	-58.43	18.49	Peak
11 @	6688.0	-30.06	-17.06	-13.00	-48.74	18.68	Peak
12	8364.0	-35.64	-22.64	-13.00	-58.40	22.75	Peak

Remark:

- #5: MS Signal
- #6: BS Signal
- There is no more obvious emission except the listings above.



4.6.5.2 Mode 2

Horizontal Polarization

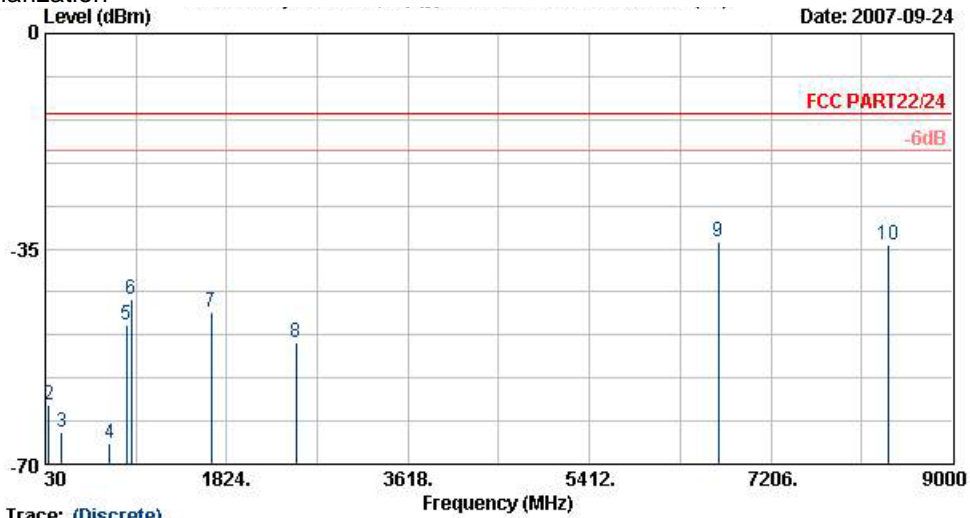

Date: 2007-09-24

Trace: (Discrete)

Site : 08CH06-HY  
 Condition : HF-SPURIOUS-060929 HORIZONTAL  
 EUT : GSM/EDGE 850/900/1800/1900 Smart Phone  
 with BT, EDR, 802.11g, GFS, FM  
 Power : 120V<sub>ac</sub>/60Hz  
 Model : FG 781408  
 Memo : EDGE Link; CH189+Earphone+Adaptor  
 Plane : E2

	Freq	Level	Over	Limit	Read		
	MHz	dBm	Limit	Line	Level	Factor	Remark
			dB	dBm	dBm	dB	
1	31.1	-61.16	-48.16	-13.00	-60.92	-0.25	Peak
2	67.5	-60.40	-47.40	-13.00	-48.03	-12.36	Peak
3	194.4	-64.81	-51.81	-13.00	-51.48	-13.33	Peak
4	665.4	-66.69	-53.69	-13.00	-63.62	-3.07	Peak
5	833.4	-47.29			-45.92	-1.37	Peak
6	880.3	-43.19			-42.28	-0.91	Peak
7	1674.0	-45.17	-32.17	-13.00	-47.52	2.36	Peak
8	2508.0	-50.10	-37.10	-13.00	-56.79	6.69	Peak
9 @	6688.0	-33.75	-20.75	-13.00	-53.94	20.19	Peak
10	8364.0	-34.35	-21.35	-13.00	-58.32	23.97	Peak

Remark:

1. #5: MS Signal
2. #6: BS Signal



Vertical Polarization

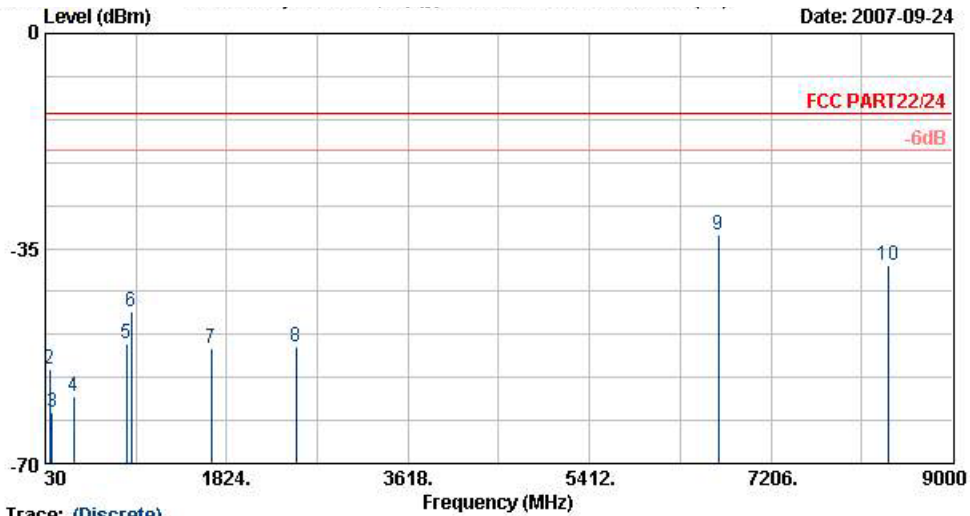

Date: 2007-09-24

Trace: (Discrete)

Site : 03CHD6-HY  
 Condition : HF-SPURIOUS-060929 VERTICAL  
 EUT : GSM/EDGE 850/900/1800/1900 Smart Phone  
 with BT, EDR, 802.11g, GFS, FM  
 Power : 120V<sub>ac</sub>/60Hz  
 Model : FG 781408  
 Memo : EDGE Link;Ch189+Earphone+Adaptor  
 Plane : E2

	Freq	Level	Over	Limit	Read	Factor	Remark
	MHz	dBm	dB	dBm	dBm	dB	
1	32.4	-62.71	-49.71	-13.00	-52.82	-9.89	Peak
2	69.7	-54.75	-41.75	-13.00	-42.73	-12.02	Peak
3	97.2	-61.68	-48.68	-13.00	-53.57	-8.11	Peak
4	309.8	-59.00	-46.00	-13.00	-52.74	-6.25	Peak
5	831.3	-50.59			-51.91	1.32	Peak
6	880.3	-45.19			-46.90	1.71	Peak
7	1674.0	-51.25	-38.25	-13.00	-53.41	2.16	Peak
8	2508.0	-50.89	-37.89	-13.00	-58.07	7.18	Peak
9 @	6688.0	-32.73	-19.73	-13.00	-51.42	18.68	Peak
10	8364.0	-37.82	-24.82	-13.00	-60.57	22.75	Peak

Remark:

- #5: MS Signal
- #6: BS Signal
- There is no more obvious emission except the listings above.



4.6.5.3 Mode 3

Horizontal Polarization

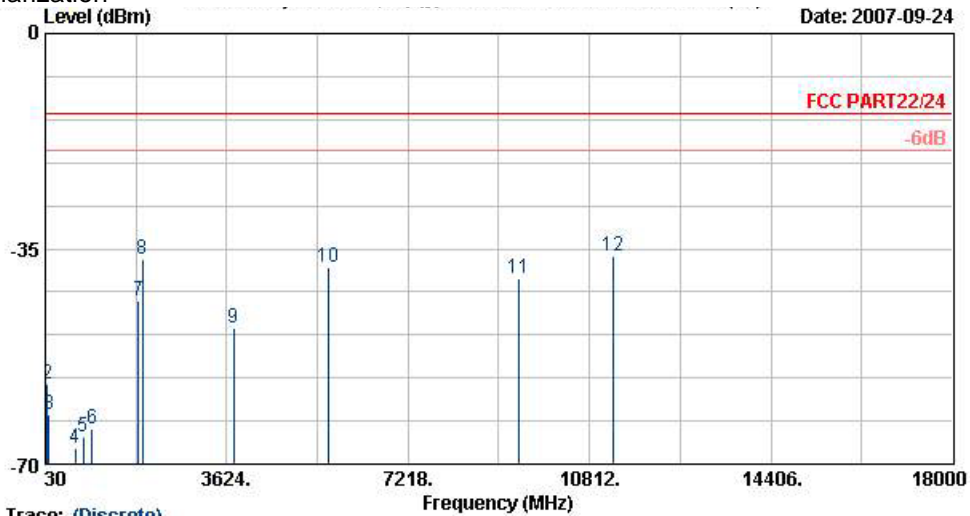

Date: 2007-09-24

Trace: (Discrete)

Site : 08CH06-HY  
 Condition : HF-SPURIOUS-060929 HORIZONTAL  
 EUT : GSM/EDGE 850/900/1800/1900 Smart Phone  
 with BT, EDR, 802.11g, GPS, FM  
 Power : 120V<sub>ac</sub>/60Hz  
 Model : FG 781408  
 Memo : PCS 1900 Link;Ch661+Earphone+Adaptor  
 Plane : E2

	Freq	Level	Over	Limit	Read		
	MHz	dBm	Limit	Line	Level	Factor	Remark
			dB	dBm	dBm	dB	
1	31.1	-60.03	-47.03	-13.00	-59.78	-0.25	Peak
2	70.2	-57.10	-44.10	-13.00	-44.74	-12.36	Peak
3	95.3	-61.86	-48.86	-13.00	-49.60	-12.26	Peak
4	616.4	-67.37	-54.37	-13.00	-63.80	-3.57	Peak
5	777.4	-65.69	-52.69	-13.00	-63.77	-1.92	Peak
6	962.9	-64.19	-51.19	-13.00	-64.08	-0.12	Peak
7	1878.0	-43.45			-47.35	3.90	Peak
8	1958.0	-36.70			-41.12	4.41	Peak
9	3758.0	-47.81	-34.81	-13.00	-58.21	10.41	Peak
10	5638.0	-38.08	-25.08	-13.00	-56.53	18.45	Peak
11	9398.0	-39.88	-26.88	-13.00	-61.28	21.40	Peak
12	11278.0	-36.27	-23.27	-13.00	-61.00	24.72	Peak

Remark:

- #7: MS Signal
- #8: BS Signal





Vertical Polarization

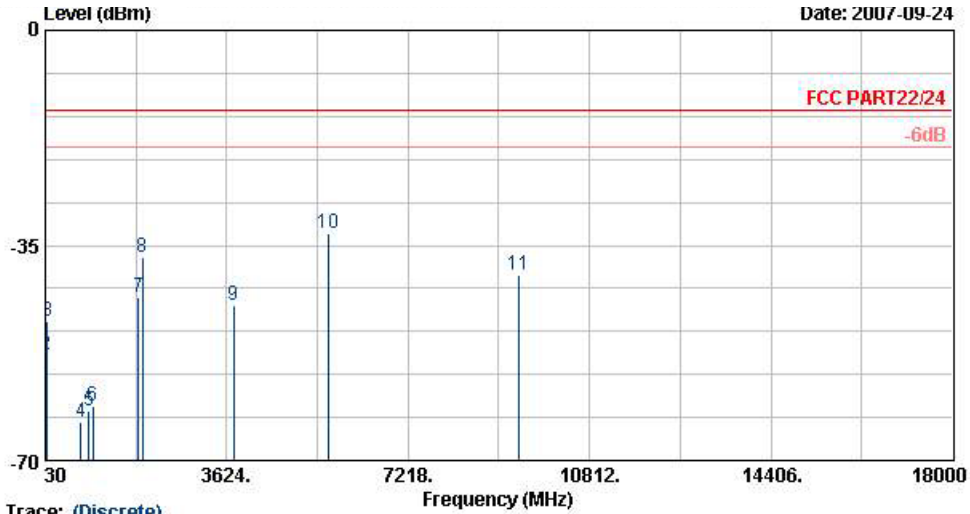

Trace: (Discrete)  
 Site : 08CHD6-HY  
 Condition : HF-SPURIOUS-060929 VERTICAL  
 EUT : GSM/EDGE 850/900/1800/1900 Smart Phone  
 : with BT, EDR, 802.11g, GPS, FM  
 Power : 120V<sub>ac</sub>/60Hz  
 Model : FG 781408  
 Memo : PCS 1900 Link;Ch661+Earphone+Adaptor  
 Plane : E2

	Freq	Level	Over	Limit	Read		
	MHz	dBm	Limit	Line	Level	Factor	Remark
			dB	dBm	dBm	dB	
1	33.2	-57.43	-44.43	-13.00	-47.54	-9.89	Peak
2	48.6	-52.77	-39.77	-13.00	-38.50	-14.27	Peak
3	71.6	-47.38	-34.38	-13.00	-35.63	-11.74	Peak
4	733.3	-63.79	-50.79	-13.00	-63.86	0.07	Peak
5	890.8	-61.88	-48.88	-13.00	-63.66	1.79	Peak
6	978.3	-61.19	-48.19	-13.00	-63.68	2.49	Peak
7	1878.0	-43.51			-47.81	4.29	Peak
8	1958.0	-36.98			-41.99	5.01	Peak
9	3758.0	-44.63	-31.63	-13.00	-54.52	9.89	Peak
10 @	5638.0	-32.93	-19.93	-13.00	-49.90	16.97	Peak
11	9398.0	-39.92	-26.92	-13.00	-59.80	19.89	Peak

Remark:

- #7: MS Signal
- #8: BS Signal
- There is no more obvious emission except the listings above.



4.6.5.4 Mode 4

Horizontal Polarization

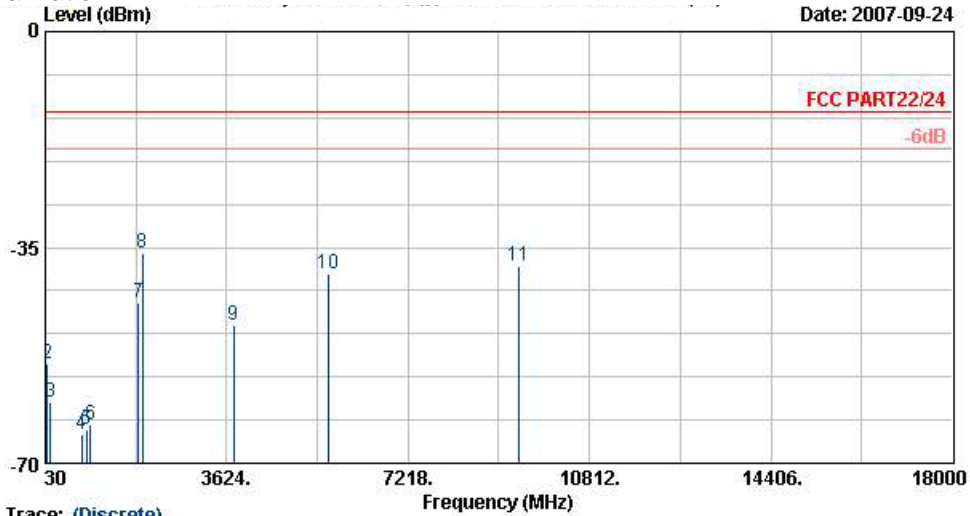

Date: 2007-09-24

Trace: (Discrete)

Site : 08CH06-HY  
 Condition : HF-SPURIOUS-060929 HORIZONTAL  
 EUT : GSM/EDGE 850/900/1800/1900 Smart Phone  
 : with BT, EDR, 802.11g, GFS, FM  
 Power : 120Vac/60Hz  
 Model : FG 781408  
 Memo : PCS 1900 Link;Ch661+Earphone+Adaptor  
 Plane : E2

	Freq	Level	Over	Limit	Read		
	MHz	dBm	Limit	Line	Level	Factor	Remark
			dB	dBm	dBm	dB	
1	33.2	-60.95	-47.95	-13.00	-59.48	-1.47	Peak
2	65.6	-53.85	-40.85	-13.00	-41.48	-12.37	Peak
3	140.4	-60.11	-47.11	-13.00	-47.40	-12.71	Peak
4	745.9	-65.23	-52.23	-13.00	-62.99	-2.25	Peak
5	848.8	-64.59	-51.59	-13.00	-63.37	-1.22	Peak
6	918.8	-63.86	-50.86	-13.00	-63.31	-0.55	Peak
7	1884.0	-44.01			-47.91	3.90	Peak
8 @	1958.0	-36.03			-40.45	4.41	Peak
9	3758.0	-47.65	-34.65	-13.00	-58.06	10.41	Peak
10	5638.0	-39.28	-26.28	-13.00	-57.72	18.45	Peak
11	9398.0	-37.93	-24.93	-13.00	-59.34	21.40	Peak

Remark:

- #7: MS Signal
- #8: BS Signal



Vertical Polarization

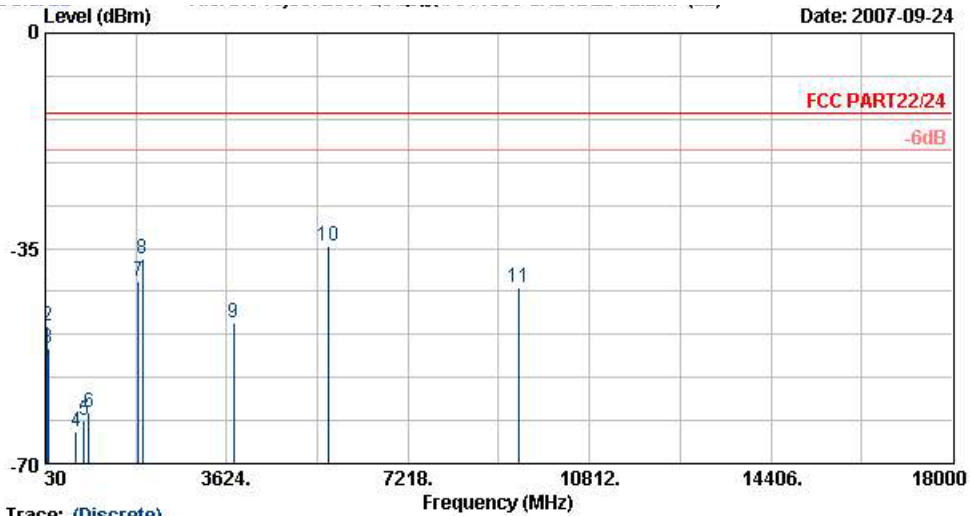

Trace: (Discrete)

Site : 03CHD6-HY  
 Condition : HF-SPURIOUS-060929 VERTICAL  
 EUT : GSM/EDGE 850/900/1800/1900 Smart Phone  
 : with BT, EDR, 802.11g, GFS, FM  
 Power : 120Vac/60Hz  
 Model : FG 781408  
 Memo : PCS 1900 Link;Ch661+Earphone+Adaptor  
 Plane : E2

	Freq	Level	Over	Limit	Read	Factor	Remark
	MHz	dBm	dB	dBm	dBm	dB	
1	31.9	-57.78	-44.78	-13.00	-48.16	-9.62	Peak
2	71.6	-47.68	-34.68	-13.00	-35.94	-11.74	Peak
3	84.5	-51.19	-38.19	-13.00	-41.26	-9.93	Peak
4	633.9	-64.89	-51.89	-13.00	-63.47	-1.42	Peak
5	794.9	-62.98	-49.98	-13.00	-63.97	1.00	Peak
6	901.3	-61.54	-48.54	-13.00	-63.42	1.87	Peak
7	1884.0	-40.27			-44.57	4.29	Peak
8	1958.0	-36.71			-41.71	5.01	Peak
9	3758.0	-47.05	-34.05	-13.00	-56.94	9.89	Peak
10 @	5638.0	-34.60	-21.60	-13.00	-51.57	16.97	Peak
11	9398.0	-41.26	-28.26	-13.00	-61.14	19.89	Peak

Remark:

- #7: MS Signal
- #8: BS Signal
- There is no more obvious emission except the listings above.



4.6.5.5 Mode 5

Horizontal Polarization

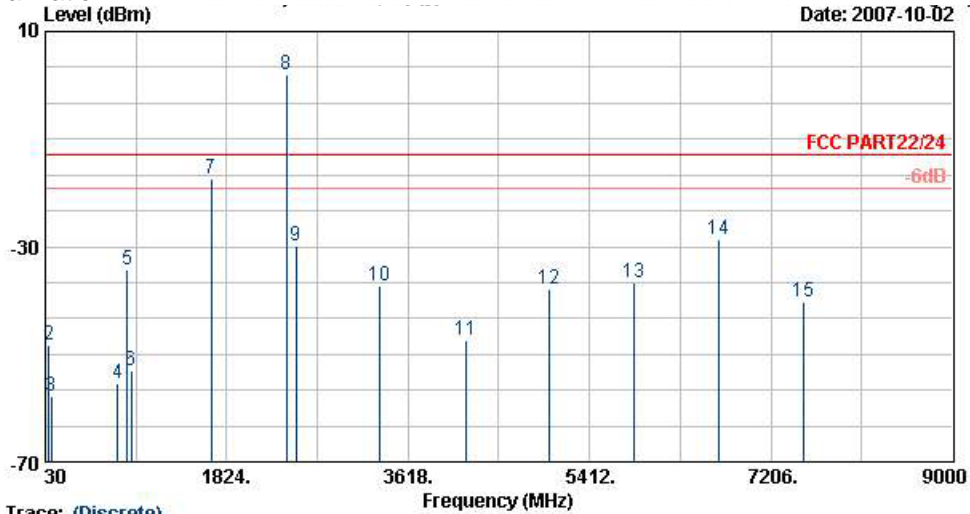

Trace: (Discrete)  
 Site : 03CH06-HV  
 Condition : FCC PART22/24 HF-SPURIOUS-060929 HORIZONTAL  
 EUT : GSM/EDGE 850/900/1800/1900 Smart Phone  
 with BT, EDR, 802.11g, GPS, FM  
 Power : 120Vac/60Hz  
 Model : FG 781408  
 Memo : GSM 850 Link;Ch189 +11g Tx\_Ch01  
 + Earphone + Adaptor  
 Plane : E2

	Freq	Level	Over	Limit	Read		
	MHz	dBm	Limit	Line	Level	Factor	Remark
			dB	dBm	dBm	dB	
1	34.59	-51.33	-38.33	-13.00	-48.64	-2.69	Peak
2	64.83	-48.30	-35.30	-13.00	-35.93	-12.37	Peak
3	91.29	-57.85	-44.85	-13.00	-45.58	-12.27	Peak
4	743.80	-55.31	-42.31	-13.00	-53.04	-2.27	Peak
5	840.40	-34.35			-33.04	-1.31	Peak
6	882.40	-53.12			-52.23	-0.89	Peak
7 !	1674.00	-17.38	-4.38	-13.00	-19.74	2.36	Peak
8 @	2414.00	2.12			-4.20	6.31	Peak
9	2508.00	-29.96	-16.96	-13.00	-36.65	6.69	Peak
10	3344.00	-37.40	-24.40	-13.00	-46.80	9.40	Peak
11	4184.00	-47.38	-34.38	-13.00	-59.36	11.98	Peak
12	5018.00	-38.03	-25.03	-13.00	-54.10	16.07	Peak
13	5854.00	-36.62	-23.62	-13.00	-56.48	19.85	Peak
14	6688.00	-28.59	-15.59	-13.00	-48.77	20.19	Peak
15	7528.00	-40.22	-27.22	-13.00	-61.54	21.31	Peak

Remark:

- #5: MS Signal
- #6: BS Signal
- #8: WLAN Signal



Vertical Polarization

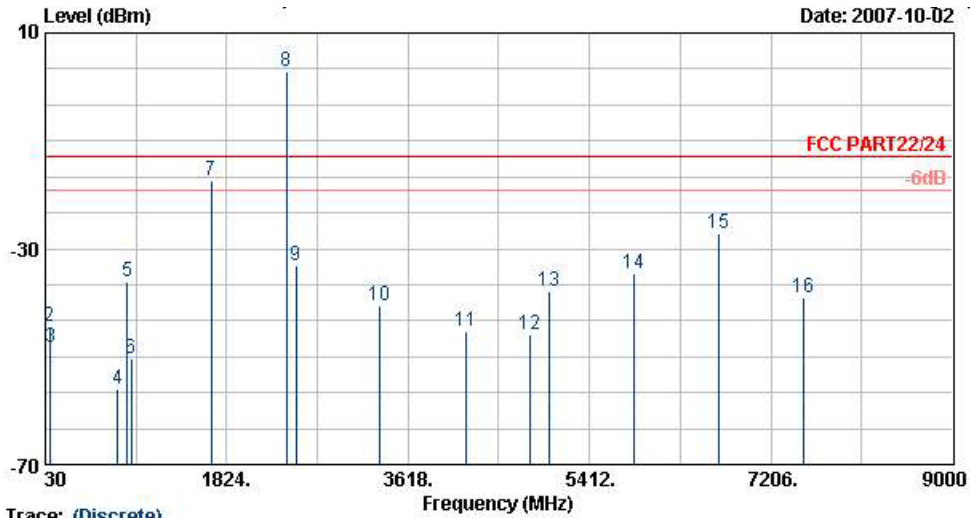

Date: 2007-10-02

Trace: (Discrete)

Site : 08CH06-HY  
 Condition : FCC PART22/24 HF-SPURIOUS-060020 VERTICAL  
 EUT : GSM/EDGE 850/900/1800/1900 Smart Phone  
 with BT, EDR, 802.11g, GPS, FM  
 Power : 120Vac/60Hz  
 Model : FC 781408  
 Memo : GSM 850 Link;Ch189 +11g Tx\_Ch01  
 + Earphone + Adaptor  
 Plane : E2

	Freq	Level	Over	Limit	Read	Factor	Remark
	MHz	dBm	Limit	Line	Level	dB	
			dB	dBm	dBm		
1	35.13	-53.14	-40.14	-13.00	-42.70	-10.44	Peak
2	73.74	-44.50	-31.50	-13.00	-33.04	-11.46	Peak
3	82.38	-48.33	-35.33	-13.00	-38.12	-10.21	Peak
4	743.80	-56.06	-43.06	-13.00	-56.28	0.23	Peak
5	840.40	-35.98			-37.36	1.39	Peak
6	880.30	-50.42			-52.13	1.71	Peak
7 !	1674.00	-17.42	-4.42	-13.00	-19.58	2.16	Peak
8 @	2418.00	2.97			-3.92	6.89	Peak
9	2508.00	-33.02	-20.02	-13.00	-40.20	7.18	Peak
10	3344.00	-40.58	-27.58	-13.00	-49.12	8.55	Peak
11	4184.00	-45.43	-32.43	-13.00	-56.79	11.36	Peak
12	4824.00	-45.90	-32.90	-13.00	-59.83	13.92	Peak
13	5018.00	-37.82	-24.82	-13.00	-52.55	14.74	Peak
14	5854.00	-34.53	-21.53	-13.00	-53.01	18.49	Peak
15	6688.00	-27.21	-14.21	-13.00	-45.90	18.68	Peak
16	7528.00	-39.04	-26.04	-13.00	-58.55	19.51	Peak

Remark:

- #5: MS Signal
- #6: BS Signal
- #8: WLAN Signal
- There is no more obvious emission except the listings above.

## 4.7 Frequency Stability (Temperature Variation)

### 4.7.1 Measurement Instrument

As described in chapter 5 of this test report.

### 4.7.2 Test Procedure

1. The EUT and test equipment were set up as shown on the following section.
2. With all power removed, the temperature was decreased to  $-30^{\circ}\text{C}$  and permitted to stabilize for three hours. Power was applied and the maximum change in frequency was noted within one minute.
3. With power OFF, the temperature was raised in  $10^{\circ}\text{C}$  steps. The sample was permitted to stabilize at each step for at least one-half hour. Power was applied and the maximum frequency change was noted within one minute.
4. The temperature tests were performed for the worst case.
5. Test data was recorded.

### 4.7.3 Test Setup Layout

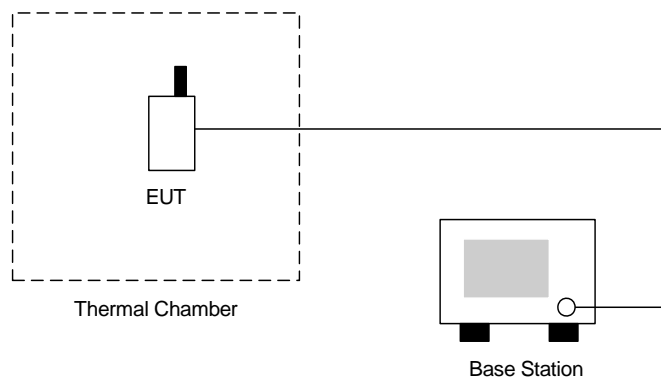



4.7.4 Test Result

• Test Mode : GSM850 (GSM) CH189

Temperature(°C)	Change (Hz)	Change (ppm)	Limit (ppm)	Result
-30	-33	-0.02	2.5	Passed
-20	28	0.03		
-10	-25	-0.03		
0	-24	-0.03		
10	17	0.02		
20	21	0.02		
30	13	0.02		
40	-15	-0.02		
50	-19	-0.02		

• Test Mode : GSM850 (EDGE) CH189

Temperature(°C)	Change (Hz)	Change (ppm)	Limit (ppm)	Result
-30	-16	-0.01	2.5	Passed
-20	18	0.02		
-10	22	0.03		
0	-17	-0.02		
10	10	0.01		
20	12	0.01		
30	-20	-0.02		
40	25	0.03		
50	-19	-0.02		

• Test Mode : PCS1900 (GSM) CH661

Temperature(°C)	Change (Hz)	Change (ppm)	Limit (ppm)	Result
-30	44	0.02	2.5	Passed
-20	-12	-0.01		
-10	15	0.01		
0	-22	-0.01		
10	21	0.01		
20	18	0.01		
30	15	0.01		
40	-20	-0.01		
50	23	0.01		



• Test Mode : PCS1900 (EDGE) CH661

Temperature(°C)	Change (Hz)	Change (ppm)	Limit (ppm)	Result
-30	-30	-0.02	2.5	Passed
-20	22	0.01		
-10	10	0.01		
0	15	0.01		
10	-18	-0.01		
20	-15	-0.01		
30	-17	-0.01		
40	24	0.01		
50	26	0.01		



**4.8 Frequency Stability (Voltage Variation)**

4.8.1 Measurement Instrument

As described in chapter 5 of this test report.

4.8.2 Test Procedure

1. The EUT was placed in a temperature chamber at  $25\pm 5$  °C and connected as the following section.
2. The power supply voltage to the EUT was varied from BEP to 115% of the nominal value measured at the input to the EUT.
3. The variation in frequency was measured for the worst case.

4.8.3 Test Setup Layout

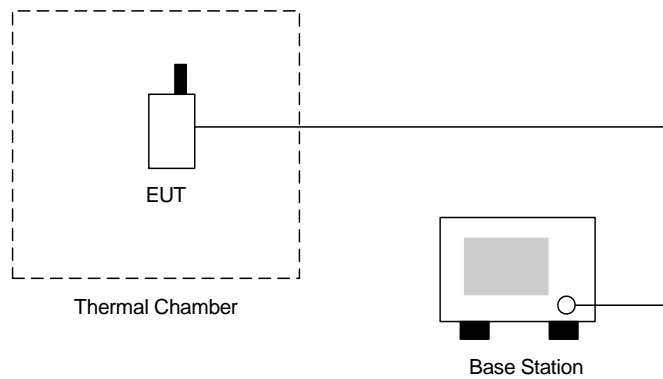

4.8.4 Test Result

- Test Mode : GSM850 (GSM) CH189

Voltage(Volt)	Change (Hz)	Change (ppm)	Limit (ppm)	Result
3.7	16.0	0.02	2.5	Passed
BEP	-22.0	-0.03		
4.2	-20.0	-0.02		

- Test Mode : GSM850 (EDGE) CH189

Voltage(Volt)	Change (Hz)	Change (ppm)	Limit (ppm)	Result
3.7	12.0	0.01	2.5	Passed
BEP	9.0	0.01		
4.2	-15.0	-0.02		



- Test Mode : PCS1900 (GSM) CH661

Voltage(Volt)	Change (Hz)	Change (ppm)	Limit (ppm)	Result
3.7	14.0	0.01	2.5	Passed
BEP	8.0	0.00		
4.2	10.0	0.01		

- Test Mode : PCS1900 (EDGE) CH661

Voltage(Volt)	Change (Hz)	Change (ppm)	Limit (ppm)	Result
3.7	-12.0	-0.01	2.5	Passed
BEP	10.0	0.01		
4.2	11.0	0.01		

Remark:

1. Normal Voltage=3.7V.
2. Battery End Point (BEP)= 3.4 V.



### 5. List of Measurement Equipments

Instrument	Manufacturer	Model No.	Serial No.	Characteristics	Calibration Date	Due Date	Remark
Spectrum Analyzer	Agilent	E4408B	MY44211030	9KHz-26.5GHz	Oct. 05, 2006	Oct. 04, 2007	Radiation (03CH06-HY)
EMI Test Receiver	R&S	ESCS30	100356	9KHz-2.75GHz	Jul. 26, 2007	Jul. 25, 2008	Radiation (03CH06-HY)
Bilog Antenna	SCHAFFNER	CBL6112B	2885	30MHz -2GHz	Nov. 20, 2006	Nov. 19, 2007	Radiation (03CH06-HY)
Double Ridge Horn Antenna	Com-Power	AH118	071025	1G~18G	Jun. 04, 2007	Jun. 03, 2008	Radiation (03CH06-HY)
SHF-EHF Horn	SCHWARZBECK	BBHA 9170	9170-249	14G - 40G	Nov. 20, 2006	Nov. 19, 2008	Radiation (03CH06-HY)
Pre Amplifier	Agilent	8449B	3008A01917	1G - 26.5G	Nov. 15, 2006	Nov. 14, 2007	Radiation (03CH06-HY)
Pre Amplifier	Mini Circuits	ZKL-2	D092004-1	10~2500MHz	Nov. 15, 2006	Nov. 14, 2007	Radiation (03CH06-HY)
Base Station Simulator	R & S	CMU200	106656	WCDMA	Nov. 20, 2006	Nov. 19, 2007	Radiation (03CH06-HY)
Controller	INN-CO	CO2000	N/A	N/A	N/A	N/A	Radiation (03CH06-HY)
Turn Table	INN-CO	DS2000	420/650/00	0 ~ 360 degree	N/A	N/A	Radiation (03CH06-HY)
Antenna Mast	INN-CO	MM3000	114/8000604/L	1 m - 4 m	N/A	N/A	Radiation (03CH06-HY)
Thermal Chamber	Tenyi technology	TTH-D35P	TBN-930701	N/A	Aug. 02, 2007	Aug. 01, 2008	Conduction (TH02-HY)
Spectrum	R&S	FSP40	100055	9KHz~40GHz	Jun. 25, 2007	Jun. 24, 2008	Conduction (TH02-HY)
Bluetooth Test	ANRITSU	MT8852A	6K00003939	N/A	N/A	N/A	Conduction (TH02-HY)
Power Divider	ARRA	5200-1	3871	N/A	Oct. 07, 2006	Oct. 06, 2007	Conduction (TH02-HY)
Dc Power Supply	TOPWARD	3303D	740889	N/A	May 25, 2007	May 24, 2009	Conduction (TH02-HY)
Power Meter	Agilent	E4416A	GB41292344	N/A	Feb. 08, 2007	Feb. 07, 2008	Conduction (TH02-HY)
Power Sensor	Agilent	E9327A	US40441548	N/A	Feb. 08, 2007	Feb. 07, 2008	Conduction (TH02-HY)



## 6. Uncertainty Evaluation

### Uncertainty of Radiated Emission Measurement (30MHz ~ 1000MHz)

Contribution	Uncertainty of $x_i$		$u(x_i)$
	dB	Probability Distribution	
Receiver reading	0.41	Normal(k=2)	0.21
Antenna factor calibration	0.83	Normal(k=2)	0.42
Cable loss calibration	0.25	Normal(k=2)	0.13
Pre Amplifier Gain calibration	0.27	Normal(k=2)	0.14
RCV/SPA specification	2.50	Rectangular	0.72
Antenna Factor Interpolation for Frequency	1.00	Rectangular	0.29
Site imperfection	1.43	Rectangular	0.83
Mismatch	+0.39/-0.41	U-shaped	0.28
<b>Combined standard uncertainty Uc(y)</b>	<b>1.27</b>		
<b>Measuring uncertainty for a level of confidence of 95% U=2Uc(y)</b>	<b>2.54</b>		

### Uncertainty of Radiated Emission Measurement (1GHz ~ 40GHz)

Contribution	Uncertainty of $x_i$		$u(x_i)$	$C_i$	$C_i * u(x_i)$
	dB	Probability Distribution			
Receiver reading	±0.10	Normal(k=1)	0.10	1	0.10
Antenna factor calibration	±1.70	Normal(k=2)	0.85	1	0.85
Cable loss calibration	±0.50	Normal(k=2)	0.25	1	0.25
Receiver Correction	±2.00	Rectangular	1.15	1	1.15
Antenna Factor Directional	±1.50	Rectangular	0.87	1	0.87
Site imperfection	±2.80	Triangular	1.14	1	1.14
Mismatch Receiver VSWR $\Gamma_1 = 0.197$ Antenna VSWR $\Gamma_2 = 0.194$ Uncertainty = $20 \log(1 - \Gamma_1 * \Gamma_2 * \Gamma_3)$	+0.34/-0.35	U-shaped	0.244	1	0.244
<b>Combined standard uncertainty Uc(y)</b>	<b>2.36</b>				
<b>Measuring uncertainty for a level of confidence of 95% U=2Uc(y)</b>	<b>4.72</b>				

END OF TEST REPORT