



A D T

FCC TEST REPORT (PART 24)

REPORT NO.: RF130326C14-1
MODEL NO.: K005
FCC ID: MSQK005
RECEIVED: Mar. 26, 2013
TESTED: Apr. 15, 2013 ~ Apr. 21, 2013
ISSUED: May 02, 2013

APPLICANT: ASUSTek COMPUTER INC.

ADDRESS: 4F., No. 150, LI-TE Rd., PEITOU, TAIPEI 112, TAIWAN

ISSUED BY: Bureau Veritas Consumer Products Services
(H.K.) Ltd., Taoyuan Branch

LAB ADDRESS: No. 47, 14th Ling, Chia Pau Vil., Lin Kou Dist., New
Taipei City, Taiwan (R.O.C.)

TEST LOCATION: No. 19, Hwa Ya 2nd Rd, Wen Hwa Tsuen, Kwei
Shan Hsiang, Taoyuan Hsien 333, Taiwan, R.O.C.

This report should not be used by the client to claim
product certification, approval, or endorsement by TAF or
any government agencies.



This report is for your exclusive use. Any copying or replication of this report to or for any other person or entity, or use of our name or trademark, is permitted only with our prior written permission. This report sets forth our findings solely with respect to the test samples identified herein. The results set forth in this report are not indicative or representative of the quality or characteristics of the lot from which a test sample was taken or any similar or identical product unless specifically and expressly noted. Our report includes all of the tests requested by you and the results thereof based upon the information that you provided to us. You have 60 days from date of issuance of this report to notify us of any material error or omission caused by our negligence, provided, however, that such notice shall be in writing and shall specifically address the issue you wish to raise. A failure to raise such issue within the prescribed time shall constitute your unqualified acceptance of the completeness of this report, the tests conducted and the correctness of the report contents. Unless specific mention, the uncertainty of measurement has been explicitly taken into account to declare the compliance or non-compliance to the specification



TABLE OF CONTENTS

RELEASE CONTROL RECORD.....	4
1 CERTIFICATION	5
2 SUMMARY OF TEST RESULTS	6
2.1 MEASUREMENT UNCERTAINTY	6
2.2 TEST SITE AND INSTRUMENTS	7
3 GENERAL INFORMATION.....	8
3.1 GENERAL DESCRIPTION OF EUT.....	8
3.2 CONFIGURATION OF SYSTEM UNDER TEST	10
3.3 DESCRIPTION OF SUPPORT UNITS	10
3.4 TEST ITEM AND TEST CONFIGURATION	11
3.5 EUT OPERATING CONDITIONS	14
3.6 GENERAL DESCRIPTION OF APPLIED STANDARDS	14
4 TEST TYPES AND RESULTS.....	15
4.1 OUTPUT POWER MEASUREMENT	15
4.1.1 LIMITS OF OUTPUT POWER MEASUREMENT	15
4.1.2 TEST PROCEDURES	15
4.1.3 TEST SETUP	16
4.1.4 TEST RESULTS	17
4.2 FREQUENCY STABILITY MEASUREMENT	31
4.2.1 LIMITS OF FREQUENCY STABILITY MEASUREMENT	31
4.2.2 TEST PROCEDURE	31
4.2.3 TEST SETUP	31
4.2.4 TEST RESULTS	32
4.3 OCCUPIED BANDWIDTH MEASUREMENT	33
4.3.1 TEST PROCEDURES	33
4.3.2 TEST SETUP	33
4.3.3 TEST RESULTS	34
4.4 PEAK TO AVERAGE RATIO	38
4.4.1 LIMITS OF PEAK TO AVERAGE RATIO MEASUREMENT	38
4.4.2 TEST SETUP	38
4.4.3 TEST PROCEDURES	38
4.4.4 TEST RESULTS	39
4.5 BAND EDGE MEASUREMENT	43
4.5.1 LIMITS OF BAND EDGE MEASUREMENT	43
4.5.2 TEST SETUP	43
4.5.3 TEST PROCEDURES	43
4.5.4 TEST RESULTS	44
4.6 CONDUCTED SPURIOUS EMISSIONS.....	51
4.6.1 LIMITS OF CONDUCTED SPURIOUS EMISSIONS MEASUREMENT	51
4.6.2 TEST PROCEDURE	51
4.6.3 TEST SETUP	51
4.6.4 TEST RESULTS	52
4.7 RADIATED EMISSION MEASUREMENT	54
4.7.1 LIMITS OF RADIATED EMISSION MEASUREMENT	54
4.7.2 TEST PROCEDURES	54
4.7.3 DEVIATION FROM TEST STANDARD	54
4.7.4 TEST SETUP	55
4.7.5 TEST RESULTS	56
5 PHOTOGRAPHS OF THE TEST CONFIGURATION.....	74



A D T

6	INFORMATION ON THE TESTING LABORATORIES.....	75
7	APPENDIX A – MODIFICATIONS RECORDERS FOR ENGINEERING CHANGES TO THE EUT BY THE LAB.....	76



A D T

RELEASE CONTROL RECORD

ISSUE NO.	REASON FOR CHANGE	DATE ISSUED
RF130326C14-1	Original release	May 02, 2013



1 CERTIFICATION

PRODUCT: ASUS Tablet

MODEL: K005

BRAND: ASUS

APPLICANT: ASUSTek COMPUTER INC.

TESTED: Apr. 15, 2013 ~ Apr. 21, 2013

TEST SAMPLE: Production Unit

STANDARDS: FCC Part 24, Subpart E

The above equipment (model: K005) has been tested by **Bureau Veritas Consumer Products Services (H.K.) Ltd., Taoyuan Branch**, and found compliance with the requirement of the above standards. The test record, data evaluation & Equipment Under Test (EUT) configurations represented herein are true and accurate accounts of the measurements of the sample's EMC characteristics under the conditions specified in this report.

PREPARED BY : Vera Huang , **DATE** : May 02, 2013
Vera Huang / Specialist

APPROVED BY : Sam chen , **DATE** : May 02, 2013
Sam Chen / Assistant Manager



A D T

2 SUMMARY OF TEST RESULTS

The EUT has been tested according to the following specifications:

APPLIED STANDARD: FCC Part 24 & Part 2			
STANDARD SECTION	TEST TYPE	RESULT	REMARK
2.1046 24.232	Equivalent isotropically radiated power	PASS	Meet the requirement of limit.
2.1055 24.235	Frequency Stability	PASS	Meet the requirement of limit.
2.1049 24.238(b)	Occupied Bandwidth	PASS	Meet the requirement of limit.
24.232(d)	Peak to average ratio	PASS	Meet the requirement of limit.
24.238(b)	Band Edge Measurements	PASS	Meet the requirement of limit.
2.1051 24.238	Conducted Spurious Emissions	PASS	Meet the requirement of limit.
2.1053 24.238	Radiated Spurious Emissions	PASS	Meet the requirement of limit. Minimum passing margin is -14.47dB at 5659.80MHz.

2.1 MEASUREMENT UNCERTAINTY

Where relevant, the following measurement uncertainty levels have been estimated for tests performed on the EUT as specified in CISPR 16-4-2:

MEASUREMENT	FREQUENCY	UNCERTAINTY
Conducted emissions	150kHz~30MHz	2.44 dB
Radiated emissions	30MHz ~ 200MHz	2.93 dB
	200MHz ~1000MHz	2.95 dB
	1GHz ~ 18GHz	2.26 dB
	18GHz ~ 40GHz	1.94 dB

This uncertainty represents an expanded uncertainty expressed at approximately the 95% confidence level using a coverage factor of k=2.



2.2 TEST SITE AND INSTRUMENTS

DESCRIPTION & MANUFACTURER	MODEL NO.	SERIAL NO.	DATE OF CALIBRATION	DUE DATE OF CALIBRATION
Test Receiver ROHDE & SCHWARZ	ESCI	100424	Aug. 21, 2012	Aug. 20, 2013
Spectrum Analyzer ROHDE & SCHWARZ	FSU43	101261	Dec. 17, 2012	Dec. 16, 2013
BILOG Antenna SCHWARZBECK	VULB9168	9168-472	Mar. 25, 2013	Mar. 24, 2014
HORN Antenna SCHWARZBECK	BBHA 9120 D	9120D-969	Jan. 07, 2013	Jan. 06, 2014
HORN Antenna SCHWARZBECK	BBHA 9170	9170-480	Dec. 25, 2012	Dec. 24, 2013
Loop Antenna	HFH2-Z2	100070	Jan. 31, 2012	Jan. 30, 2014
Preamplifier EMCI	EMC 012645	980115	Dec. 28, 2012	Dec. 27, 2013
Preamplifier EMCI	EMC 184045	980116	Dec. 28, 2012	Dec. 27, 2013
Preamplifier EMCI	EMC 330H	980112	Dec. 28, 2012	Dec. 27, 2013
RF signal cable HUBER+SUHNNER	SUCOFLEX 104	309219/4	Oct. 19, 2012	Oct. 18, 2013
RF signal cable HUBER+SUHNNER	SUCOFLEX 104	250130/4	Oct. 19, 2012	Oct. 18, 2013
RF signal cable Worken	RG-213	NA	Dec. 29, 2012	Dec. 28, 2013
Software	E3 6.120103	NA	NA	NA
Antenna Tower MF	MFA-440H	NA	NA	NA
Turn Table MF	MFT-201SS	NA	NA	NA
Antenna Tower & Turn Table Controller MF	MF-7802	NA	NA	NA

- NOTE:** 1. The calibration interval of the above test instruments is 12 months and the calibrations are traceable to NML/ROC and NIST/USA.
2. The test was performed in HwaYa Chamber 10.
3. The horn antenna and HP preamplifier (model: 8449B) are used only for the measurement of emission frequency above 1GHz if tested.
4. The FCC Site Registration No. is 690701.
5. The IC Site Registration No. is IC 7450F-10.



A D T

3 GENERAL INFORMATION

3.1 GENERAL DESCRIPTION OF EUT

EUT	ASUS Tablet	
MODEL NO.	K005	
POWER SUPPLY	5.0Vdc (adapter or host equipment) 3.7Vdc (battery)	
MODULATION TYPE	GPRS	GMSK
	EDGE	8PSK
	WCDMA	BPSK
	LTE	QPSK, 16QAM
FREQUENCY RANGE	GPRS/EDGE	1850.2MHz ~ 1909.8MHz
	WCDMA	1852.4MHz ~ 1907.6MHz
	LTE (Channel Bandwidth: 1.4MHz)	1850.7MHz ~ 1909.3MHz
	LTE (Channel Bandwidth: 3MHz)	1851.5MHz ~ 1908.5MHz
	LTE (Channel Bandwidth: 5MHz)	1852.5MHz ~ 1907.5MHz
	LTE (Channel Bandwidth: 10MHz)	1855MHz ~ 1905MHz
	LTE (Channel Bandwidth: 15MHz)	1857.5MHz ~ 1902.5MHz
	LTE (Channel Bandwidth: 20MHz)	1860MHz ~ 1900MHz
MAX. EIRP POWER	GPRS	1253.14mW
	EDGE	452.90mW
	WCDMA	221.31mW
	LTE (Channel Bandwidth: 1.4MHz)	245.47mW
	LTE (Channel Bandwidth: 3MHz)	246.04mW
	LTE (Channel Bandwidth: 5MHz)	222.84mW
	LTE (Channel Bandwidth: 10MHz)	247.74mW
	LTE (Channel Bandwidth: 15MHz)	238.78mW
EMISSION DESIGNATOR	GPRS	245KGXW
	EDGE	250KG7W
	WCDMA	4M18F9W
	LTE (Channel Bandwidth: 1.4MHz)	1M09W7D
	LTE (Channel Bandwidth: 3MHz)	2M68W7D
	LTE (Channel Bandwidth: 5MHz)	4M49G7D
	LTE (Channel Bandwidth: 10MHz)	8M94W7D
	LTE (Channel Bandwidth: 15MHz)	13M4G7D
LTE (Channel Bandwidth: 20MHz)	17M8W7D	



A D T

MULTI-SLOTS CLASS	10
WCDMA RELEASE VERSION	8
LTE CATEGORY	3
ANTENNA TYPE	Fixed Internal Antenna
I/O PORTS	Refer to users' manual
DATA CABLE	Refer to NOTE as below
ACCESSORY DEVICES	Refer to NOTE as below

NOTE:

1. The EUT has following accessories.

ITEM	BRAND	MODEL	DESCRIPTION
AC Adapter 1	ASUS	AD83531	Input: 100-240Vac, 50/60Hz, 0.3A Output: 5Vdc, 2A
AC Adapter 2	ASUS	W12-010N3A	Input: 100-240Vac, 50/60Hz, 0.3A Output: 5Vdc, 2A
Battery	SMP (cell SDI)	C12P1302	Rating: 3.7Vdc, 6560mAh / 25Wh
USB Cable	ASUS	AA757600	0.9m shielded cable without ferrite core
LCD Panel	AUO	AUO/B101UAN01.7_ H/W 1A	--
Video Camera (Front)	Liteon	LITEON/10P2SF130K	--
Video Camera (Rear)	Liteon	LITEON/12P2BA540	--
WWAN Module	Qualcomm	MDM-9215M	--
WLAN Module	Qualcomm	WCN-3660	--
CPU	Qualcomm	APQ-8064	1.7GHz, 1067 pins
Mainboard	Asus	ME302KL	--

2. The above EUT information was declared by manufacturer and for more detailed features description, please refer to the manufacturer's specifications or User's Manual.

3.2 CONFIGURATION OF SYSTEM UNDER TEST

FOR RADIATION EMISSION TEST

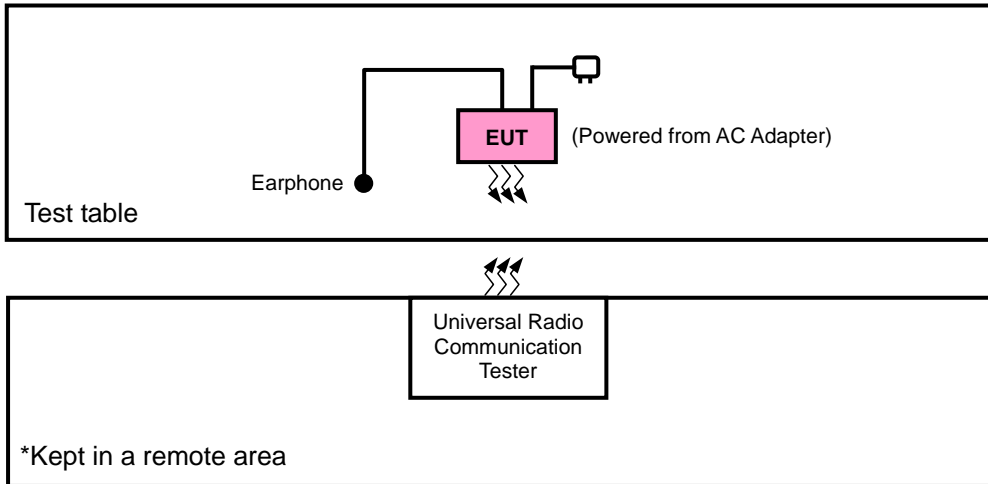

FOR E.R.P. TEST

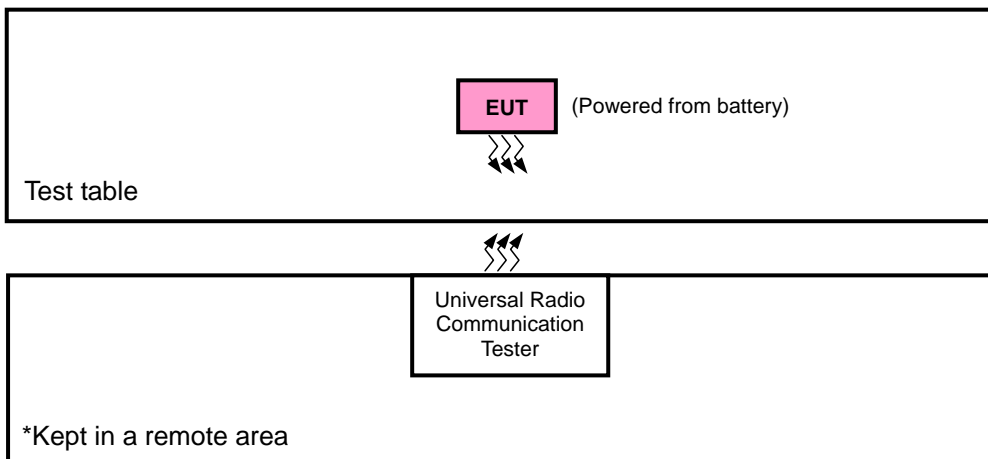

3.3 DESCRIPTION OF SUPPORT UNITS

The EUT has been tested as an independent unit together with other necessary accessories or support units. The following support units or accessories were used to form a representative test configuration during the tests.

NO.	PRODUCT	BRAND	MODEL NO.	SERIAL NO.	FCC ID
1	Earphone	Acon	CW-010M.V	N/A	N/A

NO.	SIGNAL CABLE DESCRIPTION OF THE ABOVE SUPPORT UNITS
1	N/A

NOTE: All power cords of the above support units are non shielded (1.8m).



3.4 TEST ITEM AND TEST CONFIGURATION

Pre-Scan has been conducted to determine the worst-case mode from all possible combinations between available modulations, data rates, XYZ axis and antenna ports. The worst case was found as listed below for radiated emission. Following channel(s) was (were) selected for the final test as listed below:

	BAND	AXIS FOR RADIATED EMISSION
EIRP	GPRS / EDGE / WCDMA	Y
	LTE	X
RADIATED EMISSION	GPRS / EDGE / WCDMA	Y
	LTE	Y

GSM MODE

TEST ITEM	AVAILABLE CHANNEL	TESTED CHANNEL	MODE
EIRP	512 to 810	512, 661, 810	GPRS, EDGE
FREQUENCY STABILITY	512 to 810	661	GPRS, EDGE
OCCUPIED BANDWIDTH	512 to 810	512, 661, 810	GPRS, EDGE
PEAK TO AVERAGE RATIO	512 to 810	512, 661, 810	GPRS, EDGE
BAND EDGE	512 to 810	512, 810	GPRS, EDGE
CONDCUDED EMISSION	512 to 810	661	GPRS, EDGE
RADIATED EMISSION	512 to 810	661	GPRS, EDGE

WCDMA MODE

TEST ITEM	AVAILABLE CHANNEL	TESTED CHANNEL	MODE
EIRP	9262 to 9538	9262, 9400, 9538	WCDMA
FREQUENCY STABILITY	9262 to 9538	9400	WCDMA
OCCUPIED BANDWIDTH	9262 to 9538	9262, 9400, 9538	WCDMA
PEAK TO AVERAGE RATIO	9262 to 9538	9262, 9400, 9538	WCDMA
BAND EDGE	9262 to 9538	9262, 9538	WCDMA
CONDCUDED EMISSION	9262 to 9538	9400	WCDMA
RADIATED EMISSION	9262 to 9538	9400	WCDMA



LTE BAND 2 MODE

TEST ITEM	AVAILABLE CHANNEL	TESTED CHANNEL	CHANNEL BANDWIDTH	MODULATION	MODE
EIRP	18607 to 19193	18607, 18900, 19193	1.4MHz	QPSK, 16QAM	1 RB / 5 RB Offset
	18615 to 19185	18615, 18900, 19185	3MHz	QPSK, 16QAM	1 RB / 14 RB Offset
	18625 to 19175	18625, 18900, 19175	5MHz	QPSK, 16QAM	1 RB / 24 RB Offset
	18650 to 19150	18650, 18900, 19150	10MHz	QPSK, 16QAM	1 RB / 49 RB Offset
	18675 to 19125	18675, 18900, 19125	15MHz	QPSK, 16QAM	1 RB / 74 RB Offset
	18700 to 19100	18700, 18900, 19100	20MHz	QPSK, 16QAM	1 RB / 99 RB Offset
FREQUENCY STABILITY	18607 to 19193	18900	1.4MHz	QPSK	1 RB / 5 RB Offset
	18615 to 19185	18900	3MHz	QPSK	1 RB / 14 RB Offset
	18625 to 19175	18900	5MHz	QPSK	1 RB / 24 RB Offset
	18650 to 19150	18900	10MHz	QPSK	1 RB / 49 RB Offset
	18675 to 19125	18900	15MHz	QPSK	1 RB / 74 RB Offset
	18700 to 19100	18900	20MHz	QPSK	1 RB / 99 RB Offset
OCCUPIED BANDWIDTH	18607 to 19193	18607, 18900, 19193	1.4MHz	QPSK, 16QAM	6 RB / 0 RB Offset
	18615 to 19185	18615, 18900, 19185	3MHz	QPSK, 16QAM	15 RB / 0 RB Offset
	18625 to 19175	18625, 18900, 19175	5MHz	QPSK, 16QAM	25 RB / 0 RB Offset
	18650 to 19150	18650, 18900, 19150	10MHz	QPSK, 16QAM	50 RB / 0 RB Offset
	18675 to 19125	18675, 18900, 19125	15MHz	QPSK, 16QAM	75 RB / 0 RB Offset
	18700 to 19100	18700, 18900, 19100	20MHz	QPSK, 16QAM	100 RB / 0 RB Offset
PEAK TO AVERAGE RATIO	18607 to 19193	18607, 18900, 19193	1.4MHz	QPSK	1 RB / 5 RB Offset
				16QAM	1 RB / 0 RB Offset
	18615 to 19185	18615, 18900, 19185	3MHz	QPSK, 16QAM	1 RB / 14 RB Offset
	18625 to 19175	18625, 18900, 19175	5MHz	QPSK, 16QAM	1 RB / 24 RB Offset
	18650 to 19150	18650, 18900, 19150	10MHz	QPSK, 16QAM	1 RB / 24 RB Offset
	18675 to 19125	18675, 18900, 19125	15MHz	QPSK, 16QAM	1 RB / 74 RB Offset
18700 to 19100	18700, 18900, 19100	20MHz	QPSK, 16QAM	1 RB / 99 RB Offset	
BAND EDGE	18607 to 19193	18607	1.4MHz	QPSK	1 RB / 0 RB Offset
					6 RB / 0 RB Offset
		19193	1.4MHz	QPSK	1 RB / 5 RB Offset
					6 RB / 0 RB Offset
	18615 to 19185	18615	3MHz	QPSK	1 RB / 0 RB Offset
					15 RB / 0 RB Offset
		19185	3MHz	QPSK	1 RB / 14 RB Offset
					15 RB / 0 RB Offset
	18625 to 19175	18625	5MHz	QPSK	1 RB / 0 RB Offset
					25 RB / 0 RB Offset
		19175	5MHz	QPSK	1 RB / 24 RB Offset
					25 RB / 0 RB Offset
18650 to 19150	18650	10MHz	QPSK	1 RB / 0 RB Offset	
				50 RB / 0 RB Offset	
	19150	10MHz	QPSK	1 RB / 49 RB Offset	
				50 RB / 0 RB Offset	



A D T

TEST ITEM	AVAILABLE CHANNEL	TESTED CHANNEL	CHANNEL BANDWIDTH	MODULATION	MODE
BAND EDGE	18675 to 19125	18675	15MHz	QPSK	1 RB / 0 RB Offset
					75 RB / 0 RB Offset
	18700 to 19100	19125	15MHz	QPSK	1 RB / 74 RB Offset
					75 RB / 0 RB Offset
		18700	20MHz	QPSK	1 RB / 0 RB Offset
					100 RB / 0 RB Offset
CONDCUDED EMISSION	18607 to 19193	18900	1.4MHz	QPSK	1 RB / 5 RB Offset
	18615 to 19185	18900	3MHz	QPSK	1 RB / 14 RB Offset
	18625 to 19175	18900	5MHz	QPSK	1 RB / 24 RB Offset
	18650 to 19150	18900	10MHz	QPSK	1 RB / 24 RB Offset
	18675 to 19125	18900	15MHz	QPSK	1 RB / 74 RB Offset
	18700 to 19100	18900	20MHz	QPSK	1 RB / 99 RB Offset
RADIATED EMISSION	18607 to 19193	18900	1.4MHz	QPSK	1 RB / 5 RB Offset
	18615 to 19185	18900	3MHz	QPSK	1 RB / 14 RB Offset
	18625 to 19175	18900	5MHz	QPSK	1 RB / 24 RB Offset
	18650 to 19150	18900	10MHz	QPSK	1 RB / 49 RB Offset
	18675 to 19125	18900	15MHz	QPSK	1 RB / 74 RB Offset
	18700 to 19100	18900	20MHz	QPSK	1 RB / 99 RB Offset

Note: This device was tested under all bandwidths, RB configurations and modulations. The worst case were found in QPSK modulation.

TEST CONDITION:

TEST ITEM	ENVIRONMENTAL CONDITIONS	INPUT POWER	TESTED BY
EIRP	25deg. C, 59%RH	3.7Vdc	Howard Kao
FREQUENCY STABILITY	25deg. C, 59%RH	3.7Vdc	Howard Kao
OCCUPIED BANDWIDTH	25deg. C, 59%RH	3.7Vdc	Howard Kao
BAND EDGE	25deg. C, 59%RH	3.7Vdc	Howard Kao
CONDCUDED EMISSION	25deg. C, 59%RH	3.7Vdc	Howard Kao
RADIATED EMISSION	25deg. C, 65%RH	120Vac, 60Hz	Johnson Liao

3.5 EUT OPERATING CONDITIONS

The EUT makes a call to the communication simulator. The communication simulator station system controlled a EUT to export maximum output power under transmission mode and specific channel frequency

3.6 GENERAL DESCRIPTION OF APPLIED STANDARDS

The EUT is a RF product. According to the specifications of the manufacturer, it must comply with the requirements of the following standards:

FCC 47 CFR Part 2

FCC 47 CFR Part 24

ANSI/TIA/EIA-603-C 2004

NOTE: All test items have been performed and recorded as per the above standards.

4 TEST TYPES AND RESULTS

4.1 OUTPUT POWER MEASUREMENT

4.1.1 LIMITS OF OUTPUT POWER MEASUREMENT

Mobile and portable stations are limited to 2 watts EIRP

4.1.2 TEST PROCEDURES

EIRP / ERP MEASUREMENT:

- a. All measurements were done at low, middle and high operational frequency range. RBW and VBW is 1MHz for GSM, GPRS & EDGE, 5MHz for WCDMA and CDMA mode.
- b. Substitution method is used for E.I.R.P measurement. In the semi-anechoic chamber, EUT placed on the 0.8m height of Turn Table, rotated the table around 360 degrees to search the maximum radiation power and receiver antenna shall be rotated vertical and horizontal polarization and moved height from 1m to 4m to find the maximum polar radiated power. The “Read Value” is the spectrum reading the maximum power value.
- c. The substitution horn antenna is substituted for EUT at the same position and signals generator export the CW signal to the substitution antenna via a tx cable. Rotated the Turn Table and moved receiving antenna to find the maximum radiation power. Adjust output power level of S.G to get a Value of spectrum reading equal to “Read Value” of step b. Record the power level of S.G
- d. $EIRP = \text{Output power level of S.G} - \text{TX cable loss} + \text{Antenna gain of substitution horn.}$
 $E.R.P \text{ power can be calculated form E.I.R.P power by subtracting the gain of dipole, } E.R.P \text{ power} = E.I.R.P \text{ power} - 2.15\text{dBi.}$

CONDUCTED POWER MEASUREMENT:

The EUT was set up for the maximum power with GSM, GPRS, EDGE, WCDMA & CDMA link data modulation and link up with simulator. Set the EUT to transmit under low, middle and high channel and record the power level shown on simulator.

4.1.3 TEST SETUP

EIRP / ERP MEASUREMENT:

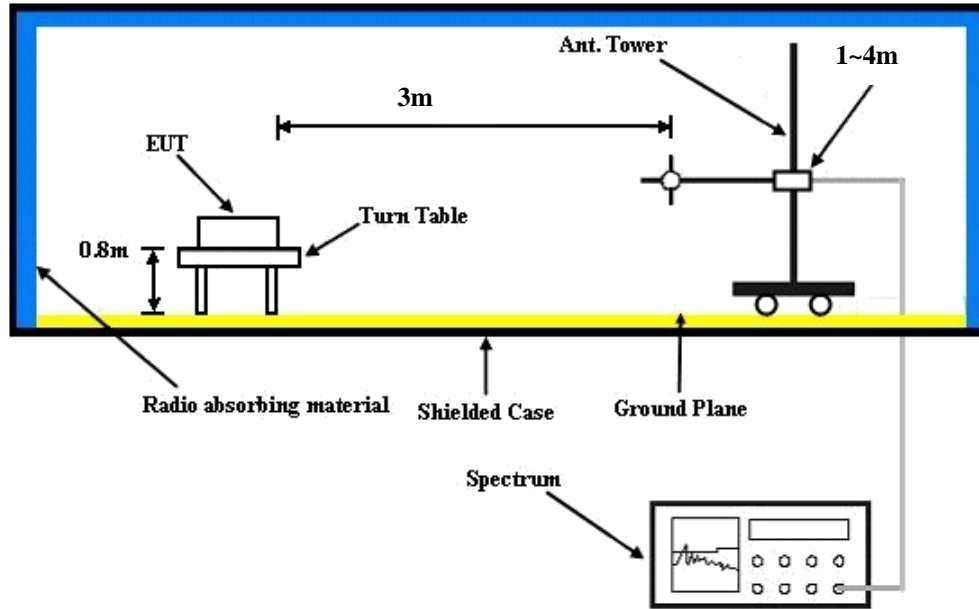

For the actual test configuration, please refer to the attached file (Test Setup Photo).

CONDUCTED POWER MEASUREMENT:

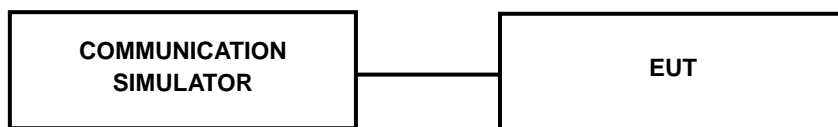

For the actual test configuration, please refer to the attached file (Test Setup Photo).



A D T

4.1.4 TEST RESULTS

CONDUCTED OUTPUT POWER (dBm)

Band	GPRS1900		
Channel	512	661	810
Frequency (MHz)	1850.2	1880.0	1909.8
GPRS 8 (GMSK, 1 slot)	29.79	29.99	30.19
GPRS 10 (GMSK, 2 slot)	29.66	29.82	29.91
EDGE 8 (GMSK, 1 Uplink)	29.76	29.70	30.12
EDGE 10 (GMSK, 2 Uplink)	29.65	29.52	29.89
EDGE 8 (8PSK, 1 Uplink)	25.90	25.90	26.08
EDGE 10 (8PSK, 2 Uplink)	25.73	25.70	25.84

Band	WCDMA II		
Channel	9262	9400	9538
Frequency (MHz)	1852.4	1880.0	1907.6
RMC 12.2K	22.83	22.97	22.65
HSDPA Subtest-1	22.05	22.19	21.87
HSDPA Subtest-2	22.03	22.17	21.85
HSDPA Subtest-3	21.23	21.37	21.05
HSDPA Subtest-4	21.54	21.68	21.36
HSUPA Subtest-1	20.55	20.69	20.37
HSUPA Subtest-2	20.87	21.05	20.78
HSUPA Subtest-3	20.14	20.28	19.96
HSUPA Subtest-4	21.48	21.59	21.29
HSUPA Subtest-5	19.63	19.77	19.45



A D T

LTE Band 2								
BW	Modulation	CH	Frequency	RB	RB Offset	MPR	Target	Measured
			(MHz)				Power	Power
1.4 MHz	QPSK	18607	1850.7	1	0	0	23.6	22.91
		18900	1880	1	0	0	23.6	23.17
		19193	1909.3	1	0	0	23.6	23.2
		18607	1850.7	1	2	0	23.6	22.64
		18900	1880	1	2	0	23.6	22.9
		19193	1909.3	1	2	0	23.6	22.93
		18607	1850.7	1	5	0	23.6	23.12
		18900	1880	1	5	0	23.6	23.38
		19193	1909.3	1	5	0	23.6	23.41
		18607	1850.7	3	0	0	23.6	22.72
		18900	1880	3	0	0	23.6	22.98
		19193	1909.3	3	0	0	23.6	23.01
		18607	1850.7	3	1	0	23.6	22.7
		18900	1880	3	1	0	23.6	22.96
		19193	1909.3	3	1	0	23.6	22.99
		18607	1850.7	3	3	0	23.6	22.69
		18900	1880	3	3	0	23.6	22.95
		19193	1909.3	3	3	0	23.6	22.98
	18607	1850.7	6	0	1	23.6	21.87	
	18900	1880	6	0	1	23.6	22.13	
	19193	1909.3	6	0	1	23.6	22.16	
	18607	1850.7	1	0	1	23.6	21.91	
	18900	1880	1	0	1	23.6	22.13	
	19193	1909.3	1	0	1	23.6	22.19	
	18607	1850.7	1	2	1	23.6	21.69	
	18900	1880	1	2	1	23.6	21.95	
	19193	1909.3	1	2	1	23.6	21.98	
	18607	1850.7	1	5	1	23.6	22.15	
	18900	1880	1	5	1	23.6	22.11	
	19193	1909.3	1	5	1	23.6	22.14	
	18607	1850.7	3	0	1	23.6	21.69	
	18900	1880	3	0	1	23.6	21.95	
	19193	1909.3	3	0	1	23.6	21.98	
	18607	1850.7	3	1	1	23.6	22.1	
	18900	1880	3	1	1	23.6	21.96	
	19193	1909.3	3	1	1	23.6	21.99	
18607	1850.7	3	3	1	23.6	21.69		
18900	1880	3	3	1	23.6	21.95		
19193	1909.3	3	3	1	23.6	21.98		
18607	1850.7	6	0	2	23.6	20.67		
18900	1880	6	0	2	23.6	20.93		
19193	1909.3	6	0	2	23.6	20.96		



A D T

LTE Band 2								
BW	Modulation	CH	Frequency	RB	RB Offset	MPR	Target	Measured
			(MHz)				Power	Power
3MHz	QPSK	18615	1851.5	1	0	0	23.6	22.94
		18900	1880	1	0	0	23.6	23.2
		19185	1908.5	1	0	0	23.6	23.23
		18615	1851.5	1	7	0	23.6	22.67
		18900	1880	1	7	0	23.6	22.93
		19185	1908.5	1	7	0	23.6	22.96
		18615	1851.5	1	14	0	23.6	23.15
		18900	1880	1	14	0	23.6	23.41
		19185	1908.5	1	14	0	23.6	23.44
		18615	1851.5	8	0	1	23.6	21.65
		18900	1880	8	0	1	23.6	21.91
		19185	1908.5	8	0	1	23.6	21.94
		18615	1851.5	8	3	1	23.6	21.63
		18900	1880	8	3	1	23.6	21.89
		19185	1908.5	8	3	1	23.6	21.92
		18615	1851.5	8	7	1	23.6	21.62
		18900	1880	8	7	1	23.6	21.88
		19185	1908.5	8	7	1	23.6	21.91
	18615	1851.5	15	0	1	23.6	21.9	
	18900	1880	15	0	1	23.6	22.16	
	19185	1908.5	15	0	1	23.6	22.19	
	18615	1851.5	1	0	1	23.6	21.94	
	18900	1880	1	0	1	23.6	22.16	
	19185	1908.5	1	0	1	23.6	22.22	
	18615	1851.5	1	7	1	23.6	21.62	
	18900	1880	1	7	1	23.6	21.88	
	19185	1908.5	1	7	1	23.6	21.91	
	18615	1851.5	1	14	1	23.6	22.38	
	18900	1880	1	14	1	23.6	22.64	
	19185	1908.5	1	14	1	23.6	22.67	
	18615	1851.5	8	0	2	23.6	20.62	
	18900	1880	8	0	2	23.6	20.88	
	19185	1908.5	8	0	2	23.6	20.91	
	18615	1851.5	8	3	2	23.6	21.63	
	18900	1880	8	3	2	23.6	20.89	
	19185	1908.5	8	3	2	23.6	20.92	
18615	1851.5	8	7	2	23.6	20.62		
18900	1880	8	7	2	23.6	20.88		
19185	1908.5	8	7	2	23.6	20.91		
18615	1851.5	15	0	2	23.6	20.7		
18900	1880	15	0	2	23.6	20.96		
19185	1908.5	15	0	2	23.6	20.99		



A D T

LTE Band 2								
BW	Modulation	CH	Frequency	RB	RB Offset	MPR	Target	Measured
			(MHz)				Power	Power
5 MHz	QPSK	18625	1852.5	1	0	0	23.6	22.97
		18900	1880	1	0	0	23.6	23.23
		19175	1907.5	1	0	0	23.6	23.26
		18625	1852.5	1	12	0	23.6	22.7
		18900	1880	1	12	0	23.6	22.96
		19175	1907.5	1	12	0	23.6	22.99
		18625	1852.5	1	24	0	23.6	23.18
		18900	1880	1	24	0	23.6	23.44
		19175	1907.5	1	24	0	23.6	23.47
		18625	1852.5	12	0	1	23.6	21.62
		18900	1880	12	0	1	23.6	21.88
		19175	1907.5	12	0	1	23.6	21.91
		18625	1852.5	12	6	1	23.6	21.61
		18900	1880	12	6	1	23.6	21.87
		19175	1907.5	12	6	1	23.6	21.9
		18625	1852.5	12	13	1	23.6	21.65
		18900	1880	12	13	1	23.6	21.91
		19175	1907.5	12	13	1	23.6	21.94
	18625	1852.5	25	0	1	23.6	21.93	
	18900	1880	25	0	1	23.6	22.19	
	19175	1907.5	25	0	1	23.6	22.22	
	18625	1852.5	1	0	1	23.6	21.97	
	18900	1880	1	0	1	23.6	22.19	
	19175	1907.5	1	0	1	23.6	22.25	
	18625	1852.5	1	12	1	23.6	21.65	
	18900	1880	1	12	1	23.6	21.91	
	19175	1907.5	1	12	1	23.6	21.94	
	18625	1852.5	1	24	1	23.6	22.41	
	18900	1880	1	24	1	23.6	22.67	
	19175	1907.5	1	24	1	23.6	22.7	
18625	1852.5	12	0	2	23.6	20.65		
18900	1880	12	0	2	23.6	20.91		
19175	1907.5	12	0	2	23.6	20.94		
18625	1852.5	12	6	2	23.6	20.61		
18900	1880	12	6	2	23.6	20.87		
19175	1907.5	12	6	2	23.6	20.9		
18625	1852.5	12	13	2	23.6	20.61		
18900	1880	12	13	2	23.6	20.87		
19175	1907.5	12	13	2	23.6	20.9		
18625	1852.5	25	0	2	23.6	20.73		
18900	1880	25	0	2	23.6	20.99		
19175	1907.5	25	0	2	23.6	21.02		



A D T

LTE Band 2								
BW	Modulation	CH	Frequency	RB	RB Offset	MPR	Target	Measured
			(MHz)				Power	Power
10MHz	QPSK	18650	1855	1	0	0	23.6	22.99
		18900	1880	1	0	0	23.6	23.25
		19150	1905	1	0	0	23.6	23.28
		18650	1855	1	24	0	23.6	22.72
		18900	1880	1	24	0	23.6	22.98
		19150	1905	1	24	0	23.6	23.01
		18650	1855	1	49	0	23.6	23.2
		18900	1880	1	49	0	23.6	23.46
		19150	1905	1	49	0	23.6	23.49
		18650	1855	25	0	1	23.6	21.64
		18900	1880	25	0	1	23.6	21.9
		19150	1905	25	0	1	23.6	21.93
		18650	1855	25	12	1	23.6	21.63
		18900	1880	25	12	1	23.6	21.89
		19150	1905	25	12	1	23.6	21.92
		18650	1855	25	25	1	23.6	21.67
		18900	1880	25	25	1	23.6	21.93
		19150	1905	25	25	1	23.6	21.96
	18650	1855	50	0	1	23.6	21.95	
	18900	1880	50	0	1	23.6	22.21	
	19150	1905	50	0	1	23.6	22.24	
	18650	1855	1	0	1	23.6	21.99	
	18900	1880	1	0	1	23.6	22.21	
	19150	1905	1	0	1	23.6	22.27	
	18650	1855	1	24	1	23.6	21.67	
	18900	1880	1	24	1	23.6	21.93	
	19150	1905	1	24	1	23.6	21.96	
	18650	1855	1	49	1	23.6	22.43	
	18900	1880	1	49	1	23.6	22.69	
	19150	1905	1	49	1	23.6	22.72	
	18650	1855	25	0	2	23.6	20.67	
	18900	1880	25	0	2	23.6	20.93	
	19150	1905	25	0	2	23.6	20.96	
	18650	1855	25	12	2	23.6	20.63	
	18900	1880	25	12	2	23.6	20.89	
	19150	1905	25	12	2	23.6	20.92	
18650	1855	25	25	2	23.6	20.63		
18900	1880	25	25	2	23.6	20.89		
19150	1905	25	25	2	23.6	20.92		
18650	1855	50	0	2	23.6	20.75		
18900	1880	50	0	2	23.6	21.01		
19150	1905	50	0	2	23.6	21.04		



A D T

LTE Band 2								
BW	Modulation	CH	Frequency	RB	RB Offset	MPR	Target	Measured
			(MHz)				Power	Power
15 MHz	QPSK	18675	1857.5	1	0	0	23.6	23.05
		18900	1880	1	0	0	23.6	23.31
		19125	1902.5	1	0	0	23.6	23.34
		18675	1857.5	1	37	0	23.6	22.78
		18900	1880	1	37	0	23.6	23.04
		19125	1902.5	1	37	0	23.6	23.07
		18675	1857.5	1	74	0	23.6	23.26
		18900	1880	1	74	0	23.6	23.52
		19125	1902.5	1	74	0	23.6	23.55
		18675	1857.5	36	0	1	23.6	21.7
		18900	1880	36	0	1	23.6	21.96
		19125	1902.5	36	0	1	23.6	21.99
		18675	1857.5	36	19	1	23.6	21.69
		18900	1880	36	19	1	23.6	21.95
		19125	1902.5	36	19	1	23.6	21.98
	18675	1857.5	36	39	1	23.6	21.63	
	18900	1880	36	39	1	23.6	21.89	
	19125	1902.5	36	39	1	23.6	21.92	
	18675	1857.5	75	0	1	23.6	22.01	
	18900	1880	75	0	1	23.6	22.27	
	19125	1902.5	75	0	1	23.6	22.3	
	18675	1857.5	1	0	1	23.6	22.05	
	18900	1880	1	0	1	23.6	22.27	
	19125	1902.5	1	0	1	23.6	22.33	
	18675	1857.5	1	37	1	23.6	21.63	
	18900	1880	1	37	1	23.6	21.89	
	19125	1902.5	1	37	1	23.6	21.92	
	18675	1857.5	1	74	1	23.6	22.49	
	18900	1880	1	74	1	23.6	22.75	
	19125	1902.5	1	74	1	23.6	22.78	
18675	1857.5	36	0	2	23.6	20.63		
18900	1880	36	0	2	23.6	20.89		
19125	1902.5	36	0	2	23.6	20.92		
18675	1857.5	36	19	2	23.6	20.69		
18900	1880	36	19	2	23.6	20.95		
19125	1902.5	36	19	2	23.6	20.98		
18675	1857.5	36	39	2	23.6	20.69		
18900	1880	36	39	2	23.6	20.95		
19125	1902.5	36	39	2	23.6	20.98		
18675	1857.5	75	0	2	23.6	20.81		
18900	1880	75	0	2	23.6	21.07		
19125	1902.5	75	0	2	23.6	21.1		



A D T

LTE Band 2								
BW	Modulation	CH	Frequency	RB	RB Offset	MPR	Target	Measured
			(MHz)				Power	Power
20MHz	QPSK	18700	1860	1	0	0	23.6	23.08
		18900	1880	1	0	0	23.6	23.34
		19100	1900	1	0	0	23.6	23.37
		18700	1860	1	50	0	23.6	22.81
		18900	1880	1	50	0	23.6	23.07
		19100	1900	1	50	0	23.6	23.1
		18700	1860	1	99	0	23.6	23.29
		18900	1880	1	99	0	23.6	23.55
		19100	1900	1	99	0	23.6	23.58
		18700	1860	50	0	1	23.6	21.73
		18900	1880	50	0	1	23.6	21.99
		19100	1900	50	0	1	23.6	22.02
		18700	1860	50	25	1	23.6	21.72
		18900	1880	50	25	1	23.6	21.98
		19100	1900	50	25	1	23.6	22.01
	18700	1860	50	50	1	23.6	21.66	
	18900	1880	50	50	1	23.6	21.92	
	19100	1900	50	50	1	23.6	21.95	
	18700	1860	100	0	1	23.6	22.04	
	18900	1880	100	0	1	23.6	22.3	
	19100	1900	100	0	1	23.6	22.33	
	18700	1860	1	0	1	23.6	22.08	
	18900	1880	1	0	1	23.6	22.3	
	19100	1900	1	0	1	23.6	22.36	
	18700	1860	1	50	1	23.6	21.66	
	18900	1880	1	50	1	23.6	21.92	
	19100	1900	1	50	1	23.6	21.95	
	18700	1860	1	99	1	23.6	22.52	
	18900	1880	1	99	1	23.6	22.78	
	19100	1900	1	99	1	23.6	22.81	
18700	1860	50	0	2	23.6	20.66		
18900	1880	50	0	2	23.6	20.92		
19100	1900	50	0	2	23.6	20.95		
18700	1860	50	25	2	23.6	20.62		
18900	1880	50	25	2	23.6	20.88		
19100	1900	50	25	2	23.6	20.91		
18700	1860	50	50	2	23.6	20.62		
18900	1880	50	50	2	23.6	20.88		
19100	1900	50	50	2	23.6	20.91		
18700	1860	100	0	2	23.6	20.84		
18900	1880	100	0	2	23.6	21.1		
19100	1900	100	0	2	23.6	21.13		
	16QAM	18700	1860	1	0	1	23.6	22.08
		18900	1880	1	0	1	23.6	22.3
		19100	1900	1	0	1	23.6	22.36
		18700	1860	1	50	1	23.6	21.66
		18900	1880	1	50	1	23.6	21.92
		19100	1900	1	50	1	23.6	21.95
		18700	1860	1	99	1	23.6	22.52
		18900	1880	1	99	1	23.6	22.78
		19100	1900	1	99	1	23.6	22.81



A D T

EIRP POWER (dBm)

GSM

Plane	Channel	Frequency (MHz)	LVL (dBm)	Correction Factor(dB)	EIRP(dBm)	EIRP(mW)	Polarization (H/V)
Y	512	1850.2	-10.57	38.19	27.62	578.10	H
	661	1880.0	-10.96	38.70	27.74	594.29	H
	810	1909.8	-11.14	38.43	27.29	535.80	H
	512	1850.2	-7.91	38.48	30.57	1140.25	V
	661	1880.0	-7.61	38.59	30.98	1253.14	V
	810	1909.8	-8.41	38.87	30.46	1111.73	V

EDGE

Plane	Channel	Frequency (MHz)	LVL (dBm)	Correction Factor(dB)	EIRP(dBm)	EIRP(mW)	Polarization (H/V)
Y	512	1850.2	-14.71	38.19	23.48	222.84	H
	661	1880.0	-15.34	38.70	23.36	216.77	H
	810	1909.8	-14.64	38.43	23.79	239.33	H
	512	1850.2	-11.92	38.48	26.56	452.90	V
	661	1880.0	-12.27	38.59	26.32	428.55	V
	810	1909.8	-12.67	38.87	26.20	416.87	V

WCDMA

Plane	Channel	Frequency (MHz)	LVL (dBm)	Correction Factor(dB)	EIRP(dBm)	EIRP(mW)	Polarization (H/V)
Y	9262	1852.4	-17.79	38.19	20.40	109.65	H
	9400	1880.0	-18.41	38.70	20.29	106.91	H
	9538	1907.6	-17.84	38.43	20.59	114.55	H
	9262	1852.4	-15.03	38.48	23.45	221.31	V
	9400	1880.0	-15.55	38.59	23.04	201.37	V
	9538	1907.6	-15.43	38.87	23.44	220.80	V

**LTE BAND 2****CHANNEL BANDWIDTH: 1.4MHz QPSK**

Plane	Channel	Frequency (MHz)	LVL (dBm)	Correction Factor(dB)	EIRP(dBm)	EIRP(mW)	Polarization (H/V)
X	18607	1850.7	-14.73	38.19	23.46	221.82	H
	18900	1880	-14.80	38.70	23.90	245.47	H
	19193	1909.3	-15.61	39.35	23.74	236.59	H
	18607	1850.7	-18.84	38.48	19.64	92.04	V
	18900	1880	-19.12	38.59	19.47	88.51	V
	19193	1909.3	-19.16	38.87	19.71	93.54	V

CHANNEL BANDWIDTH: 1.4MHz 16QAM

Plane	Channel	Frequency (MHz)	LVL (dBm)	Correction Factor(dB)	EIRP(dBm)	EIRP(mW)	Polarization (H/V)
X	18607	1850.7	-15.53	38.19	22.66	184.50	H
	18900	1880	-16.26	38.70	22.44	175.39	H
	19193	1909.3	-16.27	39.35	23.08	203.24	H
	18607	1850.7	-18.73	38.48	19.75	94.41	V
	18900	1880	-19.31	38.59	19.28	84.72	V
	19193	1909.3	-19.71	38.87	19.16	82.41	V



CHANNEL BANDWIDTH: 3MHz QPSK

Plane	Channel	Frequency (MHz)	LVL (dBm)	Correction Factor(dB)	EIRP(dBm)	EIRP(mW)	Polarization (H/V)
X	18615	1851.5	-14.57	38.19	23.62	230.14	H
	18900	1880	-15.06	38.70	23.64	231.21	H
	19185	1908.5	-15.44	39.35	23.91	246.04	H
	18615	1851.5	-18.64	38.48	19.84	96.38	V
	18900	1880	-19.16	38.59	19.43	87.70	V
	19185	1908.5	-19.07	38.87	19.80	95.50	V

CHANNEL BANDWIDTH: 3MHz 16QAM

Plane	Channel	Frequency (MHz)	LVL (dBm)	Correction Factor(dB)	EIRP(dBm)	EIRP(mW)	Polarization (H/V)
X	18615	1851.5	-14.28	38.19	23.91	246.04	H
	18900	1880	-14.80	38.70	23.90	245.47	H
	19185	1908.5	-16.23	39.35	23.12	205.12	H
	18615	1851.5	-19.29	38.48	19.19	82.99	V
	18900	1880	-19.11	38.59	19.48	88.72	V
	19185	1908.5	-19.85	38.87	19.02	79.80	V



CHANNEL BANDWIDTH: 5MHz QPSK

Plane	Channel	Frequency (MHz)	LVL (dBm)	Correction Factor(dB)	EIRP(dBm)	EIRP(mW)	Polarization (H/V)
X	18625	1852.5	-15.18	38.19	23.01	199.99	H
	18900	1880	-15.27	38.70	23.43	220.29	H
	19175	1907.5	-15.94	39.35	23.41	219.28	H
	18625	1852.5	-19.39	38.48	19.09	81.10	V
	18900	1880	-19.12	38.59	19.47	88.51	V
	19175	1907.5	-19.79	38.87	19.08	80.91	V

CHANNEL BANDWIDTH: 5MHz 16QAM

Plane	Channel	Frequency (MHz)	LVL (dBm)	Correction Factor(dB)	EIRP(dBm)	EIRP(mW)	Polarization (H/V)
X	18625	1852.5	-14.91	38.19	23.28	212.81	H
	18900	1880	-15.29	38.70	23.41	219.28	H
	19175	1907.5	-15.87	39.35	23.48	222.84	H
	18625	1852.5	-19.17	38.48	19.31	85.31	V
	18900	1880	-19.08	38.59	19.51	89.33	V
	19175	1907.5	-19.76	38.87	19.11	81.47	V



CHANNEL BANDWIDTH: 10MHz QPSK

Plane	Channel	Frequency (MHz)	LVL (dBm)	Correction Factor(dB)	EIRP(dBm)	EIRP(mW)	Polarization (H/V)
X	18650	1855	-14.85	38.19	23.34	215.77	H
	18900	1880	-15.60	38.70	23.10	204.17	H
	19150	1905	-15.41	39.35	23.94	247.74	H
	18650	1855	-19.61	38.48	18.87	77.09	V
	18900	1880	-19.30	38.59	19.29	84.92	V
	19150	1905	-19.90	38.87	18.97	78.89	V

CHANNEL BANDWIDTH: 10MHz 16QAM

Plane	Channel	Frequency (MHz)	LVL (dBm)	Correction Factor(dB)	EIRP(dBm)	EIRP(mW)	Polarization (H/V)
X	18650	1855	-14.55	38.19	23.64	231.21	H
	18900	1880	-15.37	38.70	23.33	215.28	H
	19150	1905	-16.27	39.35	23.08	203.24	H
	18650	1855	-19.31	38.48	19.17	82.60	V
	18900	1880	-19.41	38.59	19.18	82.79	V
	19150	1905	-19.69	38.87	19.18	82.79	V

**CHANNEL BANDWIDTH: 15MHz QPSK**

Plane	Channel	Frequency (MHz)	LVL (dBm)	Correction Factor(dB)	EIRP(dBm)	EIRP(mW)	Polarization (H/V)
X	18675	1857.5	-14.41	38.19	23.78	238.78	H
	18900	1880	-15.53	38.70	23.17	207.49	H
	19125	1902.5	-16.25	39.35	23.10	204.17	H
	18675	1857.5	-18.56	38.48	19.92	98.17	V
	18900	1880	-19.00	38.59	19.59	90.99	V
	19125	1902.5	-19.76	38.87	19.11	81.47	V

CHANNEL BANDWIDTH: 15MHz 16QAM

Plane	Channel	Frequency (MHz)	LVL (dBm)	Correction Factor(dB)	EIRP(dBm)	EIRP(mW)	Polarization (H/V)
X	18675	1857.5	-15.16	38.19	23.03	200.91	H
	18900	1880	-15.34	38.70	23.36	216.77	H
	19125	1902.5	-16.16	39.35	23.19	208.45	H
	18675	1857.5	-19.34	38.48	19.14	82.04	V
	18900	1880	-18.88	38.59	19.71	93.54	V
	19125	1902.5	-19.70	38.87	19.17	82.60	V

**CHANNEL BANDWIDTH: 20MHz QPSK**

Plane	Channel	Frequency (MHz)	LVL (dBm)	Correction Factor(dB)	EIRP(dBm)	EIRP(mW)	Polarization (H/V)
X	18700	1860	-14.17	38.19	24.02	252.35	H
	18900	1880	-14.77	38.70	23.93	247.17	H
	19100	1900	-15.47	39.35	23.88	244.34	H
	18700	1860	-19.12	38.48	19.36	86.30	V
	18900	1880	-19.49	38.59	19.10	81.28	V
	19100	1900	-19.67	38.87	19.20	83.18	V

CHANNEL BANDWIDTH: 20MHz 16QAM

Plane	Channel	Frequency (MHz)	LVL (dBm)	Correction Factor(dB)	EIRP(dBm)	EIRP(mW)	Polarization (H/V)
X	18700	1860	-14.38	38.19	23.81	240.44	H
	18900	1880	-14.89	38.70	23.81	240.44	H
	19100	1900	-15.39	39.35	23.96	248.89	H
	18700	1860	-19.14	38.48	19.34	85.90	V
	18900	1880	-19.34	38.59	19.25	84.14	V
	19100	1900	-19.68	38.87	19.19	82.99	V

4.2 FREQUENCY STABILITY MEASUREMENT

4.2.1 LIMITS OF FREQUENCY STABILITY MEASUREMENT

The frequency stability shall be sufficient to ensure that the fundamental emission stays within the authorized frequency block.

4.2.2 TEST PROCEDURE

- a. Device is placed at the oven room. The oven room could control the temperatures and humidity. Power warm up is at least 15 min and power applied should perform before recording frequency error.
- b. EUT is connected the external power supply to control the DC input power. The test voltage range is from minimum to maximum working voltage. Each step shall be record the frequency error rate.
- c. The temperature range step is 10 degrees in this test items. All temperature levels shall be hold the $\pm 0.5^{\circ}\text{C}$ during the measurement testing. The each temperature step shall be at least 0.5 hours, consider the EUT could be test under the stability condition.

NOTE: The frequency error was recorded frequency error from the communication simulator.

4.2.3 TEST SETUP

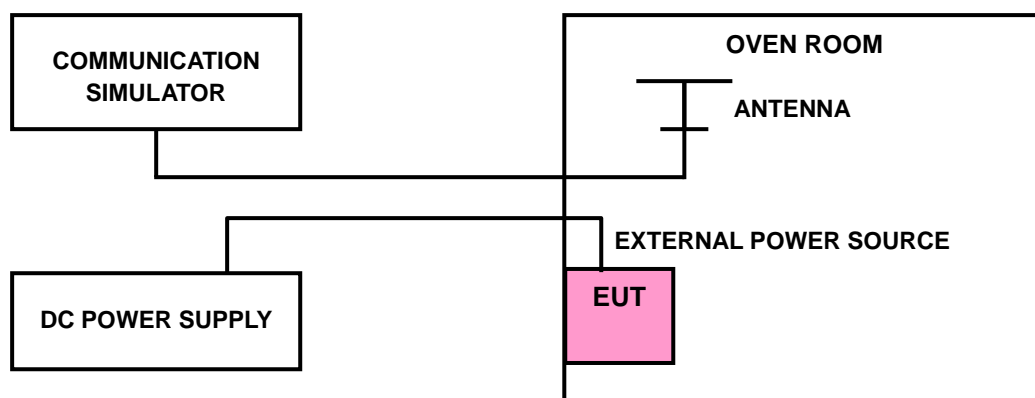



4.2.4 TEST RESULTS

FREQUENCY ERROR vs. VOLTAGE

VOLTAGE (Volts)	FREQUENCY ERROR (ppm)									LIMIT (ppm)
	GPRS	EDGE	WCDMA	LTE Band 2						
				1.4MHz	3MHz	5MHz	10MHz	15MHz	20MHz	
4.0	-0.03	-0.01	-0.005	0.01	0.005	-0.003	-0.02	-0.005	0.01	2.5
3.6	-0.03	-0.01	-0.005	-0.02	0.005	-0.002	-0.02	0.005	-0.02	2.5
4.30	-0.03	-0.01	-0.005	-0.01	-0.012	-0.016	-0.01	-0.015	-0.01	2.5

NOTE: The applicant defined the normal working voltage of the battery is from 3.6Vdc to 4.30Vdc.

FREQUENCY ERROR vs. TEMPERATURE.

TEMP. (°C)	FREQUENCY ERROR (ppm)									LIMIT (ppm)
	GPRS	EDGE	WCDMA	LTE Band 2						
				1.4MHz	3MHz	5MHz	10MHz	15MHz	20MHz	
-30	-0.02	-0.01	-0.005	-0.016	-0.018	-0.004	-0.036	0.017	-0.031	2.5
-20	-0.02	-0.01	-0.006	0.002	-0.020	-0.004	-0.005	-0.007	0.025	2.5
-10	-0.02	-0.01	-0.006	-0.004	-0.013	0.005	0.024	0.008	0.007	2.5
0	-0.02	-0.01	-0.006	0.003	0.005	-0.017	-0.019	-0.008	0.019	2.5
10	-0.02	-0.01	-0.005	0.001	-0.016	0.011	-0.014	-0.005	0.014	2.5
20	-0.02	-0.01	-0.005	-0.014	-0.010	0.016	-0.024	0.014	-0.038	2.5
30	-0.03	-0.01	-0.006	0.004	-0.013	0.004	0.005	-0.013	-0.004	2.5
40	-0.02	-0.01	-0.005	-0.004	-0.018	-0.005	-0.027	-0.005	0.005	2.5
50	-0.03	-0.01	-0.006	0.001	0.015	0.015	-0.024	0.002	-0.008	2.5
55	-0.03	-0.01	-0.004	-0.019	0.007	0.002	-0.010	-0.006	0.012	2.5

4.3 OCCUPIED BANDWIDTH MEASUREMENT

4.3.1 TEST PROCEDURES

The EUT makes a call to the communication simulator. All measurements were done at low, middle and high operational frequency range. The communication simulator station system controlled a EUT to export maximum output power under transmission mode and specific channel frequency. Use OBW measurement function of Spectrum analyzer to measure 99 % occupied bandwidth.

4.3.2 TEST SETUP

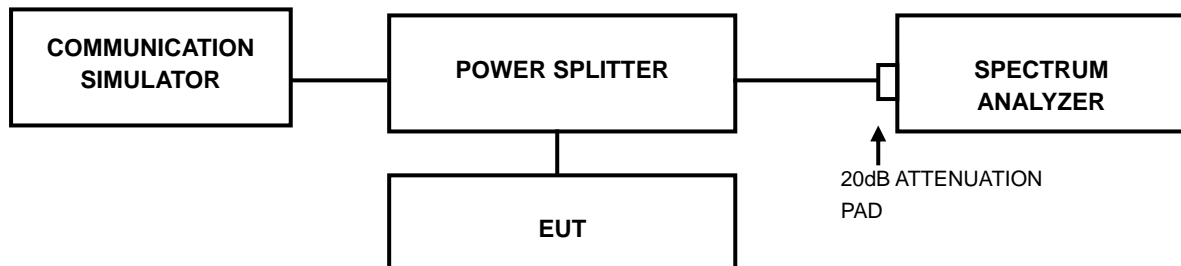



A D T

4.3.3 TEST RESULTS

CHANNEL	FREQUENCY (MHz)	99% OCCUPIED BANDWIDTH (kHz)		CHANNEL	FREQUENCY (MHz)	99% OCCUPIED BANDWIDTH (MHz)
		GPRS	EDGE			WCDMA
512	1850.2	245.49	245.16	9262	1852.4	4.1760
661	1880.0	239.29	250.10	9400	1880.0	4.1795
810	1909.8	241.66	244.19	9538	1907.6	4.1810

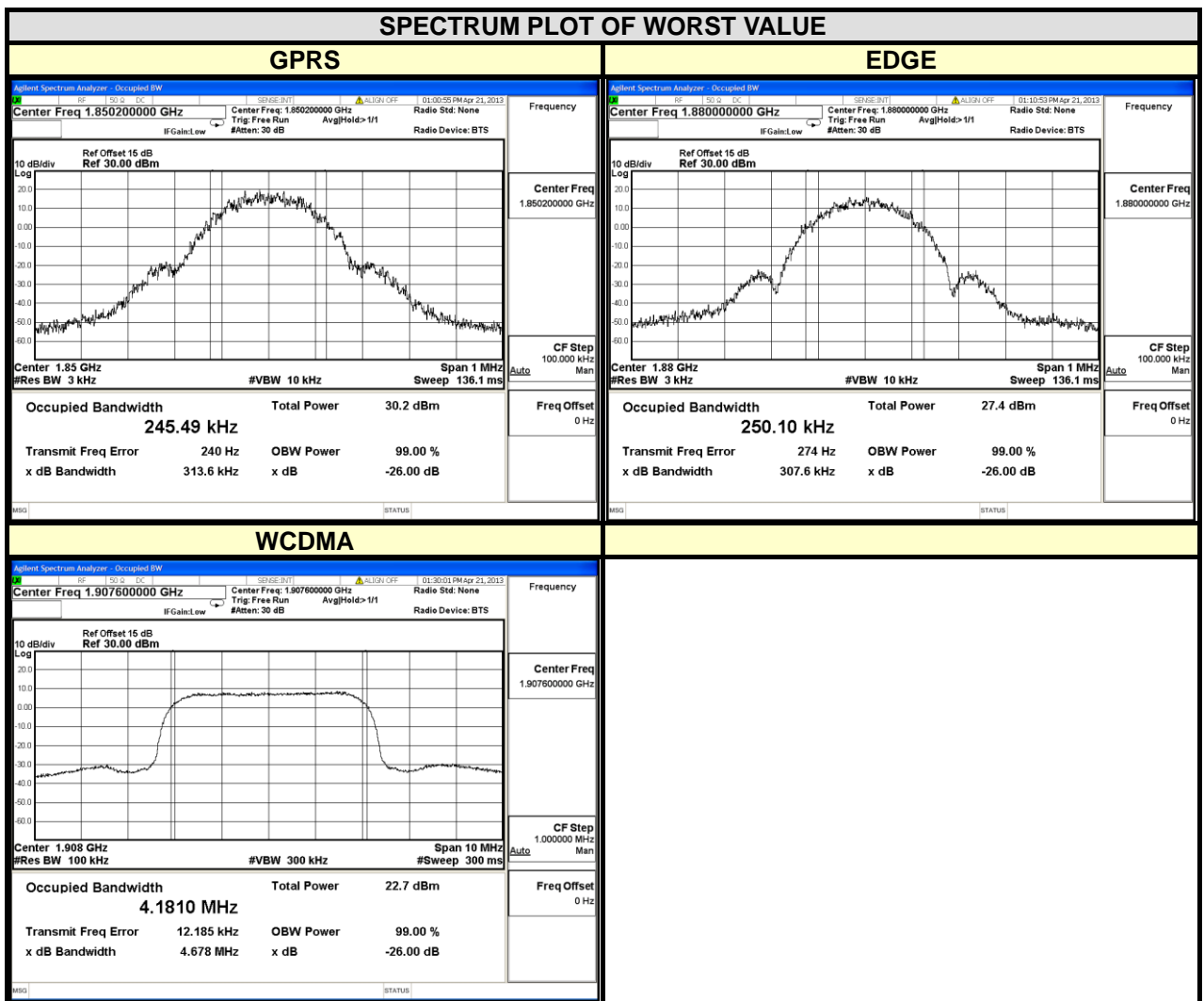



A D T

LTE BAND 2							
CHANNEL BANDWIDTH: 1.4MHz				CHANNEL BANDWIDTH: 3MHz			
CHANNEL	FREQUENCY (MHz)	99% OCCUPIED BANDWIDTH (MHz)		CHANNEL	FREQUENCY (MHz)	99% OCCUPIED BANDWIDTH (MHz)	
		QPSK	16QAM			QPSK	16QAM
18607	1850.7	1.0808	1.0791	18615	1851.5	2.6814	2.6807
18900	1880	1.0775	1.0770	18900	1880	2.6808	2.6813
19193	1909.3	1.0791	1.0909	19185	1908.5	2.6806	2.6819

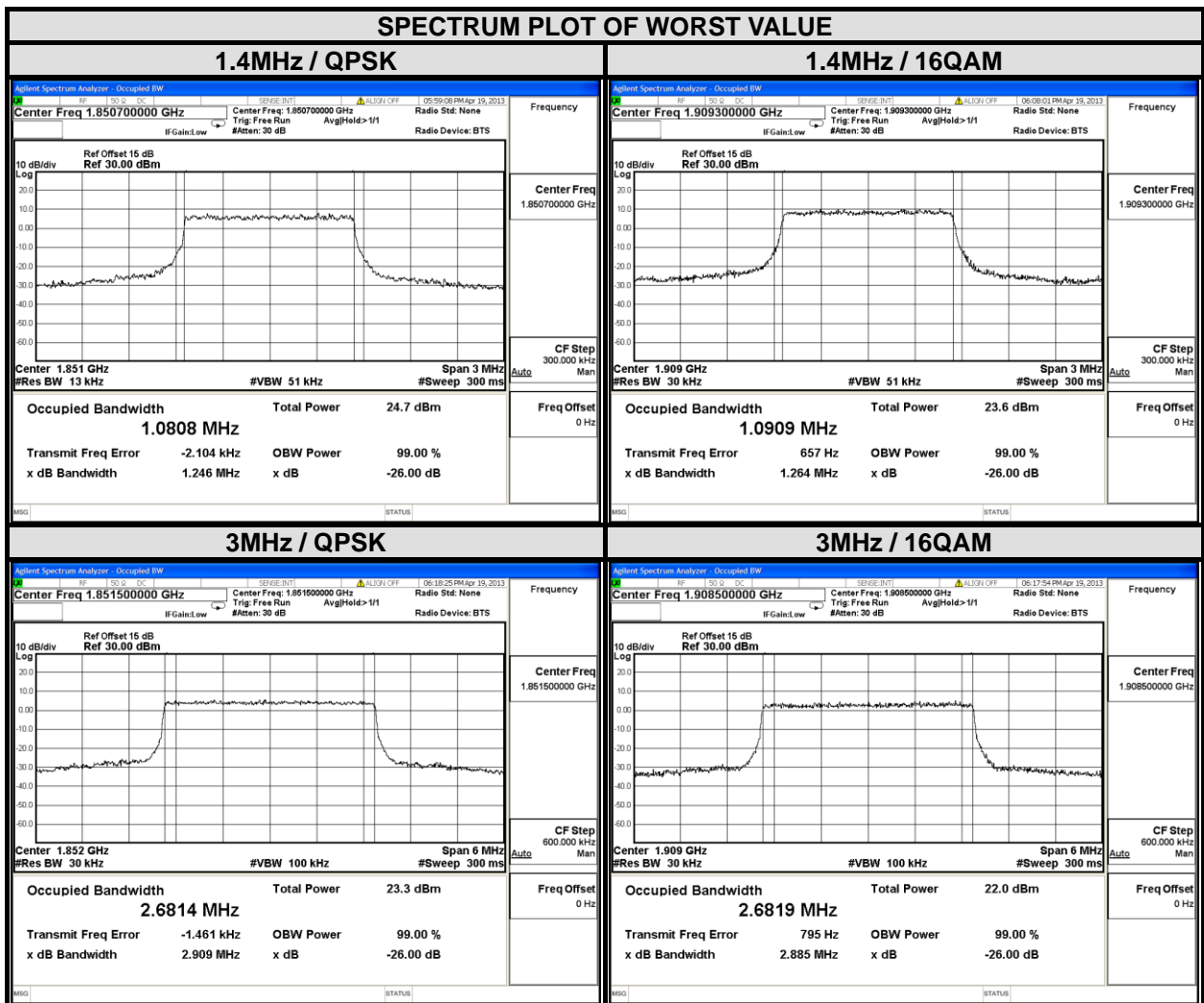



A D T

LTE BAND 2							
CHANNEL BANDWIDTH: 5MHz				CHANNEL BANDWIDTH: 10MHz			
CHANNEL	FREQUENCY (MHz)	99% OCCUPIED BANDWIDTH (MHz)		CHANNEL	FREQUENCY (MHz)	99% OCCUPIED BANDWIDTH (MHz)	
		QPSK	16QAM			QPSK	16QAM
18625	1852.5	4.4892	4.4893	18650	1855	8.9186	8.9185
18900	1880	4.4911	4.4904	18900	1880	8.9150	8.9180
19175	1907.5	4.4932	4.4875	19150	1905	8.9351	8.9363

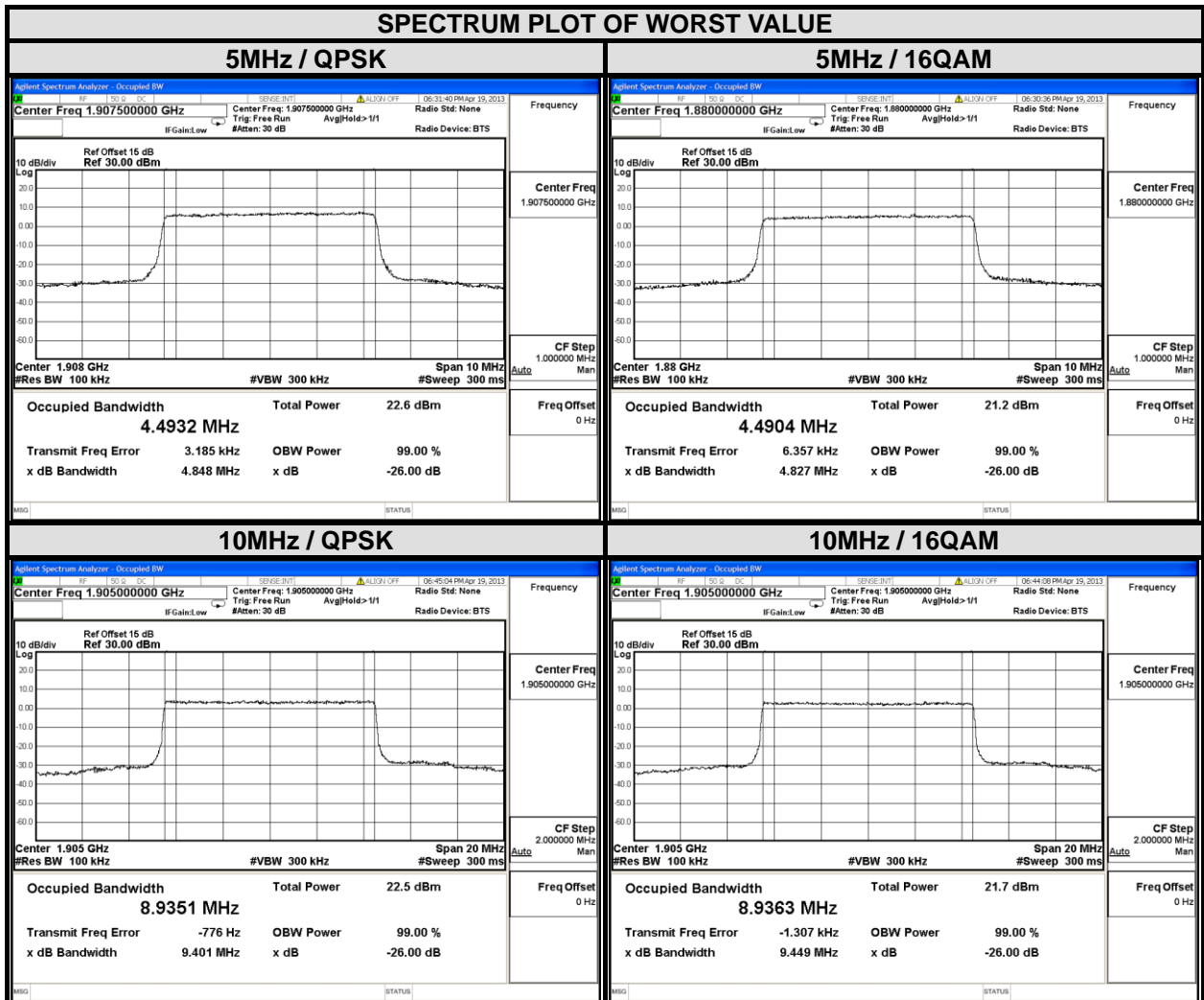



A D T

LTE BAND 2							
CHANNEL BANDWIDTH: 15MHz				CHANNEL BANDWIDTH: 20MHz			
CHANNEL	FREQUENCY (MHz)	99% OCCUPIED BANDWIDTH (MHz)		CHANNEL	FREQUENCY (MHz)	99% OCCUPIED BANDWIDTH (MHz)	
		QPSK	16QAM			QPSK	16QAM
18675	1857.5	13.383	13.377	18700	1860	17.827	17.846
18900	1880	13.373	13.375	18900	1880	17.826	17.822
19125	1902.5	13.424	13.419	19100	1900	17.843	17.836

SPECTRUM PLOT OF WORST VALUE

15MHz / QPSK

Center Freq: 1.902500000 GHz

Occupied Bandwidth: 13.424 MHz

Total Power: 22.2 dBm

Transmit Freq Error: -21.205 kHz

x dB Bandwidth: 13.99 MHz

15MHz / 16QAM

Center Freq: 1.902500000 GHz

Occupied Bandwidth: 13.419 MHz

Total Power: 21.0 dBm

Transmit Freq Error: -21.585 kHz

x dB Bandwidth: 14.08 MHz

20MHz / QPSK

Center Freq: 1.900000000 GHz

Occupied Bandwidth: 17.843 MHz

Total Power: 22.3 dBm

Transmit Freq Error: -57.463 kHz

x dB Bandwidth: 18.52 MHz

20MHz / 16QAM

Center Freq: 1.860000000 GHz

Occupied Bandwidth: 17.846 MHz

Total Power: 21.0 dBm

Transmit Freq Error: -6.461 kHz

x dB Bandwidth: 18.60 MHz

4.4 PEAK TO AVERAGE RATIO

4.4.1 LIMITS OF PEAK TO AVERAGE RATIO MEASUREMENT

In measuring transmissions in this band using an average power technique, the peak to-average ratio (PAR) of the transmission may not exceed 13 dB

4.4.2 TEST SETUP

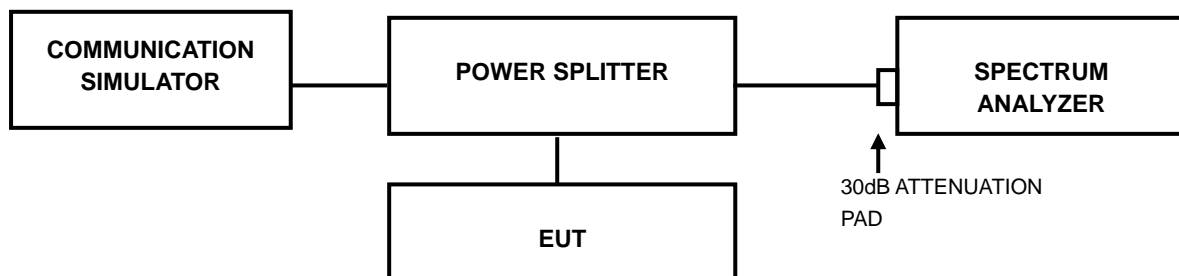

4.4.3 TEST PROCEDURES

1. Set resolution/measurement bandwidth \geq signal's occupied bandwidth;
2. Set the number of counts to a value that stabilizes the measured CCDF curve;
3. Record the maximum PAPR level associated with a probability of 0.1%.



A D T

4.4.4 TEST RESULTS

CHANNEL	FREQUENCY (MHz)	PEAK TO AVERAGE RATIO (dB)	
		GPRS	EDGE
512	1850.2	0.17	3.13
661	1880.0	0.18	3.19
810	1909.8	0.18	3.17

CHANNEL	FREQUENCY (MHz)	PEAK TO AVERAGE RATIO (dB)
		WCDMA
9262	1852.4	3.12
9400	1880.0	3.07
9538	1907.6	3.02

SPECTRUM PLOT OF WORST VALUE

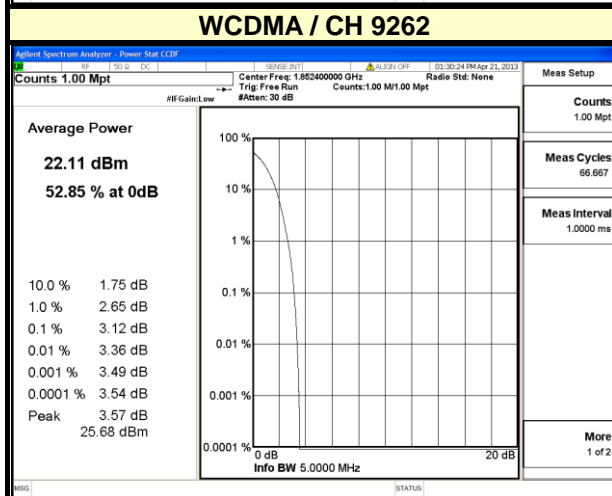
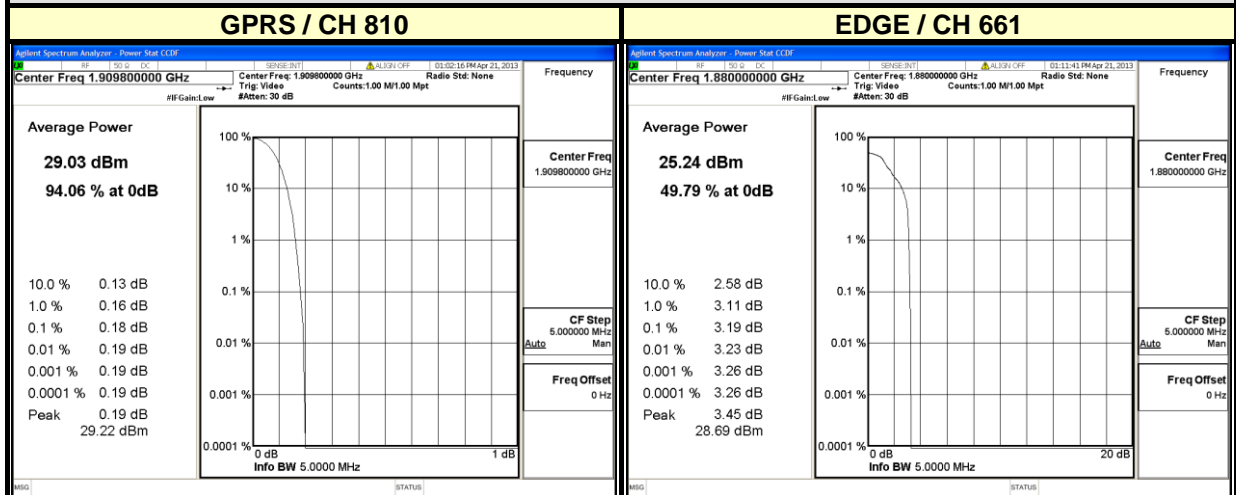



A D T

LTE BAND 2							
CHANNEL BANDWIDTH: 1.4MHz				CHANNEL BANDWIDTH: 3MHz			
CHANNEL	FREQUENCY (MHz)	PEAK TO AVERAGE RATIO (dB)		CHANNEL	FREQUENCY (MHz)	PEAK TO AVERAGE RATIO (dB)	
		QPSK	16QAM			QPSK	16QAM
18607	1850.7	3.34	4.40	18615	1851.5	3.26	4.35
18900	1880	3.82	5.07	18900	1880	3.99	5.22
19193	1909.3	3.66	4.94	19185	1908.5	4.07	5.23

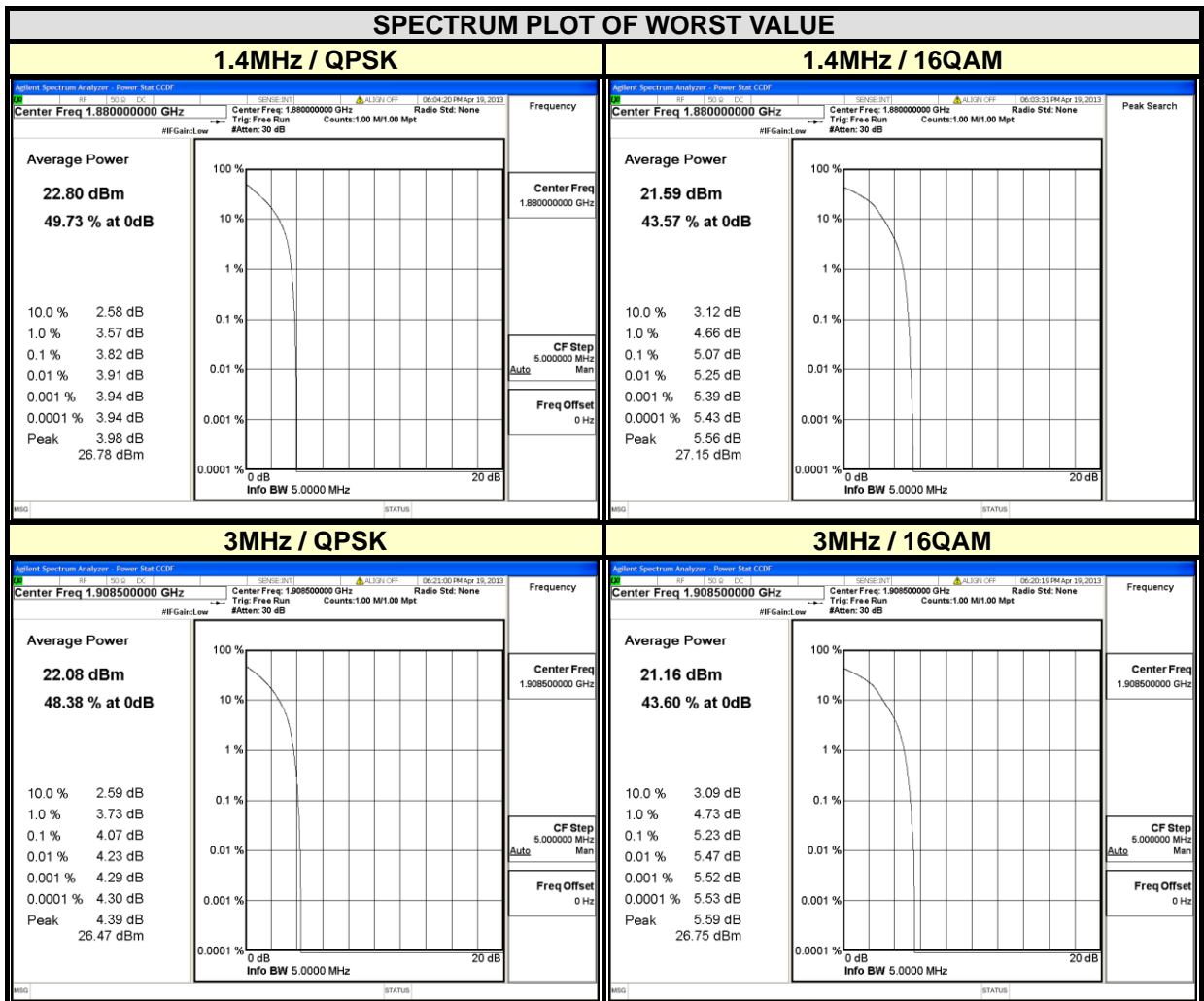



A D T

LTE BAND 2							
CHANNEL BANDWIDTH: 5MHz				CHANNEL BANDWIDTH: 10MHz			
CHANNEL	FREQUENCY (MHz)	PEAK TO AVERAGE RATIO (dB)		CHANNEL	FREQUENCY (MHz)	PEAK TO AVERAGE RATIO (dB)	
		QPSK	16QAM			QPSK	16QAM
18625	1852.5	3.26	4.42	18650	1855	3.25	4.42
18900	1880	4.14	5.24	18900	1880	4.27	5.39
19175	1907.5	4.35	5.51	19150	1905	4.49	5.68

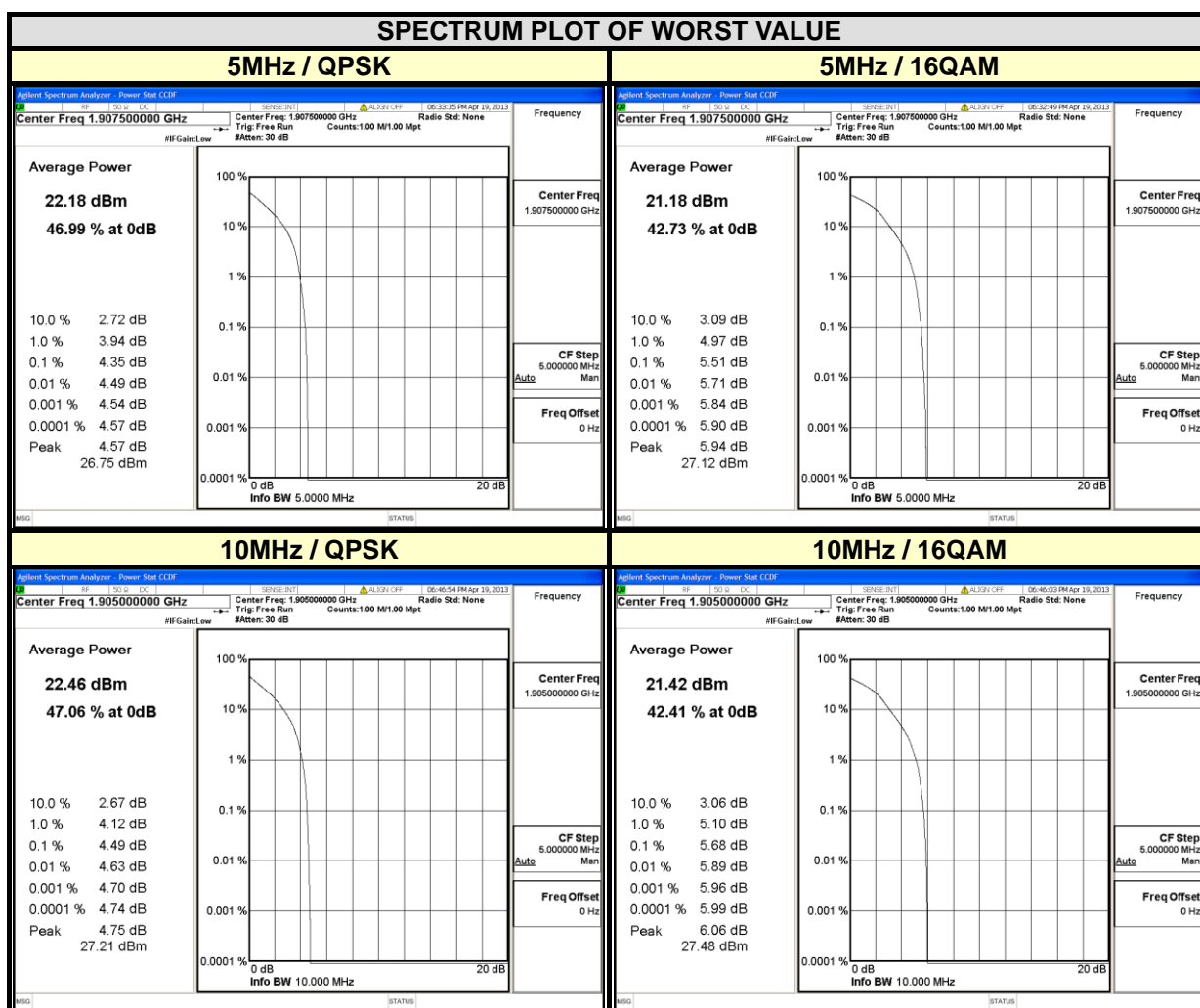



A D T

LTE BAND 2							
CHANNEL BANDWIDTH: 15MHz				CHANNEL BANDWIDTH: 20MHz			
CHANNEL	FREQUENCY (MHz)	PEAK TO AVERAGE RATIO (dB)		CHANNEL	FREQUENCY (MHz)	PEAK TO AVERAGE RATIO (dB)	
		QPSK	16QAM			QPSK	16QAM
18675	1857.5	3.34	4.38	18700	1860	3.42	4.39
18900	1880	4.73	5.76	18900	1880	4.74	5.84
19125	1902.5	4.08	5.39	19100	1900	3.56	4.81

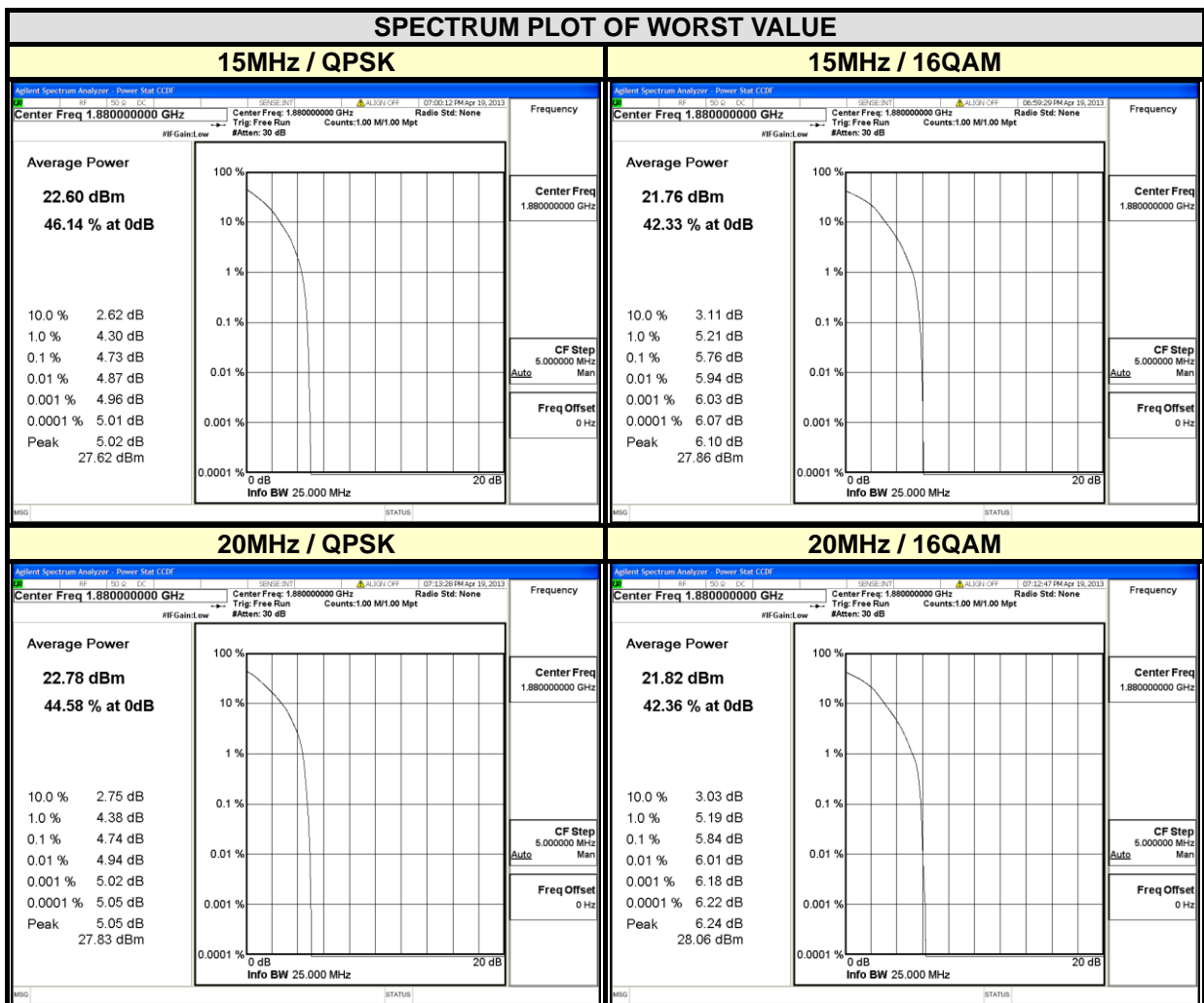

4.5 BAND EDGE MEASUREMENT

4.5.1 LIMITS OF BAND EDGE MEASUREMENT

Power of any emission outside of the authorized operating frequency ranges must be attenuated below the transmitting power (P) by a factor of at least $43 + 10 \log(P)$ dB. In the 1 MHz bands immediately outside and adjacent to the frequency block a resolution bandwidth of at least one percent of the emission bandwidth of the fundamental emission of the transmitter may be employed.

4.5.2 TEST SETUP

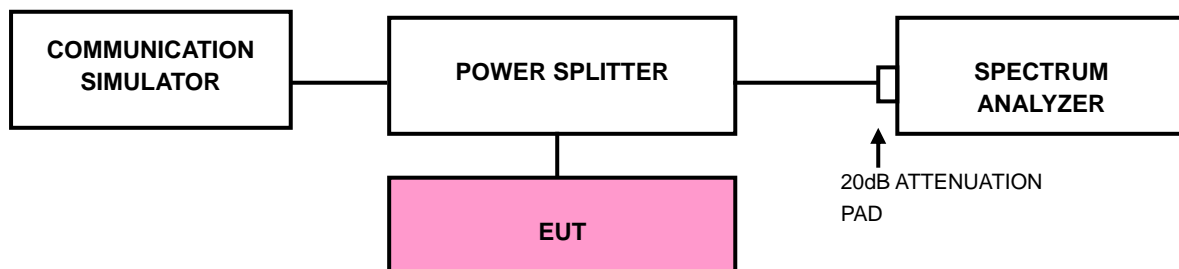

4.5.3 TEST PROCEDURES

- a. All measurements were done at low and high operational frequency range.
- b. The center frequency of spectrum is the band edge frequency and span is 1 MHz. RB of the spectrum is 3kHz and VB of the spectrum is 10kHz (GSM/GPRS/ EDGE).
- c. The center frequency of spectrum is the band edge frequency and span is 5MHz. RB of the spectrum is 100kHz and VB of the spectrum is 300kHz (WCDMA/LTE).
- d. Record the max trace plot into the test report.



A D T

4.5.4 TEST RESULTS

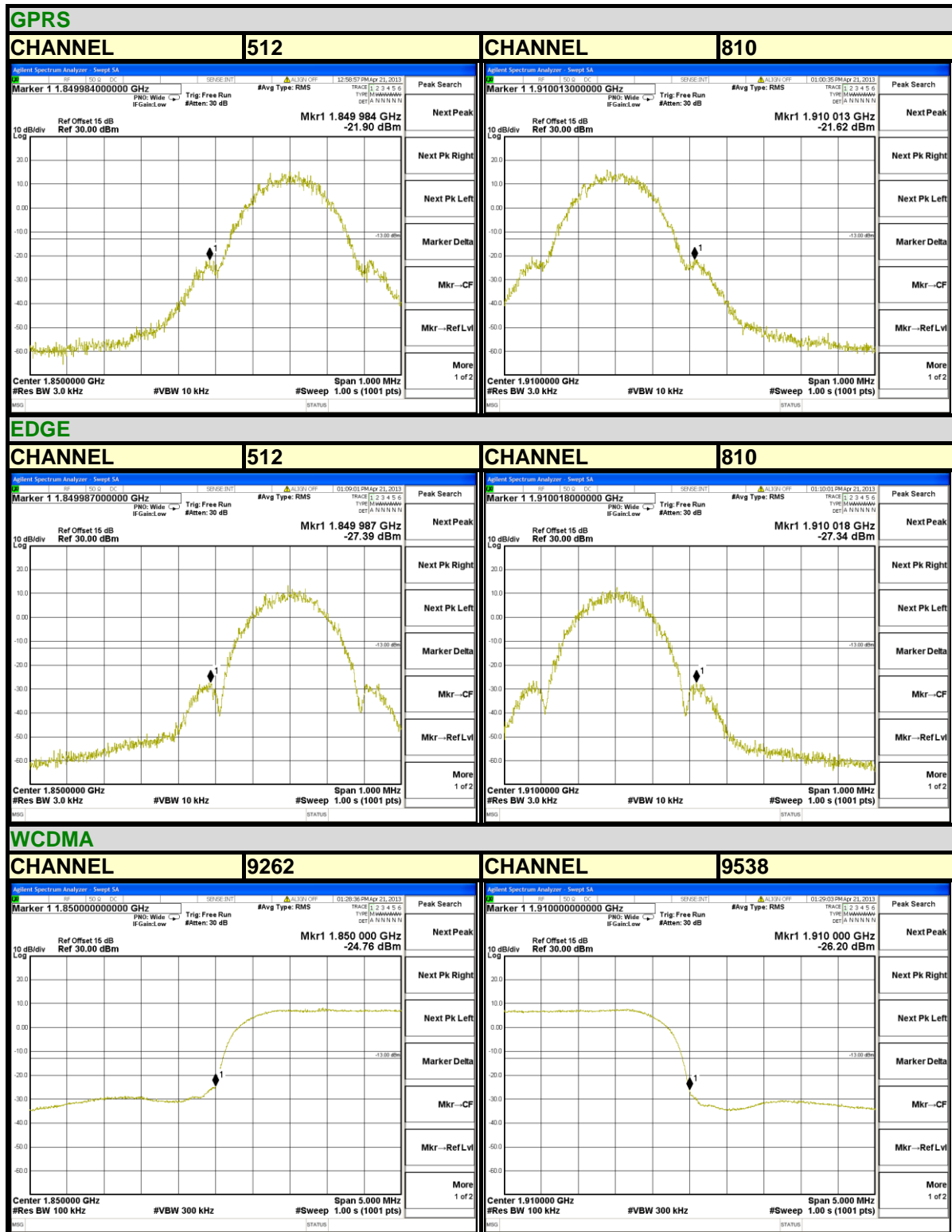



A D T

LTE Band 2 Channel Bandwidth: 1.4MHz

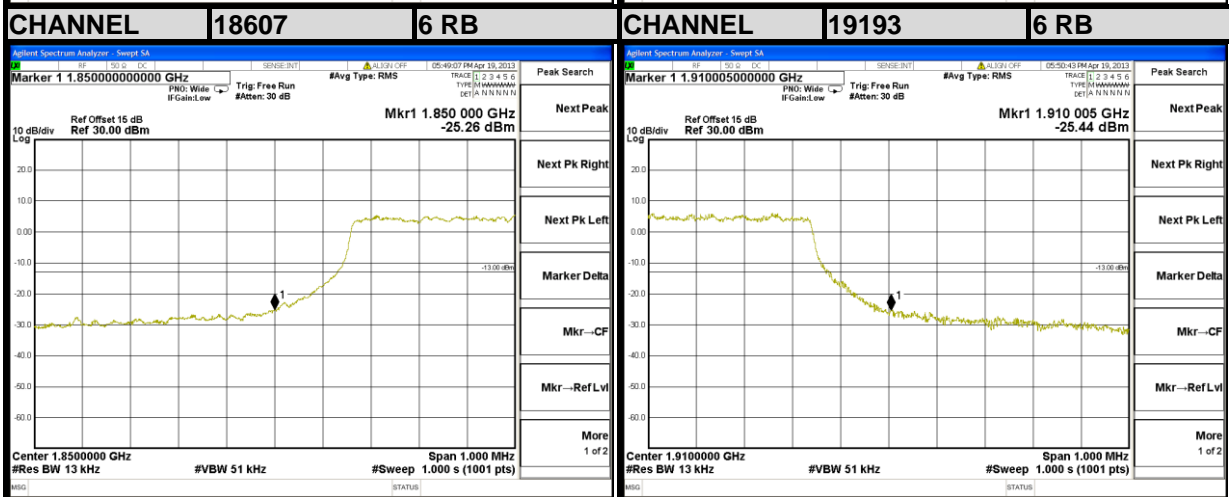
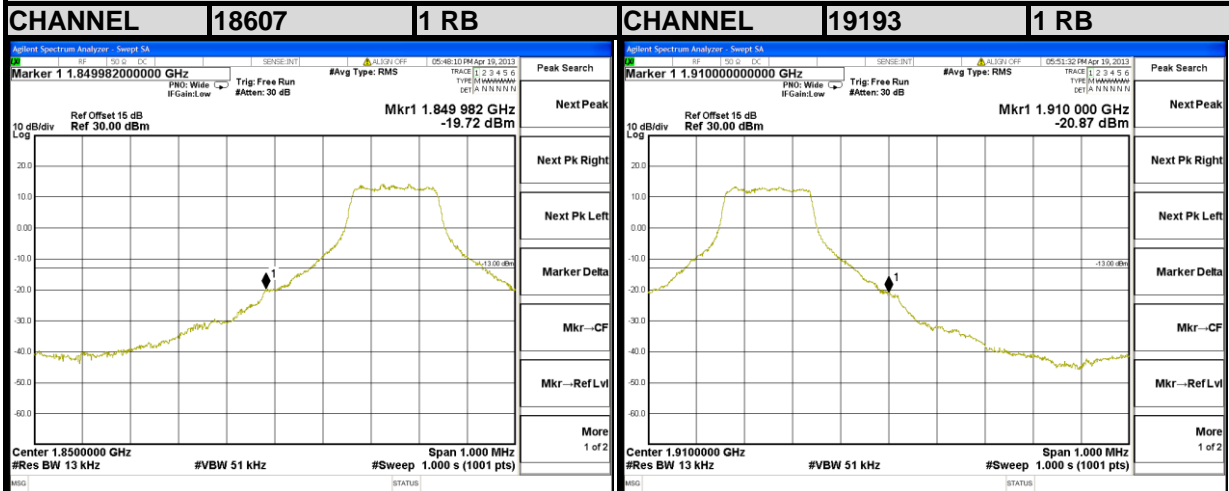



A D T

LTE Band 2

Channel Bandwidth: 3MHz

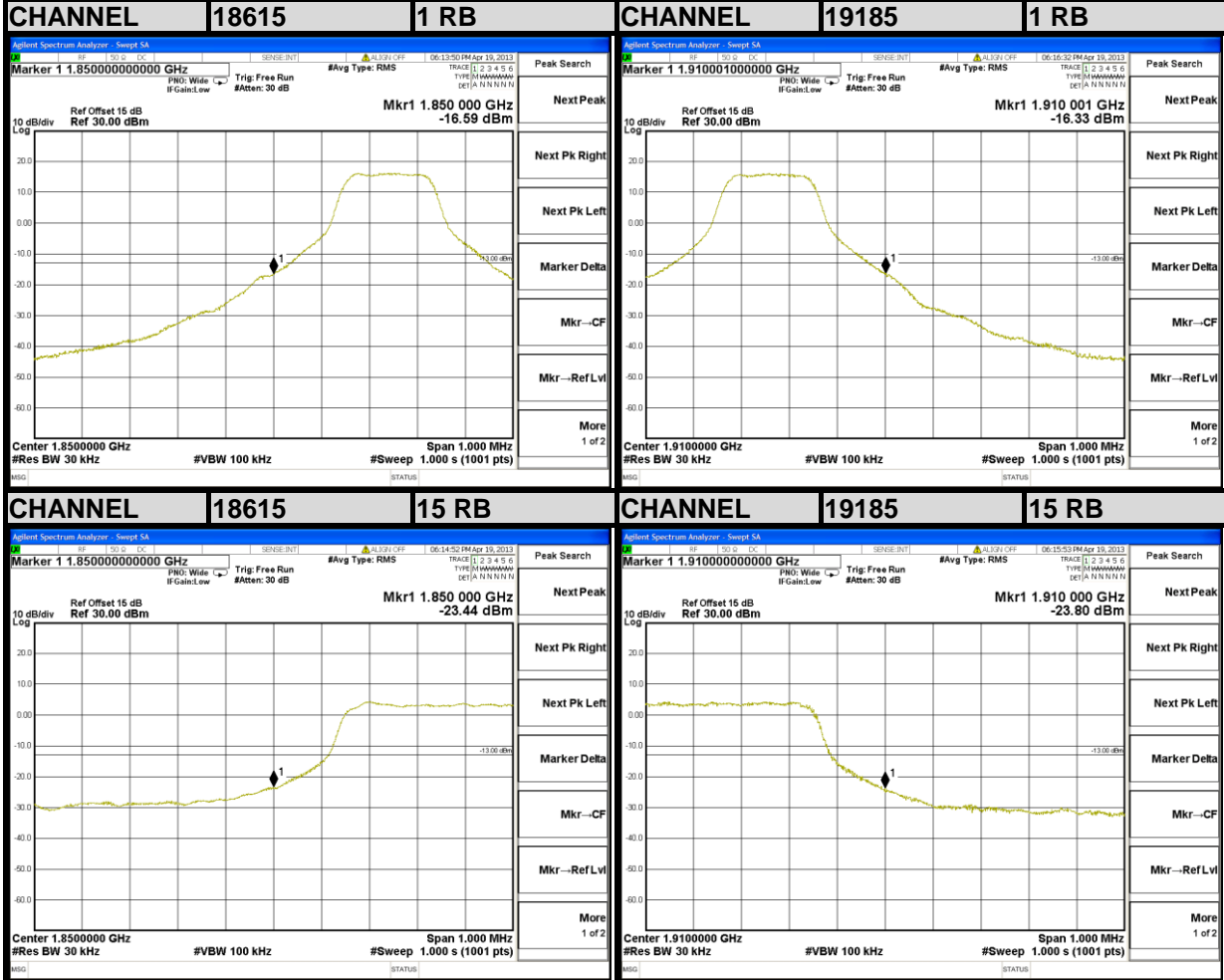



A D T

LTE Band 2

Channel Bandwidth: 5MHz

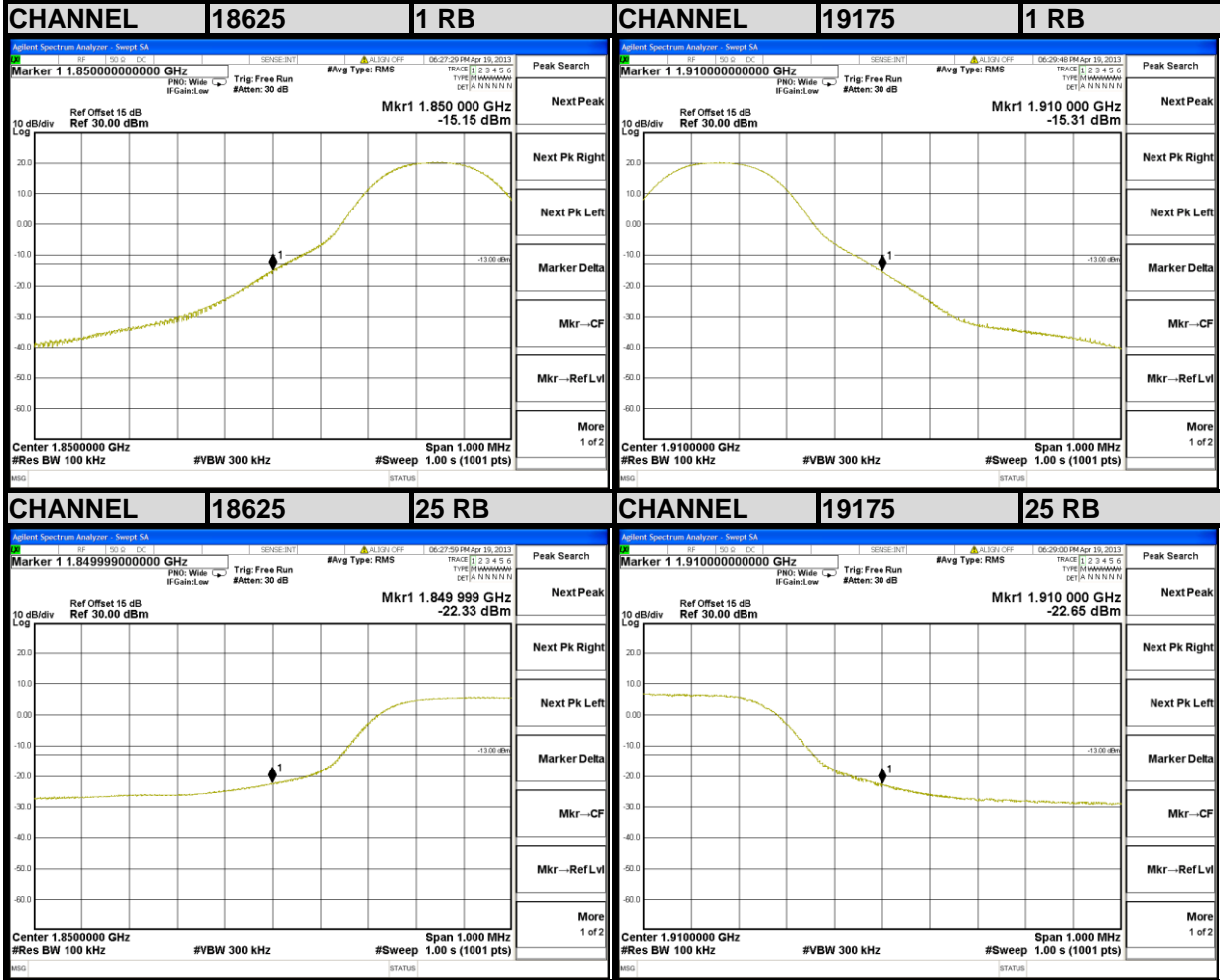



A D T

LTE Band 2

Channel Bandwidth: 10MHz

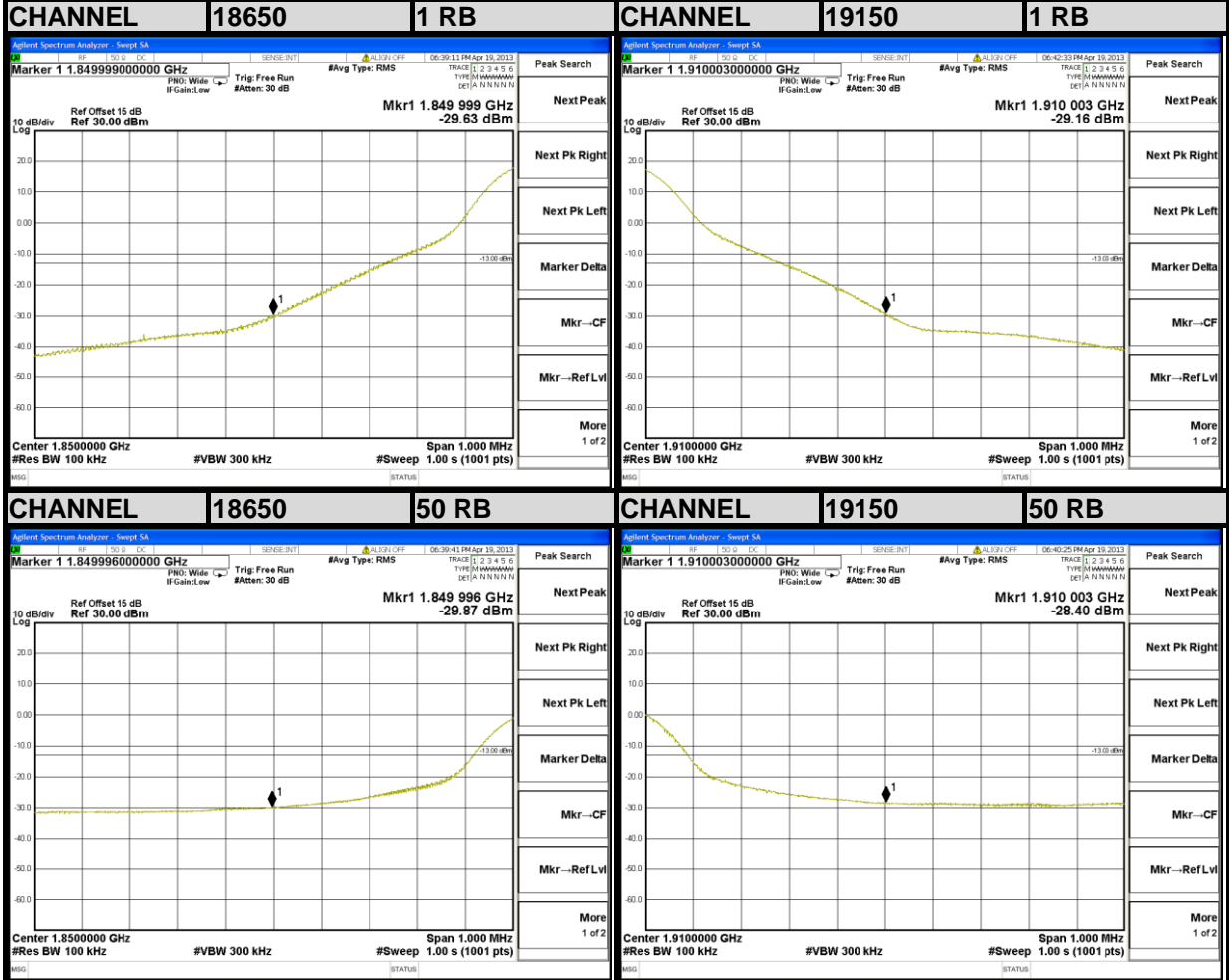



A D T

LTE Band 2 Channel Bandwidth: 15MHz

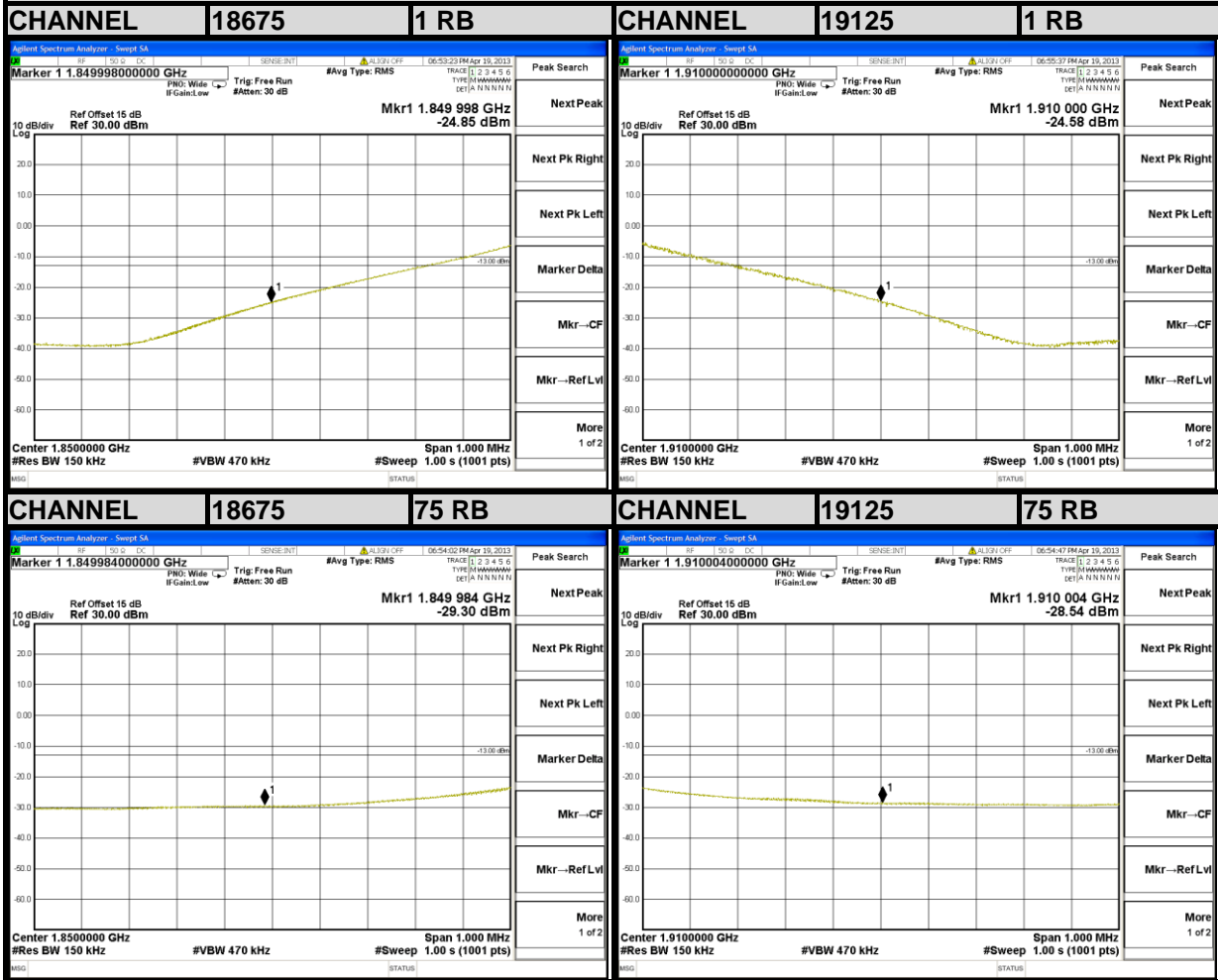



A D T

LTE Band 2

Channel Bandwidth: 20MHz

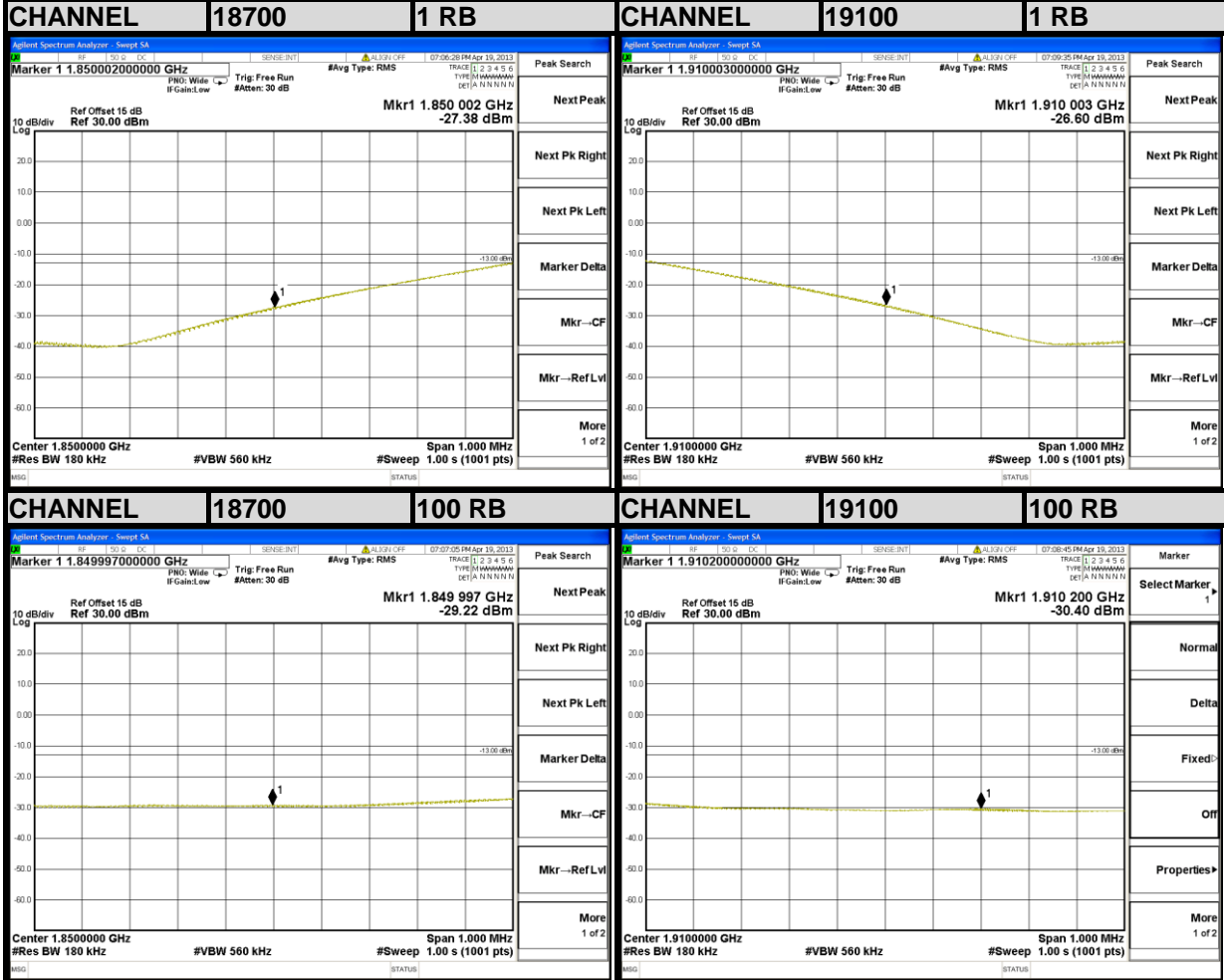

4.6 CONDUCTED SPURIOUS EMISSIONS

4.6.1 LIMITS OF CONDUCTED SPURIOUS EMISSIONS MEASUREMENT

The power of any emission outside of the authorized operating frequency ranges must be attenuated below the transmitting power (P) by a factor of at least $43 + 10 \log(P)$ dB. The emission limit equal to -13dBm .

4.6.2 TEST PROCEDURE

- a. The EUT makes a phone call to the communication simulator. All measurements were done at low, middle and high operational frequency range.
- b. Measuring frequency range is from 30 MHz to 19.1GHz. 10dB attenuation pad is connected with spectrum. RBW=1MHz and VBW=3MHz is used for conducted emission measurement.

4.6.3 TEST SETUP

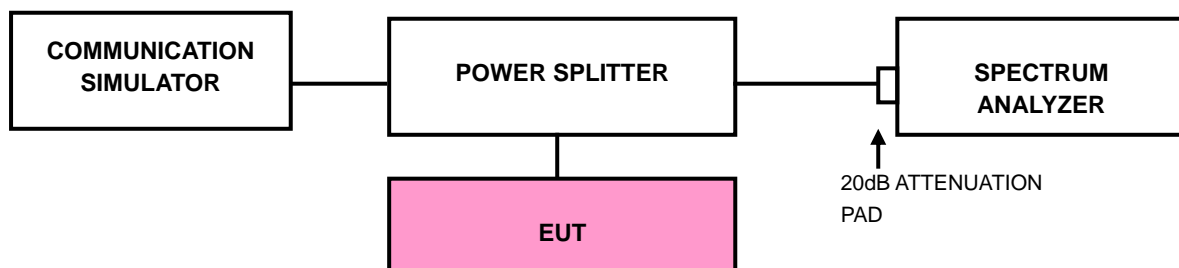



A D T

4.6.4 TEST RESULTS

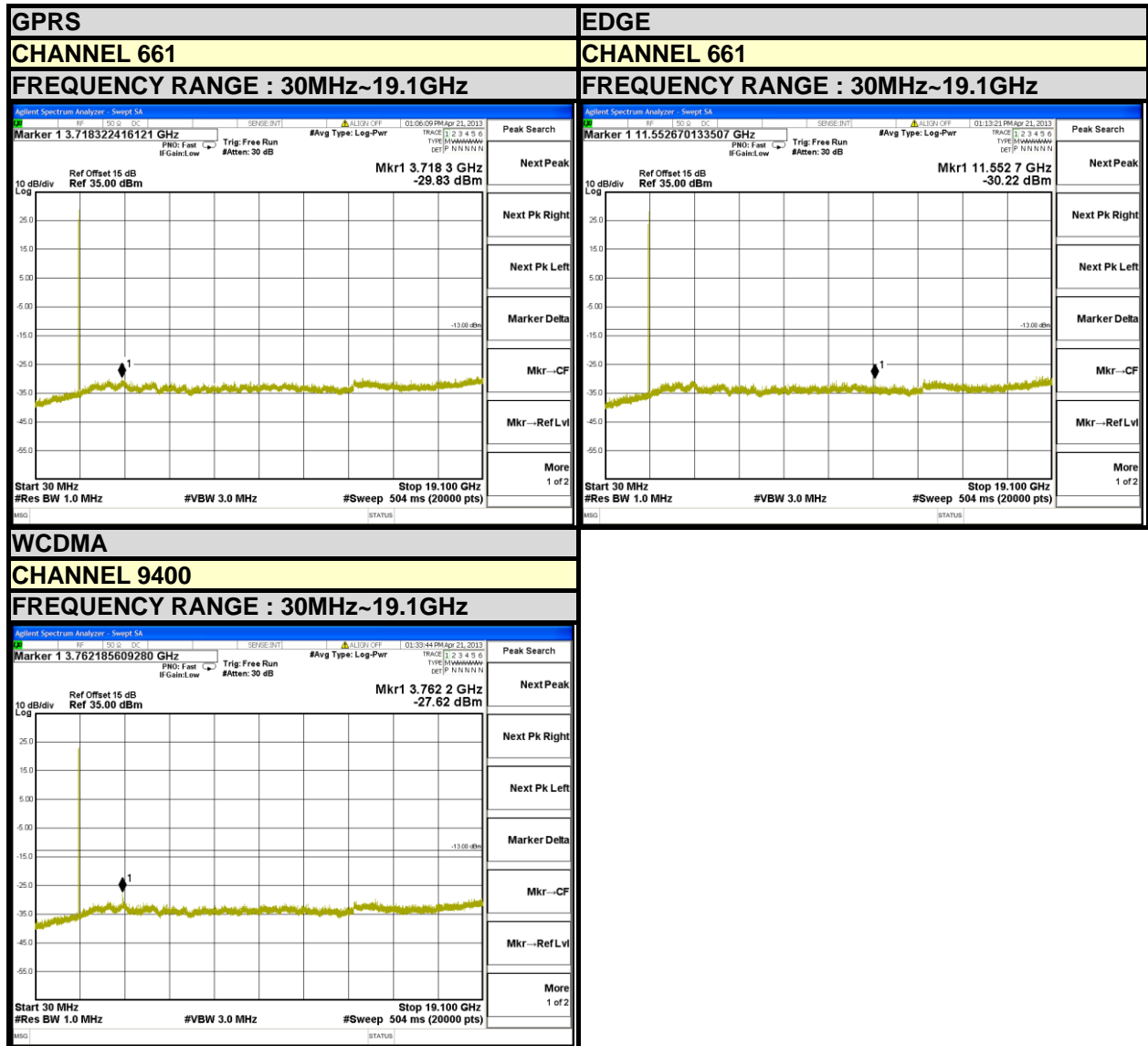



A D T

LTE Band 2 (Channel Bandwidth: 1.4MHz)
CHANNEL 18900
FREQUENCY RANGE : 30MHz~19.1GHz

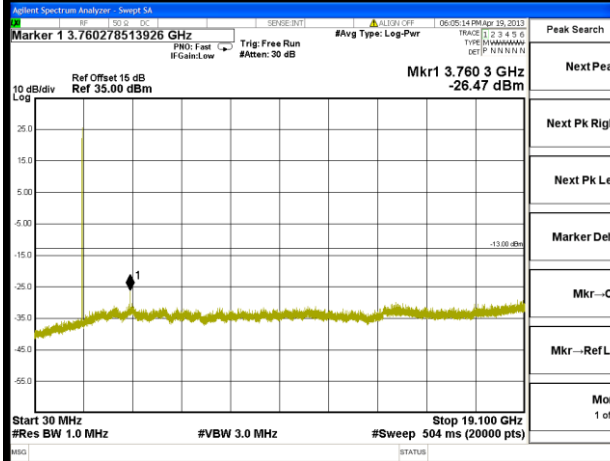

LTE Band 2 (Channel Bandwidth: 3MHz)
CHANNEL 18900
FREQUENCY RANGE : 30MHz~19.1GHz

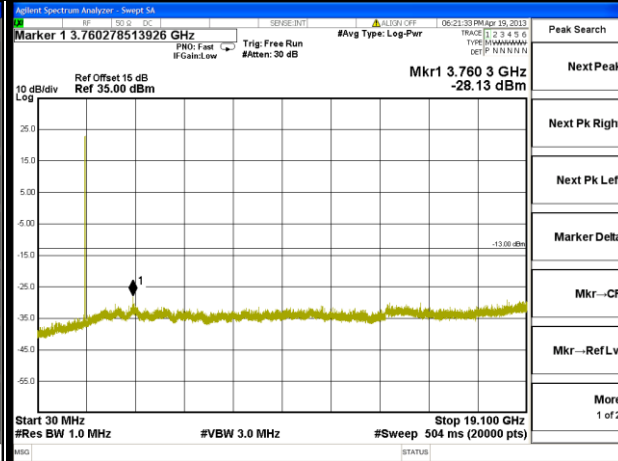

LTE Band 2 (Channel Bandwidth: 5MHz)
CHANNEL 18900
FREQUENCY RANGE : 30MHz~19.1GHz

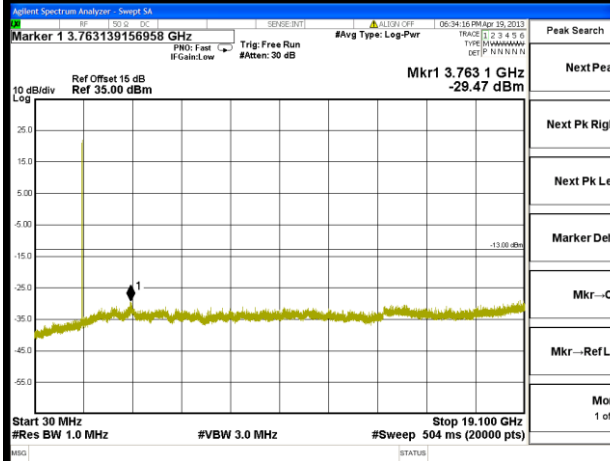

LTE Band 2 (Channel Bandwidth: 10MHz)
CHANNEL 18900
FREQUENCY RANGE : 30MHz~19.1GHz

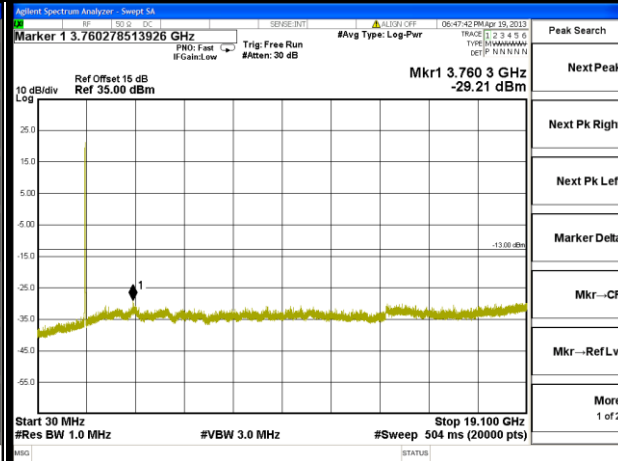

LTE Band 2 (Channel Bandwidth: 15MHz)
CHANNEL 18900
FREQUENCY RANGE : 30MHz~19.1GHz

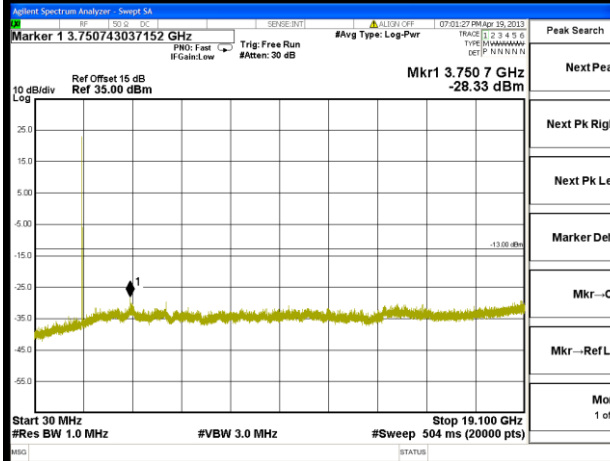

LTE Band 2 (Channel Bandwidth: 20MHz)
CHANNEL 18900
FREQUENCY RANGE : 30MHz~19.1GHz

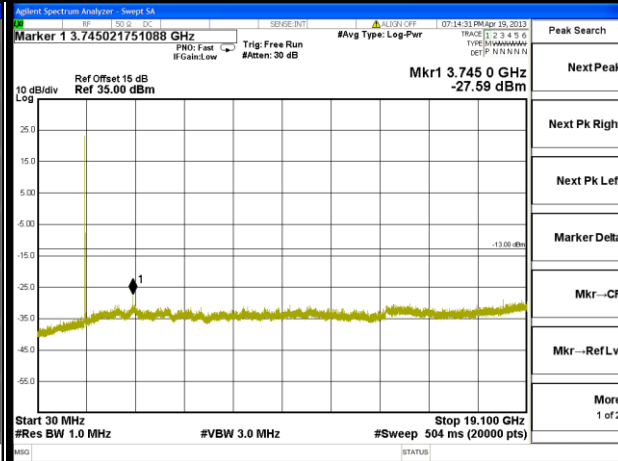

4.7 RADIATED EMISSION MEASUREMENT

4.7.1 LIMITS OF RADIATED EMISSION MEASUREMENT

The power of any emission outside of the authorized operating frequency ranges must be attenuated below the transmitting power (P) by a factor of at least $43 + 10 \log(P)$ dB. The emission limit equal to -13dBm .

4.7.2 TEST PROCEDURES

- a. Substitution method is used for E.I.R.P measurement. In the semi-anechoic chamber, EUT placed on the 0.8m height of Turn Table, rotated the table around 360 degrees to search the maximum radiation power and receiver antenna shall be rotated vertical and horizontal polarization and moved height from 1m to 4m to find the maximum polar radiated power. The “Read Value” is the spectrum reading the maximum power value.
- b. The substitution horn antenna is substituted for EUT at the same position and signals generator export the CW signal to the substitution antenna via a TX cable. Rotated the Turn Table and moved receiving antenna to find the maximum radiation power. Adjust output power level of S.G to get a Value of spectrum reading equal to “Read Value” of step a. Record the power level of S.G
- c. $\text{EIRP} = \text{Output power level of S.G} - \text{TX cable loss} + \text{Antenna gain of substitution horn}$.
- d. E.R.P power can be calculated form E.I.R.P power by subtracting the gain of dipole,
 $\text{E.R.P power} = \text{E.I.R.P power} - 2.15\text{dBi}$.

NOTE: The resolution bandwidth and video bandwidth of test receiver/spectrum analyzer is 1MHz/3MHz.

4.7.3 DEVIATION FROM TEST STANDARD

No deviation

4.7.4 TEST SETUP

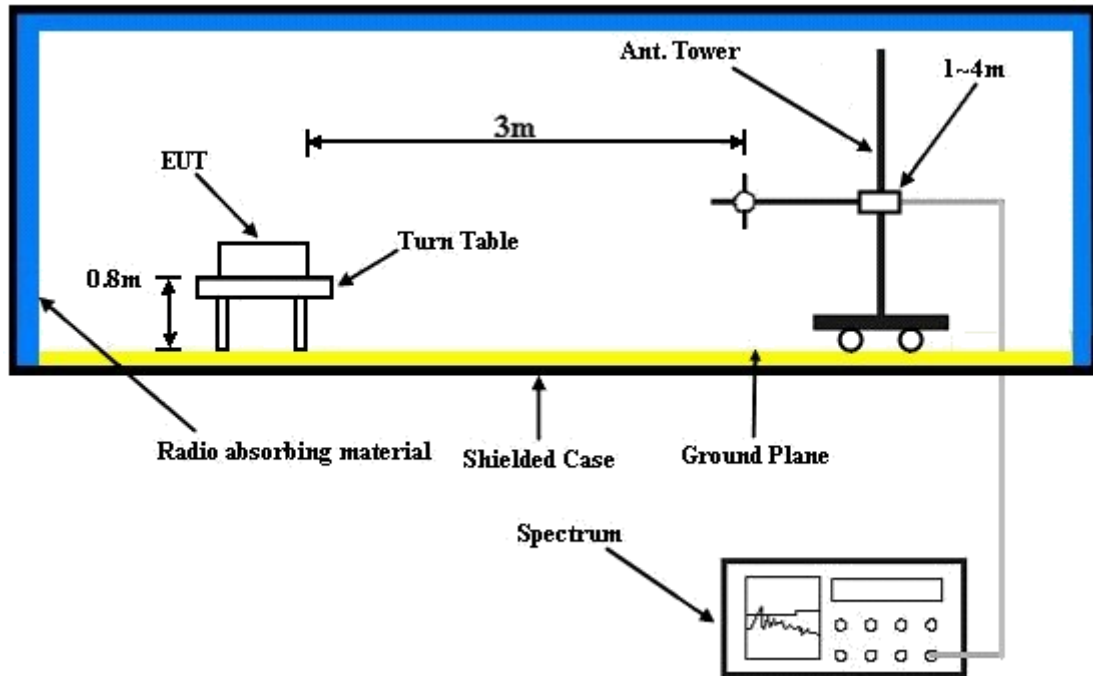

For the actual test configuration, please refer to the attached file (Test Setup Photo).



A D T

4.7.5 TEST RESULTS

GPRS:



Bureau Veritas Consumer Products Services Ltd., Taoyuan Branch

A D T

Data: 15

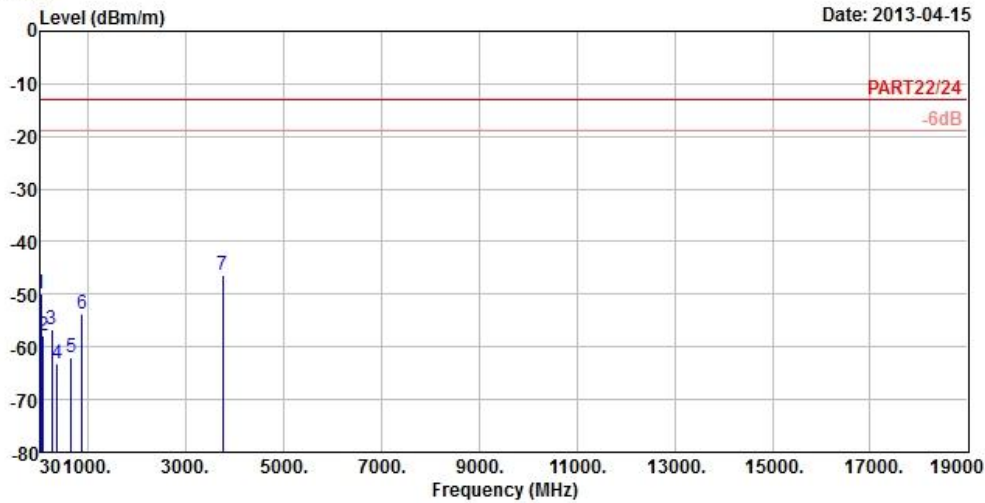

Site : 966 Chamber 5
 Condition : PART22/24 3m HORIZONTAL
 Brand/Model: K005
 Remark : GPRS1900 Link
 Tested by : Johnson Liao
 Temperature : 25°C
 Humidity : 65%
 Plane : Y
 IMEI : 356239051102428

	Read	Limit	Over			
Freq	Level	Level	Line	Limit	Factor	Remark
MHz	dBm/m	dBm	dBm/m	dB	dB/m	
1	30.00	-49.95	-51.02	-13.00	-36.95	1.07 Peak
2	90.48	-57.95	-47.37	-13.00	-44.95	-10.58 Peak
3	261.39	-56.81	-50.97	-13.00	-43.81	-5.84 Peak
4	369.30	-63.20	-57.34	-13.00	-50.20	-5.86 Peak
5	651.40	-61.90	-62.48	-13.00	-48.90	0.58 Peak
6	881.70	-53.65	-56.24	-13.00	-40.65	2.59 Peak
7 pp	3760.00	-46.36	-39.63	-13.00	-33.36	-6.73 Peak



A D T



Bureau Veritas Consumer Products Services Ltd., Taoyuan Branch

A D T

Data: 16

Date: 2013-04-15

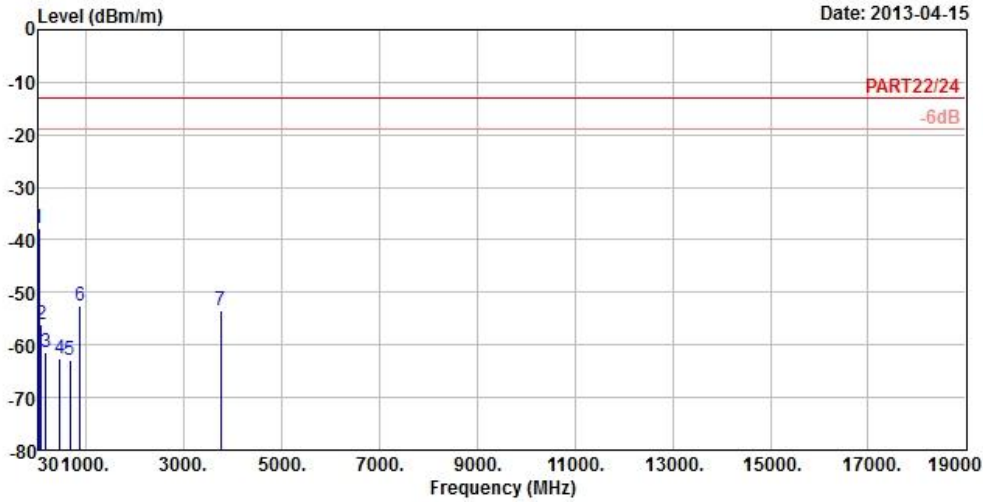

Site : 966 Chamber 5
 Condition : PART22/24 3m VERTICAL
 Brand/Model: K005
 Remark : GPRS1900 Link
 Tested by : Johnson Liao
 Temperature : 25°C
 Humidity : 65%
 Plane : Y
 IMEI : 356239051102428

	Freq	Level	Read Level	Limit Line	Over Limit	Factor	Remark
	MHz	dBm/m	dBm	dBm/m	dB	dB/m	
1	pp	30.81	-37.84	-38.18	-13.00	-24.84	0.34 Peak
2		88.86	-56.16	-45.61	-13.00	-43.16	-10.55 Peak
3		184.98	-61.39	-55.15	-13.00	-48.39	-6.24 Peak
4		462.40	-62.44	-58.39	-13.00	-49.44	-4.05 Peak
5		671.00	-62.97	-63.90	-13.00	-49.97	0.93 Peak
6		880.30	-52.63	-55.22	-13.00	-39.63	2.59 Peak
7		3760.00	-53.47	-46.74	-13.00	-40.47	-6.73 Peak



A D T

EDGE:



Bureau Veritas Consumer Products Services Ltd., Taoyuan Branch

A D T

Data: 15

Date: 2013-04-15

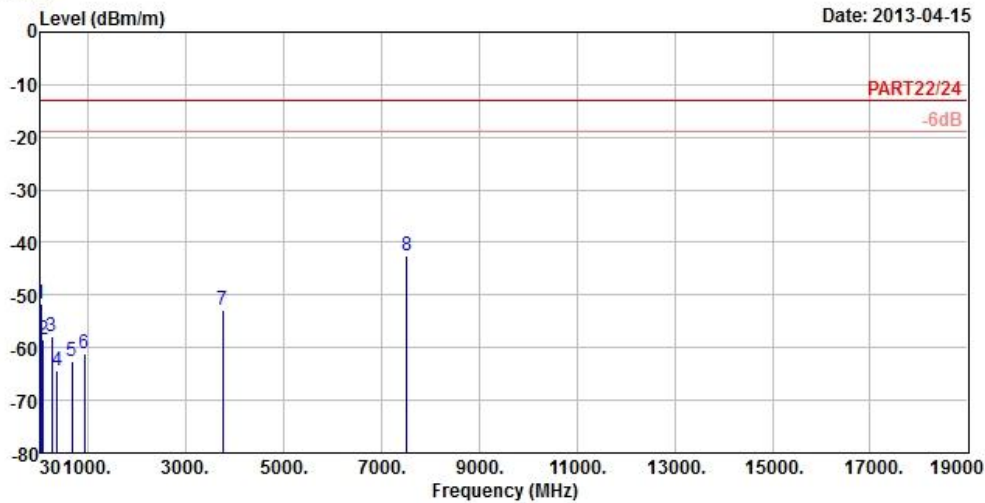

Site : 966 Chamber 5
 Condition : PART22/24 3m HORIZONTAL
 Brand/Model: K005
 Remark : EDGE Link
 Tested by : Johnson Liao
 Temperature : 25°C
 Humidity : 65%
 Plane : Y
 IMEI : 356239051102428

	Freq	Level	Read Level	Limit Line	Over Limit	Factor	Remark
	MHz	dBm/m	dBm	dBm/m	dB	dB/m	
1	30.00	-51.76	-52.83	-13.00	-38.76	1.07	Peak
2	90.21	-58.37	-47.79	-13.00	-45.37	-10.58	Peak
3	256.26	-57.80	-52.04	-13.00	-44.80	-5.76	Peak
4	372.10	-64.26	-58.42	-13.00	-51.26	-5.84	Peak
5	664.70	-62.62	-63.42	-13.00	-49.62	0.80	Peak
6	923.70	-61.21	-64.37	-13.00	-48.21	3.16	Peak
7	3760.00	-52.88	-46.15	-13.00	-39.88	-6.73	Peak
8 pp	7520.00	-42.51	-49.48	-13.00	-29.51	6.97	Peak



A D T



Bureau Veritas Consumer Products Services Ltd., Taoyuan Branch

A D T

Data: 16

Date: 2013-04-15

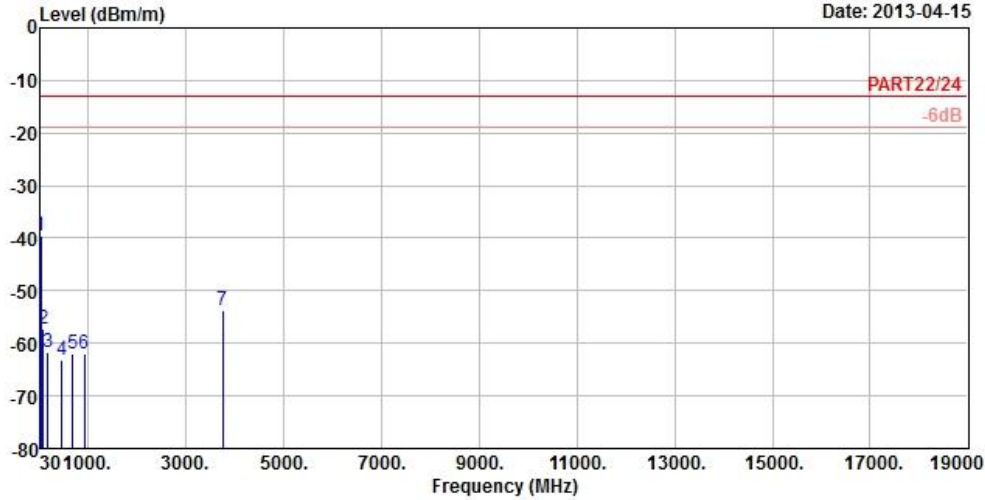

Site : 966 Chamber 5
 Condition : PART22/24 3m VERTICAL
 Brand/Model: K005
 Remark : EDGE Link
 Tested by : Johnson Liao
 Temperature : 25°C
 Humidity : 65%
 Plane : Y
 IMEI : 356239051102428

	Freq	Level	Read Level	Limit Line	Over Limit	Factor	Remark
	MHz	dBm/m	dBm	dBm/m	dB	dB/m	
1	pp	31.35	-39.56	-39.90	-13.00	-26.56	0.34 Peak
2		89.94	-57.15	-46.57	-13.00	-44.15	-10.58 Peak
3		182.28	-61.58	-55.68	-13.00	-48.58	-5.90 Peak
4		460.30	-63.04	-58.94	-13.00	-50.04	-4.10 Peak
5		686.40	-62.00	-63.21	-13.00	-49.00	1.21 Peak
6		932.80	-61.97	-65.32	-13.00	-48.97	3.35 Peak
7		3760.00	-53.85	-47.12	-13.00	-40.85	-6.73 Peak



A D T

WCDMA:



Bureau Veritas Consumer Products Services Ltd., Taoyuan Branch

A D T

Data: 15

Date: 2013-04-15

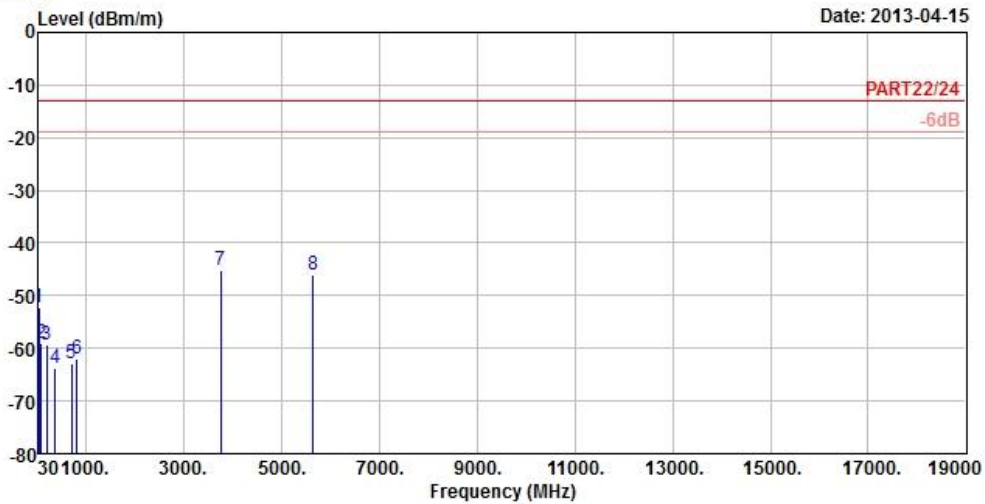

Site : 966 Chamber 5
 Condition : PART22/24 3m HORIZONTAL
 Brand/Model: K005
 Remark : Band II Link
 Tested by : Johnson Liao
 Temperature : 25°C
 Humidity : 65%
 Plane : Y
 IMEI : 356239051102428

	Read	Limit	Over			
Freq	Level	Level	Line	Limit	Factor	Remark
MHz	dBm/m	dBm	dBm/m	dB	dB/m	
1	30.00	-52.11	-53.18	-13.00	-39.11	1.07 Peak
2	89.94	-59.12	-48.54	-13.00	-46.12	-10.58 Peak
3	187.41	-59.24	-52.77	-13.00	-46.24	-6.47 Peak
4	371.40	-63.78	-57.93	-13.00	-50.78	-5.85 Peak
5	704.60	-62.76	-64.24	-13.00	-49.76	1.48 Peak
6	811.00	-62.14	-64.33	-13.00	-49.14	2.19 Peak
7 pp	3760.00	-45.27	-38.54	-13.00	-32.27	-6.73 Peak
8	5640.00	-45.95	-46.16	-13.00	-32.95	0.21 Peak



A D T



Bureau Veritas Consumer Products Services Ltd., Taoyuan Branch

A D T

Data: 16

Date: 2013-04-16

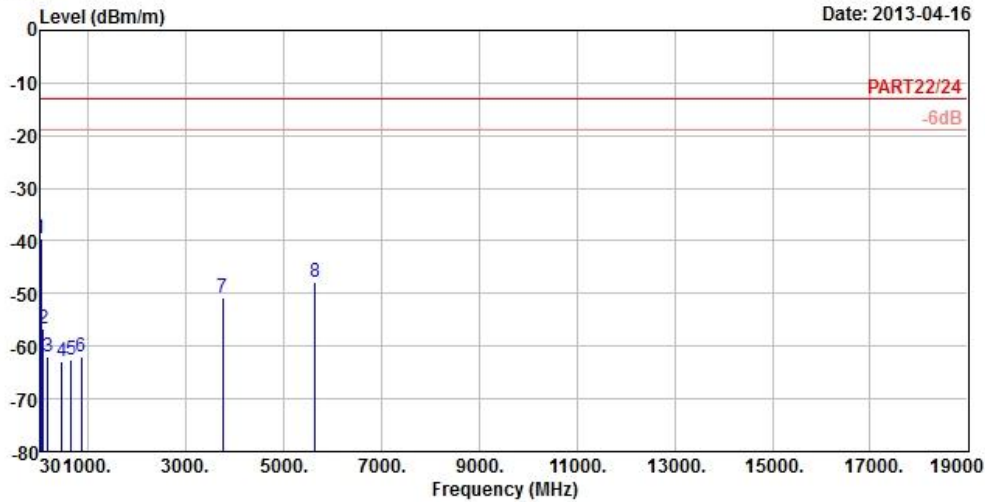

Site : 966 Chamber 5
 Condition : PART22/24 3m VERTICAL
 Brand/Model: K005
 Remark : Band II Link
 Tested by : Johnson Liao
 Temperature : 25°C
 Humidity : 65%
 Plane : Y
 IMEI : 356239051102428

	Freq	Level	Read Level	Limit Line	Over Limit	Factor	Remark
	MHz	dBm/m	dBm	dBm/m	dB	dB/m	
1	pp	31.08	-39.64	-39.98	-13.00	-26.64	0.34 Peak
2		86.43	-56.56	-46.10	-13.00	-43.56	-10.46 Peak
3		181.20	-62.10	-56.32	-13.00	-49.10	-5.78 Peak
4		458.90	-62.83	-58.69	-13.00	-49.83	-4.14 Peak
5		654.90	-62.55	-63.18	-13.00	-49.55	0.63 Peak
6		860.00	-61.90	-64.37	-13.00	-48.90	2.47 Peak
7		3760.00	-50.78	-44.05	-13.00	-37.78	-6.73 Peak
8		5640.00	-47.68	-47.89	-13.00	-34.68	0.21 Peak



A D T

LTE BAND 2

CHANNEL BANDWIDTH: 1.4MHz / QPSK



Bureau Veritas Consumer Products Services Ltd., Taoyuan Branch

A D T

Data: 11

Date: 2013-04-16

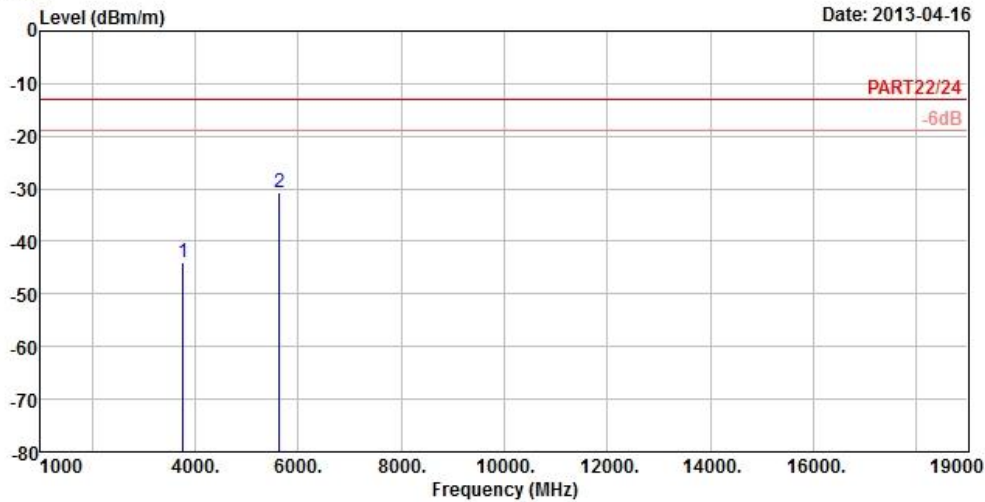

Site : 966 Chamber 5
 Condition : PART22/24 3m HORIZONTAL
 Brand/Model: K005
 Remark : Band 2_1.4M_(QPSK 1,5) Link
 Tested by : Johnson Liao
 Temperature : 25°C
 Humidity : 65%
 Plane : Y
 IMEI : 356239051102428

	Freq	Level	Read Level	Limit Line	Over Limit	Factor	Remark
	MHz	dBm/m	dBm	dBm/m	dB	dB/m	
1	3760.90	-43.86	-37.13	-13.00	-30.86	-6.73	Peak
2	5641.35	-30.67	-30.88	-13.00	-17.67	0.21	Peak



A D T



Bureau Veritas Consumer Products Services Ltd., Taoyuan Branch

A D T

Data: 12

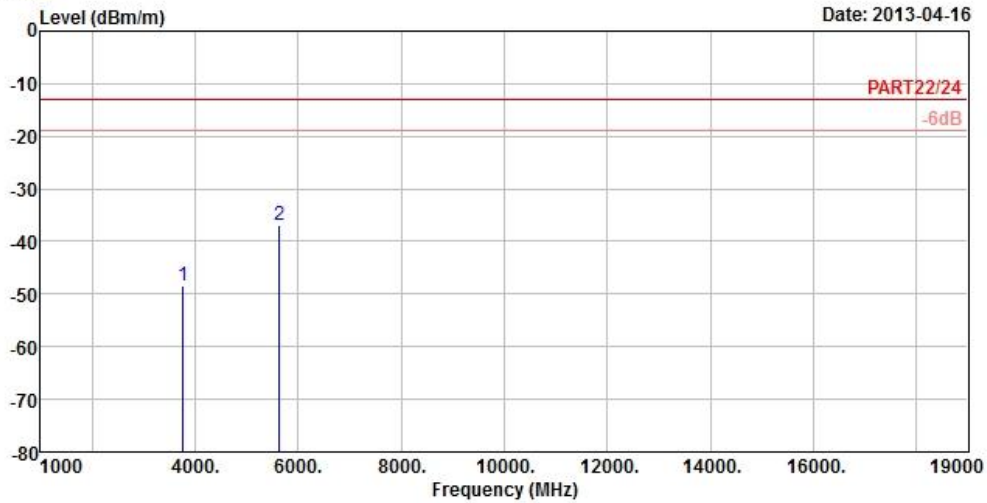

Site : 966 Chamber 5
 Condition : PART22/24 3m VERTICAL
 Brand/Model: K005
 Remark : Band 2_1.4M_(QPSK 1,5) Link
 Tested by : Johnson Liao
 Temperature : 25°C
 Humidity : 65%
 Plane : Y
 IMEI : 356239051102428

	Freq	Level	Read Level	Limit Line	Over Limit	Factor	Remark
	MHz	dBm/m	dBm	dBm/m	dB	dB/m	
1	3760.90	-48.33	-41.60	-13.00	-35.33	-6.73	Peak
2 pp	5641.35	-36.91	-37.12	-13.00	-23.91	0.21	Peak



A D T

LTE BAND 2

CHANNEL BANDWIDTH: 3MHz / QPSK



Bureau Veritas Consumer Products Services Ltd., Taoyuan Branch

A D T

Data: 11

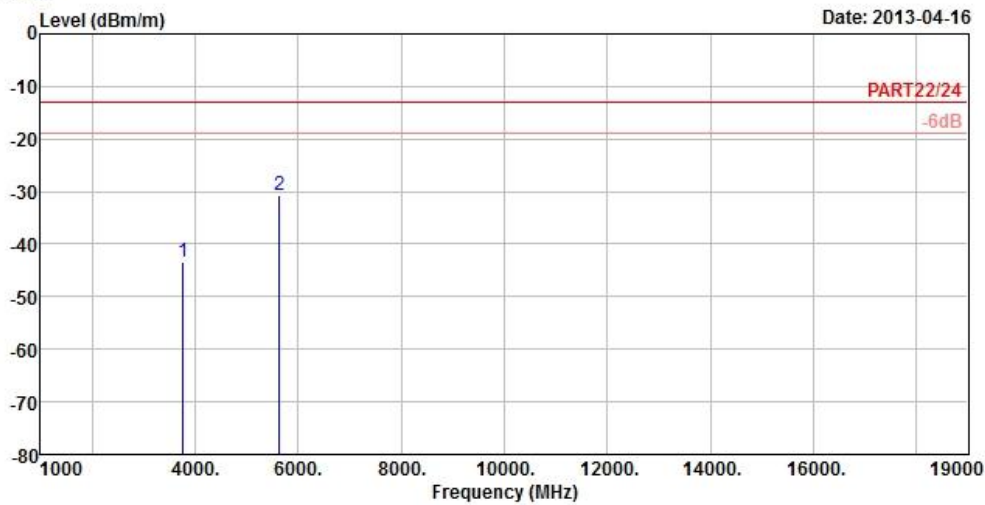

Site : 966 Chamber 5
 Condition : PART22/24 3m HORIZONTAL
 Brand/Model: K005
 Remark : Band 2_3M_(QPSK 1,14) Link
 Tested by : Johnson Liao
 Temperature : 25°C
 Humidity : 65%
 Plane : Y
 IMEI : 356239051102428

	Read	Limit	Over			
Freq	Level	Level	Line	Limit	Factor	Remark
MHz	dBm/m	dBm	dBm/m	dB	dB/m	
1	3760.50	-43.54	-36.81	-13.00	-30.54	-6.73 Peak
2 pp	5640.75	-30.62	-30.83	-13.00	-17.62	0.21 Peak



A D T



Bureau Veritas Consumer Products Services Ltd., Taoyuan Branch

A D T

Data: 12

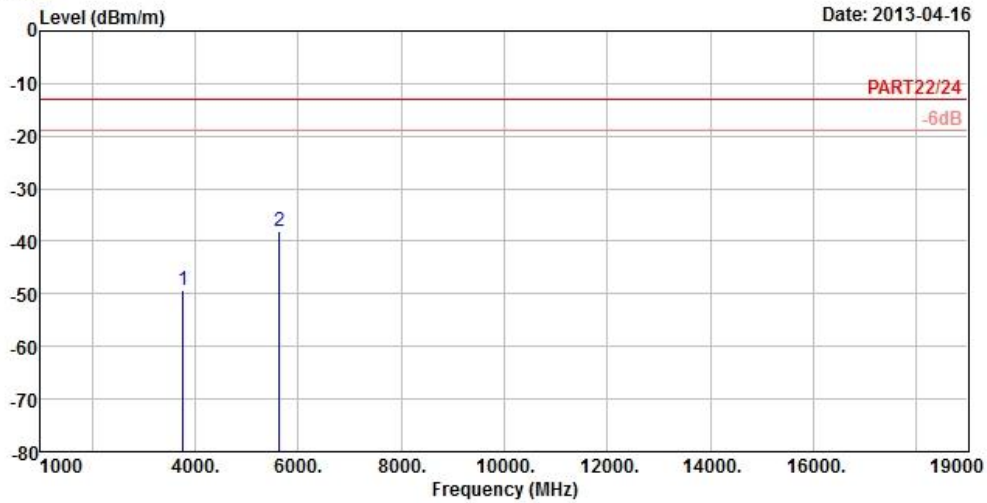

Site : 966 Chamber 5
 Condition : PART22/24 3m VERTICAL
 Brand/Model: K005
 Remark : Band 2_3M_(QPSK 1,14) Link
 Tested by : Johnson Liao
 Temperature : 25°C
 Humidity : 65%
 Plane : Y
 IMEI : 356239051102428

	Freq	Level	Read Level	Limit Line	Over Limit	Factor	Remark
	MHz	dBm/m	dBm	dBm/m	dB	dB/m	
1	3760.50	-49.40	-42.67	-13.00	-36.40	-6.73	Peak
2 pp	5640.75	-38.09	-38.30	-13.00	-25.09	0.21	Peak



A D T

LTE BAND 2

CHANNEL BANDWIDTH: 5MHz / QPSK



Bureau Veritas Consumer Products Services Ltd., Taoyuan Branch

A D T

Data: 11

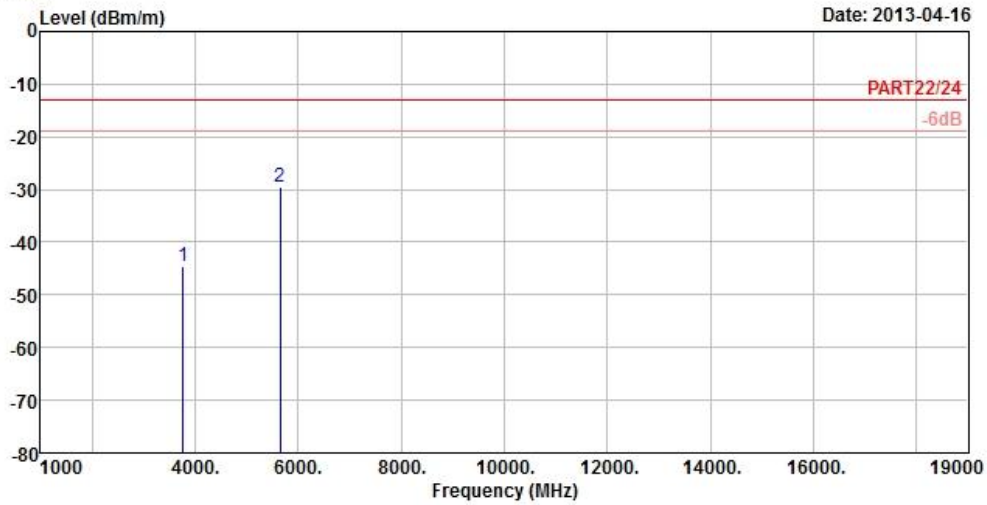

Site : 966 Chamber 5
 Condition : PART22/24 3m HORIZONTAL
 Brand/Model: K005
 Remark : Band 2_5M_(QPSK 1,24) Link
 Tested by : Johnson Liao
 Temperature : 25°C
 Humidity : 65%
 Plane : Y
 IMEI : 356239051102428

	Read	Limit	Over			
Freq	Level	Level	Line	Limit	Factor	Remark
MHz	dBm/m	dBm	dBm/m	dB	dB/m	
1	3764.40	-44.54	-37.93	-13.00	-31.54	-6.61 Peak
2 pp	5646.60	-29.40	-29.61	-13.00	-16.40	0.21 Peak



A D T



Bureau Veritas Consumer Products Services Ltd., Taoyuan Branch

A D T

Data: 12

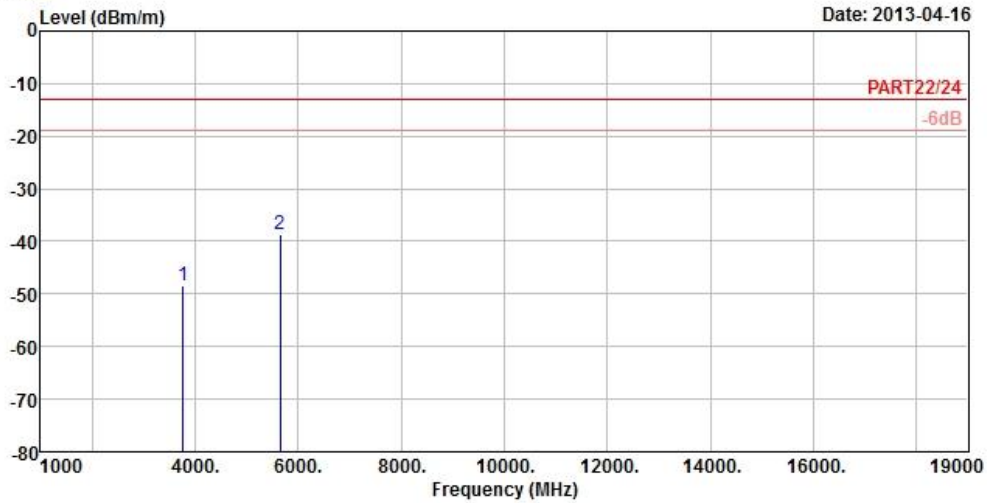

Site : 966 Chamber 5
 Condition : PART22/24 3m VERTICAL
 Brand/Model: K005
 Remark : Band 2_5M_(QPSK 1,24) Link
 Tested by : Johnson Liao
 Temperature : 25°C
 Humidity : 65%
 Plane : Y
 IMEI : 356239051102428

	Read	Limit	Over				
Freq	Level	Level	Line	Limit	Factor	Remark	
MHz	dBm/m	dBm	dBm/m	dB	dB/m		
1	3764.40	-48.33	-41.72	-13.00	-35.33	-6.61	Peak
2	pp 5646.60	-38.73	-38.94	-13.00	-25.73	0.21	Peak



A D T

LTE BAND 2

CHANNEL BANDWIDTH: 10MHz / QPSK



Bureau Veritas Consumer Products Services Ltd., Taoyuan Branch

A D T

Data: 11

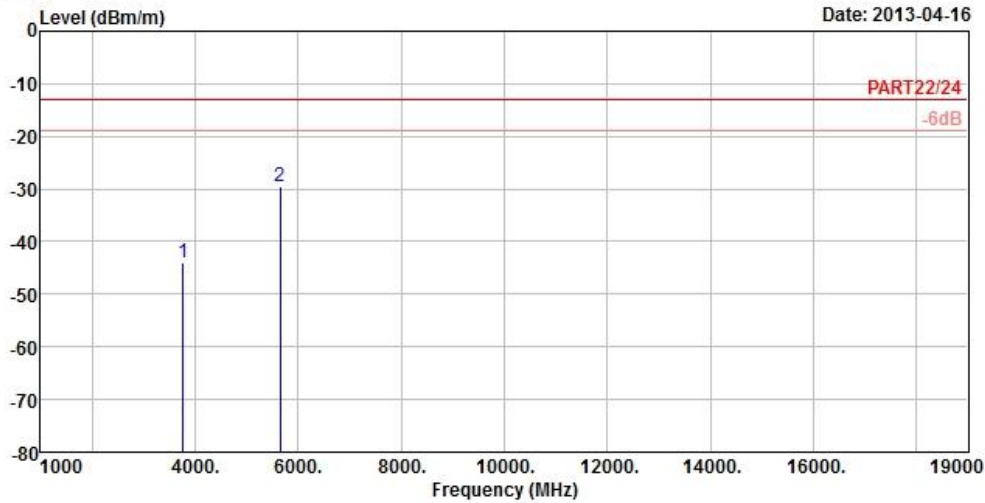

Site : 966 Chamber 5
 Condition : PART22/24 3m HORIZONTAL
 Brand/Model: K005
 Remark : Band 2_10M_(QPSK 1,49) Link
 Tested by : Johnson Liao
 Temperature : 25°C
 Humidity : 65%
 Plane : Y
 IMEI : 356239051102428

	Read	Limit	Over			
Freq	Level	Level	Line	Limit	Factor	Remark
MHz	dBm/m	dBm	dBm/m	dB	dB/m	
1	3768.80	-44.10	-37.49	-13.00	-31.10	-6.61 Peak
2 pp	5653.20	-29.66	-29.85	-13.00	-16.66	0.19 Peak



A D T



Bureau Veritas Consumer Products Services Ltd., Taoyuan Branch

A D T

Data: 12

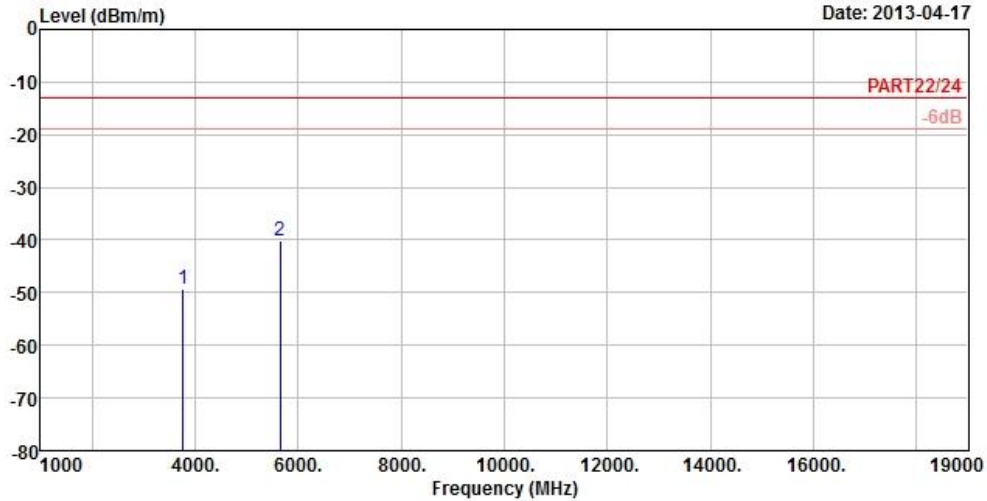

Site : 966 Chamber 5
 Condition : PART22/24 3m VERTICAL
 Brand/Model: K005
 Remark : Band 2_10M_(QPSK 1,49) Link
 Tested by : Johnson Liao
 Temperature : 25°C
 Humidity : 65%
 Plane : Y
 IMEI : 356239051102428

	Freq	Level	Read Level	Limit Line	Over Limit	Factor	Remark
	MHz	dBm/m	dBm	dBm/m	dB	dB/m	
1	3768.80	-49.38	-42.77	-13.00	-36.38	-6.61	Peak
2 pp	5653.20	-40.16	-40.35	-13.00	-27.16	0.19	Peak



A D T

LTE BAND 2

CHANNEL BANDWIDTH: 15MHz / QPSK



Bureau Veritas Consumer Products Services Ltd., Taoyuan Branch

A D T

Data: 15

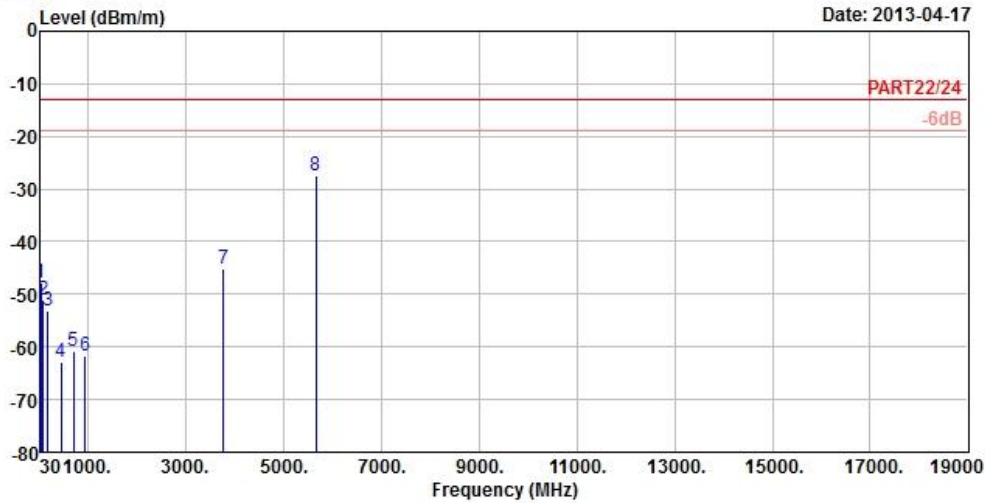

Site : 966 Chamber 5
 Condition : PART22/24 3m HORIZONTAL
 Brand/Model: K005
 Remark : Band 2_15M_(QPSK 1,74) Link
 Tested by : Johnson Liao
 Temperature : 25°C
 Humidity : 65%
 Plane : Y
 IMEI : 356239051102428

	Read	Limit	Over			
Freq	Level	Level	Line	Limit	Factor	Remark
MHz	dBm/m	dBm	dBm/m	dB	dB/m	
1	30.81	-47.73	-48.07	-13.00	-34.73	0.34 Peak
2	89.67	-51.02	-40.44	-13.00	-38.02	-10.58 Peak
3	177.96	-53.03	-46.99	-13.00	-40.03	-6.04 Peak
4	454.70	-62.82	-58.58	-13.00	-49.82	-4.24 Peak
5	699.00	-60.74	-62.17	-13.00	-47.74	1.43 Peak
6	937.70	-61.59	-65.04	-13.00	-48.59	3.45 Peak
7	3773.20	-45.12	-38.51	-13.00	-32.12	-6.61 Peak
8 pp	5659.80	-27.47	-27.66	-13.00	-14.47	0.19 Peak



A D T



Bureau Veritas Consumer Products Services Ltd., Taoyuan Branch

A D T

Data: 16

Date: 2013-04-17

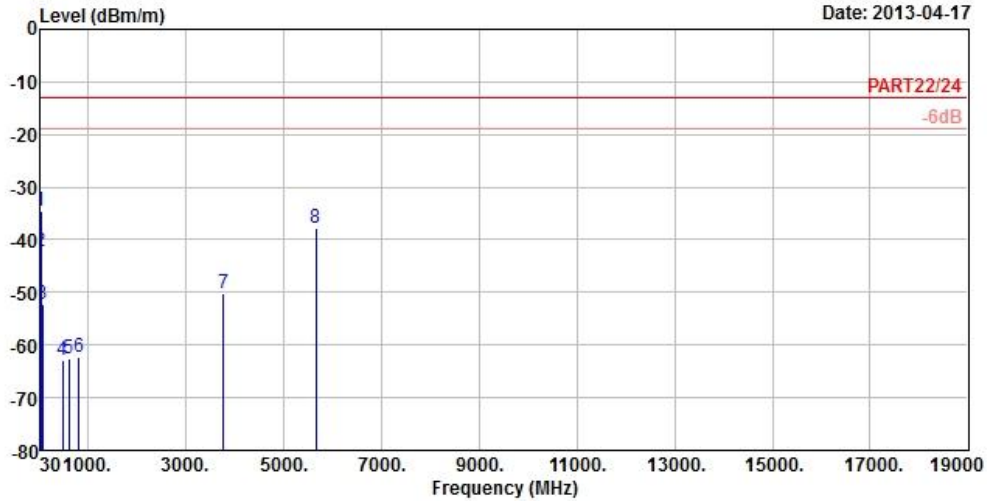

Site : 966 Chamber 5
 Condition : PART22/24 3m VERTICAL
 Brand/Model: K005
 Remark : Band 2_15M_(QPSK 1,74) Link
 Tested by : Johnson Liao
 Temperature : 25°C
 Humidity : 65%
 Plane : Y
 IMEI : 356239051102428

	Read	Limit	Over				
Freq	Level	Level	Line	Limit	Factor	Remark	
MHz	dBm/m	dBm	dBm/m	dB	dB/m		
1 pp	31.35	-34.67	-35.01	-13.00	-21.67	0.34	Peak
2	41.88	-42.26	-40.87	-13.00	-29.26	-1.39	Peak
3	62.40	-52.10	-45.35	-13.00	-39.10	-6.75	Peak
4	479.90	-62.88	-59.28	-13.00	-49.88	-3.60	Peak
5	603.10	-62.58	-62.28	-13.00	-49.58	-0.30	Peak
6	816.60	-62.17	-64.39	-13.00	-49.17	2.22	Peak
7	3773.20	-50.13	-43.52	-13.00	-37.13	-6.61	Peak
8	5659.80	-37.84	-38.03	-13.00	-24.84	0.19	Peak



A D T

LTE BAND 2

CHANNEL BANDWIDTH: 20MHz / QPSK



Bureau Veritas Consumer Products Services Ltd., Taoyuan Branch

A D T

Data: 11

Date: 2013-04-17

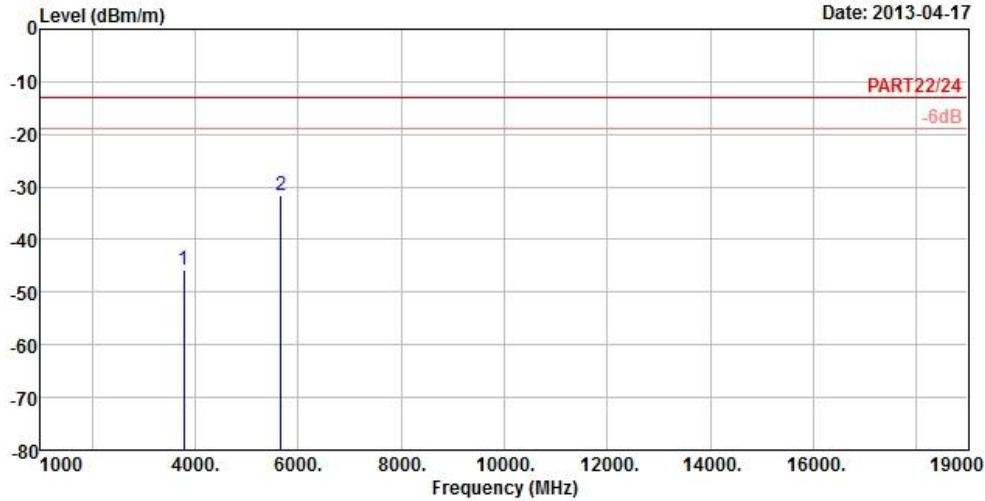

Site : 966 Chamber 5
 Condition : PART22/24 3m HORIZONTAL
 Brand/Model: K005
 Remark : Band 2_20M_(QPSK 1,99) Link
 Tested by : Johnson Liao
 Temperature : 25°C
 Humidity : 65%
 Plane : Y
 IMEI : 356239051102428

	Read	Limit	Over			
Freq	Level	Level	Line	Limit	Factor	Remark
MHz	dBm/m	dBm	dBm/m	dB	dB/m	
1	3777.60	-45.83	-39.22	-13.00	-32.83	-6.61 Peak
2 pp	5666.40	-31.67	-31.86	-13.00	-18.67	0.19 Peak



A D T



Bureau Veritas Consumer Products Services Ltd., Taoyuan Branch

A D T

Data: 12

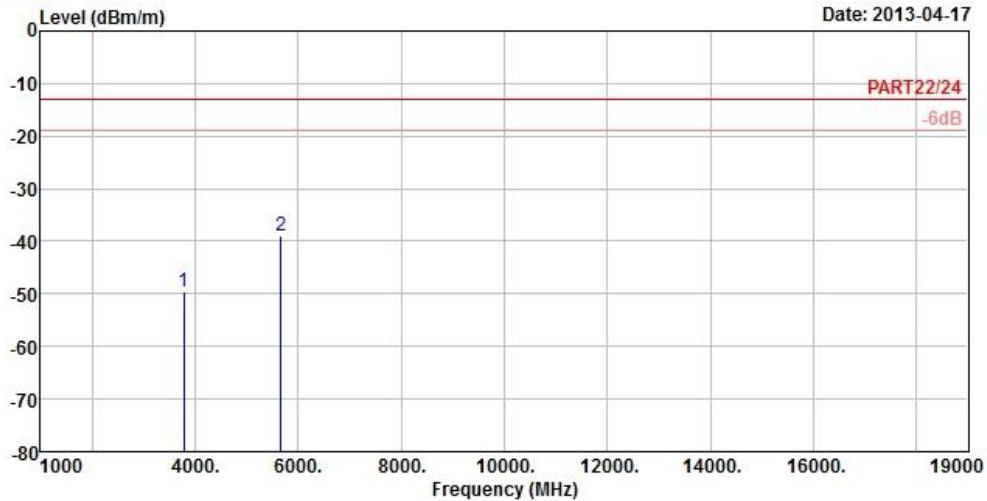

Site : 966 Chamber 5
 Condition : PART22/24 3m VERTICAL
 Brand/Model: K005
 Remark : Band 2_20M_(QPSK 1,99) Link
 Tested by : Johnson Liao
 Temperature : 25°C
 Humidity : 65%
 Plane : Y
 IMEI : 356239051102428

	Freq	Level	Read Level	Limit Line	Over Limit	Factor	Remark
	MHz	dBm/m	dBm	dBm/m	dB	dB/m	
1	3777.60	-49.70	-43.09	-13.00	-36.70	-6.61	Peak
2	5666.40	-38.97	-39.16	-13.00	-25.97	0.19	Peak



5 PHOTOGRAPHS OF THE TEST CONFIGURATION

Please refer to the attached file (Test Setup Photo).



A D T

6 INFORMATION ON THE TESTING LABORATORIES

We, Bureau Veritas Consumer Products Services (H.K.) Ltd., Taoyuan Branch, were founded in 1988 to provide our best service in EMC, Radio, Telecom and Safety consultation. Our laboratories are accredited and approved according to ISO/IEC 17025.

If you have any comments, please feel free to contact us at the following:

Linko EMC/RF Lab:

Tel: 886-2-26052180

Fax: 886-2-26051924

Hsin Chu EMC/RF Lab:

Tel: 886-3-5935343

Fax: 886-3-5935342

Hwa Ya EMC/RF/Safety/Telecom Lab:

Tel: 886-3-3183232

Fax: 886-3-3270892

Email: service.adt@tw.bureauveritas.com

Web Site: www.bureauveritas-adt.com

The address and road map of all our labs can be found in our web site also.



A D T

7 APPENDIX A – MODIFICATIONS RECORDERS FOR ENGINEERING CHANGES TO THE EUT BY THE LAB

No any modifications were made to the EUT by the lab during the test.

---END---