

## FCC Test Report (Part 24)

**Report No.:** RF190114C07-7

**FCC ID:** MSQI01WD

**Test Model:** ASUS\_I01WD

**Received Date:** Jan. 14, 2019

**Test Date:** Jan. 22 ~ Feb. 13, 2019

**Issued Date:** Feb. 20, 2019

**Applicant:** ASUSTek COMPUTER INC.

**Address:** 4F, No. 150, LI-TE Rd., PEITOU, TAIPEI 112, TAIWAN

**Issued By:** Bureau Veritas Consumer Products Services (H.K.) Ltd., Taoyuan Branch

**Lab Address:** No. 47-2, 14th Ling, Chia Pau Vil., Lin Kou Dist., New Taipei City, Taiwan  
(R.O.C.)

**Test Location:** No. 19, Hwa Ya 2nd Rd., Wen Hwa Vil., Kwei Shan Dist., Taoyuan City  
33383, TAIWAN (R.O.C.)

**FCC Registration /** 788550 / TW0003

**Designation Number:**



This report is for your exclusive use. Any copying or replication of this report to or for any other person or entity, or use of our name or trademark, is permitted only with our prior written permission. This report sets forth our findings solely with respect to the test samples identified herein. The results set forth in this report are not indicative or representative of the quality or characteristics of the lot from which a test sample was taken or any similar or identical product unless specifically and expressly noted. Our report includes all of the tests requested by you and the results thereof based upon the information that you provided to us. You have 60 days from date of issuance of this report to notify us of any material error or omission caused by our negligence, provided, however, that such notice shall be in writing and shall specifically address the issue you wish to raise. A failure to raise such issue within the prescribed time shall constitute your unqualified acceptance of the completeness of this report, the tests conducted and the correctness of the report contents. Unless specific mention, the uncertainty of measurement has been explicitly taken into account to declare the compliance or non-compliance to the specification. The report must not be used by the client to claim product certification, approval, or endorsement by TAF or any government agencies

## Table of Contents

<b>Release Control Record</b> .....	<b>4</b>
<b>1 Certificate of Conformity</b> .....	<b>5</b>
<b>2 Summary of Test Results</b> .....	<b>6</b>
2.1 Measurement Uncertainty.....	6
2.2 Test Site and Instruments.....	7
<b>3 General Information</b> .....	<b>8</b>
3.1 General Description of EUT.....	8
3.2 Configuration of System under Test.....	10
3.2.1 Description of Support Units.....	10
3.3 Test Mode Applicability and Tested Channel Detail.....	11
3.4 EUT Operating Conditions.....	16
3.5 General Description of Applied Standards.....	16
<b>4 Test Types and Results</b> .....	<b>17</b>
4.1 Output Power Measurement.....	17
4.1.1 Limits of Output Power Measurement.....	17
4.1.2 Test Procedures.....	17
4.1.3 Test Setup.....	18
4.1.4 Test Results.....	19
4.2 Modulation Characteristics Measurement.....	46
4.2.1 Limits of Modulation Characteristics.....	46
4.2.2 Test Procedure.....	46
4.2.3 Test Setup.....	46
4.2.4 Test Results.....	47
4.3 Frequency Stability Measurement.....	50
4.3.1 Limits of Frequency Stability Measurement.....	50
4.3.2 Test Procedure.....	50
4.3.3 Conducted Setup.....	50
4.3.4 Test Results.....	51
4.4 Occupied Bandwidth Measurement.....	60
4.4.1 Test Procedure.....	60
4.4.2 Test Setup.....	60
4.4.3 Test Result.....	61
4.5 Band Edge Measurement.....	71
4.5.1 Limits of Band Edge Measurement.....	71
4.5.2 Test Setup.....	71
4.5.3 Test Procedures.....	71
4.5.4 Test Results.....	72
4.6 Peak to Average Ratio.....	80
4.6.1 Limits of Peak to Average Ratio Measurement.....	80
4.6.2 Test Setup.....	80
4.6.3 Test Procedures.....	80
4.6.4 Test Results.....	81
4.7 Conducted Spurious Emissions.....	86
4.7.1 Limits of Conducted Spurious Emissions Measurement.....	86
4.7.2 Test Setup.....	86
4.7.3 Test Procedure.....	86
4.7.4 Test Results.....	87
4.8 Radiated Emission Measurement.....	123
4.8.1 Limits of Radiated Emission Measurement.....	123
4.8.2 Test Procedure.....	123
4.8.3 Deviation from Test Standard.....	123
4.8.4 Test Setup.....	124
4.8.5 Test Results.....	125

<b>5</b>	<b>Pictures of Test Arrangements.....</b>	<b>141</b>
	<b>Appendix – Information on the Testing Laboratories .....</b>	<b>142</b>

### Release Control Record

Issue No.	Description	Date Issued
RF190114C07-7	Original release	Feb. 20, 2019

## 1 Certificate of Conformity

**Product:** ASUS Phone

**Brand:** ASUS

**Test Model:** ASUS\_I01WD

**Sample Status:** Identical Prototype

**Applicant:** ASUSTek COMPUTER INC.

**Test Date:** Jan. 22 ~ Feb. 13, 2019

**Standards:** FCC Part 24, Subpart E

The above equipment has been tested by **Bureau Veritas Consumer Products Services (H.K.) Ltd., Taoyuan Branch**, and found compliance with the requirement of the above standards. The test record, data evaluation & Equipment Under Test (EUT) configurations represented herein are true and accurate accounts of the measurements of the sample's RF characteristics under the conditions specified in this report.

**Prepared by :** Celine Chou , **Date:** Feb. 20, 2019  
Celine Chou / Senior Specialist

**Approved by :** Bruce Chen , **Date:** Feb. 20, 2019  
Bruce Chen / Project Engineer

## 2 Summary of Test Results

Applied Standard: FCC Part 24 & Part 2			
FCC Clause	Test Item	Result	Remarks
2.1046 24.232	Effective radiated power	Pass	Meet the requirement of limit.
2.1046 24.232(d)	Peak To Average Ratio	Pass	Meet the requirement of limit.
2.1047	Modulation Characteristics	Pass	Meet the requirement
2.1055 24.235	Frequency Stability	Pass	Meet the requirement of limit.
2.1049	Occupied Bandwidth	Pass	Meet the requirement of limit.
24.238	Band Edge Measurements	Pass	Meet the requirement of limit.
2.1051 24.238	Conducted Spurious Emissions	Pass	Meet the requirement of limit.
2.1053 24.238	Radiated Spurious Emissions	Pass	Meet the requirement of limit. Minimum passing margin is -33.40dB at 31.94MHz.

Note: Determining compliance based on the results of the compliance measurement, not taking into account measurement instrumentation uncertainty.

### 2.1 Measurement Uncertainty

Where relevant, the following measurement uncertainty levels have been estimated for tests performed on the EUT as specified in CISPR 16-4-2:

Measurement	Frequency	Expanded Uncertainty (k=2) ( $\pm$ )
Radiated Emissions up to 1 GHz	30MHz ~ 200MHz	3.63 dB
	200MHz ~ 1000MHz	3.64 dB
Radiated Emissions above 1 GHz	1GHz ~ 18GHz	2.29 dB
	18GHz ~ 40GHz	2.29 dB

## 2.2 Test Site and Instruments

Description & Manufacturer	Model No.	Serial No.	Cal. Date	Cal. Due
Test Receiver ROHDE & SCHWARZ	ESCI	100424	Jan. 03, 2019	Jan. 02, 2020
Spectrum Analyzer ROHDE & SCHWARZ	FSP40	100040	Sep. 25, 2018	Sep. 24, 2019
Spectrum Analyzer KEYSIGHT	N9030B	MY57140953	Jul. 02, 2018	Jul. 01, 2019
BILOG Antenna SCHWARZBECK	VULB9168	9168-155	Nov. 21, 2018	Nov. 20, 2019
HORN Antenna SCHWARZBECK	9120D	9120D-408	Nov. 25, 2018	Nov. 24, 2019
HORN Antenna SCHWARZBECK	BBHA 9170	BBHA9170241	Nov. 25, 2018	Nov. 24, 2019
Loop Antenna TESEQ	HLA 6121	45745	Jun. 14, 2018	Jun. 13, 2019
Preamplifier Agilent (Below 1GHz)	8447D	2944A10631	Aug. 08, 2018	Aug. 07, 2019
Preamplifier KEYSIGHT (Above 1GHz)	83017A	MY53270295	Jul. 02, 2018	Jul. 01, 2019
RF signal cable HUBER+SUHNER	SUCOFLEX 104	MY 13380+295012/04	Aug. 08, 2018	Aug. 07, 2019
RF signal cable HUBER+SUHNER	SUCOFLEX 104	Cable-CH4-03 (250724)	Aug. 08, 2018	Aug. 07, 2019
RF signal cable WOKEN	8D-FB	Cable-CH4-01	Aug. 29, 2018	Aug. 28, 2019
Software BV ADT	ADT_Radiated_ V7.6.15.9.5	NA	NA	NA
Antenna Tower inn-co GmbH	MA 4000	010303	NA	NA
Antenna Tower Controller BV ADT	AT100	AT93021703	NA	NA
Turn Table BV ADT	TT100	TT93021703	NA	NA
Turn Table Controller BV ADT	SC100	SC93021703	NA	NA
Boresight Antenna Fixture	FBA-01	FBA-SIP01	NA	NA
Pre-amplifier (18GHz-40GHz) EMC	EMC184045B	980175	Nov. 14, 2018	Nov. 13, 2019
WIT Standard Temperature And Humidity Chamber	TH-4S-C	W981030	Jun. 04, 2018	Jun. 03, 2019
JFW 20dB attenuation	50HF-020-SMA	NA	NA	NA

- Note: 1. The calibration interval of the above test instruments is 12 months and the calibrations are traceable to NML/ROC and NIST/USA.  
2. The test was performed in HwaYa Chamber 4.  
3. The FCC Designation Number is TW0003. The number will be varied with the Lab location and scope as attached.  
4. The IC Site Registration No. is 7450F-4.

### 3 General Information

#### 3.1 General Description of EUT

Product	ASUS Phone			
Brand	ASUS			
Test Model	ASUS_I01WD			
Sample Status	Identical Prototype			
Power Supply Rating	3.85 Vdc (Battery) 5 or 9 Vdc (Adapter) 5 Vdc (Host equipment)			
Modulation Type	GSM, GPRS: GMSK EDGE: 8PSK WCDMA: BPSK, QPSK HSDPA: BPSK HSUPA: QPSK LTE: QPSK, 16QAM, 64QAM			
Operating Frequency	GSM/GPRS/EDGE	1850.2~1909.8MHz		
	WCDMA Band 2	1852.4~1907.6MHz		
	LTE Band 2 (Channel Bandwidth 1.4MHz)	1850.7~1909.3MHz		
	LTE Band 2 (Channel Bandwidth 3MHz)	1851.5~1908.5MHz		
	LTE Band 2 (Channel Bandwidth 5MHz)	1852.5~1907.5MHz		
	LTE Band 2 (Channel Bandwidth 10MHz)	1855.0~1905.0MHz		
	LTE Band 2 (Channel Bandwidth 15MHz)	1857.5~1902.5MHz		
	LTE Band 2 (Channel Bandwidth 20MHz)	1860.0~1900.0MHz		
Max. EIRP Power	GSM	144.544mW (21.60dBm)		
	WCDMA Band 2	194.984mW (22.90dBm)		
		QPSK	16QAM	64QAM
	LTE Band 2 (Channel Bandwidth 1.4MHz)	114.815mW (20.60dBm)	93.325mW (19.70dBm)	81.283mW (19.10dBm)
	LTE Band 2 (Channel Bandwidth 3MHz)	117.490mW (20.70dBm)	97.724mW (19.90dBm)	85.114mW (19.30dBm)
	LTE Band 2 (Channel Bandwidth 5MHz)	123.027mW (20.90dBm)	102.329mW (20.10dBm)	85.114mW (19.30dBm)
	LTE Band 2 (Channel Bandwidth 10MHz)	104.713mW (20.20dBm)	91.201mW (19.60dBm)	74.131mW (18.70dBm)
	LTE Band 2 (Channel Bandwidth 15MHz)	114.815mW (20.60dBm)	120.226mW (20.80dBm)	102.329mW (20.10dBm)
	LTE Band 2 (Channel Bandwidth 20MHz)	117.490mW (20.70dBm)	100.000mW (20.00dBm)	83.176mW (19.20dBm)



Emission Designator	GSM/GPRS	240KGXW		
	EDGE	240KG7W		
	WCDMA Band 2	4M15F9W		
		QPSK	16QAM	64QAM
	LTE Band 2 (Channel Bandwidth 1.4MHz)	1M09G7D	1M09D7W	1M09D7W
	LTE Band 2 (Channel Bandwidth 3MHz)	2M70G7D	2M70D7W	2M70D7W
	LTE Band 2 (Channel Bandwidth 5MHz)	4M50G7D	4M49D7W	4M50D7W
	LTE Band 2 (Channel Bandwidth 10MHz)	8M98G7D	8M98D7W	8M98D7W
	LTE Band 2 (Channel Bandwidth 15MHz)	13M5G7D	13M5D7W	13M5D7W
	LTE Band 2 (Channel Bandwidth 20MHz)	18M0G7D	18M0D7W	18M0D7W
Antenna Type	Refer to Note as below			
Antenna Connector	Refer to Note as below			
Accessory Device	Refer to Note as below			
Cable Supplied	Refer to Note as below			

Note:

1. The EUT accessories list refers to EUT Photo.pdf.
2. The following antennas were provided to the EUT.

Ant. No.	Type	Connector	Gain (dBi)											
			GSM 850	GSM 1900	WCDMA B2	WCDMA B4	WCDMA B5	LTE B2	LTE B4	LTE B5	LTE B7	LTE B26	LTE B38	LTE B41
WWAN Antenna-0	PIFA	NA	-4.5	-2.6	-2.6	-1.9	-4.5	-2.5	-1.9	-4.5	-1.3	-4.4	-1.0	-1.0
WWAN Antenna-1	PIFA	NA	-3.4	-3.2	-3.2	-5.3	-3.4	-3.2	-5.3	-3.3	-4.7	-3.3	-5.7	-5.7

### 3.2 Configuration of System under Test

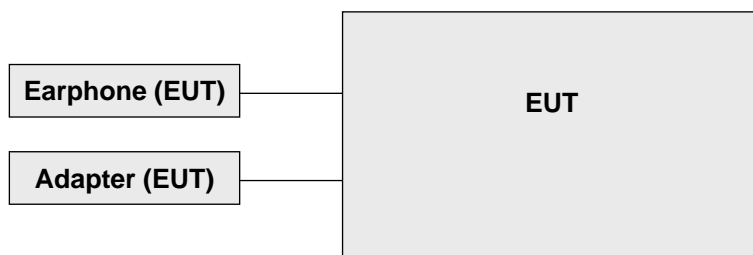

-----  
Remote site

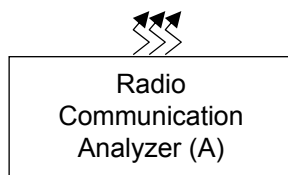

#### 3.2.1 Description of Support Units

The EUT has been tested as an independent unit together with other necessary accessories or support units. The following support units or accessories were used to form a representative test configuration during the tests.

ID	Product	Brand	Model No.	Serial No.	FCC ID	Remarks
A.	Radio Communication Analyzer	Anritsu	MT8860C	1702001	NA	-

Note:

1. All power cords of the above support units are non-shielded (1.8m).
2. Item A acted as a communication partner to transfer data.

### 3.3 Test Mode Applicability and Tested Channel Detail

Pre-Scan has been conducted to determine the worst-case mode from all possible combinations between available modulations, data rates, XYZ axis and antenna ports. The worst case was found when positioned on Z-plane. Following channel(s) was (were) selected for the final test as listed below.

#### GSM Mode

EUT Configure Mode	Test Item	Available Channel	Tested Channel	Mode
-	EIRP	512 to 810	512(1850.2MHz), 661(1880.0MHz), 810(1909.8MHz)	GSM
-	Modulation characteristics	512 to 810	661(1880.0MHz)	GSM, GPRS, EDGE
-	Frequency Stability	512 to 810	512(1850.2MHz), 810(1909.8MHz)	GSM
-	Occupied Bandwidth	512 to 810	512(1850.2MHz), 661(1880.0MHz), 810(1909.8MHz)	GSM, GPRS, EDGE
-	Band Edge	512 to 810	512(1850.2MHz), 810(1909.8MHz)	GSM, GPRS, EDGE
-	Peak To Average Ratio	512 to 810	512(1850.2MHz), 661(1880.0MHz), 810(1909.8MHz)	GSM, GPRS, EDGE
-	Conducted Emission	512 to 810	512(1850.2MHz), 661(1880.0MHz), 810(1909.8MHz)	GSM, GPRS, EDGE
-	Radiated Emission Below 1GHz	512 to 810	661(1880.0MHz)	GSM
-	Radiated Emission Above 1GHz	512 to 810	512(1850.2MHz), 661(1880.0MHz), 810(1909.8MHz)	GSM

Note: For radiated emission below 1GHz, low, mid and high channels were pre-tested E.I.R.P. in chamber. Middle channel was found to be the worst case and therefore had been chosen for all final tests.

### WCDMA Band 2

EUT Configure Mode	Test Item	Available Channel	Tested Channel	Mode
-	EIRP	9262 to 9538	9262 (1852.4MHz), 9400 (1880.0MHz), 9538 (1907.6MHz)	WCDMA
-	Modulation Characteristics	9262 to 9538	9400 (1880.0MHz)	WCDMA, HSDPA, HSUPA
-	Frequency Stability	9262 to 9538	9262 (1852.4MHz), 9538 (1907.6MHz)	WCDMA
-	Occupied Bandwidth	9262 to 9538	9262 (1852.4MHz), 9400 (1880.0MHz), 9538 (1907.6MHz)	WCDMA, HSDPA, HSUPA
-	Band Edge	9262 to 9538	9262 (1852.4MHz), 9538 (1907.6MHz)	WCDMA, HSDPA, HSUPA
-	Peak To Average Ratio	9262 to 9538	9262 (1852.4MHz), 9400 (1880.0MHz), 9538 (1907.6MHz)	WCDMA, HSDPA, HSUPA
-	Conducted Emission	9262 to 9538	9262 (1852.4MHz), 9400 (1880.0MHz), 9538 (1907.6MHz)	WCDMA, HSDPA, HSUPA
-	Radiated Emission Below 1GHz	9262 to 9538	9538 (1907.6MHz)	WCDMA
-	Radiated Emission Above 1GHz	9262 to 9538	9262 (1852.4MHz), 9400 (1880.0MHz), 9538 (1907.6MHz)	WCDMA

Note: For radiated emission below 1GHz, low, mid and high channels were pre-tested E.I.R.P. in chamber. Middle channel was found to be the worst case and therefore had been chosen for all final tests.

LTE Band 2

EUT Configure Mode	Test item	Available channel	Tested Channel	Channel Bandwidth	Modulation	Mode
-	EIRP	18607 to 19193	18607 (1850.70MHz), 18900 (1880.00MHz), 19193 (1909.30MHz)	1.4MHz	QPSK / 16QAM / 64QAM	1 RB / 0 RB Offset
		18615 to 19185	18615 (1851.50MHz), 18900 (1880.00MHz), 19185 (1908.50MHz)	3MHz	QPSK / 16QAM / 64QAM	1 RB / 0 RB Offset
		18625 to 19175	18625 (1852.50MHz), 18900 (1880.00MHz), 19175 (1907.50MHz)	5MHz	QPSK / 16QAM / 64QAM	1 RB / 0 RB Offset
		18650 to 19150	18650 (1855.00MHz), 18900 (1880.00MHz), 19150 (1905.00MHz)	10MHz	QPSK / 16QAM / 64QAM	1 RB / 0 RB Offset
		18675 to 19125	18675 (1857.50MHz), 18900 (1880.00MHz), 19125 (1902.50MHz)	15MHz	QPSK / 16QAM / 64QAM	1 RB / 0 RB Offset
		18700 to 19100	18700 (1860.00MHz), 18900 (1880.00MHz), 19100 (1900.00MHz)	20MHz	QPSK / 16QAM / 64QAM	1 RB / 0 RB Offset
-	Modulation Characteristics	18700 to 19100	18900 (1880.00MHz)	20MHz	QPSK / 16QAM / 64QAM	100 RB / 0 RB Offset
-	Frequency Stability	18607 to 19193	18607 (1850.70MHz), 19193 (1909.30MHz)	1.4MHz	QPSK	1 RB / 0 RB Offset
		18615 to 19185	18615 (1851.50MHz), 19185 (1908.50MHz)	3MHz	QPSK	1 RB / 0 RB Offset
		18625 to 19175	18625 (1852.50MHz), 19175 (1907.50MHz)	5MHz	QPSK	1 RB / 0 RB Offset
		18650 to 19150	18650 (1855.00MHz), 19150 (1905.00MHz)	10MHz	QPSK	1 RB / 0 RB Offset
		18675 to 19125	18675 (1857.50MHz), 19125 (1902.50MHz)	15MHz	QPSK	1 RB / 0 RB Offset
		18700 to 19100	18700 (1860.00MHz), 19100 (1900.00MHz)	20MHz	QPSK	1 RB / 0 RB Offset
-	Occupied Bandwidth	18607 to 19193	18607 (1850.70MHz), 18900 (1880.00MHz), 19193 (1909.30MHz)	1.4MHz	QPSK / 16QAM / 64QAM	6 RB / 0RB Offset
		18615 to 19185	18615 (1851.50MHz), 18900 (1880.00MHz), 19185 (1908.50MHz)	3MHz	QPSK / 16QAM / 64QAM	15 RB / 0RB Offset
		18625 to 19175	18625 (1852.50MHz), 18900 (1880.00MHz), 19175 (1907.50MHz)	5MHz	QPSK / 16QAM / 64QAM	25RB / 0RB Offset
		18650 to 19150	18650 (1855.00MHz), 18900 (1880.00MHz), 19150 (1905.00MHz)	10MHz	QPSK / 16QAM / 64QAM	50RB / 0RB Offset
		18675 to 19125	18675 (1857.50MHz), 18900 (1880.00MHz), 19125 (1902.50MHz)	15MHz	QPSK / 16QAM / 64QAM	75 RB / 0 RB Offset
		18700 to 19100	18700 (1860.00MHz), 18900 (1880.00MHz), 19100 (1900.00MHz)	20MHz	QPSK / 16QAM / 64QAM	100 RB / 0 RB Offset

EUT Configure Mode	Test item	Available channel	Tested Channel	Channel Bandwidth	Modulation	Mode
-	Band Edge	18607 to 19193	18607 (1850.70MHz), 19193 (1909.30MHz)	1.4MHz	QPSK	1 RB / 0 RB Offset 1 RB / 5 RB Offset 6 RB / 0 RB Offset
		18615 to 19185	18615 (1851.50MHz), 19185 (1908.50MHz)	3MHz	QPSK	1 RB / 0 RB Offset 1 RB / 14 RB Offset 15 RB / 0 RB Offset
		18625 to 19175	18625 (1852.50MHz), 19175 (1907.50MHz)	5MHz	QPSK	1 RB / 0 RB Offset 1 RB / 24 RB Offset 25 RB / 0 RB Offset
		18650 to 19150	18650 (1855.00MHz), 19150 (1905.00MHz)	10MHz	QPSK	1 RB / 0 RB Offset 1 RB / 49 RB Offset 50 RB / 0 RB Offset
		18675 to 19125	18675 (1857.50MHz), 19125 (1902.50MHz)	15MHz	QPSK	1 RB / 0 RB Offset 1 RB / 74 RB Offset 75 RB / 0 RB Offset
		18700 to 19100	18700 (1860.00MHz), 19100 (1900.00MHz)	20MHz	QPSK	1 RB / 0 RB Offset 1 RB / 99 RB Offset 100 RB / 0 RB Offset
-	Peak to Average Ratio	18607 to 19193	18607 (1850.70MHz), 18900 (1880.00MHz), 19193 (1909.30MHz)	1.4MHz	QPSK / 16QAM / 64QAM	1 RB / 0 RB Offset
		18615 to 19185	18615 (1851.50MHz), 18900 (1880.00MHz), 19185 (1908.50MHz)	3MHz	QPSK / 16QAM / 64QAM	1 RB / 0 RB Offset
		18625 to 19175	18625 (1852.50MHz), 18900 (1880.00MHz), 19175 (1907.50MHz)	5MHz	QPSK / 16QAM / 64QAM	1 RB / 0 RB Offset
		18650 to 19150	18650 (1855.00MHz), 18900 (1880.00MHz), 19150 (1905.00MHz)	10MHz	QPSK / 16QAM / 64QAM	1 RB / 0 RB Offset
		18675 to 19125	18675 (1857.50MHz), 18900 (1880.00MHz), 19125 (1902.50MHz)	15MHz	QPSK / 16QAM / 64QAM	1 RB / 0 RB Offset
		18700 to 19100	18700 (1860.00MHz), 18900 (1880.00MHz), 19100 (1900.00MHz)	20MHz	QPSK / 16QAM / 64QAM	1 RB / 0 RB Offset
-	Conducted Emission	18607 to 19193	18607 (1850.70MHz), 18900 (1880.00MHz), 19193 (1909.30MHz)	1.4MHz	QPSK	1 RB / 0 RB Offset
		18615 to 19185	18615 (1851.50MHz), 18900 (1880.00MHz), 19185 (1908.50MHz)	3MHz	QPSK	1 RB / 0 RB Offset
		18625 to 19175	18625 (1852.50MHz), 18900 (1880.00MHz), 19175 (1907.50MHz)	5MHz	QPSK	1 RB / 0 RB Offset
		18650 to 19150	18650 (1855.00MHz), 18900 (1880.00MHz), 19150 (1905.00MHz)	10MHz	QPSK	1 RB / 0 RB Offset
		18675 to 19125	18675 (1857.50MHz), 18900 (1880.00MHz), 19125 (1902.50MHz)	15MHz	QPSK	1 RB / 0 RB Offset
		18700 to 19100	18700 (1860.00MHz), 18900 (1880.00MHz), 19100 (1900.00MHz)	20MHz	QPSK	1 RB / 0 RB Offset

EUT Configure Mode	Test item	Available channel	Tested Channel	Channel Bandwidth	Modulation	Mode
-	Radiated Emission Below 1GHz	18607 to 19193	18607 (1850.70MHz)	1.4MHz	QPSK	1 RB / 0 RB Offset
-	Radiated Emission Above 1GHz	18607 to 19193	18607 (1850.70MHz), 18900 (1880.00MHz), 19193 (1909.30MHz)	1.4MHz	QPSK	1 RB / 0 RB Offset
		18625 to 19175	18625 (1852.50MHz), 18900 (1880.00MHz), 19175 (1907.50MHz)	5MHz	QPSK	1 RB / 0 RB Offset
		18700 to 19100	18700 (1860.00MHz), 18900 (1880.00MHz), 19100 (1900.00MHz)	20MHz	QPSK	1 RB / 0 RB Offset

**Note:**

1. For radiated emission below 1GHz, low, mid and high channels were pre-tested in chamber with 1.4MHz mode. Low channel was found to be the worst case and therefore had been chosen for all final tests.
2. For radiated emission above 1GHz, according to 3GPP 36.521 Section 6.6.3.1.4, choose the lowest, 5MHz & highest channel bandwidth for final test.
3. The conducted output power for QPSK, 16QAM and 64QAM, measured value of QPSK is higher than 16QAM and 64QAM mode. Therefore, only Modulation characteristics, occupied bandwidth and Peak to average ratio items had been tested under QPSK, 16QAM and 64QAM modes, the other test items were performed under QPSK mode only.

**Test Condition:**

Test Item	Environmental Conditions	Input Power (system)	Tested By
EIRP	25deg. C, 70%RH	120Vac, 60Hz	Han Wu
Modulation Characteristics	24deg. C, 64%RH	120Vac, 60Hz	James Yang
Frequency Stability	24deg. C, 64%RH	120Vac, 60Hz	James Yang
Occupied Bandwidth	24deg. C, 64%RH	120Vac, 60Hz	James Yang
Band Edge	24deg. C, 64%RH	120Vac, 60Hz	James Yang
Peak To Average Ratio	24deg. C, 64%RH	120Vac, 60Hz	James Yang
Conducted Emission	24deg. C, 64%RH	120Vac, 60Hz	James Yang
Radiated Emission	25deg. C, 70%RH	120Vac, 60Hz	Noah Chang

### **3.4 EUT Operating Conditions**

The EUT makes a call to the communication simulator. The communication simulator station system controlled a EUT to export maximum output power under transmission mode and specific channel frequency

### **3.5 General Description of Applied Standards**

The EUT is a RF Product. According to the specifications of the manufacturer, it must comply with the requirements of the following standards:

**FCC 47 CFR Part 2**

**FCC 47 CFR Part 24**

**KDB 971168 D01 Power Meas License Digital Systems v03r01**

**ANSI/TIA/EIA-603-E 2016**

**ANSI 63.26-2015**

**ANSI 63.2 -1996**

All test items have been performed and recorded as per the above standards.



## 4 Test Types and Results

### 4.1 Output Power Measurement

#### 4.1.1 Limits of Output Power Measurement

Mobile / Portable station are limited to 2 watts e.i.r.p.

#### 4.1.2 Test Procedures

##### EIRP / ERP Measurement:

- a. All measurements were done at low, middle and high operational frequency range. RBW and VBW is 1MHz for GSM/GPRS/EDGE, 5MHz for WCDMA mode and 10MHz for LTE mode.
- b. Substitution method is used for E.I.R.P measurement. In the semi-anechoic chamber, EUT placed on the 0.8m(below or equal 1GHz) and/or 1.5m(above 1GHz) height of Turn Table, rotated the table around 360 degrees to search the maximum radiation power and receiver antenna shall be rotated vertical and horizontal polarization and moved height from 1m to 4m to find the maximum polar radiated power. The "Read Value" is the spectrum reading the maximum power value.
- c. The substitution horn antenna is substituted for EUT at the same position and signals generator export the CW signal to the substitution antenna via a TX cable. Rotated the Turn Table and moved receiving antenna to find the maximum radiation power. Adjust output power level of S.G to get a Value of spectrum reading equal to "Read Value" of step b. Record the power level of S.G
- d. EIRP = Output power level of S.G – TX cable loss + Antenna gain of substitution horn. E.R.P power can be calculated form E.I.R.P power by subtracting the gain of dipole, E.R.P power = E.I.R.P power - 2.15dBi.

Where:

$$ERP/EIRP = P_{Meas} + G_T - L_C$$

$P_{Meas}$  : Measure transmitter output power.

$G_T$  : Gain of the transmitting antenna.

$L_C$  : signal attenuation in the connecting cable between the transmitter and antenna.

##### Conducted Power Measurement:

The EUT was set up for the maximum power with GSM, WCDMA and LTE link data modulation and link up with simulator. Set the EUT to transmit under low, middle and high channel and record the power level shown on simulator.

### 4.1.3 Test Setup

EIRP / ERP Measurement:

For radiated emission 30MHz to 1GHz

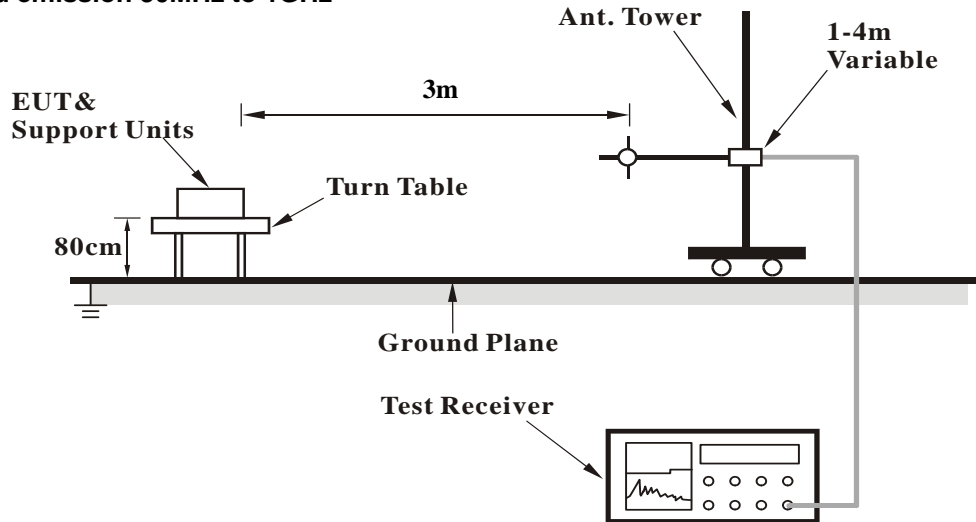

For radiated emission above 1GHz

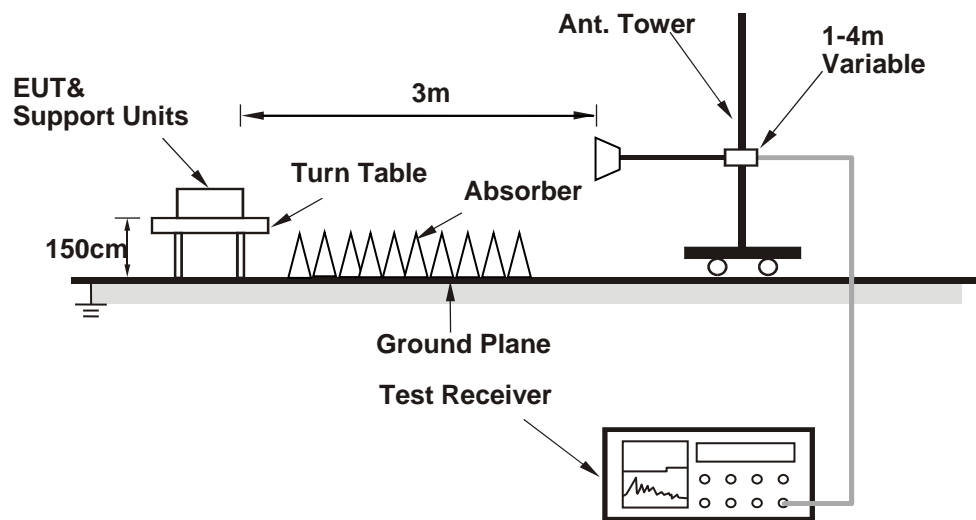

For the actual test configuration, please refer to the attached file (Test Setup Photo).

Conducted Power Measurement:



For the actual test configuration, please refer to the attached file (Test Setup Photo).

#### 4.1.4 Test Results

##### Conducted Output Power (dBm)

Band	GSM1900			Max. Tune-up Power
Channel	512	661	810	
Frequency	1850.2	1880	1909.8	
GSM	29.71	29.79	29.99	30.00
GPRS 1Tx Slot	29.70	29.77	29.98	30.00
GPRS 2Tx Slot	29.43	29.50	29.78	30.00
EDGE 1Tx Slot (MCS9)	26.26	26.34	26.62	27.00
EDGE 2Tx Slot (MCS9)	25.82	25.96	26.24	26.50

Band	WCDMA II			Max. Tune-up Power
TX Channel	9262	9400	9538	
Rx Channel	9662	9800	9938	
Frequency	1852.4	1880	1907.6	
RMC 12.2K	22.07	22.98	22.56	23.0
HSDPA Subtest-1	21.08	21.99	21.57	23.0
HSDPA Subtest-2	21.04	21.95	21.53	23.0
HSDPA Subtest-3	20.56	21.47	21.05	22.5
HSDPA Subtest-4	20.55	21.46	21.04	22.5
DC-HSDPA Subtest-1	21.02	22.08	21.84	23.0
DC-HSDPA Subtest-2	21.05	22.06	21.81	23.0
DC-HSDPA Subtest-3	20.52	21.60	21.35	22.5
DC-HSDPA Subtest-4	20.51	21.58	21.34	22.5
HSUPA Subtest-1	21.10	22.01	21.59	23.0
HSUPA Subtest-2	19.07	19.98	19.56	21.0
HSUPA Subtest-3	20.05	20.96	20.54	22.0
HSUPA Subtest-4	19.06	19.97	19.55	21.0
HSUPA Subtest-5	21.10	22.01	21.59	23.0

LTE Band 2								
BW	MCS Index	RB Size	RB Offset	Low	Mid	High	3GPP MPR (dB)	Max. Tune-up (dBm)
		Channel		18607	18900	19193		
		Frequency (MHz)		1850.7	1880	1909.3		
1.4M	QPSK	1	0	22.00	22.13	21.87	0	23
		1	2	22.08	21.85	21.83	0	23
		1	5	22.03	21.97	21.84	0	23
		3	0	22.14	22.06	21.99	0	23
		3	1	22.15	22.09	22.00	0	23
		3	3	22.10	22.02	21.96	0	23
	16QAM	6	0	21.11	21.13	20.93	1	22
		1	0	20.94	20.94	20.95	1	22
		1	2	20.81	20.83	20.66	1	22
		1	5	21.02	21.03	20.81	1	22
		3	0	20.98	21.08	20.95	1	22
		3	1	21.23	21.15	20.90	1	22
	64QAM	3	3	21.06	21.12	20.96	1	22
		6	0	20.03	20.01	19.87	2	21
		1	0	19.88	19.94	19.94	2	21
		1	2	19.95	19.93	19.81	2	21
		1	5	20.01	19.95	19.90	2	21
		3	0	20.15	20.05	19.93	2	21
		3	1	20.04	20.06	19.93	2	21
	3	3	20.19	20.02	19.91	2	21	
	6	0	19.08	19.06	18.87	3	20	

LTE Band 2								
BW	MCS Index	RB Size	RB Offset	Low	Mid	High	3GPP MPR (dB)	Max. Tune-up (dBm)
		Channel		18615	18900	19185		
		Frequency (MHz)		1851.5	1880	1908.5		
3M	QPSK	1	0	22.01	22.05	21.90	0	23
		1	7	21.89	22.02	21.86	0	23
		1	14	22.00	22.04	21.84	0	23
		8	0	21.15	21.11	21.03	1	22
		8	3	21.13	21.10	21.00	1	22
		8	7	21.09	21.25	20.96	1	22
		15	0	21.14	21.06	20.84	1	22
	16QAM	1	0	21.05	21.01	20.88	1	22
		1	7	20.92	20.90	20.75	1	22
		1	14	20.95	21.05	20.73	1	22
		8	0	19.99	20.11	19.86	2	21
		8	3	20.01	20.03	20.00	2	21
		8	7	20.19	20.17	19.96	2	21
		15	0	20.05	20.11	19.91	2	21
	64QAM	1	0	20.08	20.08	19.82	2	21
		1	7	19.88	19.95	19.77	2	21
		1	14	19.93	19.94	19.73	2	21
		8	0	19.11	19.03	18.93	3	20
		8	3	19.08	19.13	18.88	3	20
		8	7	19.21	19.15	18.81	3	20
		15	0	19.08	19.00	18.91	3	20

LTE Band 2								
BW	MCS Index	RB Size	RB Offset	Low	Mid	High	3GPP MPR (dB)	Max. Tune-up (dBm)
		Channel		18625	18900	19175		
		Frequency (MHz)		1852.5	1880	1907.5		
5M	QPSK	1	0	22.20	22.15	21.88	0	23
		1	12	22.04	21.99	21.82	0	23
		1	24	22.05	21.91	21.73	0	23
		12	0	21.26	21.13	20.94	1	22
		12	6	21.19	21.06	20.94	1	22
		12	13	21.12	21.12	21.03	1	22
		25	0	21.12	21.11	20.93	1	22
	16QAM	1	0	21.08	21.01	20.93	1	22
		1	12	20.98	20.89	20.74	1	22
		1	24	20.87	20.95	20.82	1	22
		12	0	20.14	20.14	19.90	2	21
		12	6	19.97	20.14	19.79	2	21
		12	13	20.05	20.14	19.97	2	21
		25	0	20.02	20.07	20.04	2	21
	64QAM	1	0	19.98	20.01	19.93	2	21
		1	12	19.90	19.86	19.65	2	21
		1	24	20.11	20.04	19.77	2	21
		12	0	19.04	19.12	18.79	3	20
		12	6	19.08	19.16	18.95	3	20
		12	13	19.10	19.02	18.98	3	20
		25	0	19.07	19.07	18.91	3	20

LTE Band 2								
BW	MCS Index	RB Size	RB Offset	Low	Mid	High	3GPP MPR (dB)	Max. Tune-up (dBm)
		Channel		18650	18900	19150		
		Frequency (MHz)		1855	1880	1905		
10M	QPSK	1	0	22.08	22.09	21.84	0	23
		1	24	21.98	22.01	21.74	0	23
		1	49	22.08	21.93	21.90	0	23
		25	0	21.22	21.07	20.85	1	22
		25	12	21.19	21.16	20.97	1	22
		25	25	21.15	21.17	20.95	1	22
		50	0	21.16	21.11	20.94	1	22
	16QAM	1	0	20.99	21.11	20.80	1	22
		1	24	20.87	20.96	20.65	1	22
		1	49	21.00	21.03	20.74	1	22
		25	0	20.13	19.99	19.87	2	21
		25	12	20.11	20.13	19.91	2	21
		25	25	20.14	20.05	20.02	2	21
		50	0	20.10	19.96	19.86	2	21
	64QAM	1	0	19.97	20.08	19.80	2	21
		1	24	20.00	19.99	19.67	2	21
		1	49	20.05	19.91	19.78	2	21
		25	0	19.15	18.95	18.88	3	20
		25	12	19.08	19.09	18.88	3	20
		25	25	19.19	19.22	18.86	3	20
		50	0	19.17	18.98	18.91	3	20

LTE Band 2								
BW	MCS Index	RB Size	RB Offset	Low	Mid	High	3GPP MPR (dB)	Max. Tune-up (dBm)
		Channel		18675	18900	19125		
		Frequency (MHz)		1857.5	1880	1902.5		
15M	QPSK	1	0	22.13	22.17	21.97	0	23
		1	37	22.08	22.03	21.83	0	23
		1	74	22.08	22.09	21.98	0	23
		36	0	21.20	21.20	21.08	1	22
		36	19	21.20	21.26	21.09	1	22
		36	39	21.27	21.27	21.09	1	22
		75	0	21.17	21.15	21.01	1	22
	16QAM	1	0	21.10	21.00	20.92	1	22
		1	37	21.06	20.94	20.81	1	22
		1	74	21.07	21.05	20.78	1	22
		36	0	20.20	20.11	19.97	2	21
		36	19	20.14	20.14	20.03	2	21
		36	39	20.21	20.17	19.98	2	21
		75	0	20.21	20.15	19.96	2	21
	64QAM	1	0	20.08	20.04	19.99	2	21
		1	37	20.00	19.99	19.80	2	21
		1	74	20.09	20.07	19.92	2	21
		36	0	19.21	19.14	19.04	3	20
		36	19	19.18	19.21	19.01	3	20
		36	39	19.17	19.20	19.08	3	20
		75	0	19.23	19.10	18.90	3	20



LTE Band 2								
BW	MCS Index	RB Size	RB Offset	Low	Mid	High	3GPP MPR (dB)	Max. Tune-up (dBm)
		Channel		18700	18900	19100		
		Frequency (MHz)		1860	1880	1900		
20M	QPSK	1	0	22.21	22.18	22.02	0	23
		1	50	22.11	22.08	21.92	0	23
		1	99	22.17	22.14	21.98	0	23
		50	0	21.27	21.24	21.08	1	22
		50	25	21.29	21.26	21.10	1	22
		50	50	21.31	21.28	21.12	1	22
		100	0	21.27	21.24	21.08	1	22
	16QAM	1	0	21.15	21.12	21.01	1	22
		1	50	21.05	21.08	20.86	1	22
		1	99	21.12	21.04	20.93	1	22
		50	0	20.19	20.14	19.99	2	21
		50	25	20.24	20.23	20.07	2	21
		50	50	20.31	20.27	20.02	2	21
		100	0	20.25	20.22	19.98	2	21
	64QAM	1	0	20.16	20.12	19.94	2	21
		1	50	20.06	19.99	19.84	2	21
		1	99	20.09	20.11	19.92	2	21
		50	0	19.17	19.17	18.98	3	20
		50	25	19.23	19.22	19.08	3	20
		50	50	19.24	19.28	19.02	3	20
		100	0	19.18	19.21	18.99	3	20

### EIRP Power

GSM Mode

Mode		TX channel 512					
Antenna Polarity & Test Distance: Horizontal at 3 M							
No.	Freq. (MHz)	Reading (dBm)	S.G Power Value (dBm)	Correction Factor (dB)	EIRP (dBm)	Limit (dBm)	Margin (dB)
1	1850.20	-18.70	21.50	0.10	21.60	33.00	-11.40
Antenna Polarity & Test Distance: Vertical at 3 M							
No.	Freq. (MHz)	Reading (dBm)	S.G Power Value (dBm)	Correction Factor (dB)	EIRP (dBm)	Limit (dBm)	Margin (dB)
1	1850.20	-20.90	19.50	0.10	19.60	33.00	-13.40

Mode		TX channel 661					
Antenna Polarity & Test Distance: Horizontal at 3 M							
No.	Freq. (MHz)	Reading (dBm)	S.G Power Value (dBm)	Correction Factor (dB)	EIRP (dBm)	Limit (dBm)	Margin (dB)
1	1880.00	-18.90	21.60	0.00	21.60	33.00	-11.40
Antenna Polarity & Test Distance: Vertical at 3 M							
No.	Freq. (MHz)	Reading (dBm)	S.G Power Value (dBm)	Correction Factor (dB)	EIRP (dBm)	Limit (dBm)	Margin (dB)
1	1880.00	-21.00	19.60	0.00	19.60	33.00	-13.40

Mode		TX channel 810					
Antenna Polarity & Test Distance: Horizontal at 3 M							
No.	Freq. (MHz)	Reading (dBm)	S.G Power Value (dBm)	Correction Factor (dB)	EIRP (dBm)	Limit (dBm)	Margin (dB)
1	1909.80	-19.10	21.50	-0.10	21.40	33.00	-11.60
Antenna Polarity & Test Distance: Vertical at 3 M							
No.	Freq. (MHz)	Reading (dBm)	S.G Power Value (dBm)	Correction Factor (dB)	EIRP (dBm)	Limit (dBm)	Margin (dB)
1	1909.80	-21.30	19.50	-0.10	19.40	33.00	-13.60

Note: EIRP (dBm) = S.G Power Value (dBm) + Correction Factor (dB).

WCDMA Band 2

Mode		TX channel 9262					
Antenna Polarity & Test Distance: Horizontal at 3 M							
No.	Freq. (MHz)	Reading (dBm)	S.G Power Value (dBm)	Correction Factor (dB)	EIRP (dBm)	Limit (dBm)	Margin (dB)
1	1852.40	-18.10	22.10	0.10	22.20	33.00	-10.80
Antenna Polarity & Test Distance: Vertical at 3 M							
No.	Freq. (MHz)	Reading (dBm)	S.G Power Value (dBm)	Correction Factor (dB)	EIRP (dBm)	Limit (dBm)	Margin (dB)
1	1852.40	-22.50	17.90	0.10	18.00	33.00	-15.00

Mode		TX channel 9400					
Antenna Polarity & Test Distance: Horizontal at 3 M							
No.	Freq. (MHz)	Reading (dBm)	S.G Power Value (dBm)	Correction Factor (dB)	EIRP (dBm)	Limit (dBm)	Margin (dB)
1	1880.00	-17.90	22.60	0.00	22.60	33.00	-10.40
Antenna Polarity & Test Distance: Vertical at 3 M							
No.	Freq. (MHz)	Reading (dBm)	S.G Power Value (dBm)	Correction Factor (dB)	EIRP (dBm)	Limit (dBm)	Margin (dB)
1	1880.00	-22.30	18.30	0.00	18.30	33.00	-14.70

Mode		TX channel 9538					
Antenna Polarity & Test Distance: Horizontal at 3 M							
No.	Freq. (MHz)	Reading (dBm)	S.G Power Value (dBm)	Correction Factor (dB)	EIRP (dBm)	Limit (dBm)	Margin (dB)
1	1907.60	-17.70	23.00	-0.10	22.90	33.00	-10.10
Antenna Polarity & Test Distance: Vertical at 3 M							
No.	Freq. (MHz)	Reading (dBm)	S.G Power Value (dBm)	Correction Factor (dB)	EIRP (dBm)	Limit (dBm)	Margin (dB)
1	1907.60	-22.20	18.60	-0.10	18.50	33.00	-14.50

Note: EIRP (dBm) = S.G Power Value (dBm) + Correction Factor (dB).

**Modulation Type: QPSK**

LTE Band 2, Channel Bandwidth 1.4MHz

Mode		TX channel 18607					
Antenna Polarity & Test Distance: Horizontal at 3 M							
No.	Freq. (MHz)	Reading (dBm)	S.G Power Value (dBm)	Correction Factor (dB)	EIRP (dBm)	Limit (dBm)	Margin (dB)
1	1850.70	-20.50	19.40	1.00	20.40	33.00	-12.60
Antenna Polarity & Test Distance: Vertical at 3 M							
No.	Freq. (MHz)	Reading (dBm)	S.G Power Value (dBm)	Correction Factor (dB)	EIRP (dBm)	Limit (dBm)	Margin (dB)
1	1850.70	-26.70	12.10	1.00	13.10	33.00	-19.90

Mode		TX channel 18900					
Antenna Polarity & Test Distance: Horizontal at 3 M							
No.	Freq. (MHz)	Reading (dBm)	S.G Power Value (dBm)	Correction Factor (dB)	EIRP (dBm)	Limit (dBm)	Margin (dB)
1	1880.00	-20.60	19.50	1.10	20.60	33.00	-12.40
Antenna Polarity & Test Distance: Vertical at 3 M							
No.	Freq. (MHz)	Reading (dBm)	S.G Power Value (dBm)	Correction Factor (dB)	EIRP (dBm)	Limit (dBm)	Margin (dB)
1	1880.00	-26.00	12.50	1.10	13.60	33.00	-19.40

Mode		TX channel 19193					
Antenna Polarity & Test Distance: Horizontal at 3 M							
No.	Freq. (MHz)	Reading (dBm)	S.G Power Value (dBm)	Correction Factor (dB)	EIRP (dBm)	Limit (dBm)	Margin (dB)
1	1909.30	-21.20	19.20	1.10	20.30	33.00	-12.70
Antenna Polarity & Test Distance: Vertical at 3 M							
No.	Freq. (MHz)	Reading (dBm)	S.G Power Value (dBm)	Correction Factor (dB)	EIRP (dBm)	Limit (dBm)	Margin (dB)
1	1909.30	-26.30	12.10	1.10	13.20	33.00	-19.80

Note: EIRP (dBm) = S.G Power Value (dBm) + Correction Factor (dB).

LTE Band 2, Channel Bandwidth 3MHz

Mode		TX channel 18615					
Antenna Polarity & Test Distance: Horizontal at 3 M							
No.	Freq. (MHz)	Reading (dBm)	S.G Power Value (dBm)	Correction Factor (dB)	EIRP (dBm)	Limit (dBm)	Margin (dB)
1	1851.50	-20.90	19.00	1.00	20.00	33.00	-13.00
Antenna Polarity & Test Distance: Vertical at 3 M							
No.	Freq. (MHz)	Reading (dBm)	S.G Power Value (dBm)	Correction Factor (dB)	EIRP (dBm)	Limit (dBm)	Margin (dB)
1	1851.50	-26.10	12.70	1.00	13.70	33.00	-19.30

Mode		TX channel 18900					
Antenna Polarity & Test Distance: Horizontal at 3 M							
No.	Freq. (MHz)	Reading (dBm)	S.G Power Value (dBm)	Correction Factor (dB)	EIRP (dBm)	Limit (dBm)	Margin (dB)
1	1880.00	-20.50	19.60	1.10	20.70	33.00	-12.30
Antenna Polarity & Test Distance: Vertical at 3 M							
No.	Freq. (MHz)	Reading (dBm)	S.G Power Value (dBm)	Correction Factor (dB)	EIRP (dBm)	Limit (dBm)	Margin (dB)
1	1880.00	-26.20	12.30	1.10	13.40	33.00	-19.60

Mode		TX channel 19185					
Antenna Polarity & Test Distance: Horizontal at 3 M							
No.	Freq. (MHz)	Reading (dBm)	S.G Power Value (dBm)	Correction Factor (dB)	EIRP (dBm)	Limit (dBm)	Margin (dB)
1	1908.50	-21.40	19.00	1.10	20.10	33.00	-12.90
Antenna Polarity & Test Distance: Vertical at 3 M							
No.	Freq. (MHz)	Reading (dBm)	S.G Power Value (dBm)	Correction Factor (dB)	EIRP (dBm)	Limit (dBm)	Margin (dB)
1	1908.50	-26.00	12.40	1.10	13.50	33.00	-19.50

Note: EIRP (dBm) = S.G Power Value (dBm) + Correction Factor (dB).

LTE Band 2, Channel Bandwidth 5MHz

Mode		TX channel 18625					
Antenna Polarity & Test Distance: Horizontal at 3 M							
No.	Freq. (MHz)	Reading (dBm)	S.G Power Value (dBm)	Correction Factor (dB)	EIRP (dBm)	Limit (dBm)	Margin (dB)
1	1852.50	-20.00	19.90	1.00	20.90	33.00	-12.10
Antenna Polarity & Test Distance: Vertical at 3 M							
No.	Freq. (MHz)	Reading (dBm)	S.G Power Value (dBm)	Correction Factor (dB)	EIRP (dBm)	Limit (dBm)	Margin (dB)
1	1852.50	-26.60	12.20	1.00	13.20	33.00	-19.80

Mode		TX channel 18900					
Antenna Polarity & Test Distance: Horizontal at 3 M							
No.	Freq. (MHz)	Reading (dBm)	S.G Power Value (dBm)	Correction Factor (dB)	EIRP (dBm)	Limit (dBm)	Margin (dB)
1	1880.00	-20.40	19.70	1.10	20.80	33.00	-12.20
Antenna Polarity & Test Distance: Vertical at 3 M							
No.	Freq. (MHz)	Reading (dBm)	S.G Power Value (dBm)	Correction Factor (dB)	EIRP (dBm)	Limit (dBm)	Margin (dB)
1	1880.00	-26.00	12.50	1.10	13.60	33.00	-19.40

Mode		TX channel 19175					
Antenna Polarity & Test Distance: Horizontal at 3 M							
No.	Freq. (MHz)	Reading (dBm)	S.G Power Value (dBm)	Correction Factor (dB)	EIRP (dBm)	Limit (dBm)	Margin (dB)
1	1907.50	-21.50	18.90	1.10	20.00	33.00	-13.00
Antenna Polarity & Test Distance: Vertical at 3 M							
No.	Freq. (MHz)	Reading (dBm)	S.G Power Value (dBm)	Correction Factor (dB)	EIRP (dBm)	Limit (dBm)	Margin (dB)
1	1907.50	-26.10	12.30	1.10	13.40	33.00	-19.60

Note: EIRP (dBm) = S.G Power Value (dBm) + Correction Factor (dB).

LTE Band 2, Channel Bandwidth 10MHz

Mode		TX channel 18650					
Antenna Polarity & Test Distance: Horizontal at 3 M							
No.	Freq. (MHz)	Reading (dBm)	S.G Power Value (dBm)	Correction Factor (dB)	EIRP (dBm)	Limit (dBm)	Margin (dB)
1	1855.00	-20.80	19.20	1.00	20.20	33.00	-12.80
Antenna Polarity & Test Distance: Vertical at 3 M							
No.	Freq. (MHz)	Reading (dBm)	S.G Power Value (dBm)	Correction Factor (dB)	EIRP (dBm)	Limit (dBm)	Margin (dB)
1	1855.00	-26.50	12.30	1.00	13.30	33.00	-19.70

Mode		TX channel 18900					
Antenna Polarity & Test Distance: Horizontal at 3 M							
No.	Freq. (MHz)	Reading (dBm)	S.G Power Value (dBm)	Correction Factor (dB)	EIRP (dBm)	Limit (dBm)	Margin (dB)
1	1880.00	-21.10	19.00	1.10	20.10	33.00	-12.90
Antenna Polarity & Test Distance: Vertical at 3 M							
No.	Freq. (MHz)	Reading (dBm)	S.G Power Value (dBm)	Correction Factor (dB)	EIRP (dBm)	Limit (dBm)	Margin (dB)
1	1880.00	-25.90	12.60	1.10	13.70	33.00	-19.30

Mode		TX channel 19150					
Antenna Polarity & Test Distance: Horizontal at 3 M							
No.	Freq. (MHz)	Reading (dBm)	S.G Power Value (dBm)	Correction Factor (dB)	EIRP (dBm)	Limit (dBm)	Margin (dB)
1	1905.00	-21.60	18.80	1.10	19.90	33.00	-13.10
Antenna Polarity & Test Distance: Vertical at 3 M							
No.	Freq. (MHz)	Reading (dBm)	S.G Power Value (dBm)	Correction Factor (dB)	EIRP (dBm)	Limit (dBm)	Margin (dB)
1	1905.00	-26.10	12.30	1.10	13.40	33.00	-19.60

Note: EIRP (dBm) = S.G Power Value (dBm) + Correction Factor (dB).

LTE Band 2, Channel Bandwidth 15MHz

Mode		TX channel 18675					
Antenna Polarity & Test Distance: Horizontal at 3 M							
No.	Freq. (MHz)	Reading (dBm)	S.G Power Value (dBm)	Correction Factor (dB)	EIRP (dBm)	Limit (dBm)	Margin (dB)
1	1857.50	-20.40	19.50	1.10	20.60	33.00	-12.40
Antenna Polarity & Test Distance: Vertical at 3 M							
No.	Freq. (MHz)	Reading (dBm)	S.G Power Value (dBm)	Correction Factor (dB)	EIRP (dBm)	Limit (dBm)	Margin (dB)
1	1857.50	-25.90	12.80	1.10	13.90	33.00	-19.10

Mode		TX channel 18900					
Antenna Polarity & Test Distance: Horizontal at 3 M							
No.	Freq. (MHz)	Reading (dBm)	S.G Power Value (dBm)	Correction Factor (dB)	EIRP (dBm)	Limit (dBm)	Margin (dB)
1	1880.00	-20.90	19.20	1.10	20.30	33.00	-12.70
Antenna Polarity & Test Distance: Vertical at 3 M							
No.	Freq. (MHz)	Reading (dBm)	S.G Power Value (dBm)	Correction Factor (dB)	EIRP (dBm)	Limit (dBm)	Margin (dB)
1	1880.00	-25.80	12.70	1.10	13.80	33.00	-19.20

Mode		TX channel 19125					
Antenna Polarity & Test Distance: Horizontal at 3 M							
No.	Freq. (MHz)	Reading (dBm)	S.G Power Value (dBm)	Correction Factor (dB)	EIRP (dBm)	Limit (dBm)	Margin (dB)
1	1902.50	-21.00	19.40	1.10	20.50	33.00	-12.50
Antenna Polarity & Test Distance: Vertical at 3 M							
No.	Freq. (MHz)	Reading (dBm)	S.G Power Value (dBm)	Correction Factor (dB)	EIRP (dBm)	Limit (dBm)	Margin (dB)
1	1902.50	-26.30	12.10	1.10	13.20	33.00	-19.80

Note: EIRP (dBm) = S.G Power Value (dBm) + Correction Factor (dB).



LTE Band 2, Channel Bandwidth 20MHz

Mode		TX channel 18700					
Antenna Polarity & Test Distance: Horizontal at 3 M							
No.	Freq. (MHz)	Reading (dBm)	S.G Power Value (dBm)	Correction Factor (dB)	EIRP (dBm)	Limit (dBm)	Margin (dB)
1	1860.00	-20.80	19.10	1.10	20.20	33.00	-12.80
Antenna Polarity & Test Distance: Vertical at 3 M							
No.	Freq. (MHz)	Reading (dBm)	S.G Power Value (dBm)	Correction Factor (dB)	EIRP (dBm)	Limit (dBm)	Margin (dB)
1	1860.00	-26.30	12.30	1.10	13.40	33.00	-19.60

Mode		TX channel 18900					
Antenna Polarity & Test Distance: Horizontal at 3 M							
No.	Freq. (MHz)	Reading (dBm)	S.G Power Value (dBm)	Correction Factor (dB)	EIRP (dBm)	Limit (dBm)	Margin (dB)
1	1880.00	-20.70	19.40	1.10	20.50	33.00	-12.50
Antenna Polarity & Test Distance: Vertical at 3 M							
No.	Freq. (MHz)	Reading (dBm)	S.G Power Value (dBm)	Correction Factor (dB)	EIRP (dBm)	Limit (dBm)	Margin (dB)
1	1880.00	-26.10	12.40	1.10	13.50	33.00	-19.50

Mode		TX channel 19100					
Antenna Polarity & Test Distance: Horizontal at 3 M							
No.	Freq. (MHz)	Reading (dBm)	S.G Power Value (dBm)	Correction Factor (dB)	EIRP (dBm)	Limit (dBm)	Margin (dB)
1	1900.00	-20.80	19.60	1.10	20.70	33.00	-12.30
Antenna Polarity & Test Distance: Vertical at 3 M							
No.	Freq. (MHz)	Reading (dBm)	S.G Power Value (dBm)	Correction Factor (dB)	EIRP (dBm)	Limit (dBm)	Margin (dB)
1	1900.00	-26.20	12.10	1.10	13.20	33.00	-19.80

Note: EIRP (dBm) = S.G Power Value (dBm) + Correction Factor (dB).

**Modulation Type: 16QAM**

LTE Band 2, Channel Bandwidth 1.4MHz

Mode		TX channel 18607					
Antenna Polarity & Test Distance: Horizontal at 3 M							
No.	Freq. (MHz)	Reading (dBm)	S.G Power Value (dBm)	Correction Factor (dB)	EIRP (dBm)	Limit (dBm)	Margin (dB)
1	1850.70	-21.20	18.70	1.00	19.70	33.00	-13.30
Antenna Polarity & Test Distance: Vertical at 3 M							
No.	Freq. (MHz)	Reading (dBm)	S.G Power Value (dBm)	Correction Factor (dB)	EIRP (dBm)	Limit (dBm)	Margin (dB)
1	1850.70	-27.30	11.50	1.00	12.50	33.00	-20.50

Mode		TX channel 18900					
Antenna Polarity & Test Distance: Horizontal at 3 M							
No.	Freq. (MHz)	Reading (dBm)	S.G Power Value (dBm)	Correction Factor (dB)	EIRP (dBm)	Limit (dBm)	Margin (dB)
1	1880.00	-22.90	17.20	1.10	18.30	33.00	-14.70
Antenna Polarity & Test Distance: Vertical at 3 M							
No.	Freq. (MHz)	Reading (dBm)	S.G Power Value (dBm)	Correction Factor (dB)	EIRP (dBm)	Limit (dBm)	Margin (dB)
1	1880.00	-26.80	11.70	1.10	12.80	33.00	-20.20

Mode		TX channel 19193					
Antenna Polarity & Test Distance: Horizontal at 3 M							
No.	Freq. (MHz)	Reading (dBm)	S.G Power Value (dBm)	Correction Factor (dB)	EIRP (dBm)	Limit (dBm)	Margin (dB)
1	1909.30	-23.80	16.60	1.10	17.70	33.00	-15.30
Antenna Polarity & Test Distance: Vertical at 3 M							
No.	Freq. (MHz)	Reading (dBm)	S.G Power Value (dBm)	Correction Factor (dB)	EIRP (dBm)	Limit (dBm)	Margin (dB)
1	1909.30	-26.90	11.50	1.10	12.60	33.00	-20.40

Note: EIRP (dBm) = S.G Power Value (dBm) + Correction Factor (dB).

LTE Band 2, Channel Bandwidth 3MHz

Mode		TX channel 18615					
Antenna Polarity & Test Distance: Horizontal at 3 M							
No.	Freq. (MHz)	Reading (dBm)	S.G Power Value (dBm)	Correction Factor (dB)	EIRP (dBm)	Limit (dBm)	Margin (dB)
1	1851.50	-21.80	18.10	1.00	19.10	33.00	-13.90
Antenna Polarity & Test Distance: Vertical at 3 M							
No.	Freq. (MHz)	Reading (dBm)	S.G Power Value (dBm)	Correction Factor (dB)	EIRP (dBm)	Limit (dBm)	Margin (dB)
1	1851.50	-26.80	12.00	1.00	13.00	33.00	-20.00

Mode		TX channel 18900					
Antenna Polarity & Test Distance: Horizontal at 3 M							
No.	Freq. (MHz)	Reading (dBm)	S.G Power Value (dBm)	Correction Factor (dB)	EIRP (dBm)	Limit (dBm)	Margin (dB)
1	1880.00	-21.30	18.80	1.10	19.90	33.00	-13.10
Antenna Polarity & Test Distance: Vertical at 3 M							
No.	Freq. (MHz)	Reading (dBm)	S.G Power Value (dBm)	Correction Factor (dB)	EIRP (dBm)	Limit (dBm)	Margin (dB)
1	1880.00	-27.00	11.50	1.10	12.60	33.00	-20.40

Mode		TX channel 19185					
Antenna Polarity & Test Distance: Horizontal at 3 M							
No.	Freq. (MHz)	Reading (dBm)	S.G Power Value (dBm)	Correction Factor (dB)	EIRP (dBm)	Limit (dBm)	Margin (dB)
1	1908.50	-21.90	18.50	1.10	19.60	33.00	-13.40
Antenna Polarity & Test Distance: Vertical at 3 M							
No.	Freq. (MHz)	Reading (dBm)	S.G Power Value (dBm)	Correction Factor (dB)	EIRP (dBm)	Limit (dBm)	Margin (dB)
1	1908.50	-26.80	11.60	1.10	12.70	33.00	-20.30

Note: EIRP (dBm) = S.G Power Value (dBm) + Correction Factor (dB).

LTE Band 2, Channel Bandwidth 5MHz

Mode		TX channel 18625					
Antenna Polarity & Test Distance: Horizontal at 3 M							
No.	Freq. (MHz)	Reading (dBm)	S.G Power Value (dBm)	Correction Factor (dB)	EIRP (dBm)	Limit (dBm)	Margin (dB)
1	1852.50	-21.00	18.90	1.00	19.90	33.00	-13.10
Antenna Polarity & Test Distance: Vertical at 3 M							
No.	Freq. (MHz)	Reading (dBm)	S.G Power Value (dBm)	Correction Factor (dB)	EIRP (dBm)	Limit (dBm)	Margin (dB)
1	1852.50	-27.30	11.50	1.00	12.50	33.00	-20.50

Mode		TX channel 18900					
Antenna Polarity & Test Distance: Horizontal at 3 M							
No.	Freq. (MHz)	Reading (dBm)	S.G Power Value (dBm)	Correction Factor (dB)	EIRP (dBm)	Limit (dBm)	Margin (dB)
1	1880.00	-21.10	19.00	1.10	20.10	33.00	-12.90
Antenna Polarity & Test Distance: Vertical at 3 M							
No.	Freq. (MHz)	Reading (dBm)	S.G Power Value (dBm)	Correction Factor (dB)	EIRP (dBm)	Limit (dBm)	Margin (dB)
1	1880.00	-26.90	11.60	1.10	12.70	33.00	-20.30

Mode		TX channel 19175					
Antenna Polarity & Test Distance: Horizontal at 3 M							
No.	Freq. (MHz)	Reading (dBm)	S.G Power Value (dBm)	Correction Factor (dB)	EIRP (dBm)	Limit (dBm)	Margin (dB)
1	1907.50	-24.40	16.00	1.10	17.10	33.00	-15.90
Antenna Polarity & Test Distance: Vertical at 3 M							
No.	Freq. (MHz)	Reading (dBm)	S.G Power Value (dBm)	Correction Factor (dB)	EIRP (dBm)	Limit (dBm)	Margin (dB)
1	1907.50	-27.00	11.40	1.10	12.50	33.00	-20.50

Note: EIRP (dBm) = S.G Power Value (dBm) + Correction Factor (dB).

LTE Band 2, Channel Bandwidth 10MHz

Mode		TX channel 18650					
Antenna Polarity & Test Distance: Horizontal at 3 M							
No.	Freq. (MHz)	Reading (dBm)	S.G Power Value (dBm)	Correction Factor (dB)	EIRP (dBm)	Limit (dBm)	Margin (dB)
1	1855.00	-21.60	18.40	1.00	19.40	33.00	-13.60
Antenna Polarity & Test Distance: Vertical at 3 M							
No.	Freq. (MHz)	Reading (dBm)	S.G Power Value (dBm)	Correction Factor (dB)	EIRP (dBm)	Limit (dBm)	Margin (dB)
1	1855.00	-27.20	11.60	1.00	12.60	33.00	-20.40

Mode		TX channel 18900					
Antenna Polarity & Test Distance: Horizontal at 3 M							
No.	Freq. (MHz)	Reading (dBm)	S.G Power Value (dBm)	Correction Factor (dB)	EIRP (dBm)	Limit (dBm)	Margin (dB)
1	1880.00	-21.70	18.40	1.10	19.50	33.00	-13.50
Antenna Polarity & Test Distance: Vertical at 3 M							
No.	Freq. (MHz)	Reading (dBm)	S.G Power Value (dBm)	Correction Factor (dB)	EIRP (dBm)	Limit (dBm)	Margin (dB)
1	1880.00	-26.70	11.80	1.10	12.90	33.00	-20.10

Mode		TX channel 19150					
Antenna Polarity & Test Distance: Horizontal at 3 M							
No.	Freq. (MHz)	Reading (dBm)	S.G Power Value (dBm)	Correction Factor (dB)	EIRP (dBm)	Limit (dBm)	Margin (dB)
1	1905.00	-21.90	18.50	1.10	19.60	33.00	-13.40
Antenna Polarity & Test Distance: Vertical at 3 M							
No.	Freq. (MHz)	Reading (dBm)	S.G Power Value (dBm)	Correction Factor (dB)	EIRP (dBm)	Limit (dBm)	Margin (dB)
1	1905.00	-27.00	11.40	1.10	12.50	33.00	-20.50

Note: EIRP (dBm) = S.G Power Value (dBm) + Correction Factor (dB).

LTE Band 2, Channel Bandwidth 15MHz

Mode		TX channel 18675					
Antenna Polarity & Test Distance: Horizontal at 3 M							
No.	Freq. (MHz)	Reading (dBm)	S.G Power Value (dBm)	Correction Factor (dB)	EIRP (dBm)	Limit (dBm)	Margin (dB)
1	1857.50	-20.20	19.70	1.10	20.80	33.00	-12.20
Antenna Polarity & Test Distance: Vertical at 3 M							
No.	Freq. (MHz)	Reading (dBm)	S.G Power Value (dBm)	Correction Factor (dB)	EIRP (dBm)	Limit (dBm)	Margin (dB)
1	1857.50	-26.70	12.00	1.10	13.10	33.00	-19.90

Mode		TX channel 18900					
Antenna Polarity & Test Distance: Horizontal at 3 M							
No.	Freq. (MHz)	Reading (dBm)	S.G Power Value (dBm)	Correction Factor (dB)	EIRP (dBm)	Limit (dBm)	Margin (dB)
1	1880.00	-21.60	18.50	1.10	19.60	33.00	-13.40
Antenna Polarity & Test Distance: Vertical at 3 M							
No.	Freq. (MHz)	Reading (dBm)	S.G Power Value (dBm)	Correction Factor (dB)	EIRP (dBm)	Limit (dBm)	Margin (dB)
1	1880.00	-26.60	11.90	1.10	13.00	33.00	-20.00

Mode		TX channel 19125					
Antenna Polarity & Test Distance: Horizontal at 3 M							
No.	Freq. (MHz)	Reading (dBm)	S.G Power Value (dBm)	Correction Factor (dB)	EIRP (dBm)	Limit (dBm)	Margin (dB)
1	1902.50	-21.70	18.70	1.10	19.80	33.00	-13.20
Antenna Polarity & Test Distance: Vertical at 3 M							
No.	Freq. (MHz)	Reading (dBm)	S.G Power Value (dBm)	Correction Factor (dB)	EIRP (dBm)	Limit (dBm)	Margin (dB)
1	1902.50	-24.90	13.50	1.10	14.60	33.00	-18.40

Note: EIRP (dBm) = S.G Power Value (dBm) + Correction Factor (dB).

LTE Band 2, Channel Bandwidth 20MHz

Mode		TX channel 18700					
Antenna Polarity & Test Distance: Horizontal at 3 M							
No.	Freq. (MHz)	Reading (dBm)	S.G Power Value (dBm)	Correction Factor (dB)	EIRP (dBm)	Limit (dBm)	Margin (dB)
1	1860.00	-21.40	18.50	1.10	19.60	33.00	-13.40
Antenna Polarity & Test Distance: Vertical at 3 M							
No.	Freq. (MHz)	Reading (dBm)	S.G Power Value (dBm)	Correction Factor (dB)	EIRP (dBm)	Limit (dBm)	Margin (dB)
1	1860.00	-26.90	11.70	1.10	12.80	33.00	-20.20

Mode		TX channel 18900					
Antenna Polarity & Test Distance: Horizontal at 3 M							
No.	Freq. (MHz)	Reading (dBm)	S.G Power Value (dBm)	Correction Factor (dB)	EIRP (dBm)	Limit (dBm)	Margin (dB)
1	1880.00	-21.30	18.80	1.10	19.90	33.00	-13.10
Antenna Polarity & Test Distance: Vertical at 3 M							
No.	Freq. (MHz)	Reading (dBm)	S.G Power Value (dBm)	Correction Factor (dB)	EIRP (dBm)	Limit (dBm)	Margin (dB)
1	1880.00	-27.90	10.60	1.10	11.70	33.00	-21.30

Mode		TX channel 19100					
Antenna Polarity & Test Distance: Horizontal at 3 M							
No.	Freq. (MHz)	Reading (dBm)	S.G Power Value (dBm)	Correction Factor (dB)	EIRP (dBm)	Limit (dBm)	Margin (dB)
1	1900.00	-21.50	18.90	1.10	20.00	33.00	-13.00
Antenna Polarity & Test Distance: Vertical at 3 M							
No.	Freq. (MHz)	Reading (dBm)	S.G Power Value (dBm)	Correction Factor (dB)	EIRP (dBm)	Limit (dBm)	Margin (dB)
1	1900.00	-27.10	11.20	1.10	12.30	33.00	-20.70

Note: EIRP (dBm) = S.G Power Value (dBm) + Correction Factor (dB).

**Modulation Type: 64QAM**

LTE Band 2, Channel Bandwidth 1.4MHz

Mode		TX channel 18607					
Antenna Polarity & Test Distance: Horizontal at 3 M							
No.	Freq. (MHz)	Reading (dBm)	S.G Power Value (dBm)	Correction Factor (dB)	EIRP (dBm)	Limit (dBm)	Margin (dB)
1	1850.70	-21.80	18.10	1.00	19.10	33.00	-13.90
Antenna Polarity & Test Distance: Vertical at 3 M							
No.	Freq. (MHz)	Reading (dBm)	S.G Power Value (dBm)	Correction Factor (dB)	EIRP (dBm)	Limit (dBm)	Margin (dB)
1	1850.70	-27.80	11.00	1.00	12.00	33.00	-21.00

Mode		TX channel 18900					
Antenna Polarity & Test Distance: Horizontal at 3 M							
No.	Freq. (MHz)	Reading (dBm)	S.G Power Value (dBm)	Correction Factor (dB)	EIRP (dBm)	Limit (dBm)	Margin (dB)
1	1880.00	-23.60	16.50	1.10	17.60	33.00	-15.40
Antenna Polarity & Test Distance: Vertical at 3 M							
No.	Freq. (MHz)	Reading (dBm)	S.G Power Value (dBm)	Correction Factor (dB)	EIRP (dBm)	Limit (dBm)	Margin (dB)
1	1880.00	-27.50	11.00	1.10	12.10	33.00	-20.90

Mode		TX channel 19193					
Antenna Polarity & Test Distance: Horizontal at 3 M							
No.	Freq. (MHz)	Reading (dBm)	S.G Power Value (dBm)	Correction Factor (dB)	EIRP (dBm)	Limit (dBm)	Margin (dB)
1	1909.30	-24.70	15.70	1.10	16.80	33.00	-16.20
Antenna Polarity & Test Distance: Vertical at 3 M							
No.	Freq. (MHz)	Reading (dBm)	S.G Power Value (dBm)	Correction Factor (dB)	EIRP (dBm)	Limit (dBm)	Margin (dB)
1	1909.30	-27.60	10.80	1.10	11.90	33.00	-21.10

Note: EIRP (dBm) = S.G Power Value (dBm) + Correction Factor (dB).



LTE Band 2, Channel Bandwidth 3MHz

Mode		TX channel 18615					
Antenna Polarity & Test Distance: Horizontal at 3 M							
No.	Freq. (MHz)	Reading (dBm)	S.G Power Value (dBm)	Correction Factor (dB)	EIRP (dBm)	Limit (dBm)	Margin (dB)
1	1851.50	-22.70	17.20	1.00	18.20	33.00	-14.80
Antenna Polarity & Test Distance: Vertical at 3 M							
No.	Freq. (MHz)	Reading (dBm)	S.G Power Value (dBm)	Correction Factor (dB)	EIRP (dBm)	Limit (dBm)	Margin (dB)
1	1851.50	-27.60	11.20	1.00	12.20	33.00	-20.80

Mode		TX channel 18900					
Antenna Polarity & Test Distance: Horizontal at 3 M							
No.	Freq. (MHz)	Reading (dBm)	S.G Power Value (dBm)	Correction Factor (dB)	EIRP (dBm)	Limit (dBm)	Margin (dB)
1	1880.00	-21.90	18.20	1.10	19.30	33.00	-13.70
Antenna Polarity & Test Distance: Vertical at 3 M							
No.	Freq. (MHz)	Reading (dBm)	S.G Power Value (dBm)	Correction Factor (dB)	EIRP (dBm)	Limit (dBm)	Margin (dB)
1	1880.00	-27.80	10.70	1.10	11.80	33.00	-21.20

Mode		TX channel 19185					
Antenna Polarity & Test Distance: Horizontal at 3 M							
No.	Freq. (MHz)	Reading (dBm)	S.G Power Value (dBm)	Correction Factor (dB)	EIRP (dBm)	Limit (dBm)	Margin (dB)
1	1908.50	-22.70	17.70	1.10	18.80	33.00	-14.20
Antenna Polarity & Test Distance: Vertical at 3 M							
No.	Freq. (MHz)	Reading (dBm)	S.G Power Value (dBm)	Correction Factor (dB)	EIRP (dBm)	Limit (dBm)	Margin (dB)
1	1908.50	-27.30	11.10	1.10	12.20	33.00	-20.80

Note: EIRP (dBm) = S.G Power Value (dBm) + Correction Factor (dB).

LTE Band 2, Channel Bandwidth 5MHz

Mode		TX channel 18625					
Antenna Polarity & Test Distance: Horizontal at 3 M							
No.	Freq. (MHz)	Reading (dBm)	S.G Power Value (dBm)	Correction Factor (dB)	EIRP (dBm)	Limit (dBm)	Margin (dB)
1	1852.50	-21.90	18.00	1.00	19.00	33.00	-14.00
Antenna Polarity & Test Distance: Vertical at 3 M							
No.	Freq. (MHz)	Reading (dBm)	S.G Power Value (dBm)	Correction Factor (dB)	EIRP (dBm)	Limit (dBm)	Margin (dB)
1	1852.50	-27.80	11.00	1.00	12.00	33.00	-21.00

Mode		TX channel 18900					
Antenna Polarity & Test Distance: Horizontal at 3 M							
No.	Freq. (MHz)	Reading (dBm)	S.G Power Value (dBm)	Correction Factor (dB)	EIRP (dBm)	Limit (dBm)	Margin (dB)
1	1880.00	-21.90	18.20	1.10	19.30	33.00	-13.70
Antenna Polarity & Test Distance: Vertical at 3 M							
No.	Freq. (MHz)	Reading (dBm)	S.G Power Value (dBm)	Correction Factor (dB)	EIRP (dBm)	Limit (dBm)	Margin (dB)
1	1880.00	-27.50	11.00	1.10	12.10	33.00	-20.90

Mode		TX channel 19175					
Antenna Polarity & Test Distance: Horizontal at 3 M							
No.	Freq. (MHz)	Reading (dBm)	S.G Power Value (dBm)	Correction Factor (dB)	EIRP (dBm)	Limit (dBm)	Margin (dB)
1	1907.50	-24.90	15.50	1.10	16.60	33.00	-16.40
Antenna Polarity & Test Distance: Vertical at 3 M							
No.	Freq. (MHz)	Reading (dBm)	S.G Power Value (dBm)	Correction Factor (dB)	EIRP (dBm)	Limit (dBm)	Margin (dB)
1	1907.50	-27.80	10.60	1.10	11.70	33.00	-21.30

Note: EIRP (dBm) = S.G Power Value (dBm) + Correction Factor (dB).

LTE Band 2, Channel Bandwidth 10MHz

Mode		TX channel 18650					
Antenna Polarity & Test Distance: Horizontal at 3 M							
No.	Freq. (MHz)	Reading (dBm)	S.G Power Value (dBm)	Correction Factor (dB)	EIRP (dBm)	Limit (dBm)	Margin (dB)
1	1855.00	-22.80	17.20	1.00	18.20	33.00	-14.80
Antenna Polarity & Test Distance: Vertical at 3 M							
No.	Freq. (MHz)	Reading (dBm)	S.G Power Value (dBm)	Correction Factor (dB)	EIRP (dBm)	Limit (dBm)	Margin (dB)
1	1855.00	-27.90	10.90	1.00	11.90	33.00	-21.10

Mode		TX channel 18900					
Antenna Polarity & Test Distance: Horizontal at 3 M							
No.	Freq. (MHz)	Reading (dBm)	S.G Power Value (dBm)	Correction Factor (dB)	EIRP (dBm)	Limit (dBm)	Margin (dB)
1	1880.00	-22.70	17.40	1.10	18.50	33.00	-14.50
Antenna Polarity & Test Distance: Vertical at 3 M							
No.	Freq. (MHz)	Reading (dBm)	S.G Power Value (dBm)	Correction Factor (dB)	EIRP (dBm)	Limit (dBm)	Margin (dB)
1	1880.00	-27.50	11.00	1.10	12.10	33.00	-20.90

Mode		TX channel 19150					
Antenna Polarity & Test Distance: Horizontal at 3 M							
No.	Freq. (MHz)	Reading (dBm)	S.G Power Value (dBm)	Correction Factor (dB)	EIRP (dBm)	Limit (dBm)	Margin (dB)
1	1905.00	-22.80	17.60	1.10	18.70	33.00	-14.30
Antenna Polarity & Test Distance: Vertical at 3 M							
No.	Freq. (MHz)	Reading (dBm)	S.G Power Value (dBm)	Correction Factor (dB)	EIRP (dBm)	Limit (dBm)	Margin (dB)
1	1905.00	-27.70	10.70	1.10	11.80	33.00	-21.20

Note: EIRP (dBm) = S.G Power Value (dBm) + Correction Factor (dB).

LTE Band 2, Channel Bandwidth 15MHz

Mode		TX channel 18675					
Antenna Polarity & Test Distance: Horizontal at 3 M							
No.	Freq. (MHz)	Reading (dBm)	S.G Power Value (dBm)	Correction Factor (dB)	EIRP (dBm)	Limit (dBm)	Margin (dB)
1	1857.50	-20.90	19.00	1.10	20.10	33.00	-12.90
Antenna Polarity & Test Distance: Vertical at 3 M							
No.	Freq. (MHz)	Reading (dBm)	S.G Power Value (dBm)	Correction Factor (dB)	EIRP (dBm)	Limit (dBm)	Margin (dB)
1	1857.50	-27.50	11.20	1.10	12.30	33.00	-20.70

Mode		TX channel 18900					
Antenna Polarity & Test Distance: Horizontal at 3 M							
No.	Freq. (MHz)	Reading (dBm)	S.G Power Value (dBm)	Correction Factor (dB)	EIRP (dBm)	Limit (dBm)	Margin (dB)
1	1880.00	-22.40	17.70	1.10	18.80	33.00	-14.20
Antenna Polarity & Test Distance: Vertical at 3 M							
No.	Freq. (MHz)	Reading (dBm)	S.G Power Value (dBm)	Correction Factor (dB)	EIRP (dBm)	Limit (dBm)	Margin (dB)
1	1880.00	-27.50	11.00	1.10	12.10	33.00	-20.90

Mode		TX channel 19125					
Antenna Polarity & Test Distance: Horizontal at 3 M							
No.	Freq. (MHz)	Reading (dBm)	S.G Power Value (dBm)	Correction Factor (dB)	EIRP (dBm)	Limit (dBm)	Margin (dB)
1	1902.50	-22.60	17.80	1.10	18.90	33.00	-14.10
Antenna Polarity & Test Distance: Vertical at 3 M							
No.	Freq. (MHz)	Reading (dBm)	S.G Power Value (dBm)	Correction Factor (dB)	EIRP (dBm)	Limit (dBm)	Margin (dB)
1	1902.50	-25.50	12.90	1.10	14.00	33.00	-19.00

Note: EIRP (dBm) = S.G Power Value (dBm) + Correction Factor (dB).

LTE Band 2, Channel Bandwidth 20MHz

Mode		TX channel 18700					
Antenna Polarity & Test Distance: Horizontal at 3 M							
No.	Freq. (MHz)	Reading (dBm)	S.G Power Value (dBm)	Correction Factor (dB)	EIRP (dBm)	Limit (dBm)	Margin (dB)
1	1860.00	-22.60	17.30	1.10	18.40	33.00	-14.60
Antenna Polarity & Test Distance: Vertical at 3 M							
No.	Freq. (MHz)	Reading (dBm)	S.G Power Value (dBm)	Correction Factor (dB)	EIRP (dBm)	Limit (dBm)	Margin (dB)
1	1860.00	-27.30	11.30	1.10	12.40	33.00	-20.60

Mode		TX channel 18900					
Antenna Polarity & Test Distance: Horizontal at 3 M							
No.	Freq. (MHz)	Reading (dBm)	S.G Power Value (dBm)	Correction Factor (dB)	EIRP (dBm)	Limit (dBm)	Margin (dB)
1	1880.00	-22.00	18.10	1.10	19.20	33.00	-13.80
Antenna Polarity & Test Distance: Vertical at 3 M							
No.	Freq. (MHz)	Reading (dBm)	S.G Power Value (dBm)	Correction Factor (dB)	EIRP (dBm)	Limit (dBm)	Margin (dB)
1	1880.00	-28.50	10.00	1.10	11.10	33.00	-21.90

Mode		TX channel 19100					
Antenna Polarity & Test Distance: Horizontal at 3 M							
No.	Freq. (MHz)	Reading (dBm)	S.G Power Value (dBm)	Correction Factor (dB)	EIRP (dBm)	Limit (dBm)	Margin (dB)
1	1900.00	-22.70	17.70	1.10	18.80	33.00	-14.20
Antenna Polarity & Test Distance: Vertical at 3 M							
No.	Freq. (MHz)	Reading (dBm)	S.G Power Value (dBm)	Correction Factor (dB)	EIRP (dBm)	Limit (dBm)	Margin (dB)
1	1900.00	-27.70	10.60	1.10	11.70	33.00	-21.30

Note: EIRP (dBm) = S.G Power Value (dBm) + Correction Factor (dB).

## 4.2 Modulation Characteristics Measurement

### 4.2.1 Limits of Modulation Characteristics

N/A

### 4.2.2 Test Procedure

Connect the EUT to Communication Simulator via the antenna connector, The frequency band is set as EUT supported Modulation and Channels, the EUT output is matched with 50 ohm load, the waveform quality and constellation of the EUT was tested.

### 4.2.3 Test Setup



### 4.2.4 Test Results

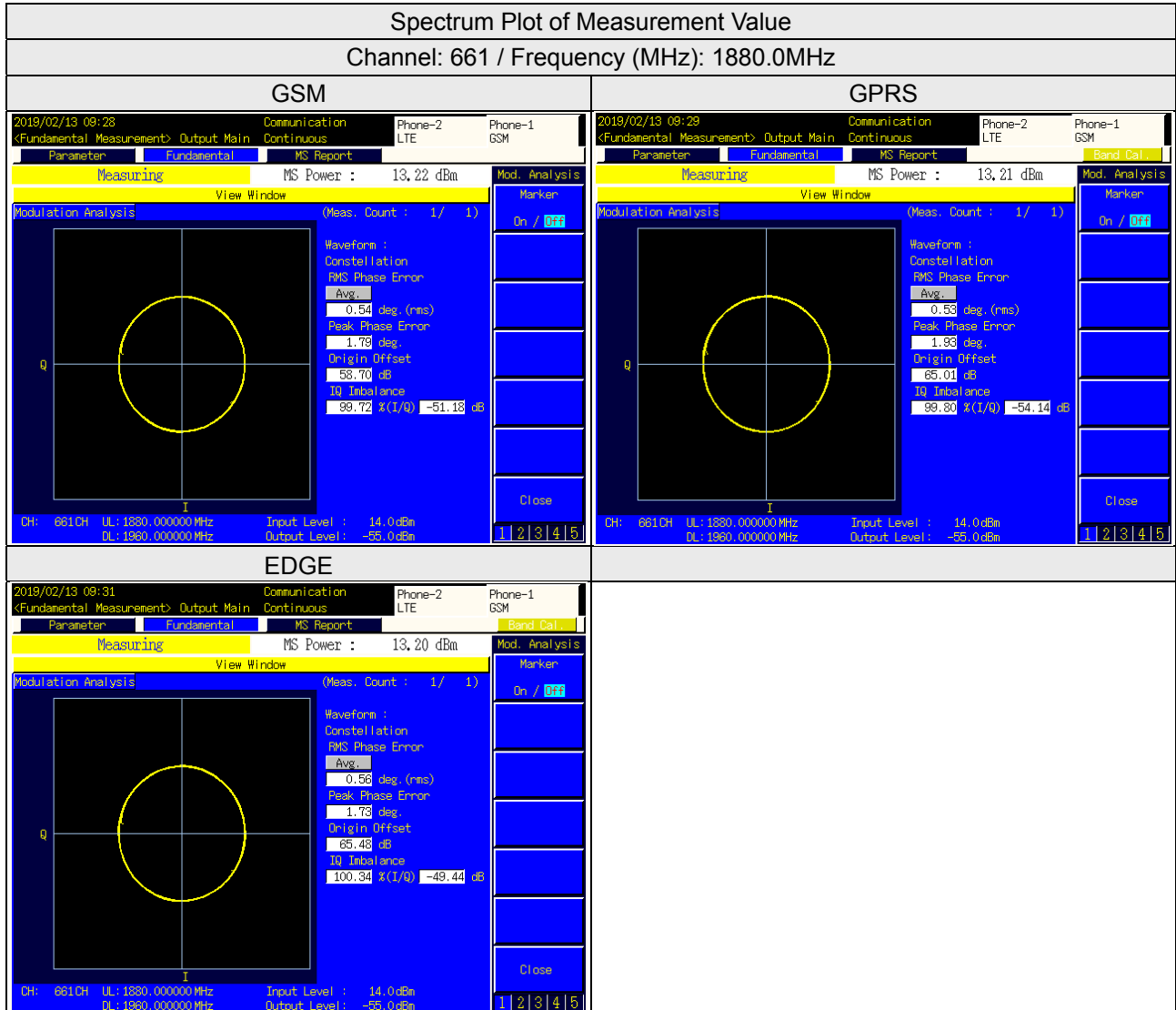

WCDMA Band 2

Spectrum Plot of Measurement Value

Channel: 9400 / Frequency (MHz): 1880.0MHz

WCDMA

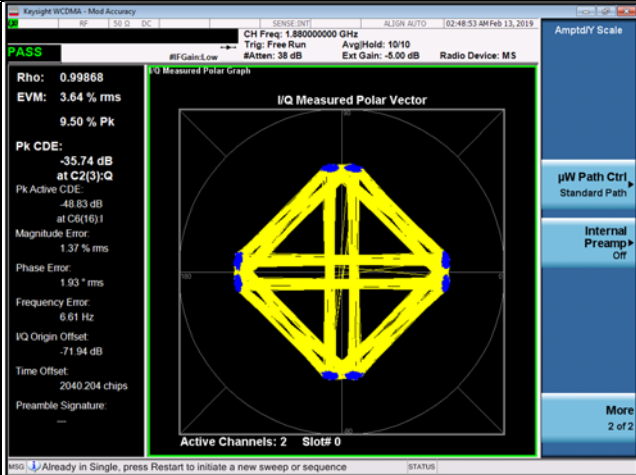

HSDPA

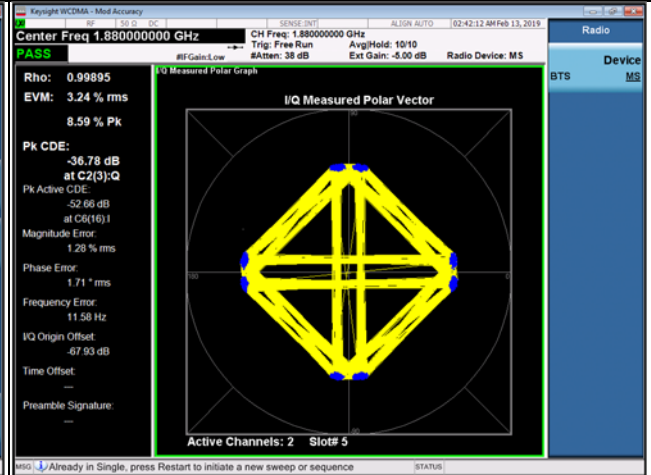

HSUPA

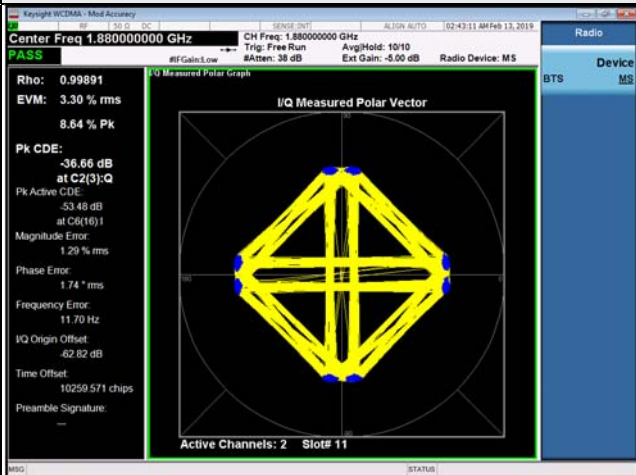



LTE Band 2

Spectrum Plot of Measurement Value

Channel: 18900 / Frequency (MHz): 1880.0MHz

QPSK

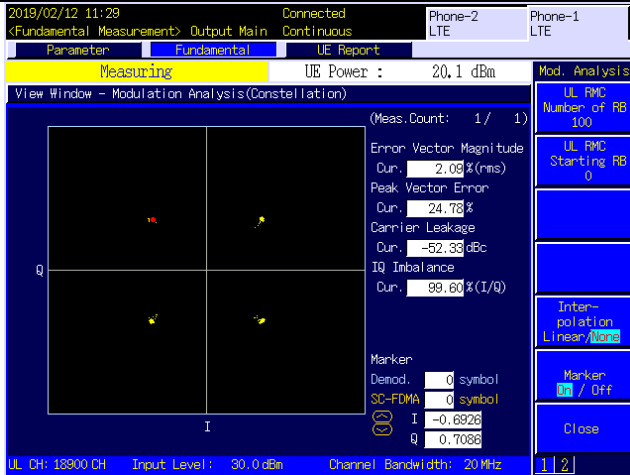

16QAM

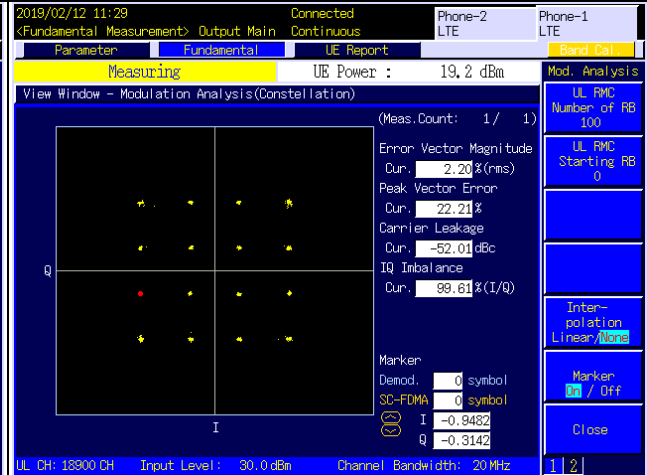

64QAM

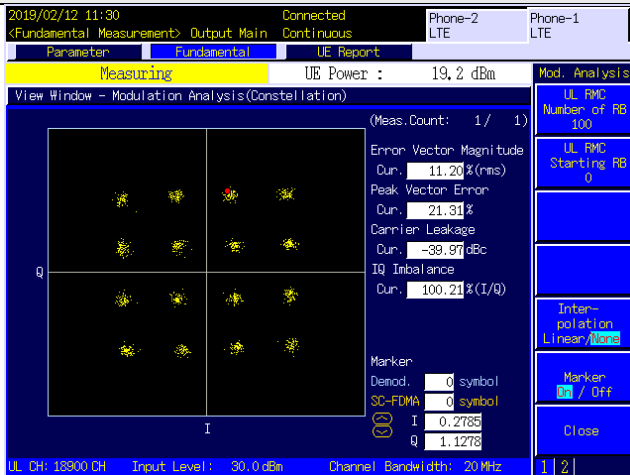

### 4.3 Frequency Stability Measurement

#### 4.3.1 Limits of Frequency Stability Measurement

The frequency stability shall be sufficient to ensure that the fundamental emission stays within the authorized frequency block.

#### 4.3.2 Test Procedure

- a. Device is placed at the oven room. The oven room could control the temperatures and humidity. Power warm up is at least 15 min and power applied should perform before recording frequency error.
- b. EUT is connected the external power supply to control the DC input power. The test voltage range is from minimum to maximum working voltage. Each step shall be record the frequency error rate.
- c. The temperature range step is 10 degrees in this test items. All temperature levels shall be hold the  $\pm 0.5$  °C during the measurement testing. The each temperature step shall be at least 0.5 hours, consider the EUT could be test under the stability condition.

Note: The frequency error was recorded frequency error from the communication simulator.

#### 4.3.3 Conducted Setup

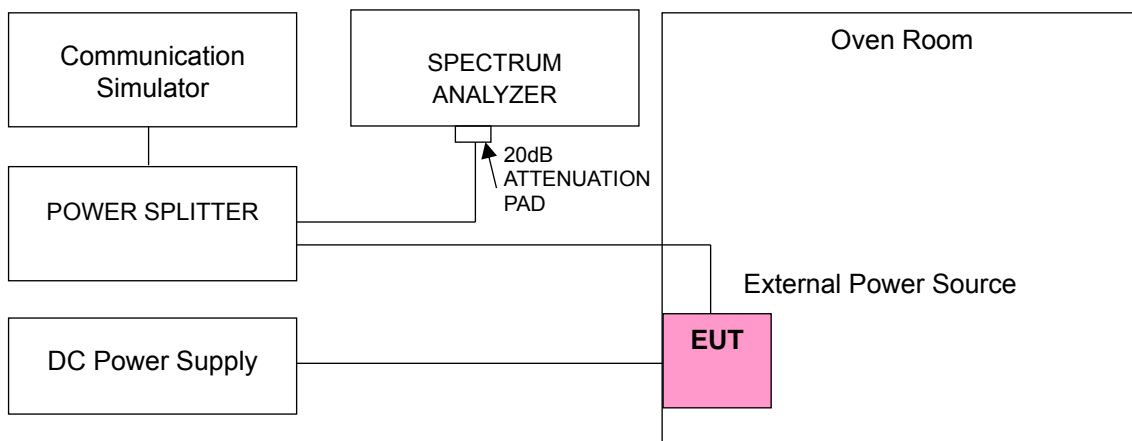

#### 4.3.4 Test Results

##### Frequency Error vs. Voltage

Voltage (Volts)	GSM 1900			
	Low Channel		High Channel	
	Frequency (MHz)	Frequency Error (ppm)	Frequency (MHz)	Frequency Error (ppm)
4.4275	1850.200002	0.001	1909.800002	0.001
3.85	1850.200002	0.001	1909.800003	0.002
3.2725	1850.200002	0.001	1909.800003	0.002

Note: The applicant defined the normal working voltage is from 3.2725Vdc to 4.4275Vdc.

##### Frequency Error vs. Temperature

Temp. (°C)	GSM 1900			
	Low Channel		High Channel	
	Frequency (MHz)	Frequency Error (ppm)	Frequency (MHz)	Frequency Error (ppm)
-30	1850.200001	0.001	1909.800003	0.002
-20	1850.200003	0.002	1909.800003	0.002
-10	1850.200001	0.001	1909.800002	0.001
0	1850.200003	0.002	1909.800003	0.002
10	1850.200002	0.001	1909.800003	0.001
20	1850.199998	-0.001	1909.799997	-0.002
30	1850.199999	-0.001	1909.799998	-0.001
40	1850.199997	-0.002	1909.799996	-0.002
50	1850.199997	-0.002	1909.799999	-0.001
55	1850.199998	-0.001	1909.799997	-0.001

### Frequency Error vs. Voltage

Voltage (Volts)	EDGE 1900			
	Low Channel		High Channel	
	Frequency (MHz)	Frequency Error (ppm)	Frequency (MHz)	Frequency Error (ppm)
4.4275	1850.200001	0.001	1909.800002	0.001
3.85	1850.200001	0.001	1909.800003	0.002
3.2725	1850.200003	0.002	1909.800002	0.001

Note: The applicant defined the normal working voltage is from 3.2725Vdc to 4.4275Vdc.

### Frequency Error vs. Temperature

Temp. (°C)	EDGE 1900			
	Low Channel		High Channel	
	Frequency (MHz)	Frequency Error (ppm)	Frequency (MHz)	Frequency Error (ppm)
-30	1850.200003	0.001	1909.800003	0.002
-20	1850.200004	0.002	1909.800001	0.001
-10	1850.200003	0.002	1909.800004	0.002
0	1850.200002	0.001	1909.800003	0.001
10	1850.200001	0.001	1909.800001	0.001
20	1850.199999	-0.001	1909.799999	-0.001
30	1850.199997	-0.002	1909.799997	-0.001
40	1850.199999	-0.001	1909.799999	-0.001
50	1850.199997	-0.001	1909.799998	-0.001
55	1850.199998	-0.001	1909.799998	-0.001

### Frequency Error vs. Voltage

Voltage (Volts)	WCDMA Band 2			
	Low Channel		High Channel	
	Frequency (MHz)	Frequency Error (ppm)	Frequency (MHz)	Frequency Error (ppm)
4.4275	1852.400004	0.002	1907.600003	0.001
3.85	1852.400003	0.001	1907.600003	0.001
3.2725	1852.400003	0.001	1907.600002	0.001

Note: The applicant defined the normal working voltage is from 3.2725Vdc to 4.4275Vdc.

### Frequency Error vs. Temperature

Temp. (°C)	WCDMA Band 2			
	Low Channel		High Channel	
	Frequency (MHz)	Frequency Error (ppm)	Frequency (MHz)	Frequency Error (ppm)
-30	1852.400003	0.002	1907.600004	0.002
-20	1852.400004	0.002	1907.600002	0.001
-10	1852.400003	0.001	1907.600001	0.001
0	1852.400004	0.002	1907.600004	0.002
10	1852.400002	0.001	1907.600003	0.002
20	1852.399996	-0.002	1907.599999	-0.001
30	1852.399998	-0.001	1907.599997	-0.002
40	1852.399997	-0.002	1907.599997	-0.001
50	1852.399999	-0.001	1907.599996	-0.002
55	1852.399996	-0.002	1907.599998	-0.001

Frequency Error vs. Voltage

Voltage (Volts)	LTE Band 2			
	Channel Bandwidth: 1.4 MHz			
	Low Channel		High Channel	
	Frequency (MHz)	Frequency Error (ppm)	Frequency (MHz)	Frequency Error (ppm)
4.4275	1850.700002	0.001	1909.300000	0.001
3.85	1850.700004	0.002	1909.300001	0.001
3.2725	1850.700001	0.001	1909.300002	0.001

Note: The applicant defined the normal working voltage is from 3.2725Vdc to 4.4275Vdc.

Frequency Error vs. Temperature

Temp. (°C)	LTE Band 2			
	Channel Bandwidth: 1.4 MHz			
	Low Channel		High Channel	
	Frequency (MHz)	Frequency Error (ppm)	Frequency (MHz)	Frequency Error (ppm)
-30	1850.700002	0.001	1909.300003	0.001
-20	1850.700002	0.001	1909.300001	0.001
-10	1850.700003	0.002	1909.300003	0.001
0	1850.700002	0.001	1909.300003	0.001
10	1850.700003	0.002	1909.300001	0.001
20	1850.699997	-0.002	1909.299997	-0.001
30	1850.699996	-0.002	1909.299997	-0.002
40	1850.699997	-0.002	1909.299998	-0.001
50	1850.699998	-0.001	1909.299997	-0.001
55	1850.699997	-0.002	1909.299997	-0.002

Frequency Error vs. Voltage

Voltage (Volts)	LTE Band 2			
	Channel Bandwidth: 3 MHz			
	Low Channel		High Channel	
	Frequency (MHz)	Frequency Error (ppm)	Frequency (MHz)	Frequency Error (ppm)
4.4275	1851.500003	0.001	1907.500003	0.002
3.85	1851.500002	0.001	1907.500002	0.001
3.2725	1851.500002	0.001	1907.500004	0.002

Note: The applicant defined the normal working voltage is from 3.2725Vdc to 4.4275Vdc.

Frequency Error vs. Temperature

Temp. (°C)	LTE Band 2			
	Channel Bandwidth: 3 MHz			
	Low Channel		High Channel	
	Frequency (MHz)	Frequency Error (ppm)	Frequency (MHz)	Frequency Error (ppm)
-30	1851.500002	0.001	1907.500003	0.002
-20	1851.500002	0.001	1907.500002	0.001
-10	1851.500004	0.002	1907.500003	0.001
0	1851.500004	0.002	1907.500003	0.002
10	1851.500002	0.001	1907.500003	0.002
20	1851.499996	-0.002	1907.499997	-0.001
30	1851.499998	-0.001	1907.499998	-0.001
40	1851.499999	-0.001	1907.499997	-0.001
50	1851.499997	-0.002	1907.499997	-0.001
55	1851.499998	-0.001	1907.499996	-0.002

Frequency Error vs. Voltage

Voltage (Volts)	LTE Band 2			
	Channel Bandwidth: 5 MHz			
	Low Channel		High Channel	
	Frequency (MHz)	Frequency Error (ppm)	Frequency (MHz)	Frequency Error (ppm)
4.4275	1852.500003	0.002	1907.500002	0.001
3.85	1852.500001	0.001	1907.500002	0.001
3.2725	1852.500001	0.001	1907.500004	0.002

Note: The applicant defined the normal working voltage is from 3.2725Vdc to 4.4275Vdc.

Frequency Error vs. Temperature

Temp. (°C)	LTE Band 2			
	Channel Bandwidth: 5 MHz			
	Low Channel		High Channel	
	Frequency (MHz)	Frequency Error (ppm)	Frequency (MHz)	Frequency Error (ppm)
-30	1852.500004	0.002	1907.500002	0.001
-20	1852.500002	0.001	1907.500002	0.001
-10	1852.500001	0.001	1907.500004	0.002
0	1852.500004	0.002	1907.500002	0.001
10	1852.500003	0.002	1907.500002	0.001
20	1852.499997	-0.001	1907.499997	-0.002
30	1852.499997	-0.002	1907.499997	-0.002
40	1852.499997	-0.002	1907.499998	-0.001
50	1852.499999	-0.001	1907.499998	-0.001
55	1852.499999	-0.001	1907.499999	-0.001



Frequency Error vs. Voltage

Voltage (Volts)	LTE Band 2			
	Channel Bandwidth: 10 MHz			
	Low Channel		High Channel	
	Frequency (MHz)	Frequency Error (ppm)	Frequency (MHz)	Frequency Error (ppm)
4.4275	1855.000003	0.002	1905.000004	0.002
3.85	1855.000004	0.002	1905.000004	0.002
3.2725	1855.000003	0.001	1905.000004	0.002

Note: The applicant defined the normal working voltage is from 3.2725Vdc to 4.4275Vdc.

Frequency Error vs. Temperature

Temp. (°C)	LTE Band 2			
	Channel Bandwidth: 10 MHz			
	Low Channel		High Channel	
	Frequency (MHz)	Frequency Error (ppm)	Frequency (MHz)	Frequency Error (ppm)
-30	1855.000003	0.001	1905.000002	0.001
-20	1855.000003	0.002	1905.000002	0.001
-10	1855.000003	0.002	1905.000002	0.001
0	1855.000001	0.001	1905.000002	0.001
10	1855.000002	0.001	1905.000001	0.001
20	1854.999997	-0.002	1904.999996	-0.002
30	1854.999998	-0.001	1904.999998	-0.001
40	1854.999997	-0.002	1904.999997	-0.002
50	1854.999998	-0.001	1904.999998	-0.001
55	1854.999999	-0.001	1904.999998	-0.001

Frequency Error vs. Voltage

Voltage (Volts)	LTE Band 2			
	Channel Bandwidth: 15 MHz			
	Low Channel		High Channel	
	Frequency (MHz)	Frequency Error (ppm)	Frequency (MHz)	Frequency Error (ppm)
4.4275	1857.500002	0.001	1902.500002	0.001
3.85	1857.500003	0.002	1902.500004	0.002
3.2725	1857.500004	0.002	1902.500002	0.001

Note: The applicant defined the normal working voltage is from 3.2725Vdc to 4.4275Vdc.

Frequency Error vs. Temperature

Temp. (°C)	LTE Band 2			
	Channel Bandwidth: 15 MHz			
	Low Channel		High Channel	
	Frequency (MHz)	Frequency Error (ppm)	Frequency (MHz)	Frequency Error (ppm)
-30	1857.500002	0.001	1902.500002	0.001
-20	1857.500004	0.002	1902.500004	0.002
-10	1857.500003	0.002	1902.500002	0.001
0	1857.500003	0.001	1902.500003	0.001
10	1857.500002	0.001	1902.500004	0.002
20	1857.499998	-0.001	1902.499999	-0.001
30	1857.499997	-0.002	1902.499997	-0.001
40	1857.499998	-0.001	1902.499997	-0.002
50	1857.499999	-0.001	1902.499998	-0.001
55	1857.499996	-0.002	1902.499998	-0.001

Frequency Error vs. Voltage

Voltage (Volts)	LTE Band 2			
	Channel Bandwidth: 20 MHz			
	Low Channel		High Channel	
	Frequency (MHz)	Frequency Error (ppm)	Frequency (MHz)	Frequency Error (ppm)
4.4275	1860.000001	0.001	1900.000002	0.001
3.85	1860.000004	0.002	1900.000004	0.002
3.2725	1860.000004	0.002	1900.000002	0.001

Note: The applicant defined the normal working voltage is from 3.2725Vdc to 4.4275Vdc.

Frequency Error vs. Temperature

Temp. (°C)	LTE Band 2			
	Channel Bandwidth: 20 MHz			
	Low Channel		High Channel	
	Frequency (MHz)	Frequency Error (ppm)	Frequency (MHz)	Frequency Error (ppm)
-30	1860.000004	0.002	1900.000002	0.001
-20	1860.000002	0.001	1900.000004	0.002
-10	1860.000004	0.002	1900.000002	0.001
0	1860.000002	0.001	1900.000001	0.001
10	1860.000002	0.001	1900.000003	0.002
20	1859.999998	-0.001	1899.999998	-0.001
30	1859.999998	-0.001	1899.999997	-0.001
40	1859.999999	-0.001	1899.999998	-0.001
50	1859.999997	-0.001	1899.999996	-0.002
55	1859.999998	-0.001	1899.999998	-0.001

## 4.4 Occupied Bandwidth Measurement

### 4.4.1 Test Procedure

The EUT makes a call to the communication simulator. All measurements were done at low, middle and high operational frequency range. The communication simulator station system controlled a EUT to export maximum output power under transmission mode and specific channel frequency. Use OBW measurement function of Spectrum analyzer to measure 99 % occupied bandwidth.

### 4.4.2 Test Setup

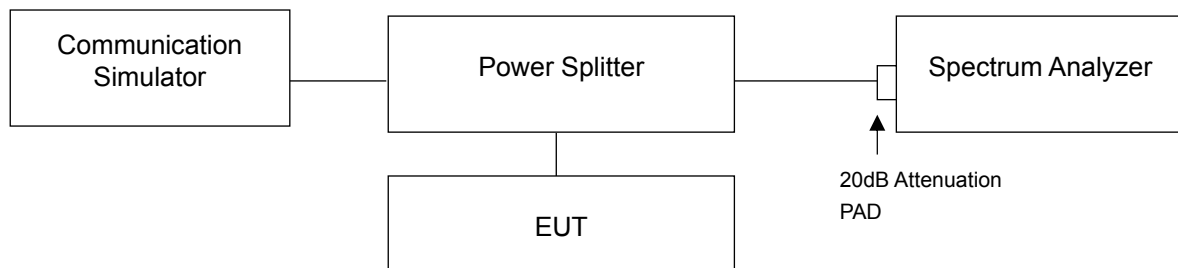

### 4.4.3 Test Result

#### Occupied Bandwidth GSM

Channel	Frequency (MHz)	99% Occupied Bandwidth (kHz)		
		GSM	GPRS	EDGE
512	1850.2	240.00	240.00	240.00
661	1880.0	230.00	240.00	240.00
810	1909.8	240.00	240.00	240.00

#### Spectrum Plot of Worst Value

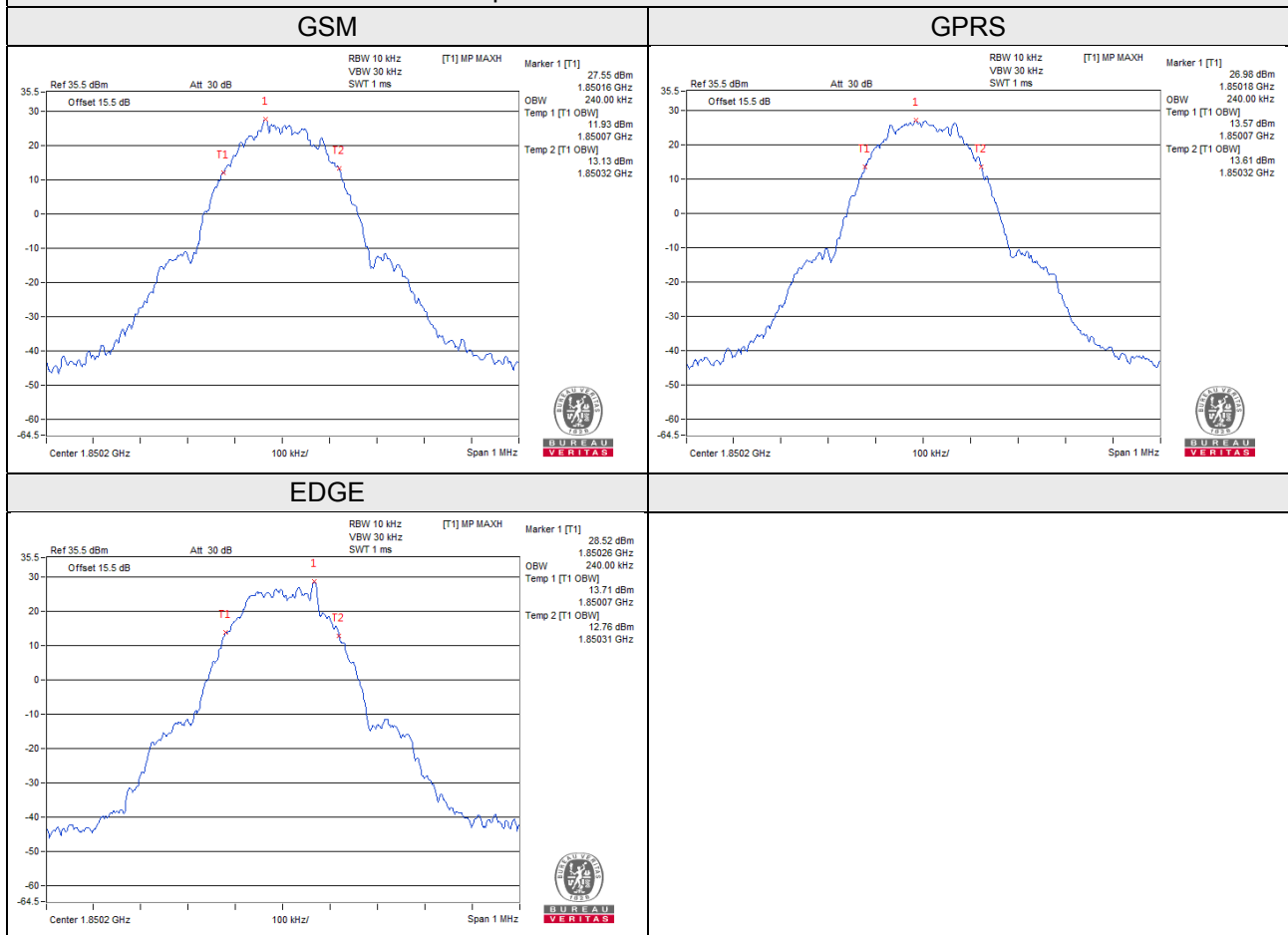

WCDMA Band 2

Channel	Frequency (MHz)	99% Occupied Bandwidth (MHz)		
		WCDMA	HSDPA	HSUPA
9262	1852.4	4.14	4.15	4.15
9400	1880.0	4.14	4.15	4.15
9538	1907.6	4.14	4.13	4.14

Spectrum Plot of Worst Value

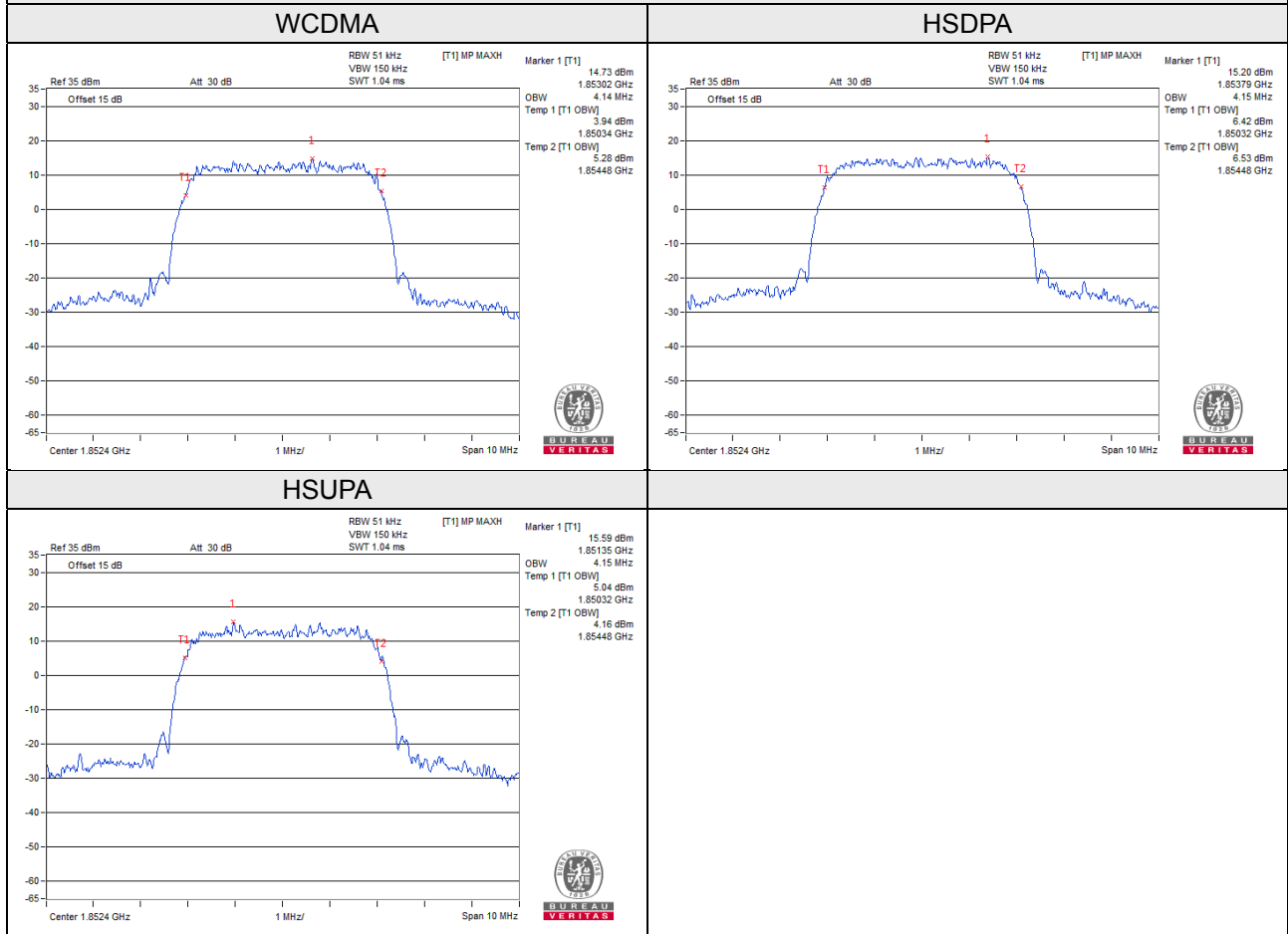

LTE Band 2

LTE Band 2, Channel Bandwidth 1.4MHz				
Channel	Frequency (MHz)	99% Occupied Bandwidth (MHz)		
		QPSK	16QAM	64QAM
18607	1850.7	1.09	1.09	1.09
18900	1880.0	1.09	1.09	1.09
19193	1909.3	1.09	1.09	1.09
LTE Band 2, Channel Bandwidth 3MHz				
Channel	Frequency (MHz)	99% Occupied Bandwidth (MHz)		
		QPSK	16QAM	64QAM
18615	1851.5	2.70	2.70	2.70
18900	1880.0	2.70	2.69	2.70
19185	1908.5	2.70	2.69	2.70
LTE Band 2, Channel Bandwidth 5MHz				
Channel	Frequency (MHz)	99% Occupied Bandwidth (MHz)		
		QPSK	16QAM	64QAM
18625	1852.5	4.50	4.49	4.49
18900	1880.0	4.49	4.49	4.50
19175	1907.5	4.48	4.49	4.49
LTE Band 2, Channel Bandwidth 10MHz				
Channel	Frequency (MHz)	99% Occupied Bandwidth (MHz)		
		QPSK	16QAM	64QAM
18650	1855.0	8.98	8.98	8.98
18900	1880.0	8.96	8.96	8.95
19150	1905.0	8.96	8.96	8.96
LTE Band 2, Channel Bandwidth 15MHz				
Channel	Frequency (MHz)	99% Occupied Bandwidth (MHz)		
		QPSK	16QAM	64QAM
18675	1857.5	13.49	13.48	13.47
18900	1880.0	13.42	13.41	13.41
19125	1902.5	13.47	13.47	13.45

LTE Band 2, Channel Bandwidth 20MHz

Channel	Frequency (MHz)	99% Occupied Bandwidth (MHz)		
		QPSK	16QAM	64QAM
18700	1860.0	17.99	18.01	17.99
18900	1880.0	17.86	17.87	17.87
19100	1900.0	18.00	18.02	18.00



### Spectrum Plot of Worst Value

1.4MHz / 16QAM



3MHz / 64QAM

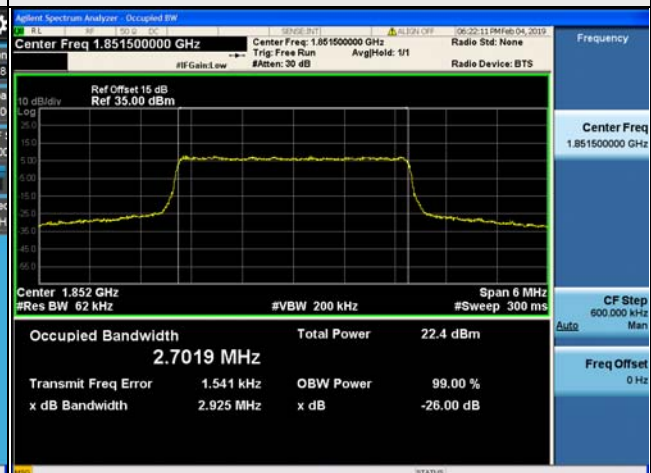

5MHz / 64QAM

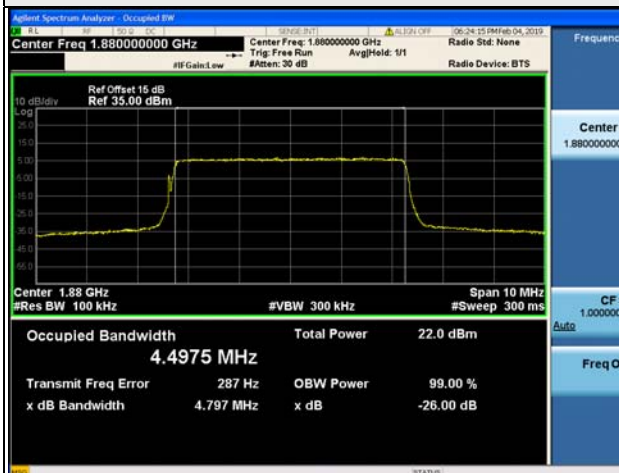

10MHz / QPSK



15MHz / QPSK



20MHz / 16QAM



26dB Bandwidth  
GSM

Channel	Frequency (MHz)	26dB Bandwidth (kHz)		
		GSM	GPRS	EDGE
512	1850.2	310.37	317.65	312.25
661	1880.0	312.31	315.08	316.28
810	1909.8	311.52	304.04	318.09

Spectrum Plot of Worst Value

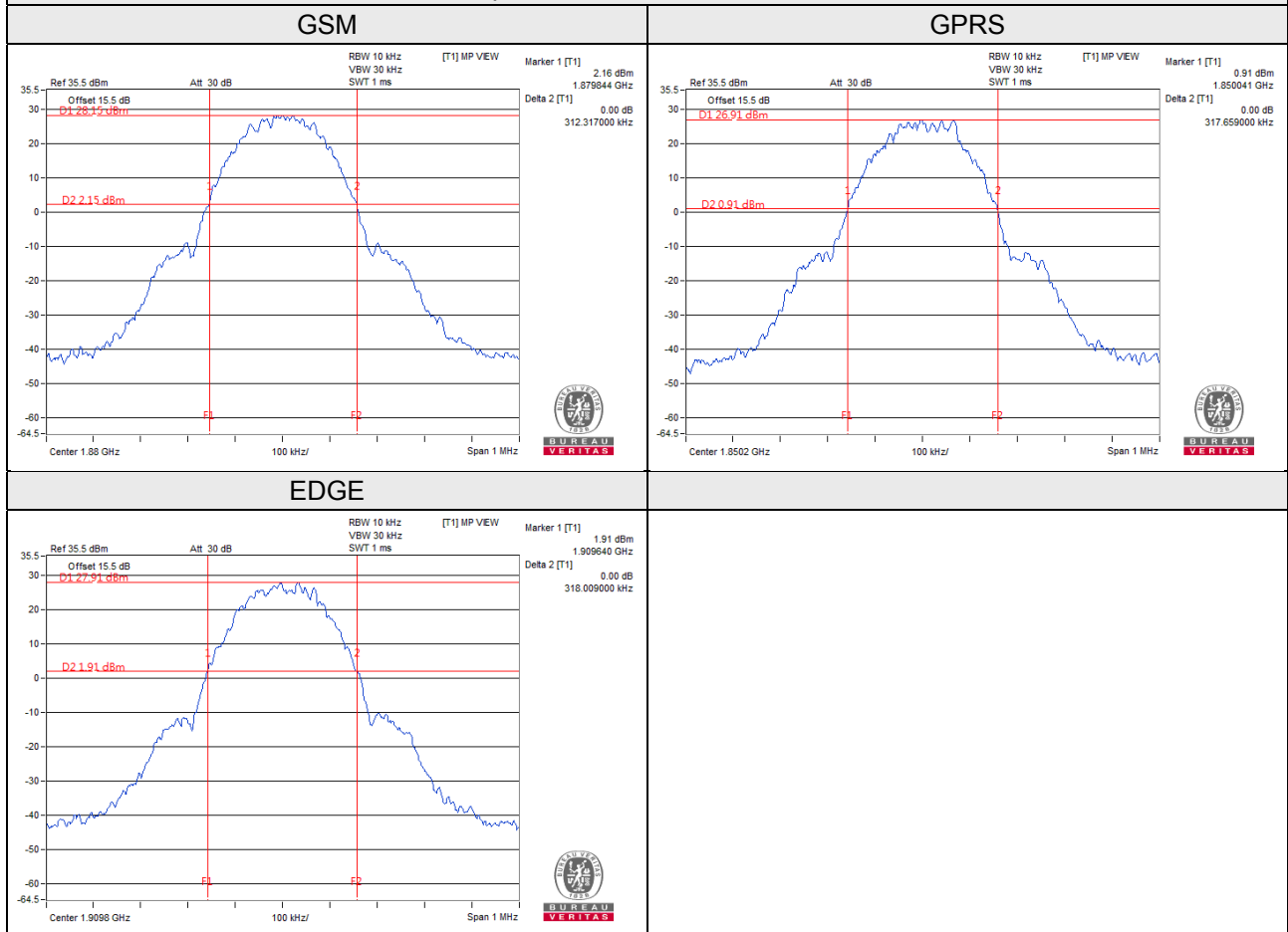

WCDMA Band 2

Channel	Frequency (MHz)	26dB Bandwidth (MHz)		
		WCDMA	HSDPA	HSUPA
9262	1852.4	4.68	4.71	4.68
9400	1880.0	4.74	4.72	4.72
9538	1907.6	4.71	4.72	4.72

Spectrum Plot of Worst Value

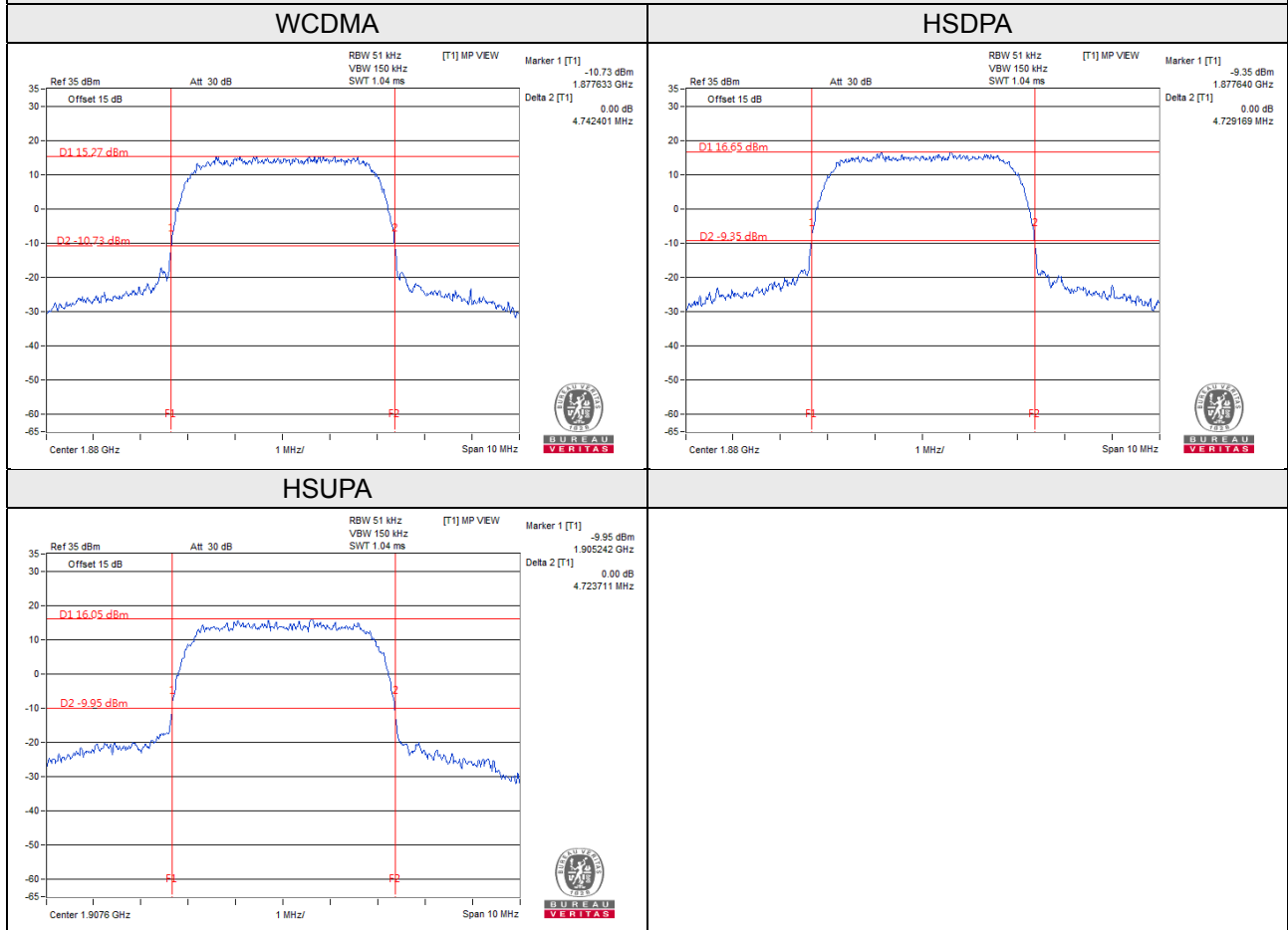

LTE Band 2

LTE Band 2, Channel Bandwidth 1.4MHz				
Channel	Frequency (MHz)	26dB Bandwidth (MHz)		
		QPSK	16QAM	64QAM
18607	1850.7	1.22	1.23	1.22
18900	1880.0	1.22	1.22	1.22
19193	1909.3	1.22	1.22	1.22
LTE Band 2, Channel Bandwidth 3MHz				
Channel	Frequency (MHz)	26dB Bandwidth (MHz)		
		QPSK	16QAM	64QAM
18615	1851.5	2.93	2.94	2.93
18900	1880.0	2.92	2.93	2.93
19185	1908.5	2.93	2.93	2.92
LTE Band 2, Channel Bandwidth 5MHz				
Channel	Frequency (MHz)	26dB Bandwidth (MHz)		
		QPSK	16QAM	64QAM
18625	1852.5	5.49	4.82	4.82
18900	1880.0	4.81	4.80	4.80
19175	1907.5	4.79	4.79	4.79
LTE Band 2, Channel Bandwidth 10MHz				
Channel	Frequency (MHz)	26dB Bandwidth (MHz)		
		QPSK	16QAM	64QAM
18650	1855.0	9.53	9.55	9.53
18900	1880.0	9.49	9.50	9.50
19150	1905.0	9.49	9.51	9.49
LTE Band 2, Channel Bandwidth 15MHz				
Channel	Frequency (MHz)	26dB Bandwidth (MHz)		
		QPSK	16QAM	64QAM
18675	1857.5	14.27	14.29	14.25
18900	1880.0	14.21	14.21	14.23
19125	1902.5	14.24	14.25	14.24

LTE Band 2, Channel Bandwidth 20MHz				
Channel	Frequency (MHz)	26dB Bandwidth (MHz)		
		QPSK	16QAM	64QAM
18700	1860.0	19.05	19.06	19.06
18900	1880.0	18.97	18.99	19.01
19100	1900.0	19.05	19.04	19.05

### Spectrum Plot of Worst Value

**1.4MHz / 16QAM**

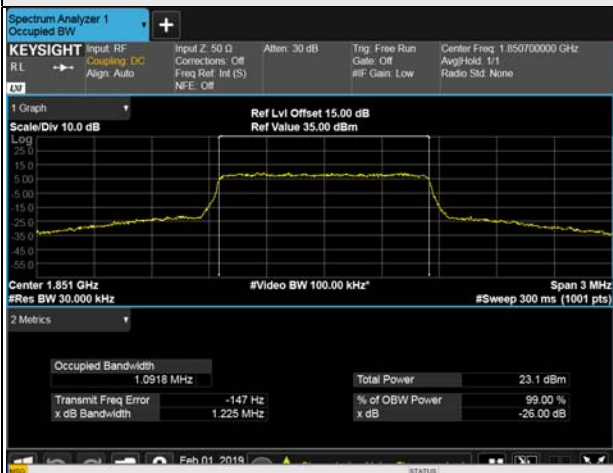

**3MHz / 16QAM**



**5MHz / QPSK**



**10MHz / 16QAM**



**15MHz / 16QAM**



**20MHz / 16QAM**



## 4.5 Band Edge Measurement

### 4.5.1 Limits of Band Edge Measurement

Power of any emission outside of the authorized operating frequency ranges must be attenuated below the transmitting power (P) by a factor of at least  $43 + 10 \log(P)$  dB. In the 1 MHz bands immediately outside and adjacent to the frequency block a resolution bandwidth of at least one percent of the emission bandwidth of the fundamental emission of the transmitter may be employed.

### 4.5.2 Test Setup

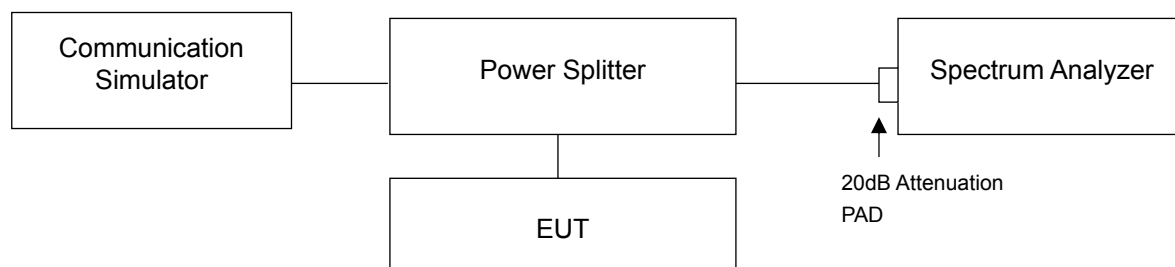

### 4.5.3 Test Procedures

- a. All measurements were done at low and high operational frequency range.
- b. The center frequency of spectrum is the band edge frequency and span is 1.5MHz. RB of the spectrum is 10kHz and VB of the spectrum is 30kHz (GSM / GPRS / EDGE).
- c. The center frequency of spectrum is the band edge frequency and span is 10MHz. RB of the spectrum is 51kHz and VB of the spectrum is 150kHz (WCDMA / HSDPA / HSUPA).
- d. The center frequency of spectrum is the band edge frequency and span is 1MHz. RB of the spectrum is 15kHz and VB of the spectrum is 51kHz (LTE Channel Bandwidth 1.4MHz).
- e. The center frequency of spectrum is the band edge frequency and span is 1MHz. RB of the spectrum is 30kHz and VB of the spectrum is 100kHz (LTE Channel Bandwidth 3MHz).
- f. The center frequency of spectrum is the band edge frequency and span is 1MHz. RB of the spectrum is 62kHz and VB of the spectrum is 200kHz (LTE Channel Bandwidth 5MHz).
- g. The center frequency of spectrum is the band edge frequency and span is 1MHz. RB of the spectrum is 100kHz and VB of the spectrum is 300kHz (LTE Channel Bandwidth 10MHz).
- h. The center frequency of spectrum is the band edge frequency and span is 1MHz. RB of the spectrum is 150kHz and VB of the spectrum is 470kHz (LTE Channel Bandwidth 15MHz).
- i. The center frequency of spectrum is the band edge frequency and span is 1MHz. RB of the spectrum is 200kHz and VB of the spectrum is 1MHz (LTE Channel Bandwidth 20MHz).
- j. Record the max trace plot into the test report.

### 4.5.4 Test Results

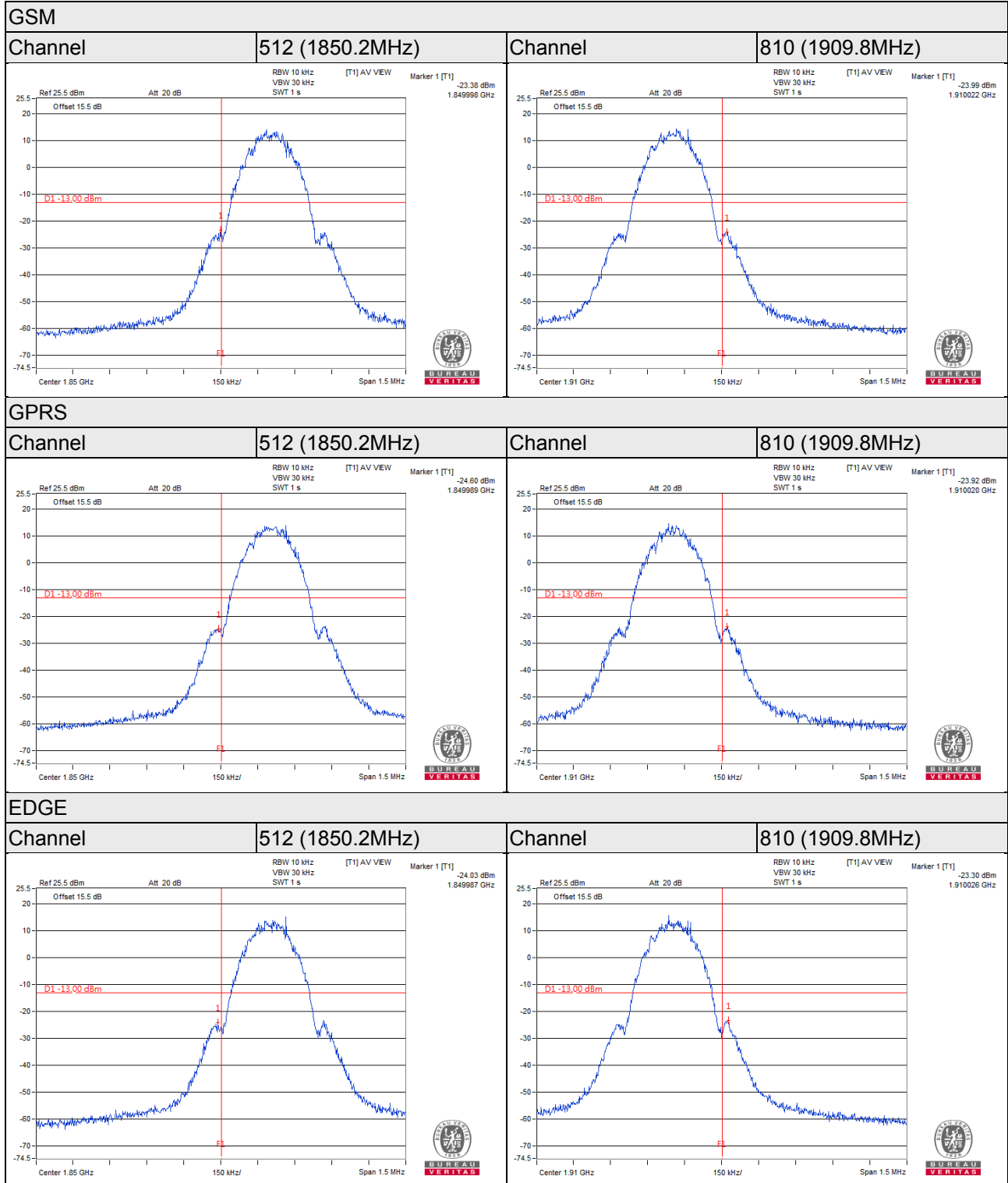



### WCDMA

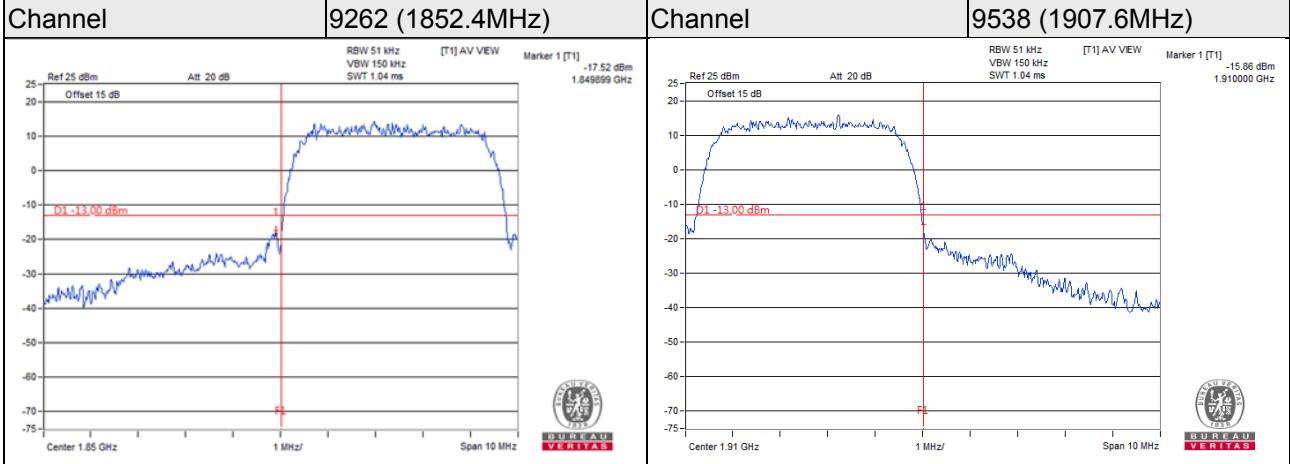

### HSDPA

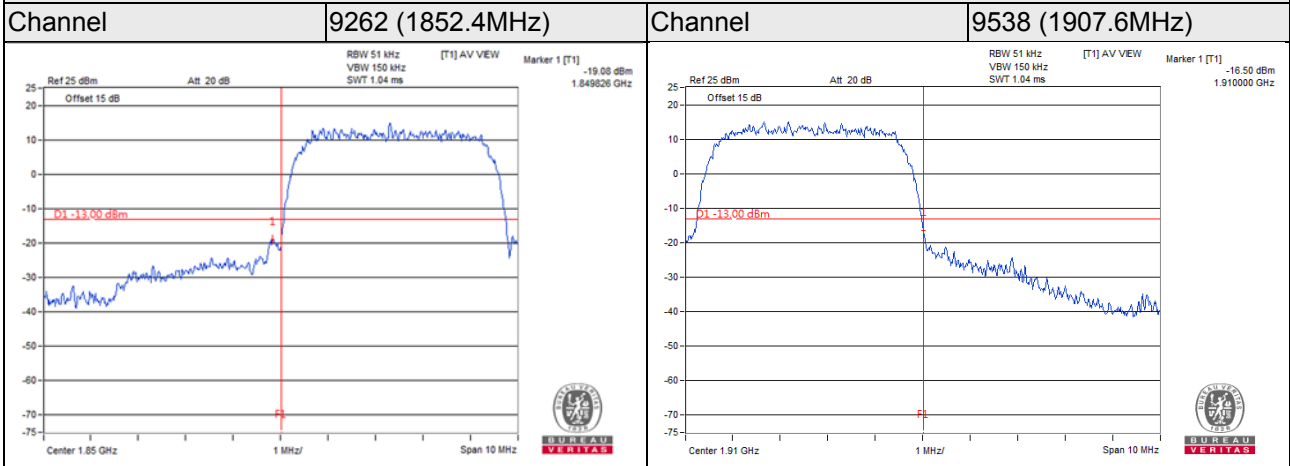

### HSUPA

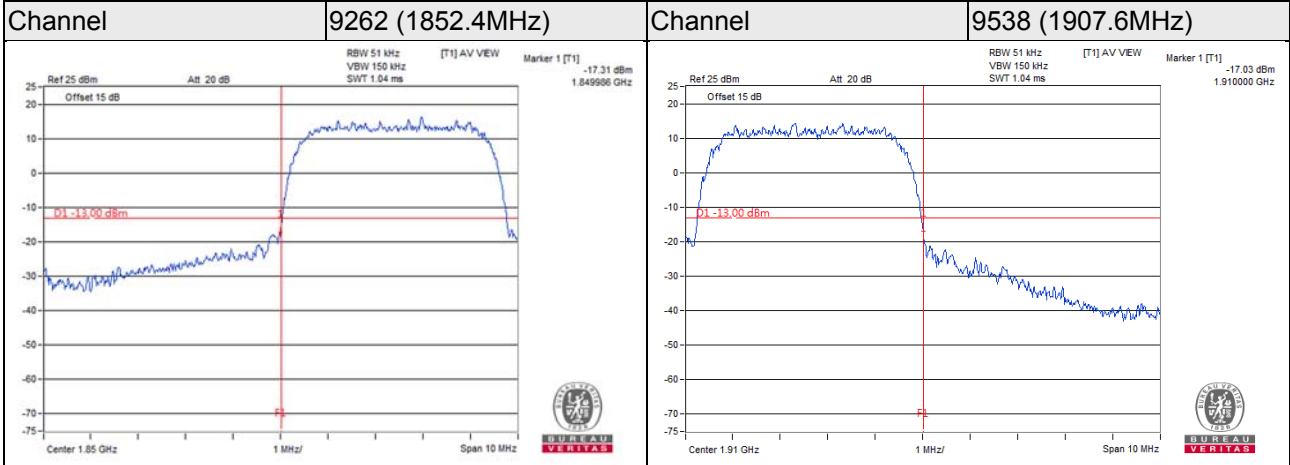

LTE Band 2, Channel Bandwidth 1.4MHz

Channel 18607  
(1850.70MHz)

QPSK

1 RB / 0 RB Offset

Channel 19193  
(1909.30MHz)

QPSK

1 RB / 5 RB Offset

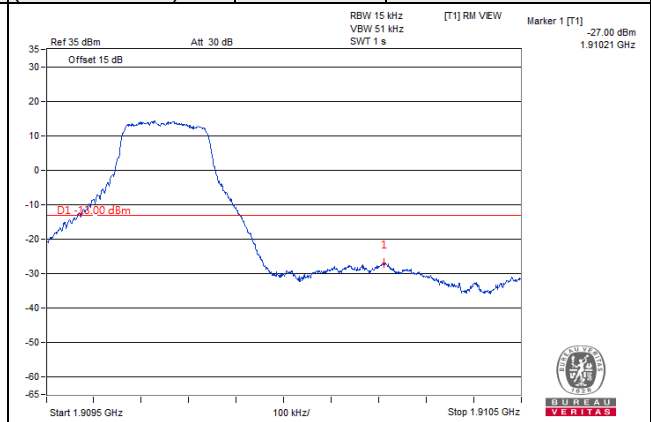
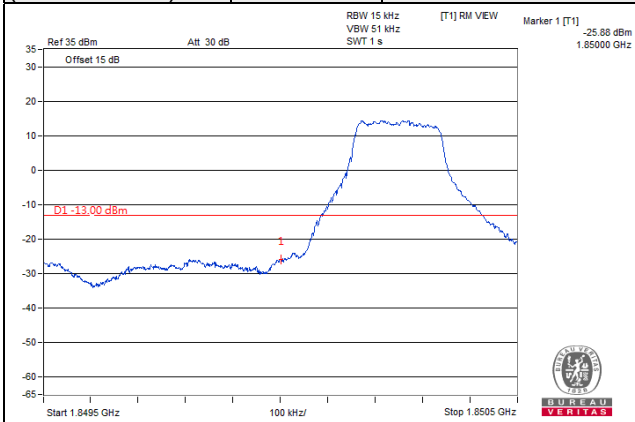

Channel 18607  
(1850.70MHz)

QPSK

6 RB / 0 RB Offset

Channel 19193  
(1909.30MHz)

QPSK

6 RB / 0 RB Offset

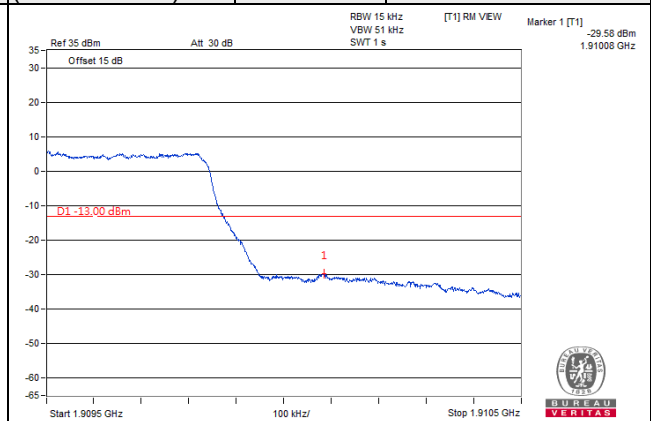
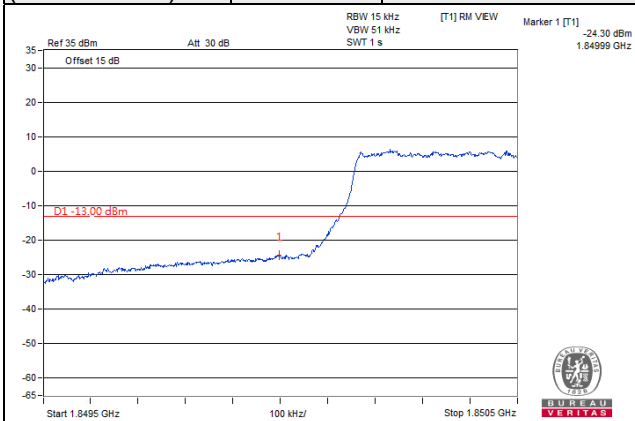

**LTE Band 2, Channel Bandwidth 3MHz**

<b>Channel 18615 (1851.50MHz)</b>	<b>QPSK</b>	<b>1 RB / 0 RB Offset</b>	<b>Channel 19185 (1908.50MHz)</b>	<b>QPSK</b>	<b>1 RB / 14 RB Offset</b>
---------------------------------------	-------------	---------------------------	---------------------------------------	-------------	----------------------------

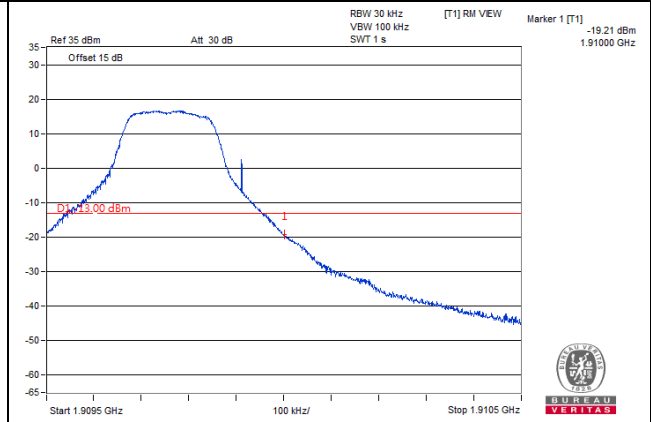
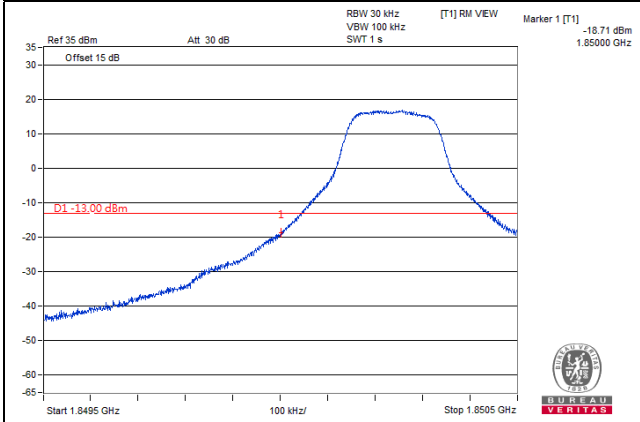

<b>Channel 18615 (1851.50MHz)</b>	<b>QPSK</b>	<b>15 RB / 0 RB Offset</b>
---------------------------------------	-------------	----------------------------

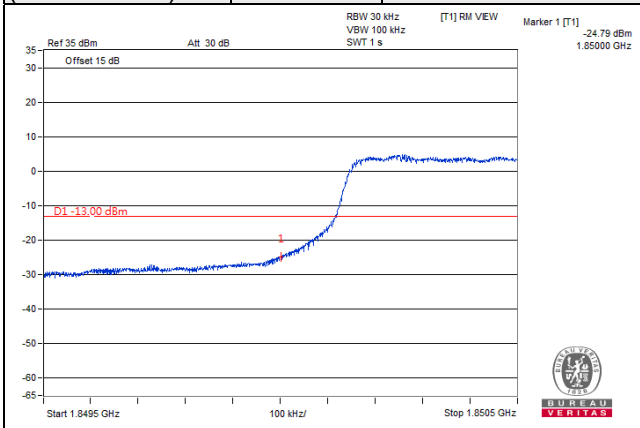

<b>Channel 19185 (1908.50MHz)</b>	<b>QPSK</b>	<b>15 RB / 0 RB Offset</b>
---------------------------------------	-------------	----------------------------

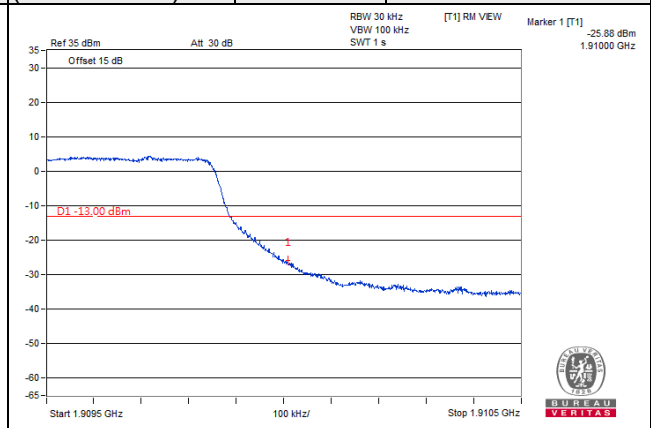

**LTE Band 2, Channel Bandwidth 5MHz**

<b>Channel 18625 (1852.50MHz)</b>	<b>QPSK</b>	<b>1 RB / 0 RB Offset</b>	<b>Channel 19175 (1907.50MHz)</b>	<b>QPSK</b>	<b>1 RB / 24 RB Offset</b>
---------------------------------------	-------------	---------------------------	---------------------------------------	-------------	----------------------------

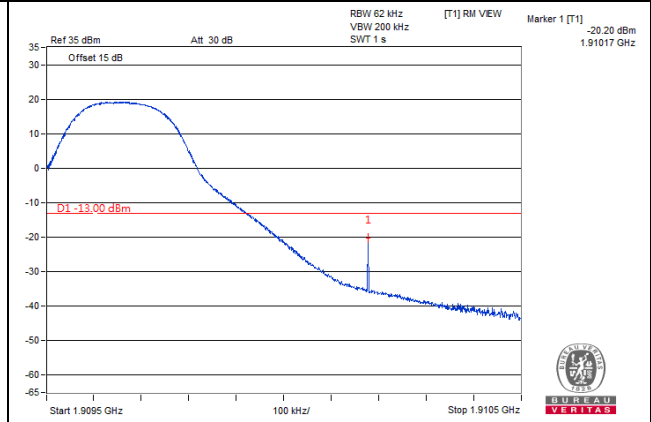
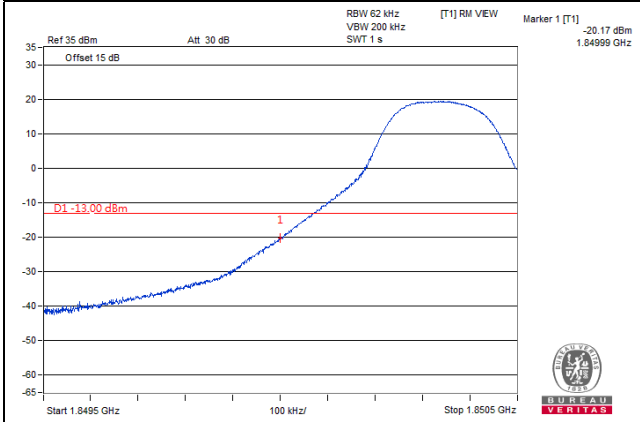

<b>Channel 18625 (1852.50MHz)</b>	<b>QPSK</b>	<b>25 RB / 0 RB Offset</b>	<b>Channel 19175 (1907.50MHz)</b>	<b>QPSK</b>	<b>25 RB / 0 RB Offset</b>
---------------------------------------	-------------	----------------------------	---------------------------------------	-------------	----------------------------

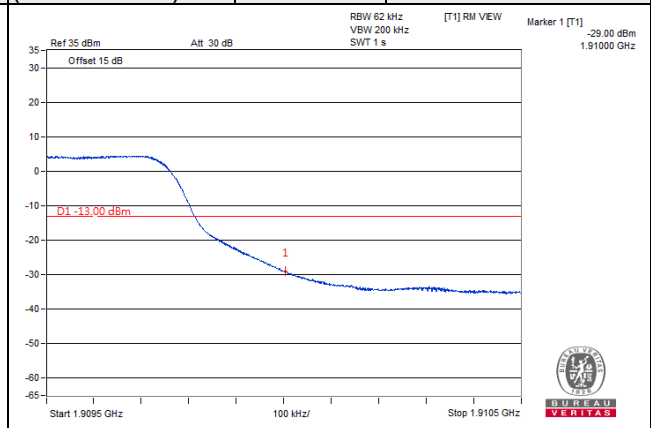
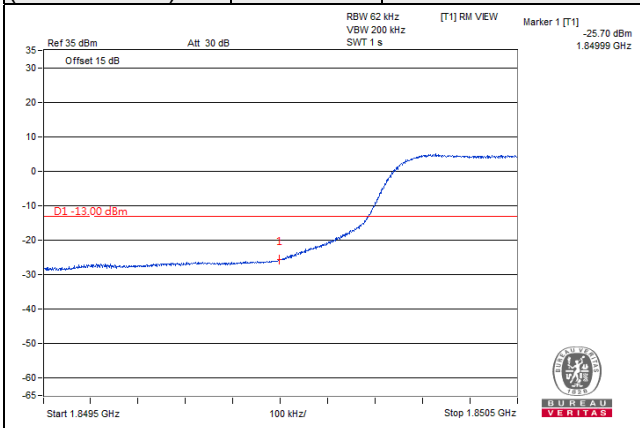

LTE Band 2, Channel Bandwidth 10MHz

Channel 18650 (1855.00MHz)	QPSK	1 RB / 0 RB Offset	Channel 19150 (1905.00MHz)	QPSK	1 RB / 49 RB Offset
-------------------------------	------	--------------------	-------------------------------	------	---------------------

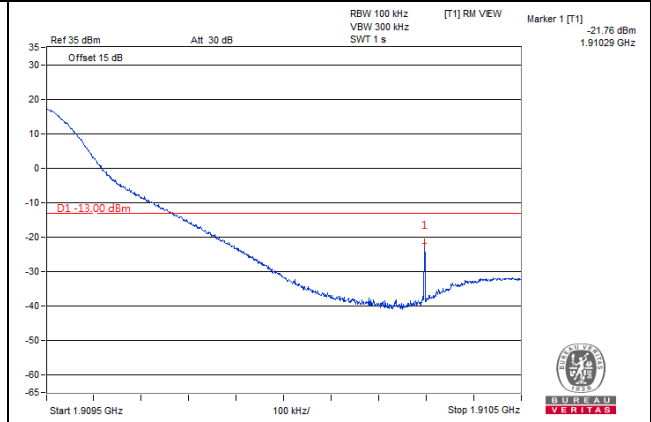
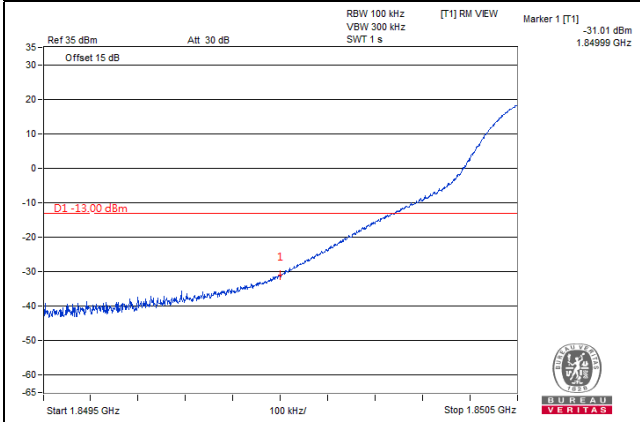

Channel 18650 (1855.00MHz)	QPSK	50 RB / 0 RB Offset	Channel 19150 (1905.00MHz)	QPSK	50 RB / 0 RB Offset
-------------------------------	------	---------------------	-------------------------------	------	---------------------

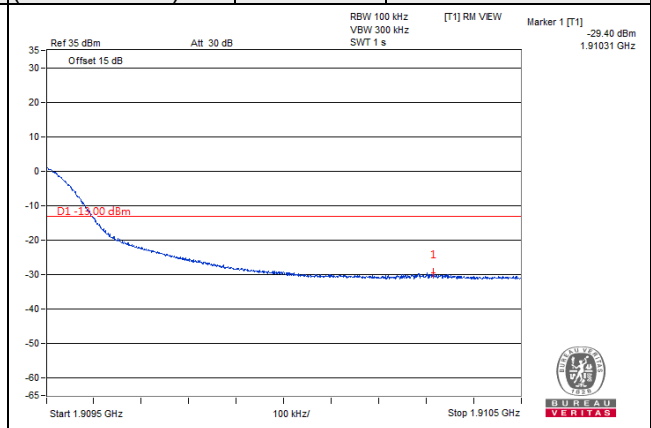
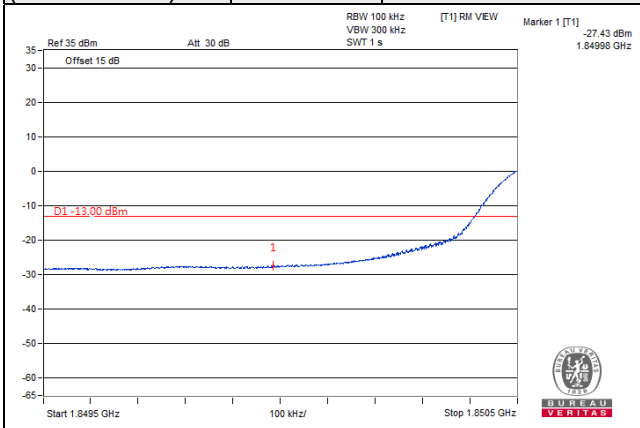

LTE Band 2, Channel Bandwidth 15MHz

Channel 18675 (1857.50MHz)	QPSK	1 RB / 0 RB Offset	Channel 19125 (1902.50MHz)	QPSK	1 RB / 74 RB Offset
-------------------------------	------	--------------------	-------------------------------	------	---------------------

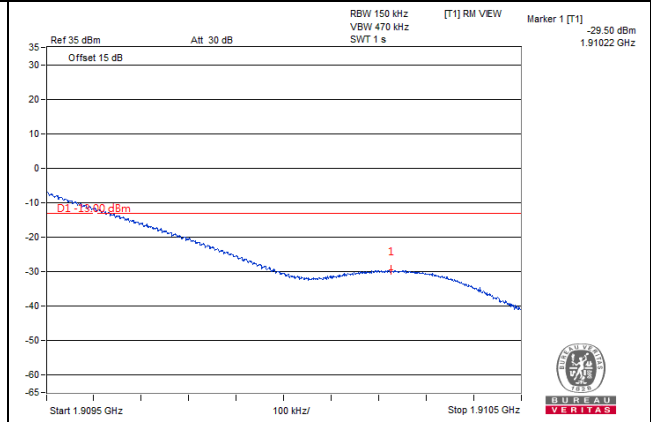
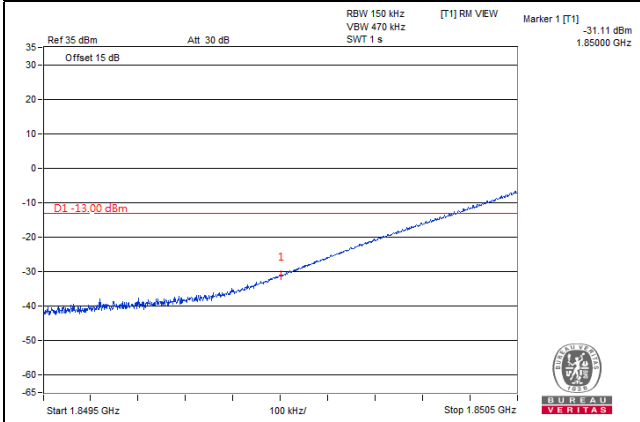

Channel 18675 (1857.50MHz)	QPSK	75 RB / 0 RB Offset	Channel 19125 (1902.50MHz)	QPSK	75 RB / 0 RB Offset
-------------------------------	------	---------------------	-------------------------------	------	---------------------

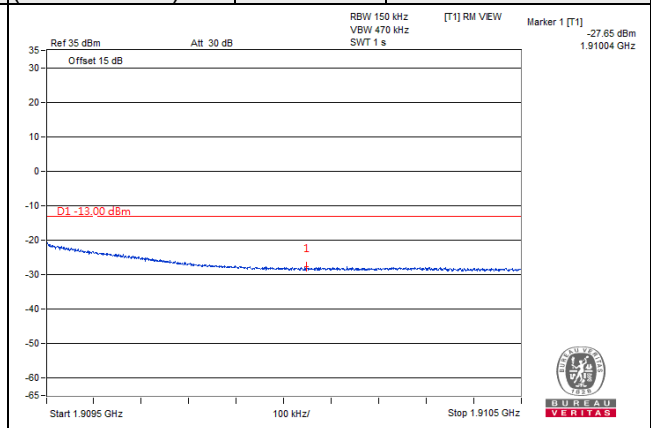
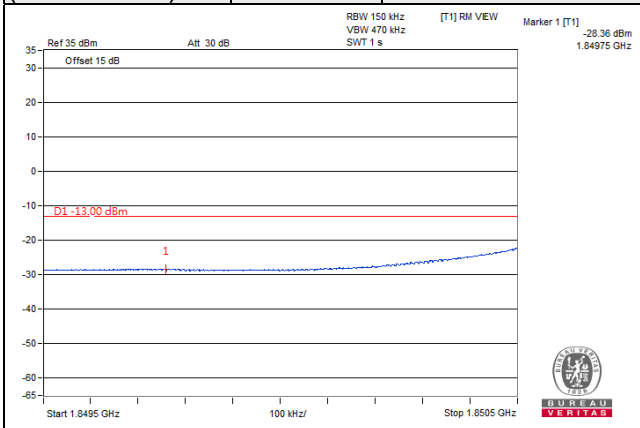

**LTE Band 2, Channel Bandwidth 20MHz**

<b>Channel 18700 (1860.00MHz)</b>	<b>QPSK</b>	<b>1 RB / 0 RB Offset</b>	<b>Channel 19100 (1900.00 MHz)</b>	<b>QPSK</b>	<b>1 RB / 99 RB Offset</b>
---------------------------------------	-------------	---------------------------	--	-------------	----------------------------

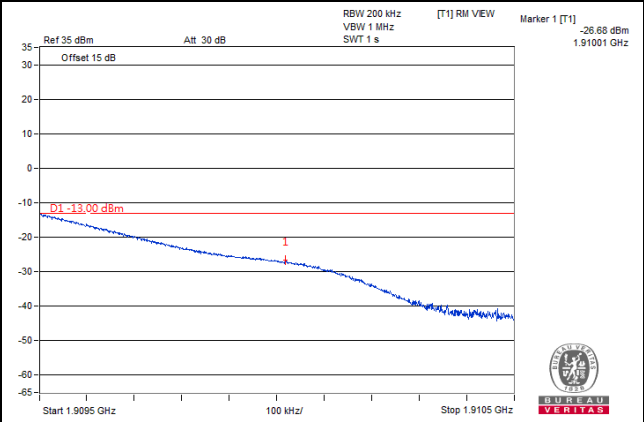
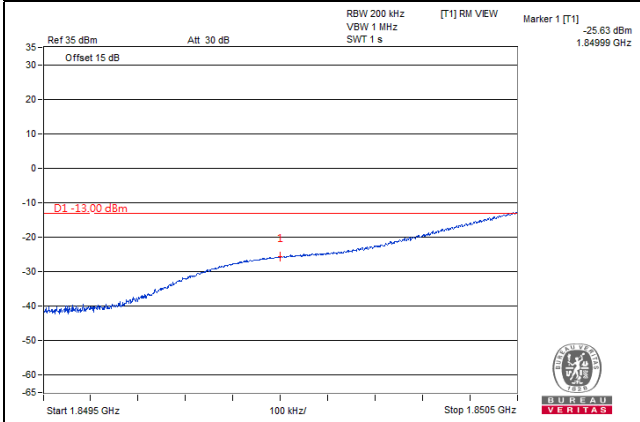

<b>Channel 18700 (1860.00MHz)</b>	<b>QPSK</b>	<b>100 RB / 0 RB Offset</b>	<b>Channel 19100 (1900.00 MHz)</b>	<b>QPSK</b>	<b>100 RB / 0 RB Offset</b>
---------------------------------------	-------------	-----------------------------	--	-------------	-----------------------------

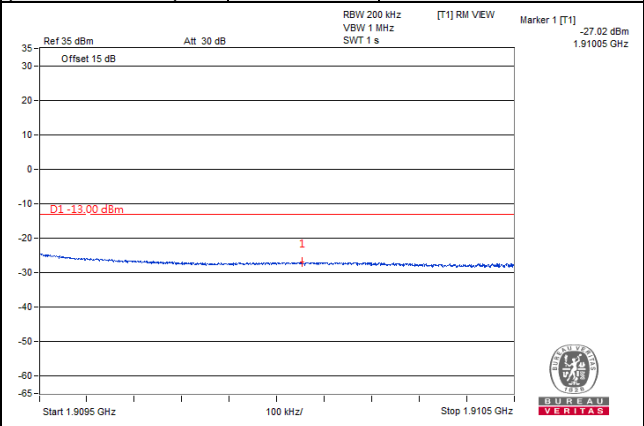
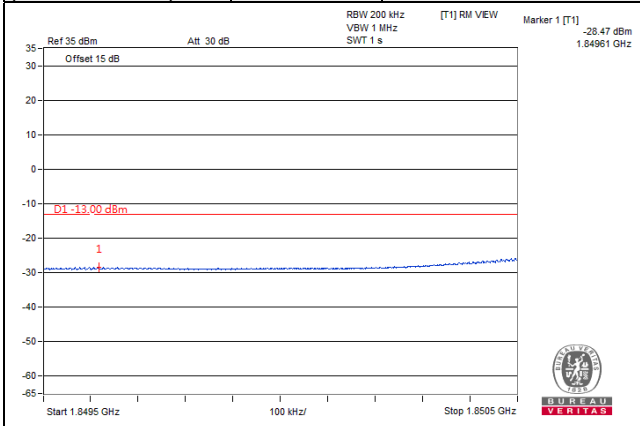

## 4.6 Peak to Average Ratio

### 4.6.1 Limits of Peak to Average Ratio Measurement

In measuring transmissions in this band using an average power technique, the peak to-average ratio (PAR) of the transmission may not exceed 13 dB

### 4.6.2 Test Setup

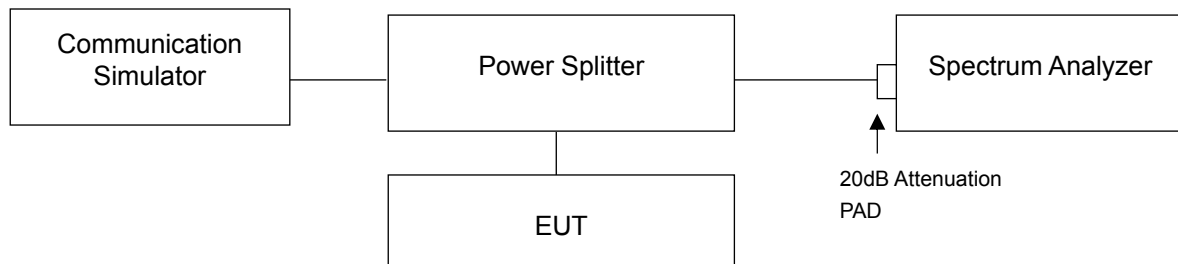

### 4.6.3 Test Procedures

- Set resolution/measurement bandwidth  $\geq$  signal's occupied bandwidth;
- Set the number of counts to a value that stabilizes the measured CCDF curve;
- Record the maximum PAPR level associated with a probability of 0.1%.



#### 4.6.4 Test Results

##### GSM

Channel	Frequency (MHz)	Peak To Average Ratio (dB)		
		GSM	GPRS	EDGE
512	1850.2	2.90	2.90	2.90
661	1880.0	2.90	2.90	2.91
810	1909.8	2.91	2.91	2.90

#### Spectrum Plot of Worst Value



WCDMA Band 5

Channel	Frequency (MHz)	Peak To Average Ratio (dB)		
		WCDMA	HSDPA	HSUPA
9262	1852.4	3.53	3.59	3.65
9400	1880.0	2.91	2.90	2.90
9538	1907.6	2.81	2.83	2.84

Spectrum Plot of Worst Value

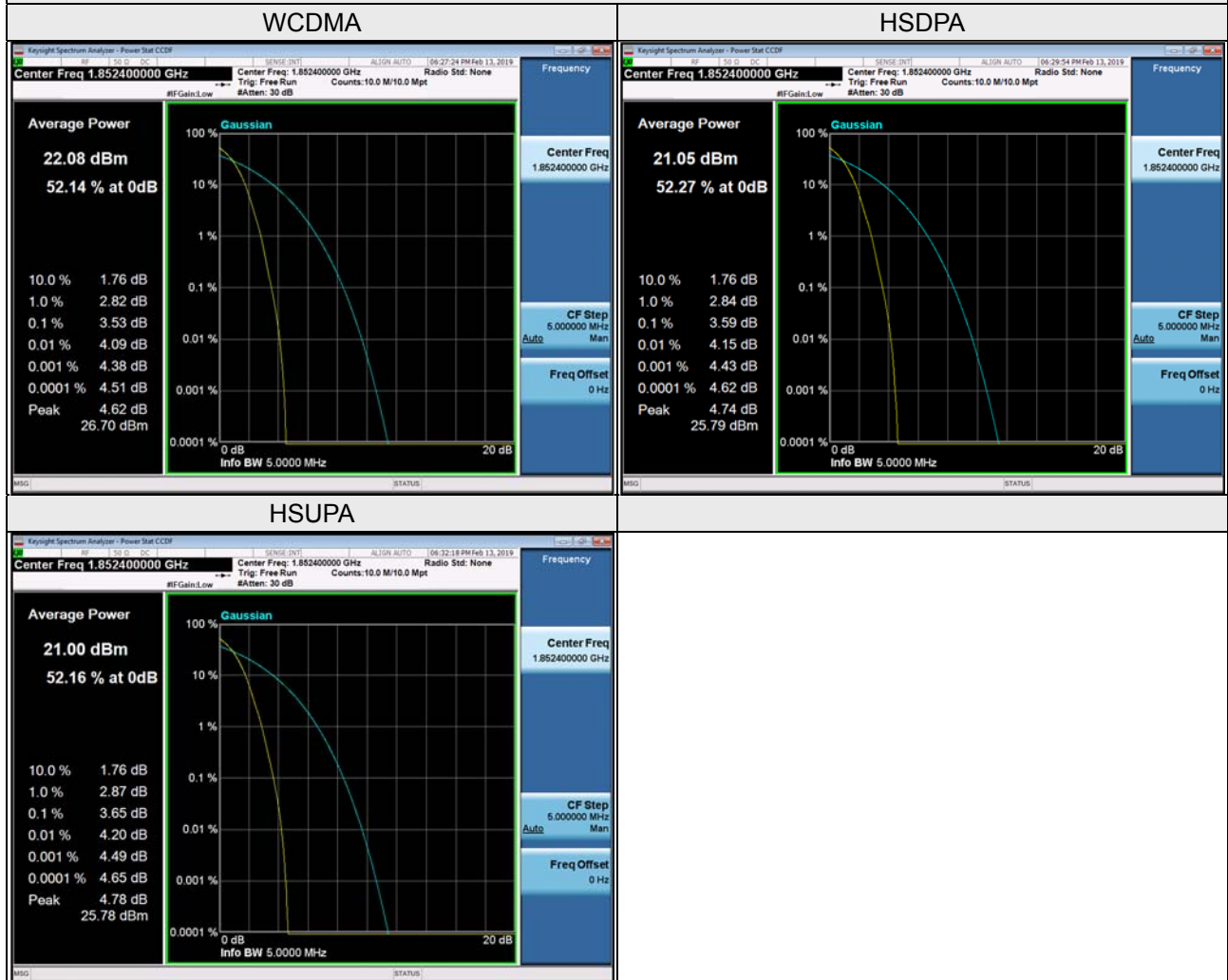

LTE Band 2

LTE Band 2, Channel Bandwidth 1.4MHz				
Channel	Frequency (MHz)	Peak To Average Ratio (dB)		
		QPSK	16QAM	64QAM
18607	1850.7	4.17	5.76	5.74
18900	1880.0	3.70	5.10	5.07
19193	1909.3	3.64	4.93	4.90
LTE Band 2, Channel Bandwidth 3MHz				
Channel	Frequency (MHz)	Peak To Average Ratio (dB)		
		QPSK	16QAM	64QAM
18615	1851.5	5.76	5.59	5.56
18900	1880.0	3.49	4.99	4.99
19185	1908.5	3.51	4.88	4.79
LTE Band 2, Channel Bandwidth 5MHz				
Channel	Frequency (MHz)	Peak To Average Ratio (dB)		
		QPSK	16QAM	64QAM
18625	1852.5	3.90	5.58	5.55
18900	1880.0	3.54	4.97	4.96
19175	1907.5	3.71	5.08	4.97
LTE Band 2, Channel Bandwidth 10MHz				
Channel	Frequency (MHz)	Peak To Average Ratio (dB)		
		QPSK	16QAM	64QAM
18650	1855.0	3.95	5.74	5.57
18900	1880.0	3.67	5.08	5.08
19150	1905.0	3.95	5.47	5.38
LTE Band 2, Channel Bandwidth 15MHz				
Channel	Frequency (MHz)	Peak To Average Ratio (dB)		
		QPSK	16QAM	64QAM
18675	1857.5	3.85	5.55	5.43
18900	1880.0	3.68	5.05	5.04
19125	1902.5	3.87	5.60	5.55

LTE Band 2, Channel Bandwidth 20MHz

Channel	Frequency (MHz)	Peak To Average Ratio (dB)		
		QPSK	16QAM	64QAM
18700	1860.0	3.86	5.54	5.50
18900	1880.0	3.78	5.19	5.03
19100	1900.0	3.79	5.55	5.51

### Spectrum Plot of Worst Value

1.4MHz / 16QAM

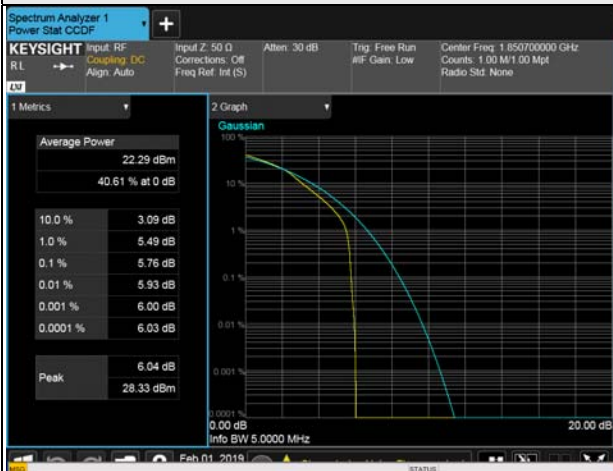

3MHz / QPSK

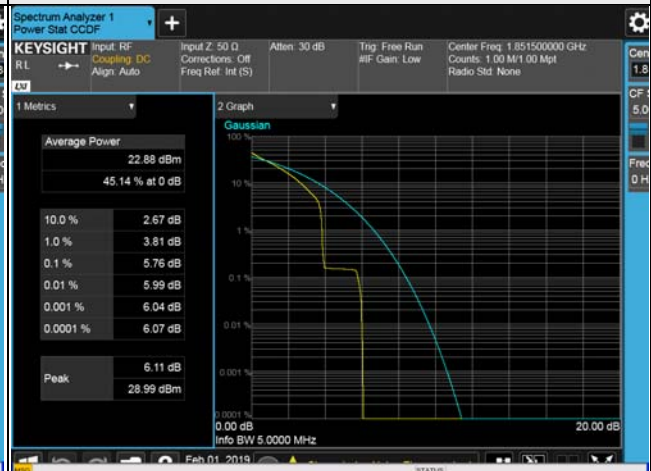

5MHz / 16QAM

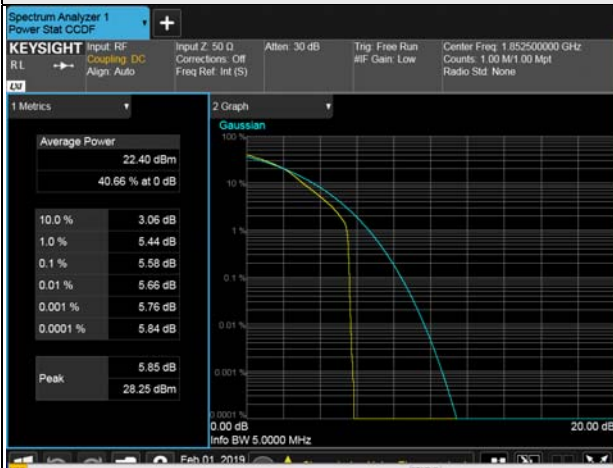

10MHz / 16QAM

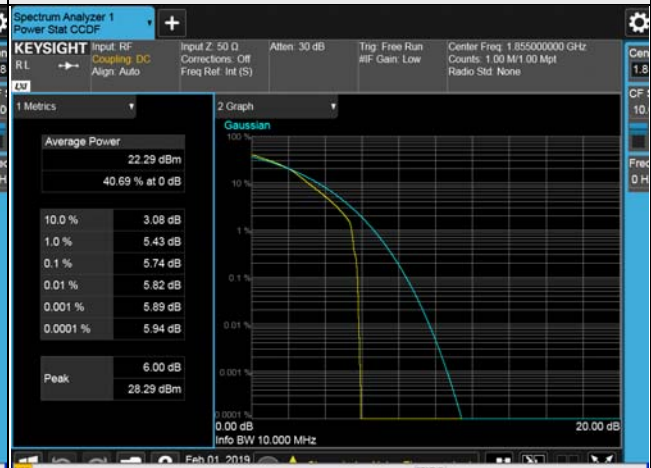

15MHz / 16QAM

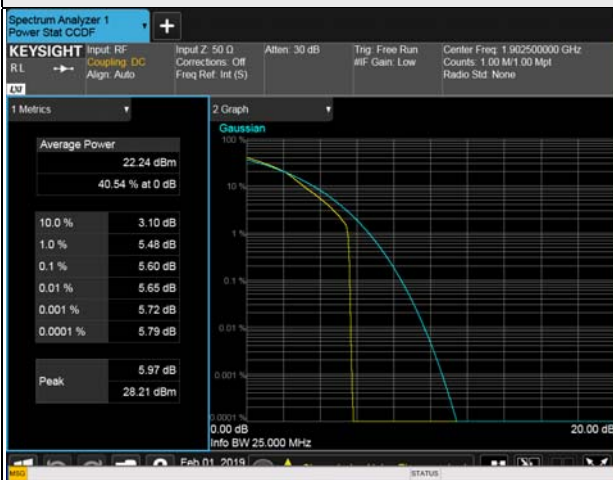

20MHz / 16QAM



## 4.7 Conducted Spurious Emissions

### 4.7.1 Limits of Conducted Spurious Emissions Measurement

The power of any emission outside of the authorized operating frequency ranges must be attenuated below the transmitting power (P) by a factor of at least  $43 + 10 \log(P)$  dB. The emission limit equal to  $-13\text{dBm}$ .

### 4.7.2 Test Setup

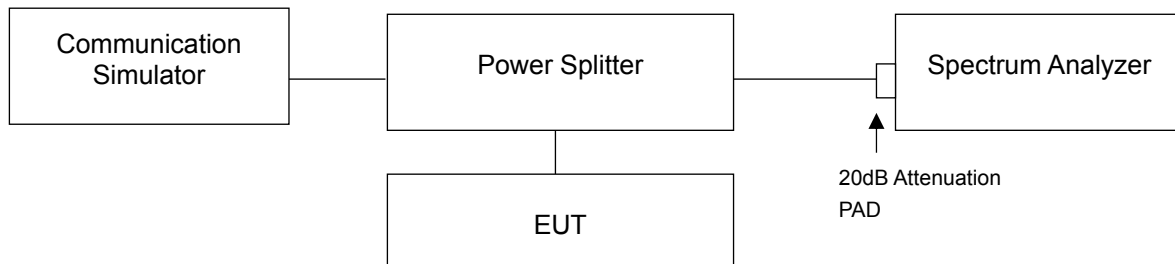

### 4.7.3 Test Procedure

- The EUT makes a phone call to the communication simulator. All measurements were done at low, middle and high operational frequency range.
- Measuring frequency range is from 9 kHz to 1GHz. 20dB attenuation pad is connected with spectrum. RBW=100kHz and VBW=300kHz is used for conducted emission measurement.
- Measuring frequency range is from 1GHz to 26.5GHz or 27GHz. 20dB attenuation pad is connected with spectrum. RBW=1MHz and VBW=3MHz is used for conducted emission measurement.
- Spectrum RBW settings are referenced to ANSI 63.2-1996 section 8.2.2.

### 4.7.4 Test Results



**GSM**

**Channel 661 (1880.0MHz)**

**Frequency Range : 9kHz~1GHz**

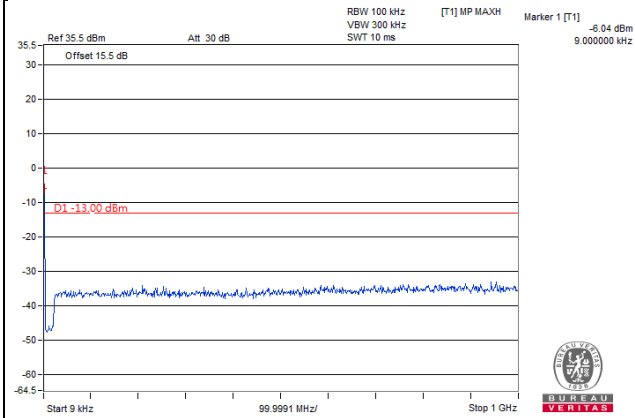

**Frequency Range : 1GHz~10GHz**

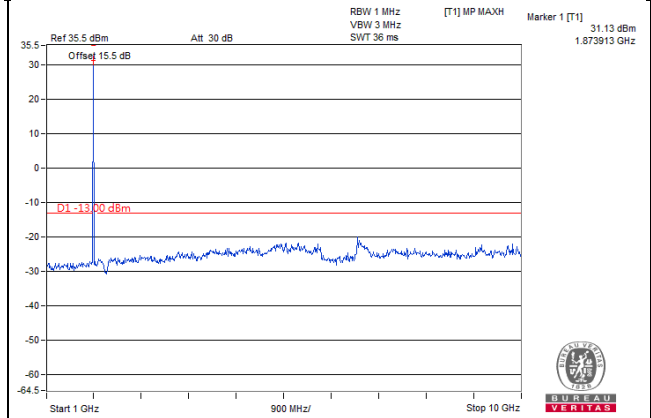

**Frequency Range : 10GHz~26.5GHz**

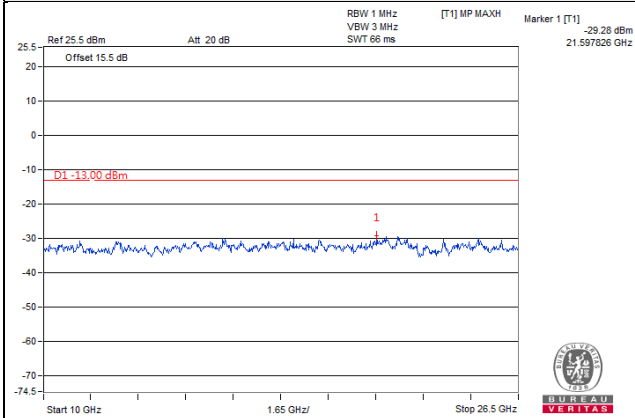

\*The 9kHz signal over the limit is from Spectrum.



**GSM**

**Channel 810 (1909.8MHz)**

**Frequency Range : 9kHz~1GHz**

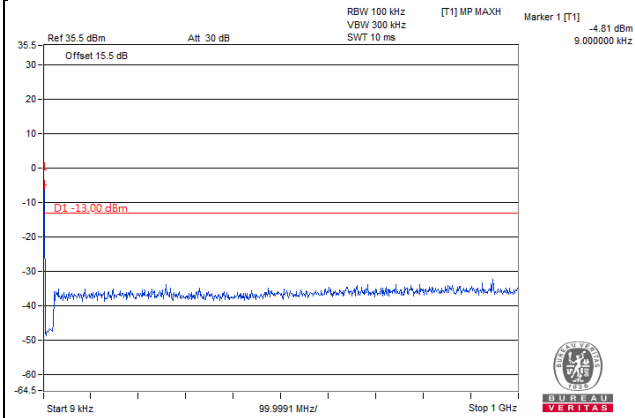

**Frequency Range : 1GHz~10GHz**

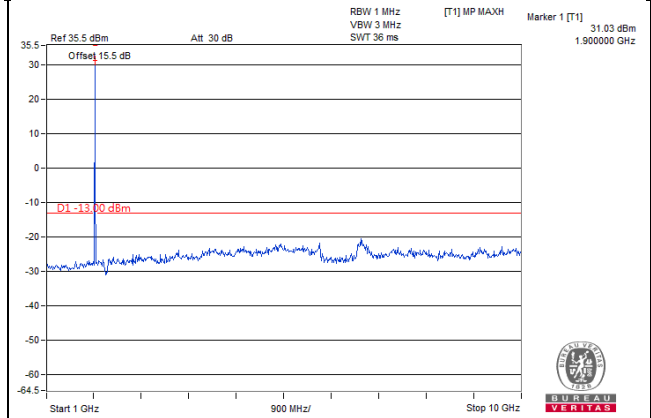

**Frequency Range : 10GHz~26.5GHz**

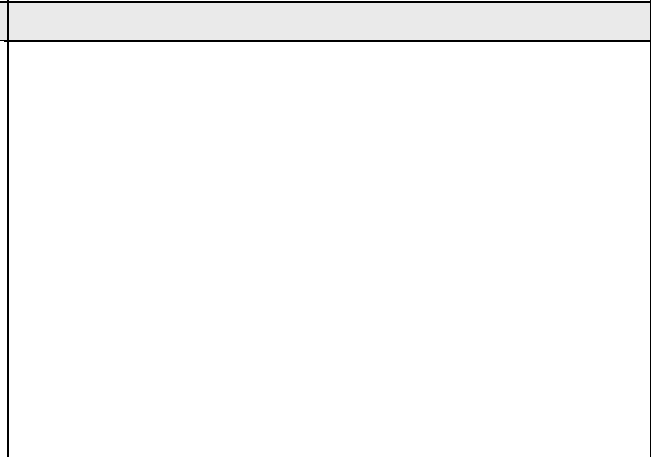
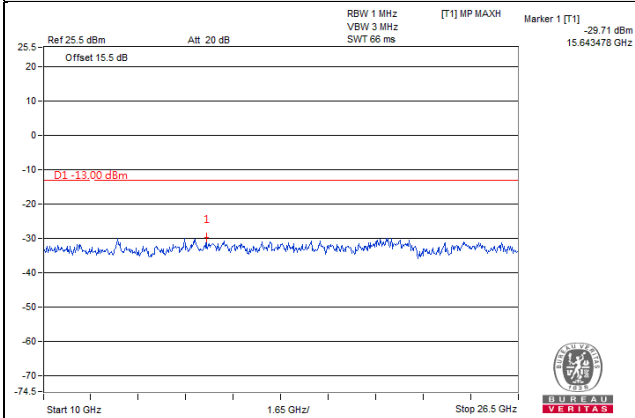

\*The 9kHz signal over the limit is from Spectrum.

**GPRS**

**Channel 512 (1850.2MHz)**

**Frequency Range : 9kHz~1GHz**

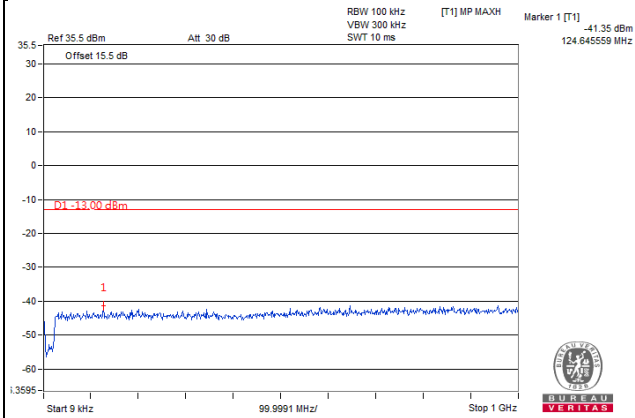

**Frequency Range : 1GHz~10GHz**

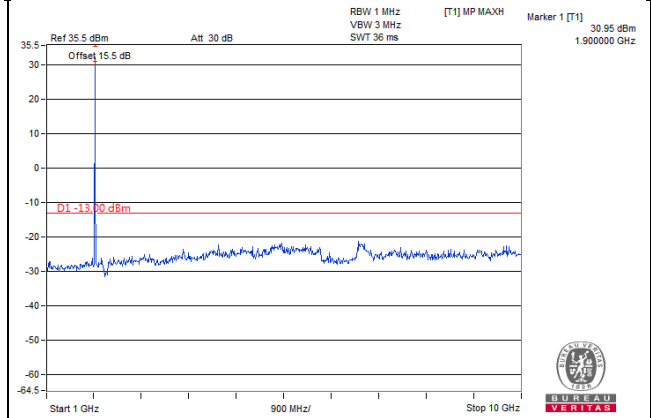

**Frequency Range : 10GHz~26.5GHz**

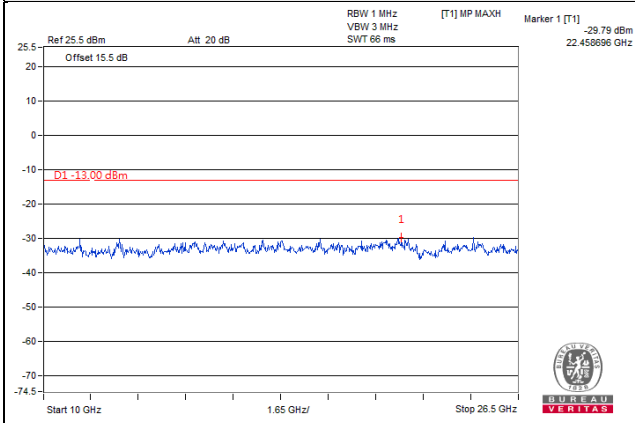

**GPRS**

**Channel 661 (1880.0MHz)**

**Frequency Range : 9kHz~1GHz**

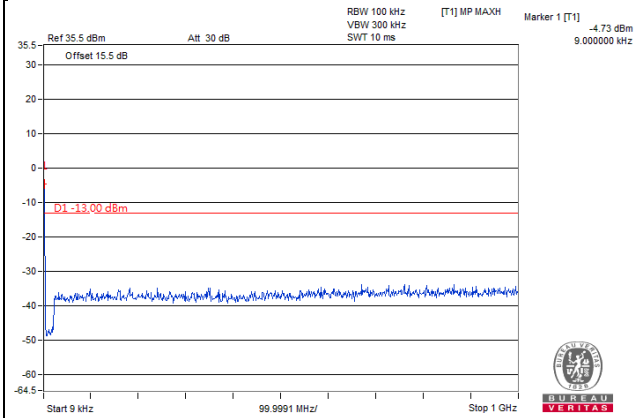

**Frequency Range : 1GHz~10GHz**

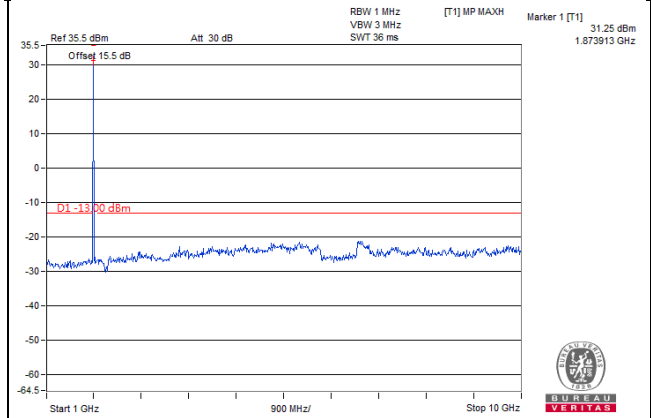

**Frequency Range : 10GHz~26.5GHz**

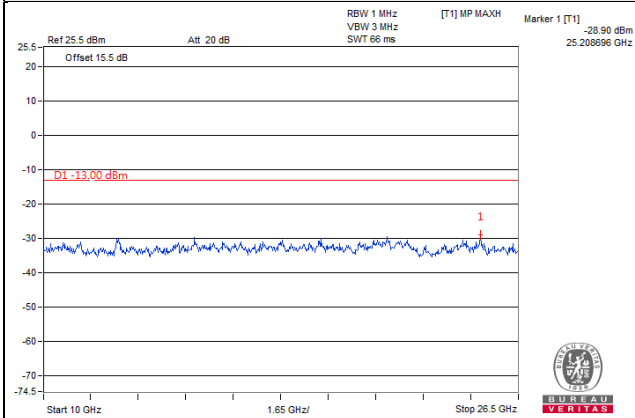

\*The 9kHz signal over the limit is from Spectrum.

**GPRS**

**Channel 810 (1909.8MHz)**

**Frequency Range : 9kHz~1GHz**

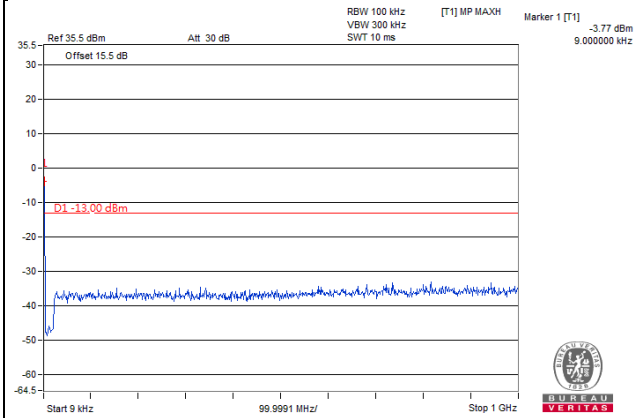

**Frequency Range : 1GHz~10GHz**

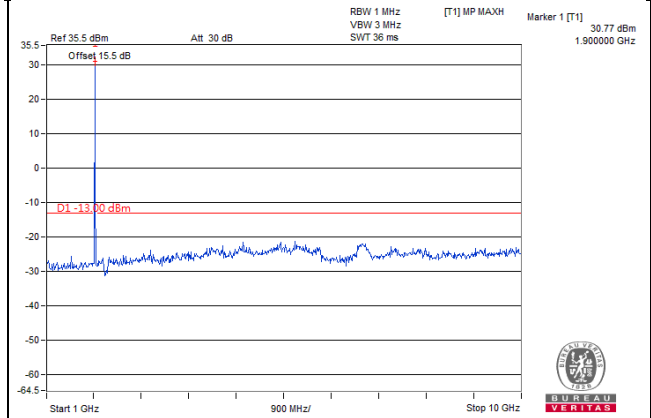

**Frequency Range : 10GHz~26.5GHz**

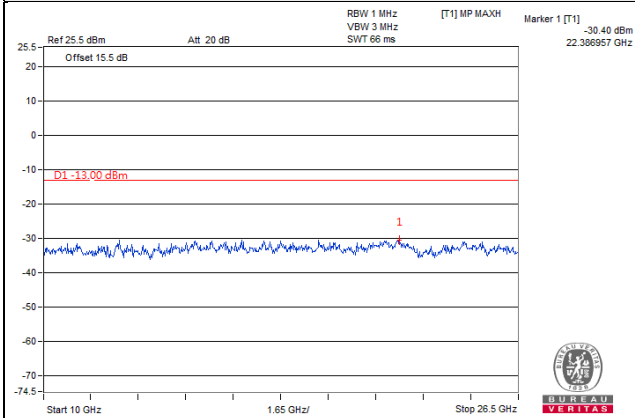

\*The 9kHz signal over the limit is from Spectrum.

**EDGE**

**Channel 512 (1850.2MHz)**

**Frequency Range : 9kHz~1GHz**

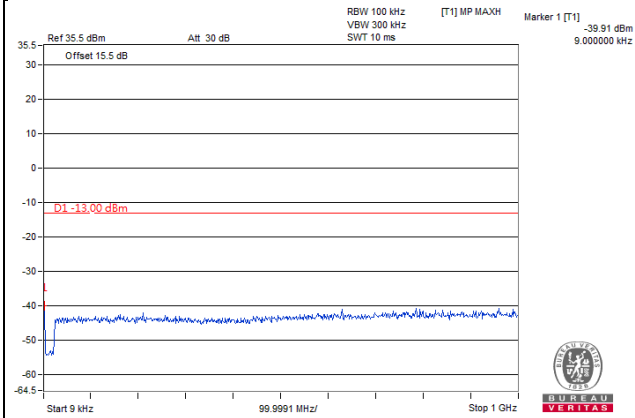

**Frequency Range : 1GHz~10GHz**

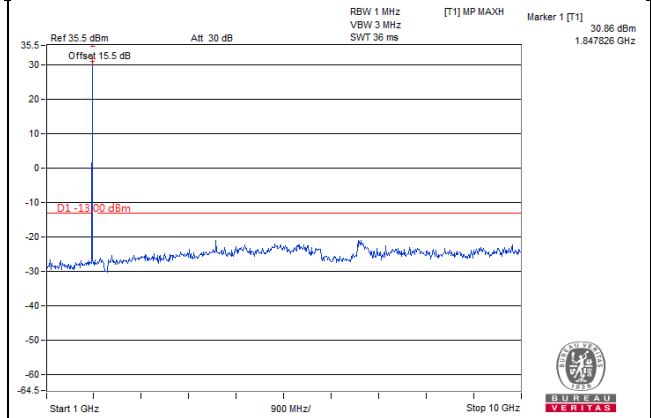

**Frequency Range : 10GHz~26.5GHz**

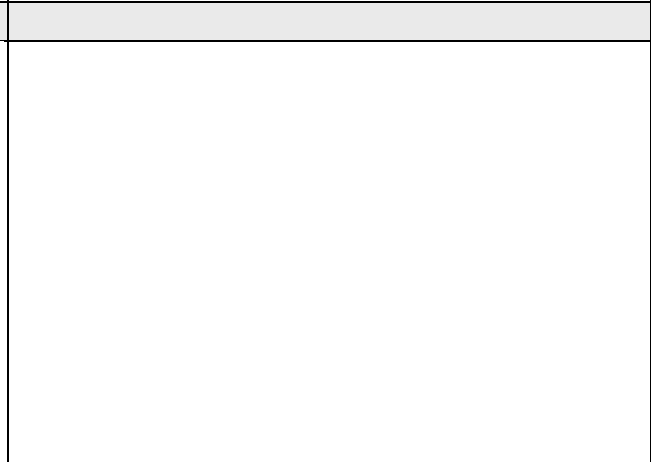
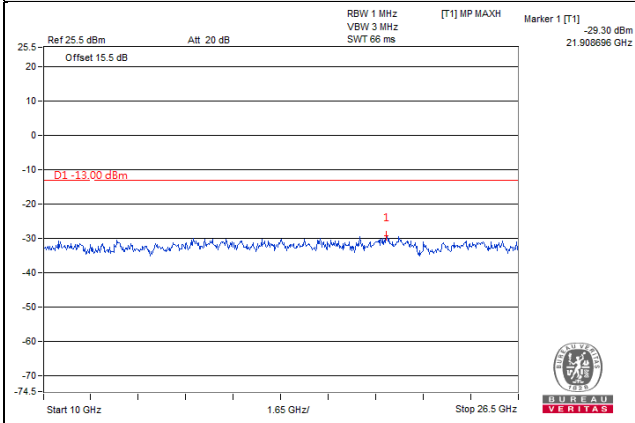

**EDGE**

**Channel 661 (1880.0MHz)**

**Frequency Range : 9kHz~1GHz**

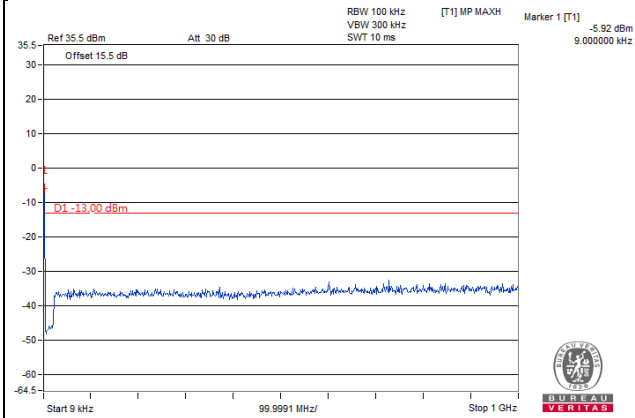

**Frequency Range : 1GHz~10GHz**

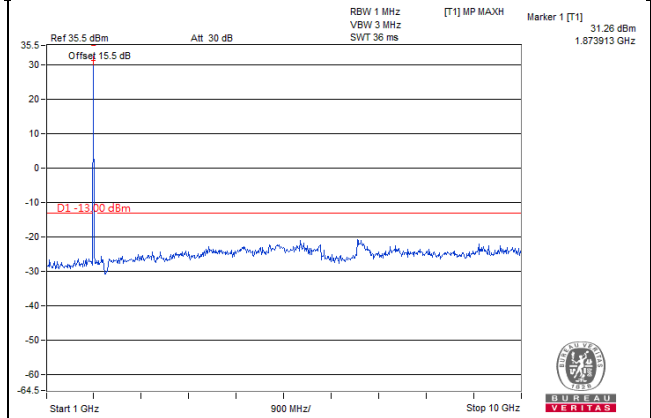

**Frequency Range : 10GHz~26.5GHz**

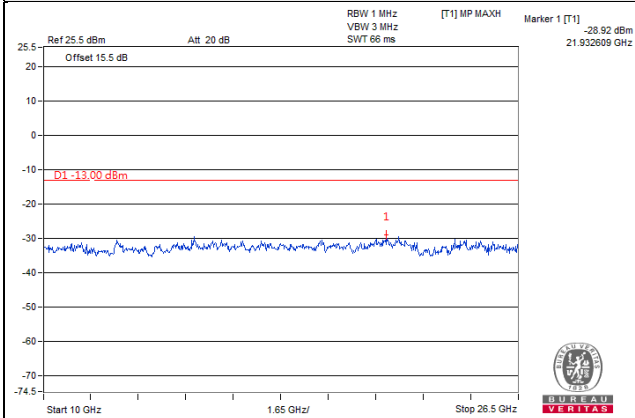

\*The 9kHz signal over the limit is from Spectrum.

**EDGE**

**Channel 810 (1909.8MHz)**

**Frequency Range : 9kHz~1GHz**

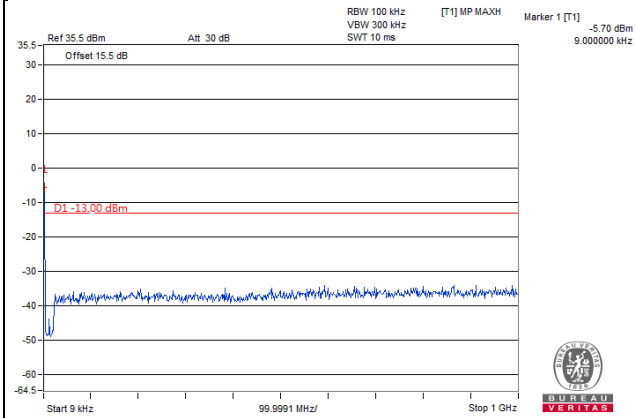

**Frequency Range : 1GHz~10GHz**

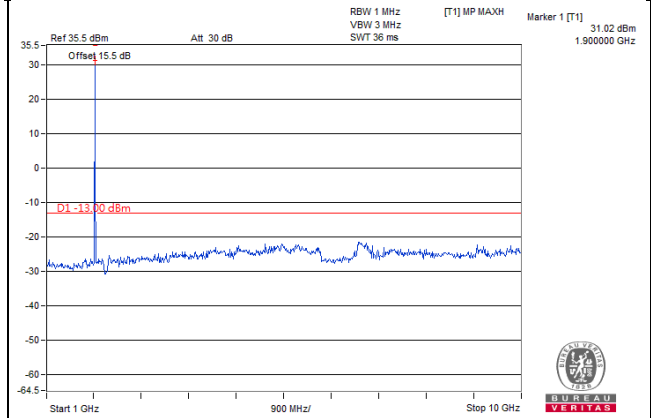

**Frequency Range : 10GHz~26.5GHz**

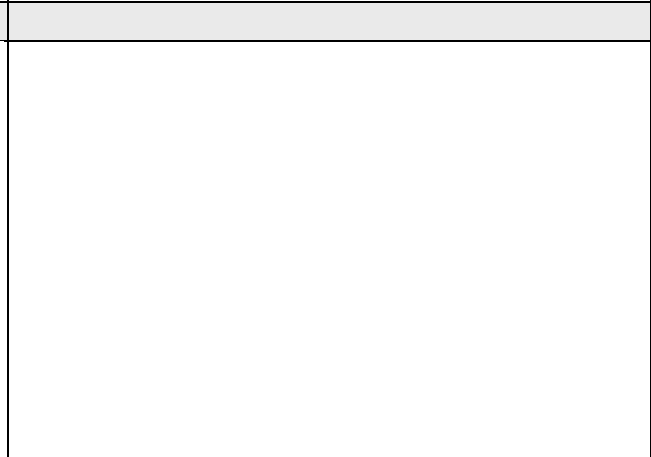
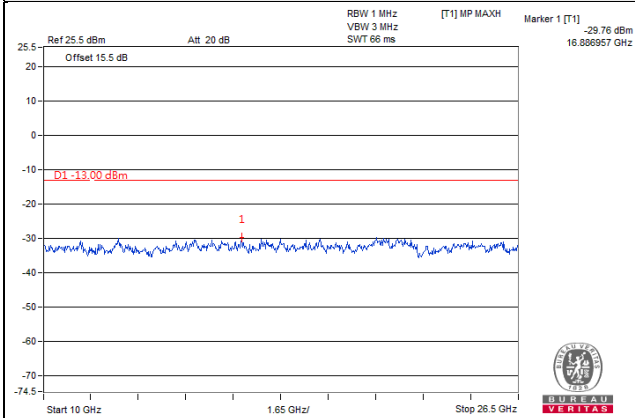

\*The 9kHz signal over the limit is from Spectrum.

WCDMA

Channel 9262 (1852.4MHz)

Frequency Range : 9kHz~1GHz

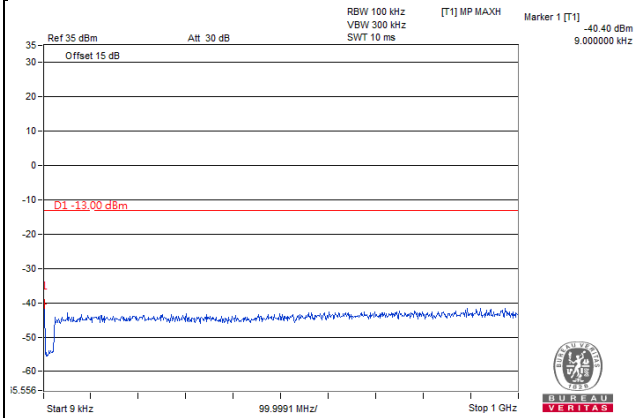

Frequency Range : 1GHz~10GHz

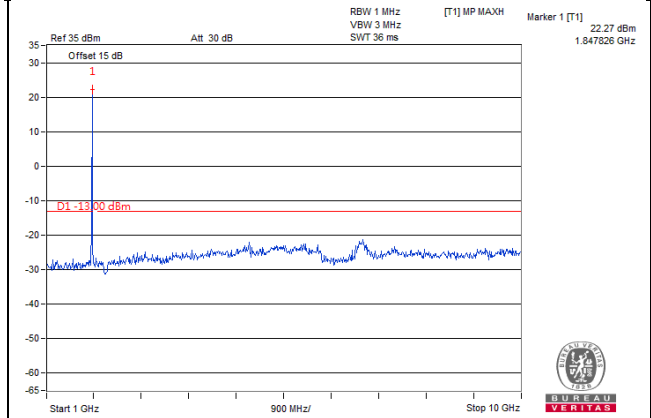

Frequency Range : 10GHz~26.5GHz

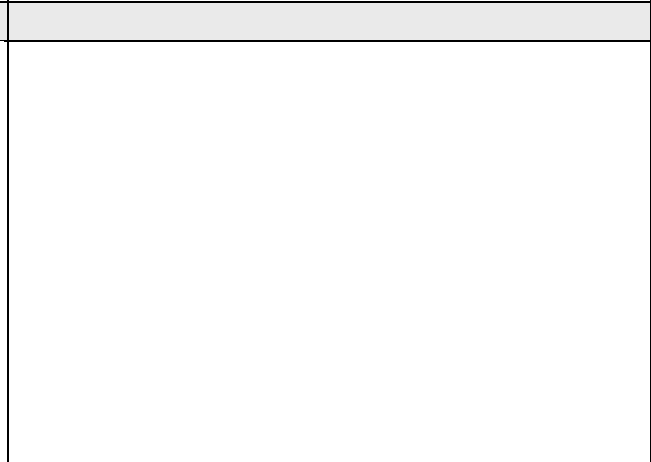
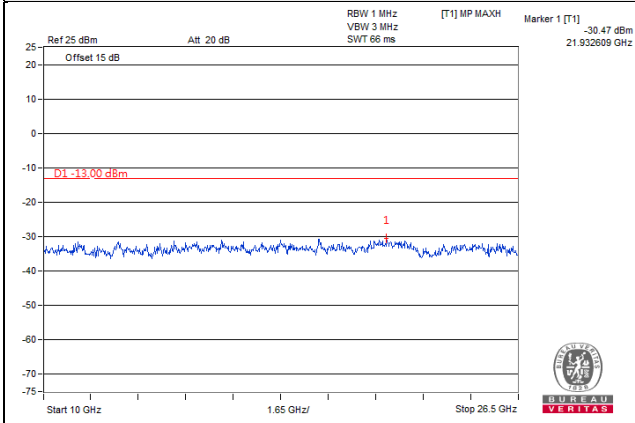



WCDMA

Channel 9400 (1880.0MHz)

Frequency Range : 9kHz~1GHz

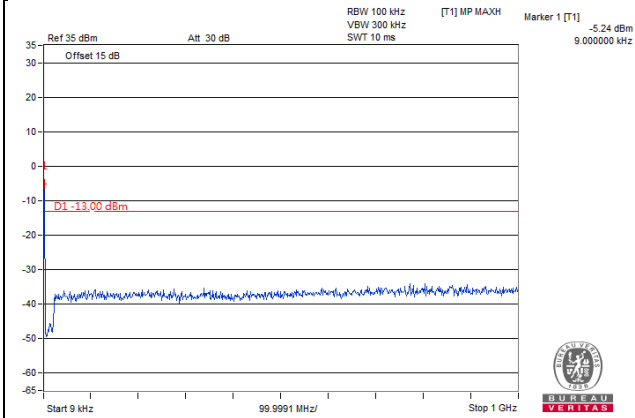

Frequency Range : 1GHz~10GHz

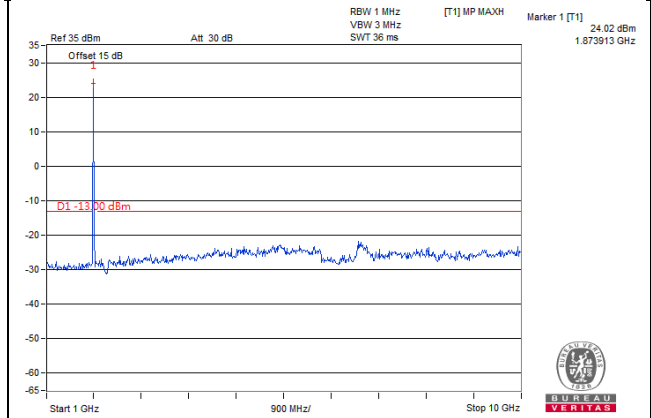

Frequency Range : 10GHz~26.5GHz

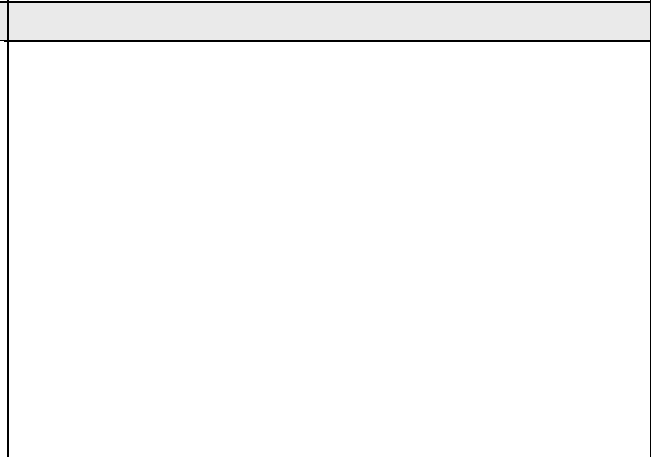
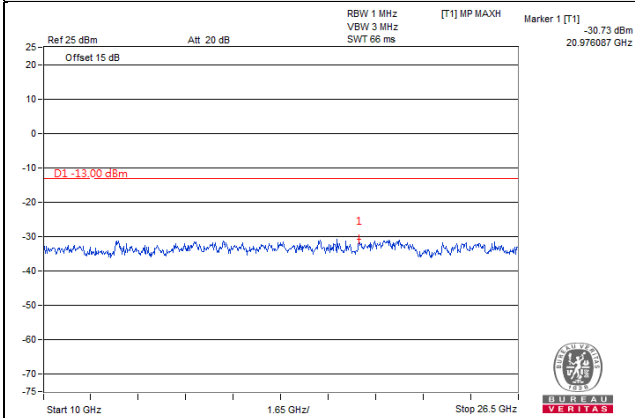

\*The 9kHz signal over the limit is from Spectrum.

WCDMA

Channel 9538 (1907.6MHz)

Frequency Range : 9kHz~1GHz

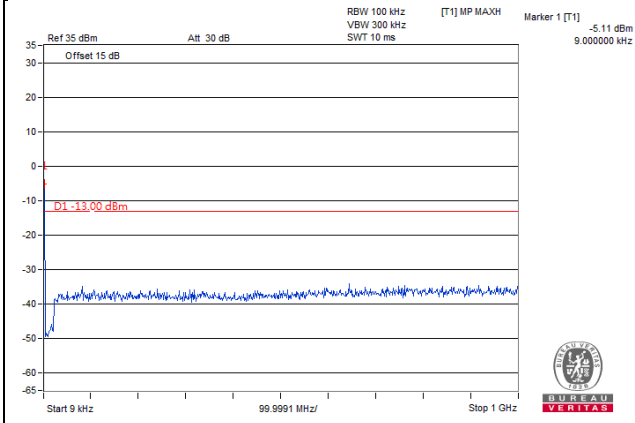

Frequency Range : 1GHz~10GHz

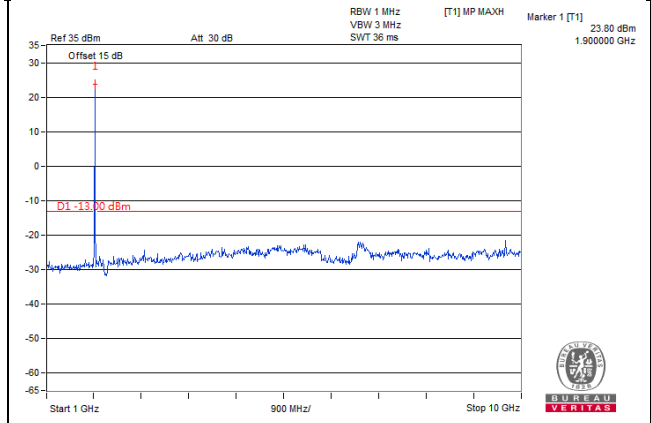

Frequency Range : 10GHz~26.5GHz

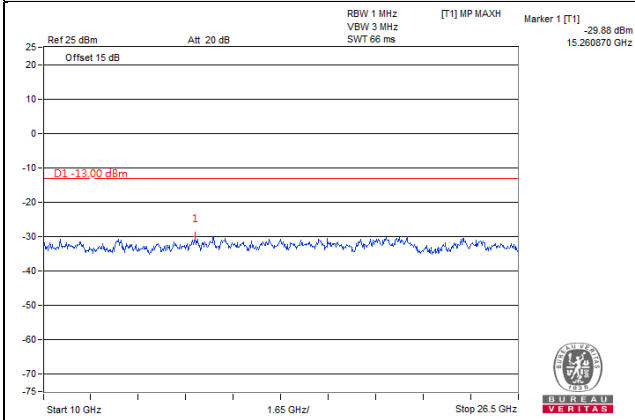

\*The 9kHz signal over the limit is from Spectrum.

# HSDPA

Channel 9262 (1852.4MHz)

Frequency Range : 9kHz~1GHz

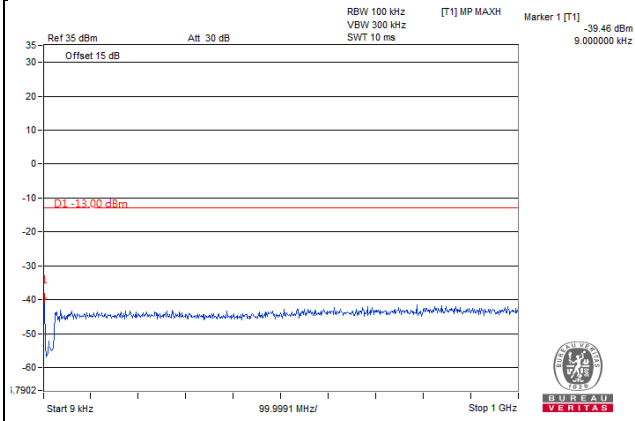

Frequency Range : 1GHz~10GHz

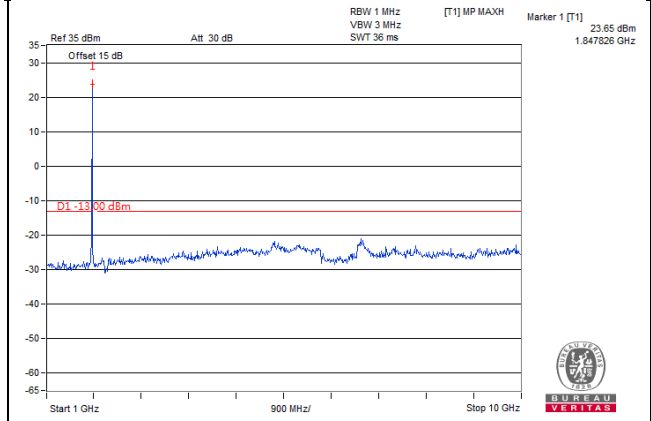

Frequency Range : 10GHz~26.5GHz

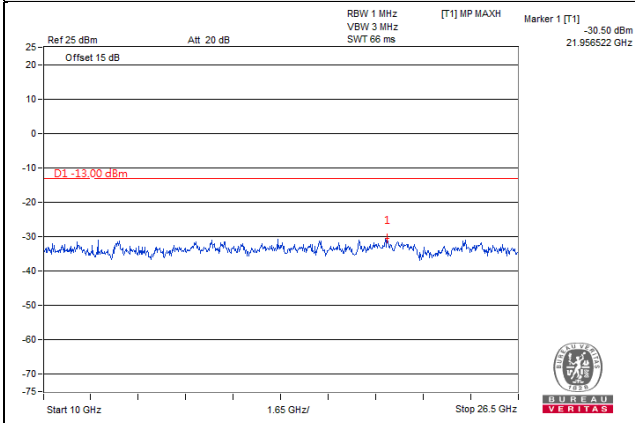

### HSDPA

Channel 9400 (1880.0MHz)

Frequency Range : 9kHz~1GHz

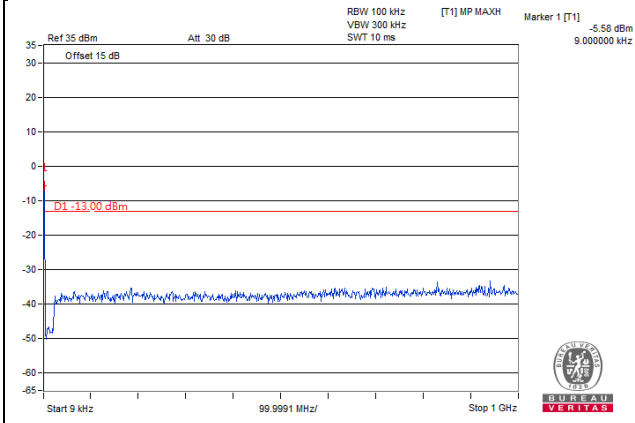

Frequency Range : 1GHz~10GHz

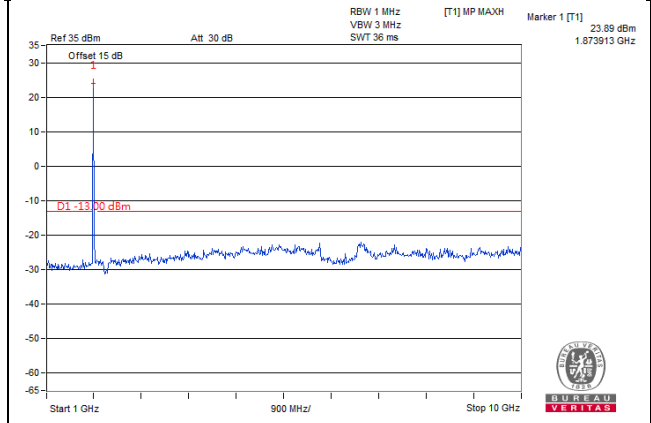

Frequency Range : 10GHz~26.5GHz

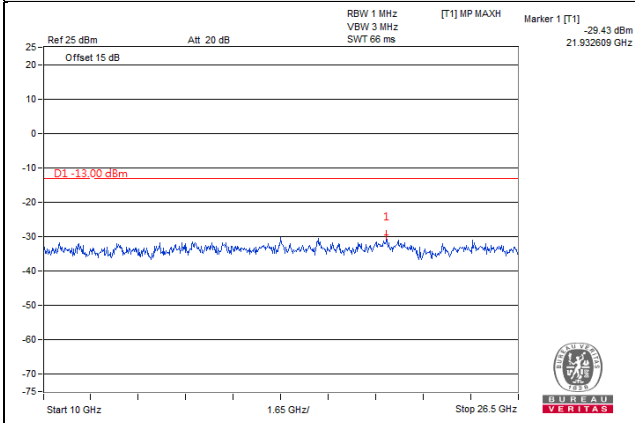

\*The 9kHz signal over the limit is from Spectrum.

HSDPA

Channel 9538 (1907.6MHz)

Frequency Range : 9kHz~1GHz

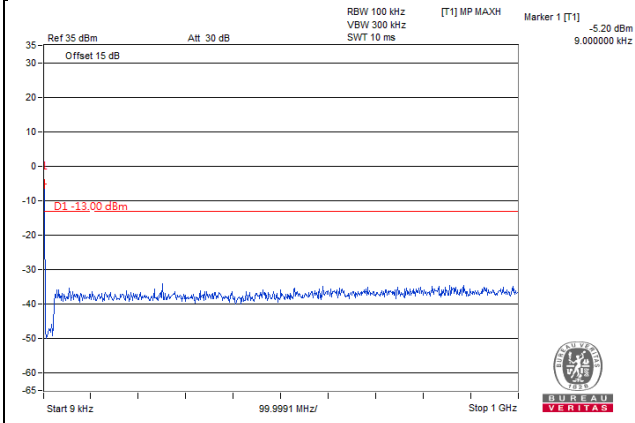

Frequency Range : 1GHz~10GHz

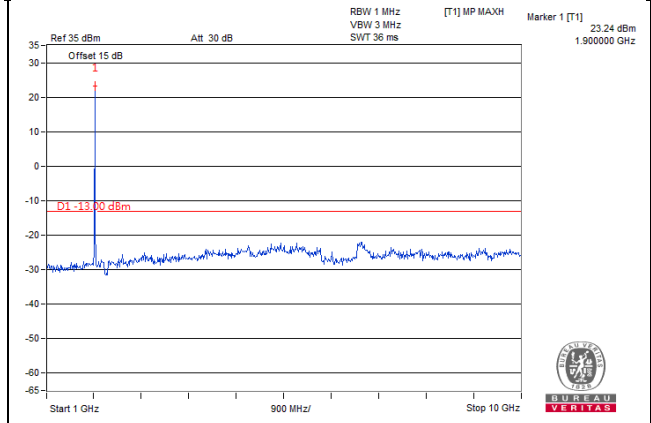

Frequency Range : 10GHz~26.5GHz

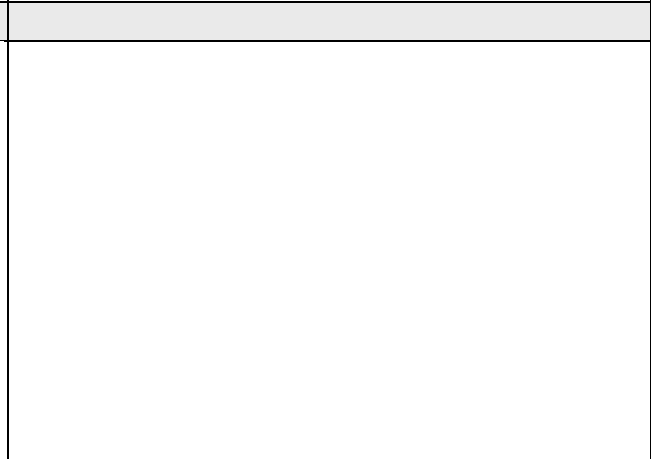
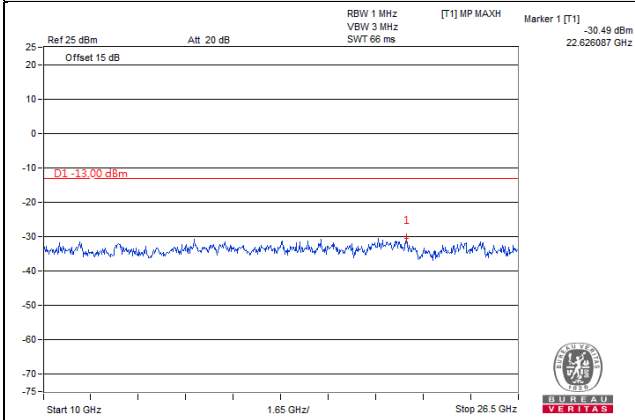

\*The 9kHz signal over the limit is from Spectrum.

# HSUPA

Channel 9262 (1852.4MHz)

Frequency Range : 9kHz~1GHz

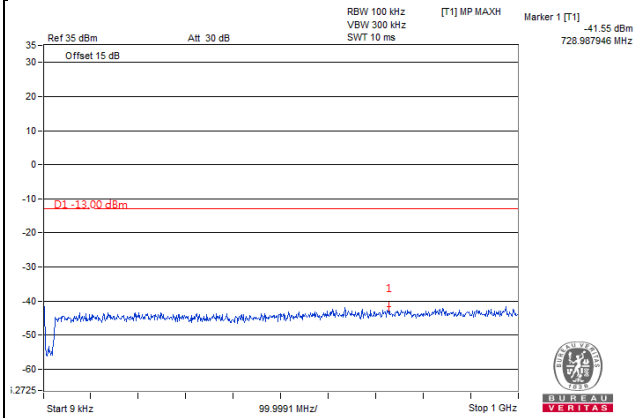

Frequency Range : 1GHz~10GHz

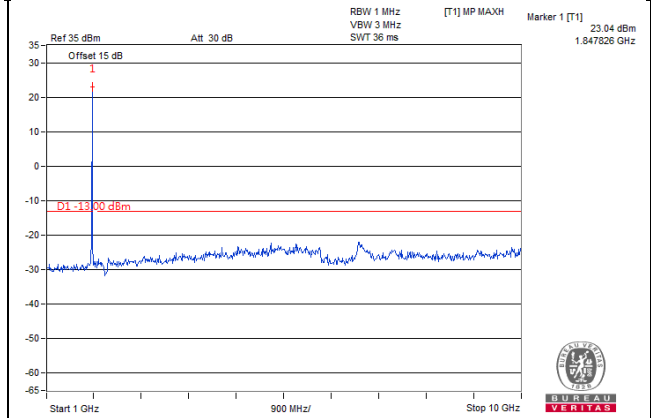

Frequency Range : 10GHz~26.5GHz

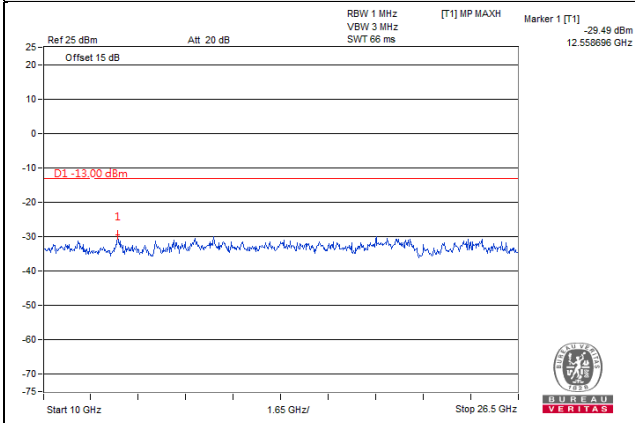

**HSUPA**

Channel 9400 (1880.0MHz)

Frequency Range : 9kHz~1GHz

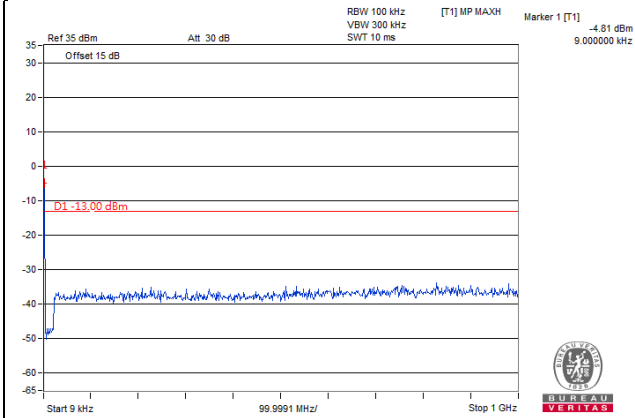

Frequency Range : 1GHz~10GHz

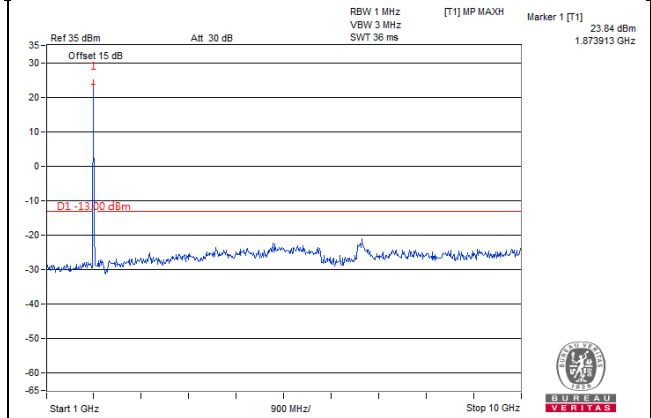

Frequency Range : 10GHz~26.5GHz

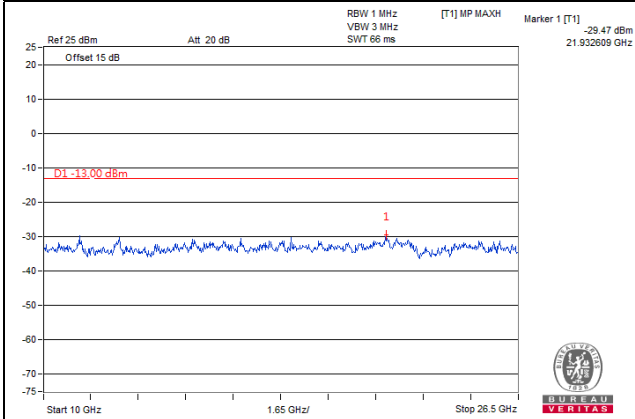

\*The 9kHz signal over the limit is from Spectrum.

**HSUPA**

**Channel 9538 (1907.6MHz)**

**Frequency Range : 9kHz~1GHz**

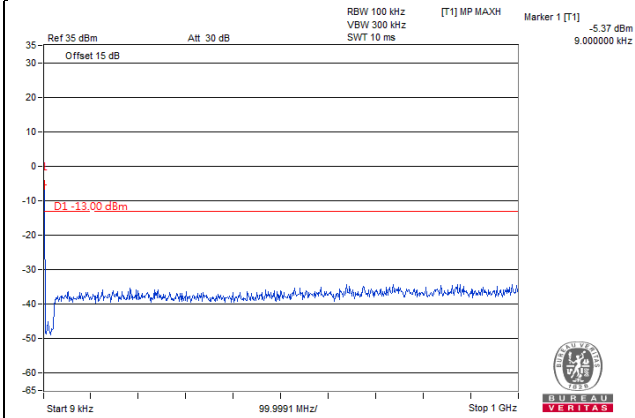

**Frequency Range : 1GHz~10GHz**

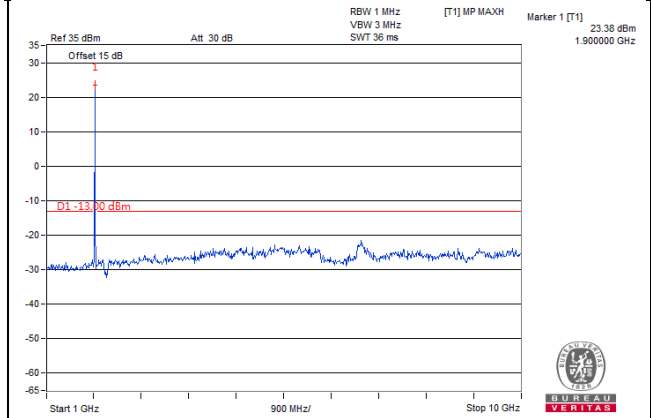

**Frequency Range : 10GHz~26.5GHz**

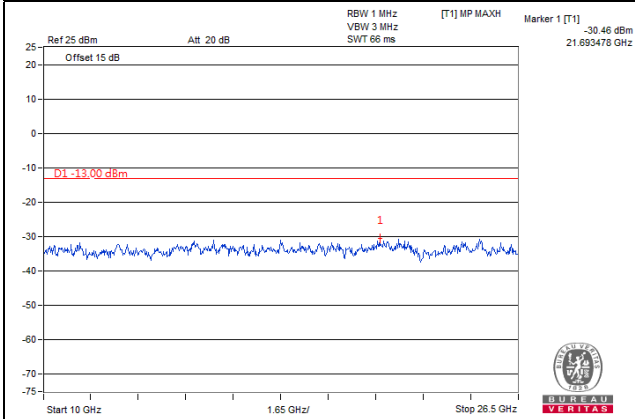

\*The 9kHz signal over the limit is from Spectrum.



LTE Band 2, Channel Bandwidth 1.4MHz

Channel 18607 (1850.70MHz)

Frequency Range : 9kHz~1GHz

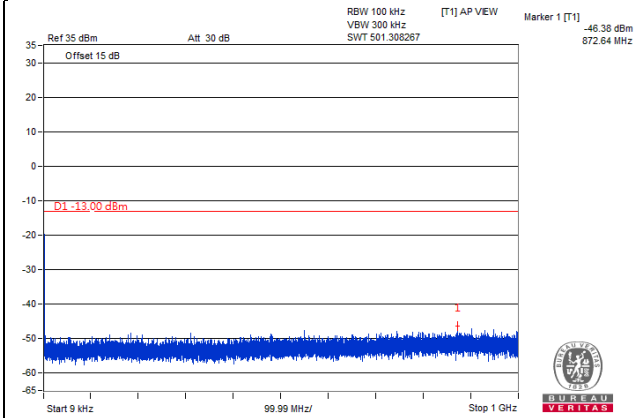

Frequency Range : 1GHz~10GHz

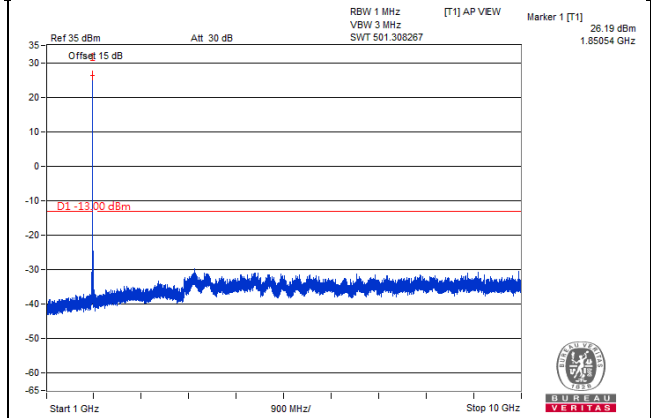

Frequency Range : 10GHz~27GHz

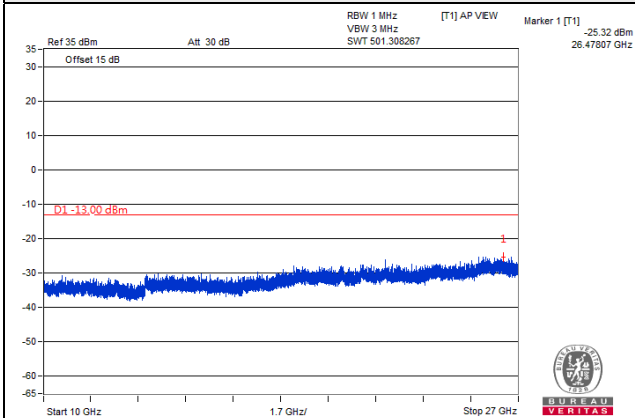

LTE Band 2, Channel Bandwidth 1.4MHz

Channel 18900 (1880.00MHz)

Frequency Range : 9kHz~1GHz

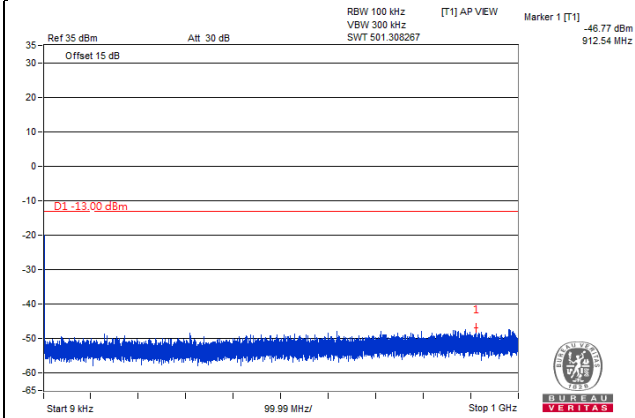

Frequency Range : 1GHz~10GHz

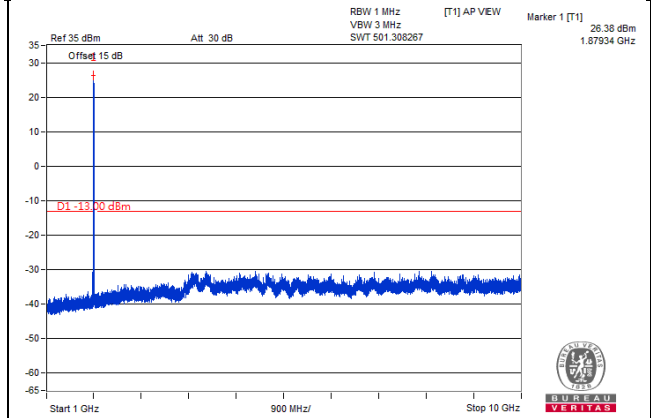

Frequency Range : 10GHz~27GHz

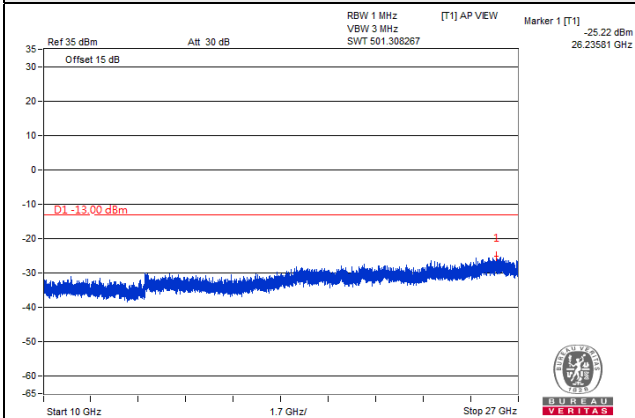

LTE Band 2, Channel Bandwidth 1.4MHz

Channel 19193 (1909.30MHz)

Frequency Range : 9kHz~1GHz

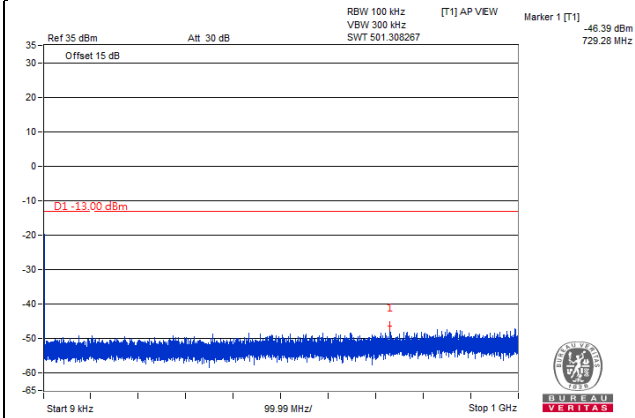

Frequency Range : 1GHz~10GHz

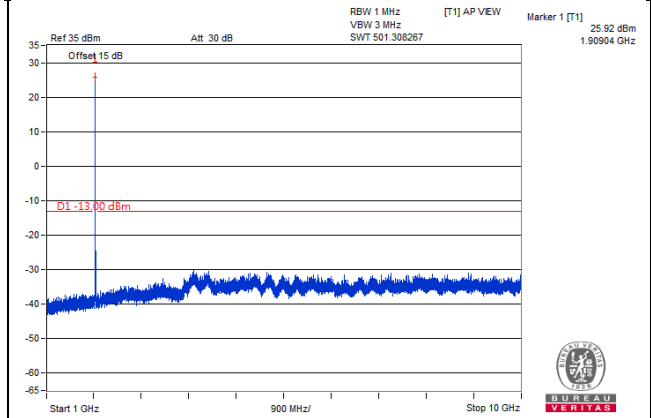

Frequency Range : 10GHz~27GHz

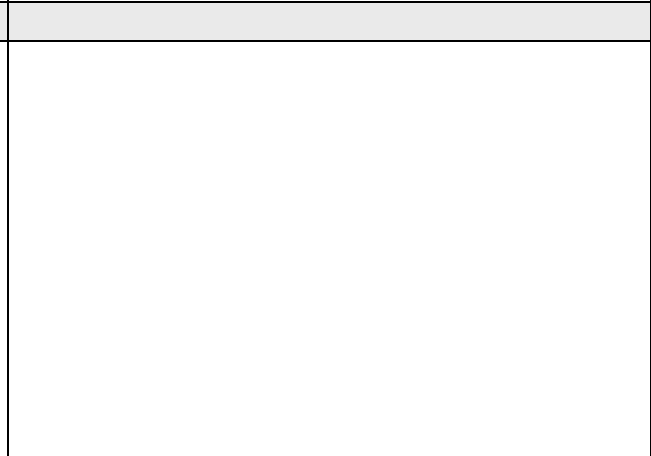
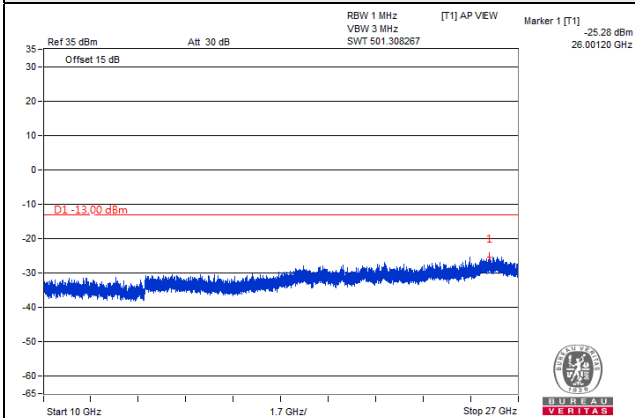

LTE Band 2, Channel Bandwidth 3MHz

Channel 18615 (1851.50MHz)

Frequency Range : 9kHz~1GHz

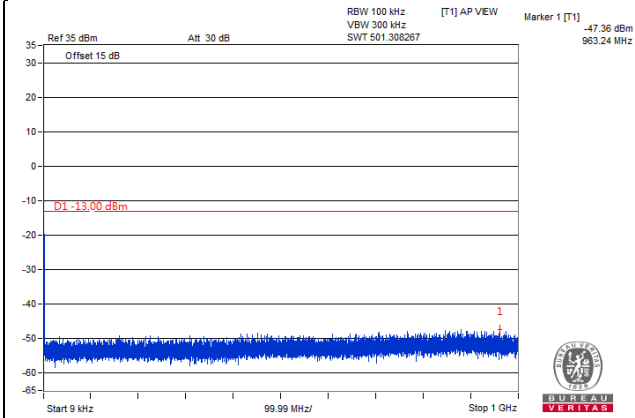

Frequency Range : 1GHz~10GHz

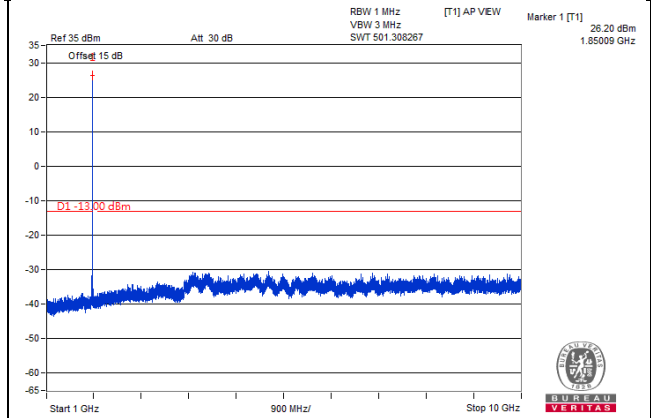

Frequency Range : 10GHz~27GHz

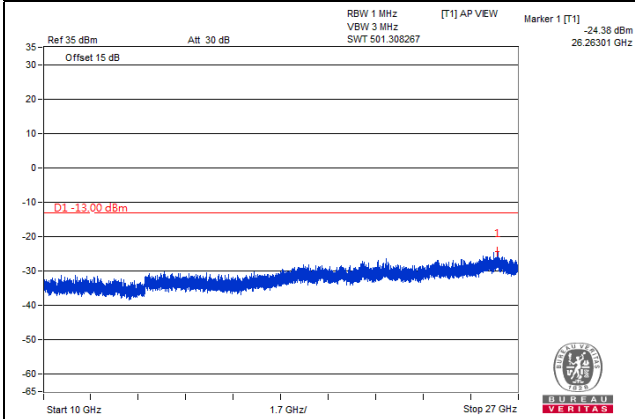

LTE Band 2, Channel Bandwidth 3MHz

Channel 18900 (1880.00MHz)

Frequency Range : 9kHz~1GHz

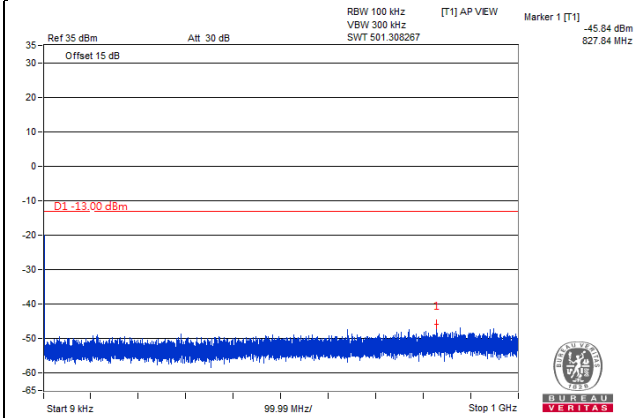

Frequency Range : 1GHz~10GHz

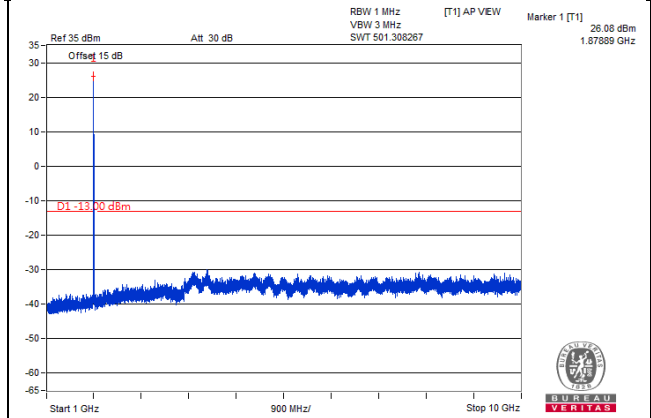

Frequency Range : 10GHz~27GHz

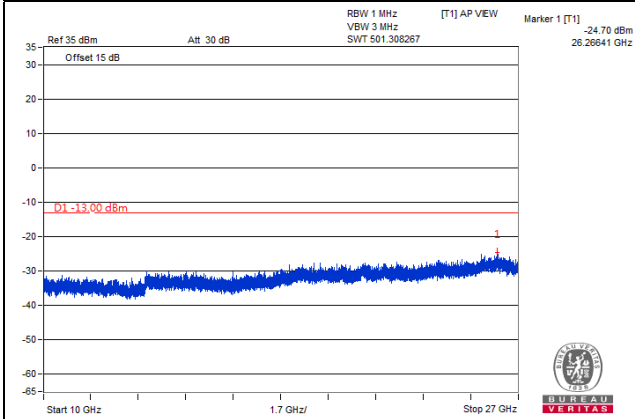

LTE Band 2, Channel Bandwidth 3MHz

Channel 19185 (1908.50MHz)

Frequency Range : 9kHz~1GHz

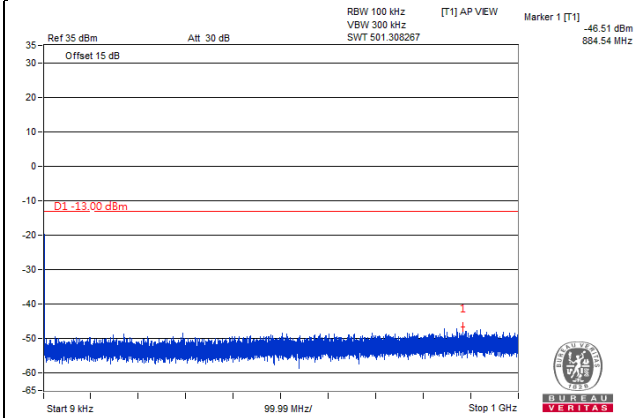

Frequency Range : 1GHz~10GHz

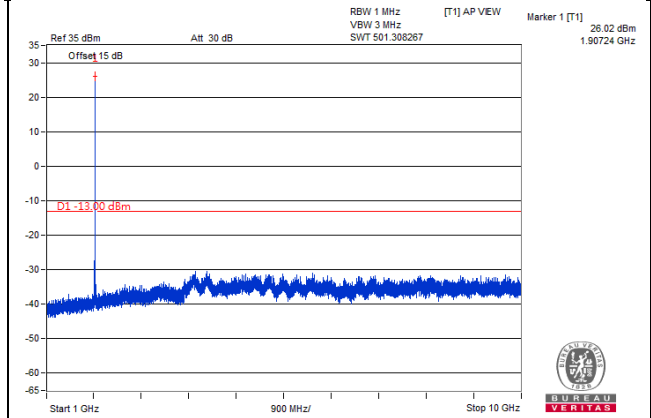

Frequency Range : 10GHz~27GHz

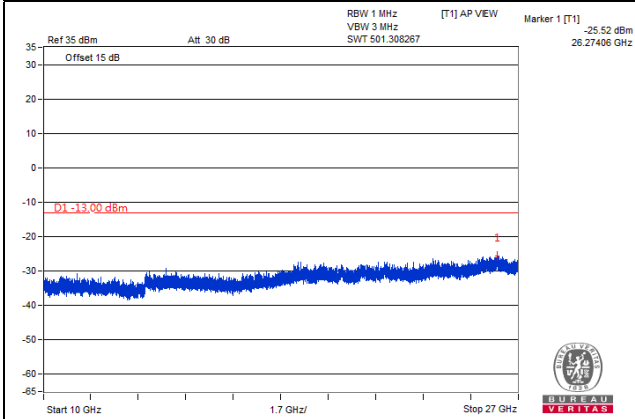

LTE Band 2, Channel Bandwidth 5MHz

Channel 18625 (1852.50MHz)

Frequency Range : 9kHz~1GHz

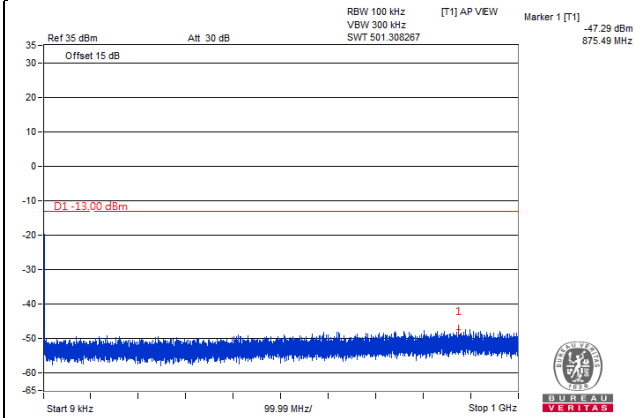

Frequency Range : 1GHz~10GHz

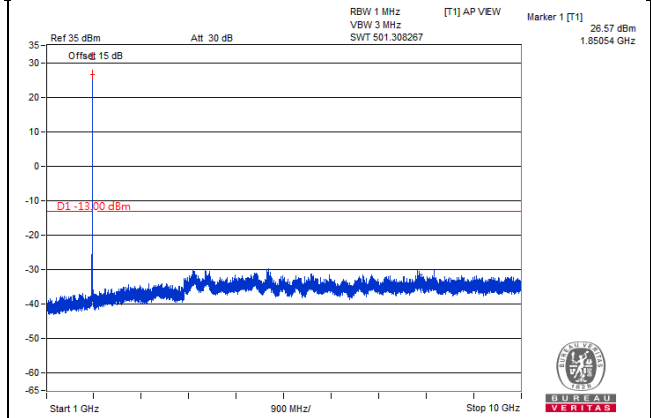

Frequency Range : 10GHz~27GHz

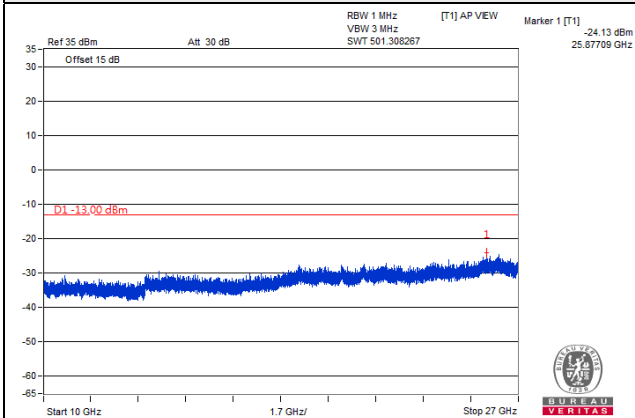

LTE Band 2, Channel Bandwidth 5MHz

Channel 18900 (1880.00MHz)

Frequency Range : 9kHz~1GHz

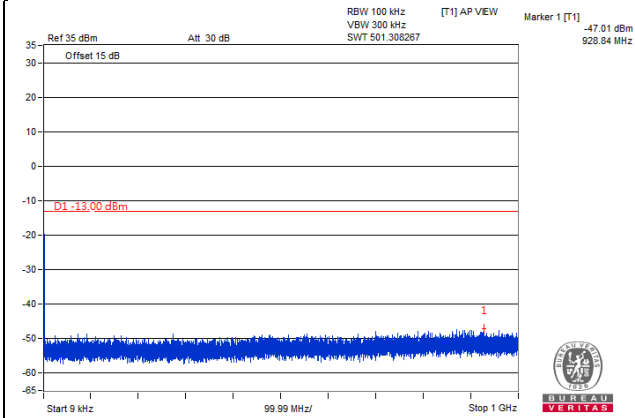

Frequency Range : 1GHz~10GHz

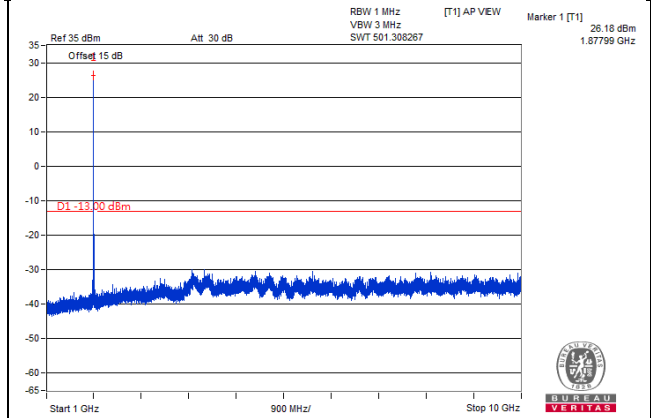

Frequency Range : 10GHz~27GHz

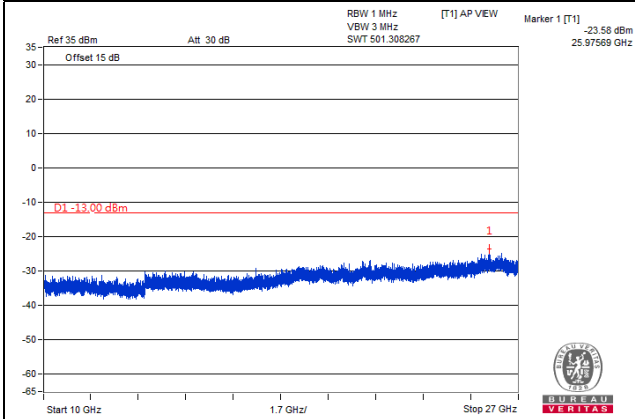



LTE Band 2, Channel Bandwidth 5MHz

Channel 19175 (1907.50MHz)

Frequency Range : 9kHz~1GHz

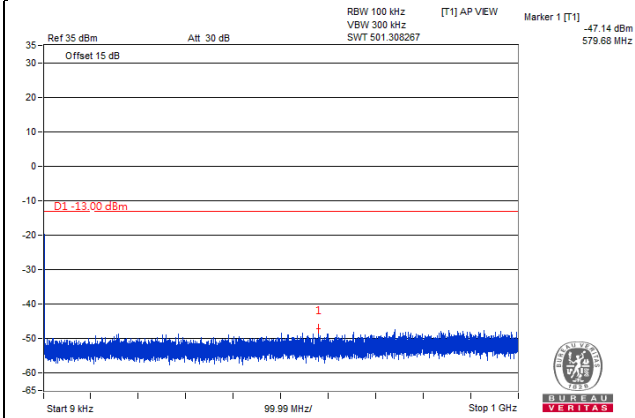

Frequency Range : 1GHz~10GHz

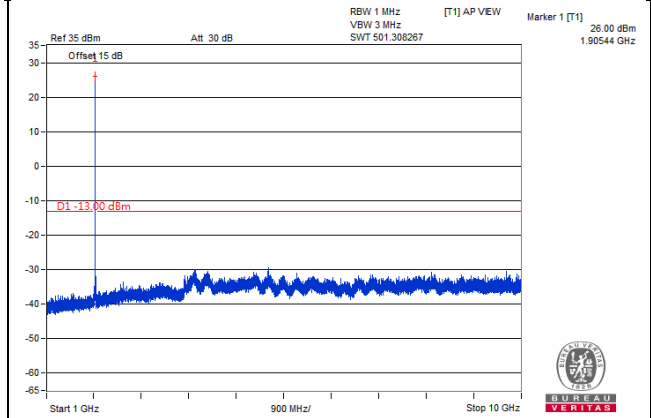

Frequency Range : 10GHz~27GHz

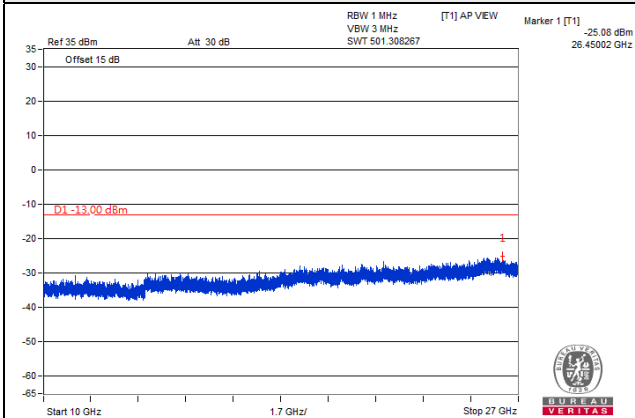

LTE Band 2, Channel Bandwidth 10MHz

Channel 18650 (1855.00MHz)

Frequency Range : 9kHz~1GHz

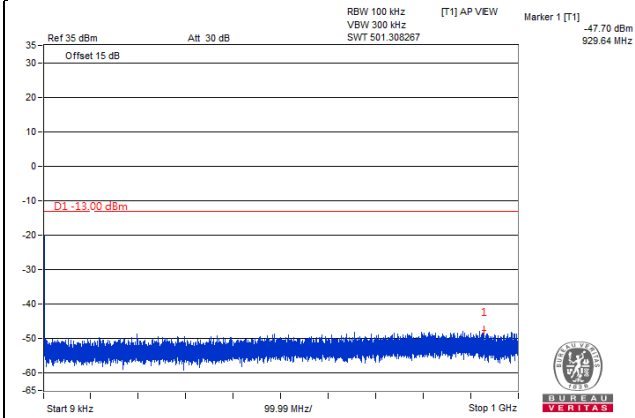

Frequency Range : 1GHz~10GHz

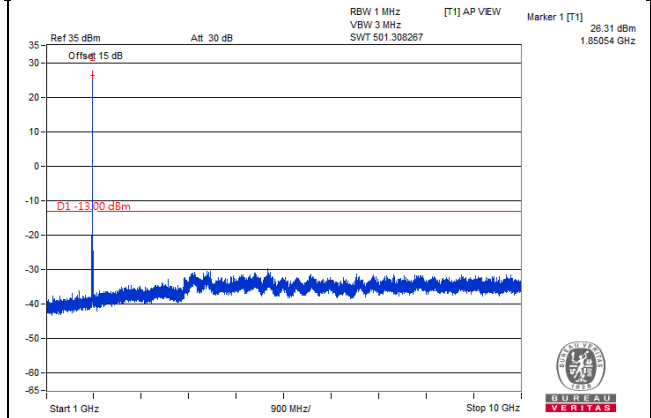

Frequency Range : 10GHz~27GHz

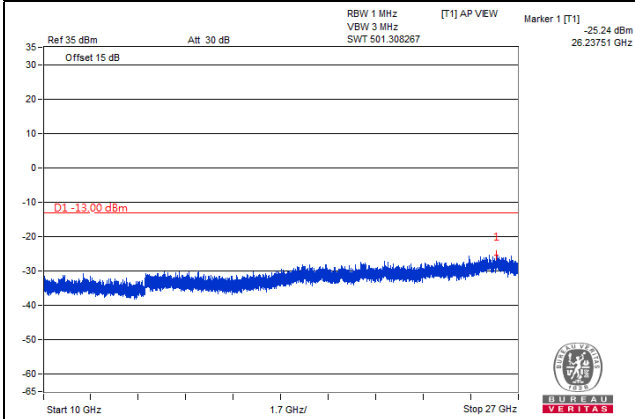

LTE Band 2, Channel Bandwidth 10MHz

Channel 18900 (1880.00MHz)

Frequency Range : 9kHz~1GHz

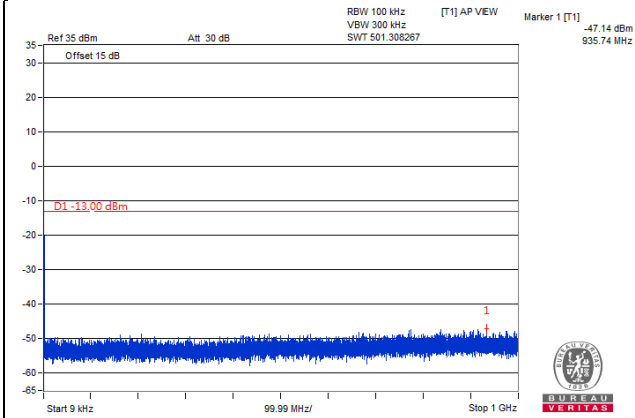

Frequency Range : 1GHz~10GHz

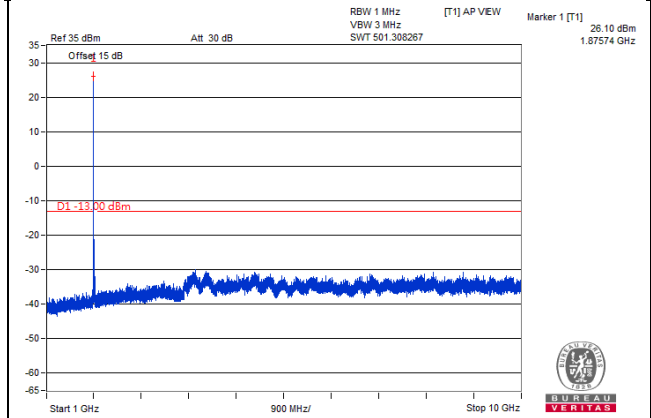

Frequency Range : 10GHz~27GHz

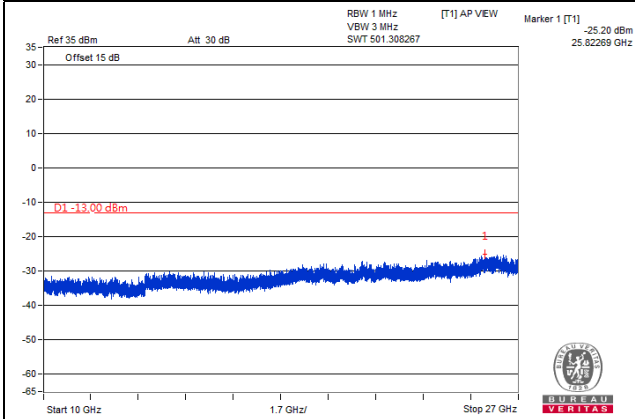

LTE Band 2, Channel Bandwidth 10MHz

Channel 19150 (1905.00MHz)

Frequency Range : 9kHz~1GHz

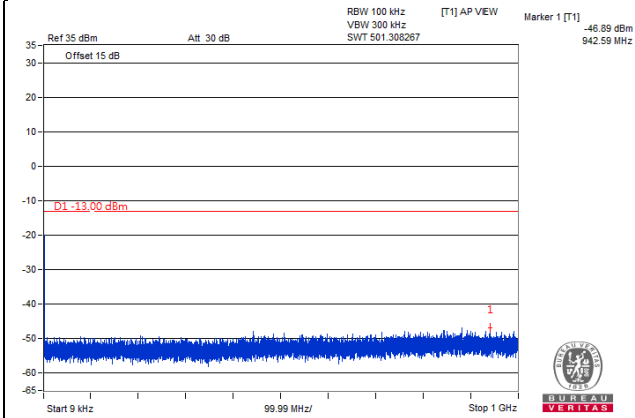

Frequency Range : 1GHz~10GHz

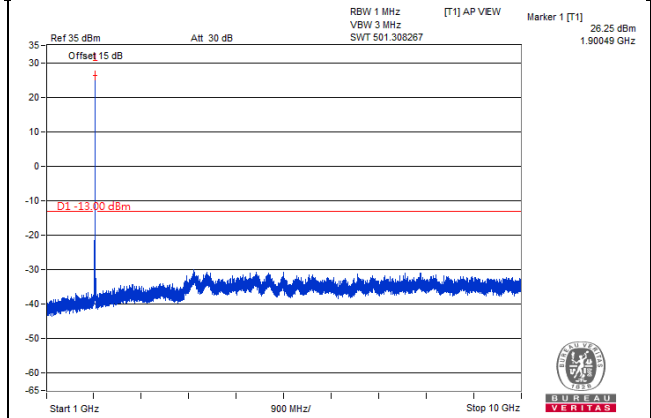

Frequency Range : 10GHz~27GHz

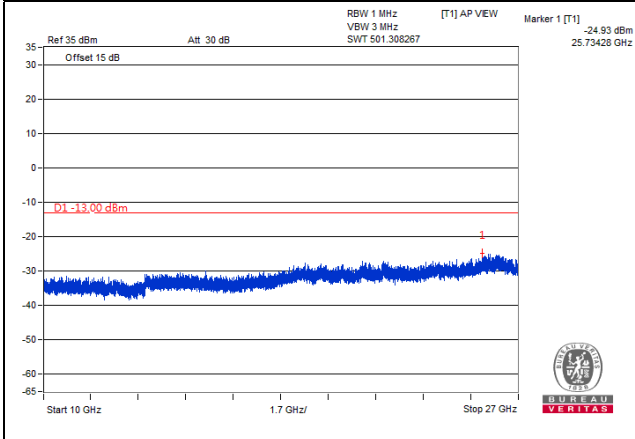

LTE Band 2, Channel Bandwidth 15MHz

Channel 18675 (1857.50MHz)

Frequency Range : 9kHz~1GHz

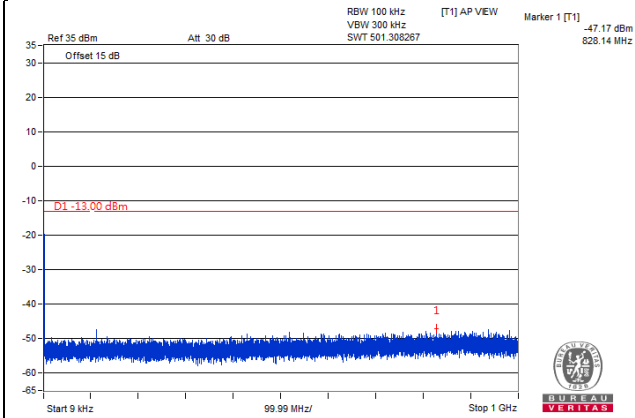

Frequency Range : 1GHz~10GHz

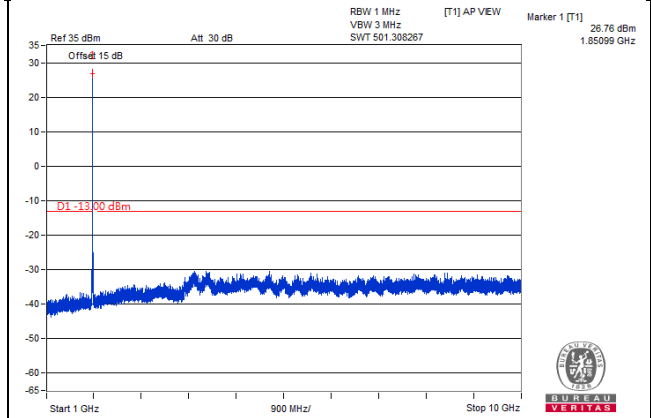

Frequency Range : 10GHz~27GHz

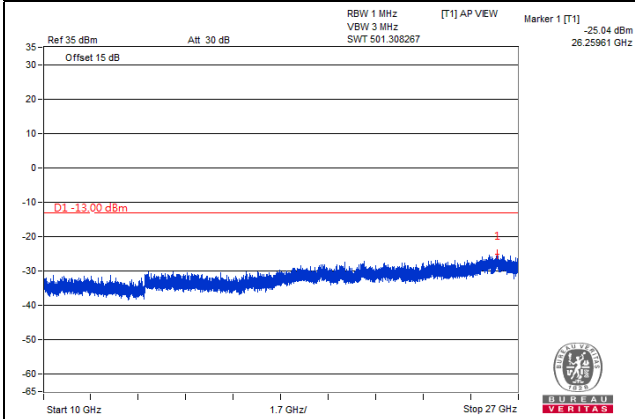

LTE Band 2, Channel Bandwidth 15MHz

Channel 18900 (1880.00MHz)

Frequency Range : 9kHz~1GHz

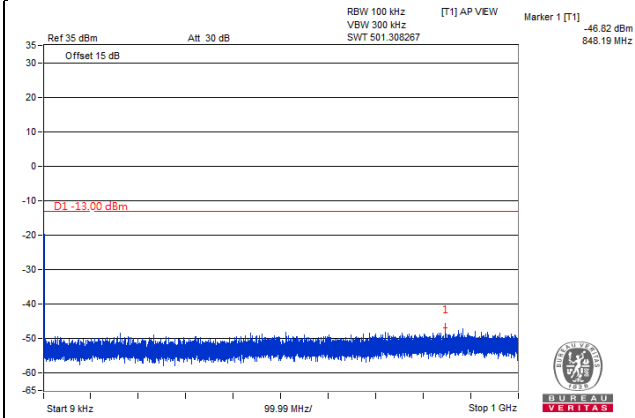

Frequency Range : 1GHz~10GHz

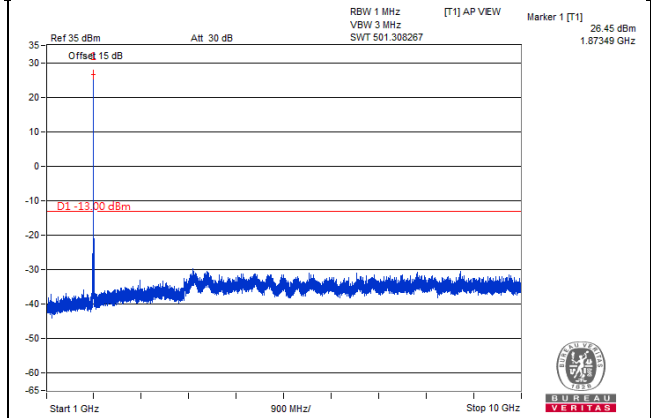

Frequency Range : 10GHz~27GHz

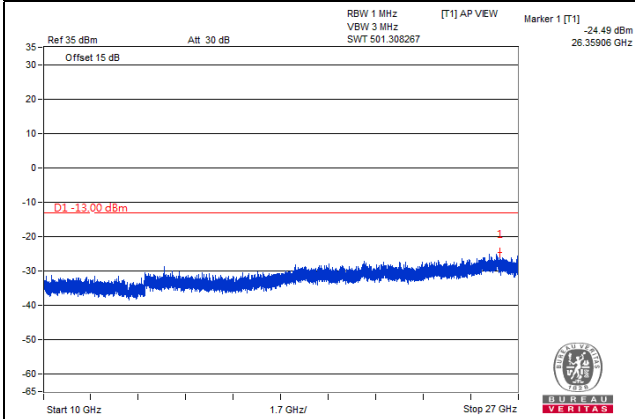

LTE Band 2, Channel Bandwidth 15MHz

Channel 19125 (1902.50MHz)

Frequency Range : 9kHz~1GHz

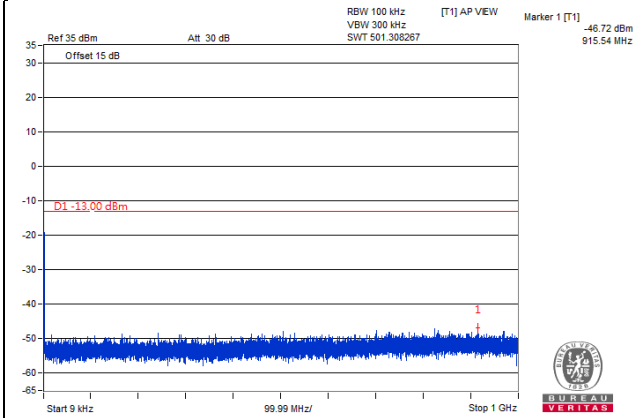

Frequency Range : 1GHz~10GHz

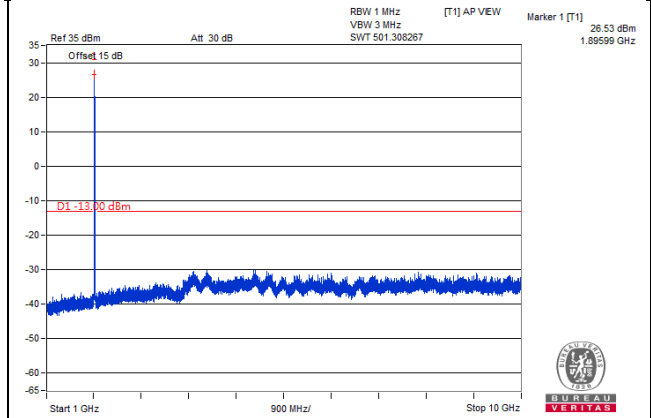

Frequency Range : 10GHz~27GHz

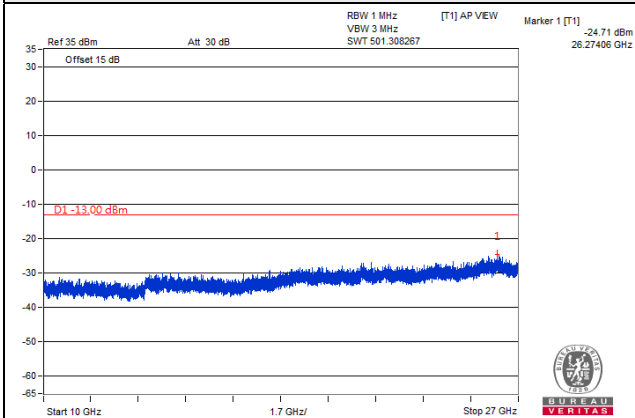

LTE Band 2, Channel Bandwidth 20MHz

Channel 18700 (1860.00MHz)

Frequency Range : 9kHz~1GHz

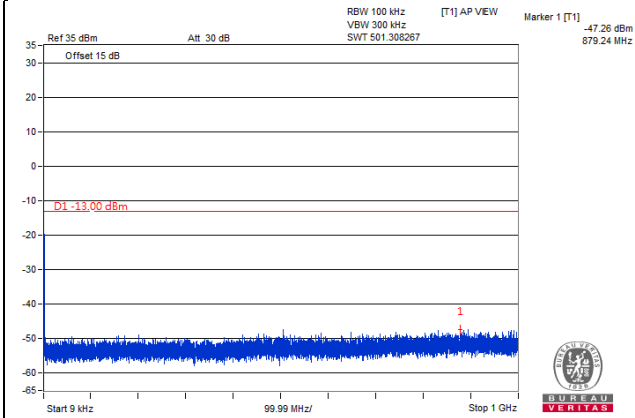

Frequency Range : 1GHz~10GHz

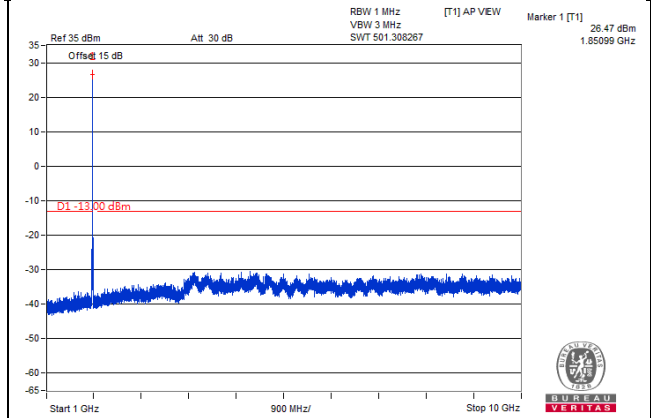

Frequency Range : 10GHz~27GHz

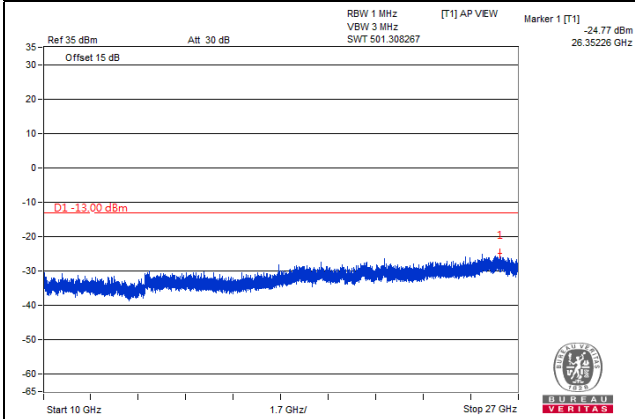



LTE Band 2, Channel Bandwidth 20MHz

Channel 18900 (1880.00MHz)

Frequency Range : 9kHz~1GHz

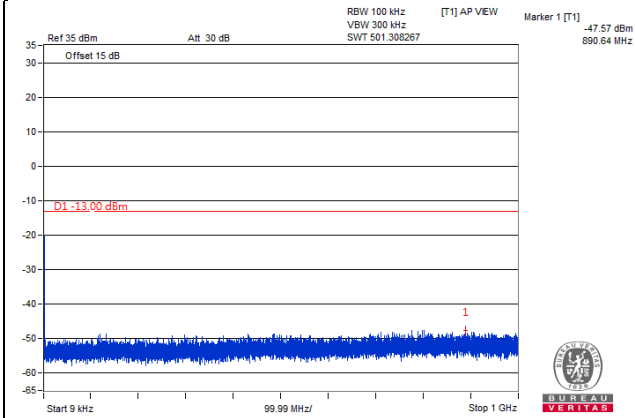

Frequency Range : 1GHz~10GHz

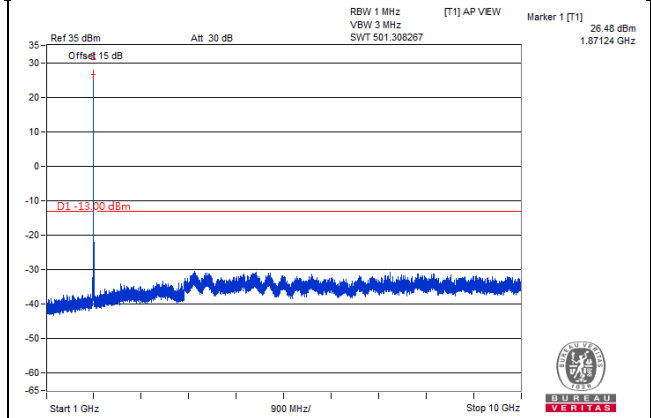

Frequency Range : 10GHz~27GHz

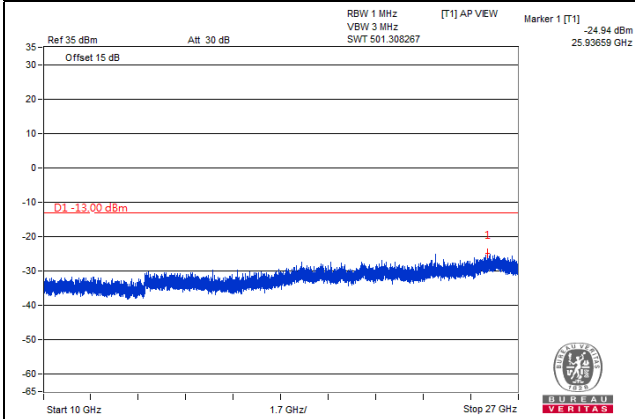

LTE Band 2, Channel Bandwidth 20MHz

Channel 19100 (1900.00MHz)

Frequency Range : 9kHz~1GHz

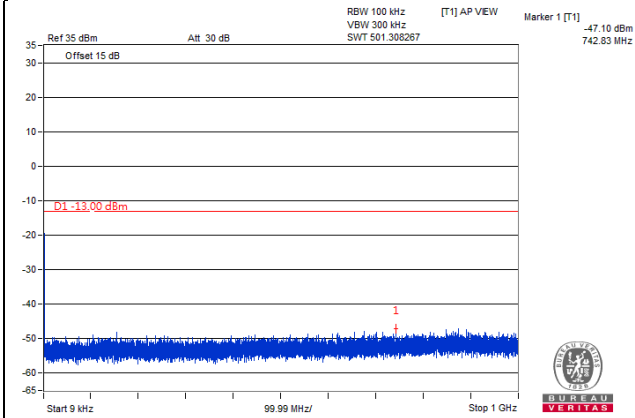

Frequency Range : 1GHz~10GHz

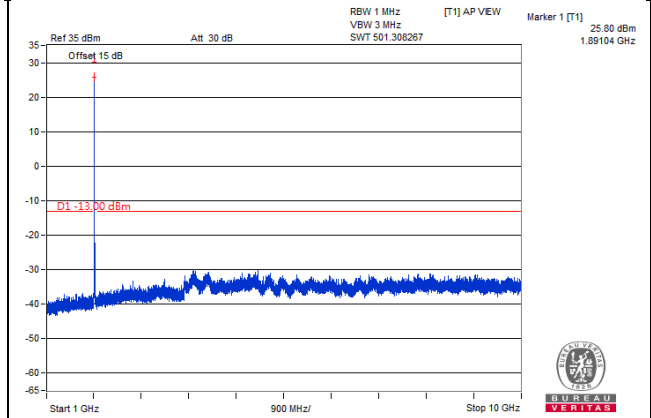

Frequency Range : 10GHz~27GHz

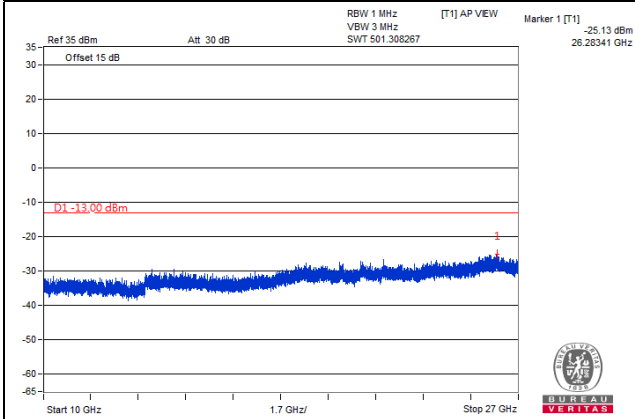

## 4.8 Radiated Emission Measurement

### 4.8.1 Limits of Radiated Emission Measurement

The power of any emission outside of the authorized operating frequency ranges must be attenuated below the transmitting power (P) by a factor of at least  $43 + 10 \log(P)$  dB. The emission limit equal to  $-13\text{dBm}$ .

### 4.8.2 Test Procedure

- a. Substitution method is used for E.I.R.P measurement. In the semi-anechoic chamber, EUT placed on the 0.8m height of Turn Table, rotated the table around 360 degrees to search the maximum radiation power and receiver antenna shall be rotated vertical and horizontal polarization and moved height from 1m to 4m to find the maximum polar radiated power. The "Read Value" is the spectrum reading the maximum power value.
- b. The substitution horn antenna is substituted for EUT at the same position and signals generator export the CW signal to the substitution antenna via a TX cable. Rotated the Turn Table and moved receiving antenna to find the maximum radiation power. Adjust output power level of S.G to get a Value of spectrum reading equal to "Read Value" of step a. Record the power level of S.G
- c.  $\text{EIRP} = \text{Output power level of S.G} - \text{TX cable loss} + \text{Antenna gain of substitution horn}$ .
- d. E.R.P power can be calculated form E.I.R.P power by subtracting the gain of dipole,  $\text{E.R.P power} = \text{E.I.R.P power} - 2.15\text{dBi}$ .

NOTE: The resolution bandwidth and video bandwidth of test receiver/spectrum analyzer is 1MHz/3MHz.

### 4.8.3 Deviation from Test Standard

No deviation.

#### 4.8.4 Test Setup

For radiated emission 30MHz to 1GHz

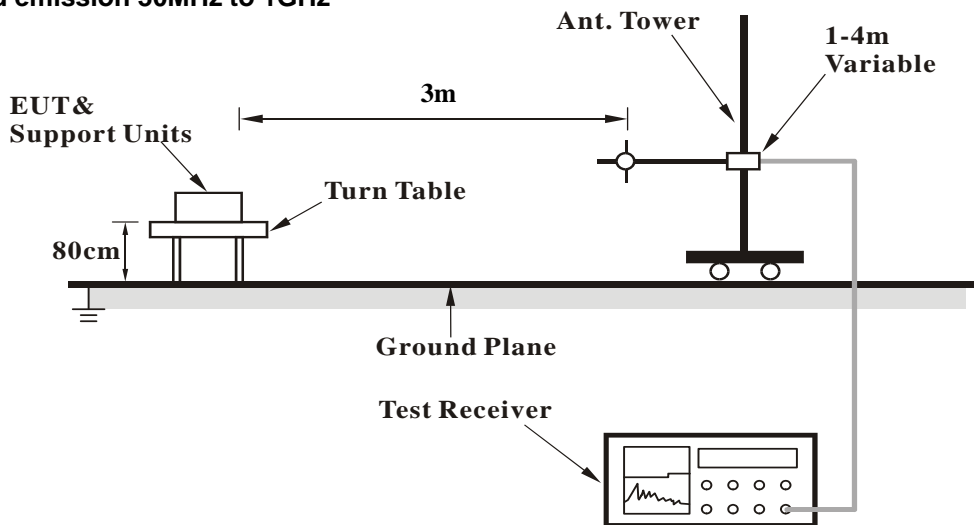

For radiated emission above 1GHz

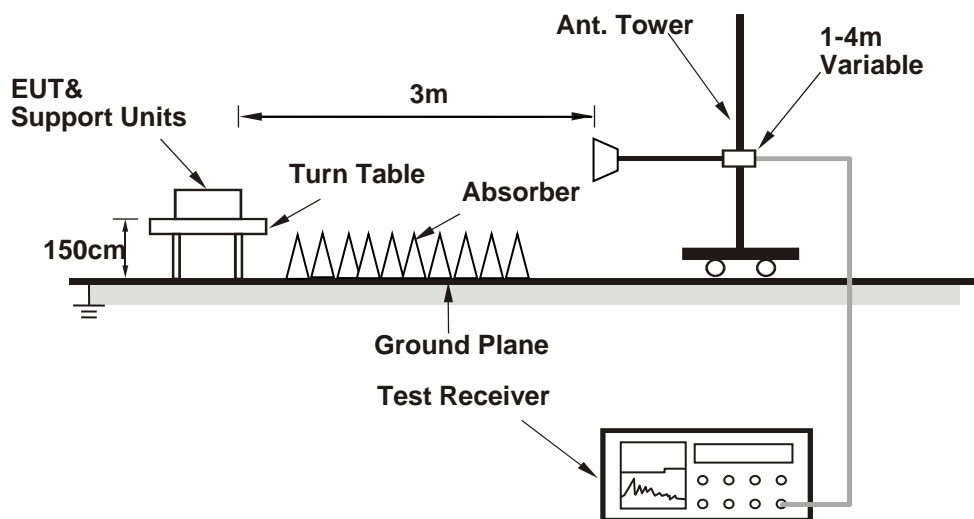

For the actual test configuration, please refer to the attached file (Test Setup Photo).

### 4.8.5 Test Results

Below 1GHz  
GSM Mode

Mode	TX channel 661 (1880.0MHz)	Frequency Range	Below 1000 MHz
Environmental Conditions	25deg. C, 70%RH	Input Power	120Vac, 60Hz
Tested By	Noah Chang		

Antenna Polarity & Test Distance: Horizontal at 3 M							
No.	Freq. (MHz)	Reading (dBm)	S.G Power Value (dBm)	Correction Factor (dB)	EIRP (dBm)	Limit (dBm)	Margin (dB)
1	46.49	-62.80	-52.40	-9.90	-62.30	-13.00	-49.30
2	73.65	-58.30	-64.20	0.10	-64.10	-13.00	-51.10
3	102.75	-58.20	-64.70	-1.80	-66.50	-13.00	-53.50
4	201.69	-60.40	-66.30	-2.20	-68.50	-13.00	-55.50
5	317.12	-66.40	-74.50	4.10	-70.40	-13.00	-57.40
6	366.59	-64.40	-70.60	3.80	-66.80	-13.00	-53.80

Remarks:

1. EIRP (dBm) = S.G Value (dBm) + Correction Factor (dB).
2. Correction Factor (dB) = Substitution Antenna Gain (dB) + Cable Loss (dB).

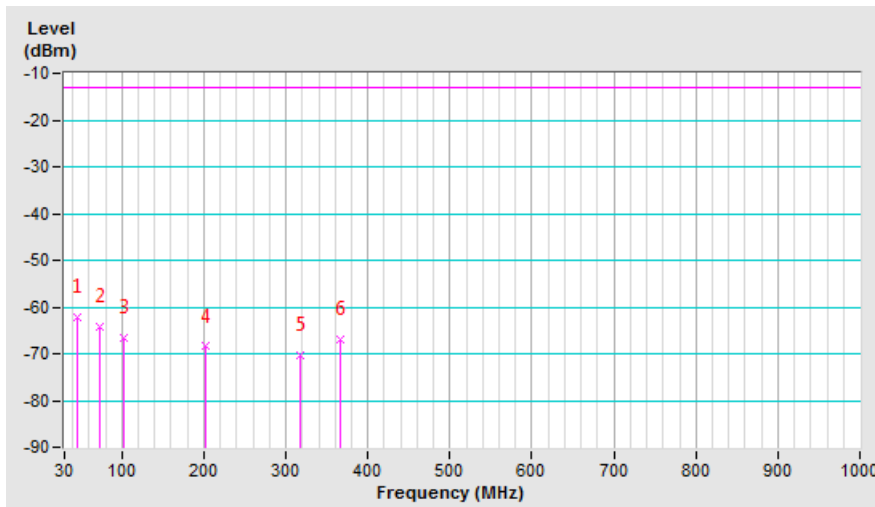

Mode	TX channel 661 (1880.0MHz)	Frequency Range	Below 1000 MHz
Environmental Conditions	25deg. C, 70%RH	Input Power	120Vac, 60Hz
Tested By	Noah Chang		

Antenna Polarity & Test Distance: Vertical at 3 M							
No.	Freq. (MHz)	Reading (dBm)	S.G Power Value (dBm)	Correction Factor (dB)	EIRP (dBm)	Limit (dBm)	Margin (dB)
1	46.49	-51.60	-49.90	-9.90	-59.80	-13.00	-46.80
2	78.50	-51.50	-57.30	0.60	-56.70	-13.00	-43.70
3	102.75	-63.00	-69.70	-1.80	-71.50	-13.00	-58.50
4	195.87	-66.20	-64.60	-2.50	-67.10	-13.00	-54.10
5	364.65	-64.50	-68.70	3.90	-64.80	-13.00	-51.80
6	426.73	-64.90	-68.80	3.50	-65.30	-13.00	-52.30

Remarks:

1. EIRP (dBm) = S.G Value (dBm) + Correction Factor (dB).
2. Correction Factor (dB) = Substitution Antenna Gain (dB) + Cable Loss (dB).

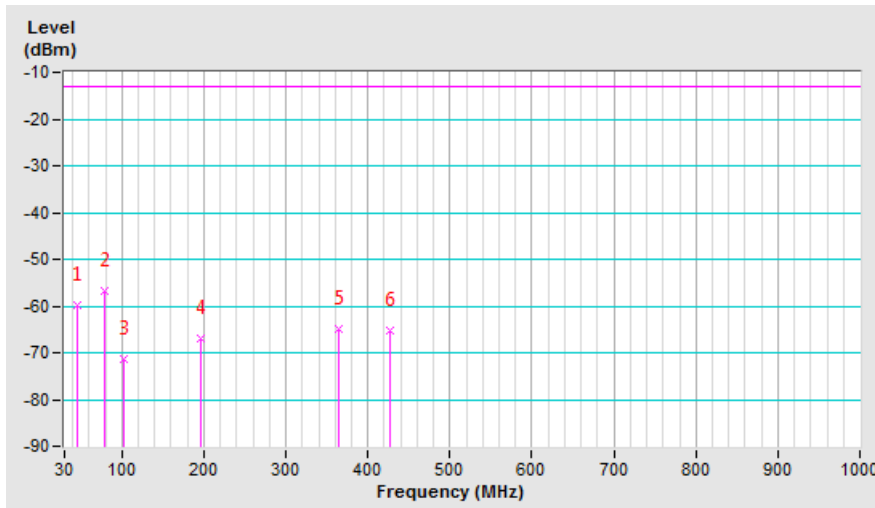

WCDMA Band 2

Mode	TX channel 9538 (1907.6MHz)	Frequency Range	Below 1000 MHz
Environmental Conditions	25deg. C, 70%RH	Input Power	120Vac, 60Hz
Tested By	Noah Chang		

Antenna Polarity & Test Distance: Horizontal at 3 M							
No.	Freq. (MHz)	Reading (dBm)	S.G Power Value (dBm)	Correction Factor (dB)	EIRP (dBm)	Limit (dBm)	Margin (dB)
1	<b>31.94</b>	<b>-49.80</b>	<b>-28.10</b>	<b>-18.30</b>	<b>-46.40</b>	<b>-13.00</b>	<b>-33.40</b>
2	46.49	-62.70	-52.30	-9.90	-62.20	-13.00	-49.20
3	75.59	-59.00	-65.00	0.20	-64.80	-13.00	-51.80
4	103.72	-57.40	-63.80	-2.00	-65.80	-13.00	-52.80
5	143.49	-60.90	-63.00	-3.10	-66.10	-13.00	-53.10
6	201.69	-60.60	-66.50	-2.20	-68.70	-13.00	-55.70

Remarks:

1. EIRP (dBm) = S.G Value (dBm) + Correction Factor (dB).
2. Correction Factor (dB) = Substitution Antenna Gain (dB) + Cable Loss (dB).

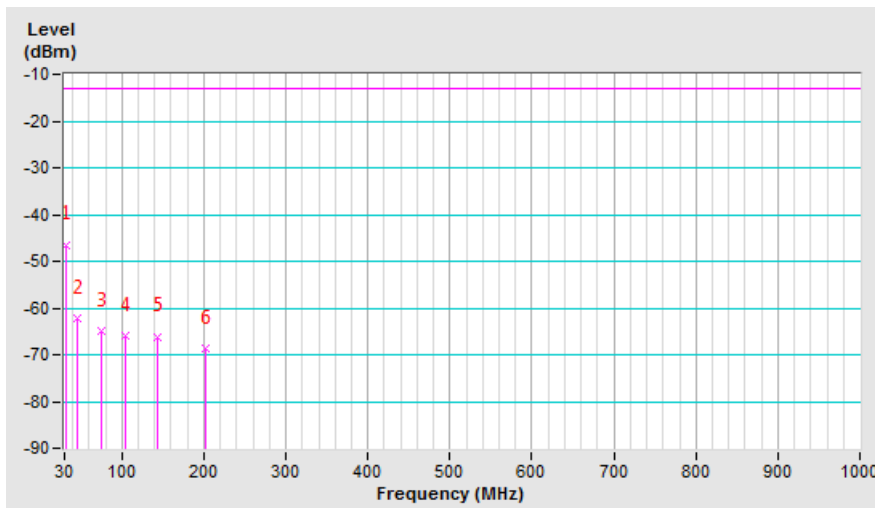

Mode	TX channel 9538 (1907.6MHz)	Frequency Range	Below 1000 MHz
Environmental Conditions	25deg. C, 70%RH	Input Power	120Vac, 60Hz
Tested By	Noah Chang		

Antenna Polarity & Test Distance: Vertical at 3 M							
No.	Freq. (MHz)	Reading (dBm)	S.G Power Value (dBm)	Correction Factor (dB)	EIRP (dBm)	Limit (dBm)	Margin (dB)
1	31.94	-38.40	-30.60	-18.30	-48.90	-13.00	-35.90
2	47.46	-51.50	-50.20	-9.20	-59.40	-13.00	-46.40
3	79.47	-50.60	-56.10	0.60	-55.50	-13.00	-42.50
4	145.43	-64.20	-63.10	-3.10	-66.20	-13.00	-53.20
5	202.66	-63.90	-63.30	-2.10	-65.40	-13.00	-52.40
6	277.35	-65.50	-60.60	-1.60	-62.20	-13.00	-49.20

Remarks:

1. EIRP (dBm) = S.G Value (dBm) + Correction Factor (dB).
2. Correction Factor (dB) = Substitution Antenna Gain (dB) + Cable Loss (dB).

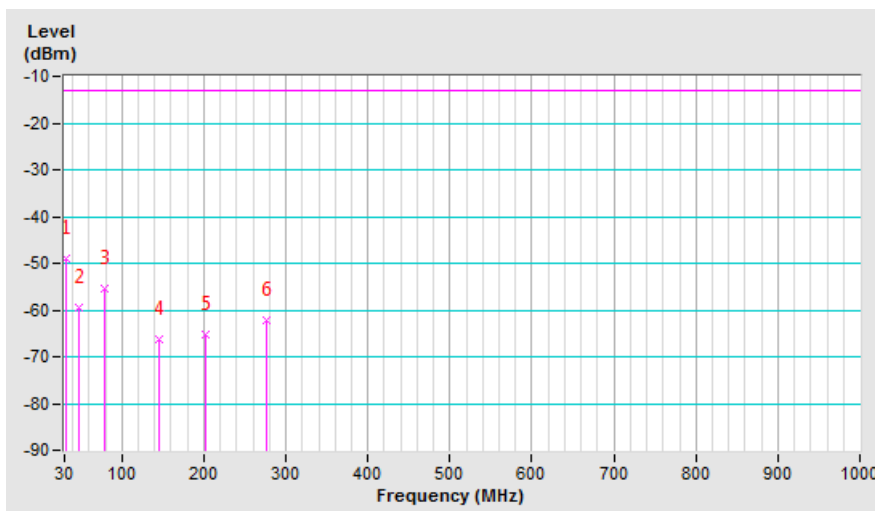



LTE Band 2, Channel Bandwidth: 1.4MHz

Mode	TX channel 18607 (1850.70MHz)	Frequency Range	Below 1000 MHz
Environmental Conditions	25deg. C, 70%RH	Input Power	120Vac, 60Hz
Tested By	Noah Chang		

Antenna Polarity & Test Distance: Horizontal at 3 M							
No.	Freq. (MHz)	Reading (dBm)	S.G Power Value (dBm)	Correction Factor (dB)	EIRP (dBm)	Limit (dBm)	Margin (dB)
1	32.91	-67.10	-46.30	-17.70	-64.00	-13.00	-51.00
2	73.65	-57.80	-63.70	0.10	-63.60	-13.00	-50.60
3	128.94	-44.80	-47.80	-3.20	-51.00	-13.00	-38.00
4	189.08	-53.70	-59.30	-2.80	-62.10	-13.00	-49.10
5	210.42	-51.10	-57.60	-2.00	-59.60	-13.00	-46.60
6	281.23	-59.50	-62.10	-1.70	-63.80	-13.00	-50.80

Remarks:

1. EIRP (dBm) = S.G Value (dBm) + Correction Factor (dB).
2. Correction Factor (dB) = Substitution Antenna Gain (dB) + Cable Loss (dB).

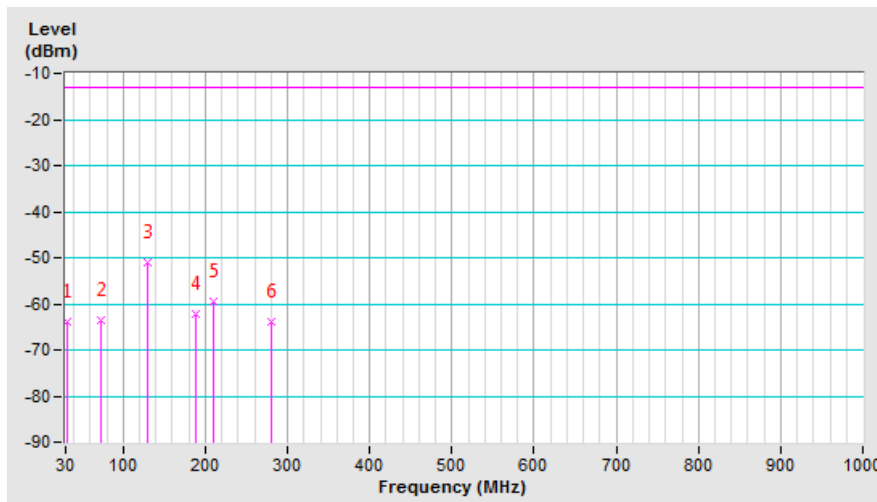

Mode	TX channel 18607 (1850.70MHz)	Frequency Range	Below 1000 MHz
Environmental Conditions	25deg. C, 70%RH	Input Power	120Vac, 60Hz
Tested By	Noah Chang		

Antenna Polarity & Test Distance: Vertical at 3 M							
No.	Freq. (MHz)	Reading (dBm)	S.G Power Value (dBm)	Correction Factor (dB)	EIRP (dBm)	Limit (dBm)	Margin (dB)
1	67.83	-51.50	-57.40	-1.00	-58.40	-13.00	-45.40
2	139.61	-68.20	-67.90	-3.10	-71.00	-13.00	-58.00
3	188.11	-66.50	-66.00	-2.70	-68.70	-13.00	-55.70
4	287.05	-67.70	-64.20	-1.70	-65.90	-13.00	-52.90
5	319.06	-67.70	-71.80	4.00	-67.80	-13.00	-54.80
6	420.91	-66.60	-70.40	3.50	-66.90	-13.00	-53.90

Remarks:

1. EIRP (dBm) = S.G Value (dBm) + Correction Factor (dB).
2. Correction Factor (dB) = Substitution Antenna Gain (dB) + Cable Loss (dB).

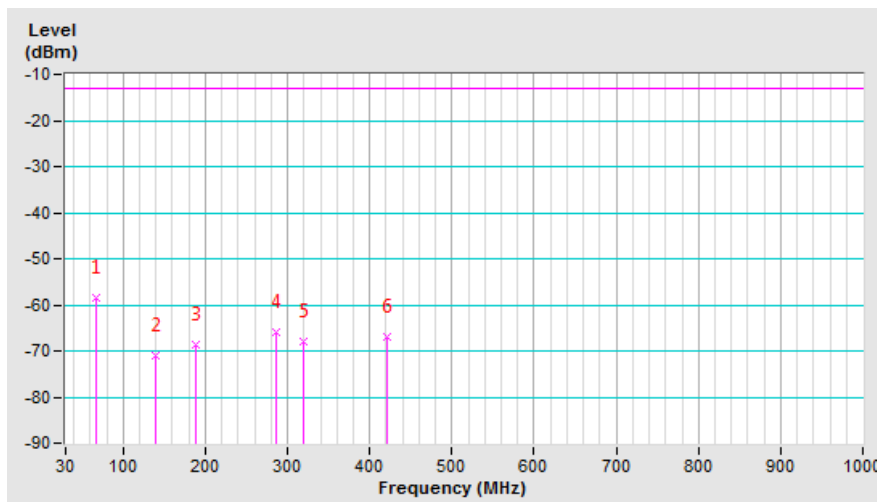

Above 1GHz  
GSM Mode

Mode	TX channel 512 (1850.2MHz)	Frequency Range	1GHz ~ 20GHz
Environmental Conditions	25deg. C, 70%RH	Input Power	120Vac, 60Hz
Tested By	Noah Chang		

Antenna Polarity & Test Distance: Horizontal at 3 M							
No.	Freq. (MHz)	Reading (dBm)	S.G Power Value (dBm)	Correction Factor (dB)	EIRP (dBm)	Limit (dBm)	Margin (dB)
1	3700.40	-59.80	-51.30	1.40	-49.90	-13.00	-36.90
Antenna Polarity & Test Distance: Vertical at 3 M							
No.	Freq. (MHz)	Reading (dBm)	S.G Power Value (dBm)	Correction Factor (dB)	EIRP (dBm)	Limit (dBm)	Margin (dB)
1	3700.40	-61.50	-53.30	1.40	-51.90	-13.00	-38.90

Remarks:

1. EIRP (dBm) = S.G Value (dBm) + Correction Factor (dB).
2. Correction Factor (dB) = Substitution Antenna Gain (dB) + Cable Loss (dB).

Mode	TX channel 661 (1880.0MHz)	Frequency Range	1GHz ~ 20GHz
Environmental Conditions	25deg. C, 70%RH	Input Power	120Vac, 60Hz
Tested By	Noah Chang		

Antenna Polarity & Test Distance: Horizontal at 3 M							
No.	Freq. (MHz)	Reading (dBm)	S.G Power Value (dBm)	Correction Factor (dB)	EIRP (dBm)	Limit (dBm)	Margin (dB)
1	3760.00	-60.10	-51.60	1.30	-50.30	-13.00	-37.30
Antenna Polarity & Test Distance: Vertical at 3 M							
No.	Freq. (MHz)	Reading (dBm)	S.G Power Value (dBm)	Correction Factor (dB)	EIRP (dBm)	Limit (dBm)	Margin (dB)
1	3760.00	-61.90	-53.60	1.30	-52.30	-13.00	-39.30

Remarks:

1. EIRP (dBm) = S.G Value (dBm) + Correction Factor (dB).
2. Correction Factor (dB) = Substitution Antenna Gain (dB) + Cable Loss (dB).

Mode	TX channel 810 (1909.8MHz)	Frequency Range	1GHz ~ 20GHz
Environmental Conditions	25deg. C, 70%RH	Input Power	120Vac, 60Hz
Tested By	Noah Chang		

Antenna Polarity & Test Distance: Horizontal at 3 M							
No.	Freq. (MHz)	Reading (dBm)	S.G Power Value (dBm)	Correction Factor (dB)	EIRP (dBm)	Limit (dBm)	Margin (dB)
1	3819.60	-59.70	-52.00	-0.10	-52.10	-13.00	-39.10
Antenna Polarity & Test Distance: Vertical at 3 M							
No.	Freq. (MHz)	Reading (dBm)	S.G Power Value (dBm)	Correction Factor (dB)	EIRP (dBm)	Limit (dBm)	Margin (dB)
1	3819.60	-61.20	-54.00	-0.10	-54.10	-13.00	-41.10

Remarks:

1. EIRP (dBm) = S.G Value (dBm) + Correction Factor (dB).
2. Correction Factor (dB) = Substitution Antenna Gain (dB) + Cable Loss (dB).

WCDMA Band 2

Mode	TX channel 9262 (1852.4MHz)	Frequency Range	1GHz ~ 20GHz
Environmental Conditions	25deg. C, 70%RH	Input Power	120Vac, 60Hz
Tested By	Noah Chang		

Antenna Polarity & Test Distance: Horizontal at 3 M							
No.	Freq. (MHz)	Reading (dBm)	S.G Power Value (dBm)	Correction Factor (dB)	EIRP (dBm)	Limit (dBm)	Margin (dB)
1	3704.80	-59.60	-51.10	1.40	-49.70	-13.00	-36.70
Antenna Polarity & Test Distance: Vertical at 3 M							
No.	Freq. (MHz)	Reading (dBm)	S.G Power Value (dBm)	Correction Factor (dB)	EIRP (dBm)	Limit (dBm)	Margin (dB)
1	3704.80	-61.80	-53.60	1.40	-52.20	-13.00	-39.20

Remarks:

1. EIRP (dBm) = S.G Value (dBm) + Correction Factor (dB).
2. Correction Factor (dB) = Substitution Antenna Gain (dB) + Cable Loss (dB).

Mode	TX channel 9400 (1880.0MHz)	Frequency Range	1GHz ~ 20GHz
Environmental Conditions	25deg. C, 70%RH	Input Power	120Vac, 60Hz
Tested By	Noah Chang		

Antenna Polarity & Test Distance: Horizontal at 3 M							
No.	Freq. (MHz)	Reading (dBm)	S.G Power Value (dBm)	Correction Factor (dB)	EIRP (dBm)	Limit (dBm)	Margin (dB)
1	3760.00	-60.30	-51.80	1.30	-50.50	-13.00	-37.50
Antenna Polarity & Test Distance: Vertical at 3 M							
No.	Freq. (MHz)	Reading (dBm)	S.G Power Value (dBm)	Correction Factor (dB)	EIRP (dBm)	Limit (dBm)	Margin (dB)
1	3760.00	-62.10	-53.80	1.30	-52.50	-13.00	-39.50

Remarks:

1. EIRP (dBm) = S.G Value (dBm) + Correction Factor (dB).
2. Correction Factor (dB) = Substitution Antenna Gain (dB) + Cable Loss (dB).

Mode	TX channel 9538 (1907.6MHz)	Frequency Range	1GHz ~ 20GHz
Environmental Conditions	25deg. C, 70%RH	Input Power	120Vac, 60Hz
Tested By	Noah Chang		

Antenna Polarity & Test Distance: Horizontal at 3 M							
No.	Freq. (MHz)	Reading (dBm)	S.G Power Value (dBm)	Correction Factor (dB)	EIRP (dBm)	Limit (dBm)	Margin (dB)
1	3815.20	-59.40	-51.10	1.40	-49.70	-13.00	-36.70
Antenna Polarity & Test Distance: Vertical at 3 M							
No.	Freq. (MHz)	Reading (dBm)	S.G Power Value (dBm)	Correction Factor (dB)	EIRP (dBm)	Limit (dBm)	Margin (dB)
1	3815.20	-61.30	-53.10	1.40	-51.70	-13.00	-38.70

Remarks:

1. EIRP (dBm) = S.G Value (dBm) + Correction Factor (dB).
2. Correction Factor (dB) = Substitution Antenna Gain (dB) + Cable Loss (dB).

LTE Band 2, Channel Bandwidth 1.4MHz

Mode	TX channel 18607 (1850.70MHz)	Frequency Range	1GHz ~ 20GHz
Environmental Conditions	25deg. C, 70%RH	Input Power	120Vac, 60Hz
Tested By	Noah Chang		

Antenna Polarity & Test Distance: Horizontal at 3 M							
No.	Freq. (MHz)	Reading (dBm)	S.G Power Value (dBm)	Correction Factor (dB)	EIRP (dBm)	Limit (dBm)	Margin (dB)
1	3701.40	-73.30	-67.30	7.10	-60.20	-13.00	-47.20
Antenna Polarity & Test Distance: Vertical at 3 M							
No.	Freq. (MHz)	Reading (dBm)	S.G Power Value (dBm)	Correction Factor (dB)	EIRP (dBm)	Limit (dBm)	Margin (dB)
1	3701.40	-76.50	-69.50	7.10	-62.40	-13.00	-49.40

Remarks:

1. EIRP (dBm) = S.G Value (dBm) + Correction Factor (dB).
2. Correction Factor (dB) = Substitution Antenna Gain (dB) + Cable Loss (dB).

Mode	TX channel 18900 (1880.00MHz)	Frequency Range	1GHz ~ 20GHz
Environmental Conditions	25deg. C, 70%RH	Input Power	120Vac, 60Hz
Tested By	Noah Chang		

Antenna Polarity & Test Distance: Horizontal at 3 M							
No.	Freq. (MHz)	Reading (dBm)	S.G Power Value (dBm)	Correction Factor (dB)	EIRP (dBm)	Limit (dBm)	Margin (dB)
1	3760.00	-73.70	-67.20	7.10	-60.10	-13.00	-47.10
Antenna Polarity & Test Distance: Vertical at 3 M							
No.	Freq. (MHz)	Reading (dBm)	S.G Power Value (dBm)	Correction Factor (dB)	EIRP (dBm)	Limit (dBm)	Margin (dB)
1	3760.00	-75.30	-67.90	7.10	-60.80	-13.00	-47.80

Remarks:

1. EIRP (dBm) = S.G Value (dBm) + Correction Factor (dB).
2. Correction Factor (dB) = Substitution Antenna Gain (dB) + Cable Loss (dB).

Mode	TX channel 19193 (1909.30MHz)	Frequency Range	1GHz ~ 20GHz
Environmental Conditions	25deg. C, 70%RH	Input Power	120Vac, 60Hz
Tested By	Noah Chang		

Antenna Polarity & Test Distance: Horizontal at 3 M							
No.	Freq. (MHz)	Reading (dBm)	S.G Power Value (dBm)	Correction Factor (dB)	EIRP (dBm)	Limit (dBm)	Margin (dB)
1	3818.60	-74.00	-67.30	7.10	-60.20	-13.00	-47.20
Antenna Polarity & Test Distance: Vertical at 3 M							
No.	Freq. (MHz)	Reading (dBm)	S.G Power Value (dBm)	Correction Factor (dB)	EIRP (dBm)	Limit (dBm)	Margin (dB)
1	3818.60	-75.30	-67.60	7.10	-60.50	-13.00	-47.50

Remarks:

1.  $EIRP (dBm) = S.G \text{ Value (dBm)} + \text{Correction Factor (dB)}$ .
2.  $\text{Correction Factor (dB)} = \text{Substitution Antenna Gain (dB)} + \text{Cable Loss (dB)}$ .



LTE Band 2, Channel Bandwidth 5MHz

Mode	TX channel 18625 (1852.50MHz)	Frequency Range	1GHz ~ 20GHz
Environmental Conditions	25deg. C, 70%RH	Input Power	120Vac, 60Hz
Tested By	Noah Chang		

Antenna Polarity & Test Distance: Horizontal at 3 M							
No.	Freq. (MHz)	Reading (dBm)	S.G Power Value (dBm)	Correction Factor (dB)	EIRP (dBm)	Limit (dBm)	Margin (dB)
1	3705.00	-73.60	-67.60	7.10	-60.50	-13.00	-47.50
Antenna Polarity & Test Distance: Vertical at 3 M							
No.	Freq. (MHz)	Reading (dBm)	S.G Power Value (dBm)	Correction Factor (dB)	EIRP (dBm)	Limit (dBm)	Margin (dB)
1	3705.00	-76.70	-69.60	7.10	-62.50	-13.00	-49.50

Remarks:

1. EIRP (dBm) = S.G Value (dBm) + Correction Factor (dB).
2. Correction Factor (dB) = Substitution Antenna Gain (dB) + Cable Loss (dB).

Mode	TX channel 18900 (1880.00MHz)	Frequency Range	1GHz ~ 20GHz
Environmental Conditions	25deg. C, 70%RH	Input Power	120Vac, 60Hz
Tested By	Noah Chang		

Antenna Polarity & Test Distance: Horizontal at 3 M							
No.	Freq. (MHz)	Reading (dBm)	S.G Power Value (dBm)	Correction Factor (dB)	EIRP (dBm)	Limit (dBm)	Margin (dB)
1	3760.00	-74.20	-67.70	7.10	-60.60	-13.00	-47.60
Antenna Polarity & Test Distance: Vertical at 3 M							
No.	Freq. (MHz)	Reading (dBm)	S.G Power Value (dBm)	Correction Factor (dB)	EIRP (dBm)	Limit (dBm)	Margin (dB)
1	3760.00	-75.30	-67.90	7.10	-60.80	-13.00	-47.80

Remarks:

1. EIRP (dBm) = S.G Value (dBm) + Correction Factor (dB).
2. Correction Factor (dB) = Substitution Antenna Gain (dB) + Cable Loss (dB).

Mode	TX channel 19175 (1907.50MHz)	Frequency Range	1GHz ~ 20GHz
Environmental Conditions	25deg. C, 70%RH	Input Power	120Vac, 60Hz
Tested By	Noah Chang		

Antenna Polarity & Test Distance: Horizontal at 3 M							
No.	Freq. (MHz)	Reading (dBm)	S.G Power Value (dBm)	Correction Factor (dB)	EIRP (dBm)	Limit (dBm)	Margin (dB)
1	3815.00	-75.30	-68.50	7.10	-61.40	-13.00	-48.40
Antenna Polarity & Test Distance: Vertical at 3 M							
No.	Freq. (MHz)	Reading (dBm)	S.G Power Value (dBm)	Correction Factor (dB)	EIRP (dBm)	Limit (dBm)	Margin (dB)
1	3815.00	-75.90	-68.20	7.10	-61.10	-13.00	-48.10

Remarks:

1. EIRP (dBm) = S.G Value (dBm) + Correction Factor (dB).
2. Correction Factor (dB) = Substitution Antenna Gain (dB) + Cable Loss (dB).

LTE Band 2, Channel Bandwidth 20MHz

Mode	TX channel 18700 (1860.00MHz)	Frequency Range	1GHz ~ 20GHz
Environmental Conditions	25deg. C, 70%RH	Input Power	120Vac, 60Hz
Tested By	Noah Chang		

Antenna Polarity & Test Distance: Horizontal at 3 M							
No.	Freq. (MHz)	Reading (dBm)	S.G Power Value (dBm)	Correction Factor (dB)	EIRP (dBm)	Limit (dBm)	Margin (dB)
1	3720.00	-72.50	-66.30	7.10	-59.20	-13.00	-46.20
Antenna Polarity & Test Distance: Vertical at 3 M							
No.	Freq. (MHz)	Reading (dBm)	S.G Power Value (dBm)	Correction Factor (dB)	EIRP (dBm)	Limit (dBm)	Margin (dB)
1	3720.00	-75.40	-68.20	7.10	-61.10	-13.00	-48.10

Remarks:

1. EIRP (dBm) = S.G Value (dBm) + Correction Factor (dB).
2. Correction Factor (dB) = Substitution Antenna Gain (dB) + Cable Loss (dB).

Mode	TX channel 18900 (1880.00MHz)	Frequency Range	1GHz ~ 20GHz
Environmental Conditions	25deg. C, 70%RH	Input Power	120Vac, 60Hz
Tested By	Noah Chang		

Antenna Polarity & Test Distance: Horizontal at 3 M							
No.	Freq. (MHz)	Reading (dBm)	S.G Power Value (dBm)	Correction Factor (dB)	EIRP (dBm)	Limit (dBm)	Margin (dB)
1	3760.00	-73.40	-66.90	7.10	-59.80	-13.00	-46.80
Antenna Polarity & Test Distance: Vertical at 3 M							
No.	Freq. (MHz)	Reading (dBm)	S.G Power Value (dBm)	Correction Factor (dB)	EIRP (dBm)	Limit (dBm)	Margin (dB)
1	3760.00	-75.60	-68.20	7.10	-61.10	-13.00	-48.10

Remarks:

1. EIRP (dBm) = S.G Value (dBm) + Correction Factor (dB).
2. Correction Factor (dB) = Substitution Antenna Gain (dB) + Cable Loss (dB).

Mode	TX channel 19100 (1900.00MHz)	Frequency Range	1GHz ~ 20GHz
Environmental Conditions	25deg. C, 70%RH	Input Power	120Vac, 60Hz
Tested By	Noah Chang		

Antenna Polarity & Test Distance: Horizontal at 3 M							
No.	Freq. (MHz)	Reading (dBm)	S.G Power Value (dBm)	Correction Factor (dB)	EIRP (dBm)	Limit (dBm)	Margin (dB)
1	3800.00	-72.70	-65.80	7.10	-58.70	-13.00	-45.70
Antenna Polarity & Test Distance: Vertical at 3 M							
No.	Freq. (MHz)	Reading (dBm)	S.G Power Value (dBm)	Correction Factor (dB)	EIRP (dBm)	Limit (dBm)	Margin (dB)
1	3800.00	-75.20	-67.50	7.10	-60.40	-13.00	-47.40

Remarks:

1. EIRP (dBm) = S.G Value (dBm) + Correction Factor (dB).
2. Correction Factor (dB) = Substitution Antenna Gain (dB) + Cable Loss (dB).

## 5 Pictures of Test Arrangements

Please refer to the attached file (Test Setup Photo).

## Appendix – Information of the Testing Laboratories

We, Bureau Veritas Consumer Products Services (H.K.) Ltd., Taoyuan Branch, were founded in 1988 to provide our best service in EMC, Radio, Telecom and Safety consultation. Our laboratories are FCC recognized accredited test firms and accredited and approved according to ISO/IEC 17025.

If you have any comments, please feel free to contact us at the following:

### Lin Kou EMC/RF Lab

Tel: 886-2-26052180

Fax: 886-2-26051924

### Hsin Chu EMC/RF/Telecom Lab

Tel: 886-3-6668565

Fax: 886-3-6668323

### Hwa Ya EMC/RF/Safety Lab

Tel: 886-3-3183232

Fax: 886-3-3270892

**Email:** [service.adt@tw.bureauveritas.com](mailto:service.adt@tw.bureauveritas.com)

**Web Site:** [www.bureauveritas-adt.com](http://www.bureauveritas-adt.com)

The address and road map of all our labs can be found in our web site also.

--- END ---