



Appendix D - WCDMA Test Mode

Conducted Output Power

The EUT's WCDMA and HSDPA function is Release 5 version. A detailed analysis of the output power for all WCDMA modes is provided in the table below. The EUT supports DPDCH1 and HSDPA with several of data rates, such as 12.2Kbps, 64kbps, 144Kbps and 384Kbps.

<Model : ZX1>

Mode	Symbol Rates (Kbps)	SF	K	Data	Reference Channel Type (Data Rates)	Band II			Band V		
						Ch 9262	Ch 9400	Ch 9538	Ch 4132	Ch 4182	Ch 4233
						1852.4	1880.0	1907.6	826.4	836.4	846.6
DPDCH1	60	64	2	40	RMC 12.2 Kbps	22.35	22.20	22.27	22.75	22.54	22.71
	240	16	4	160	RMC 64 Kbps	22.67	22.94	22.78	22.80	22.63	22.81
	480	8	5	320	RMC 144 Kbps	22.26	22.21	22.22	22.76	22.52	22.73
	960	4	6	640	RMC 384 Kbps	22.23	22.19	22.24	22.76	22.53	22.73
HSDPA	60	64	2	40	RMC 12.2 Kbps	21.50	21.72	21.39	21.78	21.61	21.67

Data: Bits/Slot; SF: Spreading Factor; K: Number of bits per uplink DPDCH slot.

Table 1 Conducted output power for ZX1

<Model : P560>

Mode	Symbol Rates (Kbps)	SF	K	Data	Reference Channel Type (Data Rates)	Band II			Band V		
						Ch 9262	Ch 9400	Ch 9538	Ch 4132	Ch 4182	Ch 4233
						1852.4	1880.0	1907.6	826.4	836.4	846.6
DPDCH1	60	64	2	40	RMC 12.2 Kbps	22.24	22.69	22.60	22.81	22.80	22.72
	240	16	4	160	RMC 64 Kbps	22.27	22.71	22.57	22.77	22.81	22.70
	480	8	5	320	RMC 144 Kbps	22.25	22.68	22.61	22.79	22.80	22.69
	960	4	6	640	RMC 384 Kbps	22.30	22.72	22.58	22.80	22.78	22.69
HSDPA	60	64	2	40	RMC 12.2 Kbps	21.16	21.49	21.23	21.70	21.64	21.68

Data: Bits/Slot; SF: Spreading Factor; K: Number of bits per uplink DPDCH slot.

Table 2 Conducted output power for P560

Followed by FCC suggestions [1]:

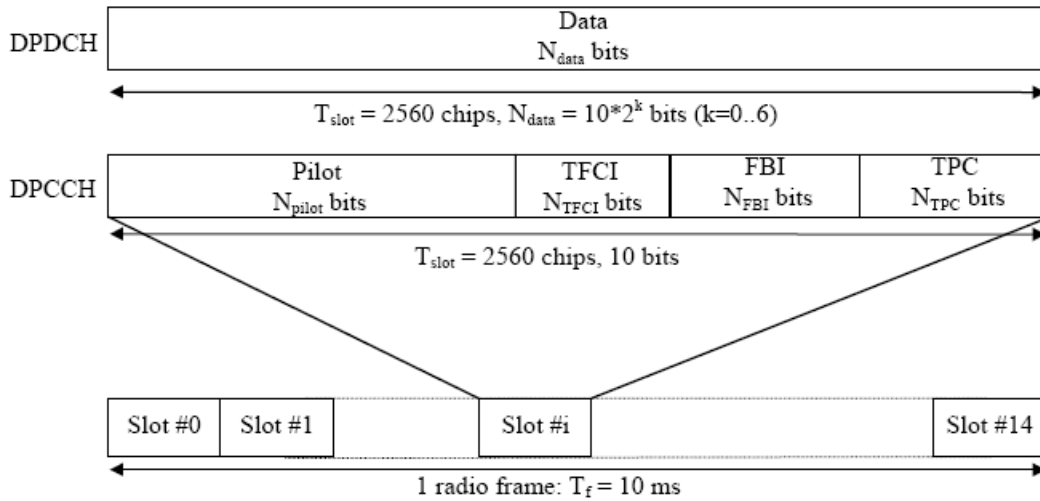

Frame structure for uplink DPDCH/DPCCH

The parameter K in the figure determines the number of bits per uplink DPDCH slot. It is related to the spreading factor SF of the DPDCH as $SF = 256/2^k$. The DPDCH spreading factor may range from 256 down to 4. The spreading factor of the uplink DPCCH is always equal to 256, i.e. there are 10 bits per uplink DPCCH slot.

	Channel Bit Rate (kbps)	Channel Symbol Rate (ksps)	Spreading Factor	Spreading Code Number	Bits/Slot
DPCCH	15	15	256	0	10
DPDCH ₁	15	15	256	64	10
	30	30	128	32	20
	60	60	64	16	40
	120	120	32	8	80
	240	240	16	4	160
	480	480	8	2	320
960	960	4	1	640	
DPDCH _n	960	960	4	1, 2, 3	640

Table 2 DPCCH and DPDCH

There is only one DPCCH per radio link. Data rates, channelization codes and spread factor information for DPCCH and DPDCH_n are indicated in the following Table. Spreading Rate (SF) * Symbol Rate = 3.84 Mcps.

WCDMA Setup Configuration

- a. The EUT was connected to Base Station. Refer to the drawing of Setup Configuration.
- b. The RF path losses were compensated into the measurements.
- c. A call was established between EUT and Base Station with following setting
 - i. Data rates: Varied RMC for each measurement.
 - ii. TPC with All Up
- d. The transmitted maximum output power was recorded.

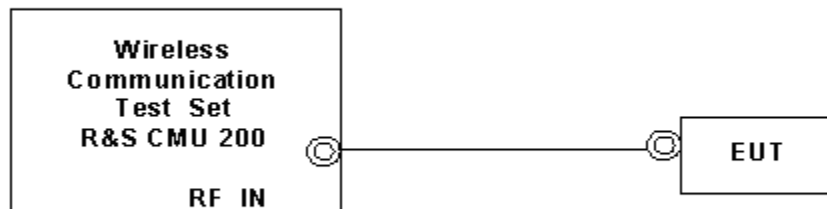

Setup Configuration

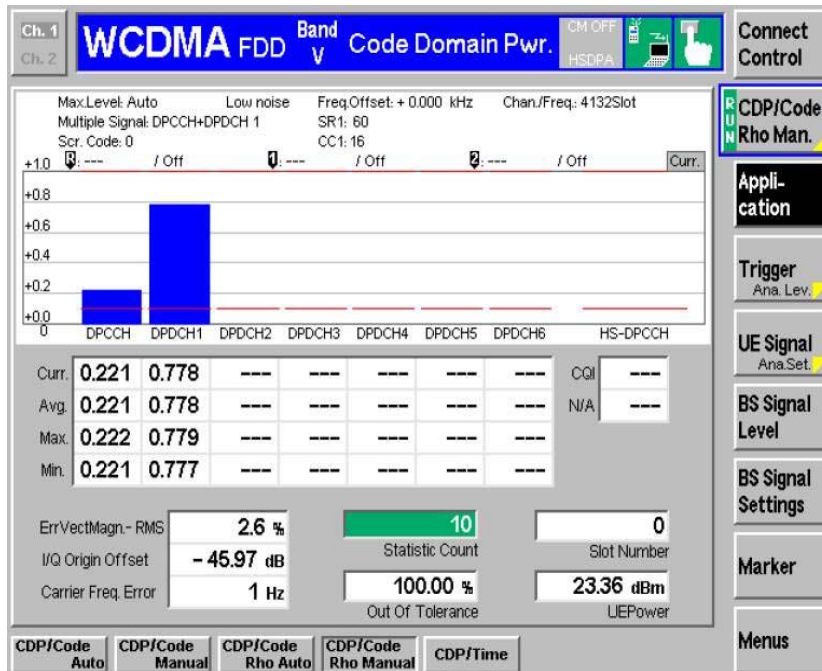

Single DPCCH with only one DPDCH at RMC 12.2Kbps (Symbol Rate 60 Kbps)

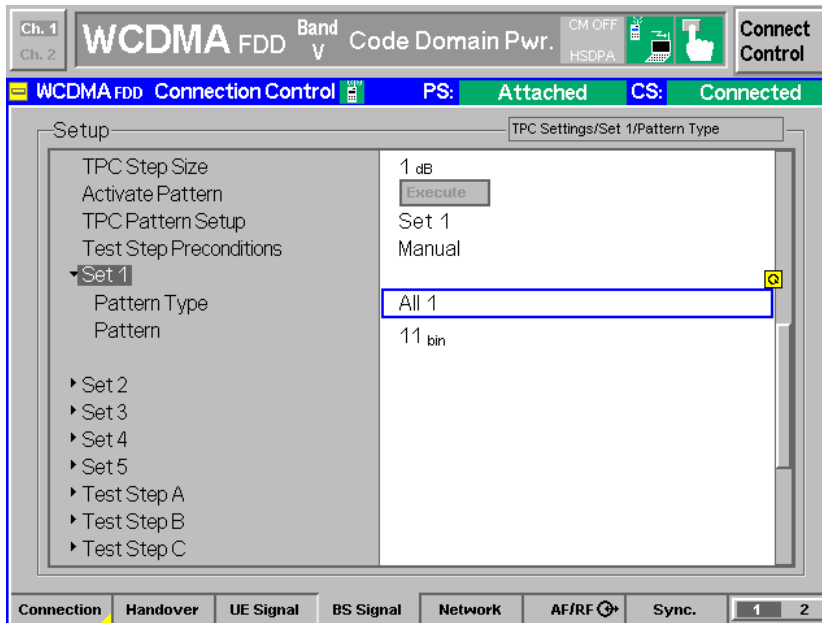

TPC with All "1" (Continuous transmitting)

HSDPA Setup Configuration

- a. The EUT was connected to Spectrum Analyzer and Base Station via power splitter. Refer to the drawing of Setup Configuration.
- b. The RF path losses were compensated into the measurements.
- c. A call was established between EUT and Base Station with following setting:
 - i. Set RMC12.2Kbps with HSDPA mode.
 - ii. TPC with All Up with H-set.
- d. The transmitted maximum output power was recorded.

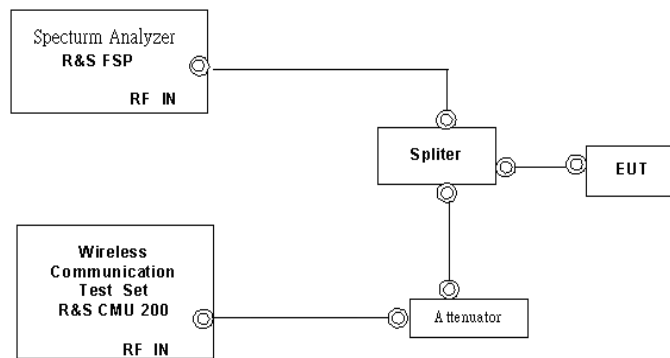

Setup Configuration

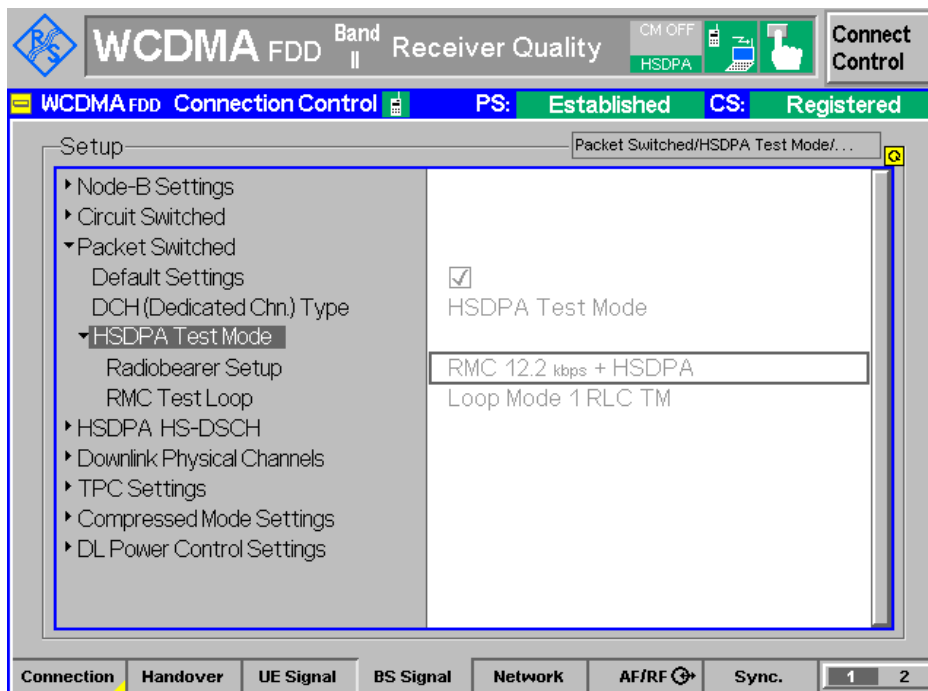

RMC 12.2Kbps with HSDPA function



Reference:

- [1.] SAR Measurement Procedures for 3G Devices CDMA 2000/Ev-Do/WCDMA/HSDPA June 2006 Laboratory Division Office of Engineering and Technology Federal Communications Commission
- [2.] TS 34.121 Universal Mobile Telecommunications System (UMTS); Terminal Conformance Specification, Radio Transmission and Reception (FDD)

Appendix E - Product Photos

Model : ZX1

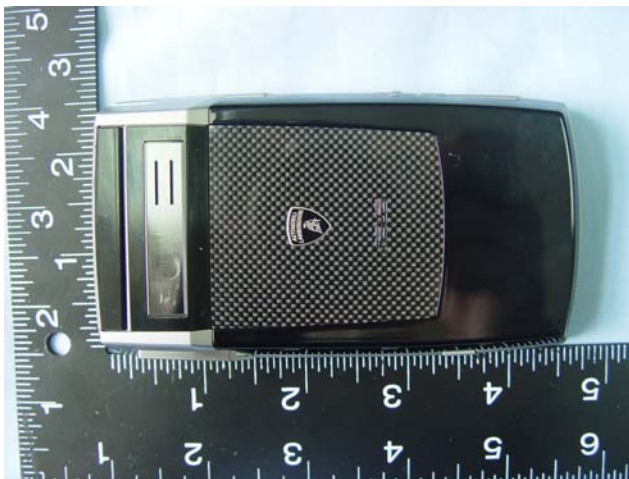

Model : P560



Battery 1

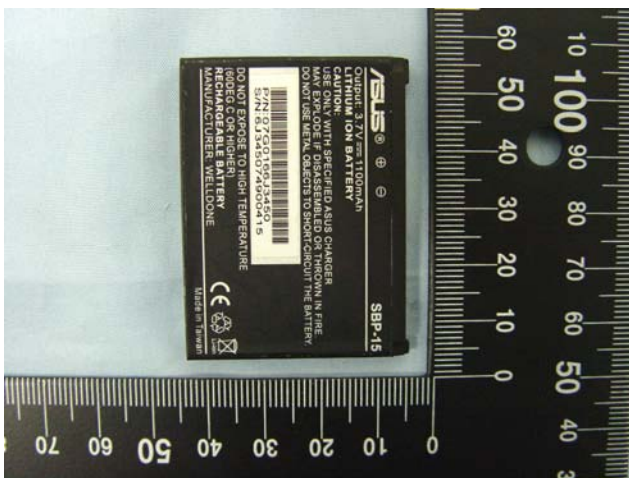
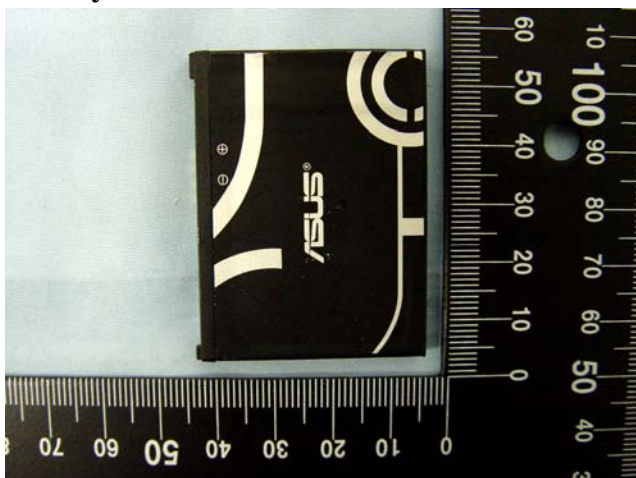

Battery 2

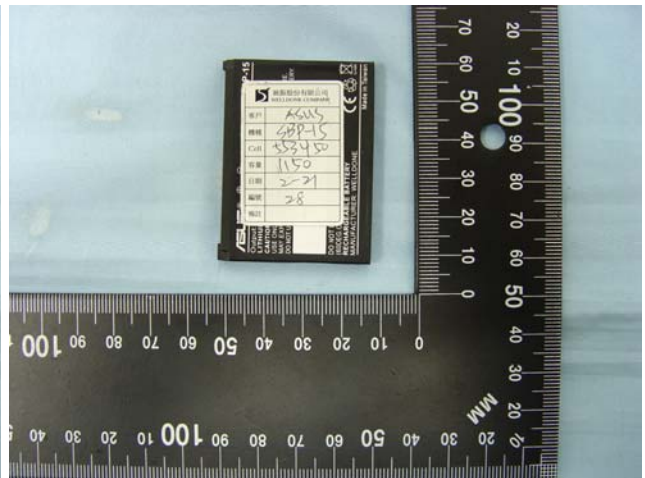
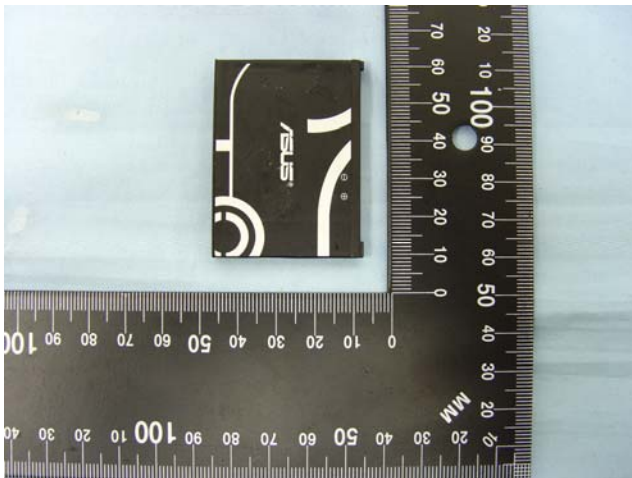

Earphone



Antenna Distance

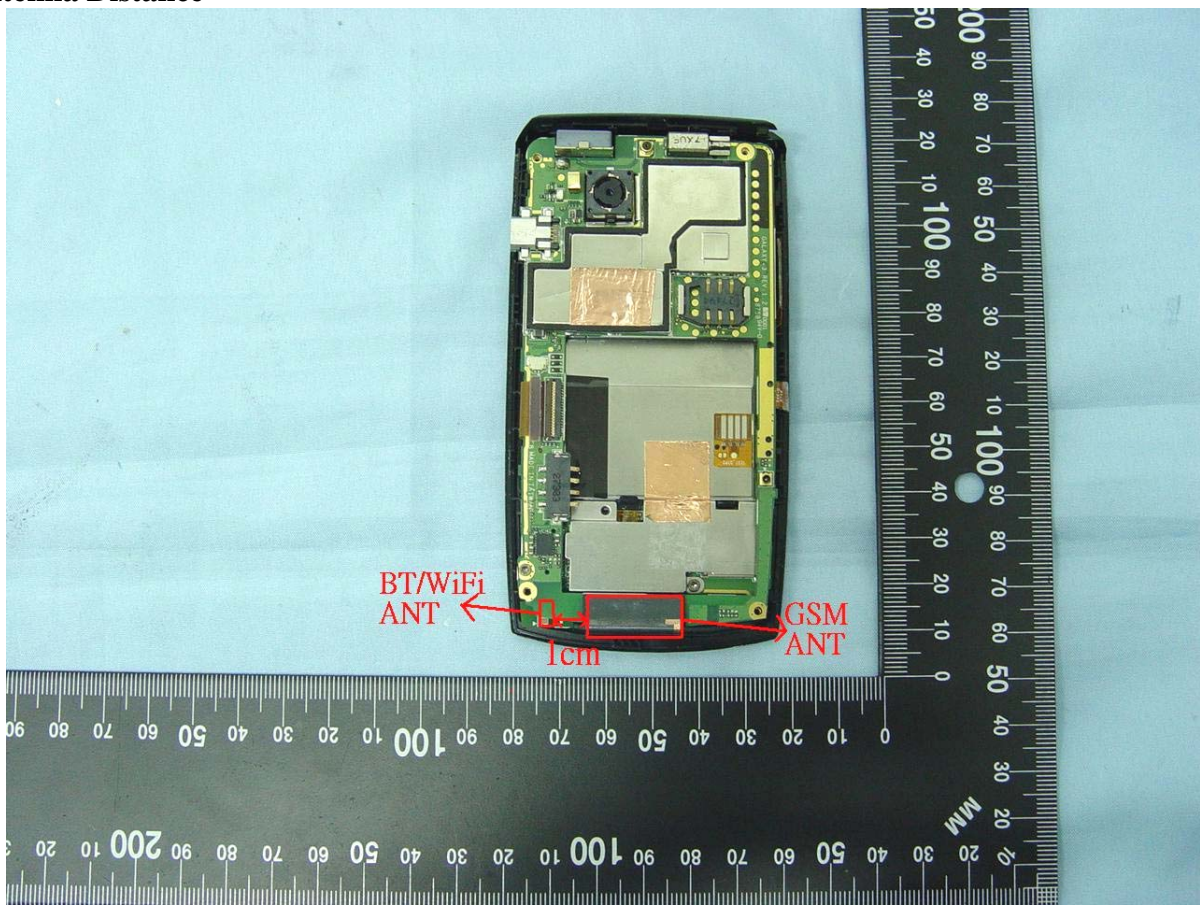

Appendix F - Test Setup Photos

Model : ZX1

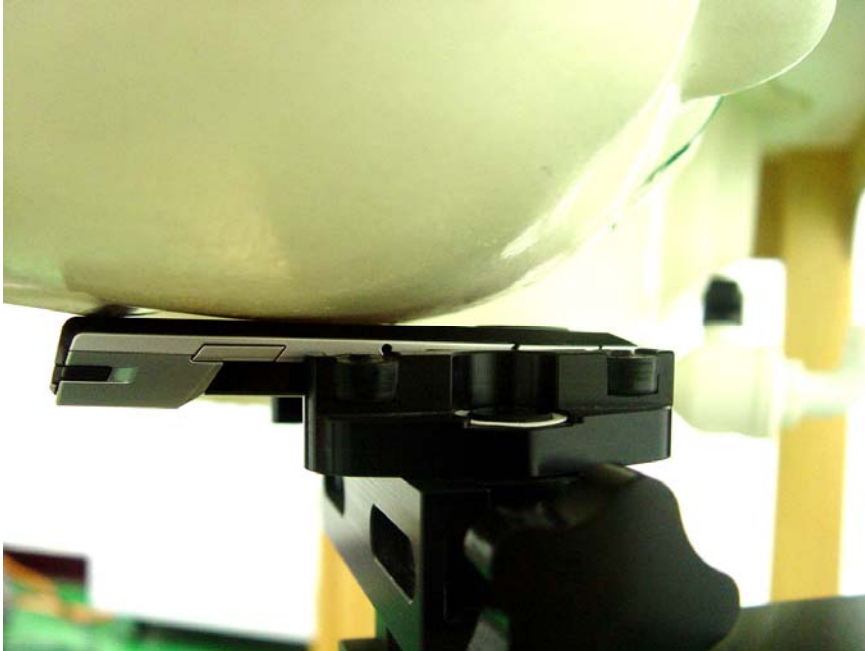

Right Cheek

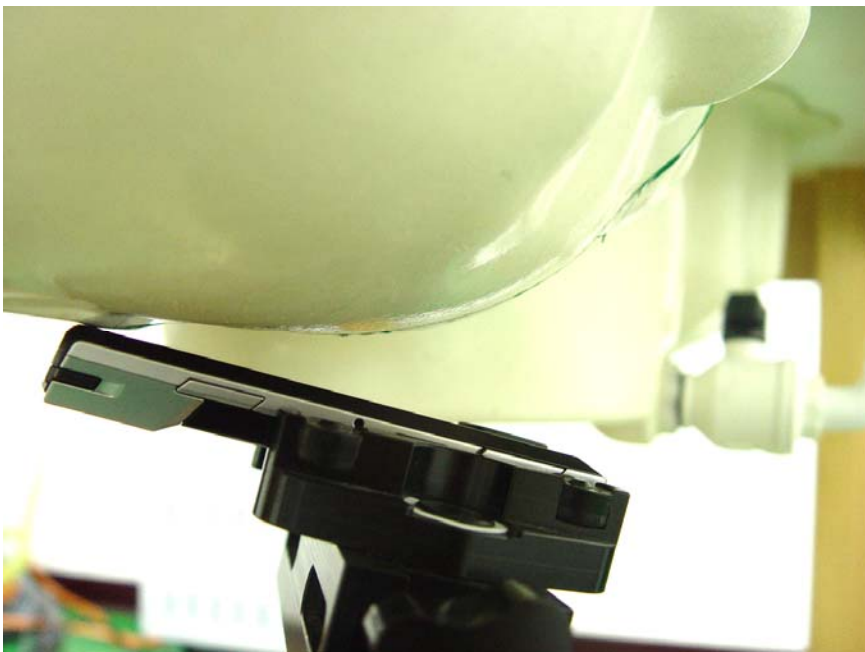

Right Tilted

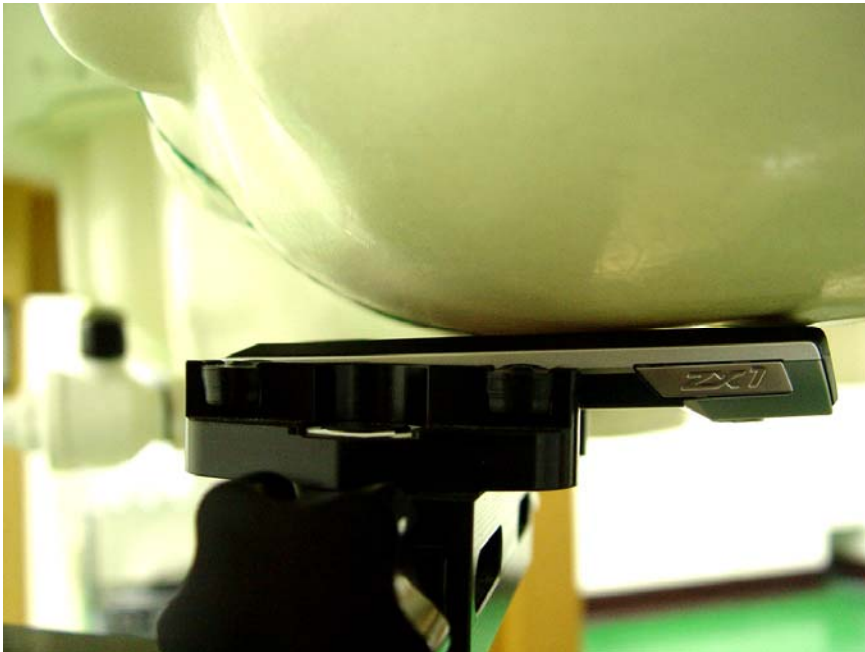

Left Cheek

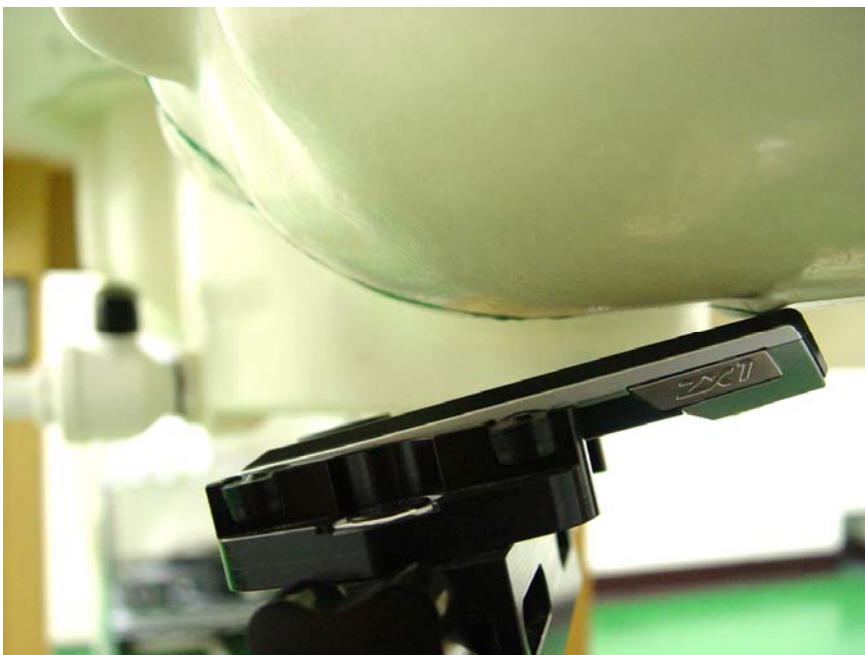

Left Tilted



Front Face With 1.5cm Gap

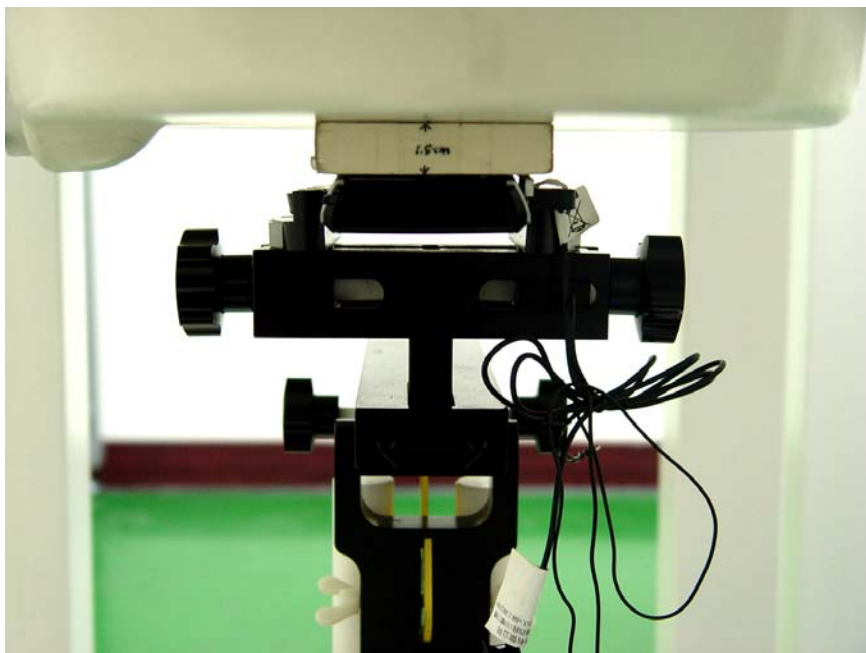

Rear Face With 1.5cm Gap

Model : P560

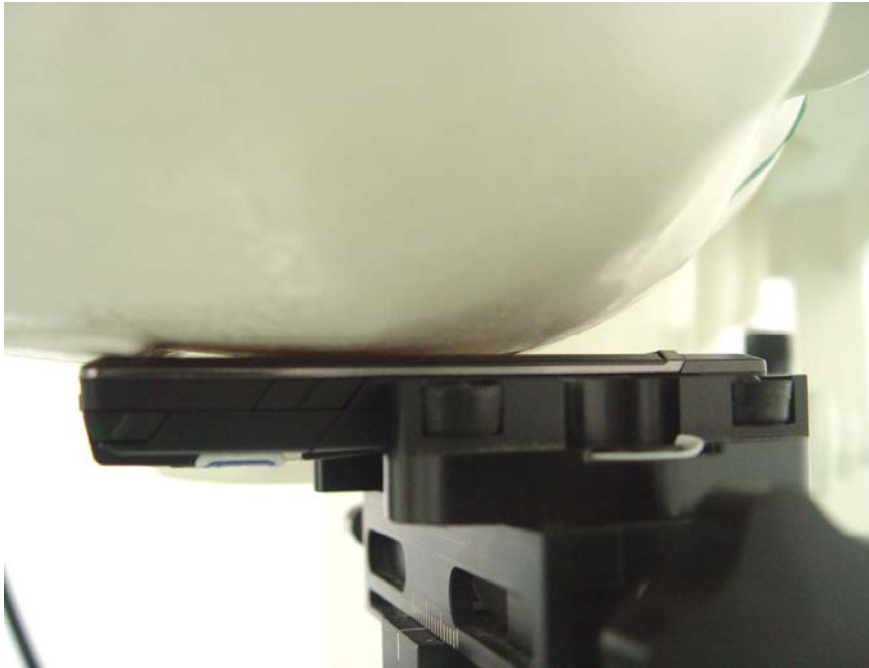

Right Cheek

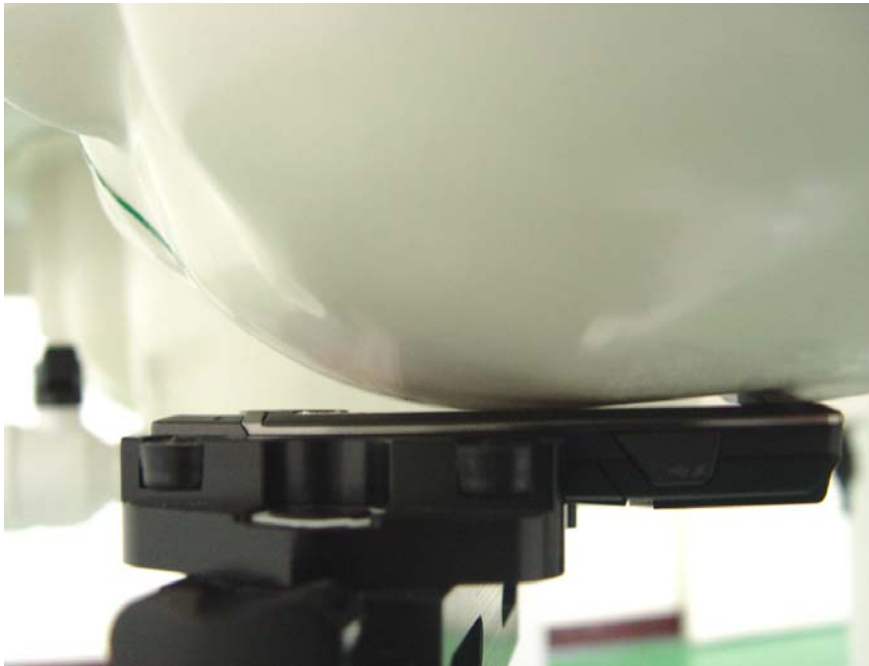

Left Cheek



Rear Face With 1.5cm Gap