

## Plots of System Verification

---

### Annex A. Plots of System Verification

The plots for system verification are shown as follows.

## Plots of System Verification

Test Laboratory: Bureau Veritas ADT SAR/HAC Testing Lab

Date: 2022/3/24

### S01 System Check\_H1900\_220324

DUT: Dipole 1900 MHz; Type: D1900V2; SN: 5d036

Communication System: UID 0, CW; Frequency: 1900 MHz; Duty Cycle: 1:1

Medium: H16T20N1\_0324 Medium parameters used:  $f = 1900$  MHz;  $\sigma = 1.463$  S/m;  $\epsilon_r = 38.787$ ;  $\rho = 1000$  kg/m<sup>3</sup>

Ambient Temperature : 23.7 °C ; Liquid Temperature : 23.3 °C

DASY5 Configuration:

- Probe: EX3DV4 - SN3578; ConvF(7.82, 7.82, 7.82) @ 1900 MHz; Calibrated: 2021/6/23
- Sensor-Surface: 1.4mm (Mechanical Surface Detection)
- Electronics: DAE4 Sn915; Calibrated: 2021/6/2
- Phantom: ELI Phantom\_1204; Type: QD OVA 002 Ax;
- Measurement SW: DASY52, Version 52.10 (4); SEMCAD X Version 14.6.14 (7501)

**Pin=50mW/Area Scan (61x61x1):** Interpolated grid: dx=1.500 mm, dy=1.500 mm

Maximum value of SAR (interpolated) = 3.290 W/kg

**Pin=50mW/Zoom Scan (5x5x7)/Cube 0:** Measurement grid: dx=8mm, dy=8mm, dz=5mm

Reference Value = 48.62 V/m; Power Drift = -0.02 dB

Peak SAR (extrapolated) = 4.01 W/kg

**SAR(1 g) = 2.02 W/kg; SAR(10 g) = 1.06 W/kg** (SAR corrected for target medium)

Maximum value of SAR (measured) = 3.31 W/kg

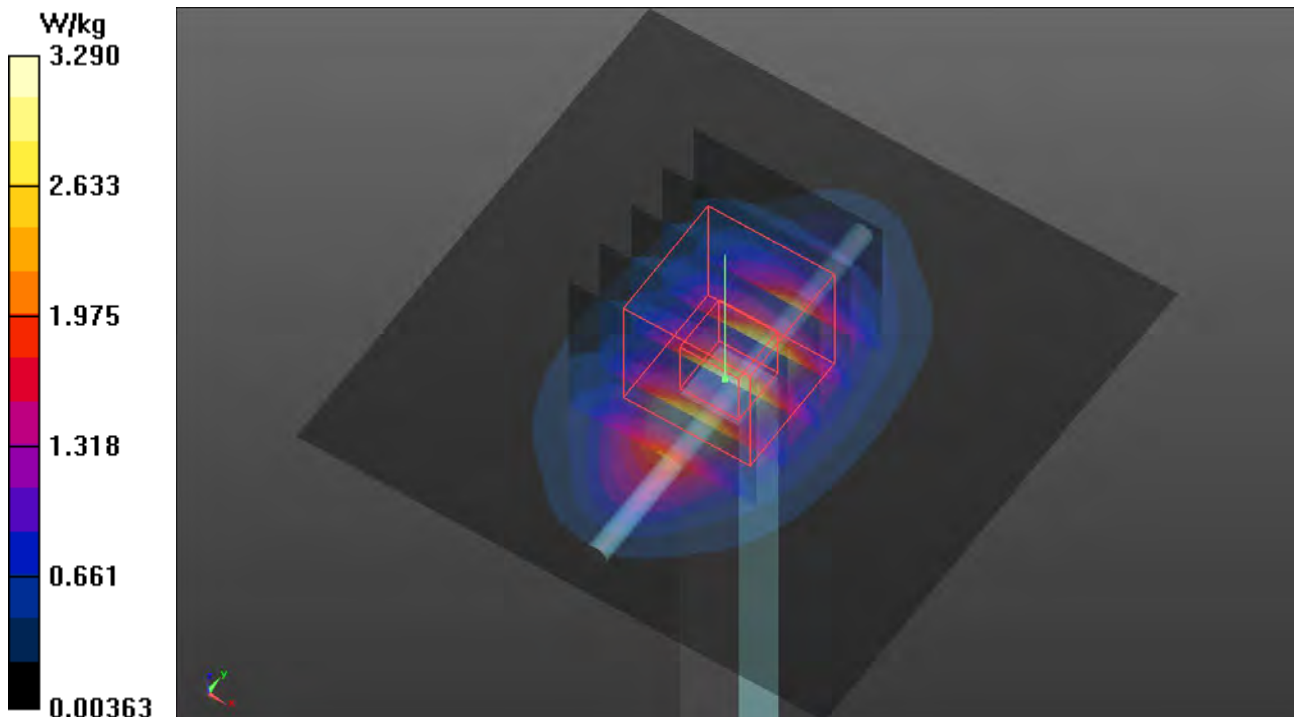

## Plots of System Verification

Test Laboratory: Bureau Veritas ADT SAR/HAC Testing Lab

Date: 2022/3/25

### S02 System Check\_H1750\_220325

DUT: Dipole 1750 MHz; Type: D1750V2; SN: 1055

Communication System: UID 0, CW; Frequency: 1750 MHz; Duty Cycle: 1:1

Medium: H16T20N1\_0325 Medium parameters used:  $f = 1750$  MHz;  $\sigma = 1.32$  S/m;  $\epsilon_r = 40.26$ ;  $\rho = 1000$  kg/m<sup>3</sup>

Ambient Temperature : 23.6 °C ; Liquid Temperature : 23.4 °C

DASY5 Configuration:

- Probe: EX3DV4 - SN3578; ConvF(8.09, 8.09, 8.09) @ 1750 MHz; Calibrated: 2021/6/23
- Sensor-Surface: 1.4mm (Mechanical Surface Detection)
- Electronics: DAE4 Sn915; Calibrated: 2021/6/2
- Phantom: ELI Phantom\_1204; Type: QD OVA 002 Ax;
- Measurement SW: DASY52, Version 52.10 (4); SEMCAD X Version 14.6.14 (7501)

**Pin=50mW/Area Scan (61x61x1):** Interpolated grid: dx=1.500 mm, dy=1.500 mm

Maximum value of SAR (interpolated) = 2.810 W/kg

**Pin=50mW/Zoom Scan (5x5x7)/Cube 0:** Measurement grid: dx=8mm, dy=8mm, dz=5mm

Reference Value = 47.07 V/m; Power Drift = -0.03 dB

Peak SAR (extrapolated) = 3.33 W/kg

**SAR(1 g) = 1.82 W/kg; SAR(10 g) = 0.954 W/kg** (SAR corrected for target medium)

Maximum value of SAR (measured) = 2.79 W/kg

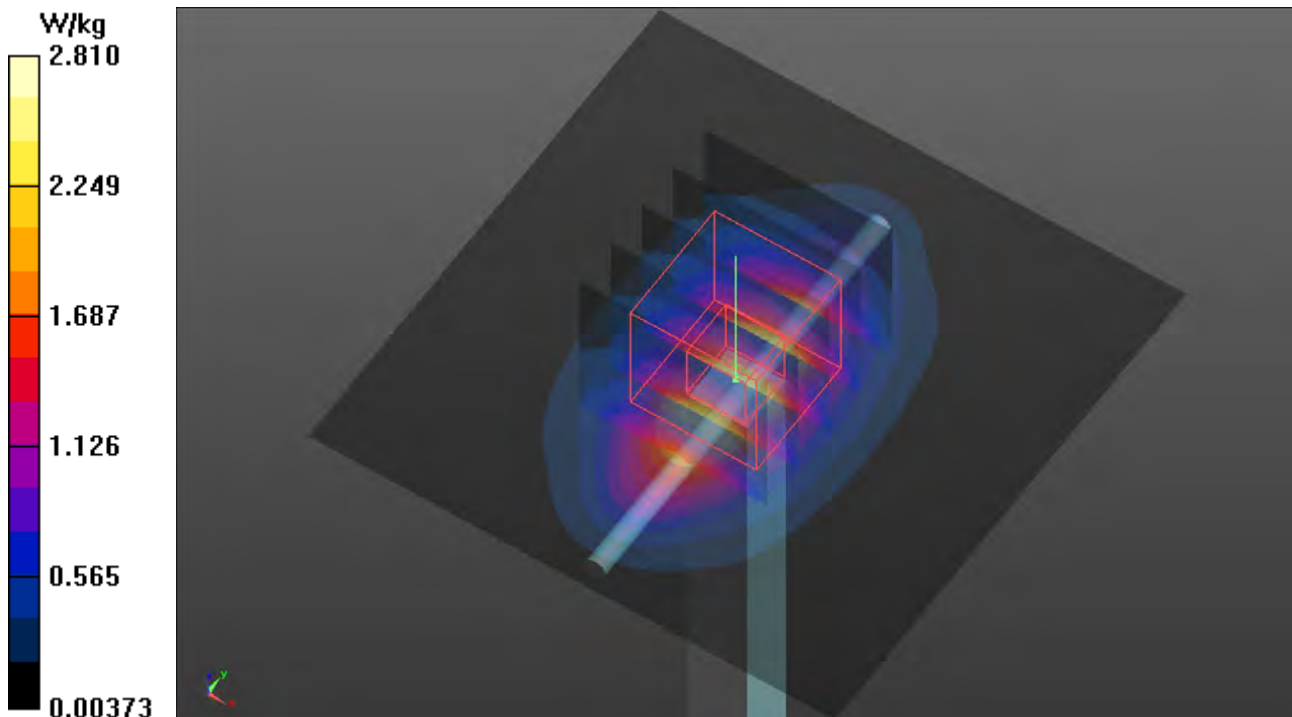

## Plots of System Verification

Test Laboratory: Bureau Veritas ADT SAR/HAC Testing Lab

Date: 2022/3/25

### S03 System Check\_H835\_220325

DUT: Dipole 835 MHz; Type: D835V2; SN: 4d121

Communication System: UID 0, CW; Frequency: 835 MHz; Duty Cycle: 1:1

Medium: H07T10N1\_0325 Medium parameters used:  $f = 835$  MHz;  $\sigma = 0.934$  S/m;  $\epsilon_r = 40.367$ ;  $\rho = 1000$  kg/m<sup>3</sup>

Ambient Temperature : 23.6 °C ; Liquid Temperature : 23.4 °C

DASY5 Configuration:

- Probe: EX3DV4 - SN3578; ConvF(9.54, 9.54, 9.54) @ 835 MHz; Calibrated: 2021/6/23
- Sensor-Surface: 1.4mm (Mechanical Surface Detection)
- Electronics: DAE4 Sn915; Calibrated: 2021/6/2
- Phantom: ELI Phantom\_1204; Type: QD OVA 002 Ax;
- Measurement SW: DASY52, Version 52.10 (4); SEMCAD X Version 14.6.14 (7501)

**Pin=50mW/Area Scan (61x61x1):** Interpolated grid: dx=1.500 mm, dy=1.500 mm  
Maximum value of SAR (interpolated) = 0.636 W/kg

**Pin=50mW/Zoom Scan (5x5x7)/Cube 0:** Measurement grid: dx=8mm, dy=8mm, dz=5mm

Reference Value = 27.37 V/m; Power Drift = 0.02 dB

Peak SAR (extrapolated) = 0.714 W/kg

**SAR(1 g) = 0.461 W/kg; SAR(10 g) = 0.302 W/kg** (SAR corrected for target medium)

Maximum value of SAR (measured) = 0.634 W/kg

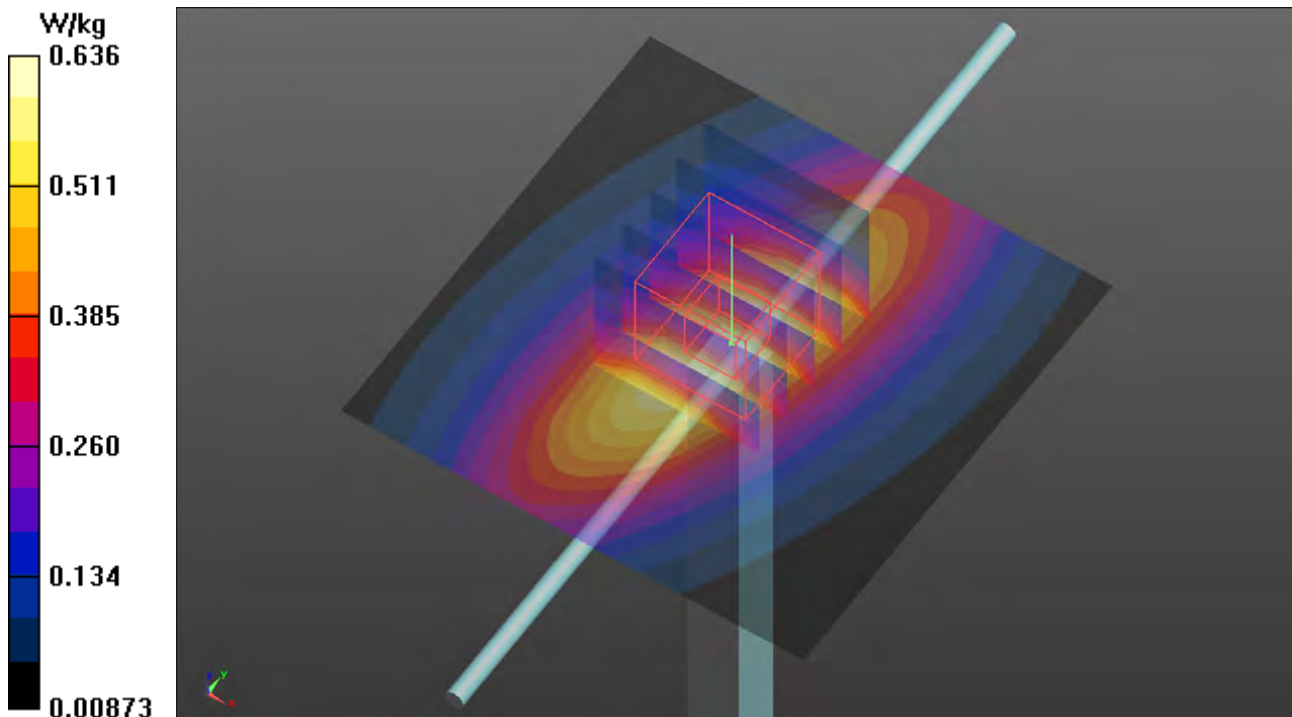

## Plots of System Verification

Test Laboratory: Bureau Veritas ADT SAR/HAC Testing Lab

Date: 2022/3/24

### S04 System Check\_H1900\_220324

DUT: Dipole 1900 MHz; Type: D1900V2; SN: 5d036

Communication System: UID 0, CW; Frequency: 1900 MHz; Duty Cycle: 1:1

Medium: H16T20N1\_0324 Medium parameters used:  $f = 1900$  MHz;  $\sigma = 1.463$  S/m;  $\epsilon_r = 38.787$ ;  $\rho = 1000$  kg/m<sup>3</sup>

Ambient Temperature : 23.7 °C ; Liquid Temperature : 23.3 °C

DASY5 Configuration:

- Probe: EX3DV4 - SN3578; ConvF(7.82, 7.82, 7.82) @ 1900 MHz; Calibrated: 2021/6/23
- Sensor-Surface: 1.4mm (Mechanical Surface Detection)
- Electronics: DAE4 Sn915; Calibrated: 2021/6/2
- Phantom: ELI Phantom\_1204; Type: QD OVA 002 Ax;
- Measurement SW: DASY52, Version 52.10 (4); SEMCAD X Version 14.6.14 (7501)

**Pin=50mW/Area Scan (61x61x1):** Interpolated grid: dx=1.500 mm, dy=1.500 mm

Maximum value of SAR (interpolated) = 3.290 W/kg

**Pin=50mW/Zoom Scan (5x5x7)/Cube 0:** Measurement grid: dx=8mm, dy=8mm, dz=5mm

Reference Value = 48.62 V/m; Power Drift = -0.02 dB

Peak SAR (extrapolated) = 4.01 W/kg

**SAR(1 g) = 2.02 W/kg; SAR(10 g) = 1.06 W/kg** (SAR corrected for target medium)

Maximum value of SAR (measured) = 3.31 W/kg

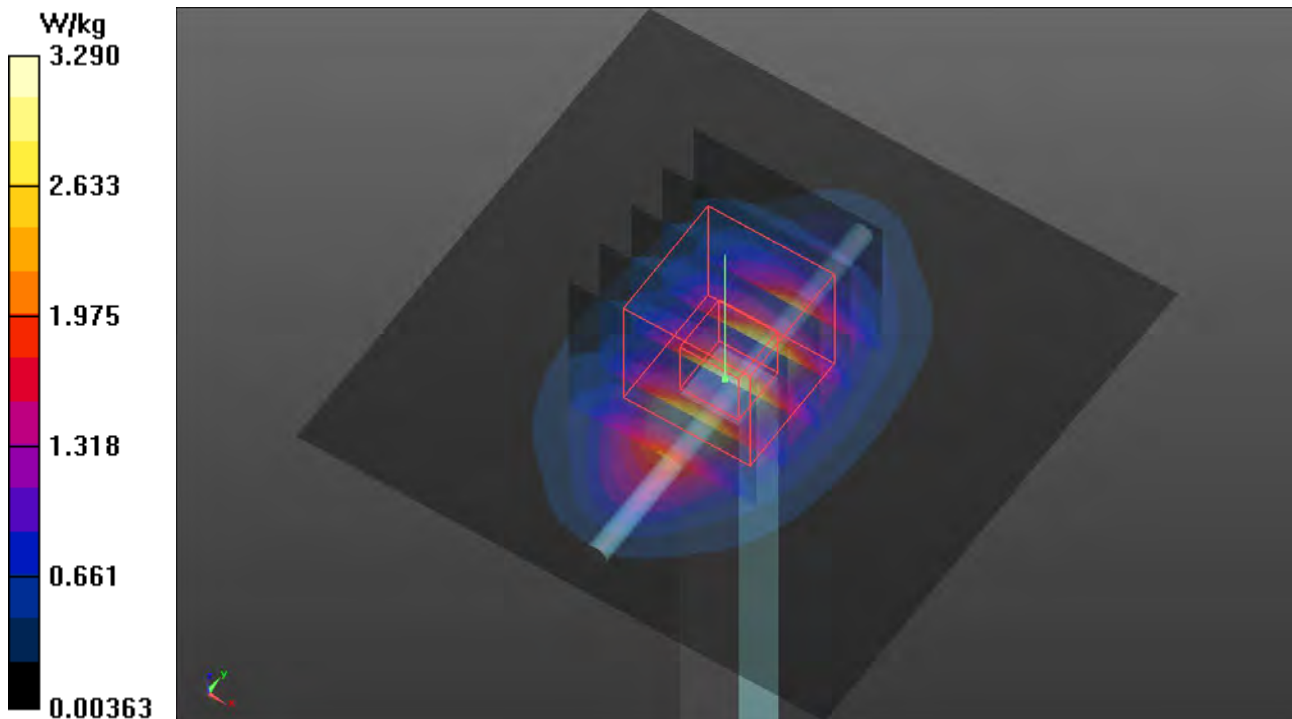

## Plots of System Verification

Test Laboratory: Bureau Veritas ADT SAR/HAC Testing Lab

Date: 2022/3/25

### S05 System Check\_H1750\_220325

DUT: Dipole 1750 MHz; Type: D1750V2; SN: 1055

Communication System: UID 0, CW; Frequency: 1750 MHz; Duty Cycle: 1:1

Medium: H16T20N1\_0325 Medium parameters used:  $f = 1750$  MHz;  $\sigma = 1.32$  S/m;  $\epsilon_r = 40.26$ ;  $\rho = 1000$  kg/m<sup>3</sup>

Ambient Temperature : 23.6 °C ; Liquid Temperature : 23.4 °C

DASY5 Configuration:

- Probe: EX3DV4 - SN3578; ConvF(8.09, 8.09, 8.09) @ 1750 MHz; Calibrated: 2021/6/23
- Sensor-Surface: 1.4mm (Mechanical Surface Detection)
- Electronics: DAE4 Sn915; Calibrated: 2021/6/2
- Phantom: ELI Phantom\_1204; Type: QD OVA 002 Ax;
- Measurement SW: DASY52, Version 52.10 (4); SEMCAD X Version 14.6.14 (7501)

**Pin=50mW/Area Scan (61x61x1):** Interpolated grid:  $dx=1.500$  mm,  $dy=1.500$  mm

Maximum value of SAR (interpolated) = 2.810 W/kg

**Pin=50mW/Zoom Scan (5x5x7)/Cube 0:** Measurement grid:  $dx=8$ mm,  $dy=8$ mm,  $dz=5$ mm

Reference Value = 47.07 V/m; Power Drift = -0.03 dB

Peak SAR (extrapolated) = 3.33 W/kg

**SAR(1 g) = 1.82 W/kg; SAR(10 g) = 0.954 W/kg** (SAR corrected for target medium)

Maximum value of SAR (measured) = 2.79 W/kg

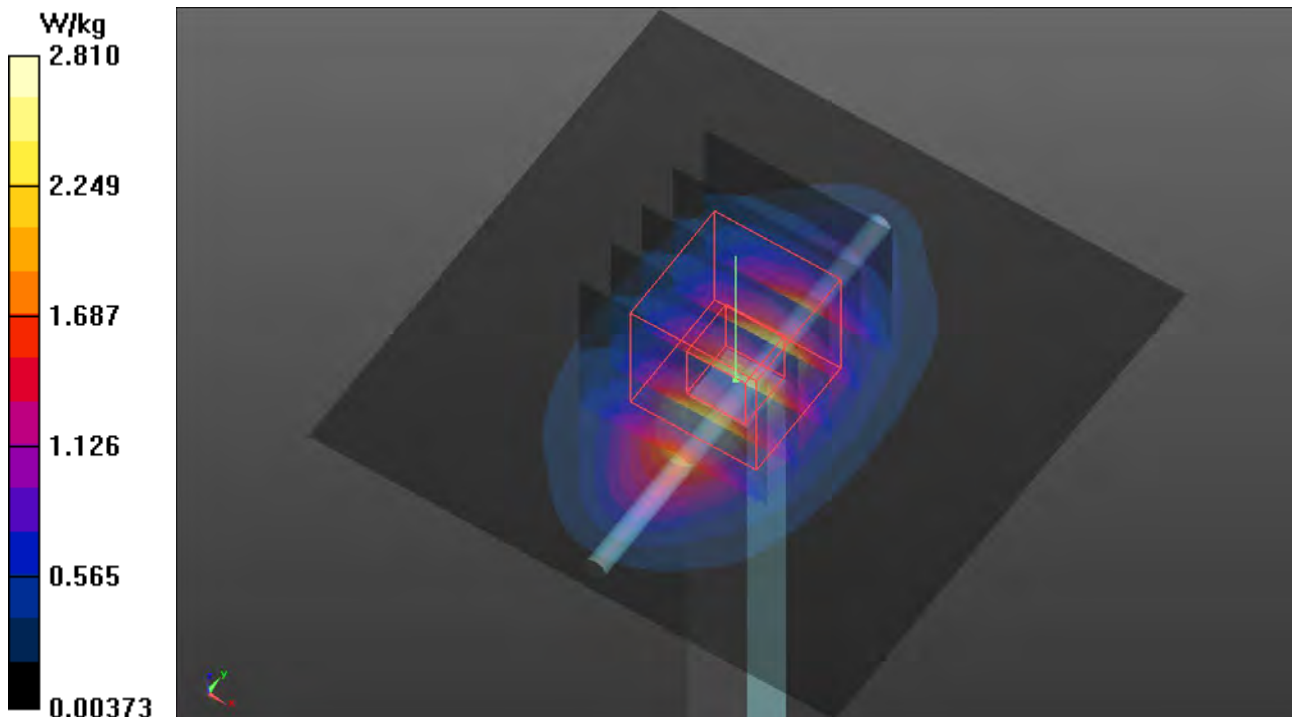

## Plots of System Verification

Test Laboratory: Bureau Veritas ADT SAR/HAC Testing Lab

Date: 2022/3/25

### S06 System Check\_H835\_220325

DUT: Dipole 835 MHz; Type: D835V2; SN: 4d121

Communication System: UID 0, CW; Frequency: 835 MHz; Duty Cycle: 1:1

Medium: H07T10N1\_0325 Medium parameters used:  $f = 835$  MHz;  $\sigma = 0.934$  S/m;  $\epsilon_r = 40.367$ ;  $\rho = 1000$  kg/m<sup>3</sup>

Ambient Temperature : 23.6 °C ; Liquid Temperature : 23.4 °C

DASY5 Configuration:

- Probe: EX3DV4 - SN3578; ConvF(9.54, 9.54, 9.54) @ 835 MHz; Calibrated: 2021/6/23
- Sensor-Surface: 1.4mm (Mechanical Surface Detection)
- Electronics: DAE4 Sn915; Calibrated: 2021/6/2
- Phantom: ELI Phantom\_1204; Type: QD OVA 002 Ax;
- Measurement SW: DASY52, Version 52.10 (4); SEMCAD X Version 14.6.14 (7501)

**Pin=50mW/Area Scan (61x61x1):** Interpolated grid: dx=1.500 mm, dy=1.500 mm

Maximum value of SAR (interpolated) = 0.636 W/kg

**Pin=50mW/Zoom Scan (5x5x7)/Cube 0:** Measurement grid: dx=8mm, dy=8mm, dz=5mm

Reference Value = 27.37 V/m; Power Drift = 0.02 dB

Peak SAR (extrapolated) = 0.714 W/kg

**SAR(1 g) = 0.461 W/kg; SAR(10 g) = 0.302 W/kg** (SAR corrected for target medium)

Maximum value of SAR (measured) = 0.634 W/kg

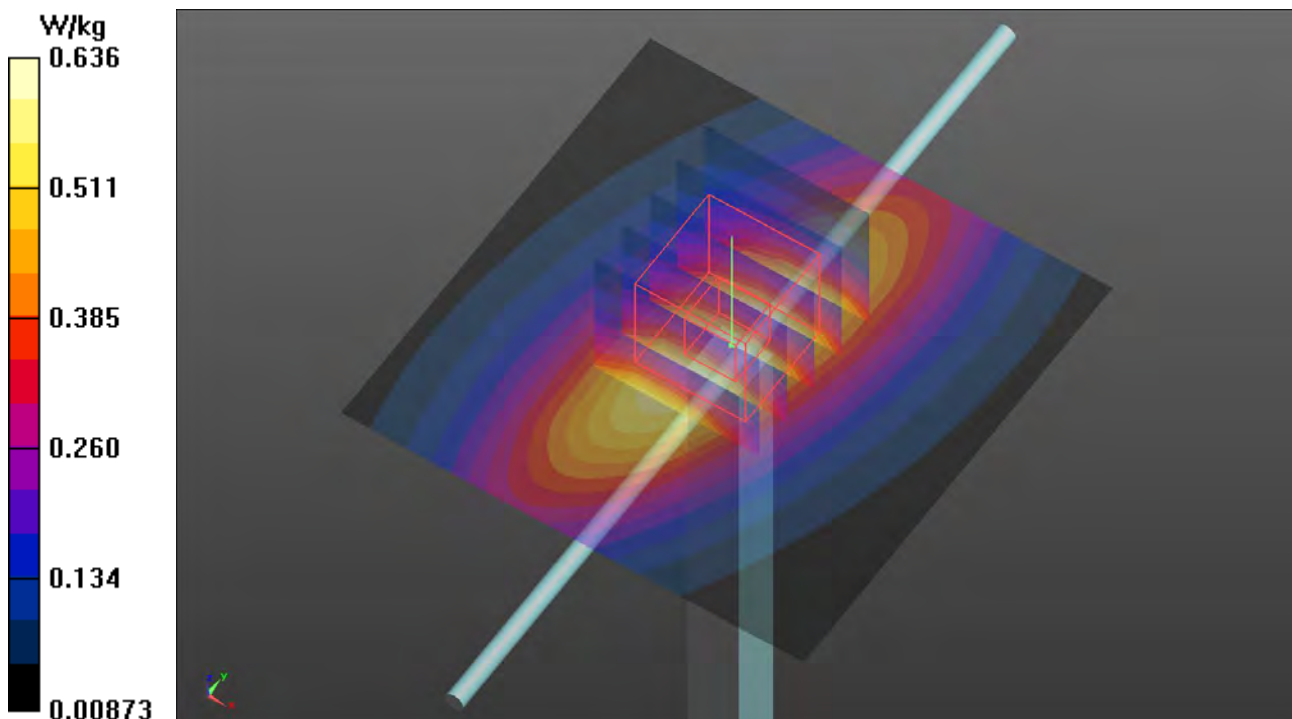

## Plots of System Verification

Test Laboratory: Bureau Veritas ADT SAR/HAC Testing Lab

Date: 2022/03/29

### S07 System Check\_H2600\_220329

**DUT: Dipole 2600 MHz; Type: D2600V2; SN: 1020**

Communication System: UID 0, CW; Frequency: 2600 MHz; Duty Cycle: 1:1

Medium: H19T27N3\_0329 Medium parameters used:  $f = 2600$  MHz;  $\sigma = 1.915$  S/m;  $\epsilon_r = 37.812$ ;  $\rho = 1000$  kg/m<sup>3</sup>

Ambient Temperature : 23.4 °C ; Liquid Temperature : 23.3 °C

DASY5 Configuration:

- Probe: EX3DV4 - SN3578; ConvF(7.22, 7.22, 7.22) @ 2600 MHz; Calibrated: 2021/06/23
- Sensor-Surface: 1.4mm (Mechanical Surface Detection)
- Electronics: DAE4 Sn915; Calibrated: 2021/06/02
- Phantom: ELI Phantom\_1043; Type: QD OVA 002 Ax
- Measurement SW: DASY52, Version 52.10 (4); SEMCAD X Version 14.6.14 (7501)

**Pin=50mW/Area Scan (81x81x1):** Interpolated grid: dx=1.200 mm, dy=1.200 mm

Maximum value of SAR (interpolated) = 4.69 W/kg

**Pin=50mW/Zoom Scan (7x7x7)/Cube 0:** Measurement grid: dx=5mm, dy=5mm, dz=5mm

Reference Value = 51.57 V/m; Power Drift = 0.05 dB

Peak SAR (extrapolated) = 5.84 W/kg

**SAR(1 g) = 2.75 W/kg; SAR(10 g) = 1.23 W/kg** (SAR corrected for target medium)

Maximum value of SAR (measured) = 4.68 W/kg

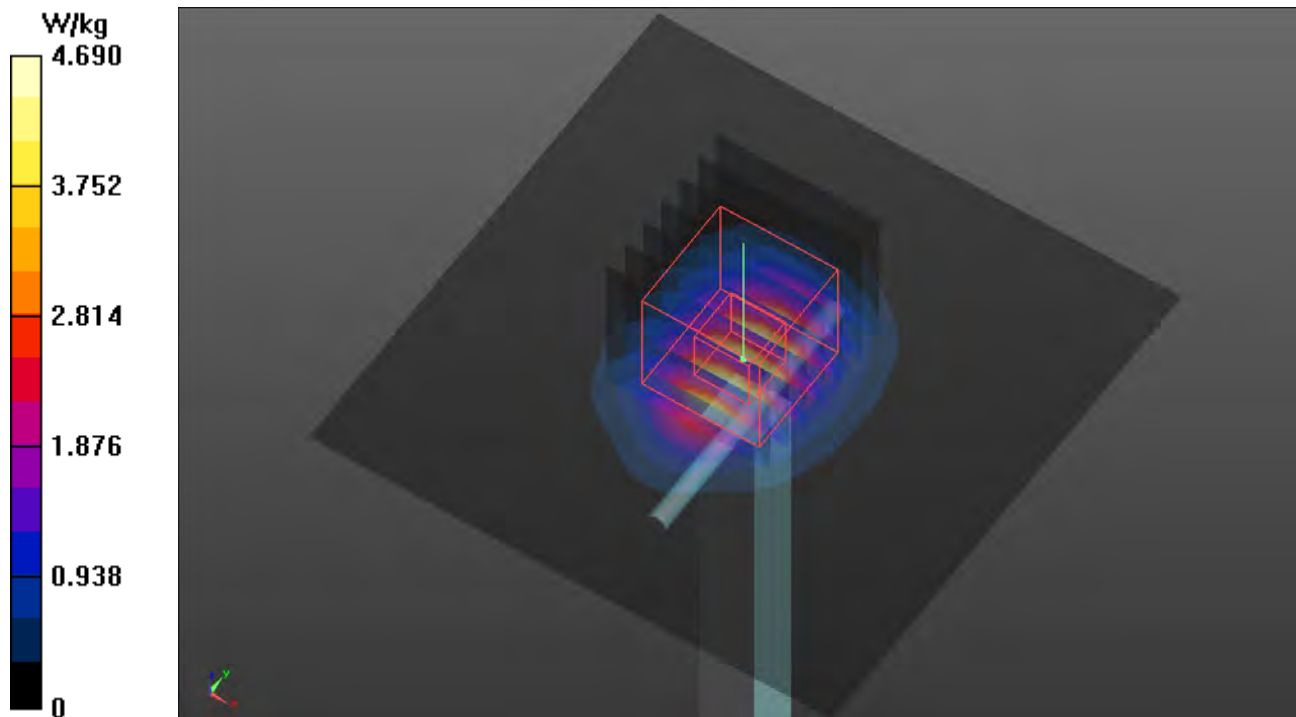



## Plots of System Verification

Test Laboratory: Bureau Veritas ADT SAR/HAC Testing Lab

Date: 2022/03/28

### S08 System Check\_H750\_220328

**DUT: Dipole 750 MHz; Type: D750V3; SN: 1013**

Communication System: UID 0, CW; Frequency: 750 MHz; Duty Cycle: 1:1

Medium: H06T09N1\_0328 Medium parameters used:  $f = 750$  MHz;  $\sigma = 0.902$  S/m;  $\epsilon_r = 41.582$ ;  $\rho = 1000$  kg/m<sup>3</sup>

Ambient Temperature : 23.8 °C ; Liquid Temperature : 23.4 °C

DASY5 Configuration:

- Probe: EX3DV4 - SN3578; ConvF(10.02, 10.02, 10.02) @ 750 MHz; Calibrated: 2021/06/23
- Sensor-Surface: 1.4mm (Mechanical Surface Detection)
- Electronics: DAE4 Sn915; Calibrated: 2021/06/02
- Phantom: ELI Phantom\_1043; Type: QD OVA 002 Ax
- Measurement SW: DASY52, Version 52.10 (4); SEMCAD X Version 14.6.14 (7501)

**Pin=50mW/Area Scan (61x61x1):** Interpolated grid:  $dx=1.500$  mm,  $dy=1.500$  mm

Maximum value of SAR (interpolated) = 0.581 W/kg

**Pin=50mW/Zoom Scan (5x5x7)/Cube 0:** Measurement grid:  $dx=8$ mm,  $dy=8$ mm,  $dz=5$ mm

Reference Value = 26.25 V/m; Power Drift = -0.01 dB

Peak SAR (extrapolated) = 0.657 W/kg

**SAR(1 g) = 0.438 W/kg; SAR(10 g) = 0.292 W/kg** (SAR corrected for target medium)

Maximum value of SAR (measured) = 0.586 W/kg

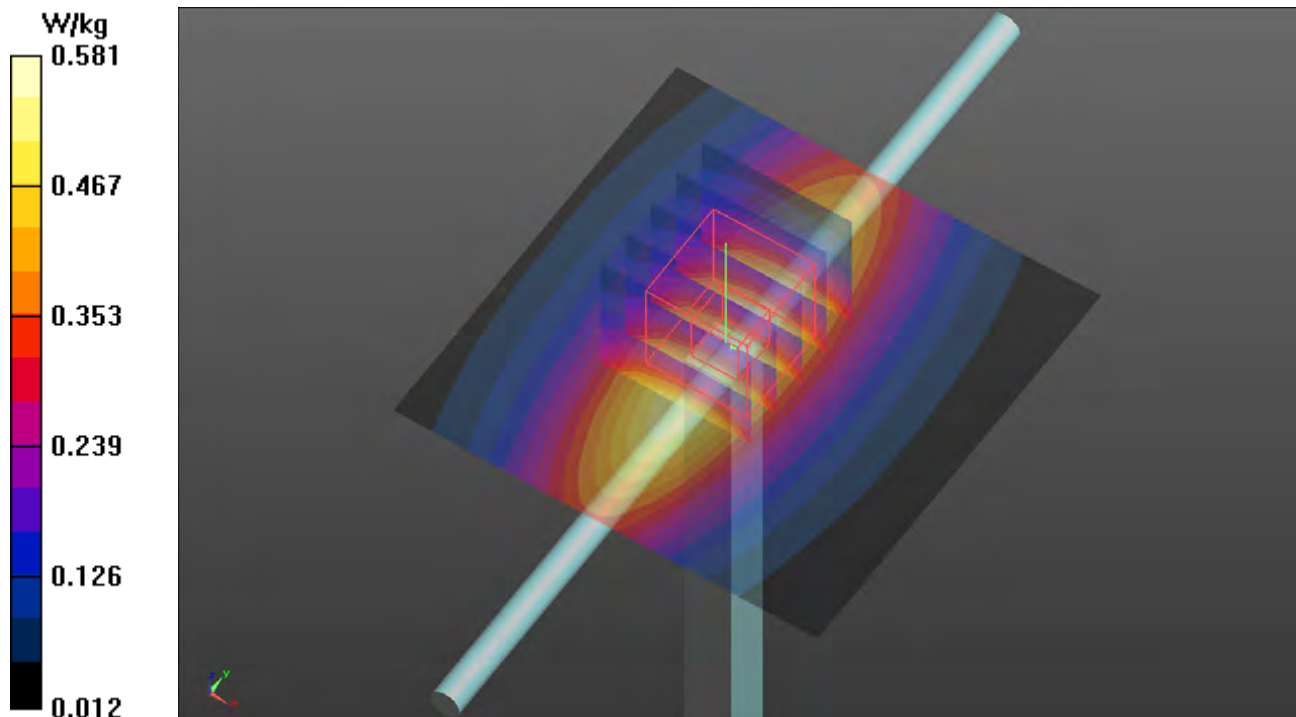

## Plots of System Verification

Test Laboratory: Bureau Veritas ADT SAR/HAC Testing Lab

Date: 2022/03/28

### S09 System Check\_H750\_220328

**DUT: Dipole 750 MHz; Type: D750V3; SN: 1013**

Communication System: UID 0, CW; Frequency: 750 MHz; Duty Cycle: 1:1

Medium: H06T09N1\_0328 Medium parameters used:  $f = 750$  MHz;  $\sigma = 0.902$  S/m;  $\epsilon_r = 41.582$ ;  $\rho = 1000$  kg/m<sup>3</sup>

Ambient Temperature : 23.8 °C ; Liquid Temperature : 23.4 °C

DASY5 Configuration:

- Probe: EX3DV4 - SN3578; ConvF(10.02, 10.02, 10.02) @ 750 MHz; Calibrated: 2021/06/23
- Sensor-Surface: 1.4mm (Mechanical Surface Detection)
- Electronics: DAE4 Sn915; Calibrated: 2021/06/02
- Phantom: ELI Phantom\_1043; Type: QD OVA 002 Ax
- Measurement SW: DASY52, Version 52.10 (4); SEMCAD X Version 14.6.14 (7501)

**Pin=50mW/Area Scan (61x61x1):** Interpolated grid: dx=1.500 mm, dy=1.500 mm

Maximum value of SAR (interpolated) = 0.581 W/kg

**Pin=50mW/Zoom Scan (5x5x7)/Cube 0:** Measurement grid: dx=8mm, dy=8mm, dz=5mm

Reference Value = 26.25 V/m; Power Drift = -0.01 dB

Peak SAR (extrapolated) = 0.657 W/kg

**SAR(1 g) = 0.438 W/kg; SAR(10 g) = 0.292 W/kg** (SAR corrected for target medium)

Maximum value of SAR (measured) = 0.586 W/kg

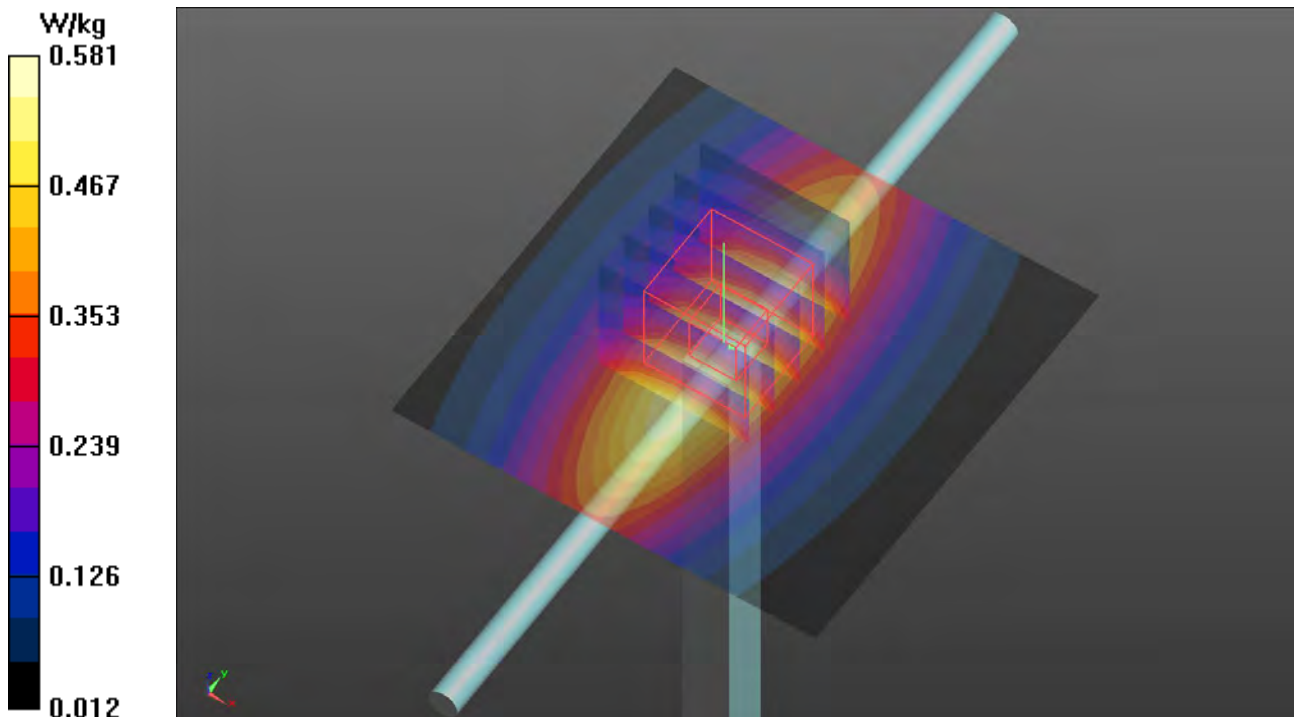

## Plots of System Verification

Test Laboratory: Bureau Veritas ADT SAR/HAC Testing Lab

Date: 2022/03/28

### S10 System Check\_H750\_220328

**DUT: Dipole 750 MHz; Type: D750V3; SN: 1013**

Communication System: UID 0, CW; Frequency: 750 MHz; Duty Cycle: 1:1

Medium: H06T09N1\_0328 Medium parameters used:  $f = 750$  MHz;  $\sigma = 0.902$  S/m;  $\epsilon_r = 41.582$ ;  $\rho = 1000$  kg/m<sup>3</sup>

Ambient Temperature : 23.8 °C ; Liquid Temperature : 23.4 °C

DASY5 Configuration:

- Probe: EX3DV4 - SN3578; ConvF(10.02, 10.02, 10.02) @ 750 MHz; Calibrated: 2021/06/23
- Sensor-Surface: 1.4mm (Mechanical Surface Detection)
- Electronics: DAE4 Sn915; Calibrated: 2021/06/02
- Phantom: ELI Phantom\_1043; Type: QD OVA 002 Ax
- Measurement SW: DASY52, Version 52.10 (4); SEMCAD X Version 14.6.14 (7501)

**Pin=50mW/Area Scan (61x61x1):** Interpolated grid: dx=1.500 mm, dy=1.500 mm

Maximum value of SAR (interpolated) = 0.581 W/kg

**Pin=50mW/Zoom Scan (5x5x7)/Cube 0:** Measurement grid: dx=8mm, dy=8mm, dz=5mm

Reference Value = 26.25 V/m; Power Drift = -0.01 dB

Peak SAR (extrapolated) = 0.657 W/kg

**SAR(1 g) = 0.438 W/kg; SAR(10 g) = 0.292 W/kg** (SAR corrected for target medium)

Maximum value of SAR (measured) = 0.586 W/kg

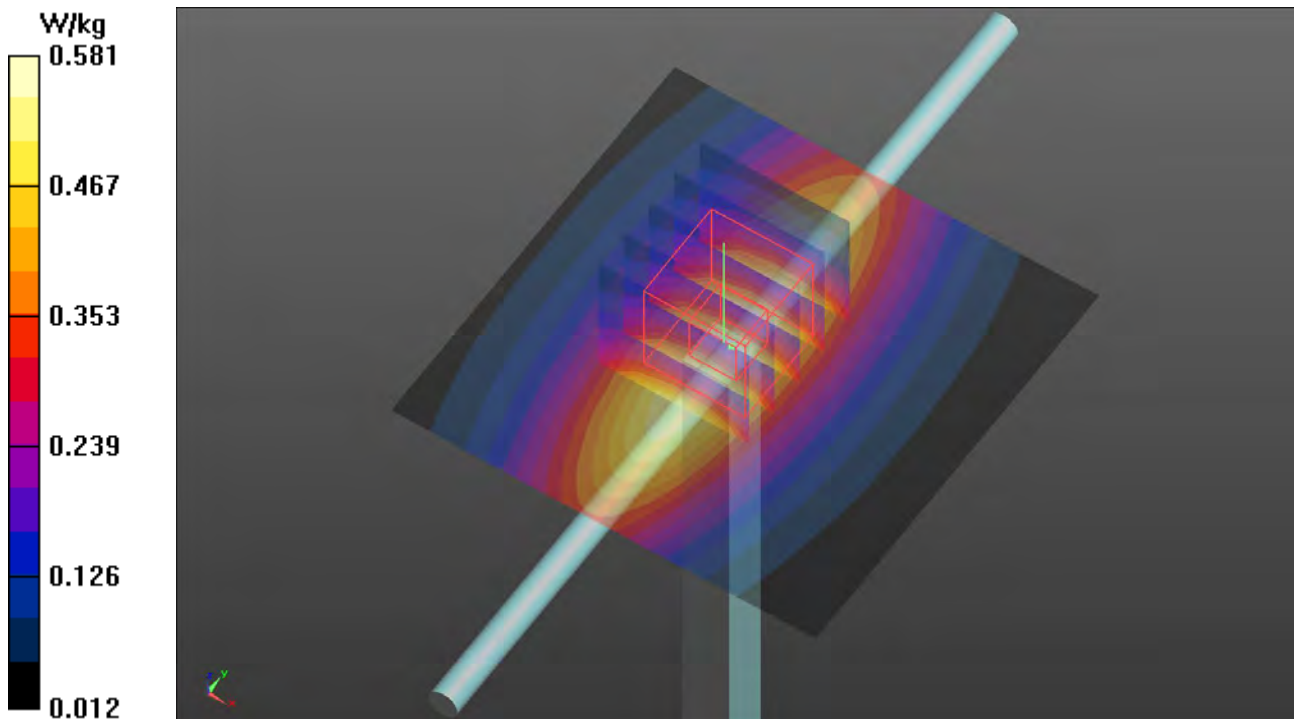

## Plots of System Verification

Test Laboratory: Bureau Veritas ADT SAR/HAC Testing Lab

Date: 2022/03/27

### S11 System Check\_H750\_220327

**DUT: Dipole 750 MHz; Type: D750V3; SN: 1013**

Communication System: UID 0, CW; Frequency: 750 MHz; Duty Cycle: 1:1

Medium: H06T09N1\_0327 Medium parameters used:  $f = 750$  MHz;  $\sigma = 0.915$  S/m;  $\epsilon_r = 40.84$ ;  $\rho = 1000$  kg/m<sup>3</sup>

Ambient Temperature : 23.7 °C ; Liquid Temperature : 23.5 °C

DASY5 Configuration:

- Probe: EX3DV4 - SN3578; ConvF(10.02, 10.02, 10.02) @ 750 MHz; Calibrated: 2021/06/23
- Sensor-Surface: 1.4mm (Mechanical Surface Detection)
- Electronics: DAE4 Sn915; Calibrated: 2021/06/02
- Phantom: ELI Phantom\_1043; Type: QD OVA 002 Ax
- Measurement SW: DASY52, Version 52.10 (4); SEMCAD X Version 14.6.14 (7501)

**Pin=50mW/Area Scan (61x61x1):** Interpolated grid:  $dx=1.500$  mm,  $dy=1.500$  mm  
Maximum value of SAR (interpolated) = 0.589 W/kg

**Pin=50mW/Zoom Scan (5x5x7)/Cube 0:** Measurement grid:  $dx=8$ mm,  $dy=8$ mm,  $dz=5$ mm  
Reference Value = 27.36 V/m; Power Drift = -0.04 dB

Peak SAR (extrapolated) = 0.666 W/kg

**SAR(1 g) = 0.440 W/kg; SAR(10 g) = 0.294 W/kg** (SAR corrected for target medium)

Maximum value of SAR (measured) = 0.594 W/kg

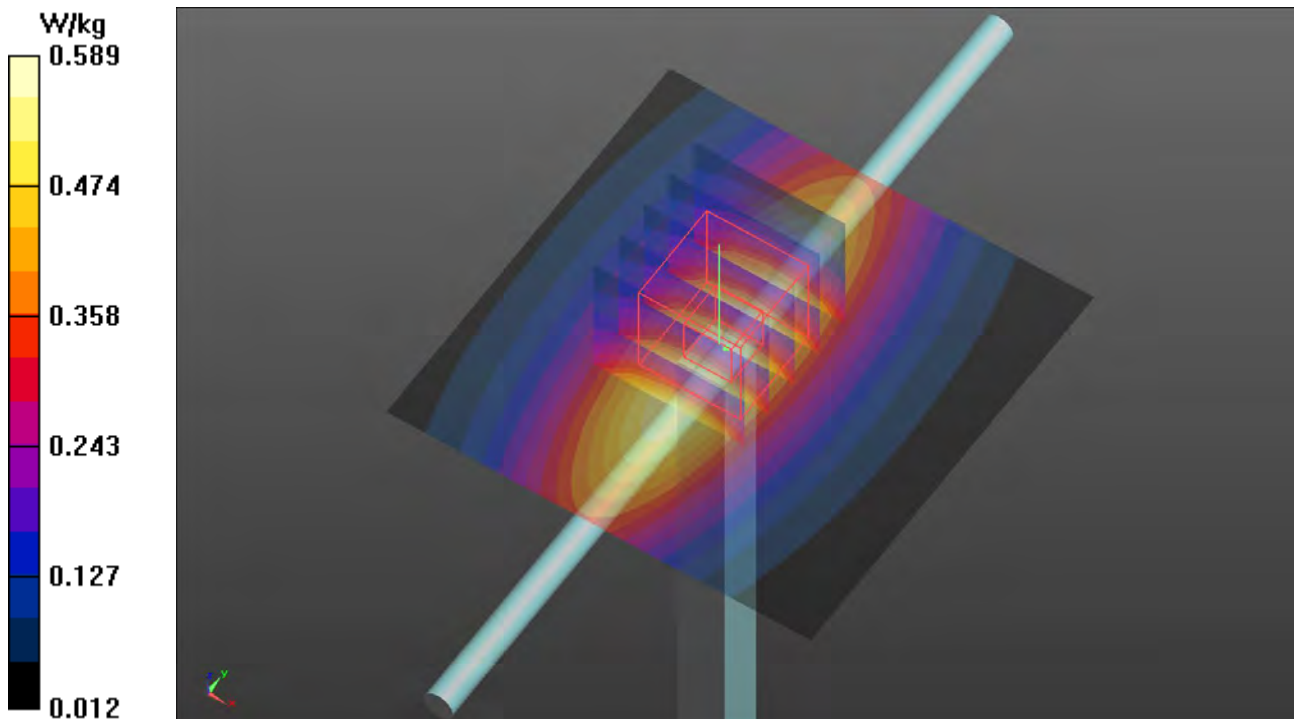

## Plots of System Verification

Test Laboratory: Bureau Veritas ADT SAR/HAC Testing Lab

Date: 2022/3/24

### S12 System Check\_H1900\_220324

DUT: Dipole 1900 MHz; Type: D1900V2; SN: 5d036

Communication System: UID 0, CW; Frequency: 1900 MHz; Duty Cycle: 1:1

Medium: H16T20N1\_0324 Medium parameters used:  $f = 1900$  MHz;  $\sigma = 1.463$  S/m;  $\epsilon_r = 38.787$ ;  $\rho = 1000$  kg/m<sup>3</sup>

Ambient Temperature : 23.7 °C ; Liquid Temperature : 23.3 °C

DASY5 Configuration:

- Probe: EX3DV4 - SN3578; ConvF(7.82, 7.82, 7.82) @ 1900 MHz; Calibrated: 2021/6/23
- Sensor-Surface: 1.4mm (Mechanical Surface Detection)
- Electronics: DAE4 Sn915; Calibrated: 2021/6/2
- Phantom: ELI Phantom\_1204; Type: QD OVA 002 Ax;
- Measurement SW: DASY52, Version 52.10 (4); SEMCAD X Version 14.6.14 (7501)

**Pin=50mW/Area Scan (61x61x1):** Interpolated grid: dx=1.500 mm, dy=1.500 mm

Maximum value of SAR (interpolated) = 3.290 W/kg

**Pin=50mW/Zoom Scan (5x5x7)/Cube 0:** Measurement grid: dx=8mm, dy=8mm, dz=5mm

Reference Value = 48.62 V/m; Power Drift = -0.02 dB

Peak SAR (extrapolated) = 4.01 W/kg

**SAR(1 g) = 2.02 W/kg; SAR(10 g) = 1.06 W/kg** (SAR corrected for target medium)

Maximum value of SAR (measured) = 3.31 W/kg

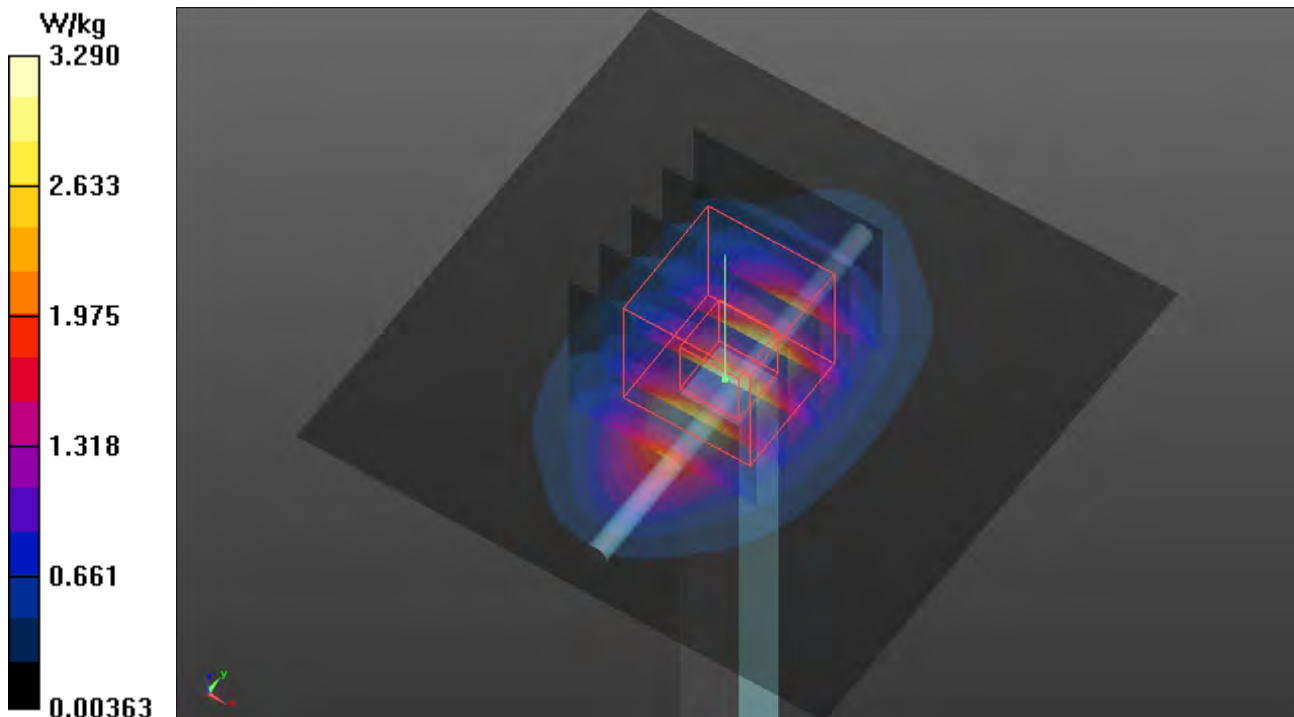

## Plots of System Verification

Test Laboratory: Bureau Veritas ADT SAR/HAC Testing Lab

Date: 2022/3/25

### S13 System Check\_H835\_220325

DUT: Dipole 835 MHz; Type: D835V2; SN: 4d121

Communication System: UID 0, CW; Frequency: 835 MHz; Duty Cycle: 1:1

Medium: H07T10N1\_0325 Medium parameters used:  $f = 835$  MHz;  $\sigma = 0.934$  S/m;  $\epsilon_r = 40.367$ ;  $\rho = 1000$  kg/m<sup>3</sup>

Ambient Temperature : 23.6 °C ; Liquid Temperature : 23.4 °C

DASY5 Configuration:

- Probe: EX3DV4 - SN3578; ConvF(9.54, 9.54, 9.54) @ 835 MHz; Calibrated: 2021/6/23
- Sensor-Surface: 1.4mm (Mechanical Surface Detection)
- Electronics: DAE4 Sn915; Calibrated: 2021/6/2
- Phantom: ELI Phantom\_1204; Type: QD OVA 002 Ax;
- Measurement SW: DASY52, Version 52.10 (4); SEMCAD X Version 14.6.14 (7501)

**Pin=50mW/Area Scan (61x61x1):** Interpolated grid: dx=1.500 mm, dy=1.500 mm

Maximum value of SAR (interpolated) = 0.636 W/kg

**Pin=50mW/Zoom Scan (5x5x7)/Cube 0:** Measurement grid: dx=8mm, dy=8mm, dz=5mm

Reference Value = 27.37 V/m; Power Drift = 0.02 dB

Peak SAR (extrapolated) = 0.714 W/kg

**SAR(1 g) = 0.461 W/kg; SAR(10 g) = 0.302 W/kg** (SAR corrected for target medium)

Maximum value of SAR (measured) = 0.634 W/kg

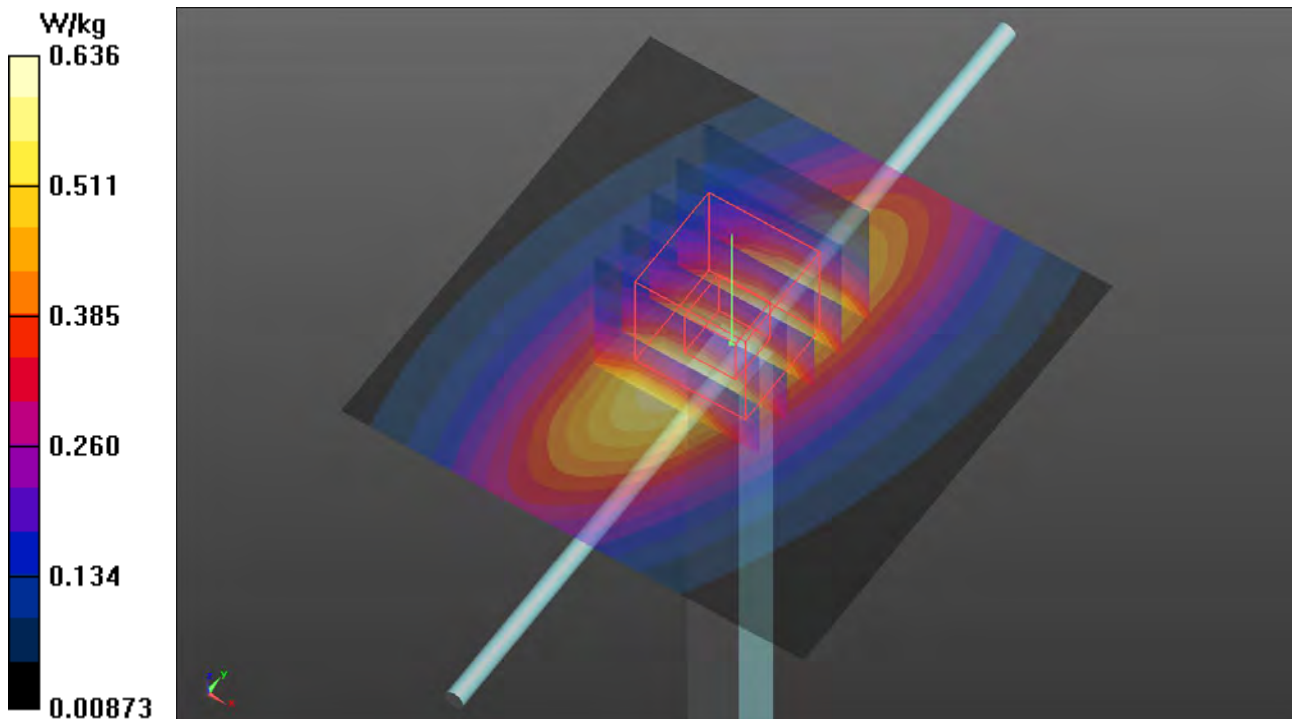

## Plots of System Verification

Test Laboratory: Bureau Veritas ADT SAR/HAC Testing Lab

Date: 2022/04/09

### S14 System Check\_H2300\_220409

**DUT: Dipole 2300 MHz; Type: D2300V2; SN: 1004**

Communication System: UID 0, CW; Frequency: 2300 MHz; Duty Cycle: 1:1

Medium: H19T27N1\_0409 Medium parameters used:  $f = 2300$  MHz;  $\sigma = 1.713$  S/m;  $\epsilon_r = 38.49$ ;  $\rho = 1000$  kg/m<sup>3</sup>

Ambient Temperature : 23.6 °C ; Liquid Temperature : 23.5 °C

DASY5 Configuration:

- Probe: EX3DV4 - SN3578; ConvF(7.58, 7.58, 7.58) @ 2300 MHz; Calibrated: 2021/06/23
- Sensor-Surface: 1.4mm (Mechanical Surface Detection)
- Electronics: DAE4 Sn915; Calibrated: 2021/06/02
- Phantom: ELI Phantom\_1043; Type: QD OVA 002 Ax;
- Measurement SW: DASY52, Version 52.10 (4); SEMCAD X Version 14.6.14 (7501)

**Pin=50mW/Area Scan (81x81x1):** Interpolated grid: dx=1.200 mm, dy=1.200 mm

Maximum value of SAR (interpolated) = 3.94 W/kg

**Pin=50mW/Zoom Scan (7x7x7)/Cube 0:** Measurement grid: dx=5mm, dy=5mm, dz=5mm

Reference Value = 49.69 V/m; Power Drift = 0.02 dB

Peak SAR (extrapolated) = 4.85 W/kg

**SAR(1 g) = 2.35 W/kg; SAR(10 g) = 1.13 W/kg** (SAR corrected for target medium)

Maximum value of SAR (measured) = 3.93 W/kg

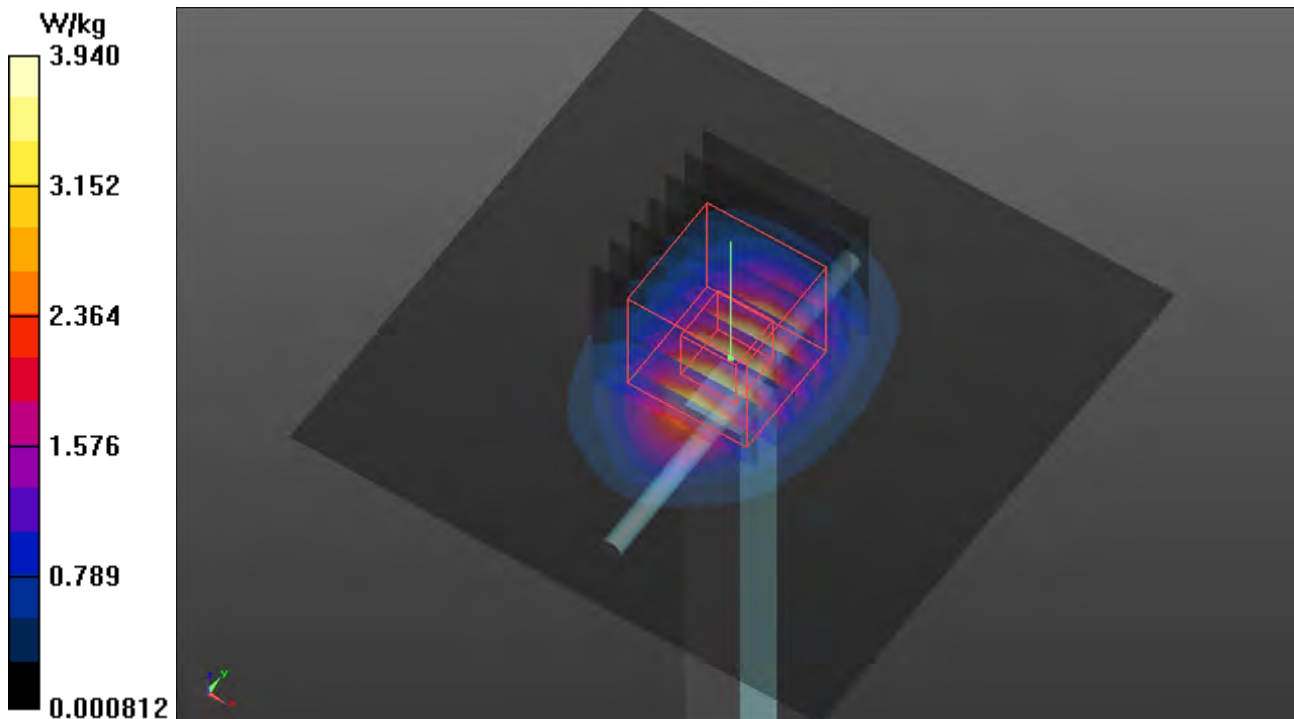

## Plots of System Verification

Test Laboratory: Bureau Veritas ADT SAR/HAC Testing Lab

Date: 2022/03/29

### S15 System Check\_H2600\_220329

**DUT: Dipole 2600 MHz; Type: D2600V2; SN: 1020**

Communication System: UID 0, CW; Frequency: 2600 MHz; Duty Cycle: 1:1

Medium: H19T27N3\_0329 Medium parameters used:  $f = 2600$  MHz;  $\sigma = 1.915$  S/m;  $\epsilon_r = 37.812$ ;  $\rho = 1000$  kg/m<sup>3</sup>

Ambient Temperature : 23.4 °C ; Liquid Temperature : 23.3 °C

DASY5 Configuration:

- Probe: EX3DV4 - SN3578; ConvF(7.22, 7.22, 7.22) @ 2600 MHz; Calibrated: 2021/06/23
- Sensor-Surface: 1.4mm (Mechanical Surface Detection)
- Electronics: DAE4 Sn915; Calibrated: 2021/06/02
- Phantom: ELI Phantom\_1043; Type: QD OVA 002 Ax
- Measurement SW: DASY52, Version 52.10 (4); SEMCAD X Version 14.6.14 (7501)

**Pin=50mW/Area Scan (81x81x1):** Interpolated grid: dx=1.200 mm, dy=1.200 mm

Maximum value of SAR (interpolated) = 4.69 W/kg

**Pin=50mW/Zoom Scan (7x7x7)/Cube 0:** Measurement grid: dx=5mm, dy=5mm, dz=5mm

Reference Value = 51.57 V/m; Power Drift = 0.05 dB

Peak SAR (extrapolated) = 5.84 W/kg

**SAR(1 g) = 2.75 W/kg; SAR(10 g) = 1.23 W/kg** (SAR corrected for target medium)

Maximum value of SAR (measured) = 4.68 W/kg

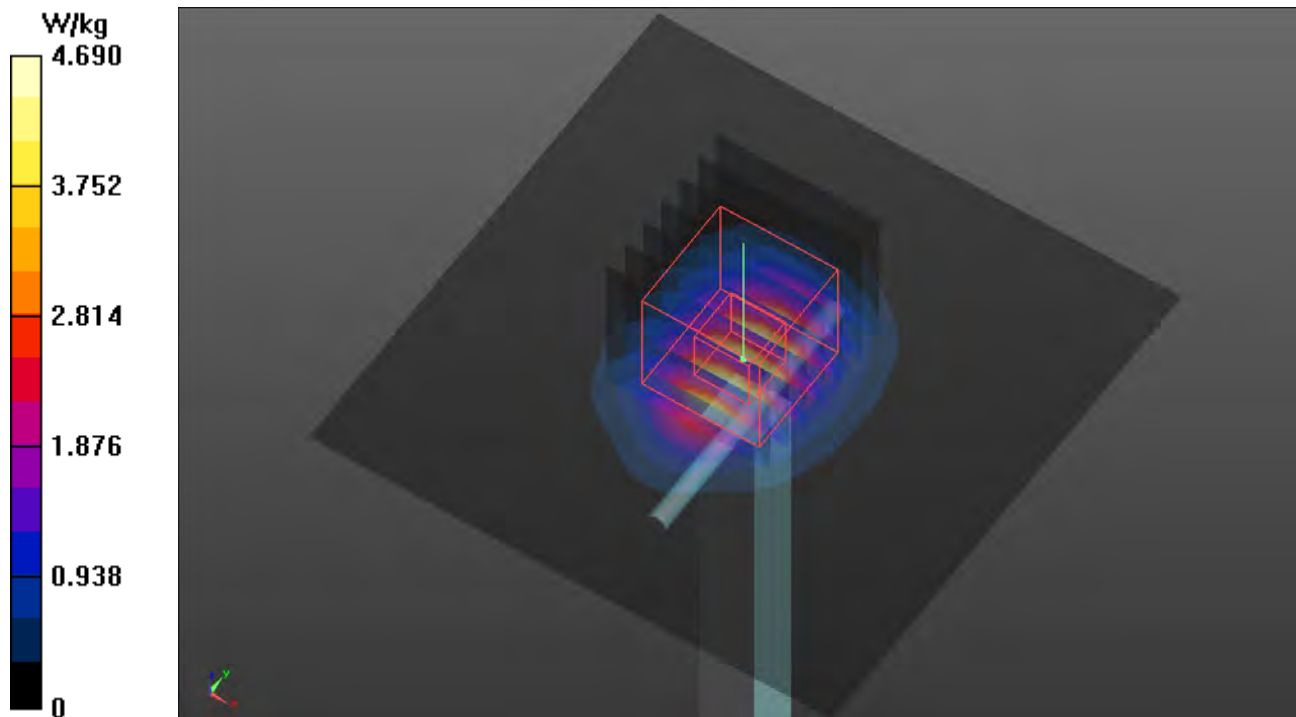



## Plots of System Verification

Test Laboratory: Bureau Veritas ADT SAR/HAC Testing Lab

Date: 2022/04/09

### S16 System Check\_H2300\_220409

**DUT: Dipole 2300 MHz; Type: D2300V2; SN:1004**

Communication System: UID 0, CW; Frequency: 2300 MHz; Duty Cycle: 1:1

Medium: H19T27N1\_0409 Medium parameters used:  $f = 2300$  MHz;  $\sigma = 1.713$  S/m;  $\epsilon_r = 38.49$ ;  $\rho = 1000$  kg/m<sup>3</sup>

Ambient Temperature : 23.6 °C ; Liquid Temperature : 23.5 °C

DASY5 Configuration:

- Probe: EX3DV4 - SN3578; ConvF(7.58, 7.58, 7.58) @ 2300 MHz; Calibrated: 2021/06/23
- Sensor-Surface: 1.4mm (Mechanical Surface Detection)
- Electronics: DAE4 Sn915; Calibrated: 2021/06/02
- Phantom: ELI Phantom\_1043; Type: QD OVA 002 Ax;
- Measurement SW: DASY52, Version 52.10 (4); SEMCAD X Version 14.6.14 (7501)

**Pin=50mW/Area Scan (81x81x1):** Interpolated grid: dx=1.200 mm, dy=1.200 mm

Maximum value of SAR (interpolated) = 3.94 W/kg

**Pin=50mW/Zoom Scan (7x7x7)/Cube 0:** Measurement grid: dx=5mm, dy=5mm, dz=5mm

Reference Value = 49.69 V/m; Power Drift = 0.02 dB

Peak SAR (extrapolated) = 4.85 W/kg

**SAR(1 g) = 2.35 W/kg; SAR(10 g) = 1.13 W/kg** (SAR corrected for target medium)

Maximum value of SAR (measured) = 3.93 W/kg

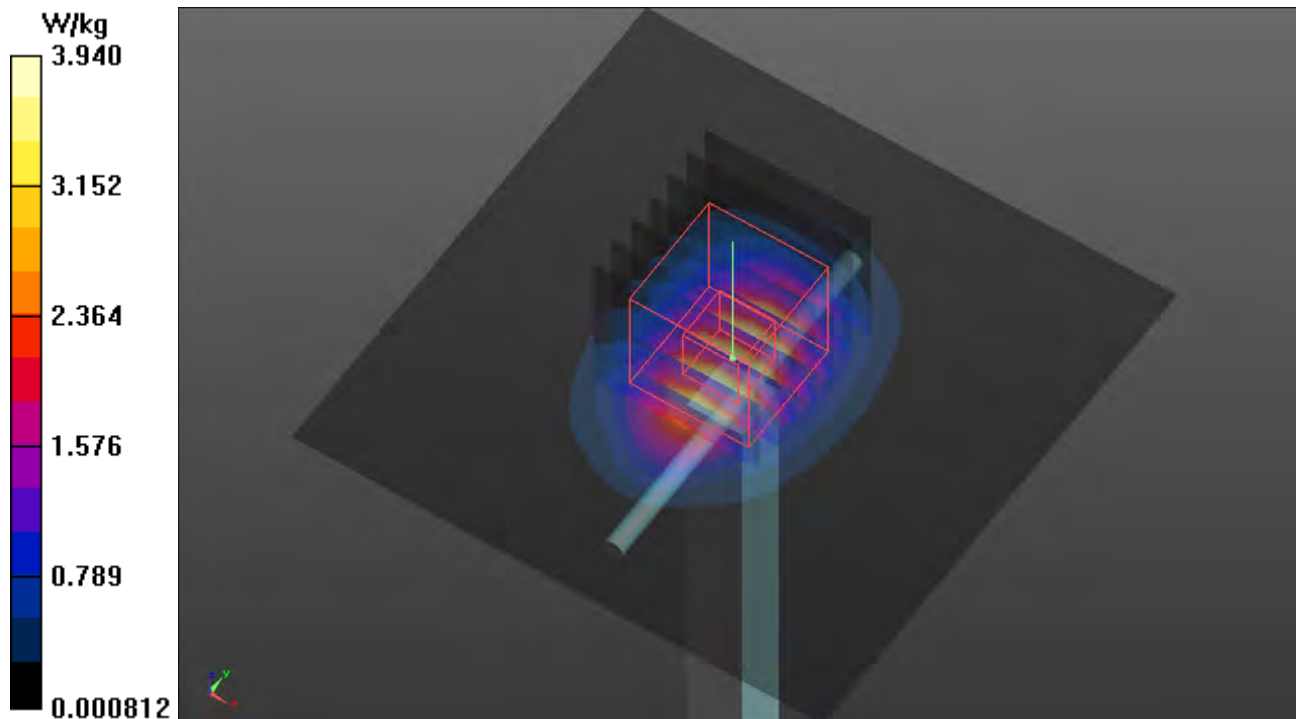

## Plots of System Verification

Test Laboratory: Bureau Veritas ADT SAR/HAC Testing Lab

Date: 2022/04/09

### S17 System Check\_H2600\_220409

**DUT: Dipole 2600 MHz; Type: D2600V2; SN: 1020**

Communication System: UID 0, CW; Frequency: 2600 MHz; Duty Cycle: 1:1

Medium: H19T27N1\_0409 Medium parameters used:  $f = 2600$  MHz;  $\sigma = 2.027$  S/m;  $\epsilon_r = 37.482$ ;  $\rho = 1000$  kg/m<sup>3</sup>

Ambient Temperature : 23.6 °C ; Liquid Temperature : 23.5 °C

DASY5 Configuration:

- Probe: EX3DV4 - SN3578; ConvF(7.22, 7.22, 7.22) @ 2600 MHz; Calibrated: 2021/06/23
- Sensor-Surface: 1.4mm (Mechanical Surface Detection)
- Electronics: DAE4 Sn915; Calibrated: 2021/06/02
- Phantom: ELI Phantom\_1043; Type: QD OVA 002 Ax;
- Measurement SW: DASY52, Version 52.10 (4); SEMCAD X Version 14.6.14 (7501)

**Pin=50mW/Area Scan (81x81x1):** Interpolated grid: dx=1.200 mm, dy=1.200 mm

Maximum value of SAR (interpolated) = 4.86 W/kg

**Pin=50mW/Zoom Scan (7x7x7)/Cube 0:** Measurement grid: dx=5mm, dy=5mm, dz=5mm

Reference Value = 50.61 V/m; Power Drift = 0.11 dB

Peak SAR (extrapolated) = 6.08 W/kg

**SAR(1 g) = 2.78 W/kg; SAR(10 g) = 1.26 W/kg** (SAR corrected for target medium)

Maximum value of SAR (measured) = 4.87 W/kg

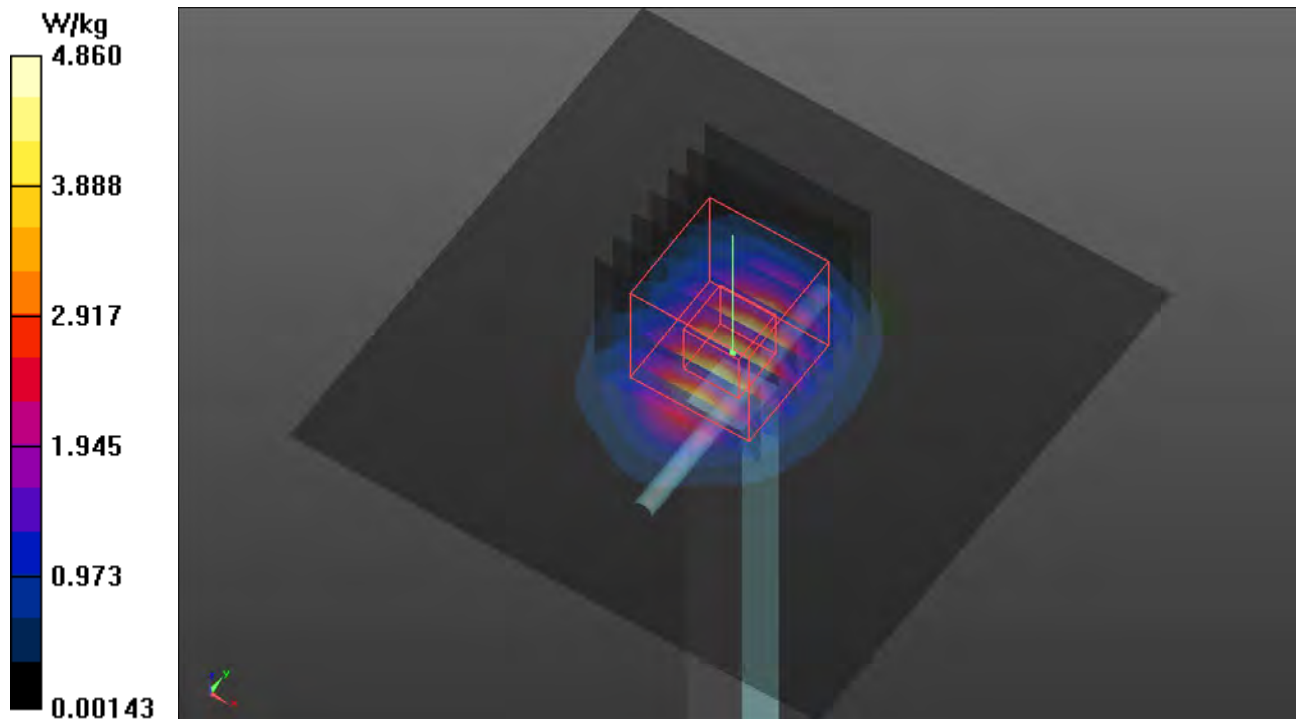

## Plots of System Verification

Test Laboratory: Bureau Veritas ADT SAR/HAC Testing Lab

Date: 2022/03/26

### S20a System Check\_H3500\_220326

**DUT: Dipole 3500 MHz; Type: D3500V2; SN: 1007**

Communication System: UID 0, CW; Frequency: 3500 MHz; Duty Cycle: 1:1

Medium: H33T42N1\_0326 Medium parameters used:  $f = 3500$  MHz;  $\sigma = 2.931$  S/m;  $\epsilon_r = 37.828$ ;  $\rho = 1000$  kg/m<sup>3</sup>

Ambient Temperature : 23.4 °C ; Liquid Temperature : 23.3 °C

DASY5 Configuration:

- Probe: EX3DV4 - SN3578; ConvF(7.06, 7.06, 7.06) @ 3500 MHz; Calibrated: 2021/06/23
- Sensor-Surface: 1.4mm (Mechanical Surface Detection)
- Electronics: DAE4 Sn915; Calibrated: 2021/06/02
- Phantom: ELI Phantom\_1043; Type: QD OVA 002 Ax
- Measurement SW: DASY52, Version 52.10 (4); SEMCAD X Version 14.6.14 (7501)

**Pin=50mW/Area Scan (81x81x1):** Interpolated grid: dx=1.200 mm, dy=1.200 mm

Maximum value of SAR (interpolated) = 6.33 W/kg

**Pin=50mW/Zoom Scan (7x7x6)/Cube 0:** Measurement grid: dx=5mm, dy=5mm, dz=2.5mm

Reference Value = 48.93 V/m; Power Drift = -0.17 dB

Peak SAR (extrapolated) = 8.61 W/kg

**SAR(1 g) = 3.33 W/kg; SAR(10 g) = 1.28 W/kg** (SAR corrected for target medium)

Maximum value of SAR (measured) = 6.40 W/kg

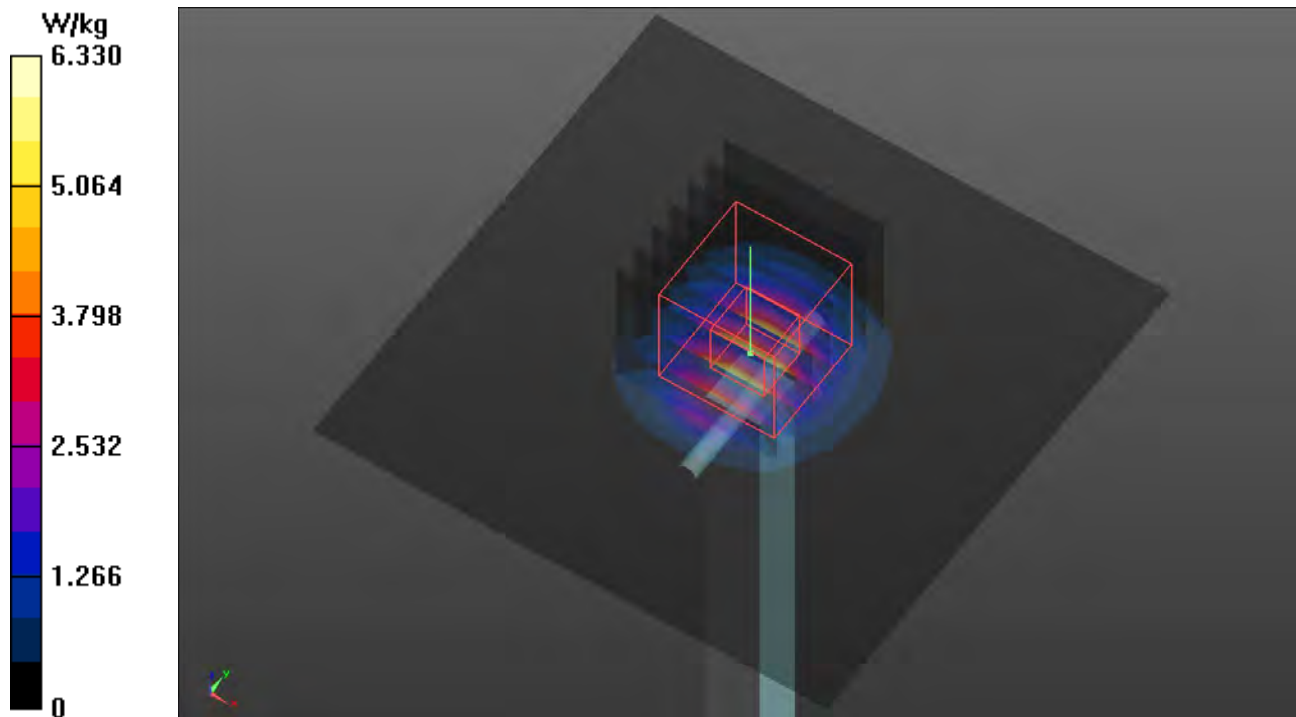

## Plots of System Verification

Test Laboratory: Bureau Veritas ADT SAR/HAC Testing Lab

Date: 2022/03/26

### S20b System Check\_H3700\_220326

**DUT: Dipole 3700 MHz; Type: D3700V2; SN: 1017**

Communication System: UID 0, CW; Frequency: 3700 MHz; Duty Cycle: 1:1

Medium: H33T42N1\_0326 Medium parameters used:  $f = 3700$  MHz;  $\sigma = 3.143$  S/m;  $\epsilon_r = 37.211$ ;  $\rho = 1000$  kg/m<sup>3</sup>

Ambient Temperature : 23.4 °C ; Liquid Temperature : 23.3 °C

DASY5 Configuration:

- Probe: EX3DV4 - SN3578; ConvF(6.96, 6.96, 6.96) @ 3700 MHz; Calibrated: 2021/06/23
- Sensor-Surface: 1.4mm (Mechanical Surface Detection)
- Electronics: DAE4 Sn915; Calibrated: 2021/06/02
- Phantom: ELI Phantom\_1043; Type: QD OVA 002 Ax;
- Measurement SW: DASY52, Version 52.10 (4); SEMCAD X Version 14.6.14 (7501)

**Pin=50mW/Area Scan (81x81x1):** Interpolated grid: dx=1.200 mm, dy=1.200 mm

Maximum value of SAR (interpolated) = 6.30 W/kg

**Pin=50mW/Zoom Scan (7x7x6)/Cube 0:** Measurement grid: dx=5mm, dy=5mm, dz=2.5mm

Reference Value = 46.27 V/m; Power Drift = 0.09 dB

Peak SAR (extrapolated) = 8.60 W/kg

**SAR(1 g) = 3.19 W/kg; SAR(10 g) = 1.2 W/kg** (SAR corrected for target medium)

Maximum value of SAR (measured) = 6.31 W/kg

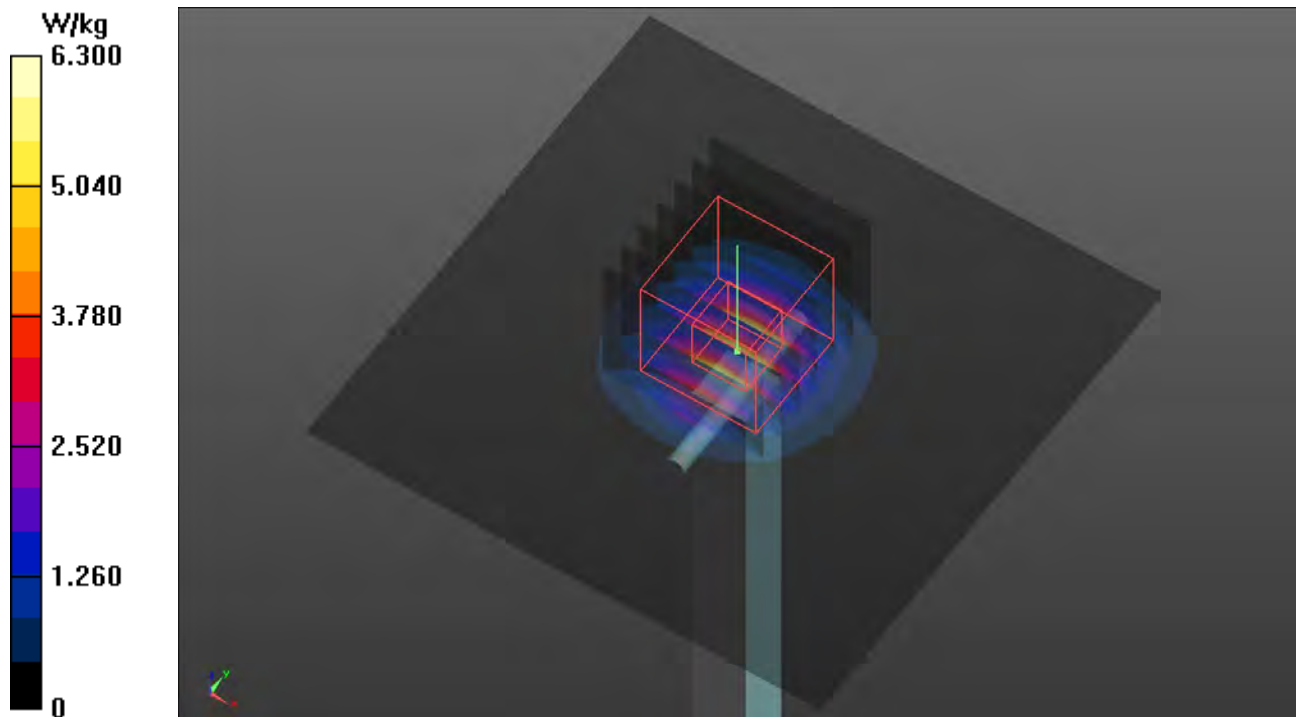

## Plots of System Verification

Test Laboratory: Bureau Veritas ADT SAR/HAC Testing Lab

Date: 2022/03/25

### S21 System Check\_H1750\_220325

DUT: Dipole 1750 MHz; Type: D1750V2; SN: 1055

Communication System: UID 0, CW; Frequency: 1750 MHz; Duty Cycle: 1:1

Medium: H16T20N1\_0325 Medium parameters used:  $f = 1750$  MHz;  $\sigma = 1.32$  S/m;  $\epsilon_r = 40.26$ ;  $\rho = 1000$  kg/m<sup>3</sup>

Ambient Temperature : 23.6 °C ; Liquid Temperature : 23.4 °C

DASY5 Configuration:

- Probe: EX3DV4 - SN3578; ConvF(8.09, 8.09, 8.09) @ 1750 MHz; Calibrated: 2021/6/23
- Sensor-Surface: 1.4mm (Mechanical Surface Detection)
- Electronics: DAE4 Sn915; Calibrated: 2021/6/2
- Phantom: ELI Phantom\_1204; Type: QD OVA 002 Ax;
- Measurement SW: DASY52, Version 52.10 (4); SEMCAD X Version 14.6.14 (7501)

**Pin=50mW/Area Scan (61x61x1):** Interpolated grid:  $dx=1.500$  mm,  $dy=1.500$  mm

Maximum value of SAR (interpolated) = 2.810 W/kg

**Pin=50mW/Zoom Scan (5x5x7)/Cube 0:** Measurement grid:  $dx=8$ mm,  $dy=8$ mm,  $dz=5$ mm

Reference Value = 47.07 V/m; Power Drift = -0.03 dB

Peak SAR (extrapolated) = 3.33 W/kg

**SAR(1 g) = 1.82 W/kg; SAR(10 g) = 0.954 W/kg** (SAR corrected for target medium)

Maximum value of SAR (measured) = 2.79 W/kg

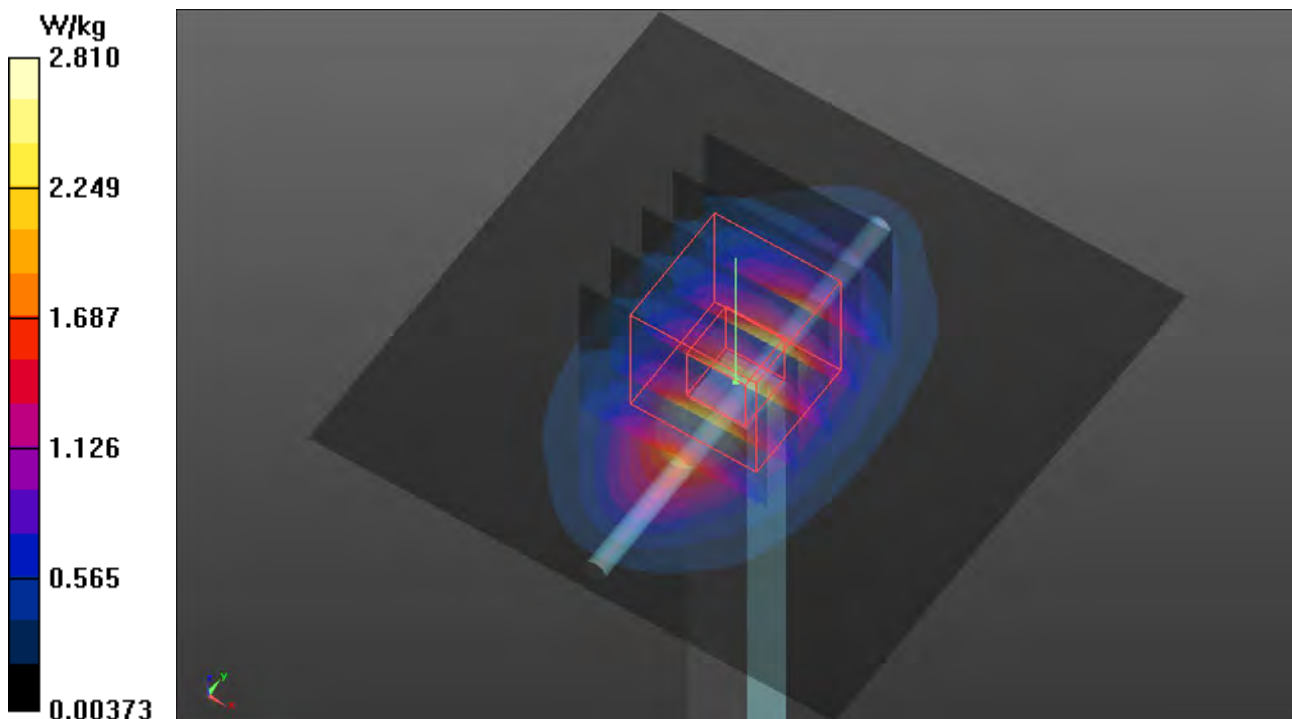

## Plots of System Verification

Test Laboratory: Bureau Veritas ADT SAR/HAC Testing Lab

Date: 2022/03/27

### S22 System Check\_H750\_220327

**DUT: Dipole 750 MHz; Type: D750V3; SN: 1013**

Communication System: UID 0, CW; Frequency: 750 MHz; Duty Cycle: 1:1

Medium: H06T09N1\_0327 Medium parameters used:  $f = 750$  MHz;  $\sigma = 0.915$  S/m;  $\epsilon_r = 40.84$ ;  $\rho = 1000$  kg/m<sup>3</sup>

Ambient Temperature : 23.7 °C ; Liquid Temperature : 23.5 °C

DASY5 Configuration:

- Probe: EX3DV4 - SN3578; ConvF(10.02, 10.02, 10.02) @ 750 MHz; Calibrated: 2021/06/23
- Sensor-Surface: 1.4mm (Mechanical Surface Detection)
- Electronics: DAE4 Sn915; Calibrated: 2021/06/02
- Phantom: ELI Phantom\_1043; Type: QD OVA 002 Ax
- Measurement SW: DASY52, Version 52.10 (4); SEMCAD X Version 14.6.14 (7501)

**Pin=50mW/Area Scan (61x61x1):** Interpolated grid: dx=1.500 mm, dy=1.500 mm

Maximum value of SAR (interpolated) = 0.589 W/kg

**Pin=50mW/Zoom Scan (5x5x7)/Cube 0:** Measurement grid: dx=8mm, dy=8mm, dz=5mm

Reference Value = 27.36 V/m; Power Drift = -0.04 dB

Peak SAR (extrapolated) = 0.666 W/kg

**SAR(1 g) = 0.440 W/kg; SAR(10 g) = 0.294 W/kg** (SAR corrected for target medium)

Maximum value of SAR (measured) = 0.594 W/kg

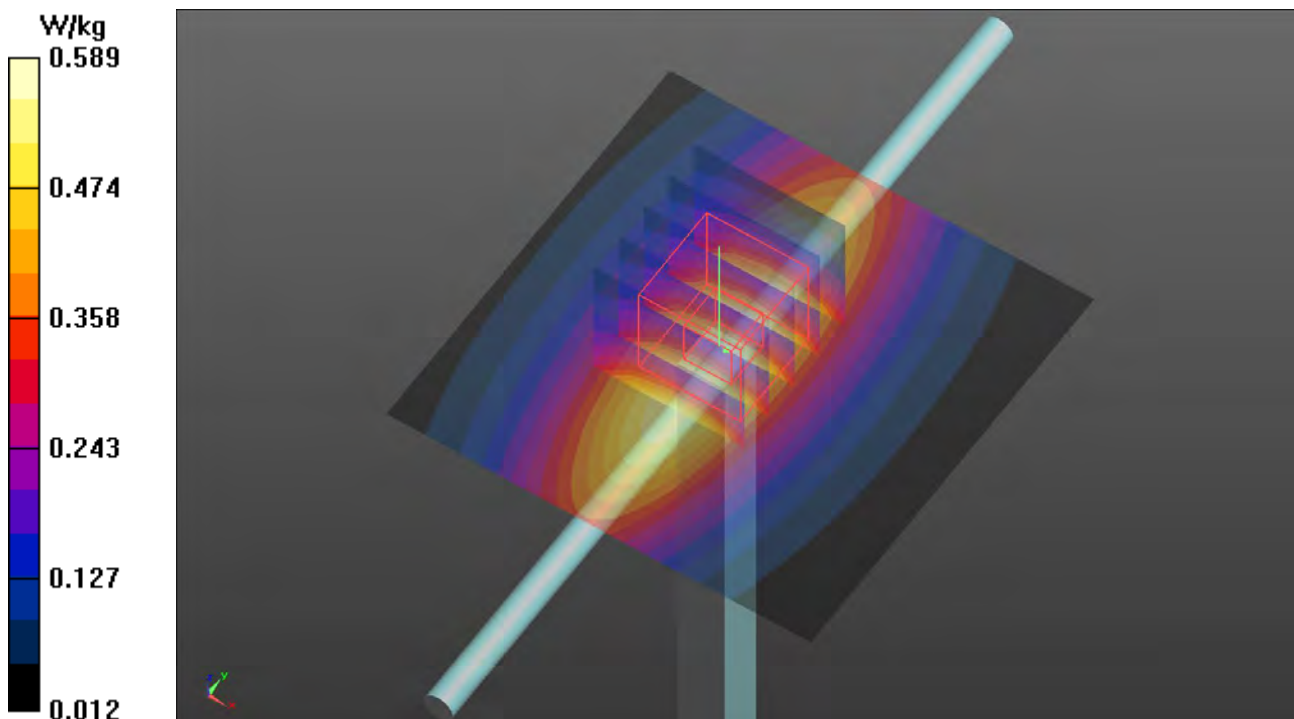

## Plots of System Verification

Test Laboratory: Bureau Veritas ADT SAR/HAC Testing Lab

Date: 2022/3/24

### S23 System Check\_H1900\_220324

DUT: Dipole 1900 MHz; Type: D1900V2; SN: 5d036

Communication System: UID 0, CW; Frequency: 1900 MHz; Duty Cycle: 1:1

Medium: H16T20N1\_0324 Medium parameters used:  $f = 1900$  MHz;  $\sigma = 1.463$  S/m;  $\epsilon_r = 38.787$ ;  $\rho = 1000$  kg/m<sup>3</sup>

Ambient Temperature : 23.7 °C ; Liquid Temperature : 23.3 °C

DASY5 Configuration:

- Probe: EX3DV4 - SN3578; ConvF(7.82, 7.82, 7.82) @ 1900 MHz; Calibrated: 2021/6/23
- Sensor-Surface: 1.4mm (Mechanical Surface Detection)
- Electronics: DAE4 Sn915; Calibrated: 2021/6/2
- Phantom: ELI Phantom\_1204; Type: QD OVA 002 Ax;
- Measurement SW: DASY52, Version 52.10 (4); SEMCAD X Version 14.6.14 (7501)

**Pin=50mW/Area Scan (61x61x1):** Interpolated grid: dx=1.500 mm, dy=1.500 mm

Maximum value of SAR (interpolated) = 3.290 W/kg

**Pin=50mW/Zoom Scan (5x5x7)/Cube 0:** Measurement grid: dx=8mm, dy=8mm, dz=5mm

Reference Value = 48.62 V/m; Power Drift = -0.02 dB

Peak SAR (extrapolated) = 4.01 W/kg

**SAR(1 g) = 2.02 W/kg; SAR(10 g) = 1.06 W/kg** (SAR corrected for target medium)

Maximum value of SAR (measured) = 3.31 W/kg

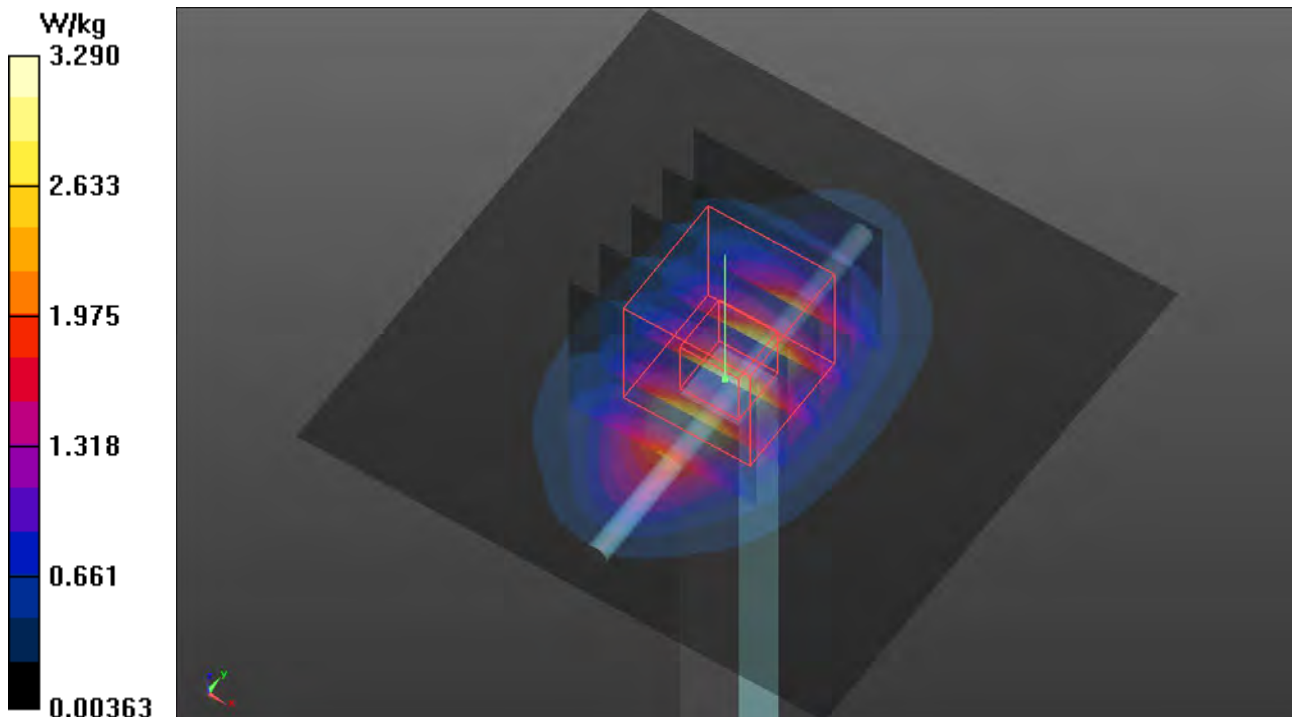

## Plots of System Verification

Test Laboratory: Bureau Veritas ADT SAR/HAC Testing Lab

Date: 2022/3/25

### S24 System Check\_H835\_220325

DUT: Dipole 835 MHz; Type: D835V2; SN: 4d121

Communication System: UID 0, CW; Frequency: 835 MHz; Duty Cycle: 1:1

Medium: H07T10N1\_0325 Medium parameters used:  $f = 835$  MHz;  $\sigma = 0.934$  S/m;  $\epsilon_r = 40.367$ ;  $\rho = 1000$  kg/m<sup>3</sup>

Ambient Temperature : 23.6 °C ; Liquid Temperature : 23.4 °C

DASY5 Configuration:

- Probe: EX3DV4 - SN3578; ConvF(9.54, 9.54, 9.54) @ 835 MHz; Calibrated: 2021/6/23
- Sensor-Surface: 1.4mm (Mechanical Surface Detection)
- Electronics: DAE4 Sn915; Calibrated: 2021/6/2
- Phantom: ELI Phantom\_1204; Type: QD OVA 002 Ax;
- Measurement SW: DASY52, Version 52.10 (4); SEMCAD X Version 14.6.14 (7501)

**Pin=50mW/Area Scan (61x61x1):** Interpolated grid: dx=1.500 mm, dy=1.500 mm

Maximum value of SAR (interpolated) = 0.636 W/kg

**Pin=50mW/Zoom Scan (5x5x7)/Cube 0:** Measurement grid: dx=8mm, dy=8mm, dz=5mm

Reference Value = 27.37 V/m; Power Drift = 0.02 dB

Peak SAR (extrapolated) = 0.714 W/kg

**SAR(1 g) = 0.461 W/kg; SAR(10 g) = 0.302 W/kg** (SAR corrected for target medium)

Maximum value of SAR (measured) = 0.634 W/kg

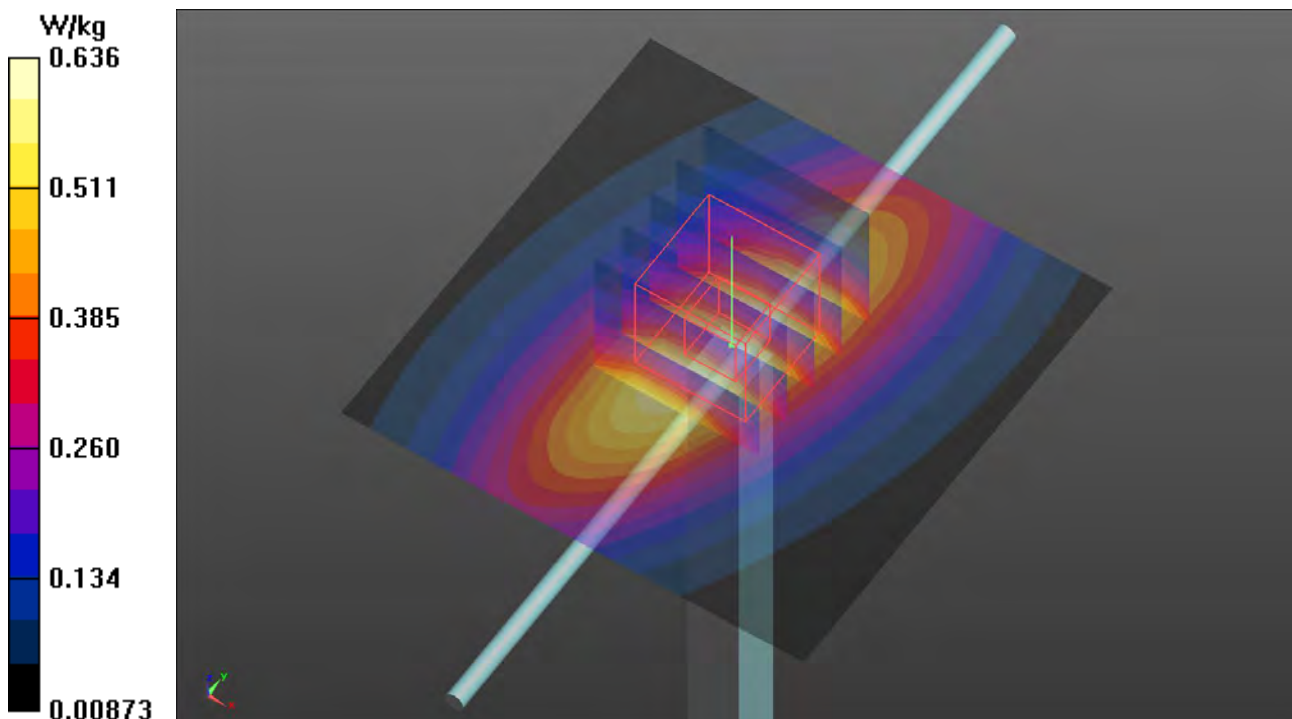



## Plots of System Verification

Test Laboratory: Bureau Veritas ADT SAR/HAC Testing Lab

Date: 2022/03/29

### S25 System Check\_H2600\_220329

**DUT: Dipole 2600 MHz; Type: D2600V2; SN: 1020**

Communication System: UID 0, CW; Frequency: 2600 MHz; Duty Cycle: 1:1

Medium: H19T27N3\_0329 Medium parameters used:  $f = 2600$  MHz;  $\sigma = 1.915$  S/m;  $\epsilon_r = 37.812$ ;  $\rho = 1000$  kg/m<sup>3</sup>

Ambient Temperature : 23.4 °C ; Liquid Temperature : 23.3 °C

DASY5 Configuration:

- Probe: EX3DV4 - SN3578; ConvF(7.22, 7.22, 7.22) @ 2600 MHz; Calibrated: 2021/06/23
- Sensor-Surface: 1.4mm (Mechanical Surface Detection)
- Electronics: DAE4 Sn915; Calibrated: 2021/06/02
- Phantom: ELI Phantom\_1043; Type: QD OVA 002 Ax
- Measurement SW: DASY52, Version 52.10 (4); SEMCAD X Version 14.6.14 (7501)

**Pin=50mW/Area Scan (81x81x1):** Interpolated grid:  $dx=1.200$  mm,  $dy=1.200$  mm

Maximum value of SAR (interpolated) = 4.69 W/kg

**Pin=50mW/Zoom Scan (7x7x7)/Cube 0:** Measurement grid:  $dx=5$ mm,  $dy=5$ mm,  $dz=5$ mm

Reference Value = 51.57 V/m; Power Drift = 0.05 dB

Peak SAR (extrapolated) = 5.84 W/kg

**SAR(1 g) = 2.75 W/kg; SAR(10 g) = 1.23 W/kg** (SAR corrected for target medium)

Maximum value of SAR (measured) = 4.68 W/kg

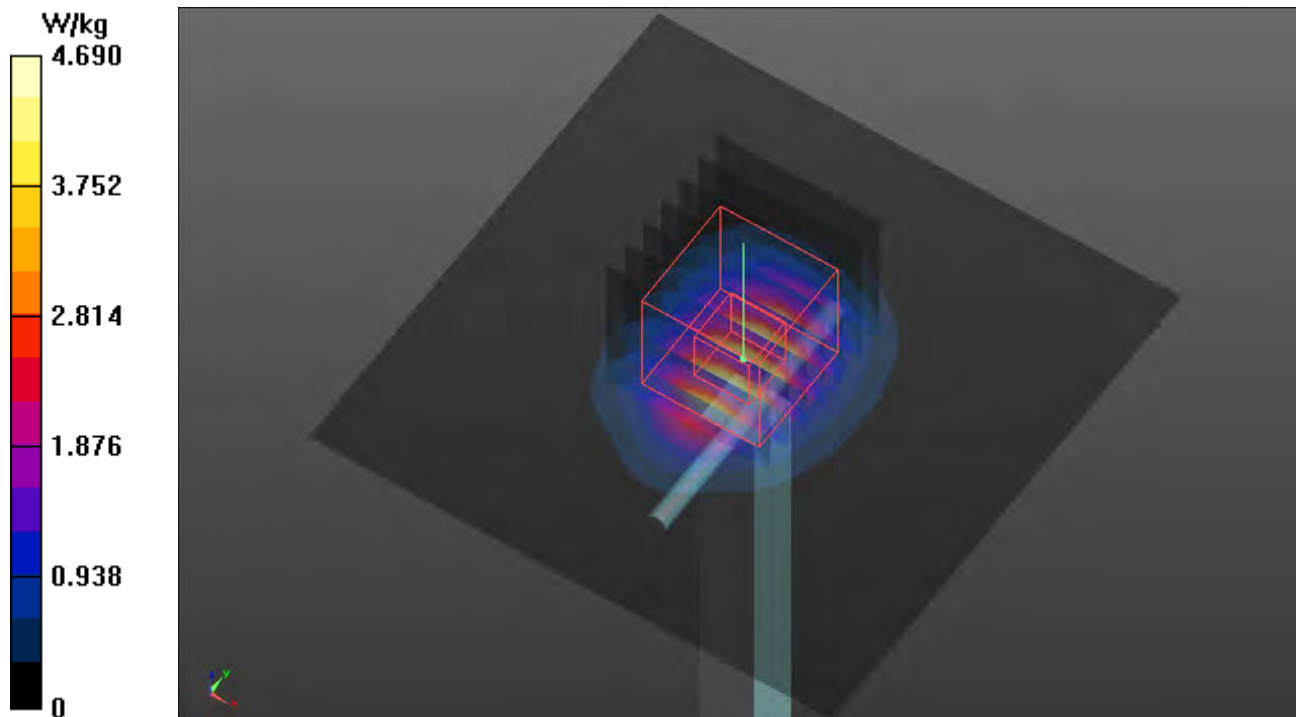

## Plots of System Verification

Test Laboratory: Bureau Veritas ADT SAR/HAC Testing Lab

Date: 2022/3/25

### S26 System Check\_H1900\_220325

DUT: Dipole 1900 MHz; Type: D1900V2; SN: 5d036

Communication System: UID 0, CW; Frequency: 1900 MHz; Duty Cycle: 1:1

Medium: H16T20N1\_0325 Medium parameters used:  $f = 1900$  MHz;  $\sigma = 1.456$  S/m;  $\epsilon_r = 39.705$ ;  $\rho = 1000$  kg/m<sup>3</sup>

Ambient Temperature : 23.6 °C ; Liquid Temperature : 23.4 °C

DASY5 Configuration:

- Probe: EX3DV4 - SN3578; ConvF(7.82, 7.82, 7.82) @ 1900 MHz; Calibrated: 2021/6/23
- Sensor-Surface: 1.4mm (Mechanical Surface Detection)
- Electronics: DAE4 Sn915; Calibrated: 2021/6/2
- Phantom: ELI Phantom\_1204; Type: QD OVA 002 Ax;
- Measurement SW: DASY52, Version 52.10 (4); SEMCAD X Version 14.6.14 (7501)

**Pin=50mW/Area Scan (61x61x1):** Interpolated grid: dx=1.500 mm, dy=1.500 mm

Maximum value of SAR (interpolated) = 3.270 W/kg

**Pin=50mW/Zoom Scan (5x5x7)/Cube 0:** Measurement grid: dx=8mm, dy=8mm, dz=5mm

Reference Value = 48.62 V/m; Power Drift = -0.02 dB

Peak SAR (extrapolated) = 3.99 W/kg

**SAR(1 g) = 2.02 W/kg; SAR(10 g) = 1.06 W/kg** (SAR corrected for target medium)

Maximum value of SAR (measured) = 3.30 W/kg

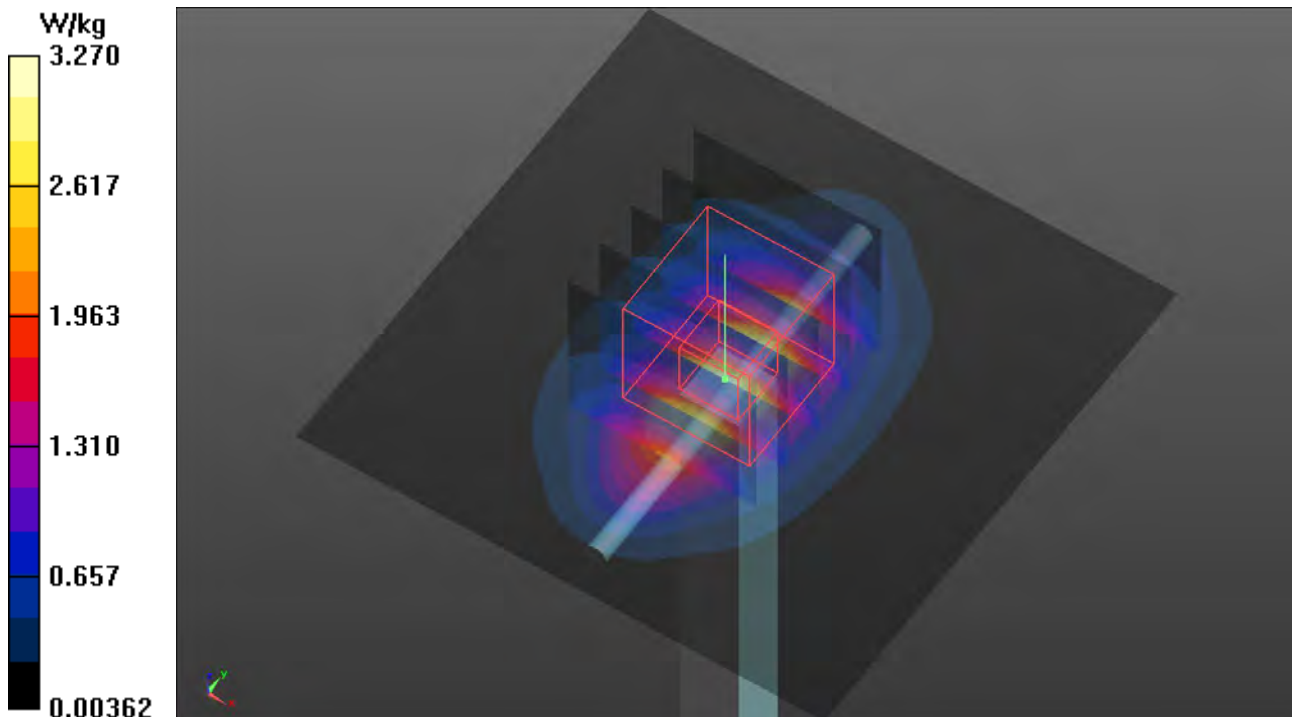

## Plots of System Verification

Test Laboratory: Bureau Veritas ADT SAR/HAC Testing Lab

Date: 2022/03/29

### S27 System Check\_H2300\_220329

**DUT: Dipole 2300 MHz; Type: D2300V2; SN: 1004**

Communication System: UID 0, CW; Frequency: 2300 MHz; Duty Cycle: 1:1

Medium: H19T27N3\_0329 Medium parameters used:  $f = 2300$  MHz;  $\sigma = 1.689$  S/m;  $\epsilon_r = 38.323$ ;  $\rho = 1000$  kg/m<sup>3</sup>

Ambient Temperature : 23.4 °C ; Liquid Temperature : 23.3 °C

DASY5 Configuration:

- Probe: EX3DV4 - SN3578; ConvF(7.58, 7.58, 7.58) @ 2300 MHz; Calibrated: 2021/06/23
- Sensor-Surface: 1.4mm (Mechanical Surface Detection)
- Electronics: DAE4 Sn915; Calibrated: 2021/06/02
- Phantom: ELI Phantom\_1043; Type: QD OVA 002 Ax;
- Measurement SW: DASY52, Version 52.10 (4); SEMCAD X Version 14.6.14 (7501)

**Pin=50mW/Area Scan (81x81x1):** Interpolated grid: dx=1.200 mm, dy=1.200 mm

Maximum value of SAR (interpolated) = 3.93 W/kg

**Pin=50mW/Zoom Scan (7x7x7)/Cube 0:** Measurement grid: dx=5mm, dy=5mm, dz=5mm

Reference Value = 48.82 V/m; Power Drift = -0.02 dB

Peak SAR (extrapolated) = 4.83 W/kg

**SAR(1 g) = 2.34 W/kg; SAR(10 g) = 1.13 W/kg** (SAR corrected for target medium)

Maximum value of SAR (measured) = 3.92 W/kg

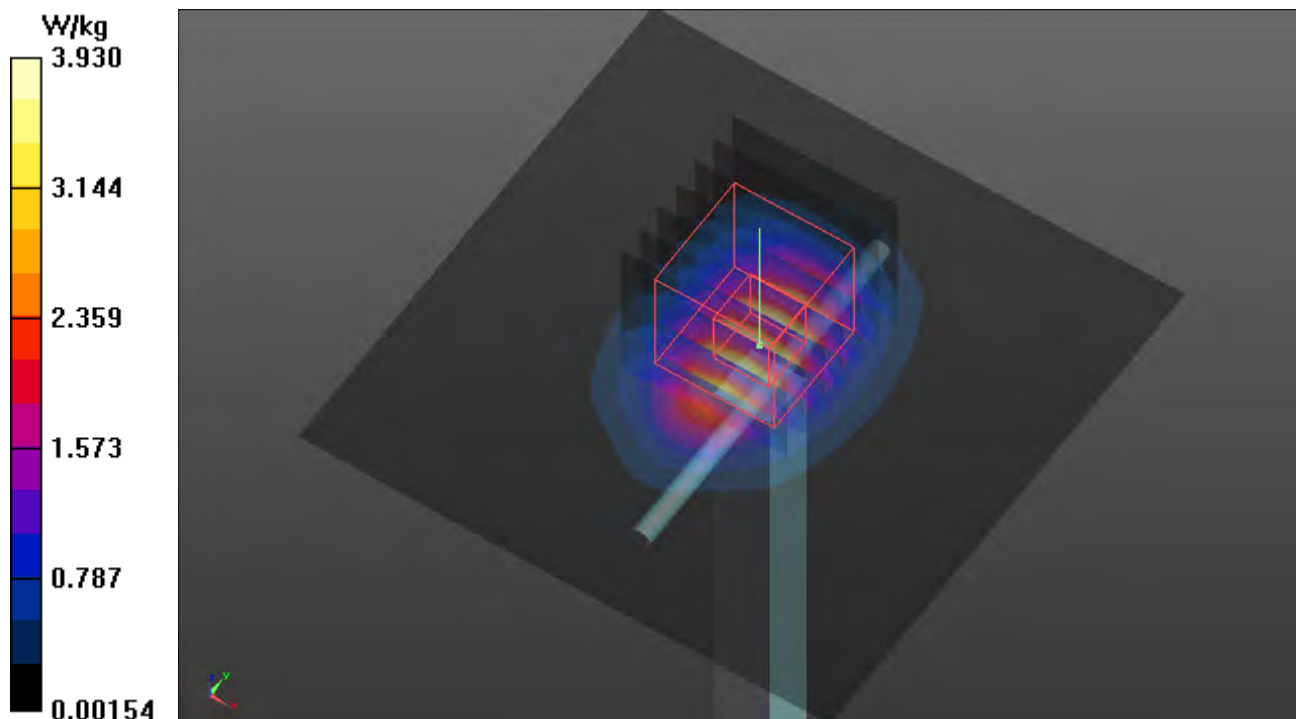

## Plots of System Verification

Test Laboratory: Bureau Veritas ADT SAR/HAC Testing Lab

Date: 2022/03/29

### S28 System Check\_H2600\_220329

**DUT: Dipole 2600 MHz; Type: D2600V2; SN: 1020**

Communication System: UID 0, CW; Frequency: 2600 MHz; Duty Cycle: 1:1

Medium: H19T27N3\_0329 Medium parameters used:  $f = 2600$  MHz;  $\sigma = 1.915$  S/m;  $\epsilon_r = 37.812$ ;  $\rho = 1000$  kg/m<sup>3</sup>

Ambient Temperature : 23.4 °C ; Liquid Temperature : 23.3 °C

DASY5 Configuration:

- Probe: EX3DV4 - SN3578; ConvF(7.22, 7.22, 7.22) @ 2600 MHz; Calibrated: 2021/06/23
- Sensor-Surface: 1.4mm (Mechanical Surface Detection)
- Electronics: DAE4 Sn915; Calibrated: 2021/06/02
- Phantom: ELI Phantom\_1043; Type: QD OVA 002 Ax
- Measurement SW: DASY52, Version 52.10 (4); SEMCAD X Version 14.6.14 (7501)

**Pin=50mW/Area Scan (81x81x1):** Interpolated grid: dx=1.200 mm, dy=1.200 mm

Maximum value of SAR (interpolated) = 4.69 W/kg

**Pin=50mW/Zoom Scan (7x7x7)/Cube 0:** Measurement grid: dx=5mm, dy=5mm, dz=5mm

Reference Value = 51.57 V/m; Power Drift = 0.05 dB

Peak SAR (extrapolated) = 5.84 W/kg

**SAR(1 g) = 2.75 W/kg; SAR(10 g) = 1.23 W/kg** (SAR corrected for target medium)

Maximum value of SAR (measured) = 4.68 W/kg

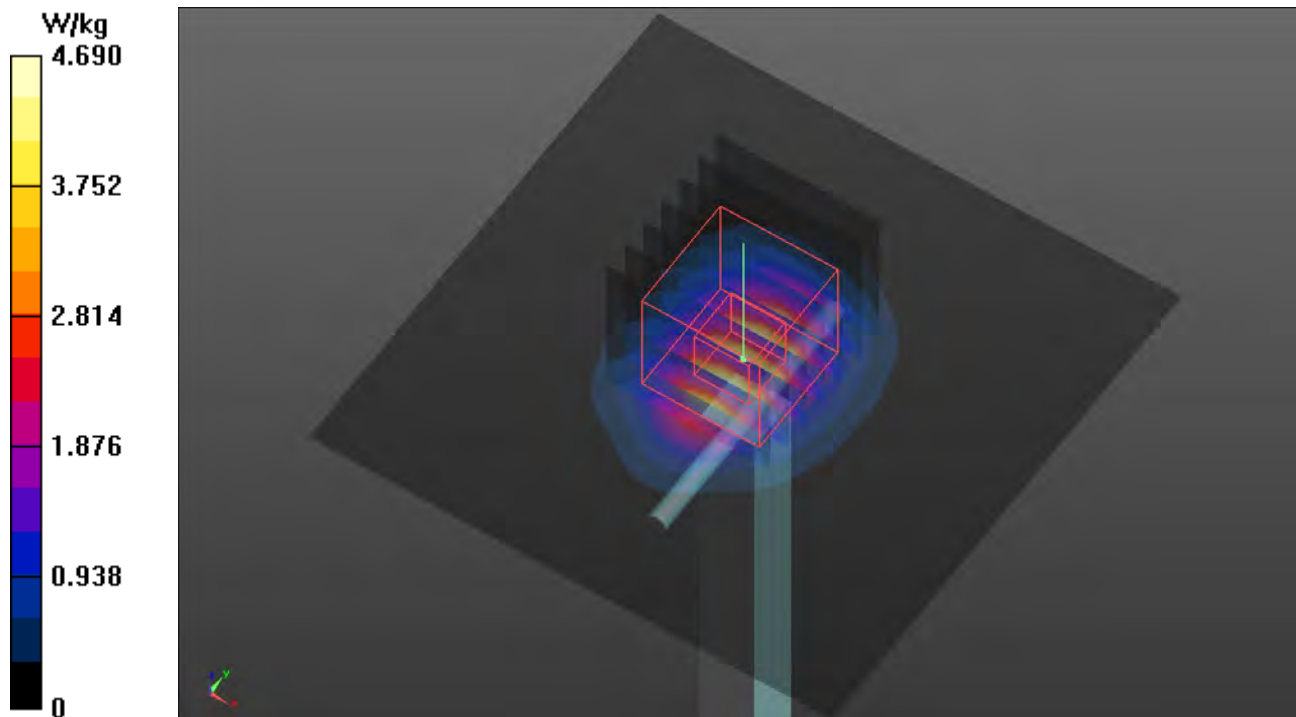

## Plots of System Verification

Test Laboratory: Bureau Veritas ADT SAR/HAC Testing Lab

Date: 2022/03/30

### S29 System Check\_H2300\_220330

**DUT: Dipole 2300 MHz; Type: D2300V2; SN: 1004**

Communication System: UID 0, CW; Frequency: 2300 MHz; Duty Cycle: 1:1

Medium: H19T27N1\_0330 Medium parameters used:  $f = 2300$  MHz;  $\sigma = 1.714$  S/m;  $\epsilon_r = 39.059$ ;  $\rho = 1000$  kg/m<sup>3</sup>

Ambient Temperature : 23.3 °C ; Liquid Temperature : 23.1 °C

DASY5 Configuration:

- Probe: EX3DV4 - SN3578; ConvF(7.58, 7.58, 7.58) @ 2300 MHz; Calibrated: 2021/06/23
- Sensor-Surface: 1.4mm (Mechanical Surface Detection)
- Electronics: DAE4 Sn915; Calibrated: 2021/06/02
- Phantom: ELI Phantom\_1043; Type: QD OVA 002 Ax;
- Measurement SW: DASY52, Version 52.10 (4); SEMCAD X Version 14.6.14 (7501)

**Pin=50mW/Area Scan (81x81x1):** Interpolated grid:  $dx=1.200$  mm,  $dy=1.200$  mm

Maximum value of SAR (interpolated) = 3.99 W/kg

**Pin=50mW/Zoom Scan (7x7x7)/Cube 0:** Measurement grid:  $dx=5$ mm,  $dy=5$ mm,  $dz=5$ mm

Reference Value = 48.82 V/m; Power Drift = -0.02 dB

Peak SAR (extrapolated) = 4.91 W/kg

**SAR(1 g) = 2.37 W/kg; SAR(10 g) = 1.14 W/kg** (SAR corrected for target medium)

Maximum value of SAR (measured) = 3.98 W/kg

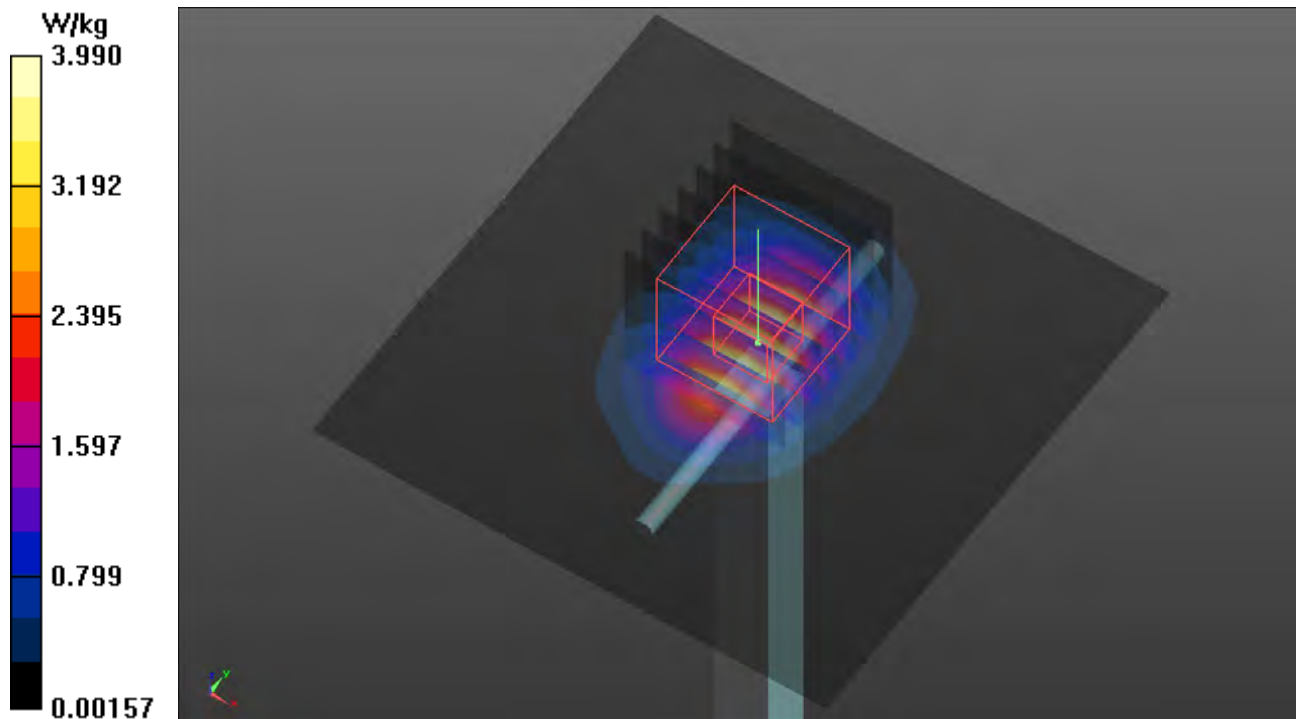

## Plots of System Verification

Test Laboratory: Bureau Veritas ADT SAR/HAC Testing Lab

Date: 2022/04/03

### S30 System Check\_H2600\_220403

**DUT: Dipole 2600 MHz; Type: D2600V2; SN: 1020**

Communication System: UID 0, CW; Frequency: 2600 MHz; Duty Cycle: 1:1

Medium: H19T27N1\_0403 Medium parameters used:  $f = 2600$  MHz;  $\sigma = 1.975$  S/m;  $\epsilon_r = 38.417$ ;  $\rho = 1000$  kg/m<sup>3</sup>

Ambient Temperature : 23.8 °C ; Liquid Temperature : 23.6 °C

DASY5 Configuration:

- Probe: EX3DV4 - SN3578; ConvF(7.22, 7.22, 7.22) @ 2600 MHz; Calibrated: 2021/06/23
- Sensor-Surface: 1.4mm (Mechanical Surface Detection)
- Electronics: DAE4 Sn915; Calibrated: 2021/06/02
- Phantom: ELI Phantom\_1043; Type: QD OVA 002 Ax
- Measurement SW: DASY52, Version 52.10 (4); SEMCAD X Version 14.6.14 (7501)

**Pin=50mW/Area Scan (81x81x1):** Interpolated grid: dx=1.200 mm, dy=1.200 mm

Maximum value of SAR (interpolated) = 4.83 W/kg

**Pin=50mW/Zoom Scan (7x7x7)/Cube 0:** Measurement grid: dx=5mm, dy=5mm, dz=5mm

Reference Value = 51.57 V/m; Power Drift = 0.05 dB

Peak SAR (extrapolated) = 6.02 W/kg

**SAR(1 g) = 2.81 W/kg; SAR(10 g) = 1.27 W/kg** (SAR corrected for target medium)

Maximum value of SAR (measured) = 4.83 W/kg

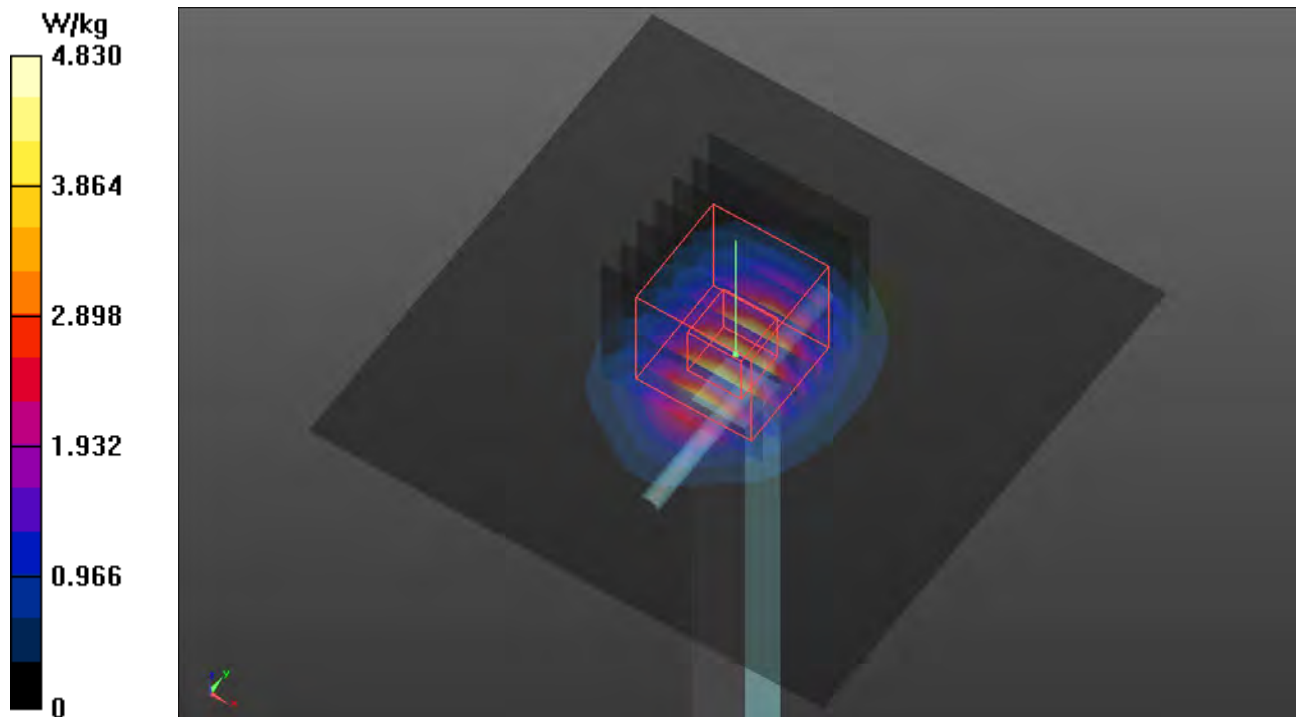

## Plots of System Verification

Test Laboratory: Bureau Veritas ADT SAR/HAC Testing Lab

Date: 2022/03/25

### S32 System Check\_H1750\_220325

DUT: Dipole 1750 MHz; Type: D1750V2; SN: 1055

Communication System: UID 0, CW; Frequency: 1750 MHz; Duty Cycle: 1:1

Medium: H16T20N1\_0325 Medium parameters used:  $f = 1750$  MHz;  $\sigma = 1.32$  S/m;  $\epsilon_r = 40.26$ ;  $\rho = 1000$  kg/m<sup>3</sup>

Ambient Temperature : 23.6 °C ; Liquid Temperature : 23.4 °C

DASY5 Configuration:

- Probe: EX3DV4 - SN3578; ConvF(8.09, 8.09, 8.09) @ 1750 MHz; Calibrated: 2021/6/23
- Sensor-Surface: 1.4mm (Mechanical Surface Detection)
- Electronics: DAE4 Sn915; Calibrated: 2021/6/2
- Phantom: ELI Phantom\_1204; Type: QD OVA 002 Ax;
- Measurement SW: DASY52, Version 52.10 (4); SEMCAD X Version 14.6.14 (7501)

**Pin=50mW/Area Scan (61x61x1):** Interpolated grid: dx=1.500 mm, dy=1.500 mm

Maximum value of SAR (interpolated) = 2.81 W/kg

**Pin=50mW/Zoom Scan (5x5x7)/Cube 0:** Measurement grid: dx=8mm, dy=8mm, dz=5mm

Reference Value = 47.07 V/m; Power Drift = -0.03 dB

Peak SAR (extrapolated) = 3.33 W/kg

**SAR(1 g) = 1.82 W/kg; SAR(10 g) = 0.954 W/kg** (SAR corrected for target medium)

Maximum value of SAR (measured) = 2.79 W/kg

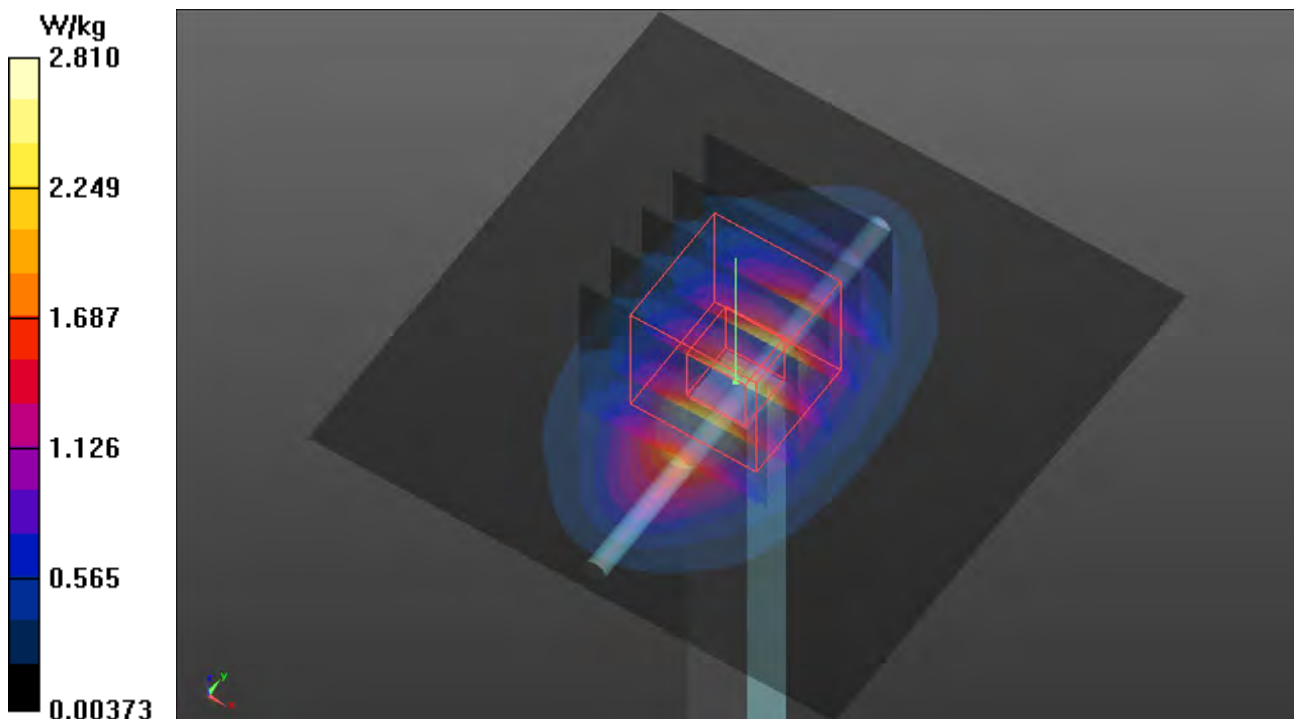

## Plots of System Verification

Test Laboratory: Bureau Veritas ADT SAR/HAC Testing Lab

Date: 2022/03/27

### S33 System Check\_H750\_220327

**DUT: Dipole 750 MHz; Type: D750V3; SN: 1013**

Communication System: UID 0, CW; Frequency: 750 MHz; Duty Cycle: 1:1

Medium: H06T09N1\_0327 Medium parameters used:  $f = 750$  MHz;  $\sigma = 0.915$  S/m;  $\epsilon_r = 40.84$ ;  $\rho = 1000$  kg/m<sup>3</sup>

Ambient Temperature : 23.7 °C ; Liquid Temperature : 23.5 °C

DASY5 Configuration:

- Probe: EX3DV4 - SN3578; ConvF(10.02, 10.02, 10.02) @ 750 MHz; Calibrated: 2021/06/23
- Sensor-Surface: 1.4mm (Mechanical Surface Detection)
- Electronics: DAE4 Sn915; Calibrated: 2021/06/02
- Phantom: ELI Phantom\_1043; Type: QD OVA 002 Ax
- Measurement SW: DASY52, Version 52.10 (4); SEMCAD X Version 14.6.14 (7501)

**Pin=50mW/Area Scan (61x61x1):** Interpolated grid: dx=1.500 mm, dy=1.500 mm  
Maximum value of SAR (interpolated) = 0.589 W/kg

**Pin=50mW/Zoom Scan (5x5x7)/Cube 0:** Measurement grid: dx=8mm, dy=8mm, dz=5mm  
Reference Value = 27.36 V/m; Power Drift = -0.04 dB

Peak SAR (extrapolated) = 0.666 W/kg

**SAR(1 g) = 0.440 W/kg; SAR(10 g) = 0.294 W/kg** (SAR corrected for target medium)

Maximum value of SAR (measured) = 0.594 W/kg

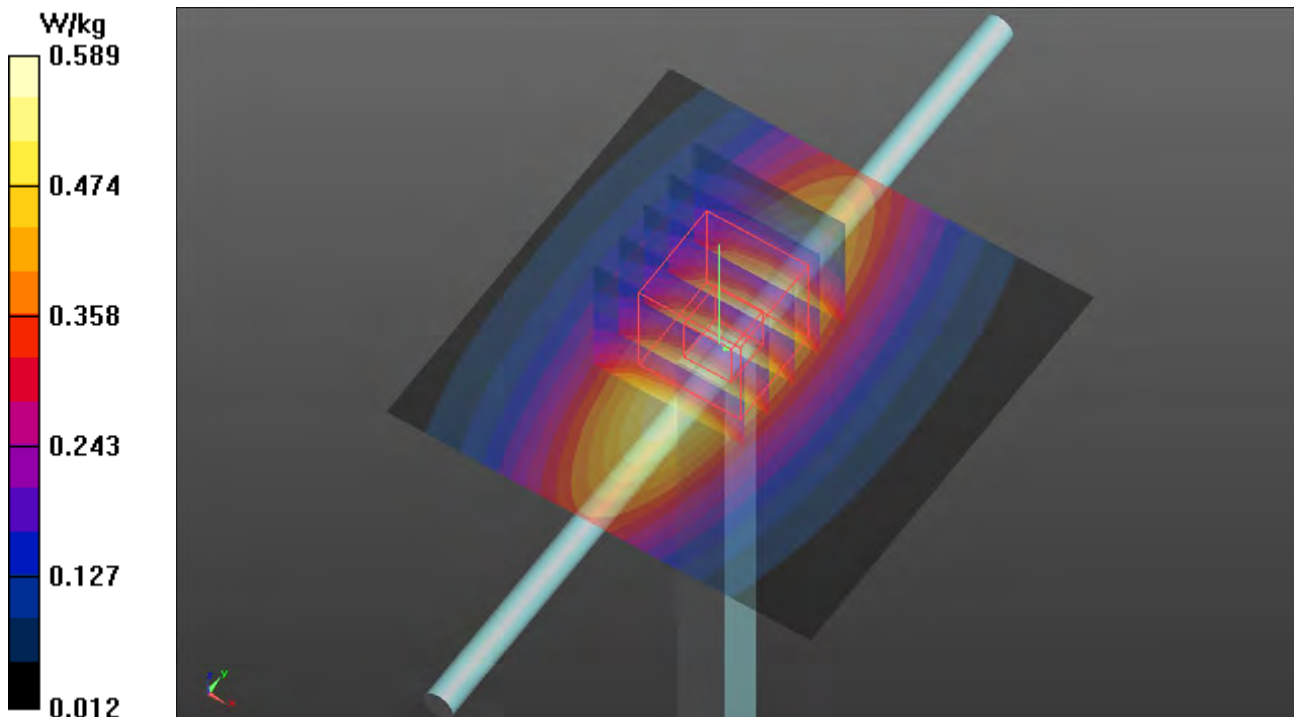



## Plots of System Verification

Test Laboratory: Bureau Veritas ADT SAR/HAC Testing Lab

Date: 2022/04/03

### S34a System Check\_H3700\_220403

**DUT: Dipole 3700 MHz; Type: D3700V2; SN: 1017**

Communication System: UID 0, CW; Frequency: 3700 MHz; Duty Cycle: 1:1

Medium: H33T42N2\_0403 Medium parameters used:  $f = 3700$  MHz;  $\sigma = 3.027$  S/m;  $\epsilon_r = 38.261$ ;  $\rho = 1000$  kg/m<sup>3</sup>

Ambient Temperature : 23.8 °C ; Liquid Temperature : 23.6 °C

DASY5 Configuration:

- Probe: EX3DV4 - SN3578; ConvF(6.96, 6.96, 6.96) @ 3700 MHz; Calibrated: 2021/06/23
- Sensor-Surface: 1.4mm (Mechanical Surface Detection)
- Electronics: DAE4 Sn915; Calibrated: 2021/06/02
- Phantom: ELI Phantom\_1043; Type: QD OVA 002 Ax
- Measurement SW: DASY52, Version 52.10 (4); SEMCAD X Version 14.6.14 (7501)

**Pin=50mW/Area Scan (81x81x1):** Interpolated grid: dx=1.200 mm, dy=1.200 mm

Maximum value of SAR (interpolated) = 6.07 W/kg

**Pin=50mW/Zoom Scan (7x7x6)/Cube 0:** Measurement grid: dx=5mm, dy=5mm, dz=2.5mm

Reference Value = 46.27 V/m; Power Drift = 0.09 dB

Peak SAR (extrapolated) = 8.29 W/kg

**SAR(1 g) = 3.11 W/kg; SAR(10 g) = 1.17 W/kg** (SAR corrected for target medium)

Maximum value of SAR (measured) = 6.07 W/kg

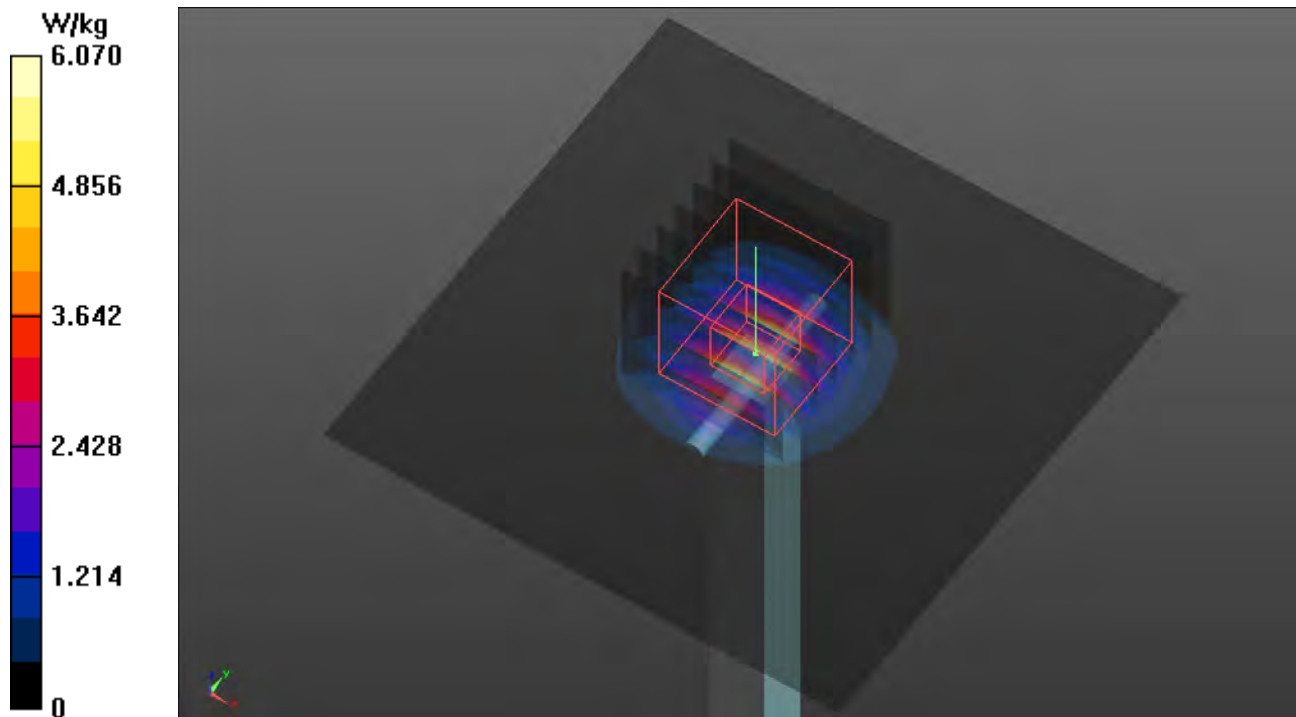

## Plots of System Verification

Test Laboratory: Bureau Veritas ADT SAR/HAC Testing Lab

Date: 2022/04/03

### S34b System Check\_H3900\_220403

**DUT: Dipole 3900 MHz; Type: D3900V2; SN: 1020**

Communication System: UID 0, CW; Frequency: 3900 MHz; Duty Cycle: 1:1

Medium: H33T42N2\_0403 Medium parameters used:  $f = 3900$  MHz;  $\sigma = 3.235$  S/m;  $\epsilon_r = 37.92$ ;  $\rho = 1000$  kg/m<sup>3</sup>

Ambient Temperature : 23.8 °C ; Liquid Temperature : 23.6 °C

DASY5 Configuration:

- Probe: EX3DV4 - SN3578; ConvF(6.81, 6.81, 6.81) @ 3900 MHz; Calibrated: 2021/06/23
- Sensor-Surface: 1.4mm (Mechanical Surface Detection)
- Electronics: DAE4 Sn915; Calibrated: 2021/06/02
- Phantom: ELI Phantom\_1043; Type: QD OVA 002 Ax
- Measurement SW: DASY52, Version 52.10 (4); SEMCAD X Version 14.6.14 (7501)

**Pin=50mW/Area Scan (81x81x1):** Interpolated grid: dx=1.200 mm, dy=1.200 mm

Maximum value of SAR (interpolated) = 6.54 W/kg

**Pin=50mW/Zoom Scan (7x7x7)/Cube 0:** Measurement grid: dx=5mm, dy=5mm, dz=2.5mm

Reference Value = 47.51 V/m; Power Drift = 0.02 dB

Peak SAR (extrapolated) = 9.29 W/kg

**SAR(1 g) = 3.25 W/kg; SAR(10 g) = 1.16 W/kg** (SAR corrected for target medium)

Maximum value of SAR (measured) = 6.58 W/kg

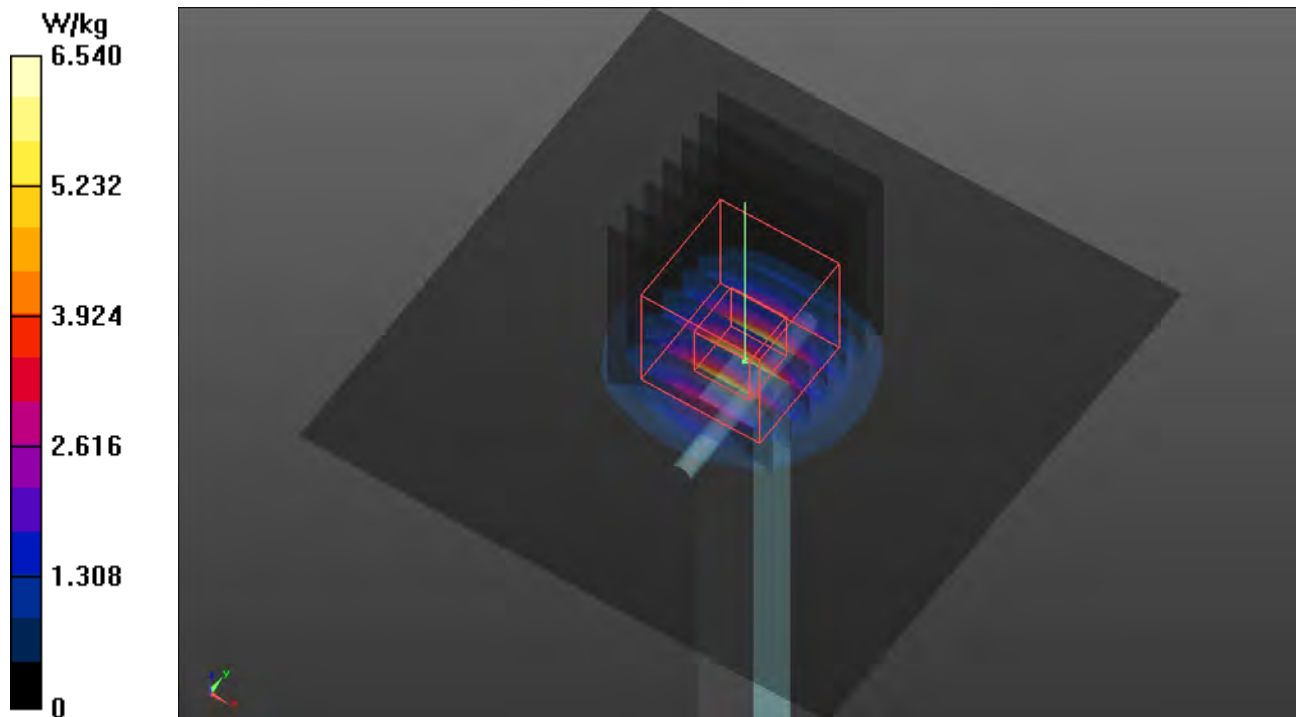

## Plots of System Verification

Test Laboratory: Bureau Veritas ADT SAR/HAC Testing Lab

Date: 2022/04/03

### S35 System Check\_H3700\_220403

**DUT: Dipole 3700 MHz; Type: D3700V2; SN: 1017**

Communication System: UID 0, CW; Frequency: 3700 MHz; Duty Cycle: 1:1

Medium: H33T42N2\_0403 Medium parameters used:  $f = 3700$  MHz;  $\sigma = 3.027$  S/m;  $\epsilon_r = 38.261$ ;  $\rho = 1000$  kg/m<sup>3</sup>

Ambient Temperature : 23.8 °C ; Liquid Temperature : 23.6 °C

DASY5 Configuration:

- Probe: EX3DV4 - SN3578; ConvF(6.96, 6.96, 6.96) @ 3700 MHz; Calibrated: 2021/06/23
- Sensor-Surface: 1.4mm (Mechanical Surface Detection)
- Electronics: DAE4 Sn915; Calibrated: 2021/06/02
- Phantom: ELI Phantom\_1043; Type: QD OVA 002 Ax
- Measurement SW: DASY52, Version 52.10 (4); SEMCAD X Version 14.6.14 (7501)

**Pin=50mW/Area Scan (81x81x1):** Interpolated grid: dx=1.200 mm, dy=1.200 mm

Maximum value of SAR (interpolated) = 6.07 W/kg

**Pin=50mW/Zoom Scan (7x7x6)/Cube 0:** Measurement grid: dx=5mm, dy=5mm, dz=2.5mm

Reference Value = 46.27 V/m; Power Drift = 0.09 dB

Peak SAR (extrapolated) = 8.29 W/kg

**SAR(1 g) = 3.11 W/kg; SAR(10 g) = 1.17 W/kg** (SAR corrected for target medium)

Maximum value of SAR (measured) = 6.07 W/kg

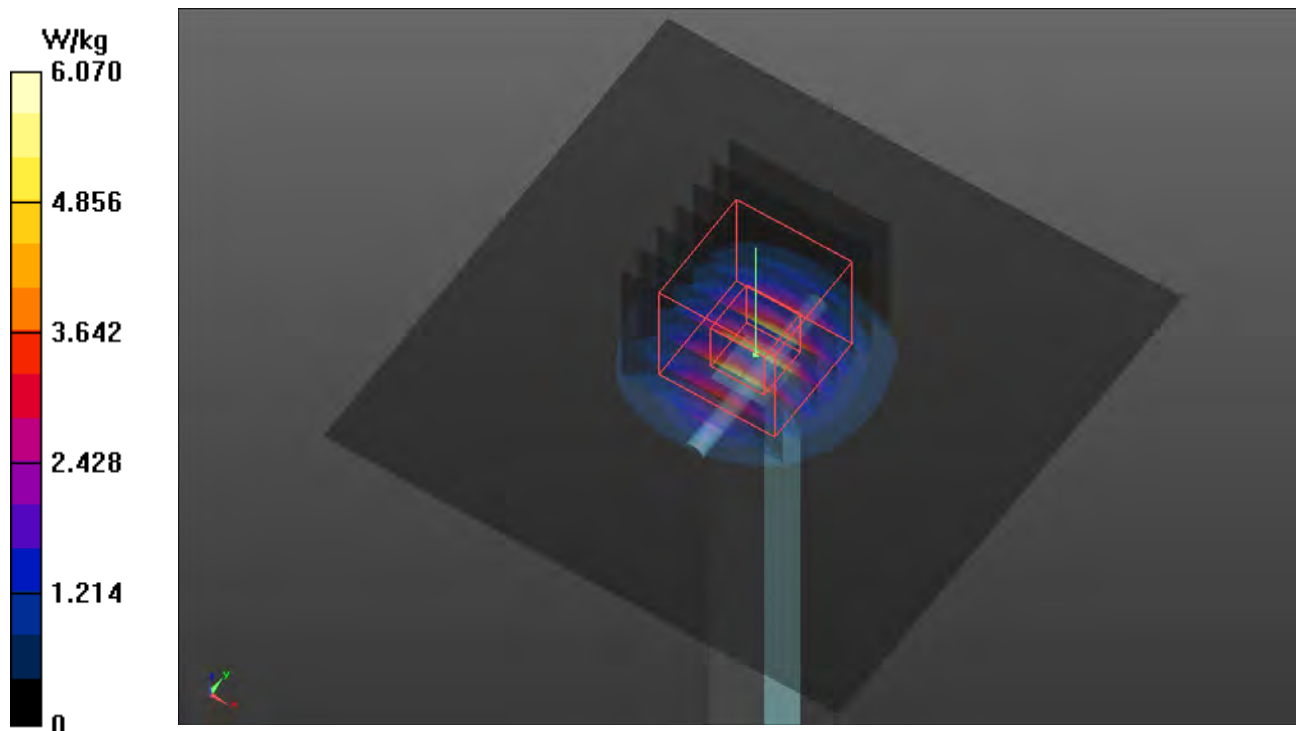

## Plots of System Verification

Test Laboratory: Bureau Veritas ADT SAR/HAC Testing Lab

Date: 2022/3/24

### S36 System Check\_H2450\_220324

DUT: Dipole 2450 MHz; Type: D2450V2; SN: 737

Communication System: UID 0, CW; Frequency: 2450 MHz; Duty Cycle: 1:1

Medium: H19T27N2\_0324 Medium parameters used:  $f = 2450$  MHz;  $\sigma = 1.79$  S/m;  $\epsilon_r = 37.777$ ;  $\rho = 1000$  kg/m<sup>3</sup>

Ambient Temperature : 23.7 °C ; Liquid Temperature : 23.3 °C

DASY5 Configuration:

- Probe: EX3DV4 - SN3578; ConvF(7.34, 7.34, 7.34) @ 2450 MHz; Calibrated: 2021/6/23
- Sensor-Surface: 1.4mm (Mechanical Surface Detection)
- Electronics: DAE4 Sn915; Calibrated: 2021/6/2
- Phantom: ELI Phantom\_1204; Type: QD OVA 002 Ax
- Measurement SW: DASY52, Version 52.10 (4); SEMCAD X Version 14.6.14 (7501)

**Pin=50mW/Area Scan (81x81x1):** Interpolated grid: dx=1.200 mm, dy=1.200 mm

Maximum value of SAR (interpolated) = 4.54 W/kg

**Pin=50mW/Zoom Scan (7x7x7)/Cube 0:** Measurement grid: dx=5mm, dy=5mm, dz=5mm

Reference Value = 48.57 V/m; Power Drift = 0.00 dB

Peak SAR (extrapolated) = 5.72 W/kg

**SAR(1 g) = 2.78 W/kg; SAR(10 g) = 1.32 W/kg** (SAR corrected for target medium)

Maximum value of SAR (measured) = 4.63 W/kg

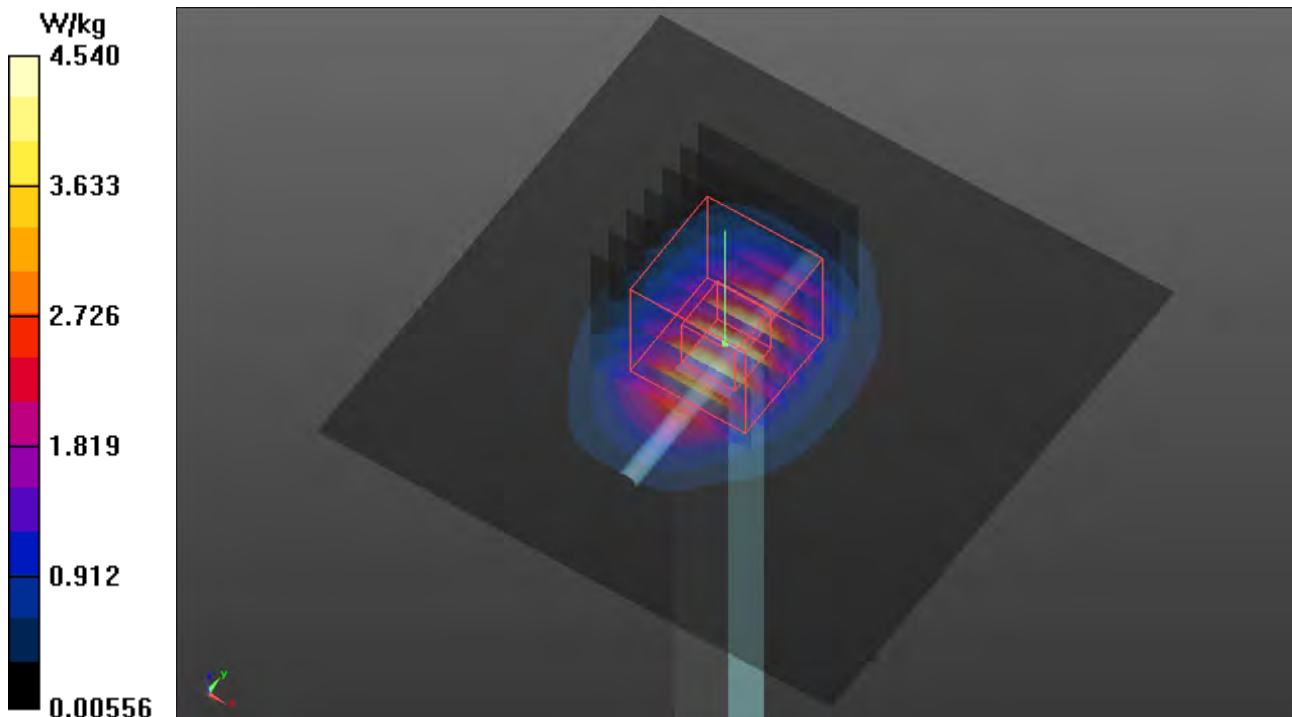

## Plots of System Verification

Test Laboratory: Bureau Veritas ADT SAR/HAC Testing Lab

Date: 2022/3/24

### S37 System Check\_H5250\_220324

DUT: Dipole 5 GHz; Type: D5GHzV2; SN: 1019

Communication System: UID 0, CW; Frequency: 5250 MHz; Duty Cycle: 1:1

Medium: H34T60N1\_0324 Medium parameters used (interpolated):  $f = 5250$  MHz;  $\sigma = 4.658$  S/m;  $\epsilon_r = 37.121$ ;  $\rho = 1000$  kg/m<sup>3</sup>

Ambient Temperature : 23.7 °C ; Liquid Temperature : 23.3 °C

DASY5 Configuration:

- Probe: EX3DV4 - SN3578; ConvF(5.39, 5.39, 5.39) @ 5250 MHz; Calibrated: 2021/6/23
- Sensor-Surface: 1.4mm (Mechanical Surface Detection)
- Electronics: DAE4 Sn915; Calibrated: 2021/6/2
- Phantom: ELI Phantom\_1204; Type: QD OVA 002 Ax
- Measurement SW: DASY52, Version 52.10 (4); SEMCAD X Version 14.6.14 (7501)

**Pin=50mW/Area Scan (91x91x1):** Interpolated grid: dx=1.000 mm, dy=1.000 mm

Maximum value of SAR (interpolated) = 9.98 W/kg

**Pin=50mW/Zoom Scan (7x7x7)/Cube 0:** Measurement grid: dx=4mm, dy=4mm, dz=1.4mm

Reference Value = 45.49 V/m; Power Drift = 0.03 dB

Peak SAR (extrapolated) = 16.0 W/kg

**SAR(1 g) = 4.22 W/kg; SAR(10 g) = 1.26 W/kg** (SAR corrected for target medium)

Maximum value of SAR (measured) = 10.3 W/kg

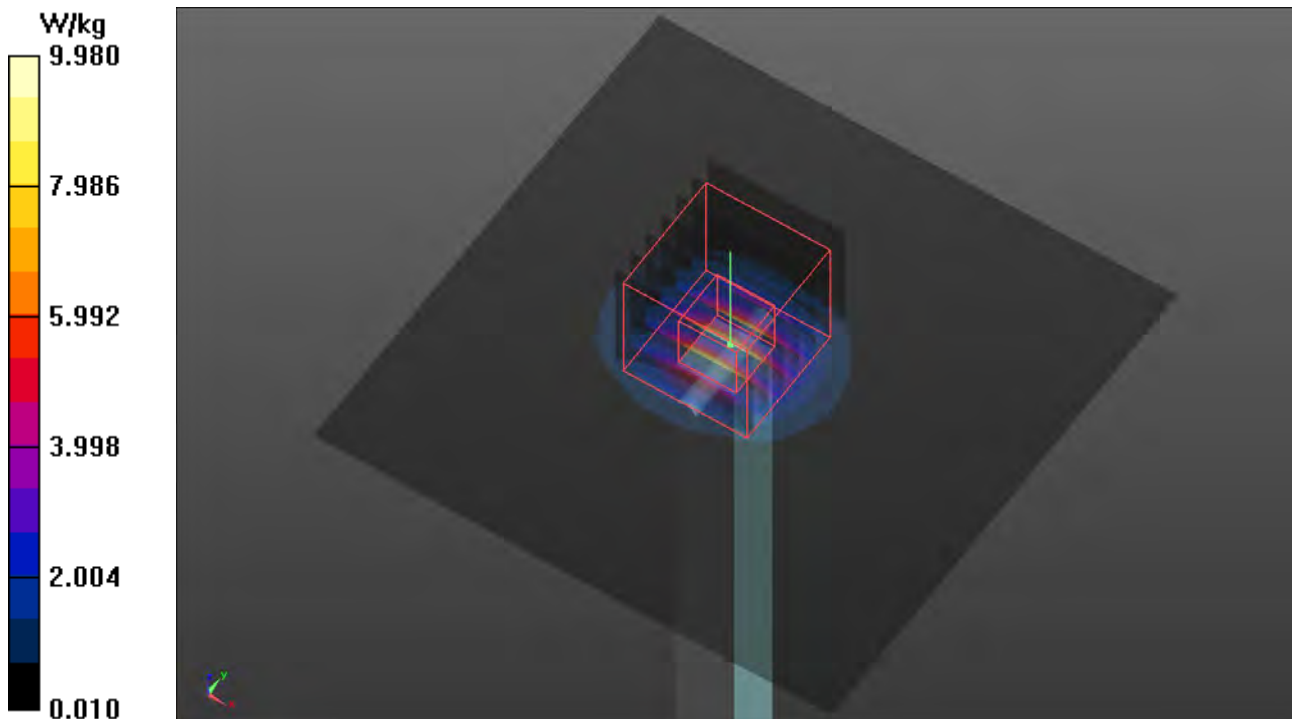

## Plots of System Verification

Test Laboratory: Bureau Veritas ADT SAR/HAC Testing Lab

Date: 2022/03/23

### S38 System Check\_H5600\_220323

DUT: Dipole 5 GHz; Type: D5GHzV2; SN: 1019

Communication System: UID 0, CW; Frequency: 5600 MHz; Duty Cycle: 1:1

Medium: H34T60N1\_0323 Medium parameters used:  $f = 5600$  MHz;  $\sigma = 5.188$  S/m;  $\epsilon_r = 36.135$ ;  $\rho = 1000$  kg/m<sup>3</sup>

Ambient Temperature : 23.6 °C ; Liquid Temperature : 23.1 °C

DASY5 Configuration:

- Probe: EX3DV4 - SN3578; ConvF(5, 5, 5) @ 5600 MHz; Calibrated: 2021/6/23
- Sensor-Surface: 1.4mm (Mechanical Surface Detection)
- Electronics: DAE4 Sn915; Calibrated: 2021/6/2
- Phantom: ELI Phantom\_1204; Type: QD OVA 002 Ax;
- Measurement SW: DASY52, Version 52.10 (4); SEMCAD X Version 14.6.14 (7501)

**Pin=50mW/Area Scan (91x91x1):** Interpolated grid:  $dx=1.000$  mm,  $dy=1.000$  mm

Maximum value of SAR (interpolated) = 10.300 W/kg

**Pin=50mW/Zoom Scan (7x7x7)/Cube 0:** Measurement grid:  $dx=4$ mm,  $dy=4$ mm,  $dz=1.4$ mm

Reference Value = 45.86 V/m; Power Drift = 0.06 dB

Peak SAR (extrapolated) = 17.9 W/kg

**SAR(1 g) = 4.16 W/kg; SAR(10 g) = 1.18 W/kg** (SAR corrected for target medium)

Maximum value of SAR (measured) = 10.6 W/kg

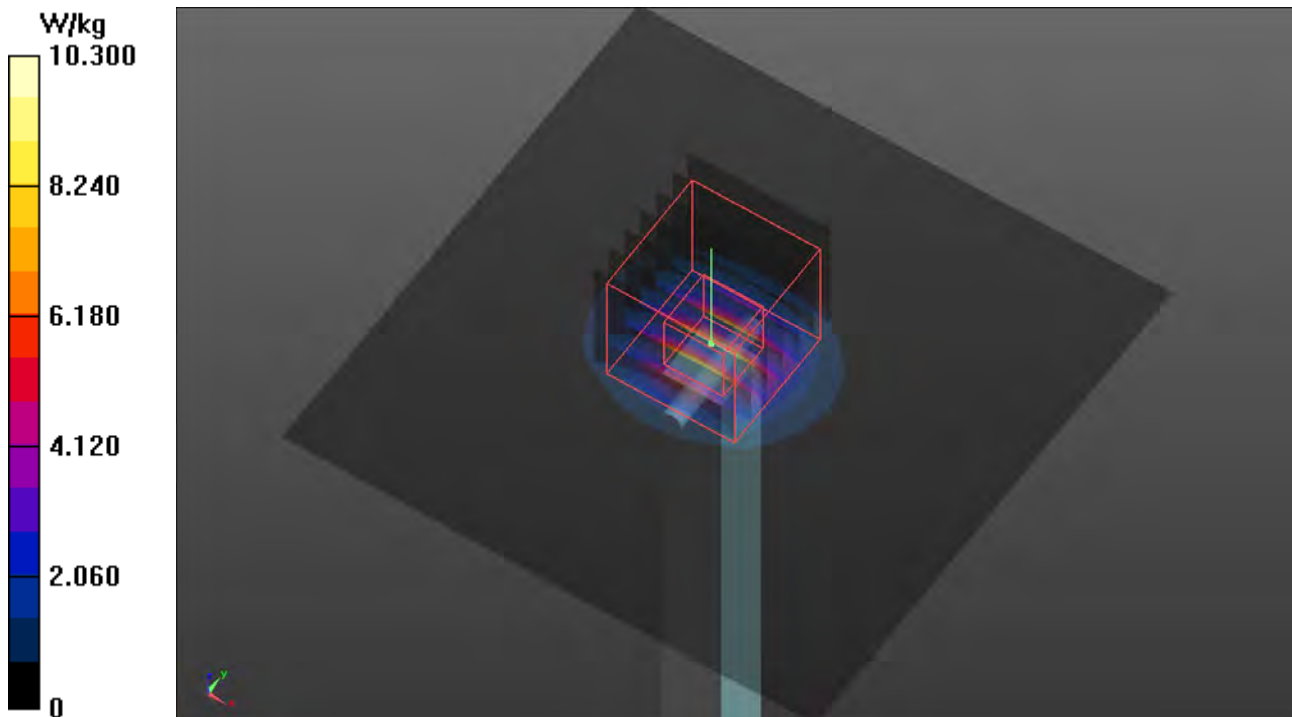

## Plots of System Verification

Test Laboratory: Bureau Veritas ADT SAR/HAC Testing Lab

Date: 2022/03/23

### S39 System Check\_H5750\_220323

DUT: Dipole 5 GHz; Type: D5GHzV2; SN: 1019

Communication System: UID 0, CW; Frequency: 5750 MHz; Duty Cycle: 1:1

Medium: H34T60N1\_0323 Medium parameters used:  $f = 5750$  MHz;  $\sigma = 5.363$  S/m;  $\epsilon_r = 35.849$ ;  $\rho = 1000$  kg/m<sup>3</sup>

Ambient Temperature : 23.6 °C ; Liquid Temperature : 23.1 °C

DASY5 Configuration:

- Probe: EX3DV4 - SN3578; ConvF(5.05, 5.05, 5.05) @ 5750 MHz; Calibrated: 2021/6/23
- Sensor-Surface: 1.4mm (Mechanical Surface Detection)
- Electronics: DAE4 Sn915; Calibrated: 2021/6/2
- Phantom: ELI Phantom\_1204; Type: QD OVA 002 Ax;
- Measurement SW: DASY52, Version 52.10 (4); SEMCAD X Version 14.6.14 (7501)

**Pin=50mW/Area Scan (91x91x1):** Interpolated grid: dx=1.000 mm, dy=1.000 mm

Maximum value of SAR (interpolated) = 10.200 W/kg

**Pin=50mW/Zoom Scan (7x7x7)/Cube 0:** Measurement grid: dx=4mm, dy=4mm, dz=1.4mm

Reference Value = 43.12 V/m; Power Drift = 0.06 dB

Peak SAR (extrapolated) = 18.0 W/kg

**SAR(1 g) = 4.13 W/kg; SAR(10 g) = 1.23 W/kg** (SAR corrected for target medium)

Maximum value of SAR (measured) = 10.6 W/kg

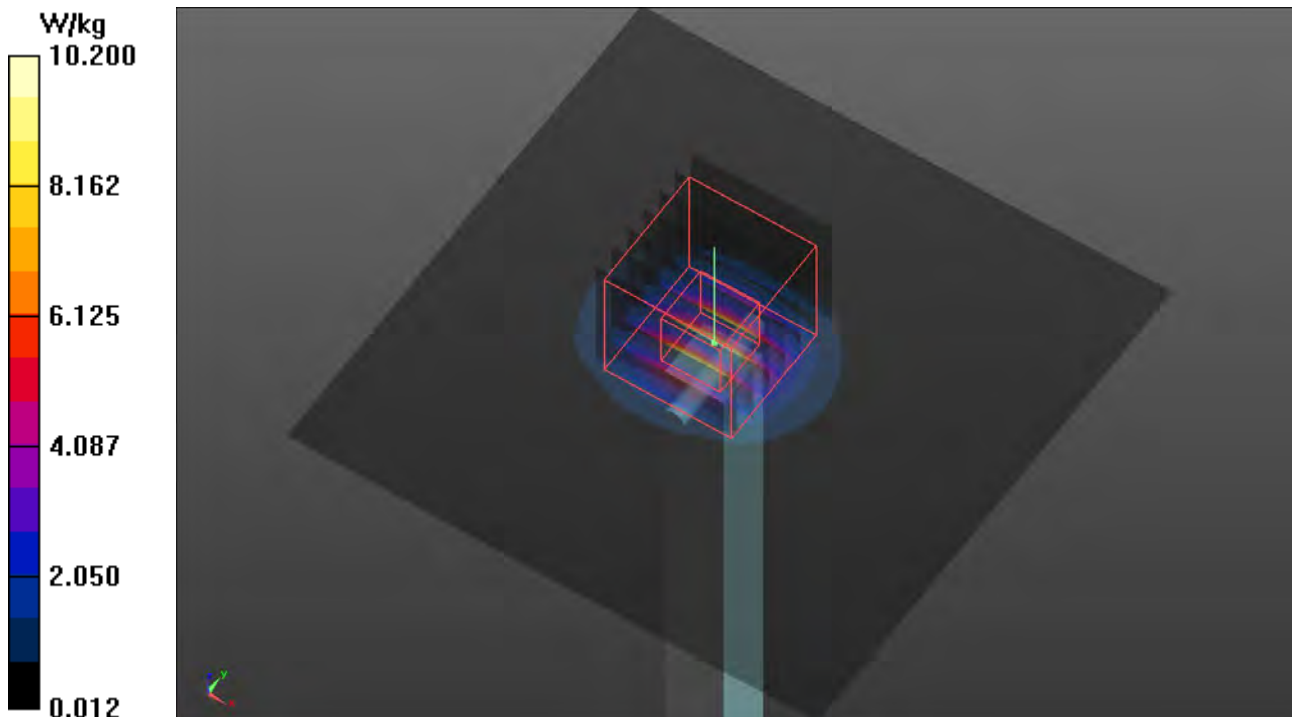

## Plots of System Verification

Test Laboratory: Bureau Veritas ADT SAR/HAC Testing Lab

Date: 2022/3/24

### S40 System Check\_H2450\_220324

DUT: Dipole 2450 MHz; Type: D2450V2; SN: 737

Communication System: UID 0, CW; Frequency: 2450 MHz; Duty Cycle: 1:1

Medium: H19T27N2\_0324 Medium parameters used:  $f = 2450$  MHz;  $\sigma = 1.79$  S/m;  $\epsilon_r = 37.777$ ;  $\rho = 1000$  kg/m<sup>3</sup>

Ambient Temperature : 23.7 °C ; Liquid Temperature : 23.3 °C

DASY5 Configuration:

- Probe: EX3DV4 - SN3578; ConvF(7.34, 7.34, 7.34) @ 2450 MHz; Calibrated: 2021/6/23
- Sensor-Surface: 1.4mm (Mechanical Surface Detection)
- Electronics: DAE4 Sn915; Calibrated: 2021/6/2
- Phantom: ELI Phantom\_1204; Type: QD OVA 002 Ax
- Measurement SW: DASY52, Version 52.10 (4); SEMCAD X Version 14.6.14 (7501)

**Pin=50mW/Area Scan (81x81x1):** Interpolated grid: dx=1.200 mm, dy=1.200 mm

Maximum value of SAR (interpolated) = 4.54 W/kg

**Pin=50mW/Zoom Scan (7x7x7)/Cube 0:** Measurement grid: dx=5mm, dy=5mm, dz=5mm

Reference Value = 48.57 V/m; Power Drift = 0.00 dB

Peak SAR (extrapolated) = 5.72 W/kg

**SAR(1 g) = 2.78 W/kg; SAR(10 g) = 1.32 W/kg** (SAR corrected for target medium)

Maximum value of SAR (measured) = 4.63 W/kg

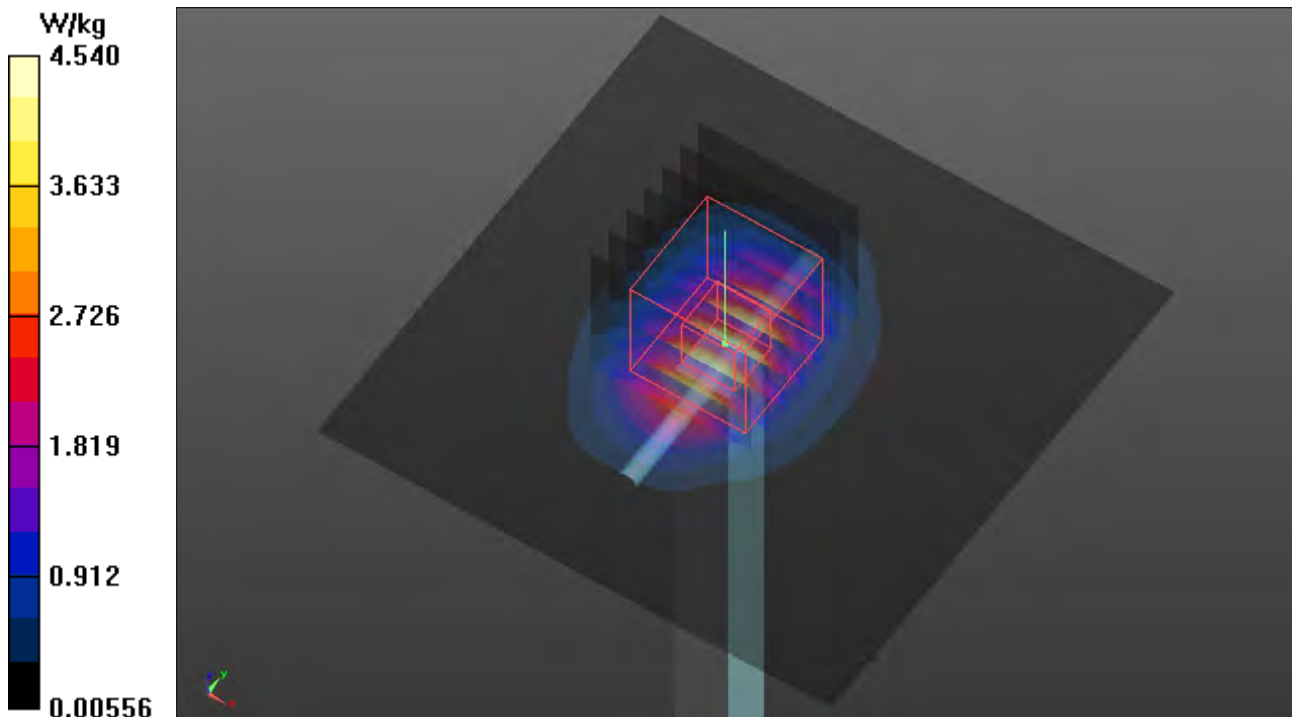



# Plots of System Verification

## Measurement Report S41S System Check\_H6500\_220505 Device under Test Properties

Model, Manufacturer	Dimensions [mm]	IMEI	DUT Type
Device,	50.0 x 10.0 x 8.0		

## Exposure Conditions

Phantom Section, TSL	Position, Test Distance [mm]	Band	Group, UID	Frequency [MHz], Channel Number	Conversion Factor	TSL Conductivity [S/m]	TSL Permittivity
Flat, HSL				6500.0	5.6	6.17	33.8

## Hardware Setup

Phantom	TSL, Measured Date	Probe, Calibration Date	DAE, Calibration Date
ELI V5.0 (20deg probe tilt) - 1245	H50T72N1, 2022-May-05	EX3DV4 - SN3650, 2022-03-24	DAE4 Sn1341, 2021-08-20

## Scan Setup

	Area Scan	Zoom Scan
Grid Extents [mm]	45.0 x 90.0	22.0 x 22.0 x 22.0
Grid Steps [mm]	7.5 x 7.5	3.4 x 3.4 x 1.4
Sensor Surface [mm]	3.0	1.4

## Measurement Results

	Area Scan	Zoom Scan
Date	2022-05-05	2022-05-05
psSAR1g [W/Kg]	25.0	29.1
psSAR10g [W/Kg]	5.04	5.39
Power Drift [dB]	-0.08	-0.03

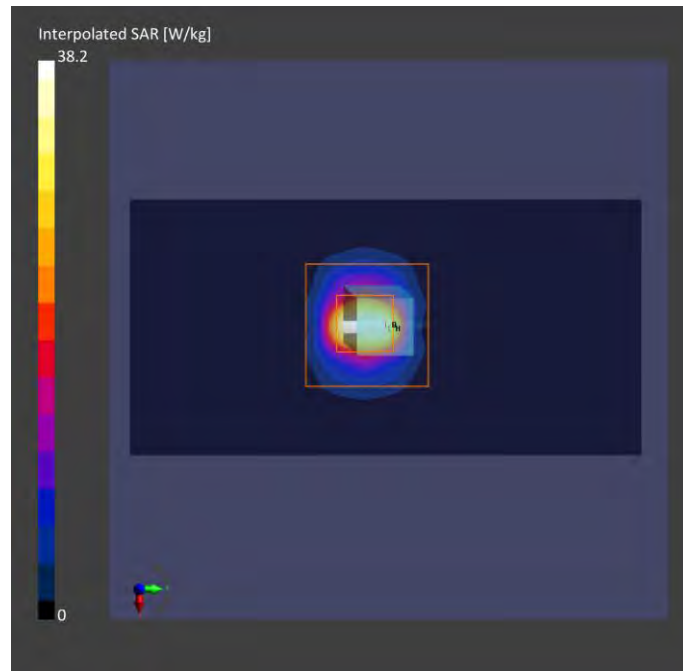

# Plots of System Verification

Test Lab: Bureau Veritas ADT SAR/HAC/PD Testing Lab

Power Density Plot No.:

S41P\_PD\_System Check\_10 GHz\_2022.05.05

## Device under Test Properties

Name, Manufacturer	Dimensions [mm]	IMEI	DUT Type
SPEAG, 5G Verification Source	100.0 x 100.0 x 170.0	SN: 1025	

## Exposure Conditions

Phantom Section	Position, Test Distance [mm]	Band	Group, UID	Frequency [MHz], Channel Number	Conversion Factor
5GAir	FRONT 5.55	Validation band	CW 0	10000.0 10000	1.0

## Hardware Setup

Phantom	Medium	Probe, Calibration Date	DAE, Calibration Date
mmWave	Air---	EUmmWV4 - SN9438_F1-55GHz, 2021-07-26	DAE4 Sn1341, 2021-08-20

## Scan Setup

	5G Scan
Grid Extents [mm]	120.0 x 120.0
Grid Steps [lambda]	0.25 x 0.25
Sensor Surface [mm]	5.55

## Measurement Results

	5G Scan
Date	2022-05-05
Avg. Area [cm <sup>2</sup> ]	4.00
pStotavg[W/m <sup>2</sup> ]	53.3
pSnavg [W/m <sup>2</sup> ]	53.2
E <sub>peak</sub> [V/m]	148
Power Drift [dB]	0.03

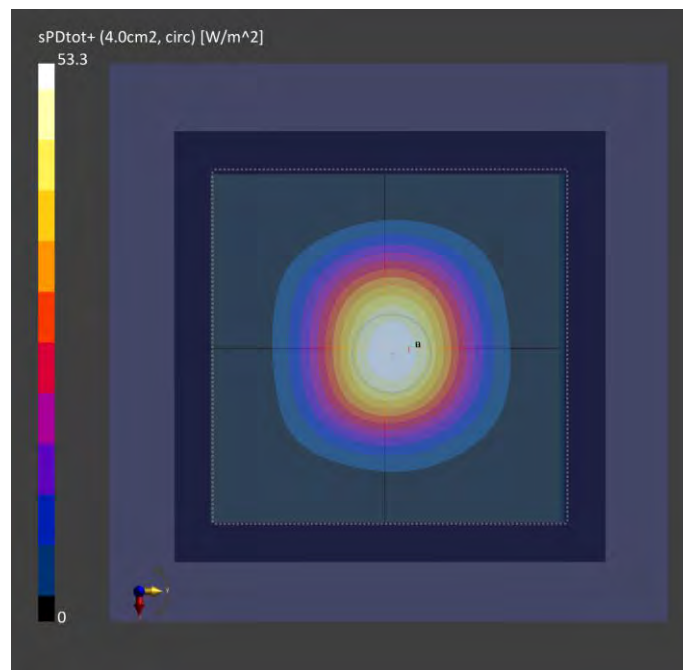

### Annex B. Plots of Measurement

The SAR plots for highest measured SAR in each exposure configuration, wireless mode and frequency band combination are shown as follows.

## Plots of Measurement

Test Laboratory: Bureau Veritas ADT SAR/HAC Testing Lab

Date: 2022/3/24

### P01 WCDMA II\_RMC12.2K\_Bottom for Laptop\_0mm\_Ch9400\_Ant 0\_Power Reduction\_w

DUT: BFLF-WTW-P22030373

Communication System: UID 10011 - CAB, UMTS-FDD (WCDMA); Frequency: 1880 MHz; Duty Cycle: 1:1.95  
 Medium: H16T20N1\_0324 Medium parameters used:  $f = 1880$  MHz;  $\sigma = 1.45$  S/m;  $\epsilon_r = 38.777$ ;  $\rho = 1000$  kg/m<sup>3</sup>  
 Ambient Temperature : 23.7 °C ; Liquid Temperature : 23.3 °C

#### DASY5 Configuration:

- Probe: EX3DV4 - SN3578; ConvF(7.82, 7.82, 7.82) @ 1880 MHz; Calibrated: 2021/6/23
- Sensor-Surface: 1.4mm (Mechanical Surface Detection)
- Electronics: DAE4 Sn915; Calibrated: 2021/6/2
- Phantom: ELI Phantom\_1204; Type: QD OVA 002 Ax;
- Measurement SW: DASY52, Version 52.10 (4); SEMCAD X Version 14.6.14 (7501)

**Area Scan (71x261x1):** Interpolated grid: dx=1.500 mm, dy=1.500 mm  
 Maximum value of SAR (interpolated) = 0.803 W/kg

**Zoom Scan (5x5x7)/Cube 0:** Measurement grid: dx=8mm, dy=8mm, dz=5mm

Reference Value = 21.29 V/m; Power Drift = -0.05 dB

Peak SAR (extrapolated) = 1.18 W/kg

**SAR(1 g) = 0.579 W/kg; SAR(10 g) = 0.305 W/kg** (SAR corrected for target medium)

Smallest distance from peaks to all points 3 dB below = 11.3 mm

Ratio of SAR at M2 to SAR at M1 = 50.9%

Maximum value of SAR (measured) = 0.946 W/kg

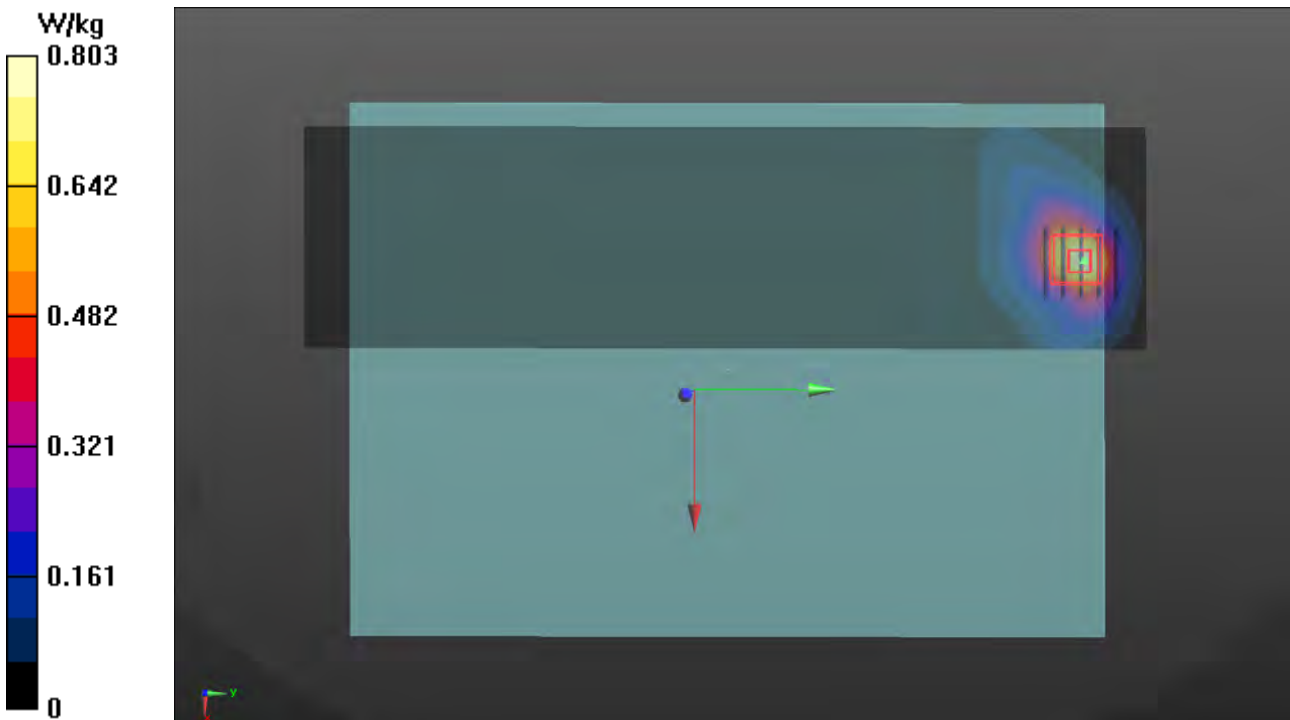

## Plots of Measurement

Test Laboratory: Bureau Veritas ADT SAR/HAC Testing Lab

Date: 2022/3/25

### P02 WCDMA IV\_RMC12.2K\_Bottom for Laptop\_0mm\_Ch1312\_Ant 0\_Power Reduction\_w

DUT: BFLF-WTW-P22030373

Communication System: UID 10011 - CAB, UMTS-FDD (WCDMA); Frequency: 1712.4 MHz; Duty Cycle: 1:1.95  
Medium: H16T20N1\_0325 Medium parameters used (interpolated):  $f = 1712.4$  MHz;  $\sigma = 1.284$  S/m;  $\epsilon_r = 40.407$ ;  $\rho = 1000$  kg/m<sup>3</sup>

Ambient Temperature : 23.6 °C ; Liquid Temperature : 23.4 °C

DASY5 Configuration:

- Probe: EX3DV4 - SN3578; ConvF(8.09, 8.09, 8.09) @ 1712.4 MHz; Calibrated: 2021/6/23
- Sensor-Surface: 1.4mm (Mechanical Surface Detection)
- Electronics: DAE4 Sn915; Calibrated: 2021/6/2
- Phantom: ELI Phantom\_1204; Type: QD OVA 002 Ax;
- Measurement SW: DASY52, Version 52.10 (4); SEMCAD X Version 14.6.14 (7501)

**Area Scan (71x261x1):** Interpolated grid: dx=1.500 mm, dy=1.500 mm  
Maximum value of SAR (interpolated) = 0.765 W/kg

**Zoom Scan (5x5x7)/Cube 0:** Measurement grid: dx=8mm, dy=8mm, dz=5mm

Reference Value = 23.50 V/m; Power Drift = -0.02 dB

Peak SAR (extrapolated) = 1.12 W/kg

**SAR(1 g) = 0.473 W/kg; SAR(10 g) = 0.230 W/kg** (SAR corrected for target medium)

Smallest distance from peaks to all points 3 dB below = 12.9 mm

Ratio of SAR at M2 to SAR at M1 = 52.9%

Maximum value of SAR (measured) = 0.919 W/kg

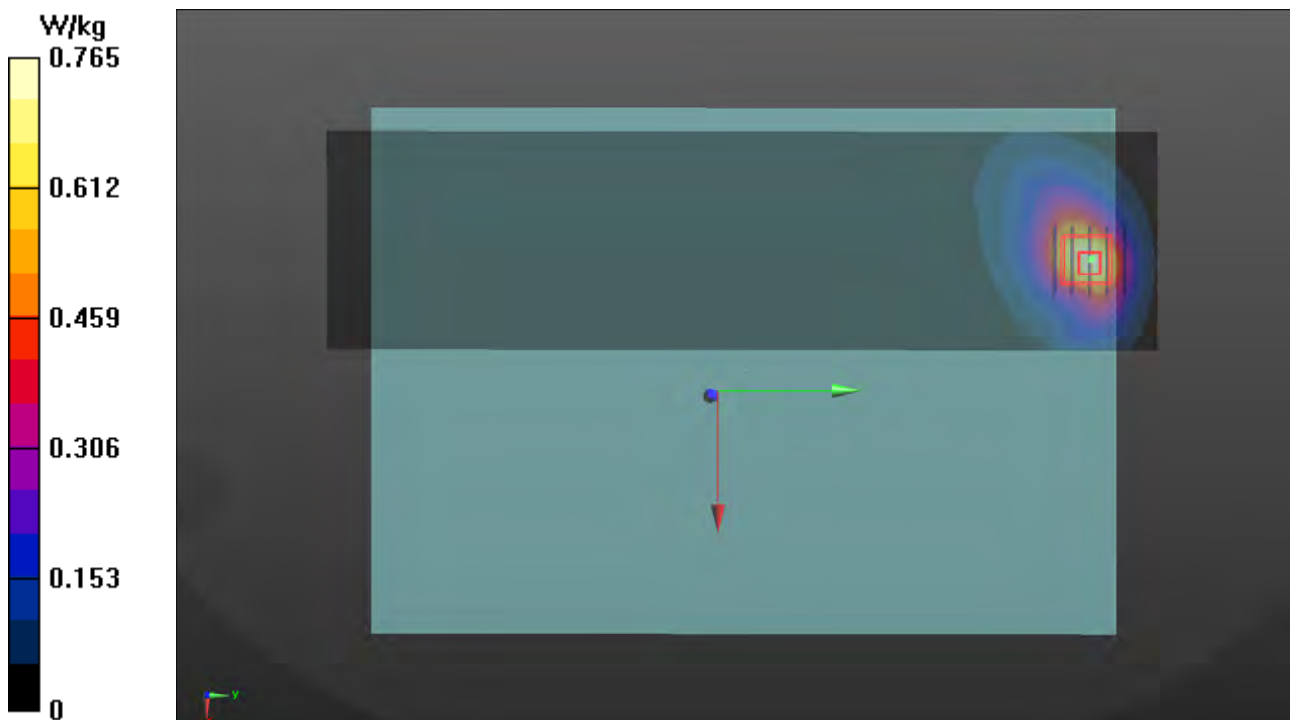

## Plots of Measurement

Test Laboratory: Bureau Veritas ADT SAR/HAC Testing Lab

Date: 2022/3/25

### P03 WCDMA V\_RMC12.2K\_Bottom for Laptop\_0mm\_Ch4132\_Ant 0\_Power Reduction\_w

DUT: BFLF-WTW-P22030373

Communication System: UID 10011 - CAB, UMTS-FDD (WCDMA); Frequency: 826.4 MHz; Duty Cycle: 1:1.95  
 Medium: H07T10N1\_0325 Medium parameters used (interpolated):  $f = 826.4$  MHz;  $\sigma = 0.931$  S/m;  $\epsilon_r = 40.409$ ;  $\rho = 1000$  kg/m<sup>3</sup>

Ambient Temperature : 23.6 °C ; Liquid Temperature : 23.4 °C

DASY5 Configuration:

- Probe: EX3DV4 - SN3578; ConvF(9.54, 9.54, 9.54) @ 826.4 MHz; Calibrated: 2021/6/23
- Sensor-Surface: 1.4mm (Mechanical Surface Detection)
- Electronics: DAE4 Sn915; Calibrated: 2021/6/2
- Phantom: ELI Phantom\_1204; Type: QD OVA 002 Ax;
- Measurement SW: DASY52, Version 52.10 (4); SEMCAD X Version 14.6.14 (7501)

**Area Scan (71x261x1):** Interpolated grid: dx=1.500 mm, dy=1.500 mm  
 Maximum value of SAR (interpolated) = 0.380 W/kg

**Zoom Scan (5x5x7)/Cube 0:** Measurement grid: dx=8mm, dy=8mm, dz=5mm

Reference Value = 20.24 V/m; Power Drift = -0.04 dB

Peak SAR (extrapolated) = 0.416 W/kg

**SAR(1 g) = 0.236 W/kg; SAR(10 g) = 0.143 W/kg** (SAR corrected for target medium)

Smallest distance from peaks to all points 3 dB below = 14.8 mm

Ratio of SAR at M2 to SAR at M1 = 60.8%

Maximum value of SAR (measured) = 0.328 W/kg

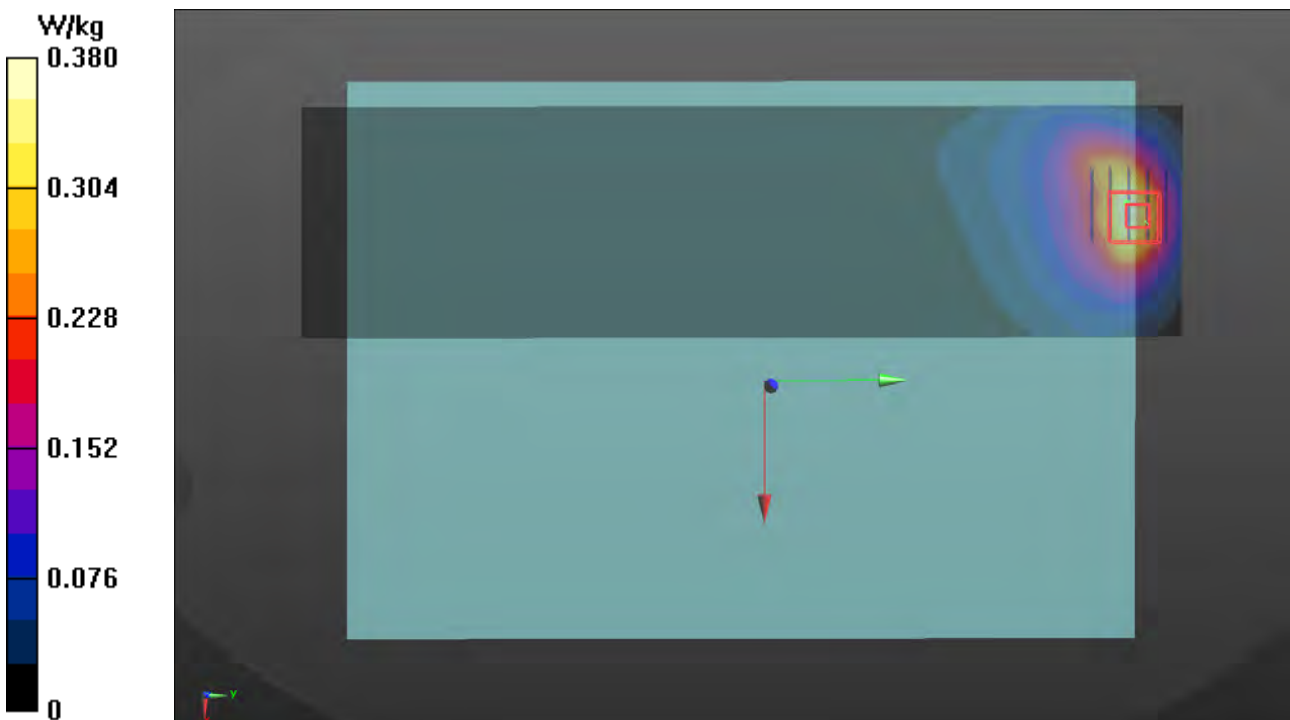

## Plots of Measurement

Test Laboratory: Bureau Veritas ADT SAR/HAC Testing Lab

Date: 2022/3/24

### P04 LTE 2\_QPSK20M\_Bottom For Laptop\_0mm\_Ch18700\_1RB\_OS0\_Ant 0\_Power Reduction\_w

DUT: BFLF-WTW-P22030373

Communication System: UID 10169 - CAE, LTE-FDD (SC-FDMA, 1 RB, 20 MHz, QPSK); Frequency: 1860 MHz; Duty Cycle: 1:3.74

Medium: H16T20N1\_0324 Medium parameters used:  $f = 1860$  MHz;  $\sigma = 1.438$  S/m;  $\epsilon_r = 38.83$ ;  $\rho = 1000$  kg/m<sup>3</sup>

Ambient Temperature : 23.7 °C ; Liquid Temperature : 23.3 °C

DASY5 Configuration:

- Probe: EX3DV4 - SN3578; ConvF(7.82, 7.82, 7.82) @ 1860 MHz; Calibrated: 2021/6/23
- Sensor-Surface: 1.4mm (Mechanical Surface Detection)
- Electronics: DAE4 Sn915; Calibrated: 2021/6/2
- Phantom: ELI Phantom\_1204; Type: QD OVA 002 Ax;
- Measurement SW: DASY52, Version 52.10 (4); SEMCAD X Version 14.6.14 (7501)

**Area Scan (71x261x1):** Interpolated grid: dx=1.500 mm, dy=1.500 mm

Maximum value of SAR (interpolated) = 1.020 W/kg

**Zoom Scan (5x5x7)/Cube 0:** Measurement grid: dx=8mm, dy=8mm, dz=5mm

Reference Value = 24.31 V/m; Power Drift = -0.10 dB

Peak SAR (extrapolated) = 1.51 W/kg

**SAR(1 g) = 0.626 W/kg; SAR(10 g) = 0.394 W/kg** (SAR corrected for target medium)

Smallest distance from peaks to all points 3 dB below = 11.3 mm

Ratio of SAR at M2 to SAR at M1 = 50.8%

Maximum value of SAR (measured) = 1.21 W/kg

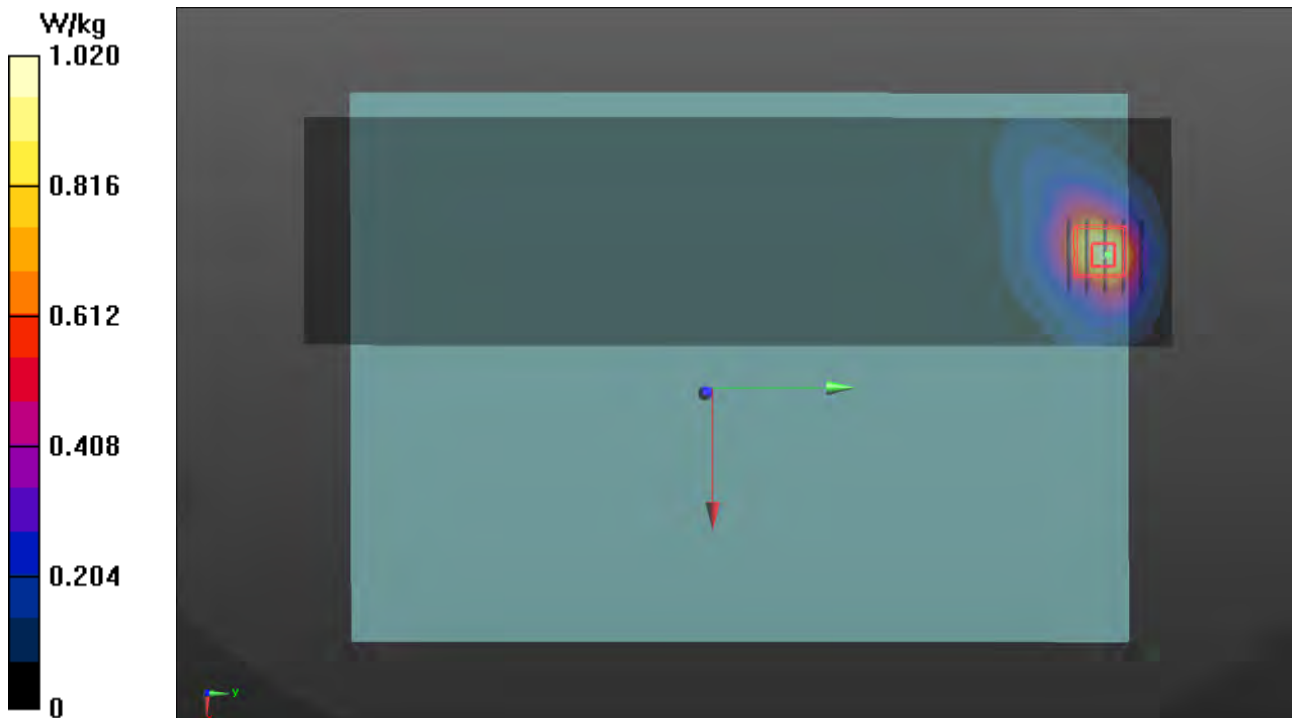

## Plots of Measurement

Test Laboratory: Bureau Veritas ADT SAR/HAC Testing Lab

Date: 2022/3/25

### P05 LTE 4\_QPSK20M\_Bottom for Laptop\_0mm\_Ch20050\_1RB\_OS0\_Ant 0\_Power Reduction\_w

DUT: BFLF-WTW-P22030373

Communication System: UID 10169 - CAE, LTE-FDD (SC-FDMA, 1 RB, 20 MHz, QPSK); Frequency: 1720 MHz; Duty Cycle: 1:3.74

Medium: H16T20N1\_0325 Medium parameters used:  $f = 1720$  MHz;  $\sigma = 1.292$  S/m;  $\epsilon_r = 40.374$ ;  $\rho = 1000$  kg/m<sup>3</sup>

Ambient Temperature : 23.6 °C ; Liquid Temperature : 23.4 °C

DASY5 Configuration:

- Probe: EX3DV4 - SN3578; ConvF(8.09, 8.09, 8.09) @ 1720 MHz; Calibrated: 2021/6/23
- Sensor-Surface: 1.4mm (Mechanical Surface Detection)
- Electronics: DAE4 Sn915; Calibrated: 2021/6/2
- Phantom: ELI Phantom\_1204; Type: QD OVA 002 Ax;
- Measurement SW: DASY52, Version 52.10 (4); SEMCAD X Version 14.6.14 (7501)

**Area Scan (71x261x1):** Interpolated grid: dx=1.500 mm, dy=1.500 mm

Maximum value of SAR (interpolated) = 0.797 W/kg

**Zoom Scan (5x5x7)/Cube 0:** Measurement grid: dx=8mm, dy=8mm, dz=5mm

Reference Value = 23.12 V/m; Power Drift = -0.05 dB

Peak SAR (extrapolated) = 1.14 W/kg

**SAR(1 g) = 0.629 W/kg; SAR(10 g) = 0.343 W/kg** (SAR corrected for target medium)

Smallest distance from peaks to all points 3 dB below = 12.2 mm

Ratio of SAR at M2 to SAR at M1 = 53.7%

Maximum value of SAR (measured) = 0.917 W/kg

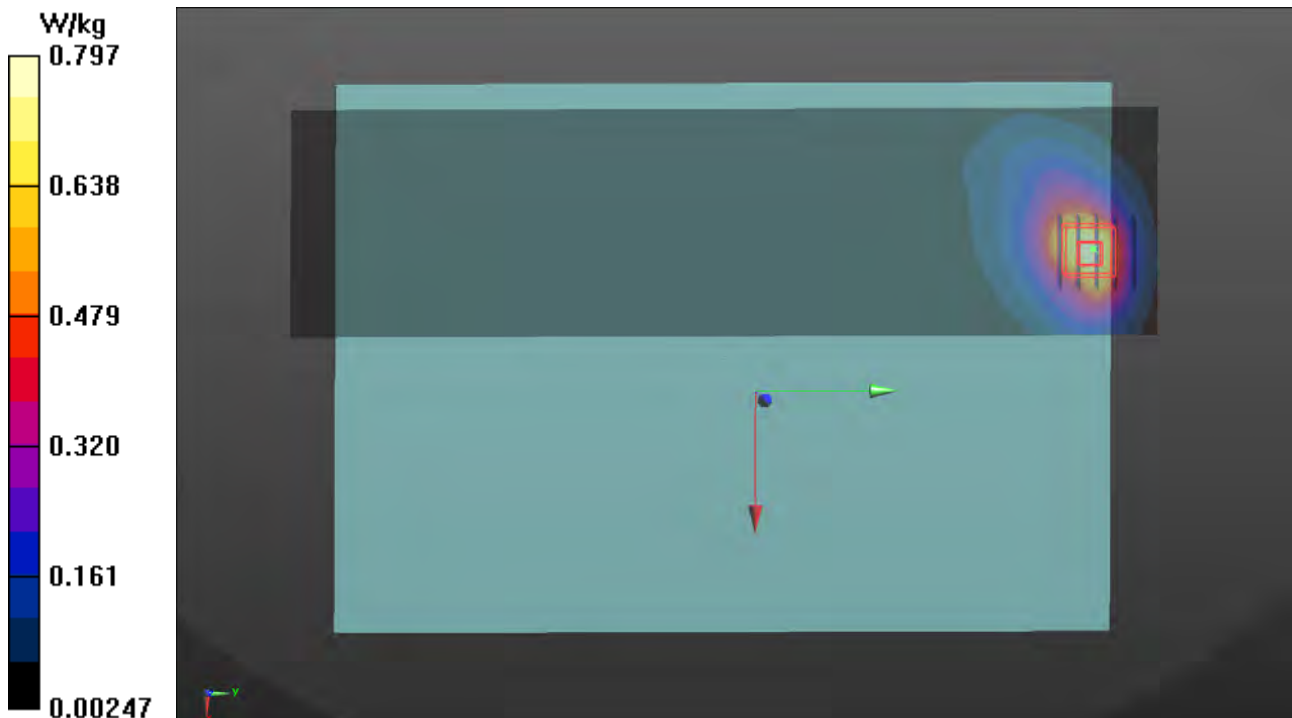



## Plots of Measurement

Test Laboratory: Bureau Veritas ADT SAR/HAC Testing Lab

Date: 2022/3/25

### P06 LTE 5\_QPSK10M\_Bottom for Laptop\_0mm\_Ch20525\_1RB\_OS0\_Ant 0\_Power Reduction\_w

DUT: BFLF-WTW-P22030373

Communication System: UID 10175 - CAG, LTE-FDD (SC-FDMA, 1 RB, 10 MHz, QPSK); Frequency: 836.5 MHz; Duty Cycle: 1:3.74

Medium: H07T10N1\_0325 Medium parameters used (interpolated):  $f = 836.5$  MHz;  $\sigma = 0.934$  S/m;  $\epsilon_r = 40.368$ ;  $\rho = 1000$  kg/m<sup>3</sup>

Ambient Temperature : 23.6 °C ; Liquid Temperature : 23.4 °C

DASY5 Configuration:

- Probe: EX3DV4 - SN3578; ConvF(9.54, 9.54, 9.54) @ 836.5 MHz; Calibrated: 2021/6/23
- Sensor-Surface: 1.4mm (Mechanical Surface Detection)
- Electronics: DAE4 Sn915; Calibrated: 2021/6/2
- Phantom: ELI Phantom\_1204; Type: QD OVA 002 Ax;
- Measurement SW: DASY52, Version 52.10 (4); SEMCAD X Version 14.6.14 (7501)

**Area Scan (71x261x1):** Interpolated grid: dx=1.500 mm, dy=1.500 mm  
Maximum value of SAR (interpolated) = 0.738 W/kg

**Zoom Scan (5x5x7)/Cube 0:** Measurement grid: dx=8mm, dy=8mm, dz=5mm

Reference Value = 28.81 V/m; Power Drift = -0.03 dB

Peak SAR (extrapolated) = 0.910 W/kg

**SAR(1 g) = 0.511 W/kg; SAR(10 g) = 0.311 W/kg** (SAR corrected for target medium)

Smallest distance from peaks to all points 3 dB below = 16 mm

Ratio of SAR at M2 to SAR at M1 = 58.2%

Maximum value of SAR (measured) = 0.764 W/kg

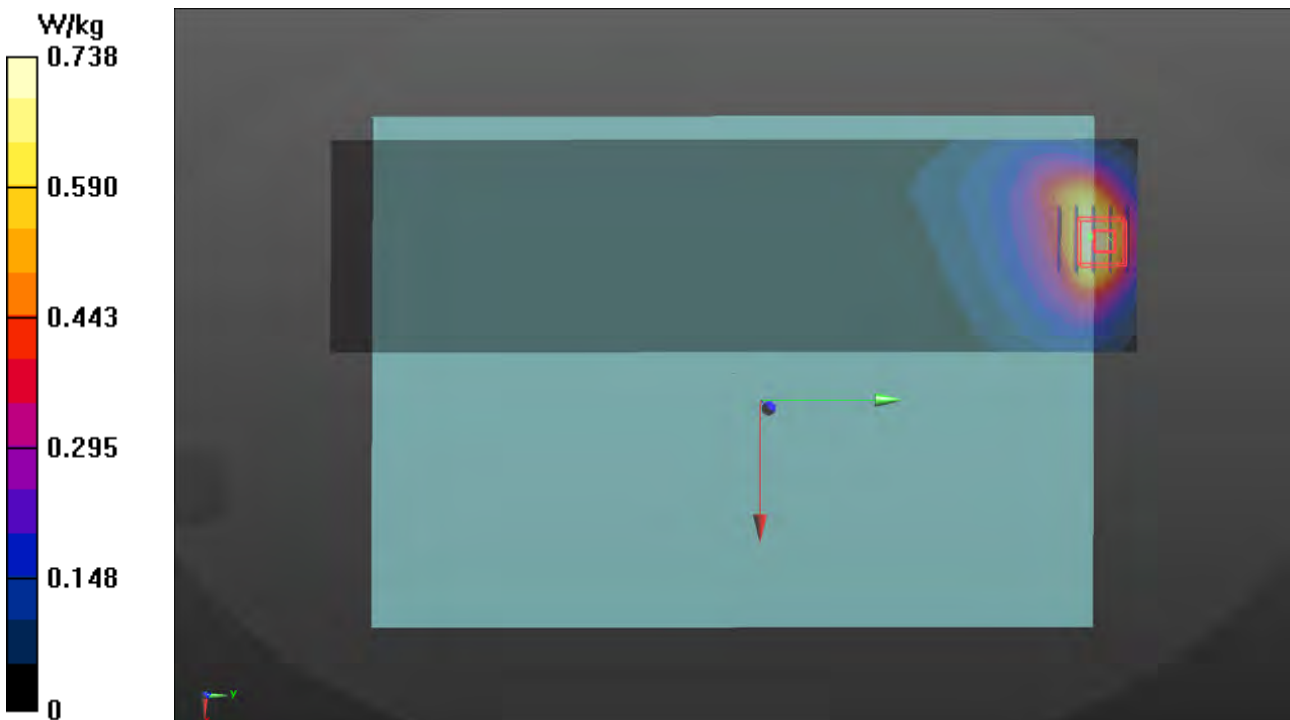

## Plots of Measurement

Test Laboratory: Bureau Veritas ADT SAR/HAC Testing Lab

Date: 2022/03/29

**P07 LTE 7\_QPSK20M\_Bottom for Laptop\_0mm\_Ch21350\_1RB\_OS0\_Ant 0\_Power Reduction\_w**

**DUT: BFLF-WTW-P22030373**

Communication System: UID 10169 - CAE, LTE-FDD (SC-FDMA, 1 RB, 20 MHz, QPSK); Frequency: 2560 MHz; Duty Cycle: 1:3.74

Medium: H19T27N3\_0329 Medium parameters used:  $f = 2560$  MHz;  $\sigma = 1.882$  S/m;  $\epsilon_r = 37.92$ ;  $\rho = 1000$  kg/m<sup>3</sup>

Ambient Temperature : 23.4 °C ; Liquid Temperature : 23.3 °C

DASY5 Configuration:

- Probe: EX3DV4 - SN3578; ConvF(7.22, 7.22, 7.22) @ 2560 MHz; Calibrated: 2021/06/23
- Sensor-Surface: 1.4mm (Mechanical Surface Detection)
- Electronics: DAE4 Sn915; Calibrated: 2021/06/02
- Phantom: ELI Phantom\_1043; Type: QD OVA 002 Ax;
- Measurement SW: DASY52, Version 52.10 (4); SEMCAD X Version 14.6.14 (7501)

**Area Scan (91x321x1):** Interpolated grid: dx=1.200 mm, dy=1.200 mm

Maximum value of SAR (interpolated) = 0.959 W/kg

**Zoom Scan (7x7x7)/Cube 0:** Measurement grid: dx=5mm, dy=5mm, dz=5mm

Reference Value = 22.16 V/m; Power Drift = -0.11 dB

Peak SAR (extrapolated) = 1.21 W/kg

**SAR(1 g) = 0.579 W/kg; SAR(10 g) = 0.315 W/kg** (SAR corrected for target medium)

Smallest distance from peaks to all points 3 dB below = 13.4 mm

Ratio of SAR at M2 to SAR at M1 = 45%

Maximum value of SAR (measured) = 0.950 W/kg

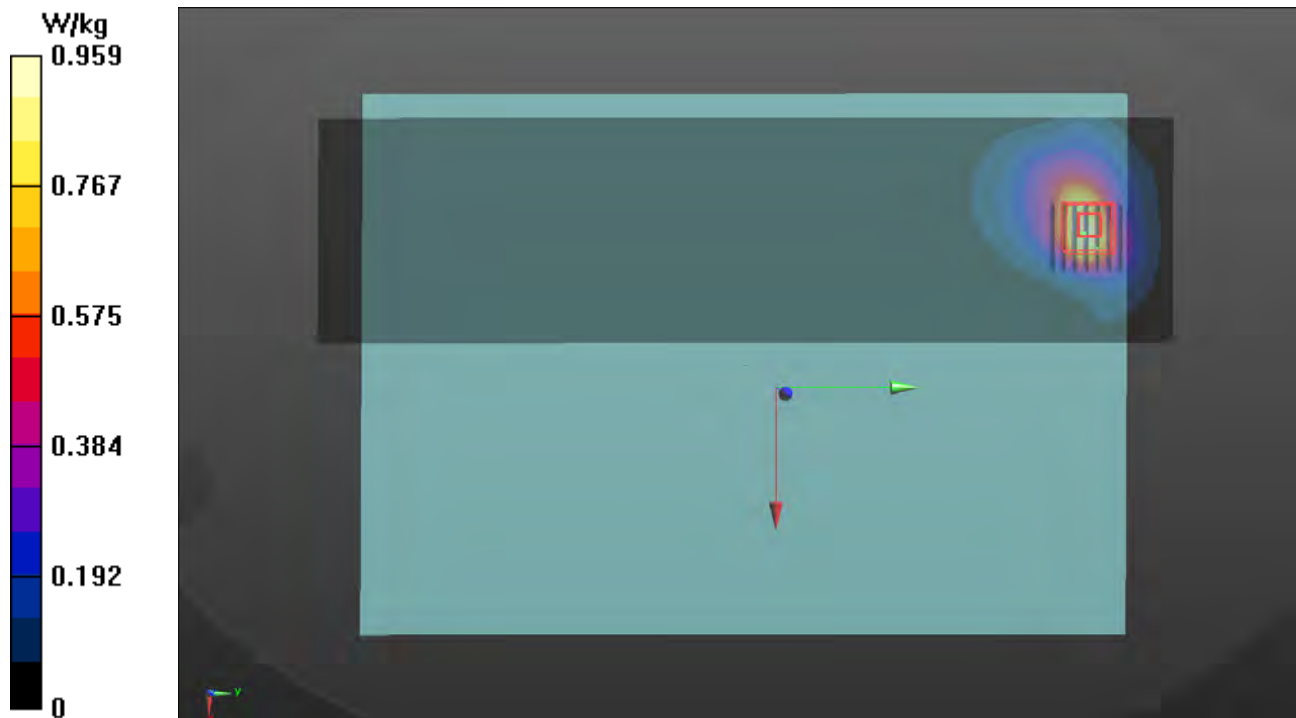

## Plots of Measurement

Test Laboratory: Bureau Veritas ADT SAR/HAC Testing Lab

Date: 2022/03/28

**P08 LTE 12\_QPSK10M\_Bottom for Laptop\_0mm\_Ch23130\_1RB\_OS0\_Ant 0\_Power Reduction\_w**

**DUT: BFLF-WTW-P22030373**

Communication System: UID 10175 - CAG, LTE-FDD (SC-FDMA, 1 RB, 10 MHz, QPSK); Frequency: 711 MHz; Duty Cycle: 1:3.74

Medium: H06T09N1\_0328 Medium parameters used:  $f = 711$  MHz;  $\sigma = 0.887$  S/m;  $\epsilon_r = 41.682$ ;  $\rho = 1000$  kg/m<sup>3</sup>

Ambient Temperature : 23.8 °C ; Liquid Temperature : 23.4 °C

DASY5 Configuration:

- Probe: EX3DV4 - SN3578; ConvF(10.02, 10.02, 10.02) @ 711 MHz; Calibrated: 2021/06/23
- Sensor-Surface: 1.4mm (Mechanical Surface Detection)
- Electronics: DAE4 Sn915; Calibrated: 2021/06/02
- Phantom: ELI Phantom\_1043; Type: QD OVA 002 Ax;
- Measurement SW: DASY52, Version 52.10 (4); SEMCAD X Version 14.6.14 (7501)

**Area Scan (71x261x1):** Interpolated grid: dx=1.500 mm, dy=1.500 mm

Maximum value of SAR (interpolated) = 0.872 W/kg

**Zoom Scan (5x5x7)/Cube 0:** Measurement grid: dx=8mm, dy=8mm, dz=5mm

Reference Value = 32.55 V/m; Power Drift = 0.03 dB

Peak SAR (extrapolated) = 1.04 W/kg

**SAR(1 g) = 0.559 W/kg; SAR(10 g) = 0.315 W/kg** (SAR corrected for target medium)

Smallest distance from peaks to all points 3 dB below = 11.2 mm

Ratio of SAR at M2 to SAR at M1 = 57.3%

Maximum value of SAR (measured) = 0.880 W/kg

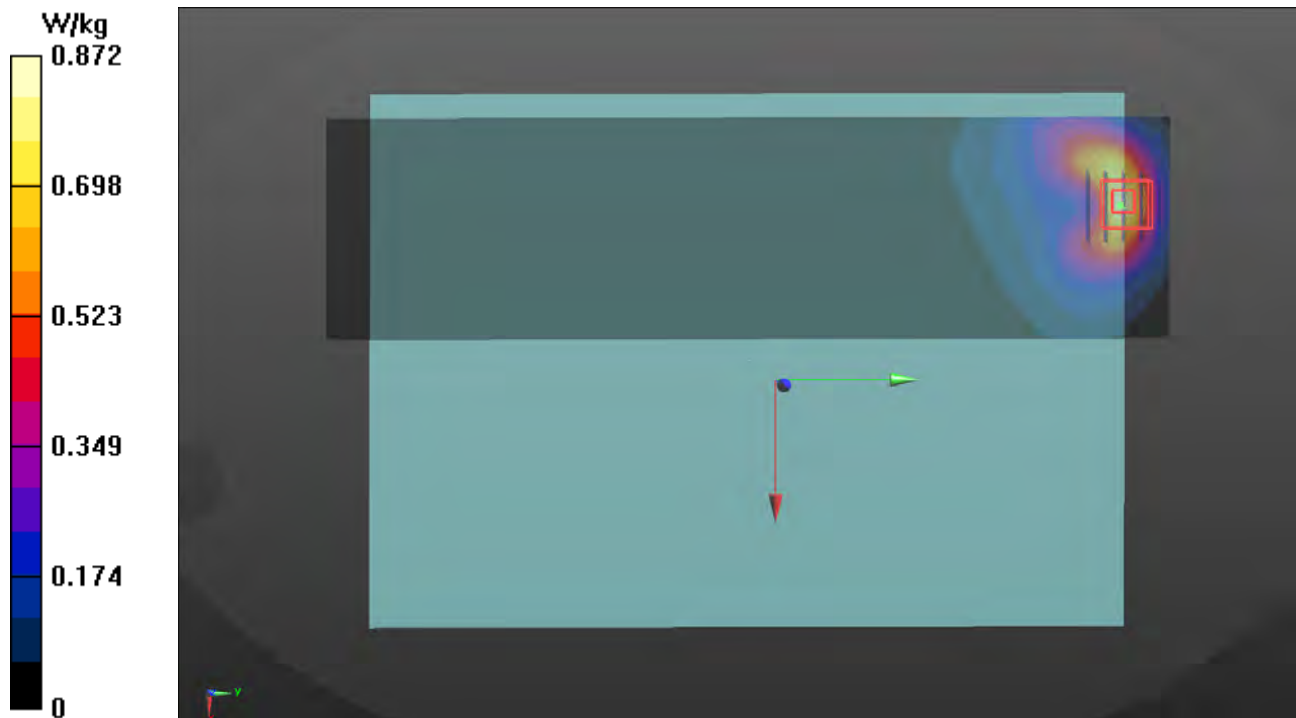

## Plots of Measurement

Test Laboratory: Bureau Veritas ADT SAR/HAC Testing Lab

Date: 2022/03/28

**P09 LTE13\_QPSK10M\_Bottom for Laptop\_0mm\_Ch23230\_1RB\_OS0\_Ant 0\_Power Reduction\_w**

**DUT: BFLF-WTW-P22030373**

Communication System: UID 10175 - CAG, LTE-FDD (SC-FDMA, 1 RB, 10 MHz, QPSK); Frequency: 782 MHz; Duty Cycle: 1:3.74

Medium: H06T09N1\_0328 Medium parameters used:  $f = 782$  MHz;  $\sigma = 0.913$  S/m;  $\epsilon_r = 41.476$ ;  $\rho = 1000$  kg/m<sup>3</sup>

Ambient Temperature : 23.8 °C ; Liquid Temperature : 23.4 °C

DASY5 Configuration:

- Probe: EX3DV4 - SN3578; ConvF(10.02, 10.02, 10.02) @ 782 MHz; Calibrated: 2021/06/23
- Sensor-Surface: 1.4mm (Mechanical Surface Detection)
- Electronics: DAE4 Sn915; Calibrated: 2021/06/02
- Phantom: ELI Phantom\_1043; Type: QD OVA 002 Ax;
- Measurement SW: DASY52, Version 52.10 (4); SEMCAD X Version 14.6.14 (7501)

**Area Scan (71x261x1):** Interpolated grid: dx=1.500 mm, dy=1.500 mm

Maximum value of SAR (interpolated) = 0.703 W/kg

**Zoom Scan (5x5x7)/Cube 0:** Measurement grid: dx=8mm, dy=8mm, dz=5mm

Reference Value = 28.12 V/m; Power Drift = 0.07 dB

Peak SAR (extrapolated) = 0.901 W/kg

**SAR(1 g) = 0.520 W/kg; SAR(10 g) = 0.313 W/kg** (SAR corrected for target medium)

Smallest distance from peaks to all points 3 dB below = 12.8 mm

Ratio of SAR at M2 to SAR at M1 = 60.2%

Maximum value of SAR (measured) = 0.764 W/kg

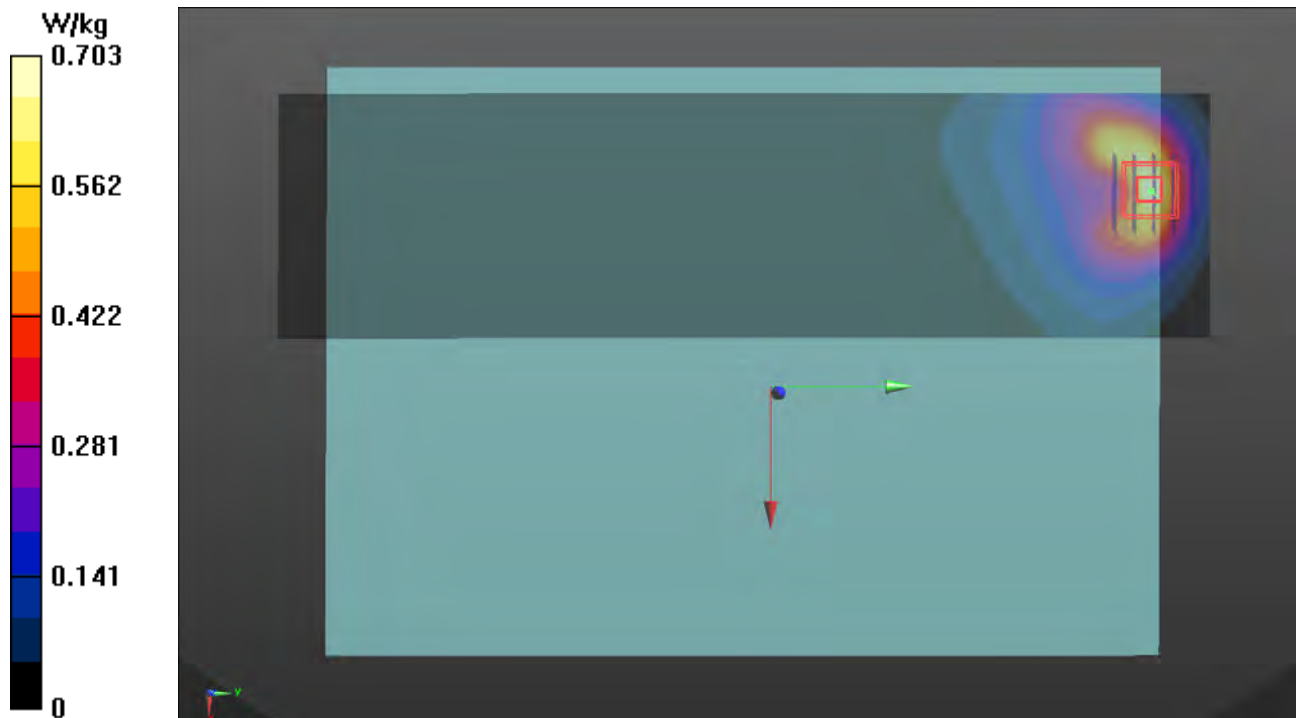

## Plots of Measurement

Test Laboratory: Bureau Veritas ADT SAR/HAC Testing Lab

Date: 2022/03/28

**P10 LTE 14\_QPSK10M\_Bottom for Laptop\_0mm\_Ch23330\_1RB\_OS0\_Ant 0\_Power Reduction\_w**

**DUT: BFLF-WTW-P22030373**

Communication System: UID 10175 - CAG, LTE-FDD (SC-FDMA, 1 RB, 10 MHz, QPSK); Frequency: 793 MHz; Duty Cycle: 1:3.74

Medium: H06T09N1\_0328 Medium parameters used:  $f = 793$  MHz;  $\sigma = 0.917$  S/m;  $\epsilon_r = 41.441$ ;  $\rho = 1000$  kg/m<sup>3</sup>

Ambient Temperature : 23.8 °C ; Liquid Temperature : 23.4 °C

DASY5 Configuration:

- Probe: EX3DV4 - SN3578; ConvF(10.02, 10.02, 10.02) @ 793 MHz; Calibrated: 2021/06/23
- Sensor-Surface: 1.4mm (Mechanical Surface Detection)
- Electronics: DAE4 Sn915; Calibrated: 2021/06/02
- Phantom: ELI Phantom\_1043; Type: QD OVA 002 Ax;
- Measurement SW: DASY52, Version 52.10 (4); SEMCAD X Version 14.6.14 (7501)

**Area Scan (71x261x1):** Interpolated grid: dx=1.500 mm, dy=1.500 mm

Maximum value of SAR (interpolated) = 0.933 W/kg

**Zoom Scan (5x5x7)/Cube 0:** Measurement grid: dx=8mm, dy=8mm, dz=5mm

Reference Value = 32.50 V/m; Power Drift = 0.04 dB

Peak SAR (extrapolated) = 1.09 W/kg

**SAR(1 g) = 0.625 W/kg; SAR(10 g) = 0.373 W/kg** (SAR corrected for target medium)

Smallest distance from peaks to all points 3 dB below = 12.8 mm

Ratio of SAR at M2 to SAR at M1 = 58.4%

Maximum value of SAR (measured) = 0.938 W/kg

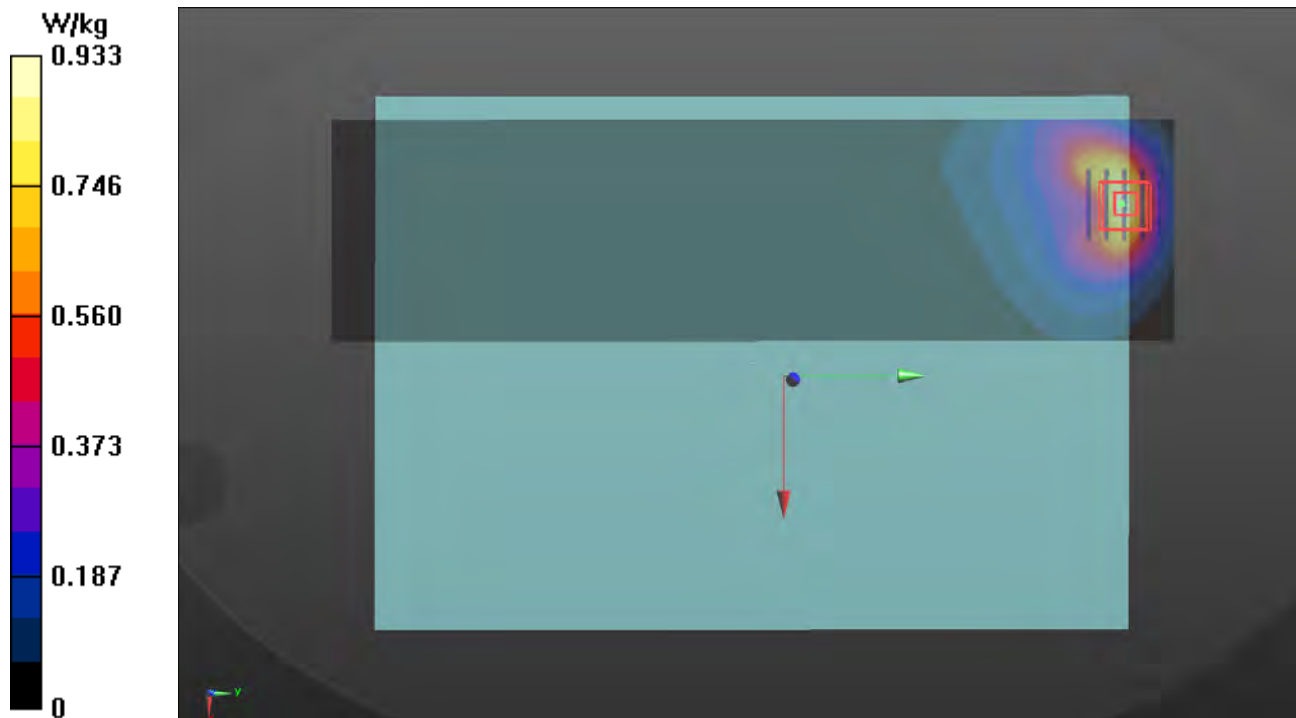

## Plots of Measurement

Test Laboratory: Bureau Veritas ADT SAR/HAC Testing Lab

Date: 2022/03/27

**P11 LTE 17\_QPSK10M\_Bottom for Laptop\_0mm\_Ch23790\_1RB\_OS0\_Ant 0\_Power Reduction\_w**

**DUT: BFLF-WTW-P22030373**

Communication System: UID 10175 - CAG, LTE-FDD (SC-FDMA, 1 RB, 10 MHz, QPSK); Frequency: 710 MHz; Duty Cycle: 1:3.74

Medium: H06T09N1\_0327 Medium parameters used:  $f = 710$  MHz;  $\sigma = 0.902$  S/m;  $\epsilon_r = 40.967$ ;  $\rho = 1000$  kg/m<sup>3</sup>

Ambient Temperature : 23.7 °C ; Liquid Temperature : 23.5 °C

DASY5 Configuration:

- Probe: EX3DV4 - SN3578; ConvF(10.02, 10.02, 10.02) @ 710 MHz; Calibrated: 2021/06/23
- Sensor-Surface: 1.4mm (Mechanical Surface Detection)
- Electronics: DAE4 Sn915; Calibrated: 2021/06/02
- Phantom: ELI Phantom\_1043; Type: QD OVA 002 Ax;
- Measurement SW: DASY52, Version 52.10 (4); SEMCAD X Version 14.6.14 (7501)

**Area Scan (71x261x1):** Interpolated grid: dx=1.500 mm, dy=1.500 mm

Maximum value of SAR (interpolated) = 0.867 W/kg

**Zoom Scan (5x5x7)/Cube 0:** Measurement grid: dx=8mm, dy=8mm, dz=5mm

Reference Value = 32.13 V/m; Power Drift = 0.05 dB

Peak SAR (extrapolated) = 1.06 W/kg

**SAR(1 g) = 0.588 W/kg; SAR(10 g) = 0.344 W/kg** (SAR corrected for target medium)

Smallest distance from peaks to all points 3 dB below = 11.2 mm

Ratio of SAR at M2 to SAR at M1 = 57.4%

Maximum value of SAR (measured) = 0.897 W/kg

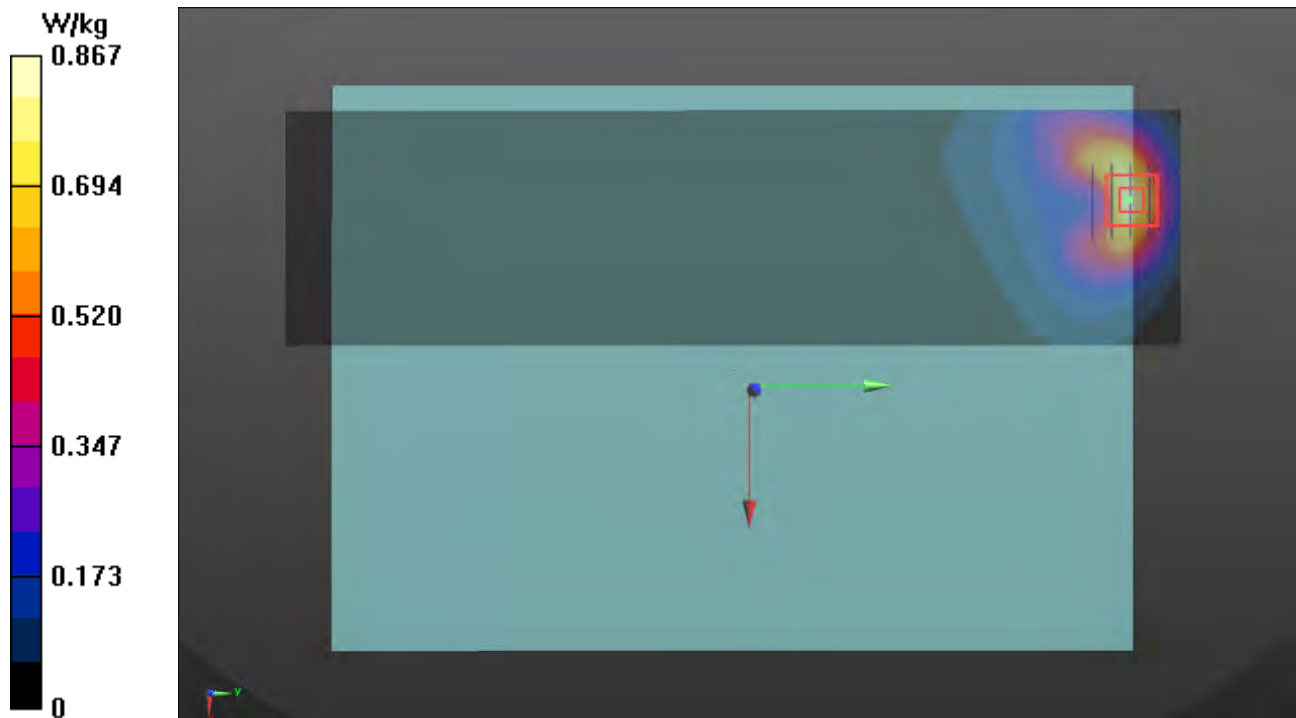

## Plots of Measurement

Test Laboratory: Bureau Veritas ADT SAR/HAC Testing Lab

Date: 2022/3/24

### P12 LTE 25\_QPSK20M\_Bottom For Laptop\_0mm\_Ch26590\_1RB\_OS0\_Ant 0\_Power Reduction\_w

DUT: BFLF-WTW-P22030373

Communication System: UID 10169 - CAE, LTE-FDD (SC-FDMA, 1 RB, 20 MHz, QPSK); Frequency: 1905 MHz; Duty Cycle: 1:3.74

Medium: H16T20N1\_0324 Medium parameters used:  $f = 1905$  MHz;  $\sigma = 1.465$  S/m;  $\epsilon_r = 38.788$ ;  $\rho = 1000$  kg/m<sup>3</sup>

Ambient Temperature : 23.7 °C ; Liquid Temperature : 23.3 °C

DASY5 Configuration:

- Probe: EX3DV4 - SN3578; ConvF(7.82, 7.82, 7.82) @ 1905 MHz; Calibrated: 2021/6/23
- Sensor-Surface: 1.4mm (Mechanical Surface Detection)
- Electronics: DAE4 Sn915; Calibrated: 2021/6/2
- Phantom: ELI Phantom\_1204; Type: QD OVA 002 Ax;
- Measurement SW: DASY52, Version 52.10 (4); SEMCAD X Version 14.6.14 (7501)

**Area Scan (71x261x1):** Interpolated grid: dx=1.500 mm, dy=1.500 mm

Maximum value of SAR (interpolated) = 0.667 W/kg

**Zoom Scan (5x5x7)/Cube 0:** Measurement grid: dx=8mm, dy=8mm, dz=5mm

Reference Value = 19.15 V/m; Power Drift = -0.09 dB

Peak SAR (extrapolated) = 0.973 W/kg

**SAR(1 g) = 0.476 W/kg; SAR(10 g) = 0.251 W/kg** (SAR corrected for target medium)

Smallest distance from peaks to all points 3 dB below = 11.5 mm

Ratio of SAR at M2 to SAR at M1 = 51.1%

Maximum value of SAR (measured) = 0.783 W/kg

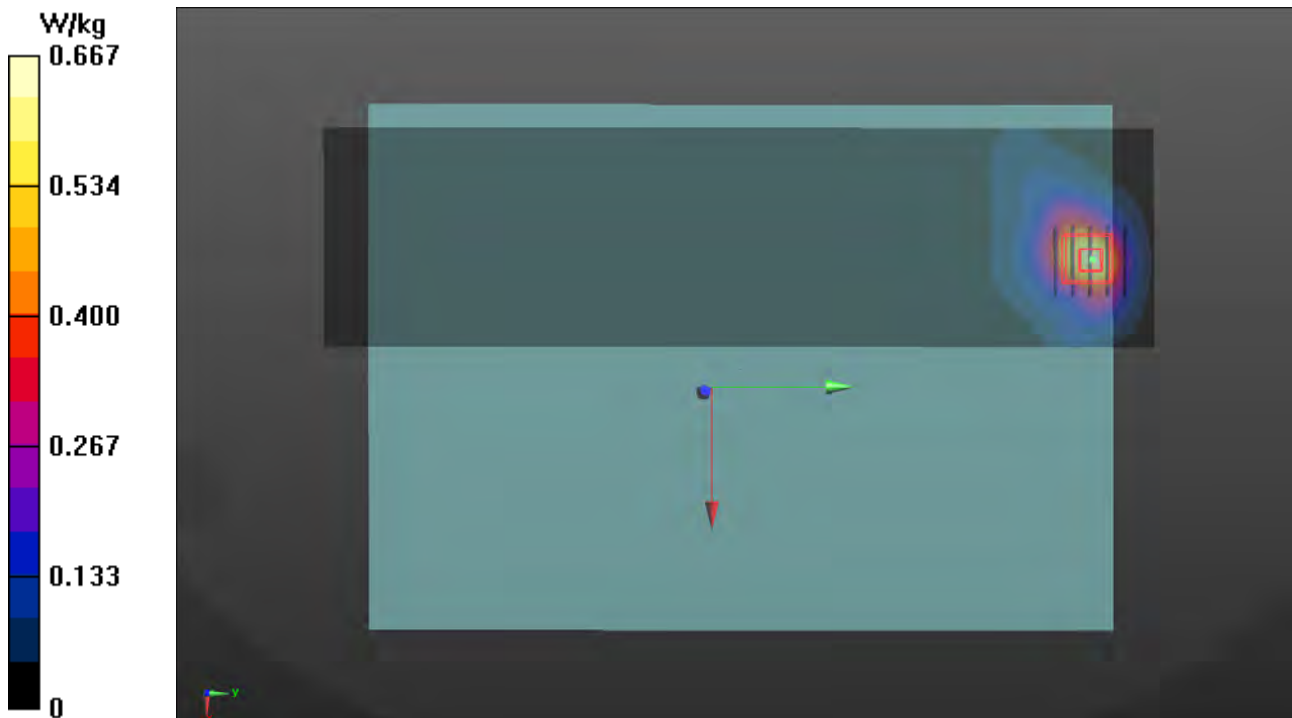

## Plots of Measurement

Test Laboratory: Bureau Veritas ADT SAR/HAC Testing Lab

Date: 2022/3/25

### P13 LTE 26\_QPSK15M\_Bottom for Laptop\_0mm\_Ch26965\_1RB\_OS0\_Ant 0\_Power Reduction\_w

DUT: BFLF-WTW-P22030373

Communication System: UID 10181 - CAE, LTE-FDD (SC-FDMA, 1 RB, 15 MHz, QPSK); Frequency: 841.5 MHz; Duty Cycle: 1:3.74

Medium: H07T10N1\_0325 Medium parameters used (interpolated):  $f = 841.5$  MHz;  $\sigma = 0.936$  S/m;  $\epsilon_r = 40.344$ ;  $\rho = 1000$  kg/m<sup>3</sup>

Ambient Temperature : 23.6 °C ; Liquid Temperature : 23.4 °C

DASY5 Configuration:

- Probe: EX3DV4 - SN3578; ConvF(9.54, 9.54, 9.54) @ 841.5 MHz; Calibrated: 2021/6/23
- Sensor-Surface: 1.4mm (Mechanical Surface Detection)
- Electronics: DAE4 Sn915; Calibrated: 2021/6/2
- Phantom: ELI Phantom\_1204; Type: QD OVA 002 Ax;
- Measurement SW: DASY52, Version 52.10 (4); SEMCAD X Version 14.6.14 (7501)

**Area Scan (71x261x1):** Interpolated grid: dx=1.500 mm, dy=1.500 mm  
Maximum value of SAR (interpolated) = 0.711 W/kg

**Zoom Scan (5x5x7)/Cube 0:** Measurement grid: dx=8mm, dy=8mm, dz=5mm

Reference Value = 28.32 V/m; Power Drift = 0.01 dB

Peak SAR (extrapolated) = 0.893 W/kg

**SAR(1 g) = 0.500 W/kg; SAR(10 g) = 0.304 W/kg** (SAR corrected for target medium)

Smallest distance from peaks to all points 3 dB below = 16 mm

Ratio of SAR at M2 to SAR at M1 = 58.1%

Maximum value of SAR (measured) = 0.752 W/kg

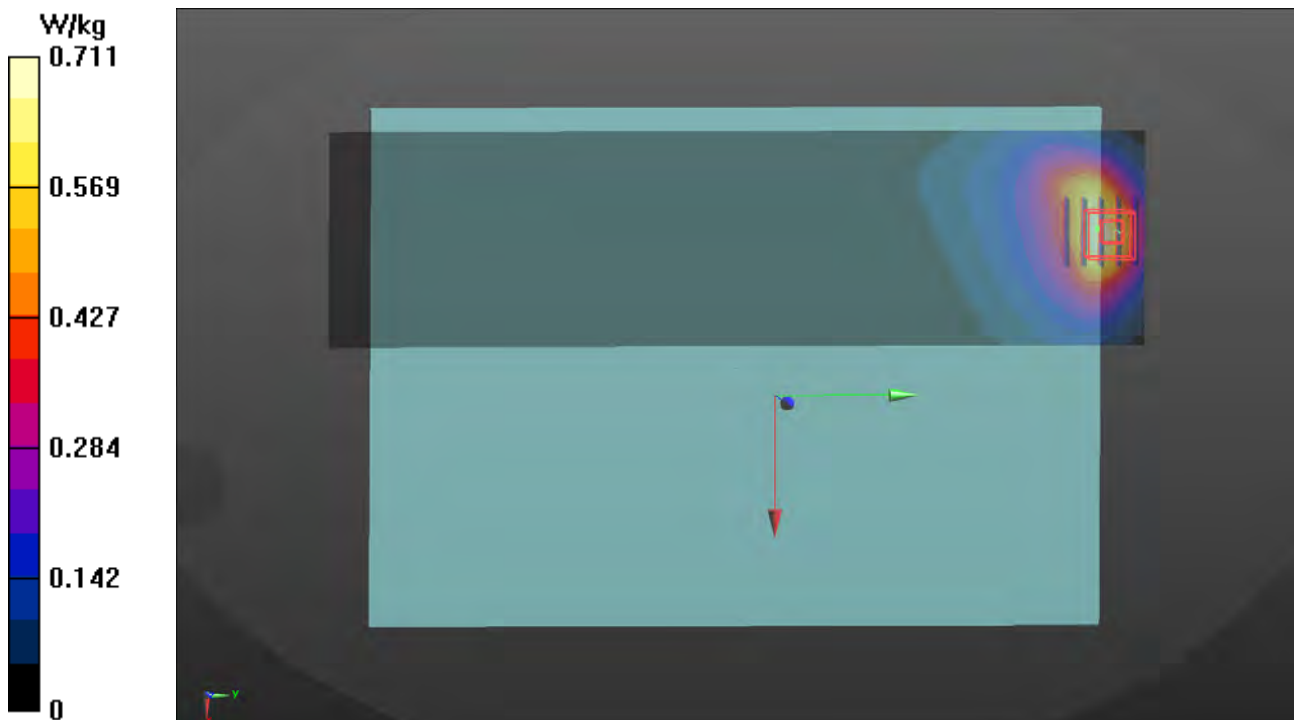



## Plots of Measurement

Test Laboratory: Bureau Veritas ADT SAR/HAC Testing Lab

Date: 2022/04/09

**P14 LTE 30\_QPSK10M\_Bottom for Laptop\_0mm\_Ch27710\_1RB\_OS0\_Ant 0\_Power Reduction\_w**

**DUT: BFLF-WTW-P22030373**

Communication System: UID 10175 - CAG, LTE-FDD (SC-FDMA, 1 RB, 10 MHz, QPSK); Frequency: 2310 MHz; Duty Cycle: 1:3.74

Medium: H19T27N1\_0409 Medium parameters used:  $f = 2310$  MHz;  $\sigma = 1.724$  S/m;  $\epsilon_r = 38.447$ ;  $\rho = 1000$  kg/m<sup>3</sup>

Ambient Temperature : 23.6 °C ; Liquid Temperature : 23.5 °C

DASY5 Configuration:

- Probe: EX3DV4 - SN3578; ConvF(7.58, 7.58, 7.58) @ 2310 MHz; Calibrated: 2021/06/23
- Sensor-Surface: 1.4mm (Mechanical Surface Detection)
- Electronics: DAE4 Sn915; Calibrated: 2021/06/02
- Phantom: ELI Phantom\_1043; Type: QD OVA 002 Ax;
- Measurement SW: DASY52, Version 52.10 (4); SEMCAD X Version 14.6.14 (7501)

**Area Scan (91x321x1):** Interpolated grid: dx=1.200 mm, dy=1.200 mm

Maximum value of SAR (interpolated) = 0.889 W/kg

**Zoom Scan (7x7x7)/Cube 0:** Measurement grid: dx=5mm, dy=5mm, dz=5mm

Reference Value = 22.88 V/m; Power Drift = -0.07 dB

Peak SAR (extrapolated) = 1.16 W/kg

**SAR(1 g) = 0.534 W/kg; SAR(10 g) = 0.293 W/kg** (SAR corrected for target medium)

Smallest distance from peaks to all points 3 dB below = 15.6 mm

Ratio of SAR at M2 to SAR at M1 = 43.7%

Maximum value of SAR (measured) = 0.898 W/kg

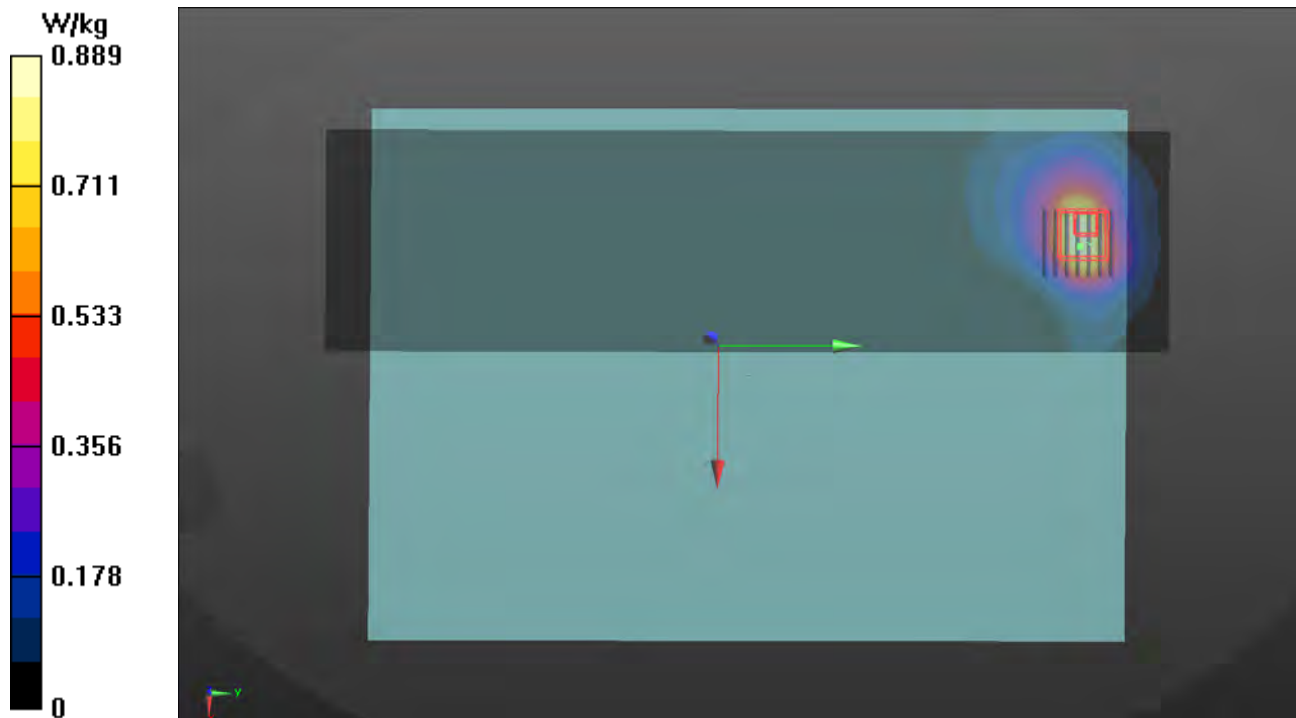

## Plots of Measurement

Test Laboratory: Bureau Veritas ADT SAR/HAC Testing Lab

Date: 2022/03/29

**P15 LTE 38\_QPSK20M\_Bottom for Laptop\_0mm\_Ch38150\_1RB\_OS0\_Ant 0\_Power Reduction\_w**

**DUT: BFLF-WTW-P22030373**

Communication System: UID 10172 - CAG, LTE-TDD (SC-FDMA, 1 RB, 20 MHz, QPSK); Frequency: 2610 MHz; Duty Cycle: 1:8.33

Medium: H19T27N3\_0329 Medium parameters used:  $f = 2610$  MHz;  $\sigma = 1.924$  S/m;  $\epsilon_r = 37.8$ ;  $\rho = 1000$  kg/m<sup>3</sup>

Ambient Temperature : 23.4 °C ; Liquid Temperature : 23.3 °C

DASY5 Configuration:

- Probe: EX3DV4 - SN3578; ConvF(7.22, 7.22, 7.22) @ 2610 MHz; Calibrated: 2021/06/23
- Sensor-Surface: 1.4mm (Mechanical Surface Detection)
- Electronics: DAE4 Sn915; Calibrated: 2021/06/02
- Phantom: ELI Phantom\_1043; Type: QD OVA 002 Ax;
- Measurement SW: DASY52, Version 52.10 (4); SEMCAD X Version 14.6.14 (7501)

**Area Scan (91x321x1):** Interpolated grid: dx=1.200 mm, dy=1.200 mm

Maximum value of SAR (interpolated) = 0.874 W/kg

**Zoom Scan (7x7x7)/Cube 0:** Measurement grid: dx=5mm, dy=5mm, dz=5mm

Reference Value = 21.20 V/m; Power Drift = 0.04 dB

Peak SAR (extrapolated) = 1.19 W/kg

**SAR(1 g) = 0.512 W/kg; SAR(10 g) = 0.274 W/kg** (SAR corrected for target medium)

Smallest distance from peaks to all points 3 dB below = 12 mm

Ratio of SAR at M2 to SAR at M1 = 44.7%

Maximum value of SAR (measured) = 0.896 W/kg

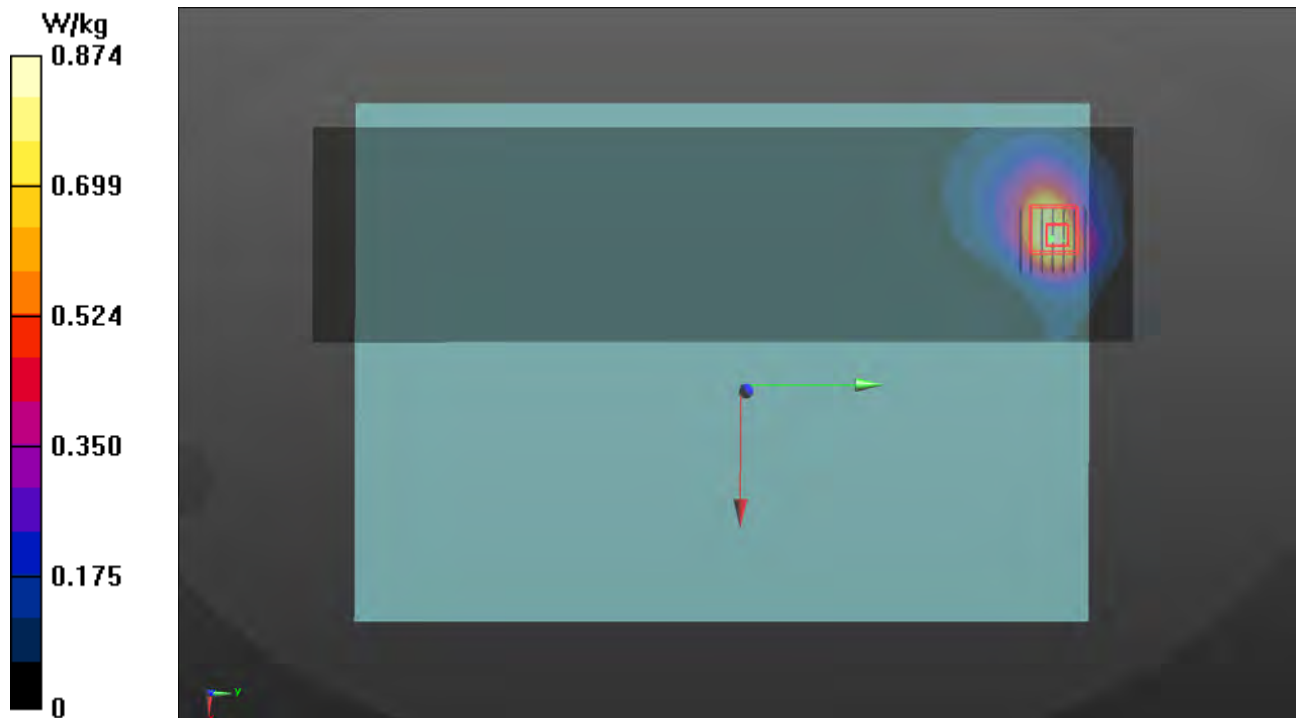

## Plots of Measurement

Test Laboratory: Bureau Veritas ADT SAR/HAC Testing Lab

Date: 2022/04/09

**P16 LTE 40\_QPSK20M\_Bottom for Laptop\_0mm\_Ch38750\_1RB\_OS0\_Ant 0\_Power Reduction\_w**

**DUT: BFLF-WTW-P22030373**

Communication System: UID 10172 - CAG, LTE-TDD (SC-FDMA, 1 RB, 20 MHz, QPSK); Frequency: 2310 MHz; Duty Cycle: 1:8.33

Medium: H19T27N1\_0409 Medium parameters used:  $f = 2310$  MHz;  $\sigma = 1.724$  S/m;  $\epsilon_r = 38.447$ ;  $\rho = 1000$  kg/m<sup>3</sup>

Ambient Temperature : 23.6 °C ; Liquid Temperature : 23.5 °C

DASY5 Configuration:

- Probe: EX3DV4 - SN3578; ConvF(7.58, 7.58, 7.58) @ 2310 MHz; Calibrated: 2021/06/23
- Sensor-Surface: 1.4mm (Mechanical Surface Detection)
- Electronics: DAE4 Sn915; Calibrated: 2021/06/02
- Phantom: ELI Phantom\_1043; Type: QD OVA 002 Ax;
- Measurement SW: DASY52, Version 52.10 (4); SEMCAD X Version 14.6.14 (7501)

**Area Scan (91x321x1):** Interpolated grid: dx=1.200 mm, dy=1.200 mm

Maximum value of SAR (interpolated) = 1.71 W/kg

**Zoom Scan (7x7x7)/Cube 0:** Measurement grid: dx=5mm, dy=5mm, dz=5mm

Reference Value = 30.34 V/m; Power Drift = -0.10 dB

Peak SAR (extrapolated) = 1.06 W/kg

**SAR(1 g) = 0.521 W/kg; SAR(10 g) = 0.293 W/kg** (SAR corrected for target medium)

Smallest distance from peaks to all points 3 dB below = 13.4 mm

Ratio of SAR at M2 to SAR at M1 = 49.4%

Maximum value of SAR (measured) = 0.833 W/kg

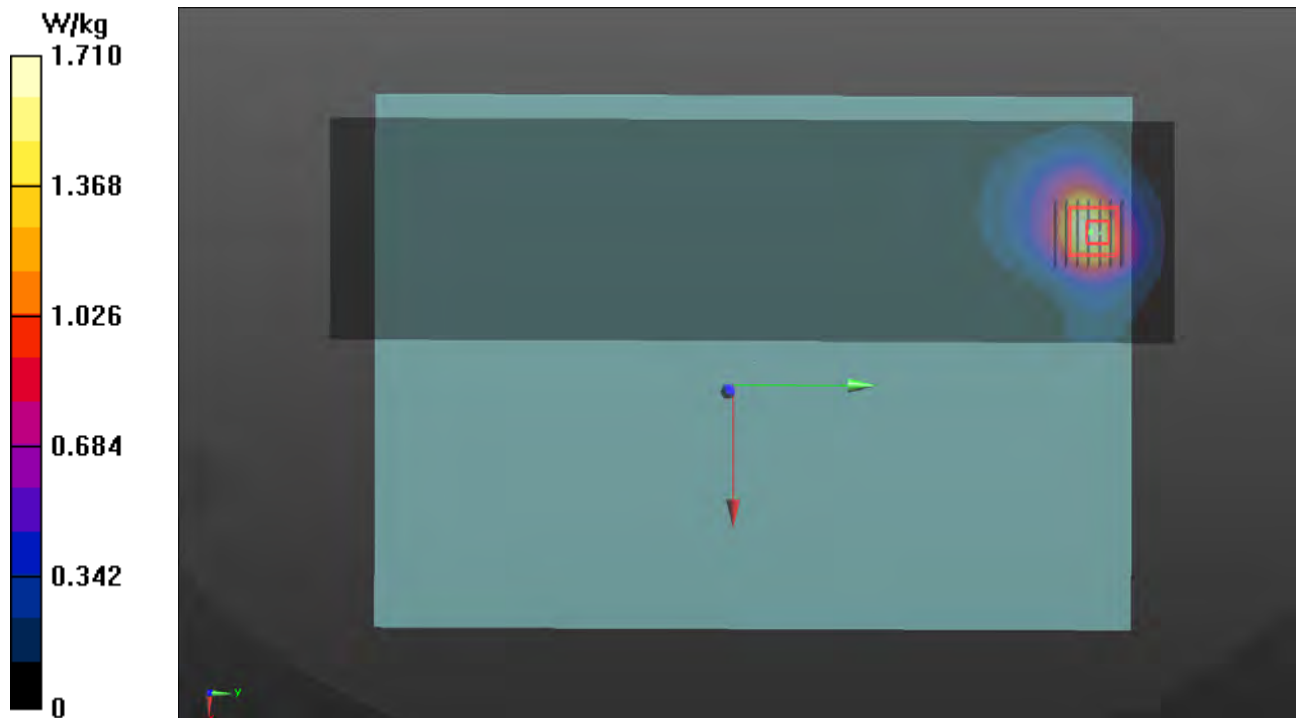

## Plots of Measurement

Test Laboratory: Bureau Veritas ADT SAR/HAC Testing Lab

Date: 2022/04/09

**P17 LTE 41\_QPSK20M\_Bottom for Laptop\_0mm\_Ch40620\_1RB\_OS0\_Ant 2\_Power Reduction\_w**

**DUT: BFLF-WTW-P22030373**

Communication System: UID 10172 - CAG, LTE-TDD (SC-FDMA, 1 RB, 20 MHz, QPSK); Frequency: 2593 MHz; Duty Cycle: 1:8.33

Medium: H19T27N1\_0409 Medium parameters used (interpolated):  $f = 2593$  MHz;  $\sigma = 2.019$  S/m;  $\epsilon_r = 37.5$ ;  $\rho = 1000$  kg/m<sup>3</sup>

Ambient Temperature : 23.6 °C ; Liquid Temperature : 23.5 °C

DASY5 Configuration:

- Probe: EX3DV4 - SN3578; ConvF(7.22, 7.22, 7.22) @ 2593 MHz; Calibrated: 2021/06/23
- Sensor-Surface: 1.4mm (Mechanical Surface Detection)
- Electronics: DAE4 Sn915; Calibrated: 2021/06/02
- Phantom: ELI Phantom\_1043; Type: QD OVA 002 Ax;
- Measurement SW: DASY52, Version 52.10 (4); SEMCAD X Version 14.6.14 (7501)

**Area Scan (91x321x1):** Interpolated grid: dx=1.200 mm, dy=1.200 mm.  
Maximum value of SAR (interpolated) = 0.485 W/kg

**Zoom Scan (7x7x7)/Cube 0:** Measurement grid: dx=5mm, dy=5mm, dz=5mm  
Reference Value = 13.82 V/m; Power Drift = -0.02 dB

Peak SAR (extrapolated) = 0.878 W/kg

**SAR(1 g) = 0.404 W/kg; SAR(10 g) = 0.190 W/kg** (SAR corrected for target medium)

Smallest distance from peaks to all points 3 dB below = 10.8 mm

Ratio of SAR at M2 to SAR at M1 = 48.3%

Maximum value of SAR (measured) = 0.697 W/kg

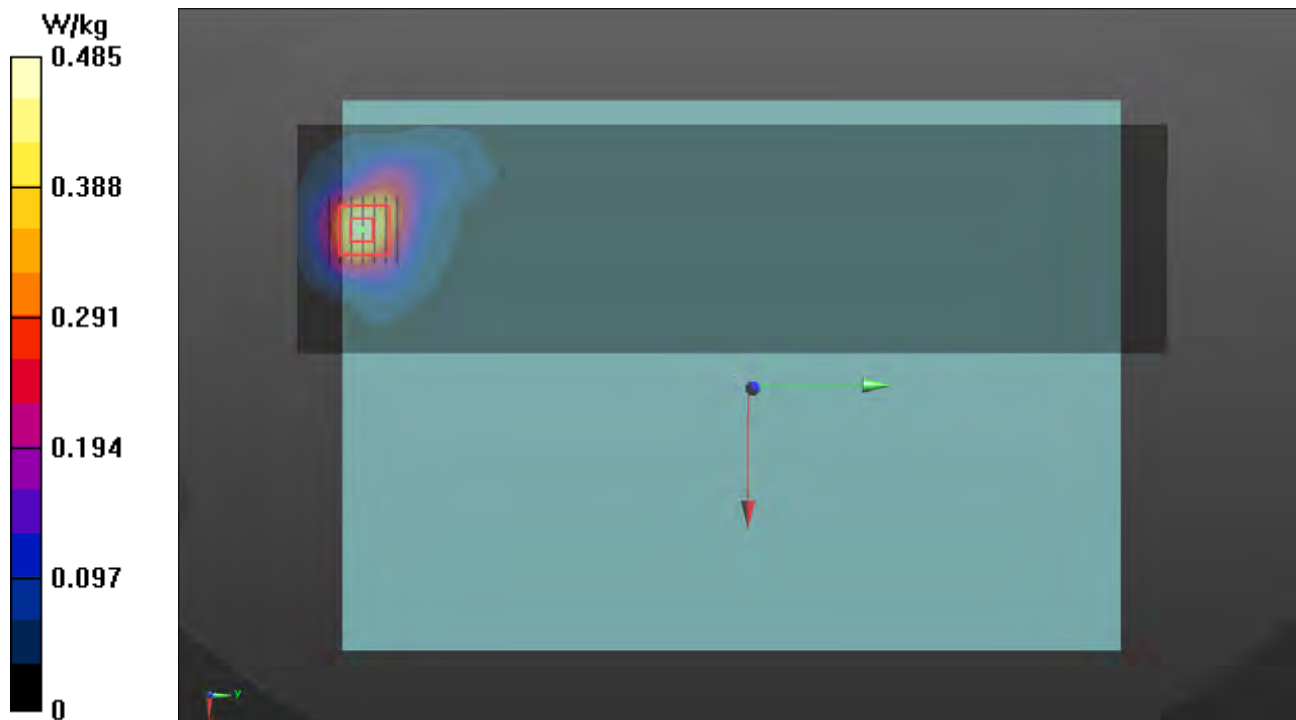

## Plots of Measurement

Test Laboratory: Bureau Veritas ADT SAR/HAC Testing Lab

Date: 2022/03/26

### P20 LTE 48\_QPSK20M\_Bottom for Laptop\_0mm\_Ch56640\_1RB\_OS0\_Ant 2\_Power Reduction\_w

DUT: BFLF-WTW-P22030373

Communication System: UID 10172 - CAG, LTE-TDD (SC-FDMA, 1 RB, 20 MHz, QPSK); Frequency: 3690 MHz; Duty Cycle: 1:8.33

Medium: H33T42N1\_0326 Medium parameters used:  $f = 3690$  MHz;  $\sigma = 3.129$  S/m;  $\epsilon_r = 37.224$ ;  $\rho = 1000$  kg/m<sup>3</sup>

Ambient Temperature : 23.4 °C ; Liquid Temperature : 23.3 °C

DASY5 Configuration:

- Probe: EX3DV4 - SN3578; ConvF(6.96, 6.96, 6.96) @ 3690 MHz; Calibrated: 2021/6/23
- Sensor-Surface: 1.4mm (Mechanical Surface Detection)
- Electronics: DAE4 Sn915; Calibrated: 2021/6/2
- Phantom: ELI Phantom\_1043; Type: QD OVA 002 Ax;
- Measurement SW: DASY52, Version 52.10 (4); SEMCAD X Version 14.6.14 (7501)

**Area Scan (91x321x1):** Interpolated grid: dx=1.200 mm, dy=1.200 mm

Maximum value of SAR (interpolated) = 0.517 W/kg

**Zoom Scan (7x7x7)/Cube 0:** Measurement grid: dx=5mm, dy=5mm, dz=2.5mm

Reference Value = 13.30 V/m; Power Drift = -0.11 dB

Peak SAR (extrapolated) = 0.885 W/kg

**SAR(1 g) = 0.315 W/kg; SAR(10 g) = 0.136 W/kg** (SAR corrected for target medium)

Smallest distance from peaks to all points 3 dB below = 9.8 mm

Ratio of SAR at M2 to SAR at M1 = 56.4%

Maximum value of SAR (measured) = 0.602 W/kg

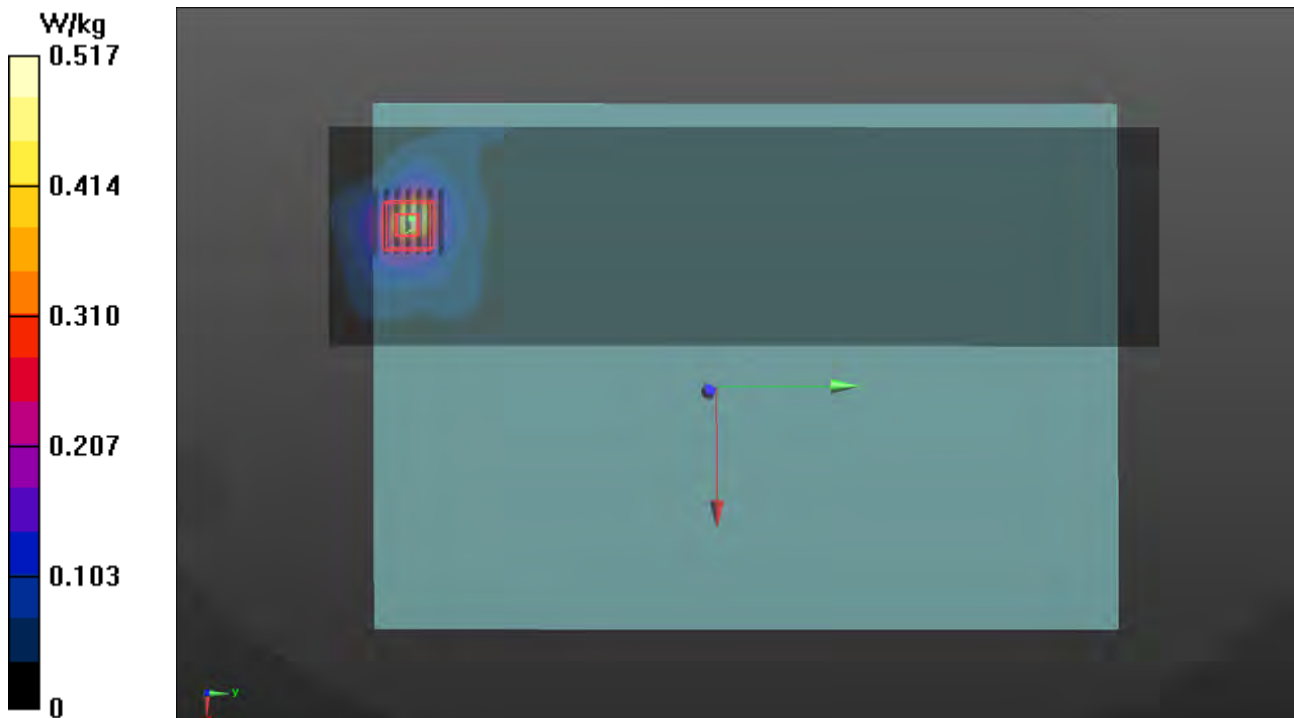

## Plots of Measurement

Test Laboratory: Bureau Veritas ADT SAR/HAC Testing Lab

Date: 2022/3/25

### P21 LTE66\_QPSK20M\_Bottom for Laptop\_0mm\_Ch132322\_1RB\_OS0\_Ant 0\_Power Reduction\_w

DUT: BFLF-WTW-P22030373

Communication System: UID 10169 - CAE, LTE-FDD (SC-FDMA, 1 RB, 20 MHz, QPSK); Frequency: 1745 MHz; Duty Cycle: 1:3.74

Medium: H16T20N1\_0325 Medium parameters used (interpolated):  $f = 1745$  MHz;  $\sigma = 1.316$  S/m;  $\epsilon_r = 40.279$ ;  $\rho = 1000$  kg/m<sup>3</sup>

Ambient Temperature : 23.6 °C ; Liquid Temperature : 23.4 °C

DASY5 Configuration:

- Probe: EX3DV4 - SN3578; ConvF(8.09, 8.09, 8.09) @ 1745 MHz; Calibrated: 2021/6/23
- Sensor-Surface: 1.4mm (Mechanical Surface Detection)
- Electronics: DAE4 Sn915; Calibrated: 2021/6/2
- Phantom: ELI Phantom\_1204; Type: QD OVA 002 Ax;
- Measurement SW: DASY52, Version 52.10 (4); SEMCAD X Version 14.6.14 (7501)

**Area Scan (71x261x1):** Interpolated grid: dx=1.500 mm, dy=1.500 mm  
Maximum value of SAR (interpolated) = 0.856 W/kg

**Zoom Scan (5x5x7)/Cube 0:** Measurement grid: dx=8mm, dy=8mm, dz=5mm

Reference Value = 24.32 V/m; Power Drift = -0.02 dB

Peak SAR (extrapolated) = 1.16 W/kg

**SAR(1 g) = 0.586 W/kg; SAR(10 g) = 0.344 W/kg** (SAR corrected for target medium)

Smallest distance from peaks to all points 3 dB below = 11.6 mm

Ratio of SAR at M2 to SAR at M1 = 54%

Maximum value of SAR (measured) = 0.952 W/kg

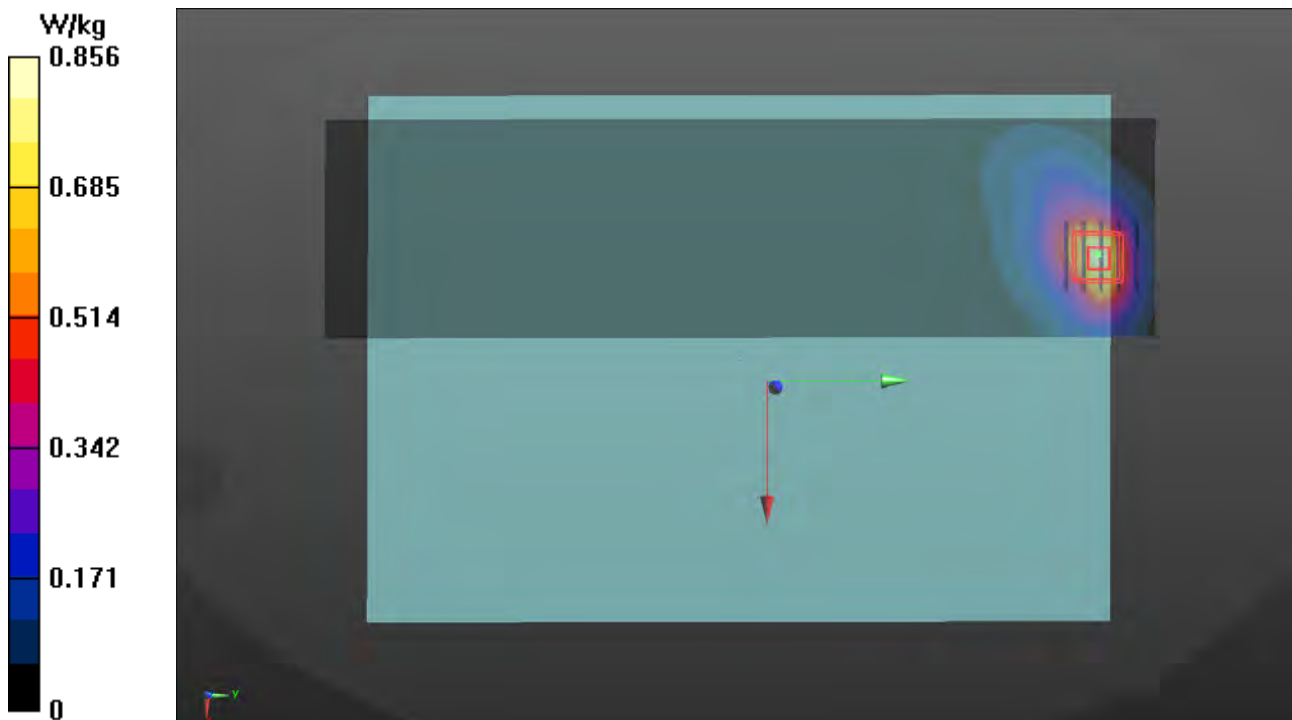

## Plots of Measurement

Test Laboratory: Bureau Veritas ADT SAR/HAC Testing Lab

Date: 2022/03/27

**P22 LTE71\_QPSK20M\_Bottom for Laptop\_0mm\_Ch133297\_1RB\_OS0\_Ant 0\_Power Reduction\_w**

**DUT: BFLF-WTW-P22030373**

Communication System: UID 10169 - CAE, LTE-FDD (SC-FDMA, 1 RB, 20 MHz, QPSK); Frequency: 680.5 MHz; Duty Cycle: 1:3.74

Medium: H06T09N1\_0327 Medium parameters used (interpolated):  $f = 680.5$  MHz;  $\sigma = 0.893$  S/m;  $\epsilon_r = 41.018$ ;  $\rho = 1000$  kg/m<sup>3</sup>

Ambient Temperature : 23.7 °C ; Liquid Temperature : 23.5 °C

DASY5 Configuration:

- Probe: EX3DV4 - SN3578; ConvF(10.02, 10.02, 10.02) @ 680.5 MHz; Calibrated: 2021/06/23
- Sensor-Surface: 1.4mm (Mechanical Surface Detection)
- Electronics: DAE4 Sn915; Calibrated: 2021/06/02
- Phantom: ELI Phantom\_1043; Type: QD OVA 002 Ax;
- Measurement SW: DASY52, Version 52.10 (4); SEMCAD X Version 14.6.14 (7501)

**Area Scan (71x261x1):** Interpolated grid: dx=1.500 mm, dy=1.500 mm  
Maximum value of SAR (interpolated) = 1.01 W/kg

**Zoom Scan (5x5x7)/Cube 0:** Measurement grid: dx=8mm, dy=8mm, dz=5mm

Reference Value = 35.40 V/m; Power Drift = 0.04 dB

Peak SAR (extrapolated) = 1.25 W/kg

**SAR(1 g) = 0.655 W/kg; SAR(10 g) = 0.405 W/kg** (SAR corrected for target medium)

Smallest distance from peaks to all points 3 dB below = 11.2 mm

Ratio of SAR at M2 to SAR at M1 = 56.8%

Maximum value of SAR (measured) = 1.06 W/kg

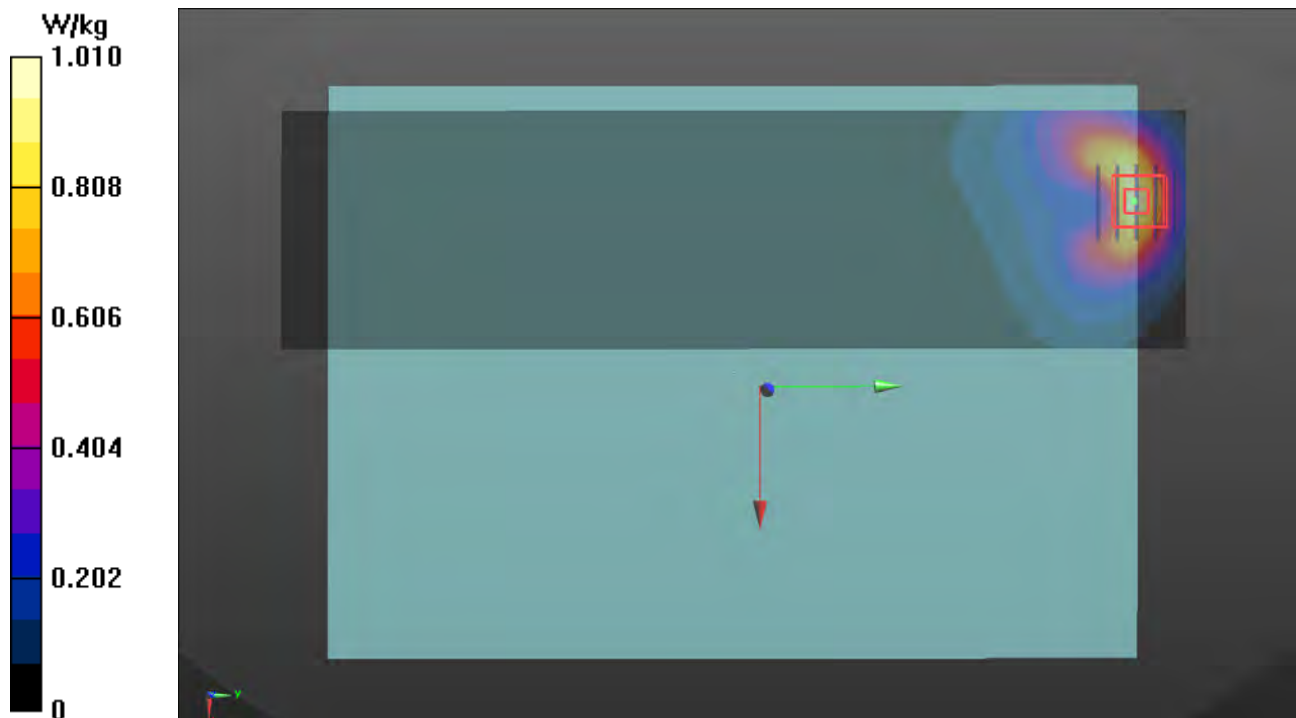

## Plots of Measurement

Test Laboratory: Bureau Veritas ADT SAR/HAC Testing Lab

Date: 2022/3/24

**P23 5GNR-n2\_DFT-S QPSK20M\_Bottom For Laptop\_0mm\_Ch376000\_1RB\_OS1\_Ant 0\_Power Reduction\_w**

DUT: BFLF-WTW-P22030373

Communication System: UID 10931 - AAB, 5G NR (DFT-s-OFDM, 1 RB, 20 MHz, QPSK, 15 kHz); Frequency: 1880 MHz; Duty Cycle: 1:3.56

Medium: H16T20N1\_0324 Medium parameters used:  $f = 1880$  MHz;  $\sigma = 1.45$  S/m;  $\epsilon_r = 38.777$ ;  $\rho = 1000$  kg/m<sup>3</sup>

Ambient Temperature : 23.7 °C ; Liquid Temperature : 23.3 °C

DASY5 Configuration:

- Probe: EX3DV4 - SN3578; ConvF(7.82, 7.82, 7.82) @ 1880 MHz; Calibrated: 2021/6/23
- Sensor-Surface: 1.4mm (Mechanical Surface Detection)
- Electronics: DAE4 Sn915; Calibrated: 2021/6/2
- Phantom: ELI Phantom\_1204; Type: QD OVA 002 Ax;
- Measurement SW: DASY52, Version 52.10 (4); SEMCAD X Version 14.6.14 (7501)

**Area Scan (71x261x1):** Interpolated grid: dx=1.500 mm, dy=1.500 mm

Maximum value of SAR (interpolated) = 0.765 W/kg

**Zoom Scan (5x5x7)/Cube 0:** Measurement grid: dx=8mm, dy=8mm, dz=5mm

Reference Value = 21.00 V/m; Power Drift = -0.07 dB

Peak SAR (extrapolated) = 1.15 W/kg

**SAR(1 g) = 0.553 W/kg; SAR(10 g) = 0.297 W/kg** (SAR corrected for target medium)

Smallest distance from peaks to all points 3 dB below = 11.3 mm

Ratio of SAR at M2 to SAR at M1 = 51%

Maximum value of SAR (measured) = 0.919 W/kg

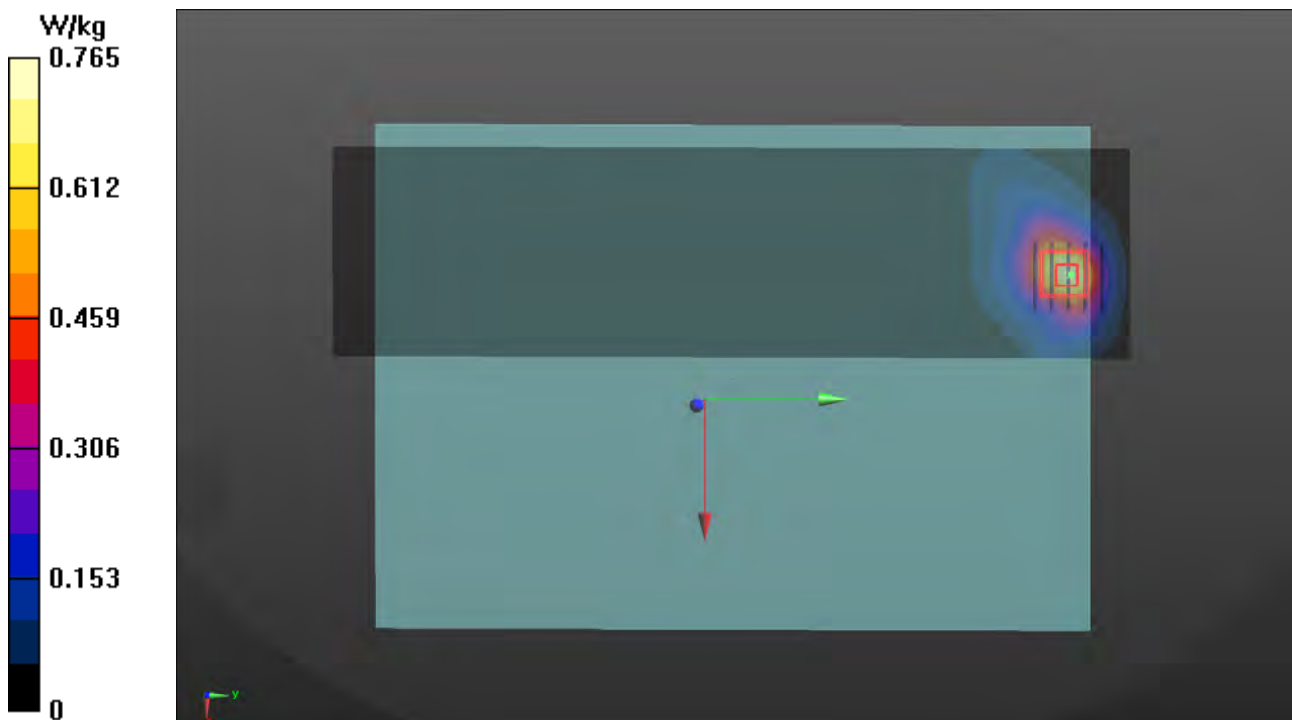



## Plots of Measurement

Test Laboratory: Bureau Veritas ADT SAR/HAC Testing Lab

Date: 2022/03/25

**P24 5GNR-n5\_DFT-S QPSK20M\_Bottom for Laptop\_0mm\_Ch167300\_1RB\_OS1\_Ant 0\_Power Reduction\_w**

**DUT: BFLF-WTW-P22030373**

Communication System: UID 10931 - AAC, 5G NR (DFT-s-OFDM, 1 RB, 20 MHz, QPSK, 15 kHz); Frequency: 836.5 MHz; Duty Cycle: 1:3.56

Medium: H07T10N1\_0325 Medium parameters used (interpolated):  $f = 836.5$  MHz;  $\sigma = 0.934$  S/m;  $\epsilon_r = 40.368$ ;  $\rho = 1000$  kg/m<sup>3</sup>

Ambient Temperature : 23.6 °C ; Liquid Temperature : 23.4 °C

DASY5 Configuration:

- Probe: EX3DV4 - SN3578; ConvF(9.54, 9.54, 9.54) @ 836.5 MHz; Calibrated: 2021/06/23
- Sensor-Surface: 1.4mm (Mechanical Surface Detection)
- Electronics: DAE4 Sn915; Calibrated: 2021/06/02
- Phantom: ELI Phantom\_1204; Type: QD OVA 002 Ax;
- Measurement SW: DASY52, Version 52.10 (4); SEMCAD X Version 14.6.14 (7501)

**Area Scan (71x261x1):** Interpolated grid: dx=1.500 mm, dy=1.500 mm  
Maximum value of SAR (interpolated) = 0.841 W/kg

**Zoom Scan (5x5x7)/Cube 0:** Measurement grid: dx=8mm, dy=8mm, dz=5mm

Reference Value = 28.50 V/m; Power Drift = -0.04 dB

Peak SAR (extrapolated) = 0.872 W/kg

**SAR(1 g) = 0.502 W/kg; SAR(10 g) = 0.309 W/kg** (SAR corrected for target medium)

Smallest distance from peaks to all points 3 dB below = 12.2 mm

Ratio of SAR at M2 to SAR at M1 = 58.6%

Maximum value of SAR (measured) = 0.750 W/kg

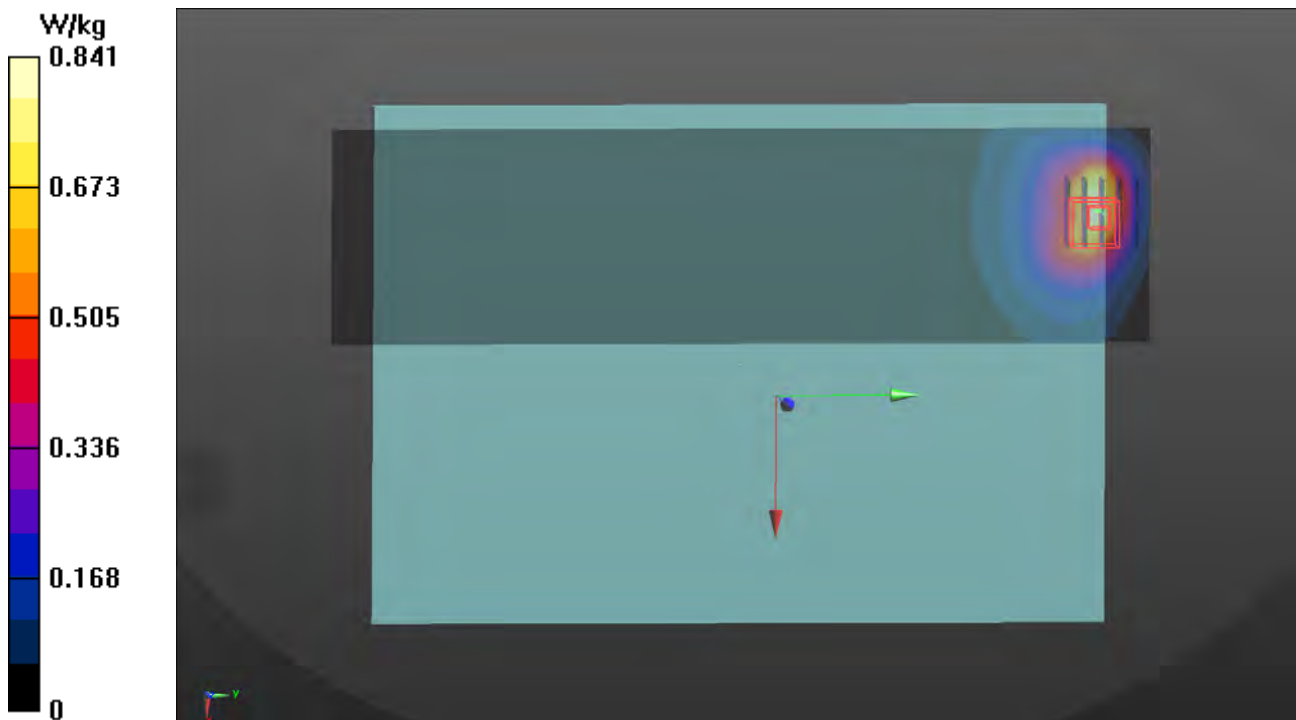

## Plots of Measurement

Test Laboratory: Bureau Veritas ADT SAR/HAC Testing Lab

Date: 2022/03/29

**P25 5GNR-n7\_DFT-S QPSK20M\_Bottom for Laptop\_0mm\_Ch502000\_1RB\_OS1\_Ant 0\_Power Reduction\_w**

**DUT: BFLF-WTW-P22030373**

Communication System: UID 10931 - AAB, 5G NR (DFT-s-OFDM, 1 RB, 20 MHz, QPSK, 15 kHz); Frequency: 2510 MHz; Duty Cycle: 1:3.56

Medium: H19T27N3\_0329 Medium parameters used:  $f = 2510$  MHz;  $\sigma = 1.854$  S/m;  $\epsilon_r = 37.973$ ;  $\rho = 1000$  kg/m<sup>3</sup>

Ambient Temperature : 23.4 °C ; Liquid Temperature : 23.3 °C

DASY5 Configuration:

- Probe: EX3DV4 - SN3578; ConvF(7.22, 7.22, 7.22) @ 2510 MHz; Calibrated: 2021/06/23
- Sensor-Surface: 1.4mm (Mechanical Surface Detection)
- Electronics: DAE4 Sn915; Calibrated: 2021/06/02
- Phantom: ELI Phantom\_1043; Type: QD OVA 002 Ax;
- Measurement SW: DASY52, Version 52.10 (4); SEMCAD X Version 14.6.14 (7501)

**Area Scan (91x321x1):** Interpolated grid: dx=1.200 mm, dy=1.200 mm

Maximum value of SAR (interpolated) = 0.545 W/kg

**Zoom Scan (7x7x7)/Cube 0:** Measurement grid: dx=5mm, dy=5mm, dz=5mm

Reference Value = 17.05 V/m; Power Drift = -0.06 dB

Peak SAR (extrapolated) = 0.708 W/kg

**SAR(1 g) = 0.352 W/kg; SAR(10 g) = 0.191 W/kg** (SAR corrected for target medium)

Smallest distance from peaks to all points 3 dB below = 13 mm

Ratio of SAR at M2 to SAR at M1 = 49.1%

Maximum value of SAR (measured) = 0.565 W/kg

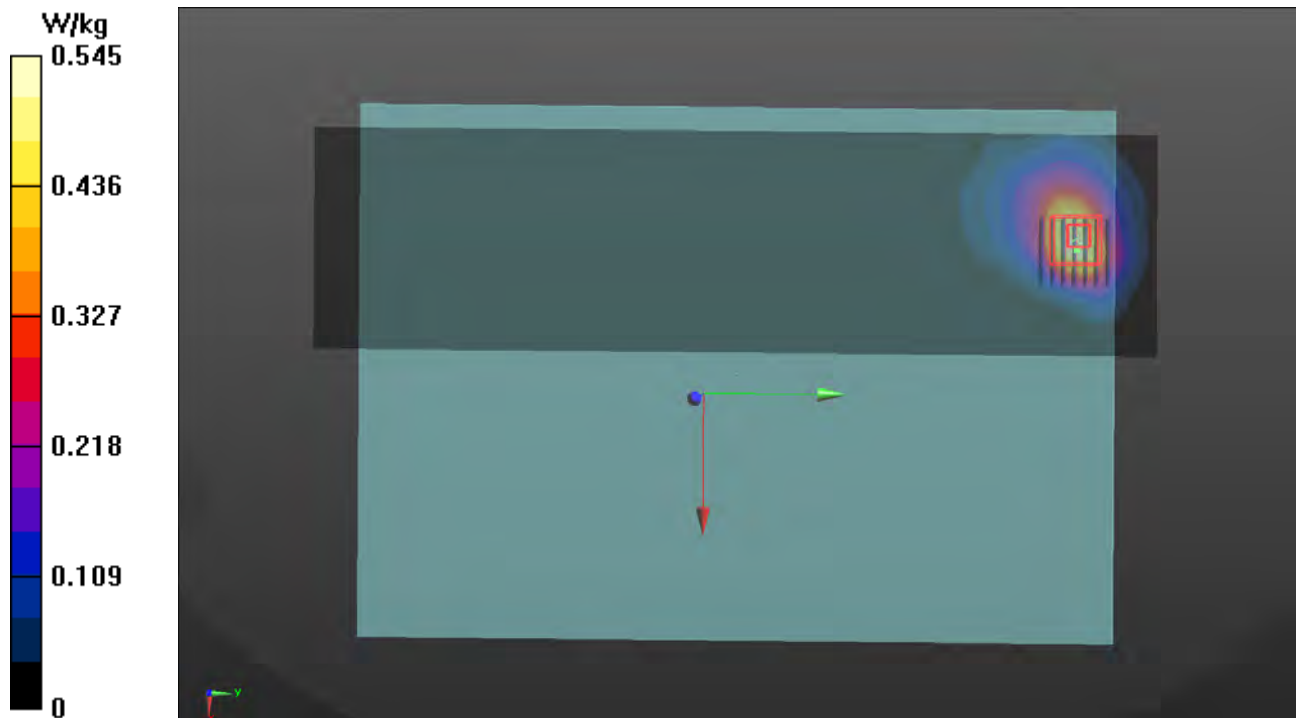

## Plots of Measurement

Test Laboratory: Bureau Veritas ADT SAR/HAC Testing Lab

Date: 2022/3/25

**P26 5GNR-n25\_DFT-S QPSK20M\_Bottom\_0mm\_Ch381000\_1RB\_OS1\_Ant 0\_Power Reduction\_w**

DUT: BFLF-WTW-P22030373

Communication System: UID 10931 - AAB, 5G NR (DFT-s-OFDM, 1 RB, 20 MHz, QPSK, 15 kHz); Frequency: 1905 MHz; Duty Cycle: 1:3.56

Medium: H16T20N1\_0325 Medium parameters used (interpolated):  $f = 1905$  MHz;  $\sigma = 1.46$  S/m;  $\epsilon_r = 39.683$ ;  $\rho = 1000$  kg/m<sup>3</sup>

Ambient Temperature : 23.6 °C ; Liquid Temperature : 23.4 °C

DASY5 Configuration:

- Probe: EX3DV4 - SN3578; ConvF(7.82, 7.82, 7.82) @ 1905 MHz; Calibrated: 2021/6/23
- Sensor-Surface: 1.4mm (Mechanical Surface Detection)
- Electronics: DAE4 Sn915; Calibrated: 2021/6/2
- Phantom: ELI Phantom\_1204; Type: QD OVA 002 Ax;
- Measurement SW: DASY52, Version 52.10 (4); SEMCAD X Version 14.6.14 (7501)

**Area Scan (71x261x1):** Interpolated grid: dx=1.500 mm, dy=1.500 mm  
Maximum value of SAR (interpolated) = 0.829 W/kg

**Zoom Scan (5x5x7)/Cube 0:** Measurement grid: dx=8mm, dy=8mm, dz=5mm

Reference Value = 21.36 V/m; Power Drift = -0.01 dB

Peak SAR (extrapolated) = 1.21 W/kg

**SAR(1 g) = 0.572 W/kg; SAR(10 g) = 0.312 W/kg** (SAR corrected for target medium)

Smallest distance from peaks to all points 3 dB below = 11.5 mm

Ratio of SAR at M2 to SAR at M1 = 51%

Maximum value of SAR (measured) = 0.969 W/kg

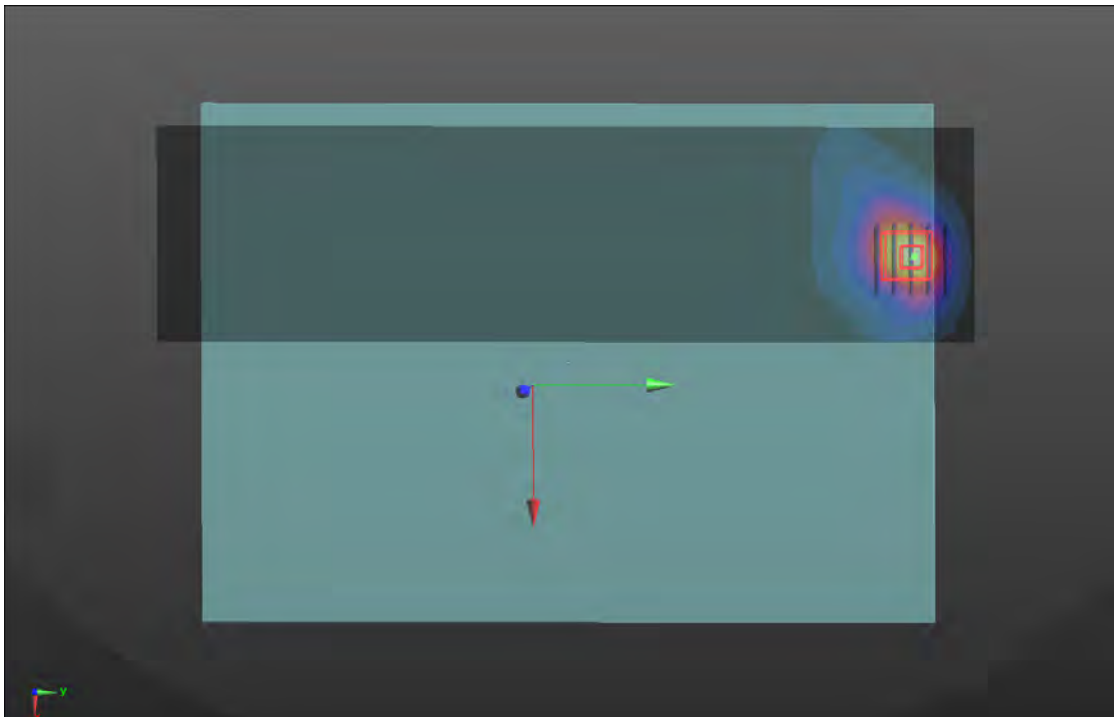

## Plots of Measurement

Test Laboratory: Bureau Veritas ADT SAR/HAC Testing Lab

Date: 2022/03/29

**P27 5GNR-n30\_DFT-S QPSK10M\_Bottom for Laptop\_0mm\_Ch462000\_1RB\_OS1\_Ant 0\_Power Reduction\_w**

**DUT: BFLF-WTW-P22030373**

Communication System: UID 10929 - AAB, 5G NR (DFT-s-OFDM, 1 RB, 10 MHz, QPSK, 15 kHz); Frequency: 2310 MHz; Duty Cycle: 1:3.56

Medium: H19T27N3\_0329 Medium parameters used:  $f = 2310$  MHz;  $\sigma = 1.698$  S/m;  $\epsilon_r = 38.289$ ;  $\rho = 1000$  kg/m<sup>3</sup>

Ambient Temperature : 23.4 °C ; Liquid Temperature : 23.3 °C

DASY5 Configuration:

- Probe: EX3DV4 - SN3578; ConvF(7.58, 7.58, 7.58) @ 2310 MHz; Calibrated: 2021/06/23
- Sensor-Surface: 1.4mm (Mechanical Surface Detection)
- Electronics: DAE4 Sn915; Calibrated: 2021/06/02
- Phantom: ELI Phantom\_1043; Type: QD OVA 002 Ax;
- Measurement SW: DASY52, Version 52.10 (4); SEMCAD X Version 14.6.14 (7501)

**Area Scan (91x321x1):** Interpolated grid: dx=1.200 mm, dy=1.200 mm

Maximum value of SAR (interpolated) = 1.02 W/kg

**Zoom Scan (7x7x7)/Cube 0:** Measurement grid: dx=5mm, dy=5mm, dz=5mm

Reference Value = 23.61 V/m; Power Drift = -0.11 dB

Peak SAR (extrapolated) = 1.30 W/kg

**SAR(1 g) = 0.577 W/kg; SAR(10 g) = 0.375 W/kg** (SAR corrected for target medium)

Smallest distance from peaks to all points 3 dB below = 14.8 mm

Ratio of SAR at M2 to SAR at M1 = 49.3%

Maximum value of SAR (measured) = 1.03 W/kg

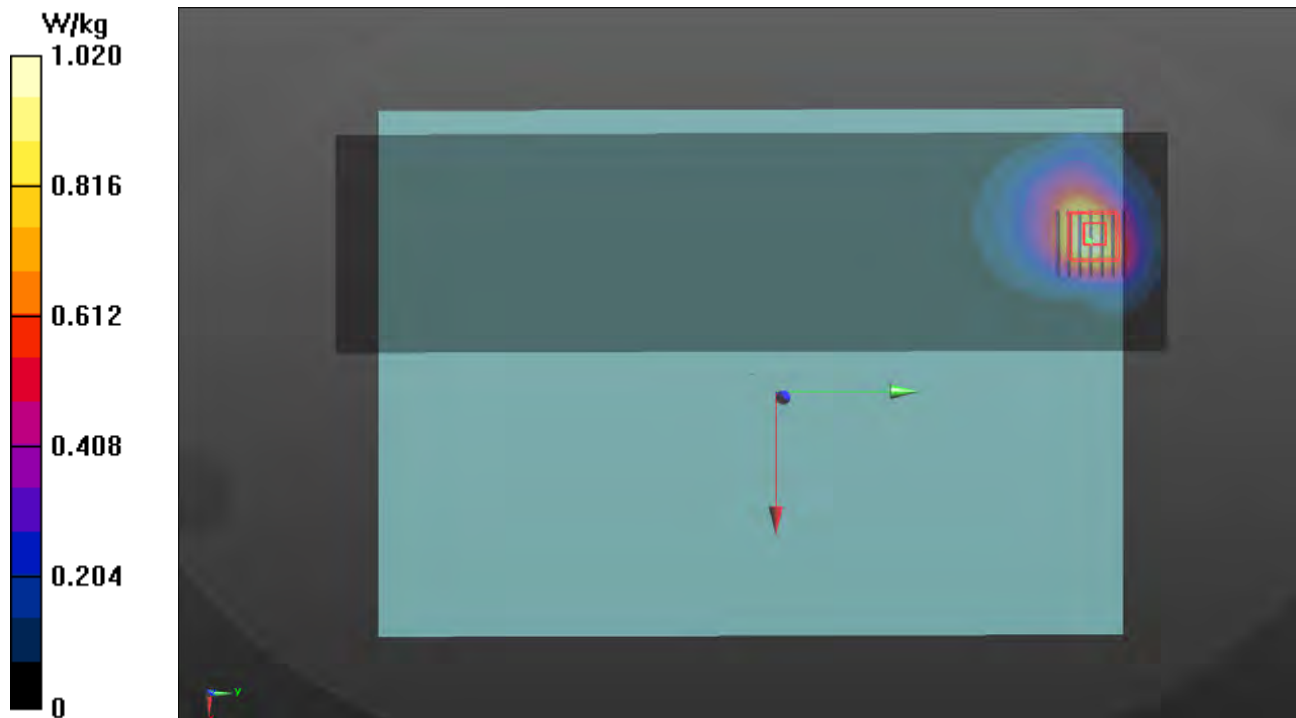

## Plots of Measurement

Test Laboratory: Bureau Veritas ADT SAR/HAC Testing Lab

Date: 2022/03/29

**P28 5GNR-n38\_DFT-S QPSK20M\_Bottom for Laptop\_0mm\_Ch519000\_1RB\_OS1\_Ant 0\_Power Reduction\_w**

**DUT: BFLF-WTW-P22030373**

Communication System: UID 10900 - AAB, 5G NR (DFT-s-OFDM, 1 RB, 20 MHz, QPSK, 30 kHz); Frequency: 2595 MHz; Duty Cycle: 1:3.7

Medium: H19T27N3\_0329 Medium parameters used (interpolated):  $f = 2595$  MHz;  $\sigma = 1.911$  S/m;  $\epsilon_r = 37.816$ ;  $\rho = 1000$  kg/m<sup>3</sup>

Ambient Temperature : 23.4 °C ; Liquid Temperature : 23.3 °C

DASY5 Configuration:

- Probe: EX3DV4 - SN3578; ConvF(7.22, 7.22, 7.22) @ 2595 MHz; Calibrated: 2021/06/23
- Sensor-Surface: 1.4mm (Mechanical Surface Detection)
- Electronics: DAE4 Sn915; Calibrated: 2021/06/02
- Phantom: ELI Phantom\_1043; Type: QD OVA 002 Ax;
- Measurement SW: DASY52, Version 52.10 (4); SEMCAD X Version 14.6.14 (7501)

**Area Scan (91x321x1):** Interpolated grid: dx=1.200 mm, dy=1.200 mm  
Maximum value of SAR (interpolated) = 2.64 W/kg

**Zoom Scan (7x7x7)/Cube 0:** Measurement grid: dx=5mm, dy=5mm, dz=5mm

Reference Value = 36.96 V/m; Power Drift = -0.15 dB

Peak SAR (extrapolated) = 1.37 W/kg

**SAR(1 g) = 0.529 W/kg; SAR(10 g) = 0.221 W/kg** (SAR corrected for target medium)

Smallest distance from peaks to all points 3 dB below = 12 mm

Ratio of SAR at M2 to SAR at M1 = 50.1%

Maximum value of SAR (measured) = 1.05 W/kg

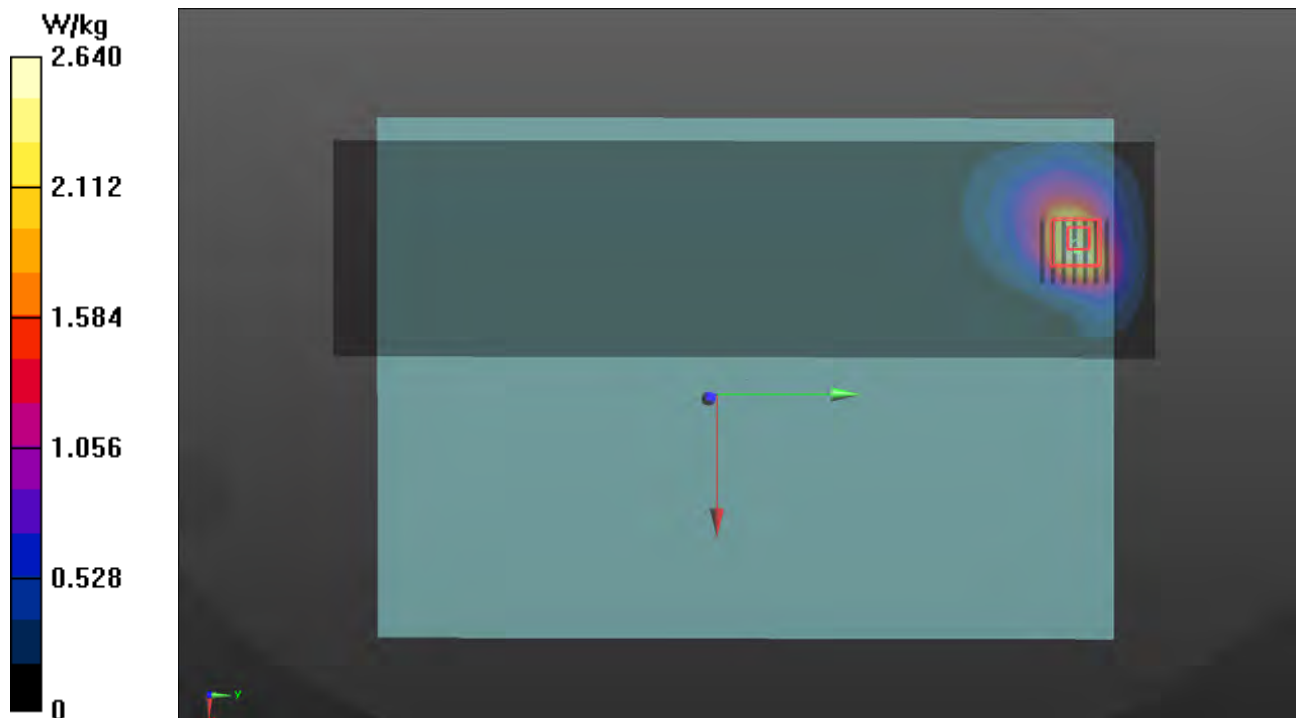

## Plots of Measurement

Test Laboratory: Bureau Veritas ADT SAR/HAC Testing Lab

Date: 2022/03/30

**P29 5GNR-n40\_DFT-S QPSK80M\_Bottom for Laptop\_0mm\_Ch468000\_1RB\_OS1\_Ant 0\_Power Reduction\_w**

**DUT: BFLF-WTW-P22030373**

Communication System: UID 10906 - AAB, 5G NR (DFT-s-OFDM, 1 RB, 80 MHz, QPSK, 30 kHz); Frequency: 2340 MHz; Duty Cycle: 1:3.7

Medium: H19T27N1\_0330 Medium parameters used:  $f = 2340$  MHz;  $\sigma = 1.76$  S/m;  $\epsilon_r = 38.908$ ;  $\rho = 1000$  kg/m<sup>3</sup>

Ambient Temperature : 23.3 °C ; Liquid Temperature : 23.1 °C

DASY5 Configuration:

- Probe: EX3DV4 - SN3578; ConvF(7.58, 7.58, 7.58) @ 2340 MHz; Calibrated: 2021/06/23
- Sensor-Surface: 1.4mm (Mechanical Surface Detection)
- Electronics: DAE4 Sn915; Calibrated: 2021/06/02
- Phantom: ELI Phantom\_1043; Type: QD OVA 002 Ax;
- Measurement SW: DASY52, Version 52.10 (4); SEMCAD X Version 14.6.14 (7501)

**Area Scan (91x321x1):** Interpolated grid: dx=1.200 mm, dy=1.200 mm

Maximum value of SAR (interpolated) = 0.759 W/kg

**Zoom Scan (7x7x7)/Cube 0:** Measurement grid: dx=5mm, dy=5mm, dz=5mm

Reference Value = 20.27 V/m; Power Drift = -0.12 dB

Peak SAR (extrapolated) = 0.963 W/kg

**SAR(1 g) = 0.517 W/kg; SAR(10 g) = 0.273 W/kg** (SAR corrected for target medium)

Smallest distance from peaks to all points 3 dB below = 15.7 mm

Ratio of SAR at M2 to SAR at M1 = 51.8%

Maximum value of SAR (measured) = 0.757 W/kg

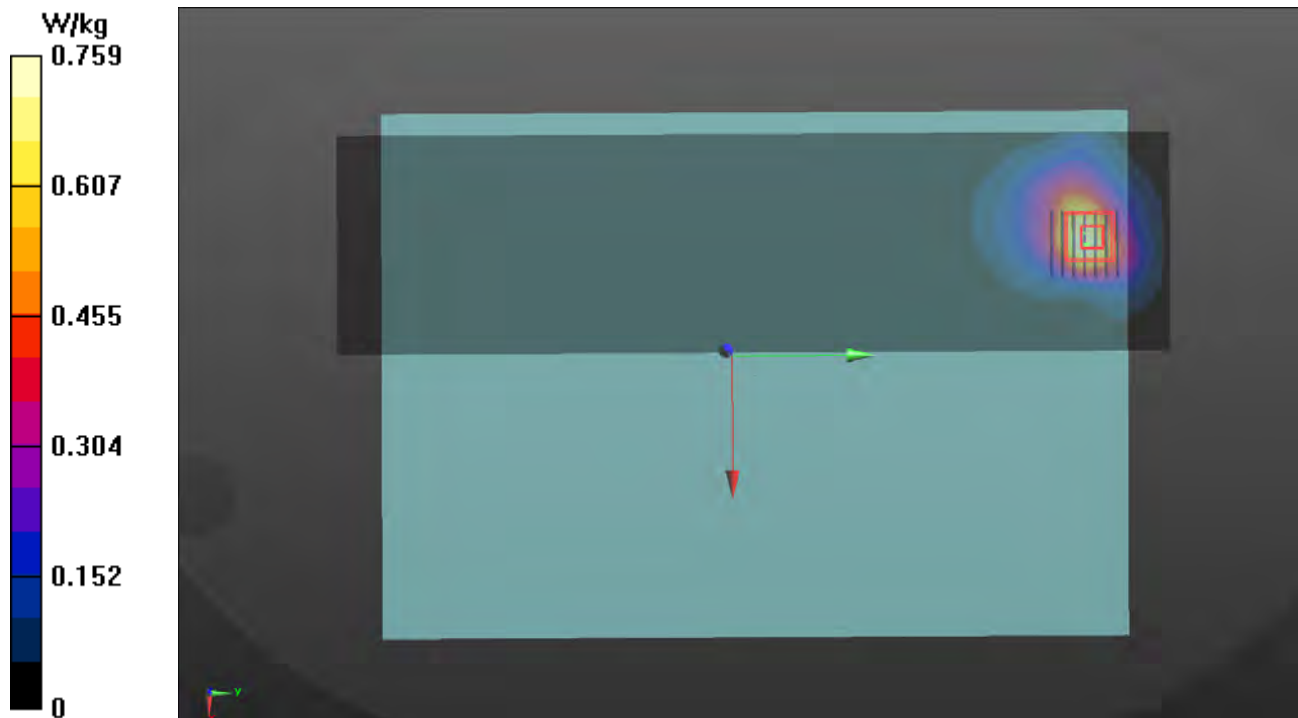

## Plots of Measurement

Test Laboratory: Bureau Veritas ADT SAR/HAC Testing Lab

Date: 2022/04/03

**P30 5GNR-n41\_DFT-S QPSK100M\_Bottom for Laptop\_0mm\_Ch509202\_1RB\_OS1\_Ant 2\_Reduction\_w**

**DUT: BFLF-WTW-P22030373**

Communication System: UID 10866 - AAD, 5G NR (DFT-s-OFDM, 1 RB, 100 MHz, QPSK, 30 kHz); Frequency: 2546.01 MHz; Duty Cycle: 1:3.7

Medium: H19T27N1\_0403 Medium parameters used (interpolated):  $f = 2546.01$  MHz;  $\sigma = 1.922$  S/m;  $\epsilon_r = 38.606$ ;  $\rho = 1000$  kg/m<sup>3</sup>

Ambient Temperature : 23.8 °C ; Liquid Temperature : 23.6 °C

DASY5 Configuration:

- Probe: EX3DV4 - SN3578; ConvF(7.22, 7.22, 7.22) @ 2546.01 MHz; Calibrated: 2021/06/23
- Sensor-Surface: 1.4mm (Mechanical Surface Detection)
- Electronics: DAE4 Sn915; Calibrated: 2021/06/02
- Phantom: ELI Phantom\_1043; Type: QD OVA 002 Ax;
- Measurement SW: DASY52, Version 52.10 (4); SEMCAD X Version 14.6.14 (7501)

**Area Scan (91x321x1):** Interpolated grid:  $dx=1.200$  mm,  $dy=1.200$  mm  
Maximum value of SAR (interpolated) = 0.891 W/kg

**Zoom Scan (7x7x7)/Cube 0:** Measurement grid:  $dx=5$ mm,  $dy=5$ mm,  $dz=5$ mm

Reference Value = 20.17 V/m; Power Drift = 0.02 dB

Peak SAR (extrapolated) = 1.44 W/kg

**SAR(1 g) = 0.583 W/kg; SAR(10 g) = 0.219 W/kg** (SAR corrected for target medium)

Smallest distance from peaks to all points 3 dB below = 10.2 mm

Ratio of SAR at M2 to SAR at M1 = 50%

Maximum value of SAR (measured) = 1.11 W/kg

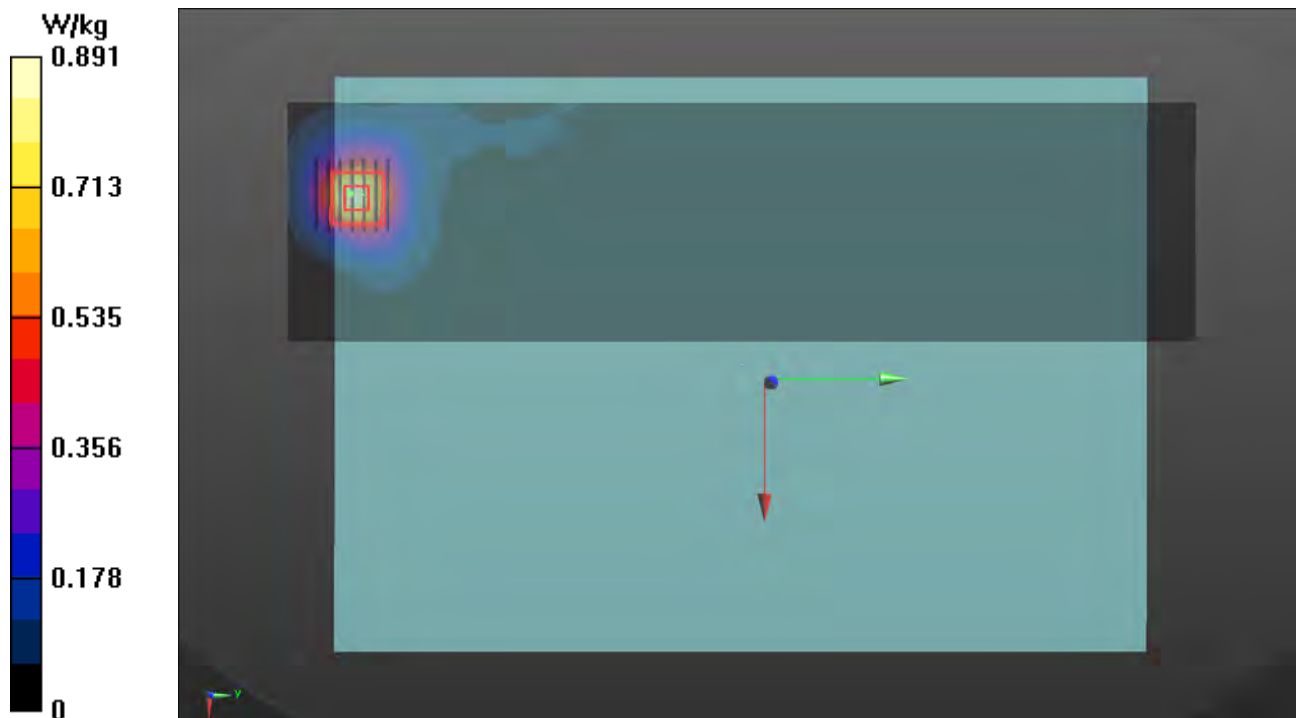

## Plots of Measurement

Test Laboratory: Bureau Veritas ADT SAR/HAC Testing Lab

Date: 2022/3/25

**P32 5GNR-n66\_DFT-S QPSK40M\_Bottom for Laptop\_0mm\_Ch349000\_1RB\_OS1\_Ant 0\_Power Reduction\_w**

DUT: BFLF-WTW-P22030373

Communication System: UID 10934 - AAC, 5G NR (DFT-s-OFDM, 1 RB, 40 MHz, QPSK, 15 kHz); Frequency: 1745 MHz; Duty Cycle: 1:3.56

Medium: H16T20N1\_0325 Medium parameters used (interpolated):  $f = 1745$  MHz;  $\sigma = 1.316$  S/m;  $\epsilon_r = 40.279$ ;  $\rho = 1000$  kg/m<sup>3</sup>

Ambient Temperature : 23.6 °C ; Liquid Temperature : 23.4 °C

DASY5 Configuration:

- Probe: EX3DV4 - SN3578; ConvF(8.09, 8.09, 8.09) @ 1745 MHz; Calibrated: 2021/6/23
- Sensor-Surface: 1.4mm (Mechanical Surface Detection)
- Electronics: DAE4 Sn915; Calibrated: 2021/6/2
- Phantom: ELI Phantom\_1204; Type: QD OVA 002 Ax;
- Measurement SW: DASY52, Version 52.10 (4); SEMCAD X Version 14.6.14 (7501)

**Area Scan (71x261x1):** Interpolated grid:  $dx=1.500$  mm,  $dy=1.500$  mm  
Maximum value of SAR (interpolated) = 0.651 W/kg

**Zoom Scan (5x5x7)/Cube 0:** Measurement grid:  $dx=8$ mm,  $dy=8$ mm,  $dz=5$ mm

Reference Value = 21.30 V/m; Power Drift = -0.04 dB

Peak SAR (extrapolated) = 0.984 W/kg

**SAR(1 g) = 0.541 W/kg; SAR(10 g) = 0.293 W/kg** (SAR corrected for target medium)

Smallest distance from peaks to all points 3 dB below = 12.2 mm

Ratio of SAR at M2 to SAR at M1 = 53.3%

Maximum value of SAR (measured) = 0.812 W/kg

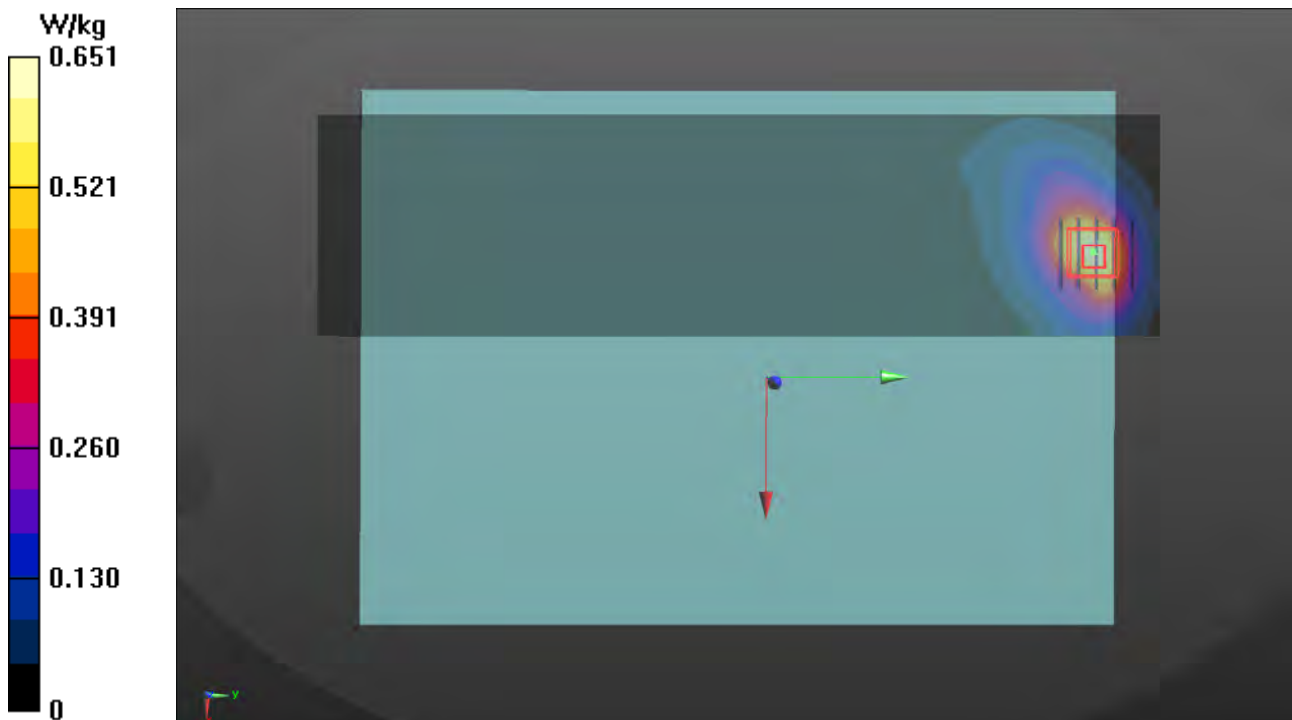



## Plots of Measurement

Test Laboratory: Bureau Veritas ADT SAR/HAC Testing Lab

Date: 2022/03/27

**P33 5GNR-n71\_DFT-S QPSK20M\_Bottom for Laptop\_0mm\_Ch136100\_1RB\_OS1\_Ant 0\_Power Reduction\_w**

**DUT: BFLF-WTW-P22030373**

Communication System: UID 10931 - AAB, 5G NR (DFT-s-OFDM, 1 RB, 20 MHz, QPSK, 15 kHz); Frequency: 680.5 MHz; Duty Cycle: 1:3.56

Medium: H06T09N1\_0327 Medium parameters used (interpolated):  $f = 680.5$  MHz;  $\sigma = 0.893$  S/m;  $\epsilon_r = 41.018$ ;  $\rho = 1000$  kg/m<sup>3</sup>

Ambient Temperature : 23.7 °C ; Liquid Temperature : 23.5 °C

DASY5 Configuration:

- Probe: EX3DV4 - SN3578; ConvF(10.02, 10.02, 10.02) @ 680.5 MHz; Calibrated: 2021/06/23
- Sensor-Surface: 1.4mm (Mechanical Surface Detection)
- Electronics: DAE4 Sn915; Calibrated: 2021/06/02
- Phantom: ELI Phantom\_1043; Type: QD OVA 002 Ax;
- Measurement SW: DASY52, Version 52.10 (4); SEMCAD X Version 14.6.14 (7501)

**Area Scan (71x261x1):** Interpolated grid: dx=1.500 mm, dy=1.500 mm  
Maximum value of SAR (interpolated) = 0.971 W/kg

**Zoom Scan (5x5x7)/Cube 0:** Measurement grid: dx=8mm, dy=8mm, dz=5mm

Reference Value = 34.40 V/m; Power Drift = 0.04 dB

Peak SAR (extrapolated) = 1.19 W/kg

**SAR(1 g) = 0.634 W/kg; SAR(10 g) = 0.384 W/kg** (SAR corrected for target medium)

Smallest distance from peaks to all points 3 dB below = 11.2 mm

Ratio of SAR at M2 to SAR at M1 = 57%

Maximum value of SAR (measured) = 0.997 W/kg

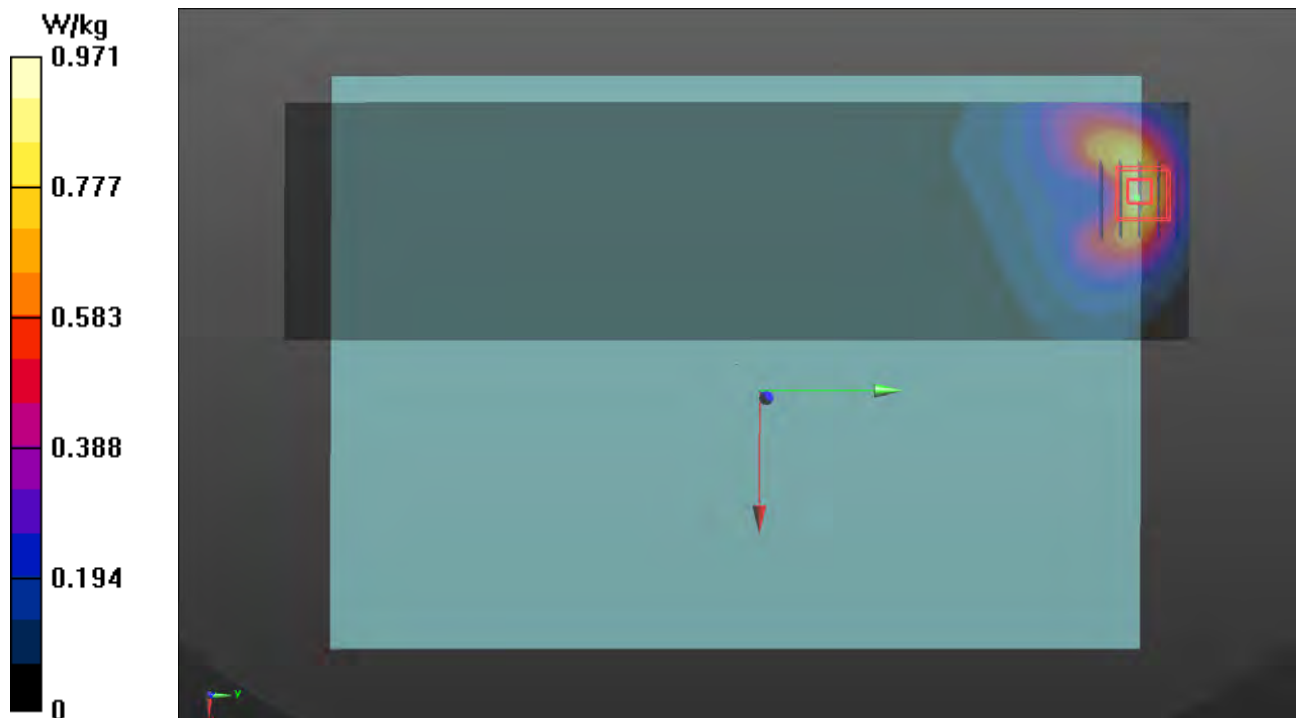

## Plots of Measurement

Test Laboratory: Bureau Veritas ADT SAR/HAC Testing Lab

Date: 2022/04/03

**P34 5GNR-n77\_DFT-S QPSK100M\_Bottom\_0mm\_Ch659000\_1RB\_OS1\_Ant 2\_Power Reduction\_w**

**DUT: BFLF-WTW-P22030373**

Communication System: UID 10866 - AAD, 5G NR (DFT-s-OFDM, 1 RB, 100 MHz, QPSK, 30 kHz); Frequency: 3885 MHz; Duty Cycle: 1:3.7

Medium: H33T42N2\_0403 Medium parameters used (interpolated):  $f = 3885$  MHz;  $\sigma = 3.22$  S/m;  $\epsilon_r = 37.951$ ;  $\rho = 1000$  kg/m<sup>3</sup>

Ambient Temperature : 23.8 °C ; Liquid Temperature : 23.6 °C

DASY5 Configuration:

- Probe: EX3DV4 - SN3578; ConvF(6.81, 6.81, 6.81) @ 3885 MHz; Calibrated: 2021/06/23
- Sensor-Surface: 1.4mm (Mechanical Surface Detection)
- Electronics: DAE4 Sn915; Calibrated: 2021/06/02
- Phantom: ELI Phantom\_1043; Type: QD OVA 002 Ax;
- Measurement SW: DASY52, Version 52.10 (4); SEMCAD X Version 14.6.14 (7501)

**Area Scan (91x321x1):** Interpolated grid: dx=1.200 mm, dy=1.200 mm  
Maximum value of SAR (interpolated) = 1.17 W/kg

**Zoom Scan (7x7x7)/Cube 0:** Measurement grid: dx=5mm, dy=5mm, dz=2.5mm  
Reference Value = 18.66 V/m; Power Drift = -0.09 dB

Peak SAR (extrapolated) = 1.77 W/kg

**SAR(1 g) = 0.658 W/kg; SAR(10 g) = 0.277 W/kg** (SAR corrected for target medium)

Smallest distance from peaks to all points 3 dB below = 8.1 mm

Ratio of SAR at M2 to SAR at M1 = 58.7%

Maximum value of SAR (measured) = 1.28 W/kg

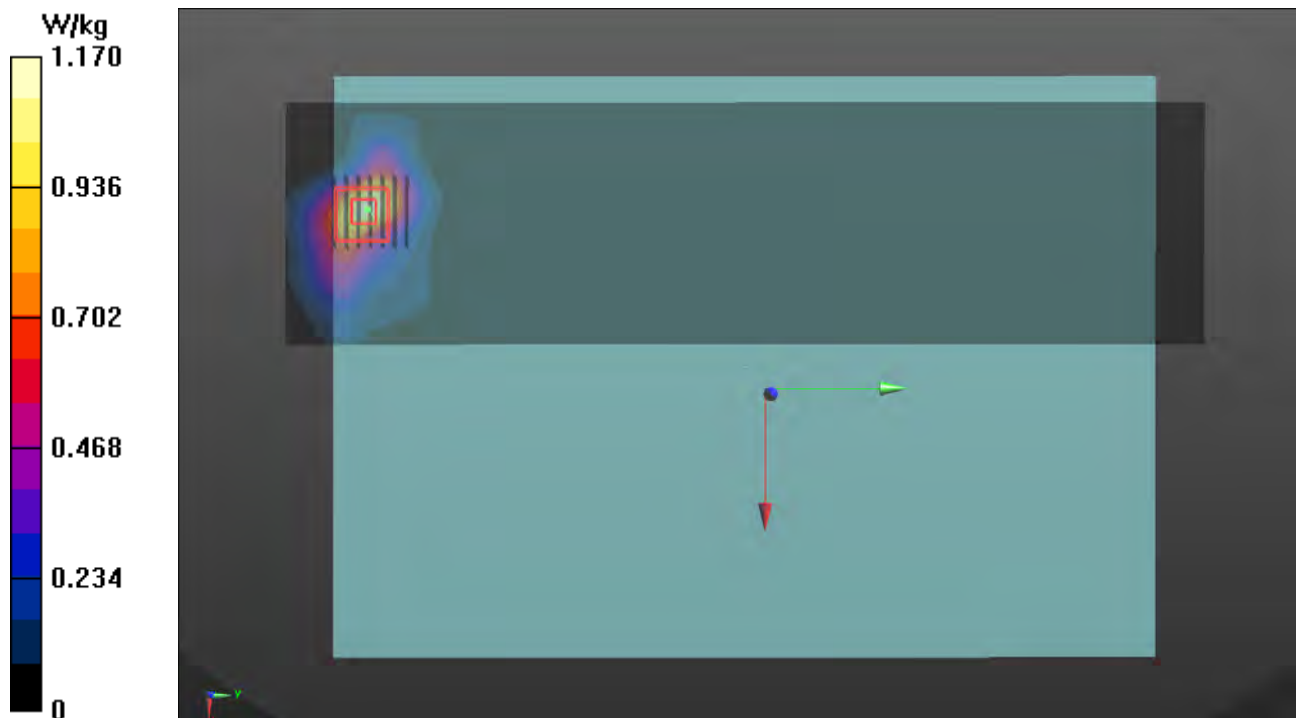

## Plots of Measurement

Test Laboratory: Bureau Veritas ADT SAR/HAC Testing Lab

Date: 2022/04/03

**P35 5GNR-n78\_DFT-S QPSK100M\_Bottom\_0mm\_Ch650000\_1RB\_OS1\_Ant 2\_Power Reduction\_w**

**DUT: BFLF-WTW-P22030373**

Communication System: UID 10866 - AAD, 5G NR (DFT-s-OFDM, 1 RB, 100 MHz, QPSK, 30 kHz); Frequency: 3750 MHz; Duty Cycle: 1:3.7

Medium: H33T42N2\_0403 Medium parameters used:  $f = 3750$  MHz;  $\sigma = 3.076$  S/m;  $\epsilon_r = 38.182$ ;  $\rho = 1000$  kg/m<sup>3</sup>

Ambient Temperature : 23.8 °C ; Liquid Temperature : 23.6 °C

DASY5 Configuration:

- Probe: EX3DV4 - SN3578; ConvF(6.96, 6.96, 6.96) @ 3750 MHz; Calibrated: 2021/06/23
- Sensor-Surface: 1.4mm (Mechanical Surface Detection)
- Electronics: DAE4 Sn915; Calibrated: 2021/06/02
- Phantom: ELI Phantom\_1043; Type: QD OVA 002 Ax;
- Measurement SW: DASY52, Version 52.10 (4); SEMCAD X Version 14.6.14 (7501)

**Area Scan (91x321x1):** Interpolated grid: dx=1.200 mm, dy=1.200 mm

Maximum value of SAR (interpolated) = 1.21 W/kg

**Zoom Scan (7x7x7)/Cube 0:** Measurement grid: dx=5mm, dy=5mm, dz=2.5mm

Reference Value = 20.58 V/m; Power Drift = -0.06 dB

Peak SAR (extrapolated) = 1.78 W/kg

**SAR(1 g) = 0.654 W/kg; SAR(10 g) = 0.278 W/kg** (SAR corrected for target medium)

Smallest distance from peaks to all points 3 dB below = 8.1 mm

Ratio of SAR at M2 to SAR at M1 = 57.7%

Maximum value of SAR (measured) = 1.27 W/kg

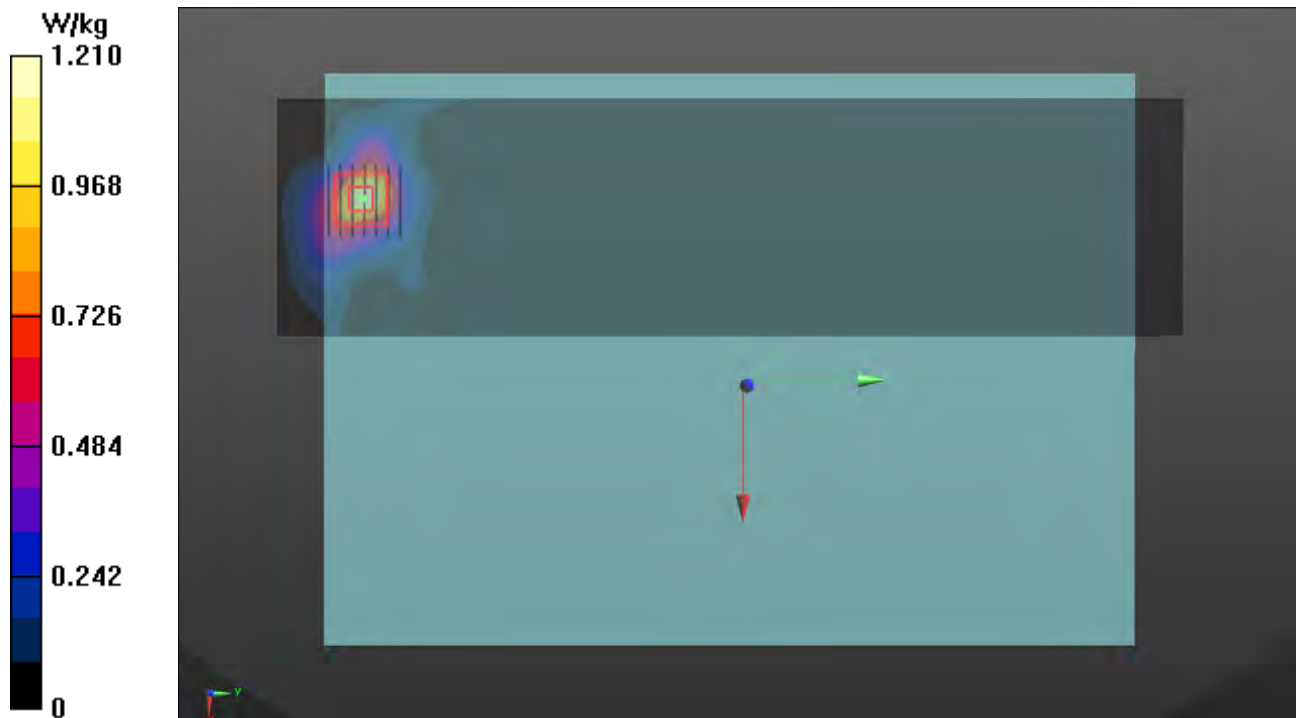

## Plots of Measurement

Test Laboratory: Bureau Veritas ADT SAR/HAC Testing Lab

Date: 2022/3/24

### P36 WLAN2.4G\_802.11n HT20\_Lid Closed Mode\_0mm\_Ch6\_Ant 0+1

DUT: BFLF-WTW-P22030373

Communication System: UID 10591 - AAC, IEEE 802.11n (HT Mixed, 20MHz, MCS0); Frequency: 2437 MHz; Duty Cycle: 1:1

Medium: H19T27N2\_0324 Medium parameters used (interpolated):  $f = 2437$  MHz;  $\sigma = 1.781$  S/m;  $\epsilon_r = 37.795$ ;  $\rho = 1000$  kg/m<sup>3</sup>

Ambient Temperature : 23.5 °C ; Liquid Temperature : 23.2 °C

DASY5 Configuration:

- Probe: EX3DV4 - SN3578; ConvF(7.34, 7.34, 7.34) @ 2437 MHz; Calibrated: 2021/6/23
- Sensor-Surface: 1.4mm (Mechanical Surface Detection)
- Electronics: DAE4 Sn915; Calibrated: 2021/6/2
- Phantom: ELI Phantom\_1204; Type: QD OVA 002 Ax;
- Measurement SW: DASY52, Version 52.10 (4); SEMCAD X Version 14.6.14 (7501)

**Area Scan (91x321x1):** Interpolated grid: dx=1.200 mm, dy=1.200 mm  
Maximum value of SAR (interpolated) = 0.208 W/kg

**Zoom Scan (7x7x7)/Cube 0:** Measurement grid: dx=5mm, dy=5mm, dz=5mm  
Reference Value = 11.03 V/m; Power Drift = -0.04 dB

Peak SAR (extrapolated) = 0.344 W/kg

**SAR(1 g) = 0.161 W/kg; SAR(10 g) = 0.093 W/kg** (SAR corrected for target medium)

Smallest distance from peaks to all points 3 dB below = 13.9 mm

Ratio of SAR at M2 to SAR at M1 = 54%

Maximum value of SAR (measured) = 0.286 W/kg

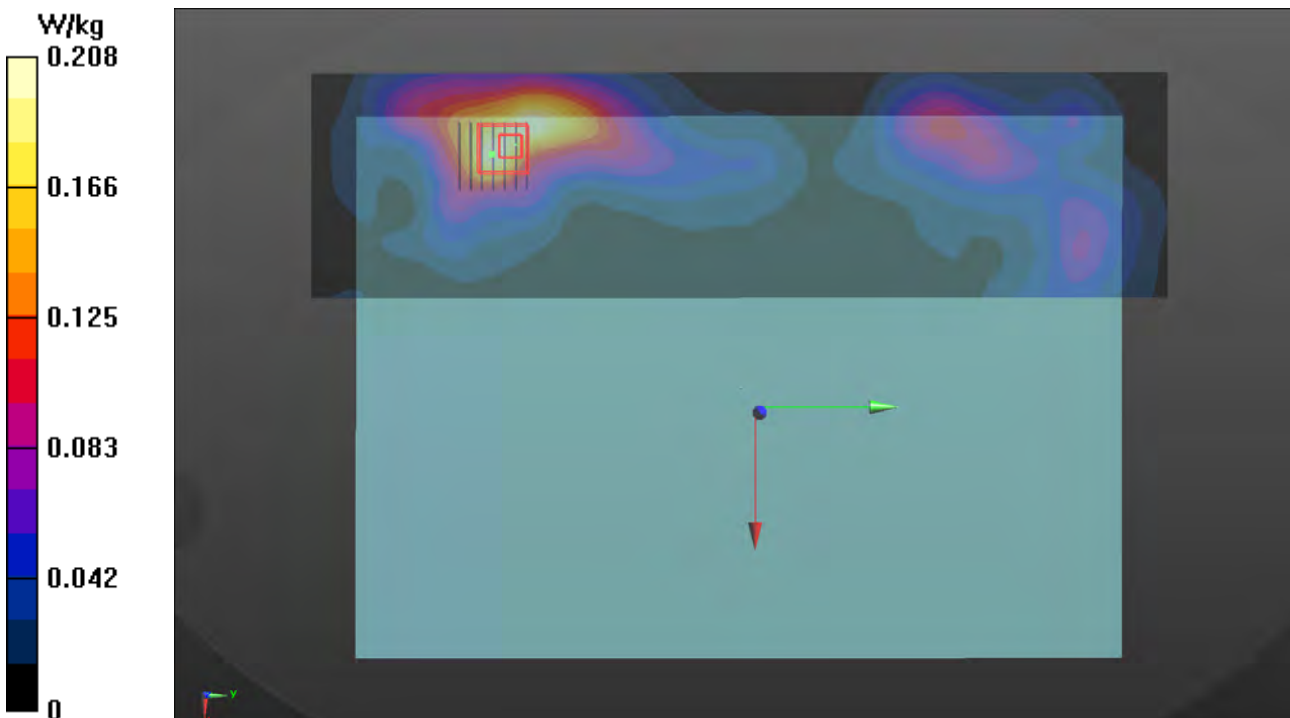

## Plots of Measurement

Test Laboratory: Bureau Veritas ADT SAR/HAC Testing Lab

Date: 2022/3/24

### P37 WLAN5.3G\_802.11n HT40\_Lid Close Mode\_0mm\_Ch54\_Ant 0+1

DUT: BFLF-WTW-P22030373

Communication System: UID 10599 - AAC, IEEE 802.11n (HT Mixed, 40MHz, MCS0); Frequency: 5270 MHz; Duty Cycle: 1:1.01

Medium: H34T60N1\_0324 Medium parameters used:  $f = 5270$  MHz;  $\sigma = 4.679$  S/m;  $\epsilon_r = 37.091$ ;  $\rho = 1000$  kg/m<sup>3</sup>

Ambient Temperature : 23.7 °C ; Liquid Temperature : 23.3 °C

DASY5 Configuration:

- Probe: EX3DV4 - SN3578; ConvF(5.39, 5.39, 5.39) @ 5270 MHz; Calibrated: 2021/6/23
- Sensor-Surface: 1.4mm (Mechanical Surface Detection)
- Electronics: DAE4 Sn915; Calibrated: 2021/6/2
- Phantom: ELI Phantom\_1204; Type: QD OVA 002 Ax;
- Measurement SW: DASY52, Version 52.10 (4); SEMCAD X Version 14.6.14 (7501)

**Area Scan (101x381x1):** Interpolated grid: dx=1.000 mm, dy=1.000 mm

Maximum value of SAR (interpolated) = 0.812 W/kg

**Zoom Scan (7x7x7)/Cube 0:** Measurement grid: dx=4mm, dy=4mm, dz=1.4mm

Reference Value = 13.59 V/m; Power Drift = -0.12 dB

Peak SAR (extrapolated) = 1.73 W/kg

**SAR(1 g) = 0.519 W/kg; SAR(10 g) = 0.191 W/kg** (SAR corrected for target medium)

Smallest distance from peaks to all points 3 dB below = 9.1 mm

Ratio of SAR at M2 to SAR at M1 = 67.3%

Maximum value of SAR (measured) = 1.13 W/kg

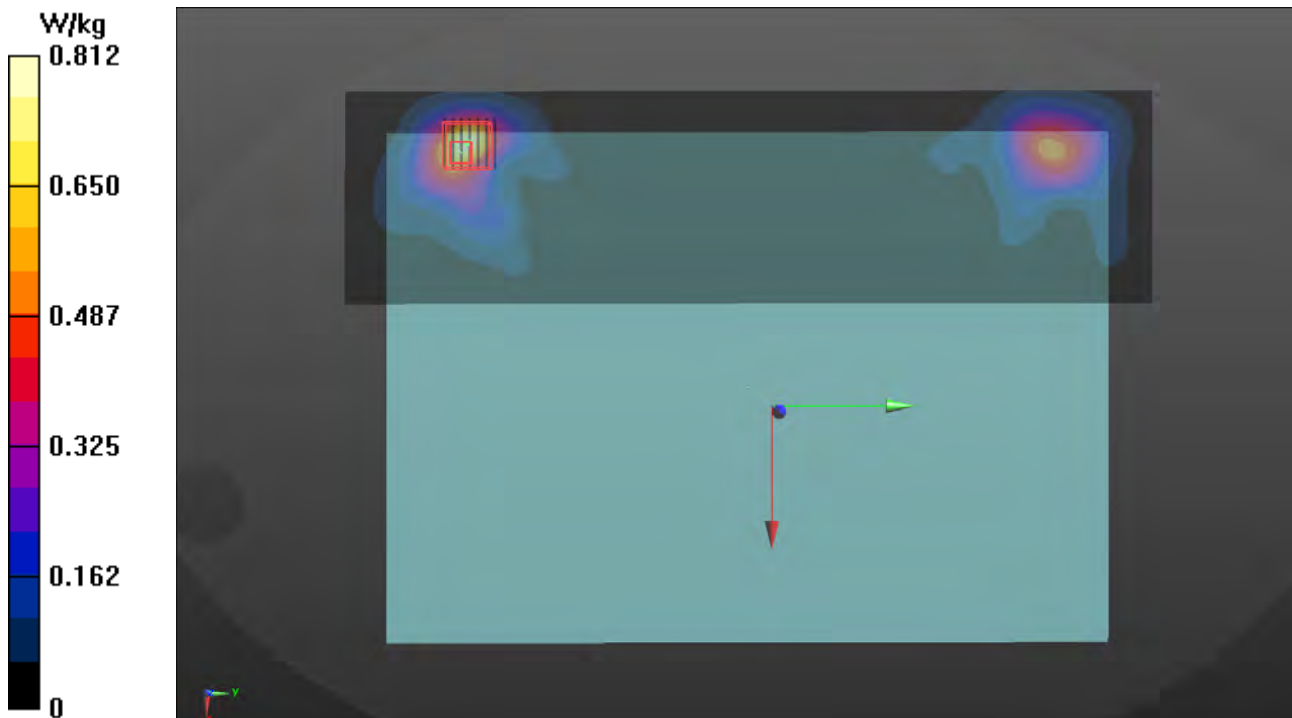

## Plots of Measurement

Test Laboratory: Bureau Veritas ADT SAR/HAC Testing Lab

Date: 2022/03/23

### P38 WLAN5.6G\_802.11ac VHT80\_Lid Closed Mode\_0mm\_Ch138\_Ant 1

DUT: BFLF-WTW-P22030373

Communication System: UID 10544 - AAC, IEEE 802.11ac WiFi (80MHz, MCS0); Frequency: 5690 MHz; Duty Cycle: 1:1.02

Medium: H34T60N1\_0323 Medium parameters used:  $f = 5690$  MHz;  $\sigma = 5.289$  S/m;  $\epsilon_r = 35.926$ ;  $\rho = 1000$  kg/m<sup>3</sup>

Ambient Temperature : 23.6 °C ; Liquid Temperature : 23.1 °C

DASY5 Configuration:

- Probe: EX3DV4 - SN3578; ConvF(5.05, 5.05, 5.05) @ 5690 MHz; Calibrated: 2021/6/23
- Sensor-Surface: 1.4mm (Mechanical Surface Detection)
- Electronics: DAE4 Sn915; Calibrated: 2021/6/2
- Phantom: ELI Phantom\_1204; Type: QD OVA 002 Ax;
- Measurement SW: DASY52, Version 52.10 (4); SEMCAD X Version 14.6.14 (7501)

**Area Scan (101x381x1):** Interpolated grid: dx=1.000 mm, dy=1.000 mm

Maximum value of SAR (interpolated) = 0.559 W/kg

**Zoom Scan (7x7x7)/Cube 0:** Measurement grid: dx=4mm, dy=4mm, dz=1.4mm

Reference Value = 11.04 V/m; Power Drift = -0.09 dB

Peak SAR (extrapolated) = 1.25 W/kg

**SAR(1 g) = 0.290 W/kg; SAR(10 g) = 0.113 W/kg** (SAR corrected for target medium)

Smallest distance from peaks to all points 3 dB below = 7.2 mm

Ratio of SAR at M2 to SAR at M1 = 60.6%

Maximum value of SAR (measured) = 0.723 W/kg

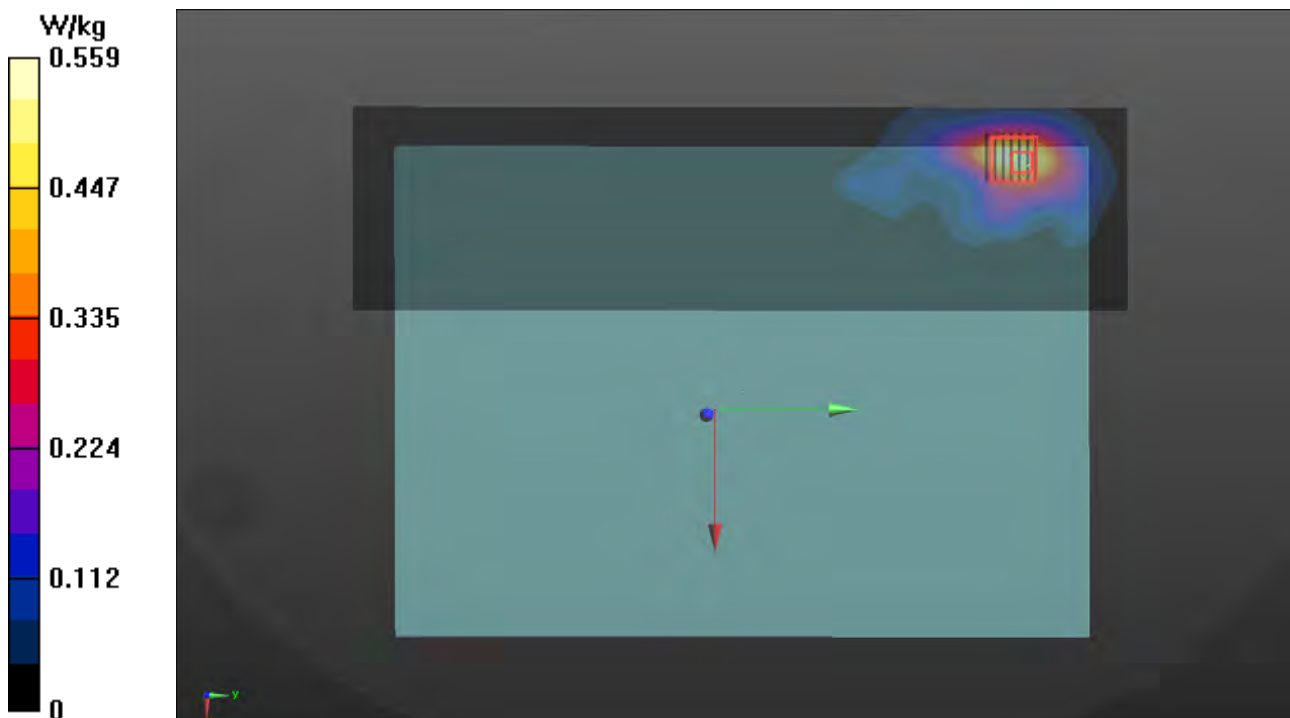

## Plots of Measurement

Test Laboratory: Bureau Veritas ADT SAR/HAC Testing Lab

Date: 2022/3/23

### P39 WLAN5.8G\_802.11ac VHT80\_Lid Close Mode\_0mm\_Ch155\_Ant 0

DUT: BFLF-WTW-P22030373

Communication System: UID 10544 - AAC, IEEE 802.11ac WiFi (80MHz, MCS0); Frequency: 5775 MHz; Duty Cycle: 1:1.02

Medium: H34T60N1\_0323 Medium parameters used:  $f = 5775$  MHz;  $\sigma = 5.386$  S/m;  $\epsilon_r = 35.786$ ;  $\rho = 1000$  kg/m<sup>3</sup>

Ambient Temperature : 23.6 °C ; Liquid Temperature : 23.1 °C

DASY5 Configuration:

- Probe: EX3DV4 - SN3578; ConvF(5.05, 5.05, 5.05) @ 5775 MHz; Calibrated: 2021/6/23
- Sensor-Surface: 1.4mm (Mechanical Surface Detection)
- Electronics: DAE4 Sn915; Calibrated: 2021/6/2
- Phantom: ELI Phantom\_1204; Type: QD OVA 002 Ax;
- Measurement SW: DASY52, Version 52.10 (4); SEMCAD X Version 14.6.14 (7501)

**Area Scan (101x381x1):** Interpolated grid: dx=1.000 mm, dy=1.000 mm

Maximum value of SAR (interpolated) = 1.020 W/kg

**Zoom Scan (7x7x7)/Cube 0:** Measurement grid: dx=4mm, dy=4mm, dz=1.4mm

Reference Value = 14.66 V/m; Power Drift = 0.13 dB

Peak SAR (extrapolated) = 3.43 W/kg

**SAR(1 g) = 0.744 W/kg; SAR(10 g) = 0.281 W/kg** (SAR corrected for target medium)

Smallest distance from peaks to all points 3 dB below = 6.8 mm

Ratio of SAR at M2 to SAR at M1 = 63.2%

Maximum value of SAR (measured) = 2.04 W/kg

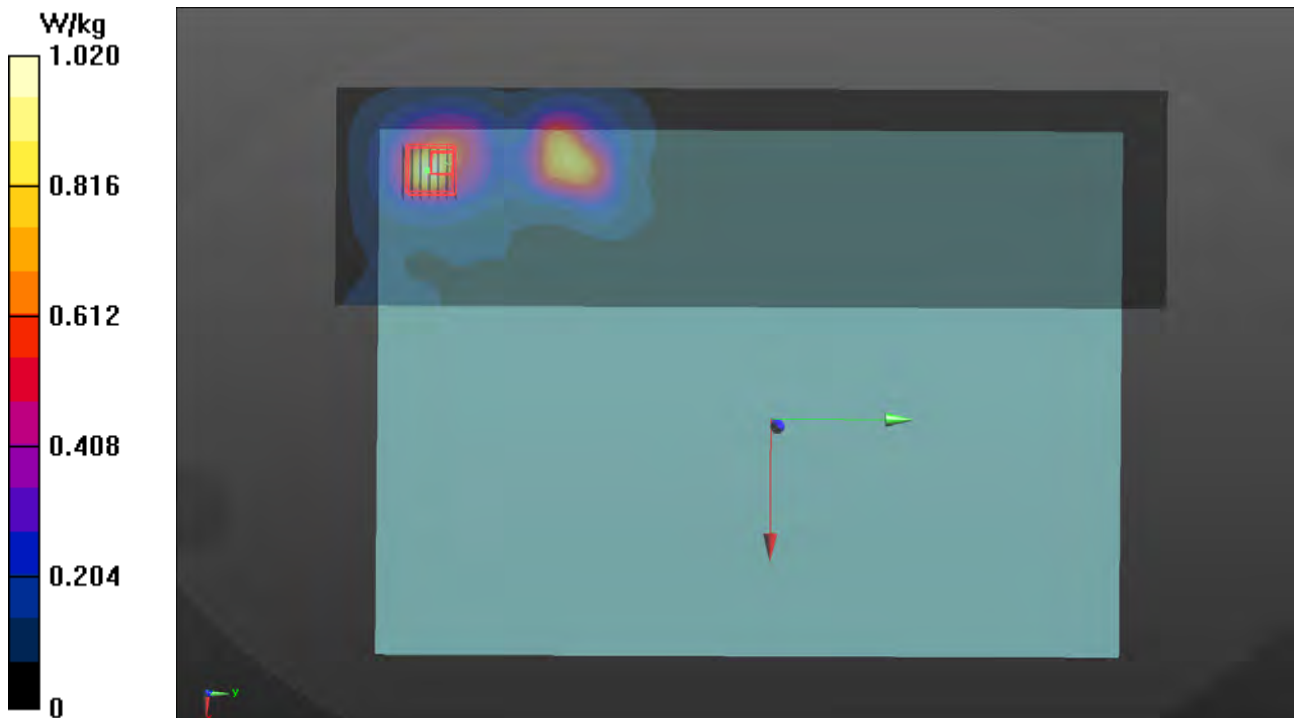

## Plots of Measurement

Test Laboratory: Bureau Veritas ADT SAR/HAC Testing Lab

Date: 2022/3/24

### P40 BT\_BDR\_Lid Closed Mode\_0mm\_Ch78\_Ant 1

DUT: BFLF-WTW-P22030373

Communication System: UID 10032 - CAA, IEEE 802.15.1 Bluetooth (GFSK, DH5); Frequency: 2480 MHz; Duty Cycle: 1:1.31

Medium: H19T27N2\_0324 Medium parameters used:  $f = 2480$  MHz;  $\sigma = 1.811$  S/m;  $\epsilon_r = 37.709$ ;  $\rho = 1000$  kg/m<sup>3</sup>

Ambient Temperature : 23.7 °C ; Liquid Temperature : 23.3 °C

DASY5 Configuration:

- Probe: EX3DV4 - SN3578; ConvF(7.34, 7.34, 7.34) @ 2480 MHz; Calibrated: 2021/6/23
- Sensor-Surface: 1.4mm (Mechanical Surface Detection)
- Electronics: DAE4 Sn915; Calibrated: 2021/6/2
- Phantom: ELI Phantom\_1204; Type: QD OVA 002 Ax;
- Measurement SW: DASY52, Version 52.10 (4); SEMCAD X Version 14.6.14 (7501)

**Area Scan (91x321x1):** Interpolated grid: dx=1.200 mm, dy=1.200 mm

Maximum value of SAR (interpolated) = 0.00935 W/kg

**Zoom Scan (7x7x7)/Cube 0:** Measurement grid: dx=5mm, dy=5mm, dz=5mm

Reference Value = 2.109 V/m; Power Drift = -0.08 dB

Peak SAR (extrapolated) = 0.00889 W/kg

**SAR(1 g) = 0.0051 W/kg; SAR(10 g) = 0.00309 W/kg** (SAR corrected for target medium)

Smallest distance from peaks to all points 3 dB below: Larger than measurement grid

Ratio of SAR at M2 to SAR at M1 = 59.8%

Maximum value of SAR (measured) = 0.00751 W/kg

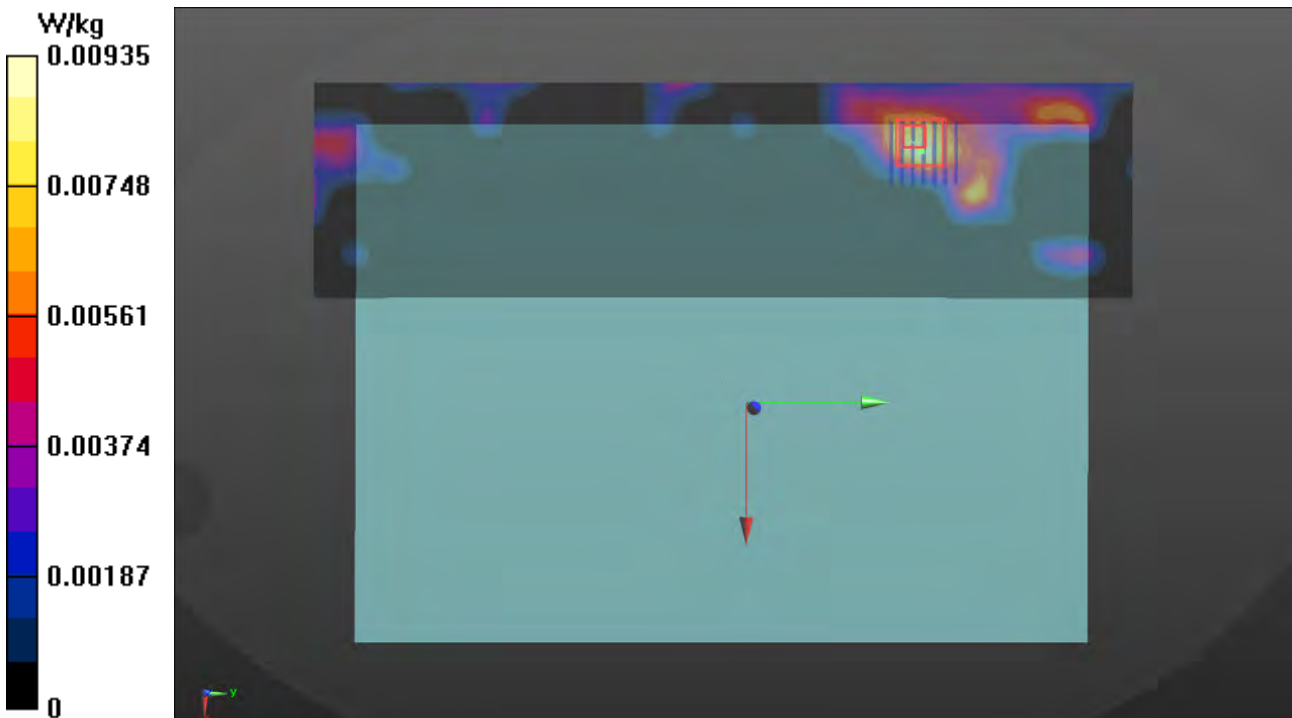



## Plots of Measurement

### Measurement Report for Device

**P41S UNII-5\_802.11ax HE160\_Lid Closed for Laptop\_0mm\_Ch15\_Ant 0**

#### Device under Test Properties

Name, Manufacturer	Dimensions [mm]	IMEI	DUT Type
BFLF-WTW-P22030373	340.0 x 236.0 x 20.0		NB

#### Exposure Conditions

Phantom Section, TSL	Position, Test Distance [mm]	Band	Group, UID	Frequency [MHz], Channel Number	Conversion Factor	TSL Conductivity [S/m]	TSL Permittivity
Flat, HSL	Lid Closed for Laptop 0.00	U-NII-5	WLAN, 10755-AAB	6025.0, 15	5.6	5.52	34.4

#### Hardware Setup

Phantom	TSL, Measured Date	Probe, Calibration Date	DAE, Calibration Date
ELI V5.0 (20deg probe tilt) - 1245	H50T72N1, 2022-May-05	EX3DV4 - SN3650, 2022-03-24	DAE4 Sn1341, 2021-08-20

#### Scan Setup

	Area Scan	Zoom Scan
Grid Extents [mm]	90.0 x 360.0	22.0 x 22.0 x 22.0
Grid Steps [mm]	7.5 x 7.5	3.4 x 3.4 x 1.4
Sensor Surface [mm]	3.0	1.4

#### Measurement Results

	Area Scan	Zoom Scan
Date	2022-05-05	2022-05-05
psSAR1g [W/Kg]	0.276	0.305
psSAR10g [W/Kg]	0.095	0.104
Power Drift [dB]	-0.15	0.05

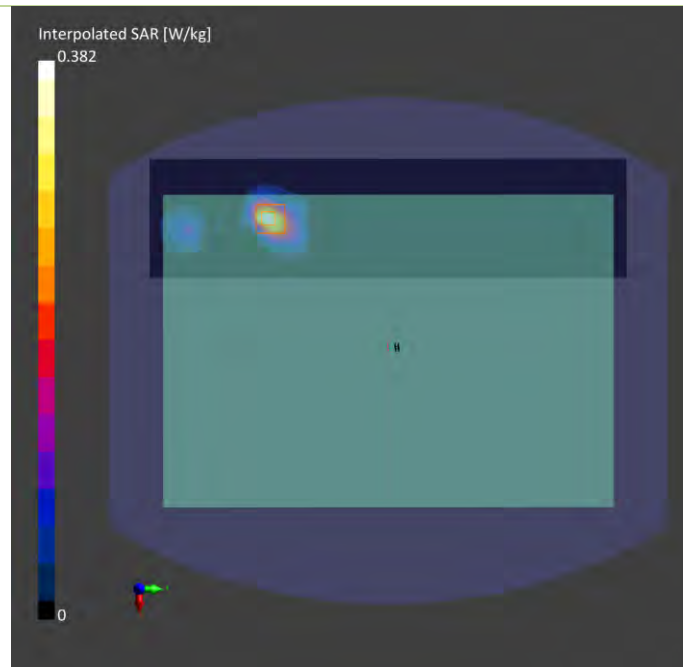

## Plots of Measurement

Test Lab: Bureau Veritas ADT SAR/HAC/PD Testing Lab

Power Density Plot No.:

P41P UNII-5\_802.11ax HE160\_Lid Closed for Laptop\_0mm\_Ch15\_Ant 0

Device under Test Properties

Name, Manufacturer	Dimensions [mm]	IMEI	DUT Type
BFLF-WTW-P22030373	340.0 x 236.0 x 20.0		NB

### Exposure Conditions

Phantom Section	Position, Test Distance [mm]	Band	Group, UID	Frequency [MHz], Channel Number	Conversion Factor
5GAir	Lid Closed for Laptop 2.00	U-NII-5	WLAN 10755	6025.0 15	1.0

### Hardware Setup

Phantom	Medium	Probe, Calibration Date	DAE, Calibration Date
mmWave	Air---	EUmmWV4 - SN9438_F1-55GHz, 2021-07-26	DAE4 Sn1341, 2021-08-20

### Scan Setup

	5G Scan
Grid Extents [mm]	120.0 x 120.0
Grid Steps [lambda]	0.25 x 0.25
Sensor Surface [mm]	2.0

### Measurement Results

	5G Scan
Date	2022-05-05
Avg. Area [cm <sup>2</sup> ]	4.00
pStotavg[W/m <sup>2</sup> ]	1.01
pSnavg [W/m <sup>2</sup> ]	1.01
E <sub>peak</sub> [V/m]	33.8
Power Drift [dB]	0.13

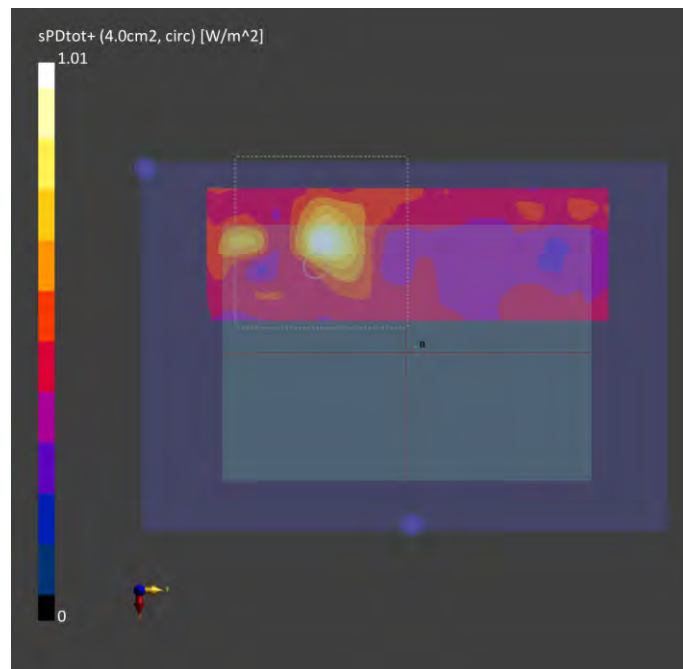

## **Annex C. Tissue & System Verification**

The measuring results for tissue simulating liquid and system check are shown as below.

Note:

1. For Section 4.3, the dielectric properties of the tissue simulating liquid have been measured within 24 hours before the SAR testing and within  $\pm 10\%$  of the target values. Liquid temperature during the SAR testing has kept within  $\pm 2\text{ }^{\circ}\text{C}$ .
2. For Section 4.4, The SAR measurement system was validated according to procedures in KDB 865664 D01. The validation status in tabulated summary is as below.
3. For Section 4.5, Comparing to the reference SAR value provided by SPEAG in dipole calibration certificate, the deviation of system check results is within its specification of 10 %. The result indicates the system check can meet the variation criterion and the plots please refer to Annex A of this report.



Plot No.	Test Date	Frequency [GHz]	mmWave Probe S/N	Verification Source S/N	Averaging Area [cm <sup>2</sup> ]	Distance [mm]	Target Power Density [W/m <sup>2</sup> ]	Measured Power Density [W/m <sup>2</sup> ]	Deviation [%]
S41P	May. 05, 2022	10	9438	1025	4	10.0	51.3	53.3	3.90%

## **Annex D. Maximum Target Conducted Power**

The maximum conducted average power (Unit: dBm) including tune-up tolerance is shown as below.

<b>WCDMA Max. Tune-up Power (Full)</b>		
<b>Mode</b>	<b>RMC 12.2K</b>	<b>HSDPA DC-HSDPA HSUPA</b>
	<b>Maximum Target Power</b>	<b>Maximum Target Power</b>
WCDMA Band II	24.5	24.5
WCDMA Band IV	24.5	24.5
WCDMA Band V	24.5	24.5

LTE Max. Tune-up Power (Full)				
Mode	QPSK	16QAM	64QAM	256QAM
	Maximum Target Power	Maximum Target Power	Maximum Target Power	Maximum Target Power
LTE 2	24.0	23.0	22.0	19.0
LTE 4	24.0	23.0	22.0	19.0
LTE 5	24.0	23.0	22.0	19.0
LTE 7	24.0	23.0	22.0	19.0
LTE 12	24.0	23.0	22.0	19.0
LTE 13	24.0	23.0	22.0	19.0
LTE 14	24.0	23.0	22.0	19.0
LTE 17	24.0	23.0	22.0	19.0
LTE 25	24.0	23.0	22.0	19.0
LTE 26	24.0	23.0	22.0	19.0
LTE 30	24.0	23.0	22.0	19.0
LTE 38	24.0	23.0	22.0	19.0
LTE 40	24.0	23.0	22.0	19.0
LTE 41(PC2)	27.0	26.0	25.0	22.0
LTE 41(PC3)	24.0	23.0	22.0	19.0
LTE 48	22.0	21.0	20.0	17.0
LTE 66	24.0	23.0	22.0	19.0
LTE 71	24.0	23.0	22.0	19.0



5G NR Max. Tune-up Power (Full)					
DFT-S Mode	PI/2 BPSK	QPSK	16QAM	64QAM	256QAM
	Maximum Target Power	Maximum Target Power	Maximum Target Power	Maximum Target Power	Maximum Target Power
NR 2	24.0	24.0	23.0	21.5	19.5
NR 5	24.0	24.0	23.0	21.5	19.5
NR 7	24.0	24.0	23.0	21.5	19.5
NR 25	24.0	24.0	23.0	21.5	19.5
NR 30	24.0	24.0	23.0	21.5	19.5
NR 38	24.0	24.0	23.0	21.5	19.5
NR 40	24.0	24.0	23.0	21.5	19.5
NR 41(PC2)	27.0	27.0	26.0	24.5	22.5
NR 41(PC3)	24.0	24.0	23.0	21.5	19.5
NR 66	24.0	24.0	23.0	21.5	19.5
NR 71	24.0	24.0	23.0	21.5	19.5
NR 77(PC2)	27.0	27.0	26.0	24.5	22.5
NR 77(PC3)	24.0	24.0	23.0	21.5	19.5
NR 78(PC2)	27.0	27.0	26.0	24.5	22.5
NR 78(PC3)	24.0	24.0	23.0	21.5	19.5

5G NR Max. Tune-up Power (Full)				
CP Mode	QPSK	16QAM	64QAM	256QAM
	Maximum Target Power	Maximum Target Power	Maximum Target Power	Maximum Target Power
NR 2	22.5	22.0	20.5	17.5
NR 5	22.5	22.0	20.5	17.5
NR 7	22.5	22.0	20.5	17.5
NR 25	22.5	22.0	20.5	17.5
NR 30	22.5	22.0	20.5	17.5
NR 38	22.5	22.0	20.5	17.5
NR 40	22.5	22.0	20.5	17.5
NR 41(PC2)	25.5	25.0	23.5	20.5
NR 41(PC3)	22.5	22.0	20.5	17.5
NR 66	22.5	22.0	20.5	17.5
NR 71	22.5	22.0	20.5	17.5
NR 77(PC2)	25.5	25.0	23.5	20.5
NR 77(PC3)	22.5	22.0	20.5	17.5
NR 78(PC2)	25.5	25.0	23.5	20.5
NR 78(PC3)	22.5	22.0	20.5	17.5

<b>WCDMA Max. Tune-up Power (Laptop)</b>		
<b>Mode</b>	<b>RMC 12.2K</b>	<b>HSDPA DC-HSDPA HSUPA</b>
	<b>Maximum Target Power</b>	<b>Maximum Target Power</b>
WCDMA Band II	17.5	17.5
WCDMA Band IV	18.5	18.5
WCDMA Band V	22.5	22.5

LTE Max. Tune-up Power (Laptop)				
Mode	QPSK	16QAM	64QAM	256QAM
	Maximum Target Power	Maximum Target Power	Maximum Target Power	Maximum Target Power
LTE 2	18.0	17.0	16.0	13.0
LTE 4	18.0	17.0	16.0	13.0
LTE 5	21.5	20.5	19.5	16.5
LTE 7	18.0	17.0	16.0	13.0
LTE 12	19.5	18.5	17.5	14.5
LTE 13	20.0	19.0	18.0	15.0
LTE 14	23.0	22.0	21.0	18.0
LTE 17	19.5	18.5	17.5	14.5
LTE 25	18.5	17.5	16.5	13.5
LTE 26	23.0	22.0	21.0	18.0
LTE 30	21.5	20.5	19.5	16.5
LTE 38	20.5	19.5	18.5	15.5
LTE 40	20.5	19.5	18.5	15.5
LTE 41	18.0	17.0	16.0	13.0
LTE 48	17.5	16.5	15.5	12.5
LTE 66	18.5	17.5	16.5	13.5
LTE 71	23.0	22.0	21.0	18.0

5G NR Max. Tune-up Power (Laptop)					
DFT-S Mode	PI/2 BPSK	QPSK	16QAM	64QAM	256QAM
	Maximum Target Power	Maximum Target Power	Maximum Target Power	Maximum Target Power	Maximum Target Power
NR 2	16.5	16.5	16.5	16.5	16.5
NR 5	20.0	20.0	20.0	20.0	20.0
NR 7	16.0	16.0	16.0	16.0	16.0
NR 25	16.5	16.5	16.5	16.5	16.5
NR 30	18.5	18.5	18.5	18.5	18.5
NR 38	19.0	19.0	19.0	19.0	19.0
NR 40	18.0	18.0	18.0	18.0	18.0
NR 41	17.0	17.0	17.0	17.0	17.0
NR 66	17.0	17.0	17.0	17.0	17.0
NR 71	20.0	20.0	20.0	20.0	20.0
NR 77	20.5	20.5	20.5	20.5	20.5
NR 78	21.0	21.0	21.0	21.0	21.0

5G NR Max. Tune-up Power (Laptop)				
CP Mode	QPSK	16QAM	64QAM	256QAM
	Maximum Target Power	Maximum Target Power	Maximum Target Power	Maximum Target Power
NR 2	15.0	13.0	11.5	8.5
NR 5	18.5	16.5	15.0	12.0
NR 7	14.5	12.5	11.0	8.0
NR 25	15.0	13.0	11.5	8.5
NR 30	17.0	15.0	13.5	10.5
NR 38	17.5	15.5	14.0	11.0
NR 40	16.5	14.5	13.0	10.0
NR 41	15.5	13.5	12.0	9.0
NR 66	15.5	13.5	12.0	9.0
NR 71	18.5	16.5	15.0	12.0
NR 77	19.0	17.0	15.5	12.5
NR 78	19.5	17.5	16.0	13.0

WLAN Tune-up Power (Laptop)							
WLAN 2.4GHz							
Mode	Channel	Frequency	SISO Ant 0 Max Tune up	SISO Ant 1 Max Tune up	MIMO Ant 0 Tune up	MIMO Ant 1 Tune up	MIMO Ant 0+1 Max Tune up
802.11b	1	2412	20.000	20.000			
	6	2437	20.000	20.000			
	11	2462	20.000	20.000			
	12	2467	18.750	19.250			
	13	2472	15.750	16.750			
802.11g	1	2412	19.500	19.250			
	6	2437	20.000	20.000			
	11	2462	18.000	18.250			
	12	2467	15.000	14.750			
	13	2472	11.750	12.000			
802.11n HT20	1	2412	19.500	19.250	16.500	16.500	19.500
	6	2437	20.000	20.000	20.000	20.000	23.000
	11	2462	18.000	18.250	16.500	16.500	19.500
	12	2467	15.000	14.750	11.250	11.250	14.250
	13	2472	11.750	12.000	8.500	8.500	11.500
802.11n HT40	3	2422	15.500	15.750	15.250	15.250	18.250
	6	2437	17.500	17.750	16.000	16.000	19.000
	9	2452	15.500	17.000	15.500	15.500	18.500
	10	2457	12.250	12.500	11.250	11.250	14.250
	11	2462	9.750	10.750	8.250	8.250	11.250
802.11ax HE20	1	2412	19.500	19.250	14.500	14.500	17.500
	6	2437	20.000	20.000	17.875	17.875	20.875
	11	2462	18.000	18.250	14.500	14.500	17.500
	12	2467	15.000	14.750	11.250	11.250	14.250
	13	2472	11.750	12.000	8.500	8.500	11.500
802.11ax HE40	3	2422	15.500	15.750	13.500	13.500	16.500
	6	2437	17.500	17.750	13.750	13.750	16.750
	9	2452	15.500	17.000	12.750	12.750	15.750
	10	2457	12.250	12.500	11.250	11.250	14.250
	11	2462	9.750	10.750	8.250	8.250	11.250

**WLAN Tune-up Power (Laptop)****Bluetooth**

Mode	Channel	Frequency	Ant 1 Max Tune-up
BDR	0	2402	10.5
	39	2441	10.5
	78	2480	10.5
LE	0	2402	7.0
	19	2440	7.0
	39	2480	7.0



WLAN Tune-up Power (Laptop)							
WLAN 5.2GHz							
Mode	Channel	Frequency	SISO Ant 0 Max Tune up	SISO Ant 1 Max Tune up	MIMO Ant 0 Tune up	MIMO Ant 1 Tune up	MIMO Ant 0+1 Max Tune up
802.11a	36	5180	19.500	19.500			
	40	5200	20.000	20.000			
	44	5220	20.000	20.000			
	48	5240	19.875	20.000			
802.11n HT20	36	5180	19.500	19.500	18.000	18.000	21.000
	40	5200	20.000	20.000	18.500	18.500	21.500
	44	5220	20.000	20.000	18.500	18.500	21.500
	48	5240	19.500	20.000	18.500	18.500	21.500
802.11n HT40	38	5190	17.750	18.750	15.500	15.500	18.500
	46	5230	20.000	20.000	20.000	20.000	23.000
802.11ac VHT80	42	5210	18.500	18.250	15.000	15.000	18.000
802.11ax HE20	36	5180	19.500	19.500	15.500	15.500	18.500
	40	5200	20.000	20.000	18.375	18.375	21.375
	44	5220	20.000	20.000	18.375	18.375	21.375
	48	5240	19.750	20.000	18.375	18.375	21.375
802.11ax HE40	38	5190	17.750	18.750	14.500	14.500	17.500
	46	5230	20.000	20.000	18.875	18.875	21.875
802.11ax HE80	42	5210	18.500	18.250	14.500	14.500	17.500

WLAN Tune-up Power (Laptop)							
WLAN 5.3GHz							
Mode	Channel	Frequency	SISO Ant 0 Max Tune up	SISO Ant 1 Max Tune up	MIMO Ant 0 Tune up	MIMO Ant 1 Tune up	MIMO Ant 0+1 Max Tune up
802.11a	52	5260	19.875	20.000			
	56	5280	20.000	20.000			
	60	5300	20.000	20.000			
	64	5320	20.000	20.000			
802.11n HT20	52	5260	19.750	20.000	18.000	18.000	21.000
	56	5280	20.000	20.000	18.000	18.000	21.000
	60	5300	20.000	20.000	18.000	18.000	21.000
	64	5320	20.000	20.000	18.000	18.000	21.000
802.11n HT40	54	5270	19.875	20.000	20.000	20.000	23.000
	62	5310	17.500	17.500	16.500	16.500	19.500
802.11ac VHT80	58	5290	17.500	17.500	14.250	14.250	17.250
802.11ac VHT160	50	5250	14.500	14.000	12.500	12.500	15.500
802.11ax HE20	52	5260	19.875	20.000	18.250	18.250	21.250
	56	5280	20.000	20.000	18.000	18.000	21.000
	60	5300	20.000	20.000	18.375	18.375	21.375
	64	5320	20.000	20.000	15.750	15.750	18.750
802.11ax HE40	54	5270	19.750	20.000	18.750	18.750	21.750
	62	5310	17.500	17.500	14.250	14.250	17.250
802.11ax HE80	58	5290	17.500	17.500	14.250	14.250	17.250
802.11ax HE160	50	5250	14.500	14.000	12.500	12.500	15.500

WLAN Tune-up Power (Laptop)							
WLAN 5.6GHz							
Mode	Channel	Frequency	SISO Ant 0 Max Tune up	SISO Ant 1 Max Tune up	MIMO Ant 0 Tune up	MIMO Ant 1 Tune up	MIMO Ant 0+1 Max Tune up
802.11a	100	5500	20.000	20.000			
	116	5580	20.000	20.000			
	120	5600	20.000	20.000			
	124	5620	20.000	20.000			
	132	5660	20.000	20.000			
	140	5700	20.000	20.000			
	144	5720	20.000	20.000			
802.11n HT20	100	5500	20.000	20.000	18.500	18.500	21.500
	116	5580	20.000	20.000	18.500	18.500	21.500
	120	5600	20.000	20.000	18.500	18.500	21.500
	124	5620	20.000	20.000	18.500	18.500	21.500
	132	5660	20.000	20.000	18.500	18.500	21.500
	140	5700	20.000	20.000	18.500	18.500	21.500
	144	5720	20.000	20.000	17.000	17.000	20.000
802.11n HT40	102	5510	19.750	20.000	18.000	18.000	21.000
	110	5550	20.000	20.000	18.000	18.000	21.000
	118	5590	20.000	20.000	18.000	18.000	21.000
	126	5630	20.000	20.000	18.000	18.000	21.000
	134	5670	20.000	20.000	19.500	19.500	22.500
	142	5710	20.000	20.000	17.000	17.000	20.000
802.11ac VHT80	106	5530	18.500	18.750	14.750	14.750	17.750
	122	5610	20.000	20.000	18.000	18.000	21.000
	138	5690	20.000	20.000	17.500	17.500	20.500
802.11ac VHT160	114	5570	15.500	15.500	14.000	14.000	17.000
802.11ax HE20	100	5500	20.000	20.000	18.500	18.500	21.500
	116	5580	20.000	20.000	18.500	18.500	21.500
	120	5600	20.000	20.000	18.500	18.500	21.500
	124	5620	20.000	20.000	18.500	18.500	21.500
	132	5660	20.000	20.000	18.500	18.500	21.500
	140	5700	20.000	20.000	18.500	18.500	21.500
	144	5720	20.000	20.000	17.000	17.000	20.000
802.11ax HE40	102	5510	19.750	20.000	18.000	18.000	21.000
	110	5550	20.000	20.000	18.000	18.000	21.000
	118	5590	20.000	20.000	18.000	18.000	21.000
	126	5630	20.000	20.000	18.000	18.000	21.000
	134	5670	20.000	20.000	19.500	19.500	22.500
	142	5710	20.000	20.000	17.000	17.000	20.000
802.11ax HE80	106	5530	18.500	18.750	14.750	14.750	17.750
	122	5610	20.000	20.000	18.000	18.000	21.000
	138	5690	20.000	20.000	17.500	17.500	20.500
802.11ax HE160	114	5570	15.500	15.500	14.000	14.000	17.000

WLAN Tune-up Power (Laptop)							
WLAN 5.8GHz							
Mode	Channel	Frequency	SISO Ant 0 Max Tune up	SISO Ant 1 Max Tune up	MIMO Ant 0 Tune up	MIMO Ant 1 Tune up	MIMO Ant 0+1 Max Tune up
802.11a	149	5745	20.000	20.000			
	153	5765	20.000	20.000			
	157	5785	20.000	20.000			
	161	5805	20.000	20.000			
	165	5825	20.000	20.000			
802.11n HT20	149	5745	20.000	20.000	20.000	20.000	23.000
	153	5765	20.000	20.000	20.000	20.000	23.000
	157	5785	20.000	20.000	20.000	20.000	23.000
	161	5805	20.000	20.000	20.000	20.000	23.000
	165	5825	20.000	20.000	20.000	20.000	23.000
802.11n HT40	151	5755	20.000	20.000	20.000	20.000	23.000
	159	5795	20.000	20.000	20.000	20.000	23.000
802.11ac VHT80	155	5775	20.000	20.000	15.750	15.750	18.750
802.11ax HE20	149	5745	20.000	20.000	18.125	18.125	21.125
	153	5765	20.000	20.000	18.125	18.125	21.125
	157	5785	20.000	20.000	18.125	18.125	21.125
	161	5805	20.000	20.000	18.125	18.125	21.125
	165	5825	20.000	20.000	18.250	18.250	21.250
802.11ax HE40	151	5755	20.000	20.000	18.625	18.625	21.625
	159	5795	20.000	20.000	18.625	18.625	21.625
802.11ax HE80	155	5775	20.000	20.000	15.750	15.750	18.750

**WLAN Tune-up Power (Laptop)**

**UNII-5**

Mode	Channel	Frequency	SISO Ant 0 Max Tune up	SISO Ant 1 Max Tune up	MIMO Ant 0 Tune up	MIMO Ant 1 Tune up	MIMO Ant 0+1 Max Tune up
802.11ax HE20	1	5955	5.00	5.00	2.00	2.00	5.00
	5	5975	5.00	5.00	2.00	2.00	5.00
	9	5995	5.00	5.00	2.00	2.00	5.00
	13	6015	5.00	5.00	2.00	2.00	5.00
	17	6035	5.00	5.00	2.00	2.00	5.00
	21	6055	5.00	5.00	2.00	2.00	5.00
	25	6075	5.00	5.00	2.00	2.00	5.00
	29	6095	5.00	5.00	2.00	2.00	5.00
	33	6115	5.00	5.00	2.00	2.00	5.00
	37	6135	5.00	5.00	2.00	2.00	5.00
	41	6155	5.00	5.00	2.00	2.00	5.00
	45	6175	5.00	5.00	2.00	2.00	5.00
	49	6195	5.00	5.00	2.00	2.00	5.00
	53	6215	5.00	5.00	2.00	2.00	5.00
	57	6235	5.00	5.00	2.00	2.00	5.00
	61	6255	5.00	5.00	2.00	2.00	5.00
	65	6275	5.00	5.00	2.00	2.00	5.00
	69	6295	5.00	5.00	2.00	2.00	5.00
	73	6315	5.00	5.00	2.00	2.00	5.00
	77	6335	5.00	5.00	2.00	2.00	5.00
81	6355	5.00	5.00	2.00	2.00	5.00	
85	6375	5.00	5.00	2.00	2.00	5.00	
89	6395	5.00	5.00	2.00	2.00	5.00	
93	6415	5.00	5.00	2.00	2.00	5.00	
802.11ax HE40	3	5965	8.25	8.25	5.25	5.25	8.25
	11	6005	8.25	8.25	5.25	5.25	8.25
	19	6045	8.25	8.25	5.25	5.25	8.25
	27	6085	8.25	8.25	5.25	5.25	8.25
	35	6125	8.25	8.25	5.25	5.25	8.25
	43	6165	8.25	8.25	5.25	5.25	8.25
	51	6205	8.25	8.25	5.25	5.25	8.25
	59	6245	8.25	8.25	5.25	5.25	8.25
	67	6285	8.25	8.25	5.25	5.25	8.25
	75	6325	8.25	8.25	5.25	5.25	8.25
	83	6365	8.25	8.25	5.25	5.25	8.25
91	6405	8.25	8.25	5.25	5.25	8.25	
802.11ax HE80	7	5985	10.75	10.75	7.75	7.75	10.75
	23	6065	10.75	10.75	7.75	7.75	10.75
	39	6145	10.75	10.75	7.75	7.75	10.75
	55	6225	10.75	10.75	7.75	7.75	10.75
	71	6305	10.75	10.75	7.75	7.75	10.75
	87	6385	10.75	10.75	7.75	7.75	10.75
802.11ax HE160	15	6025	13.00	13.00	10.50	10.50	13.50
	47	6185	13.00	13.00	10.50	10.50	13.50
	79	6345	13.00	13.00	10.50	10.50	13.50

**WLAN Tune-up Power (Laptop)**

**UNII-6**

Mode	Channel	Frequency	SISO Ant 0 Max Tune up	SISO Ant 1 Max Tune up	MIMO Ant 0 Tune up	MIMO Ant 1 Tune up	MIMO Ant 0+1 Max Tune up
802.11ax HE20	97	6435	5.00	5.00	2.00	2.00	5.00
	101	6455	5.00	5.00	2.00	2.00	5.00
	105	6475	5.00	5.00	2.00	2.00	5.00
	109	6495	5.00	5.00	2.00	2.00	5.00
	113	6515	5.00	5.00	2.00	2.00	5.00
	117	6535	4.25	4.25	1.25	1.25	4.25
802.11ax HE40	99	6445	8.25	8.25	5.25	5.25	8.25
	107	6485	8.25	8.25	5.25	5.25	8.25
	115	6525	8.25	8.25	5.25	5.25	8.25
802.11ax HE80	103	6465	10.75	10.75	7.75	7.75	10.75
	119	6545	10.75	10.75	7.75	7.75	10.75
802.11ax HE160	111	6505	13.00	13.00	10.50	10.50	13.50

**WLAN Tune-up Power (Laptop)**

**UNII-7**

Mode	Channel	Frequency	SISO Ant 0 Max Tune up	SISO Ant 1 Max Tune up	MIMO Ant 0 Tune up	MIMO Ant 1 Tune up	MIMO Ant 0+1 Max Tune up
802.11ax HE20	121	6555	4.25	4.25	1.25	1.25	4.25
	125	6575	4.25	4.25	1.25	1.25	4.25
	129	6595	4.25	4.25	1.25	1.25	4.25
	133	6615	4.25	4.25	1.25	1.25	4.25
	137	6635	4.25	4.25	1.25	1.25	4.25
	141	6655	4.25	4.25	1.25	1.25	4.25
	145	6675	4.25	4.25	1.25	1.25	4.25
	149	6695	4.25	4.25	1.25	1.25	4.25
	153	6715	4.25	4.25	1.25	1.25	4.25
	157	6735	4.25	4.25	1.25	1.25	4.25
	161	6755	4.25	4.25	1.25	1.25	4.25
	165	6775	4.25	4.25	1.25	1.25	4.25
	169	6795	4.25	4.25	1.25	1.25	4.25
	173	6815	4.25	4.25	1.25	1.25	4.25
	177	6835	4.25	4.25	1.25	1.25	4.25
	181	6855	4.25	4.25	1.25	1.25	4.25
185	6875	4.25	4.25	1.25	1.25	4.25	
802.11ax HE40	123	6565	7.50	7.50	4.50	4.50	7.50
	131	6605	7.50	7.50	4.50	4.50	7.50
	139	6645	7.50	7.50	4.50	4.50	7.50
	147	6685	7.50	7.50	4.50	4.50	7.50
	155	6725	7.50	7.50	4.50	4.50	7.50
	163	6765	7.50	7.50	4.50	4.50	7.50
	171	6805	7.50	7.50	4.50	4.50	7.50
	179	6845	7.50	7.50	4.50	4.50	7.50
187	6885	7.50	7.50	4.50	4.50	7.50	
802.11ax HE80	135	6625	10.00	10.00	7.00	7.00	10.00
	151	6705	10.00	10.00	7.00	7.00	10.00
	167	6785	10.00	10.00	7.00	7.00	10.00
	183	6865	10.00	10.00	7.00	7.00	10.00
802.11ax HE160	143	6665	12.75	12.75	9.75	9.75	12.75
	175	6825	12.75	12.75	9.75	9.75	12.75

WLAN Tune-up Power (Laptop)							
UNII-8							
Mode	Channel	Frequency	SISO Ant 0 Max Tune up	SISO Ant 1 Max Tune up	MIMO Ant 0 Tune up	MIMO Ant 1 Tune up	MIMO Ant 0+1 Max Tune up
802.11ax HE20	189	6895	4.25	4.25	1.25	1.25	4.25
	193	6915	4.25	4.25	1.25	1.25	4.25
	197	6935	4.25	4.25	1.25	1.25	4.25
	201	6955	4.25	4.25	1.25	1.25	4.25
	205	6975	4.25	4.25	1.25	1.25	4.25
	209	6995	4.25	4.25	1.25	1.25	4.25
	213	7015	4.25	4.25	1.25	1.25	4.25
	217	7035	4.25	4.25	1.25	1.25	4.25
	221	7055	4.25	4.25	1.25	1.25	4.25
	225	7075	4.25	4.25	1.25	1.25	4.25
	229	7095	4.25	4.25	1.25	1.25	4.25
	233	7115	-1.00	-1.00	-4.00	-4.00	-1.00
802.11ax HE40	195	6925	7.50	7.50	4.50	4.50	7.50
	203	6965	7.50	7.50	4.50	4.50	7.50
	211	7005	7.50	7.50	4.50	4.50	7.50
	219	7045	7.50	7.50	4.50	4.50	7.50
	227	7085	7.50	7.50	4.50	4.50	7.50
802.11ax HE80	199	6945	10.00	10.00	7.00	7.00	10.00
	215	7025	10.00	10.00	7.00	7.00	10.00
802.11ax HE160	207	6985	12.75	12.75	9.75	9.75	12.75



## **Annex E. Measured Conducted Power Result**

The measuring conducted power (Unit: dBm) are shown as below.

### WCDMA Conducted Power (Full)

Band	WCDMA II			WCDMA IV			WCDMA V		
TX Channel	9262	9400	9538	1312	1413	1513	4132	4182	4233
Rx Channel	9662	9800	9938	1537	1638	1738	4357	4407	4458
Frequency	1852.4	1880	1907.6	1712.4	1732.6	1752.6	826.4	836.4	846.6
RMC 12.2K	23.83	23.89	23.85	24.11	24.05	24.03	23.66	23.58	23.55
HSDPA Subtest-1	22.76	22.82	22.79	23.11	22.97	22.92	22.68	22.58	22.55
HSDPA Subtest-2	22.75	22.79	22.72	23.08	22.95	22.91	22.66	22.56	22.53
HSDPA Subtest-3	22.32	22.33	22.28	22.65	22.51	22.46	22.18	22.12	22.11
HSDPA Subtest-4	22.26	22.29	22.26	22.62	22.45	22.41	22.15	22.07	22.05
DC-HSDPA Subtest-1	22.54	22.61	22.54	22.84	22.72	22.65	22.58	22.53	22.52
DC-HSDPA Subtest-2	22.53	22.52	22.52	22.86	22.65	22.63	22.55	22.52	22.51
DC-HSDPA Subtest-3	22.03	22.08	22.05	22.41	22.31	22.24	22.08	22.05	22.03
DC-HSDPA Subtest-4	22.01	22.05	22.03	22.40	22.16	22.19	22.05	22.03	22.02
HSUPA Subtest-1	22.51	22.53	22.52	22.51	22.53	22.52	22.54	22.51	22.53
HSUPA Subtest-2	20.75	20.77	20.75	21.06	20.91	20.89	20.61	20.55	20.53
HSUPA Subtest-3	21.77	21.81	21.72	22.07	21.95	21.95	21.65	21.58	21.56
HSUPA Subtest-4	20.55	20.56	20.52	20.75	20.61	20.62	20.55	20.56	20.53
HSUPA Subtest-5	22.50	22.50	22.60	22.60	22.60	22.60	22.50	22.60	22.60

LTE Conducted Power (Full)							
LTE Band 2							
BW	MCS Index	RB Size	RB Offset	Low	Mid	High	3GPP MPR (dB)
		Channel		18700	18900	19100	
		Frequency (MHz)		1860	1880	1900	
20M	QPSK	1	0	23.32	23.13	23.16	0
		1	50	23.27	22.98	22.95	0
		1	99	22.81	22.95	22.92	0
		50	0	22.32	22.31	22.25	1
		50	25	22.10	22.24	22.19	1
		50	50	22.14	22.23	22.17	1
		100	0	22.19	22.23	22.22	1
20M	16QAM	1	0	22.02	22.08	22.03	1
		1	50	21.85	21.94	21.92	1
		1	99	21.86	21.88	21.86	1
		50	0	21.11	21.23	21.16	2
		50	25	21.14	21.21	21.15	2
		50	50	21.08	21.19	21.15	2
		100	0	21.14	21.18	21.18	2
20M	64QAM	1	0	20.68	20.81	20.73	2
		1	50	20.88	20.89	20.88	2
		1	99	20.75	20.77	20.76	2
		50	0	20.07	20.16	20.11	3
		50	25	20.15	20.25	20.25	3
		50	50	20.17	20.29	20.25	3
		100	0	20.04	20.18	20.10	3
20M	256QAM	1	0	18.23	18.26	18.20	5
		1	50	18.16	18.22	18.11	5
		1	99	18.19	18.21	18.13	5
		50	0	18.10	18.11	18.04	5
		50	25	18.14	18.17	18.11	5
		50	50	18.17	18.19	18.10	5
		100	0	18.10	18.13	18.09	5
BW	MCS Index	Channel		18675	18900	19125	3GPP MPR
Frequency (MHz)		1857.5	1880	1902.5			
15M	QPSK	1	0	23.16	23.18	23.12	0
		1	37	22.76	22.89	22.81	0
		1	74	22.75	22.89	22.88	0
		36	0	22.11	22.25	22.24	1
		36	19	22.09	22.16	22.15	1
		36	39	22.07	22.17	22.15	1
		75	0	22.12	22.23	22.19	1
15M	16QAM	1	0	21.94	22.06	22.01	1
		1	37	21.79	21.92	21.89	1
		1	74	21.85	21.87	21.79	1
		36	0	21.07	21.17	21.14	2
		36	19	21.11	21.17	21.09	2
		36	39	20.99	21.17	21.06	2
		75	0	21.11	21.08	21.13	2
15M	64QAM	1	0	20.59	20.80	20.67	2
		1	37	20.85	20.80	20.83	2
		1	74	20.66	20.72	20.76	2
		36	0	19.97	20.11	20.03	3
		36	19	20.11	20.17	20.19	3
		36	39	20.13	20.26	20.25	3
		75	0	19.95	20.12	20.09	3
15M	256QAM	1	0	18.21	18.16	18.14	5
		1	37	18.06	18.17	18.07	5
		1	74	18.09	18.15	18.10	5
		36	0	18.08	18.11	18.03	5
		36	19	18.07	18.10	18.07	5
		36	39	18.12	18.11	18.06	5
		75	0	18.02	18.08	18.00	5

LTE Conducted Power (Full)							
LTE Band 2							
BW	MCS Index	Channel		18650	18900	19150	3GPP MPR
		Frequency (MHz)		1855	1880	1905	
10M	QPSK	1	0	23.09	23.04	23.02	0
		1	24	22.66	22.88	22.74	0
		1	49	22.75	22.78	22.86	0
		25	0	21.99	22.24	22.09	1
		25	12	22.00	22.06	22.14	1
		25	25	22.02	22.02	22.02	1
		50	0	22.06	22.12	22.06	1
10M	16QAM	1	0	21.81	21.94	21.95	1
		1	24	21.67	21.80	21.84	1
		1	49	21.79	21.86	21.70	1
		25	0	21.00	21.06	21.02	2
		25	12	20.98	21.16	20.95	2
		25	25	20.99	21.11	20.97	2
		50	0	20.98	21.08	20.98	2
10M	64QAM	1	0	20.53	20.67	20.55	2
		1	24	20.85	20.80	20.70	2
		1	49	20.59	20.64	20.73	2
		25	0	19.92	20.10	19.89	3
		25	12	20.07	20.08	20.14	3
		25	25	20.07	20.14	20.24	3
		50	0	19.91	20.07	20.08	3
10M	256QAM	1	0	18.13	18.12	18.06	5
		1	24	17.94	18.18	17.93	5
		1	49	18.01	18.07	17.93	5
		25	0	18.10	18.04	17.90	5
		25	12	18.00	18.07	18.00	5
		25	25	18.02	18.18	17.94	5
		50	0	18.05	18.12	18.08	5
BW	MCS Index	Channel		18625	18900	19175	3GPP MPR
		Frequency (MHz)		1852.5	1880	1907.5	
5M	QPSK	1	0	23.11	23.07	23.01	0
		1	12	22.74	22.86	22.62	0
		1	24	22.70	22.81	22.72	0
		12	0	21.98	22.12	22.07	1
		12	6	21.98	22.09	22.07	1
		12	13	21.99	22.11	22.02	1
		25	0	22.00	22.13	21.97	1
5M	16QAM	1	0	21.90	22.02	21.99	1
		1	12	21.66	21.83	21.80	1
		1	24	21.82	21.87	21.68	1
		12	0	20.94	21.16	21.06	2
		12	6	20.99	21.04	20.94	2
		12	13	20.90	21.16	21.04	2
		25	0	20.96	21.00	21.13	2
5M	64QAM	1	0	20.49	20.80	20.61	2
		1	12	20.73	20.76	20.79	2
		1	24	20.60	20.67	20.71	2
		12	0	19.94	19.97	19.95	3
		12	6	20.06	20.11	20.07	3
		12	13	20.01	20.15	20.20	3
		25	0	19.89	20.11	20.04	3
5M	256QAM	1	0	18.09	18.13	17.96	5
		1	12	18.09	18.02	17.87	5
		1	24	18.01	18.16	17.87	5
		12	0	18.06	18.09	17.82	5
		12	6	17.97	18.04	17.99	5
		12	13	18.00	18.13	17.87	5
		25	0	18.02	17.98	17.99	5

LTE Conducted Power (Full)							
LTE Band 2							
BW	MCS Index	Channel		18615	18900	19185	3GPP MPR
		Frequency (MHz)		1851.5	1880	1908.5	
3M	QPSK	1	0	23.07	23.15	23.06	0
		1	7	22.75	22.89	22.75	0
		1	14	22.68	22.74	22.79	0
		8	0	22.05	22.24	22.14	1
		8	3	22.04	22.12	22.09	1
		8	7	21.99	22.05	22.09	1
		15	0	22.11	22.12	22.04	1
3M	16QAM	1	0	21.88	22.02	21.86	1
		1	7	21.65	21.82	21.76	1
		1	14	21.85	21.75	21.73	1
		8	0	21.07	21.05	20.99	2
		8	3	21.09	21.06	20.96	2
		8	7	20.94	21.05	21.03	2
		15	0	21.07	21.03	20.98	2
3M	64QAM	1	0	20.58	20.68	20.64	2
		1	7	20.70	20.80	20.79	2
		1	14	20.62	20.68	20.62	2
		8	0	19.93	20.03	19.97	3
		8	3	20.04	20.13	20.12	3
		8	7	20.12	20.22	20.17	3
		15	0	19.92	20.05	19.96	3
3M	256QAM	1	0	18.07	18.09	18.16	5
		1	7	17.95	18.05	17.97	5
		1	14	18.04	18.07	18.09	5
		8	0	17.98	17.95	17.86	5
		8	3	18.03	18.04	17.99	5
		8	7	18.14	18.09	17.89	5
		15	0	18.02	18.07	17.88	5
BW	MCS Index	Channel		18607	18900	19193	3GPP MPR
		Frequency (MHz)		1850.7	1880	1909.3	
1.4M	QPSK	1	0	23.15	23.15	23.03	0
		1	2	22.66	22.92	22.75	0
		1	5	22.71	22.85	22.80	0
		3	0	23.05	22.95	23.01	0
		3	1	22.97	22.93	22.94	0
		3	3	22.91	22.97	22.99	0
		6	0	22.01	22.17	22.09	1
1.4M	16QAM	1	0	21.86	21.97	21.88	1
		1	2	21.76	21.86	21.85	1
		1	5	21.68	21.82	21.75	1
		3	0	21.97	22.16	22.00	1
		3	1	22.05	22.09	22.04	1
		3	3	21.87	22.02	22.04	1
		6	0	21.14	20.98	21.12	2
1.4M	64QAM	1	0	20.51	20.64	20.50	2
		1	2	20.78	20.75	20.72	2
		1	5	20.60	20.76	20.72	2
		3	0	20.97	21.06	21.05	2
		3	1	20.92	21.19	21.03	2
		3	3	21.09	21.22	21.08	2
		6	0	19.91	20.02	19.93	3
1.4M	256QAM	1	0	18.01	18.08	17.97	5
		1	2	18.12	18.09	17.91	5
		1	5	18.15	18.07	17.97	5
		3	0	18.06	17.95	17.80	5
		3	1	17.96	18.04	17.99	5
		3	3	17.93	18.05	18.02	5
		6	0	17.95	18.00	18.01	5

LTE Conducted Power (Full)							
LTE Band 4							
BW	MCS Index	RB Size	RB Offset	Low	Mid	High	3GPP MPR (dB)
		Channel		20050	20175	20300	
		Frequency (MHz)		1720	1732.5	1745	
20M	QPSK	1	0	23.27	23.25	23.22	0
		1	50	23.21	23.18	23.15	0
		1	99	22.85	22.77	22.77	0
		50	0	22.35	22.32	22.26	1
		50	25	22.32	22.28	22.26	1
		50	50	22.29	22.25	22.15	1
		100	0	22.31	22.29	22.19	1
20M	16QAM	1	0	22.57	22.57	22.53	1
		1	50	22.53	22.43	22.35	1
		1	99	22.48	22.39	22.31	1
		50	0	21.17	21.08	20.98	2
		50	25	21.27	21.18	21.11	2
		50	50	21.32	21.22	21.16	2
		100	0	21.26	21.26	21.16	2
20M	64QAM	1	0	21.38	21.28	21.19	2
		1	50	21.42	21.34	21.26	2
		1	99	21.33	21.23	21.15	2
		50	0	20.15	20.08	20.02	3
		50	25	20.27	20.26	20.21	3
		50	50	20.25	20.19	20.15	3
		100	0	20.21	20.19	20.09	3
20M	256QAM	1	0	18.33	18.25	18.15	5
		1	50	18.28	18.27	18.24	5
		1	99	18.26	18.19	18.15	5
		50	0	18.08	18.01	17.96	5
		50	25	18.23	18.21	18.11	5
		50	50	18.26	18.22	18.15	5
		100	0	18.17	18.13	18.10	5
BW	MCS Index	Channel		20025	20175	20325	3GPP MPR
Frequency (MHz)		1717.5	1732.5	1747.5			
15M	QPSK	1	0	23.12	23.06	23.01	0
		1	37	22.88	22.77	22.81	0
		1	74	22.75	22.76	22.74	0
		36	0	22.25	22.28	22.22	1
		36	19	22.23	22.18	22.22	1
		36	39	22.24	22.18	22.05	1
		75	0	22.31	22.27	22.18	1
15M	16QAM	1	0	22.48	22.50	22.46	1
		1	37	22.48	22.33	22.30	1
		1	74	22.41	22.34	22.28	1
		36	0	21.14	20.99	20.89	2
		36	19	21.23	21.13	21.02	2
		36	39	21.23	21.21	21.11	2
		75	0	21.26	21.23	21.12	2
15M	64QAM	1	0	21.35	21.21	21.17	2
		1	37	21.38	21.26	21.18	2
		1	74	21.33	21.18	21.05	2
		36	0	20.14	20.03	19.99	3
		36	19	20.26	20.19	20.15	3
		36	39	20.25	20.14	20.11	3
		75	0	20.11	20.10	20.00	3
15M	256QAM	1	0	18.24	18.19	18.15	5
		1	37	18.24	18.21	18.15	5
		1	74	18.16	18.11	18.05	5
		36	0	18.05	17.95	17.86	5
		36	19	18.22	18.18	18.06	5
		36	39	18.25	18.16	18.05	5
		75	0	18.17	18.12	18.04	5

LTE Conducted Power (Full)							
LTE Band 4							
BW	MCS Index	Channel		20000	20175	20350	3GPP MPR
		Frequency (MHz)		1715	1732.5	1750	
10M	QPSK	1	0	23.11	23.00	22.89	0
		1	24	22.79	22.70	22.74	0
		1	49	22.61	22.66	22.68	0
		25	0	22.16	22.15	22.17	1
		25	12	22.23	22.11	22.13	1
		25	25	22.24	22.17	22.02	1
		50	0	22.21	22.15	22.03	1
10M	16QAM	1	0	22.47	22.45	22.41	1
		1	24	22.46	22.28	22.27	1
		1	49	22.39	22.26	22.23	1
		25	0	21.06	20.90	20.76	2
		25	12	21.16	21.12	20.96	2
		25	25	21.21	21.14	21.00	2
		50	0	21.26	21.09	21.04	2
10M	64QAM	1	0	21.20	21.14	21.07	2
		1	24	21.29	21.19	21.12	2
		1	49	21.27	21.18	20.91	2
		25	0	20.12	19.91	19.99	3
		25	12	20.24	20.15	20.10	3
		25	25	20.25	20.08	20.11	3
		50	0	20.03	19.98	19.92	3
10M	256QAM	1	0	18.25	18.05	18.08	5
		1	24	18.20	18.06	18.05	5
		1	49	18.07	18.02	18.10	5
		25	0	17.86	17.90	17.92	5
		25	12	18.06	18.12	18.10	5
		25	25	18.12	18.11	17.96	5
		50	0	17.97	17.93	17.98	5
BW	MCS Index	Channel		19975	20175	20375	3GPP MPR
		Frequency (MHz)		1712.5	1732.5	1752.5	
5M	QPSK	1	0	23.05	22.95	22.85	0
		1	12	22.79	22.69	22.69	0
		1	24	22.65	22.63	22.63	0
		12	0	22.16	22.24	22.17	1
		12	6	22.10	22.11	22.08	1
		12	13	22.24	22.03	21.88	1
		25	0	22.19	22.19	21.99	1
5M	16QAM	1	0	22.41	22.44	22.31	1
		1	12	22.47	22.23	22.28	1
		1	24	22.41	22.24	22.18	1
		12	0	21.13	20.90	20.86	2
		12	6	21.10	21.03	20.93	2
		12	13	21.09	21.10	21.09	2
		25	0	21.14	21.11	21.11	2
5M	64QAM	1	0	21.29	21.17	21.05	2
		1	12	21.29	21.20	21.11	2
		1	24	21.25	21.14	21.05	2
		12	0	20.13	19.92	19.92	3
		12	6	20.22	20.08	20.15	3
		12	13	20.21	20.03	20.01	3
		25	0	20.10	20.03	19.85	3
5M	256QAM	1	0	18.14	18.07	17.97	5
		1	12	18.24	18.16	17.89	5
		1	24	18.13	18.16	17.89	5
		12	0	17.88	17.98	17.70	5
		12	6	18.02	17.99	17.97	5
		12	13	18.02	18.14	18.04	5
		25	0	18.02	18.05	17.94	5

LTE Conducted Power (Full)							
LTE Band 4							
BW	MCS Index	Channel		19965	20175	20385	3GPP MPR
		Frequency (MHz)		1711.5	1732.5	1753.5	
3M	QPSK	1	0	23.05	23.03	22.93	0
		1	7	22.87	22.63	22.73	0
		1	14	22.60	22.69	22.64	0
		8	0	22.17	22.21	22.11	1
		8	3	22.15	22.10	22.12	1
		8	7	22.24	22.07	21.99	1
		15	0	22.25	22.20	22.07	1
3M	16QAM	1	0	22.38	22.38	22.45	1
		1	7	22.47	22.23	22.16	1
		1	14	22.30	22.34	22.15	1
		8	0	21.08	20.88	20.82	2
		8	3	21.15	20.99	20.92	2
		8	7	21.10	21.15	21.05	2
		15	0	21.17	21.15	21.00	2
3M	64QAM	1	0	21.35	21.15	21.05	2
		1	7	21.32	21.21	21.06	2
		1	14	21.27	21.17	20.95	2
		8	0	19.99	19.97	19.94	3
		8	3	20.14	20.14	20.07	3
		8	7	20.24	20.13	20.08	3
		15	0	20.05	20.07	19.92	3
3M	256QAM	1	0	18.13	18.08	18.04	5
		1	7	18.20	18.19	18.11	5
		1	14	18.19	18.11	18.09	5
		8	0	18.02	17.98	17.77	5
		8	3	18.05	18.07	18.01	5
		8	7	18.18	18.05	18.07	5
		15	0	18.17	18.01	17.99	5
BW	MCS Index	Channel		19957	20175	20393	3GPP MPR
		Frequency (MHz)		1710.7	1732.5	1754.3	
1.4M	QPSK	1	0	23.01	23.04	23.03	0
		1	2	22.81	22.71	22.75	0
		1	5	22.76	22.60	22.69	0
		3	0	23.06	23.00	23.06	0
		3	1	23.07	23.02	23.14	0
		3	3	23.05	23.11	22.82	0
		6	0	22.18	22.24	22.12	1
1.4M	16QAM	1	0	22.51	22.46	22.31	1
		1	2	22.38	22.30	22.30	1
		1	5	22.37	22.33	22.22	1
		3	0	22.03	22.01	21.88	1
		3	1	22.18	22.08	21.89	1
		3	3	22.19	22.08	22.01	1
		6	0	21.08	21.15	20.99	2
1.4M	64QAM	1	0	21.22	21.23	21.09	2
		1	2	21.35	21.12	21.02	2
		1	5	21.20	21.10	20.96	2
		3	0	20.93	21.02	20.92	2
		3	1	21.20	21.15	21.05	2
		3	3	21.04	21.17	21.07	2
		6	0	20.16	20.06	20.02	3
1.4M	256QAM	1	0	18.27	18.11	17.91	5
		1	2	18.03	18.13	18.21	5
		1	5	18.10	18.13	18.08	5
		3	0	17.98	17.91	17.83	5
		3	1	18.13	18.11	17.93	5
		3	3	18.18	18.21	18.09	5
		6	0	18.06	17.96	18.05	5



LTE Conducted Power (Full)							
LTE Band 5							
BW	MCS Index	RB Size	RB Offset	Low	Mid	High	3GPP MPR (dB)
		Channel		20450	20525	20600	
		Frequency (MHz)		829	836.5	844	
10M	QPSK	1	0	23.09	23.22	23.17	0
		1	24	23.05	23.21	23.11	0
		1	49	22.95	23.01	22.93	0
		25	0	22.08	22.21	22.15	1
		25	12	22.06	22.18	22.10	1
		25	25	22.05	22.16	22.05	1
		50	0	22.10	22.19	22.12	1
10M	16QAM	1	0	22.40	22.58	22.48	1
		1	24	22.36	22.49	22.39	1
		1	49	22.44	22.51	22.49	1
		25	0	21.09	21.23	21.15	2
		25	12	21.13	21.21	21.18	2
		25	25	21.15	21.25	21.21	2
		50	0	21.04	21.19	21.09	2
10M	64QAM	1	0	21.42	21.44	21.43	2
		1	24	21.29	21.38	21.32	2
		1	49	21.20	21.33	21.28	2
		25	0	20.06	20.22	20.14	3
		25	12	20.07	20.15	20.10	3
		25	25	20.09	20.19	20.14	3
		50	0	20.11	20.17	20.13	3
10M	256QAM	1	0	18.17	18.33	18.24	5
		1	24	18.21	18.27	18.23	5
		1	49	18.15	18.26	18.21	5
		25	0	18.01	18.16	18.04	5
		25	12	17.98	18.15	18.04	5
		25	25	18.03	18.13	18.12	5
		50	0	18.06	18.18	18.12	5
BW	MCS Index	Channel		20425	20525	20625	3GPP MPR
Frequency (MHz)		826.5	836.5	846.5			
5M	QPSK	1	0	23.09	23.21	23.10	0
		1	12	23.05	23.17	23.02	0
		1	24	22.88	22.95	22.85	0
		12	0	22.00	22.12	22.12	1
		12	6	22.04	22.09	22.01	1
		12	13	22.02	22.14	22.00	1
		25	0	22.07	22.15	22.06	1
5M	16QAM	1	0	22.32	22.49	22.40	1
		1	12	22.32	22.42	22.33	1
		1	24	22.35	22.45	22.45	1
		12	0	21.05	21.16	21.14	2
		12	6	21.08	21.12	21.13	2
		12	13	21.08	21.21	21.20	2
		25	0	20.99	21.09	21.02	2
5M	64QAM	1	0	21.32	21.38	21.43	2
		1	12	21.21	21.35	21.22	2
		1	24	21.12	21.23	21.23	2
		12	0	20.00	20.20	20.08	3
		12	6	20.00	20.08	20.05	3
		12	13	20.07	20.14	20.04	3
		25	0	20.01	20.10	20.09	3
5M	256QAM	1	0	18.07	18.28	18.24	5
		1	12	18.18	18.19	18.14	5
		1	24	18.09	18.18	18.15	5
		12	0	17.99	18.12	18.02	5
		12	6	17.90	18.14	17.94	5
		12	13	18.02	18.06	18.09	5
		25	0	18.03	18.15	18.05	5

LTE Conducted Power (Full)							
LTE Band 5							
BW	MCS Index	Channel		20415	20525	20635	3GPP MPR
		Frequency (MHz)		825.5	836.5	847.5	
3M	QPSK	1	0	23.01	23.14	23.03	0
		1	7	22.98	23.15	22.90	0
		1	14	22.84	22.83	22.72	0
		8	0	21.96	22.03	21.97	1
		8	3	21.97	21.95	21.89	1
		8	7	21.91	22.08	21.87	1
		15	0	21.99	22.09	21.93	1
3M	16QAM	1	0	22.30	22.46	22.30	1
		1	7	22.31	22.34	22.30	1
		1	14	22.26	22.31	22.38	1
		8	0	20.93	21.12	21.08	2
		8	3	21.00	20.97	21.04	2
		8	7	20.95	21.14	21.19	2
		15	0	20.93	20.95	20.87	2
3M	64QAM	1	0	21.18	21.24	21.38	2
		1	7	21.13	21.24	21.11	2
		1	14	21.07	21.18	21.15	2
		8	0	19.91	20.13	19.98	3
		8	3	19.96	19.94	19.94	3
		8	7	19.99	20.04	20.02	3
		15	0	19.90	20.04	20.06	3
3M	256QAM	1	0	18.09	18.14	18.11	5
		1	7	18.00	18.17	18.01	5
		1	14	17.97	18.19	18.07	5
		8	0	17.93	17.98	17.99	5
		8	3	17.92	17.94	17.99	5
		8	7	17.95	17.93	17.97	5
		15	0	17.95	17.99	18.07	5
BW	MCS Index	Channel		20407	20525	20643	3GPP MPR
		Frequency (MHz)		824.7	836.5	848.3	
1.4M	QPSK	1	0	22.88	22.99	23.02	0
		1	2	22.83	23.10	22.92	0
		1	5	22.86	22.84	22.77	0
		3	0	22.80	22.93	22.89	0
		3	1	22.90	22.96	22.96	0
		3	3	22.84	23.03	22.93	0
		6	0	21.98	22.18	22.02	1
1.4M	16QAM	1	0	22.39	22.38	22.30	1
		1	2	22.24	22.41	22.27	1
		1	5	22.36	22.41	22.44	1
		3	0	22.07	21.98	22.02	1
		3	1	22.10	22.12	22.07	1
		3	3	21.98	22.18	22.02	1
		6	0	20.82	21.07	20.91	2
1.4M	64QAM	1	0	21.35	21.27	21.31	2
		1	2	21.18	21.31	21.21	2
		1	5	21.02	21.18	21.09	2
		3	0	20.87	21.19	20.97	2
		3	1	21.01	20.94	21.05	2
		3	3	21.00	21.08	20.96	2
		6	0	19.94	20.08	20.10	3
1.4M	256QAM	1	0	18.03	18.24	18.01	5
		1	2	18.14	18.19	17.96	5
		1	5	17.96	18.14	17.92	5
		3	0	17.79	18.08	17.83	5
		3	1	17.87	18.08	17.83	5
		3	3	17.84	18.07	17.95	5
		6	0	17.82	18.07	18.00	5

LTE Conducted Power (Full)							
LTE Band 7							
BW	MCS Index	RB Size	RB Offset	Low	Mid	High	3GPP MPR (dB)
		Channel		20850	21100	21350	
		Frequency (MHz)		2510	2535	2560	
20M	QPSK	1	0	23.01	23.08	23.19	0
		1	50	22.99	23.06	23.15	0
		1	99	22.98	23.01	23.05	0
		50	0	22.35	22.42	22.48	1
		50	25	22.22	22.27	22.35	1
		50	50	22.18	22.18	22.25	1
		100	0	22.21	22.23	22.31	1
20M	16QAM	1	0	22.51	22.54	22.55	1
		1	50	22.34	22.37	22.39	1
		1	99	21.88	21.92	22.02	1
		50	0	21.42	21.42	21.42	2
		50	25	21.26	21.36	21.46	2
		50	50	21.08	21.16	21.23	2
		100	0	21.12	21.12	21.16	2
20M	64QAM	1	0	21.23	21.29	21.35	2
		1	50	21.38	21.42	21.46	2
		1	99	21.20	21.28	21.32	2
		50	0	20.18	20.26	20.33	3
		50	25	20.26	20.30	20.34	3
		50	50	20.18	20.18	20.22	3
		100	0	20.20	20.20	20.26	3
20M	256QAM	1	0	18.13	18.19	18.26	5
		1	50	18.23	18.30	18.32	5
		1	99	18.17	18.19	18.26	5
		50	0	18.22	18.26	18.29	5
		50	25	18.14	18.23	18.22	5
		50	50	18.17	18.22	18.23	5
		100	0	18.15	18.25	18.26	5
BW	MCS Index	Channel		20825	21100	21375	3GPP MPR
Frequency (MHz)		2507.5	2535	2562.5			
15M	QPSK	1	0	22.96	23.08	23.15	0
		1	37	22.91	23.01	23.13	0
		1	74	22.94	22.95	23.05	0
		36	0	22.27	22.36	22.46	1
		36	19	22.22	22.17	22.35	1
		36	39	22.09	22.13	22.23	1
		75	0	22.21	22.21	22.24	1
15M	16QAM	1	0	22.51	22.49	22.46	1
		1	37	22.27	22.35	22.35	1
		1	74	21.83	21.84	21.93	1
		36	0	21.32	21.35	21.37	2
		36	19	21.16	21.27	21.40	2
		36	39	21.06	21.15	21.23	2
		75	0	21.12	21.08	21.12	2
15M	64QAM	1	0	21.15	21.20	21.29	2
		1	37	21.34	21.39	21.38	2
		1	74	21.12	21.20	21.32	2
		36	0	20.12	20.18	20.28	3
		36	19	20.25	20.28	20.27	3
		36	39	20.15	20.12	20.18	3
		75	0	20.13	20.18	20.25	3
15M	256QAM	1	0	18.06	18.11	18.19	5
		1	37	18.15	18.30	18.24	5
		1	74	18.09	18.14	18.18	5
		36	0	18.15	18.20	18.19	5
		36	19	18.07	18.19	18.22	5
		36	39	18.11	18.17	18.14	5
		75	0	18.14	18.15	18.19	5

LTE Conducted Power (Full)									
LTE Band 7									
BW	MCS Index	Channel		20800	21100	21400	3GPP MPR		
		Frequency (MHz)		2505	2535	2565			
10M	QPSK	1	0	22.83	23.05	23.02	0		
		1	24	22.81	22.87	23.06	0		
		1	49	22.89	22.95	22.92	0		
		25	0	22.22	22.34	22.34	1		
		25	12	22.09	22.13	22.27	1		
		25	25	22.05	22.10	22.13	1		
10M	16QAM	50	0	22.13	22.13	22.09	1		
		1	0	22.45	22.41	22.35	1		
		1	24	22.18	22.26	22.28	1		
		1	49	21.68	21.78	21.84	1		
		25	0	21.30	21.32	21.31	2		
		25	12	21.12	21.24	21.38	2		
10M	64QAM	25	25	20.97	21.12	21.09	2		
		50	0	21.03	21.03	21.04	2		
		1	0	21.13	21.05	21.14	2		
		1	24	21.31	21.28	21.34	2		
		1	49	20.99	21.13	21.24	2		
		25	0	20.00	20.09	20.15	3		
10M	256QAM	25	12	20.11	20.16	20.15	3		
		25	25	20.03	20.08	20.08	3		
		50	0	20.01	20.14	20.13	3		
		1	0	18.07	18.09	18.06	5		
		1	24	18.07	18.07	18.25	5		
		1	49	17.98	18.16	18.14	5		
10M	256QAM	25	0	18.11	18.09	18.18	5		
		25	12	18.05	18.13	18.17	5		
		25	25	17.96	18.12	18.11	5		
		50	0	17.95	18.09	18.05	5		
		BW	MCS Index	Channel		20775	21100	21425	3GPP MPR
		Frequency (MHz)		2502.5	2535	2567.5			
5M	QPSK	1	0	22.86	22.93	22.96	0		
		1	12	22.84	22.88	23.04	0		
		1	24	22.93	22.86	22.82	0		
		12	0	22.16	22.32	22.21	1		
		12	6	22.11	22.16	22.23	1		
		12	13	22.06	22.10	22.04	1		
5M	16QAM	25	0	22.21	22.19	22.01	1		
		1	0	22.37	22.40	22.40	1		
		1	12	22.21	22.25	22.24	1		
		1	24	21.68	21.75	21.91	1		
		12	0	21.26	21.34	21.34	2		
		12	6	21.15	21.23	21.34	2		
5M	64QAM	12	13	20.96	21.12	21.16	2		
		25	0	21.08	20.95	21.11	2		
		1	0	21.00	21.15	21.25	2		
		1	12	21.25	21.30	21.25	2		
		1	24	20.98	21.05	21.28	2		
		12	0	20.12	20.16	20.17	3		
5M	256QAM	12	6	20.11	20.28	20.22	3		
		12	13	20.05	20.09	20.06	3		
		25	0	20.08	20.16	20.25	3		
		1	0	18.04	17.97	18.01	5		
		1	12	18.12	18.10	18.05	5		
		1	24	18.02	18.02	17.99	5		
5M	256QAM	12	0	18.22	18.07	18.21	5		
		12	6	18.01	18.08	18.08	5		
		12	13	18.01	18.09	18.01	5		
		25	0	18.11	18.10	18.16	5		

LTE Conducted Power (Full)							
LTE Band 12							
BW	MCS Index	RB Size	RB Offset	Low	Mid	High	3GPP MPR (dB)
		Channel		23060	23095	23130	
		Frequency (MHz)		704	707.5	711	
10M	QPSK	1	0	22.93	22.85	23.07	0
		1	24	22.89	22.82	22.91	0
		1	49	22.74	22.65	22.81	0
		25	0	22.23	22.18	22.32	1
		25	12	22.19	22.12	22.29	1
		25	25	22.18	22.12	22.23	1
		50	0	22.21	22.17	22.29	1
10M	16QAM	1	0	22.54	22.50	22.61	1
		1	24	22.34	22.28	22.44	1
		1	49	22.43	22.37	22.45	1
		25	0	21.26	21.19	21.33	2
		25	12	21.25	21.22	21.31	2
		25	25	21.23	21.18	21.29	2
		50	0	21.15	21.07	21.18	2
10M	64QAM	1	0	21.49	21.44	21.52	2
		1	24	21.41	21.33	21.48	2
		1	49	21.40	21.31	21.42	2
		25	0	20.30	20.30	20.31	3
		25	12	20.21	20.11	20.25	3
		25	25	20.13	20.07	20.22	3
		50	0	20.28	20.26	20.28	3
10M	256QAM	1	0	18.30	18.29	18.39	5
		1	24	18.32	18.22	18.41	5
		1	49	18.25	18.19	18.29	5
		25	0	18.13	18.09	18.22	5
		25	12	18.31	18.26	18.31	5
		25	25	18.12	18.03	18.19	5
		50	0	18.18	18.18	18.22	5
BW	MCS Index	Channel		23035	23095	23155	3GPP MPR
Frequency (MHz)		701.5	707.5	713.5			
5M	QPSK	1	0	22.91	22.78	23.06	0
		1	12	22.88	22.80	22.86	0
		1	24	22.70	22.65	22.76	0
		12	0	22.23	22.12	22.28	1
		12	6	22.11	22.09	22.26	1
		12	13	22.16	22.02	22.13	1
		25	0	22.21	22.11	22.27	1
5M	16QAM	1	0	22.52	22.46	22.51	1
		1	12	22.26	22.22	22.37	1
		1	24	22.34	22.36	22.43	1
		12	0	21.17	21.13	21.26	2
		12	6	21.19	21.20	21.25	2
		12	13	21.15	21.10	21.25	2
		25	0	21.12	20.98	21.13	2
5M	64QAM	1	0	21.46	21.41	21.42	2
		1	12	21.31	21.23	21.39	2
		1	24	21.36	21.23	21.33	2
		12	0	20.27	20.27	20.27	3
		12	6	20.21	20.09	20.22	3
		12	13	20.10	20.05	20.16	3
		25	0	20.28	20.26	20.22	3
5M	256QAM	1	0	18.28	18.24	18.34	5
		1	12	18.26	18.22	18.37	5
		1	24	18.17	18.16	18.22	5
		12	0	18.04	18.00	18.15	5
		12	6	18.21	18.25	18.27	5
		12	13	18.10	17.96	18.14	5
		25	0	18.16	18.11	18.14	5

LTE Conducted Power (Full)							
LTE Band 12							
BW	MCS Index	Channel		23025	23095	23165	3GPP MPR
		Frequency (MHz)		700.5	707.5	714.5	
3M	QPSK	1	0	22.87	22.67	22.94	0
		1	7	22.88	22.69	22.75	0
		1	14	22.64	22.57	22.68	0
		8	0	22.10	22.04	22.22	1
		8	3	22.04	22.02	22.16	1
		8	7	22.03	22.00	22.12	1
		15	0	22.19	21.97	22.26	1
3M	16QAM	1	0	22.46	22.37	22.47	1
		1	7	22.22	22.17	22.30	1
		1	14	22.24	22.34	22.31	1
		8	0	21.13	21.00	21.14	2
		8	3	21.08	21.09	21.10	2
		8	7	21.02	20.97	21.14	2
		15	0	21.12	20.83	21.05	2
3M	64QAM	1	0	21.40	21.27	21.32	2
		1	7	21.19	21.08	21.31	2
		1	14	21.34	21.09	21.28	2
		8	0	20.20	20.22	20.17	3
		8	3	20.09	19.96	20.07	3
		8	7	20.10	19.93	20.11	3
		15	0	20.27	20.25	20.07	3
3M	256QAM	1	0	18.15	18.15	18.27	5
		1	7	18.22	18.13	18.37	5
		1	14	18.14	18.15	18.14	5
		8	0	17.93	17.93	18.07	5
		8	3	18.14	18.26	18.26	5
		8	7	18.05	17.92	18.00	5
		15	0	18.07	18.04	18.07	5
BW	MCS Index	Channel		23017	23095	23173	3GPP MPR
		Frequency (MHz)		699.7	707.5	715.3	
1.4M	QPSK	1	0	22.81	22.70	22.90	0
		1	2	22.69	22.74	22.75	0
		1	5	22.72	22.59	22.69	0
		3	0	23.05	23.03	23.03	0
		3	1	23.01	22.89	23.05	0
		3	3	22.90	22.95	23.02	0
		6	0	22.13	22.04	22.18	1
1.4M	16QAM	1	0	22.40	22.31	22.52	1
		1	2	22.22	22.16	22.32	1
		1	5	22.35	22.27	22.21	1
		3	0	22.04	22.15	22.18	1
		3	1	22.05	22.15	22.17	1
		3	3	22.03	22.06	22.12	1
		6	0	20.98	20.97	21.01	2
1.4M	64QAM	1	0	21.36	21.27	21.32	2
		1	2	21.29	21.25	21.29	2
		1	5	21.26	21.15	21.28	2
		3	0	21.15	21.15	21.16	2
		3	1	21.01	20.90	21.08	2
		3	3	21.01	20.89	21.20	2
		6	0	20.11	20.19	20.06	3
1.4M	256QAM	1	0	18.20	18.17	18.26	5
		1	2	18.27	18.01	18.17	5
		1	5	18.21	17.98	18.06	5
		3	0	17.94	17.93	18.11	5
		3	1	18.10	18.10	18.02	5
		3	3	18.02	17.94	17.94	5
		6	0	18.07	17.97	17.88	5

LTE Conducted Power (Full)							
LTE Band 13							
BW	MCS Index	RB Size	RB Offset	Channel		Mid	3GPP MPR (dB)
		Channel			23230		
		Frequency (MHz)			782		
10M	QPSK	1	0		23.08		0
		1	24		23.06		0
		1	49		22.91		0
		25	0		22.03		1
		25	12		22.01		1
		25	25		21.95		1
		50	0		22.06		1
10M	16QAM	1	0		22.12		1
		1	24		21.96		1
		1	49		21.81		1
		25	0		21.02		2
		25	12		21.06		2
		25	25		21.05		2
		50	0		21.03		2
10M	64QAM	1	0		21.24		2
		1	24		21.19		2
		1	49		21.11		2
		25	0		19.98		3
		25	12		20.03		3
		25	25		19.97		3
		50	0		20.05		3
10M	256QAM	1	0		18.18		5
		1	24		18.26		5
		1	49		18.03		5
		25	0		17.92		5
		25	12		17.98		5
		25	25		17.95		5
		50	0		18.01		5
BW	MCS Index	Channel		23205	23230	23255	3GPP MPR
Frequency (MHz)			779.5	782	784.5		
5M	QPSK	1	0	23.05	23.07	23.06	0
		1	12	22.86	22.99	22.96	0
		1	24	22.73	22.82	22.79	0
		12	0	21.86	21.94	21.91	1
		12	6	21.83	21.91	21.84	1
		12	13	21.81	21.91	21.86	1
		25	0	21.88	21.98	21.90	1
5M	16QAM	1	0	21.97	22.08	22.00	1
		1	12	21.87	21.91	21.91	1
		1	24	21.53	21.72	21.63	1
		12	0	20.78	20.95	20.85	2
		12	6	20.84	21.03	20.94	2
		12	13	20.94	21.04	21.04	2
		25	0	20.93	21.01	20.97	2
5M	64QAM	1	0	21.10	21.20	21.13	2
		1	12	21.00	21.11	21.10	2
		1	24	20.93	21.03	20.94	2
		12	0	19.81	19.93	19.85	3
		12	6	19.87	19.95	19.92	3
		12	13	19.78	19.94	19.85	3
		25	0	19.89	20.03	19.94	3
5M	256QAM	1	0	18.13	18.12	18.15	5
		1	12	18.16	18.25	18.12	5
		1	24	17.91	17.94	17.90	5
		12	0	17.81	17.84	17.86	5
		12	6	17.90	17.95	17.91	5
		12	13	17.76	17.89	17.86	5
		25	0	17.84	17.99	17.92	5

LTE Conducted Power (Full)							
LTE Band 14							
BW	MCS Index	RB Size	RB Offset	Channel			3GPP MPR (dB)
		Channel		23330			
		Frequency (MHz)		793			
10M	QPSK	1	0		23.04		0
		1	24		22.98		0
		1	49		22.89		0
		25	0		22.03		1
		25	12		22.01		1
		25	25		22.97		1
		50	0		21.98		1
10M	16QAM	1	0		22.28		1
		1	24		22.42		1
		1	49		22.19		1
		25	0		20.99		2
		25	12		20.96		2
		25	25		21.02		2
		50	0		20.99		2
10M	64QAM	1	0		21.22		2
		1	24		21.18		2
		1	49		21.12		2
		25	0		19.98		3
		25	12		20.03		3
		25	25		19.98		3
		50	0		19.95		3
10M	256QAM	1	0		18.11		5
		1	24		18.08		5
		1	49		17.99		5
		25	0		18.01		5
		25	12		17.94		5
		25	25		17.98		5
		50	0		17.95		5
BW	MCS Index	Channel		23305	23330	23355	3GPP MPR
		Frequency (MHz)		790.5	793	795.5	
5M	QPSK	1	0	23.01	23.02	22.99	0
		1	12	22.92	22.95	22.91	0
		1	24	22.78	22.88	22.75	0
		12	0	21.90	21.95	21.85	1
		12	6	21.86	21.95	21.77	1
		12	13	22.93	22.97	22.85	1
		25	0	21.85	21.90	21.78	1
5M	16QAM	1	0	22.16	22.25	22.10	1
		1	12	22.35	22.37	22.32	1
		1	24	22.07	22.14	22.06	1
		12	0	20.91	20.92	20.90	2
		12	6	20.87	20.94	20.84	2
		12	13	20.83	20.92	20.83	2
		25	0	20.88	20.93	20.83	2
5M	64QAM	1	0	21.11	21.13	21.07	2
		1	12	21.08	21.13	20.98	2
		1	24	21.01	21.09	20.91	2
		12	0	19.91	19.93	19.90	3
		12	6	20.02	20.02	19.96	3
		12	13	19.89	19.95	19.84	3
		25	0	19.85	19.89	19.78	3
5M	256QAM	1	0	18.04	18.10	17.99	5
		1	12	17.94	17.99	17.87	5
		1	24	17.83	17.91	17.84	5
		12	0	17.87	17.92	17.78	5
		12	6	17.83	17.88	17.77	5
		12	13	17.88	17.96	17.81	5
		25	0	17.88	17.91	17.79	5



LTE Conducted Power (Full)							
LTE Band 17							
BW	MCS Index	RB Size	RB Offset	Low	Mid	High	3GPP MPR (dB)
		Channel		23780	23790	23800	
		Frequency (MHz)		709	710	711	
10M	QPSK	1	0	22.91	23.01	22.95	0
		1	24	22.82	22.92	22.91	0
		1	49	22.70	22.81	22.80	0
		25	0	22.22	22.38	22.31	1
		25	12	22.19	22.35	22.26	1
		25	25	22.23	22.33	22.26	1
		50	0	22.34	22.36	22.35	1
10M	16QAM	1	0	22.18	22.25	22.24	1
		1	24	22.07	22.26	22.17	1
		1	49	22.07	22.14	22.11	1
		25	0	21.34	21.35	21.35	2
		25	12	21.25	21.36	21.26	2
		25	25	21.20	21.33	21.26	2
		50	0	21.38	21.39	21.38	2
10M	64QAM	1	0	21.39	21.55	21.49	2
		1	24	21.43	21.44	21.44	2
		1	49	21.40	21.46	21.41	2
		25	0	20.18	20.32	20.23	3
		25	12	20.26	20.35	20.30	3
		25	25	20.20	20.33	20.29	3
		50	0	20.22	20.36	20.31	3
10M	256QAM	1	0	18.43	18.52	18.46	5
		1	24	18.45	18.51	18.50	5
		1	49	18.26	18.35	18.33	5
		25	0	18.11	18.29	18.19	5
		25	12	18.26	18.32	18.28	5
		25	25	18.09	18.22	18.17	5
		50	0	18.32	18.35	18.32	5
BW	MCS Index	Channel		23755	23790	23825	3GPP MPR
Frequency (MHz)		706.5	710	713.5			
5M	QPSK	1	0	22.82	22.96	22.85	0
		1	12	22.73	22.87	22.90	0
		1	24	22.65	22.81	22.71	0
		12	0	22.13	22.31	22.30	1
		12	6	22.18	22.32	22.18	1
		12	13	22.15	22.31	22.22	1
		25	0	22.30	22.30	22.26	1
5M	16QAM	1	0	22.14	22.17	22.14	1
		1	12	21.98	22.20	22.10	1
		1	24	22.05	22.14	22.11	1
		12	0	21.34	21.31	21.32	2
		12	6	21.23	21.26	21.19	2
		12	13	21.17	21.31	21.18	2
		25	0	21.34	21.35	21.33	2
5M	64QAM	1	0	21.36	21.54	21.39	2
		1	12	21.35	21.42	21.34	2
		1	24	21.39	21.45	21.32	2
		12	0	20.08	20.32	20.20	3
		12	6	20.19	20.26	20.21	3
		12	13	20.17	20.33	20.21	3
		25	0	20.19	20.36	20.29	3
5M	256QAM	1	0	18.37	18.48	18.42	5
		1	12	18.41	18.44	18.48	5
		1	24	18.21	18.26	18.31	5
		12	0	18.10	18.20	18.10	5
		12	6	18.25	18.28	18.24	5
		12	13	18.04	18.17	18.10	5
		25	0	18.29	18.30	18.24	5

LTE Conducted Power (Full)							
LTE Band 25							
BW	MCS Index	RB Size	RB Offset	Low	Mid	High	3GPP MPR (dB)
		Channel		26140	26365	26590	
		Frequency (MHz)		1860	1882.5	1905	
20M	QPSK	1	0	22.41	22.49	22.52	0
		1	50	22.33	22.41	22.51	0
		1	99	22.32	22.35	22.35	0
		50	0	21.53	21.59	21.61	1
		50	25	21.43	21.48	21.55	1
		50	50	21.35	21.42	21.52	1
		100	0	21.33	21.37	21.45	1
20M	16QAM	1	0	21.65	21.65	21.73	1
		1	50	21.58	21.64	21.68	1
		1	99	21.17	21.20	21.28	1
		50	0	20.40	20.45	20.47	2
		50	25	20.27	20.36	20.44	2
		50	50	20.38	20.40	20.42	2
		100	0	20.27	20.37	20.41	2
20M	64QAM	1	0	20.50	20.59	20.64	2
		1	50	20.57	20.59	20.62	2
		1	99	20.35	20.42	20.43	2
		50	0	19.42	19.47	19.49	3
		50	25	19.29	19.35	19.44	3
		50	50	19.30	19.32	19.41	3
		100	0	19.39	19.40	19.45	3
20M	256QAM	1	0	17.74	17.78	17.88	5
		1	50	17.73	17.77	17.81	5
		1	99	17.68	17.76	17.77	5
		50	0	17.77	17.84	17.87	5
		50	25	17.75	17.78	17.84	5
		50	50	17.73	17.79	17.82	5
		100	0	17.80	17.87	17.89	5
BW	MCS Index	Channel		26115	26365	26615	3GPP MPR
		Frequency (MHz)		1857.5	1882.5	1907.5	
15M	QPSK	1	0	22.38	22.47	22.44	0
		1	37	22.25	22.35	22.50	0
		1	74	22.25	22.32	22.34	0
		36	0	21.51	21.55	21.55	1
		36	19	21.38	21.38	21.51	1
		36	39	21.27	21.39	21.52	1
		75	0	21.31	21.30	21.45	1
15M	16QAM	1	0	21.58	21.56	21.71	1
		1	37	21.53	21.64	21.60	1
		1	74	21.10	21.13	21.20	1
		36	0	20.37	20.41	20.47	2
		36	19	20.20	20.32	20.37	2
		36	39	20.31	20.38	20.36	2
		75	0	20.26	20.37	20.31	2
15M	64QAM	1	0	20.44	20.56	20.59	2
		1	37	20.47	20.57	20.61	2
		1	74	20.26	20.40	20.41	2
		36	0	19.41	19.45	19.40	3
		36	19	19.24	19.26	19.36	3
		36	39	19.26	19.24	19.37	3
		75	0	19.39	19.40	19.42	3
15M	256QAM	1	0	17.72	17.70	17.81	5
		1	37	17.67	17.72	17.73	5
		1	74	17.64	17.69	17.70	5
		36	0	17.69	17.80	17.86	5
		36	19	17.74	17.70	17.77	5
		36	39	17.73	17.75	17.82	5
		75	0	17.71	17.87	17.79	5

LTE Conducted Power (Full)							
LTE Band 25							
BW	MCS Index	Channel		26090	26365	26640	3GPP MPR
		Frequency (MHz)		1855	1882.5	1910	
10M	QPSK	1	0	22.31	22.42	22.31	0
		1	24	22.15	22.32	22.40	0
		1	49	22.13	22.13	22.30	0
		25	0	21.43	21.40	21.40	1
		25	12	21.25	21.36	21.34	1
		25	25	21.32	21.23	21.49	1
		50	0	21.19	21.20	21.32	1
10M	16QAM	1	0	21.55	21.54	21.65	1
		1	24	21.49	21.50	21.51	1
		1	49	21.08	21.10	21.26	1
		25	0	20.28	20.36	20.37	2
		25	12	20.12	20.11	20.22	2
		25	25	20.26	20.26	20.37	2
		50	0	20.18	20.23	20.23	2
10M	64QAM	1	0	20.46	20.38	20.49	2
		1	24	20.49	20.56	20.42	2
		1	49	20.17	20.35	20.20	2
		25	0	19.23	19.33	19.33	3
		25	12	19.15	19.12	19.39	3
		25	25	19.19	19.13	19.25	3
		50	0	19.16	19.37	19.31	3
10M	256QAM	1	0	17.59	17.68	17.70	5
		1	24	17.59	17.71	17.64	5
		1	49	17.58	17.62	17.59	5
		25	0	17.59	17.66	17.80	5
		25	12	17.59	17.67	17.60	5
		25	25	17.65	17.61	17.62	5
		50	0	17.65	17.74	17.73	5
BW	MCS Index	Channel		26065	26365	26665	3GPP MPR
		Frequency (MHz)		1852.5	1882.5	1912.5	
5M	QPSK	1	0	22.29	22.40	22.31	0
		1	12	22.19	22.29	22.12	0
		1	24	22.10	22.16	22.16	0
		12	0	21.45	21.53	21.35	1
		12	6	21.38	21.35	21.34	1
		12	13	21.28	21.32	21.22	1
		25	0	21.23	21.22	21.29	1
5M	16QAM	1	0	21.56	21.52	21.67	1
		1	12	21.48	21.42	21.51	1
		1	24	21.07	21.02	21.20	1
		12	0	20.26	20.39	20.41	2
		12	6	20.13	20.35	20.30	2
		12	13	20.22	20.25	20.30	2
		25	0	20.11	20.23	20.26	2
5M	64QAM	1	0	20.34	20.53	20.45	2
		1	12	20.33	20.43	20.42	2
		1	24	20.13	20.33	20.23	2
		12	0	19.25	19.32	19.27	3
		12	6	19.20	19.24	19.37	3
		12	13	19.16	19.14	19.24	3
		25	0	19.31	19.25	19.30	3
5M	256QAM	1	0	17.56	17.58	17.57	5
		1	12	17.59	17.60	17.50	5
		1	24	17.65	17.69	17.54	5
		12	0	17.66	17.62	17.76	5
		12	6	17.71	17.61	17.57	5
		12	13	17.60	17.65	17.54	5
		25	0	17.76	17.86	17.56	5

LTE Conducted Power (Full)							
LTE Band 25							
BW	MCS Index	Channel		26055	26365	26675	3GPP MPR
		Frequency (MHz)		1851.5	1882.5	1913.5	
3M	QPSK	1	0	22.28	22.24	22.51	0
		1	7	22.26	22.28	22.33	0
		1	14	22.07	22.23	22.28	0
		8	0	21.42	21.49	21.47	1
		8	3	21.33	21.41	21.41	1
		8	7	21.28	21.30	21.40	1
		15	0	21.22	21.23	21.31	1
3M	16QAM	1	0	21.50	21.54	21.64	1
		1	7	21.50	21.46	21.46	1
		1	14	21.10	21.07	21.16	1
		8	0	20.33	20.24	20.38	2
		8	3	20.08	20.23	20.32	2
		8	7	20.30	20.26	20.36	2
		15	0	20.18	20.23	20.19	2
3M	64QAM	1	0	20.45	20.48	20.46	2
		1	7	20.54	20.43	20.39	2
		1	14	20.15	20.30	20.34	2
		8	0	19.36	19.31	19.36	3
		8	3	19.22	19.15	19.31	3
		8	7	19.25	19.31	19.27	3
		15	0	19.21	19.27	19.33	3
3M	256QAM	1	0	17.57	17.70	17.71	5
		1	7	17.49	17.65	17.74	5
		1	14	17.55	17.66	17.68	5
		8	0	17.57	17.74	17.77	5
		8	3	17.59	17.72	17.73	5
		8	7	17.53	17.66	17.67	5
		15	0	17.57	17.74	17.74	5
BW	MCS Index	Channel		26047	26365	26683	3GPP MPR
		Frequency (MHz)		1850.7	1882.5	1914.3	
1.4M	QPSK	1	0	22.31	22.40	22.31	0
		1	2	22.16	22.26	22.42	0
		1	5	22.21	22.21	22.26	0
		3	0	22.38	22.37	22.41	0
		3	1	22.30	22.40	22.42	0
		3	3	22.28	22.27	22.46	0
		6	0	21.32	21.19	21.40	1
1.4M	16QAM	1	0	21.55	21.57	21.65	1
		1	2	21.40	21.53	21.68	1
		1	5	21.05	21.08	21.18	1
		3	0	21.24	21.36	21.30	1
		3	1	21.08	21.16	21.25	1
		3	3	21.22	21.36	21.28	1
		6	0	20.11	20.23	20.28	2
1.4M	64QAM	1	0	20.34	20.49	20.51	2
		1	2	20.48	20.44	20.54	2
		1	5	20.24	20.23	20.35	2
		3	0	20.34	20.38	20.41	2
		3	1	20.13	20.25	20.24	2
		3	3	20.13	20.30	20.29	2
		6	0	19.24	19.30	19.37	3
1.4M	256QAM	1	0	17.59	17.72	17.81	5
		1	2	17.69	17.62	17.62	5
		1	5	17.53	17.61	17.62	5
		3	0	17.60	17.76	17.77	5
		3	1	17.69	17.68	17.78	5
		3	3	17.58	17.68	17.74	5
		6	0	17.69	17.87	17.72	5

LTE Conducted Power (Full)							
LTE Band 26							
BW	MCS Index	RB Size	RB Offset	Low	Mid	High	3GPP MPR (dB)
		Channel		26765	26865	26965	
		Frequency (MHz)		821.5	831.5	841.5	
15M	QPSK	1	0	23.09	23.08	23.15	0
		1	37	23.07	23.01	23.08	0
		1	74	22.93	22.84	23.02	0
		36	0	22.19	22.11	22.25	1
		36	19	22.15	22.09	22.23	1
		36	39	22.11	22.06	22.21	1
		75	0	22.18	22.15	22.22	1
15M	16QAM	1	0	22.49	22.48	22.56	1
		1	37	22.55	22.53	22.55	1
		1	74	22.47	22.47	22.53	1
		36	0	21.25	21.17	21.32	2
		36	19	21.17	21.13	21.26	2
		36	39	21.19	21.18	21.25	2
		75	0	21.15	21.10	21.22	2
15M	64QAM	1	0	21.44	21.43	21.45	2
		1	37	21.32	21.31	21.38	2
		1	74	21.32	21.32	21.39	2
		36	0	20.22	20.17	20.29	3
		36	19	20.26	20.21	20.27	3
		36	39	20.23	20.20	20.23	3
		75	0	20.18	20.15	20.22	3
15M	256QAM	1	0	18.47	18.41	18.52	5
		1	37	18.45	18.39	18.51	5
		1	74	18.50	18.44	18.53	5
		36	0	18.41	18.34	18.49	5
		36	19	18.43	18.34	18.48	5
		36	39	18.38	18.37	18.46	5
		75	0	18.40	18.37	18.41	5
BW	MCS Index	Channel		26740	26865	26990	3GPP MPR
Frequency (MHz)		819	831.5	844			
10M	QPSK	1	0	22.99	23.03	23.11	0
		1	24	23.05	22.99	23.08	0
		1	49	22.86	22.74	22.93	0
		25	0	22.19	22.02	22.19	1
		25	12	22.11	22.03	22.15	1
		25	25	22.04	22.02	22.21	1
		50	0	22.17	22.10	22.21	1
10M	16QAM	1	0	22.47	22.39	22.51	1
		1	24	22.51	22.52	22.45	1
		1	49	22.41	22.46	22.43	1
		25	0	21.16	21.10	21.26	2
		25	12	21.12	21.12	21.25	2
		25	25	21.15	21.18	21.24	2
		50	0	21.15	21.01	21.21	2
10M	64QAM	1	0	21.43	21.38	21.37	2
		1	24	21.31	21.31	21.36	2
		1	49	21.27	21.32	21.30	2
		25	0	20.14	20.14	20.19	3
		25	12	20.22	20.13	20.17	3
		25	25	20.22	20.12	20.22	3
		50	0	20.11	20.13	20.20	3
10M	256QAM	1	0	18.41	18.32	18.42	5
		1	24	18.35	18.33	18.51	5
		1	49	18.47	18.40	18.50	5
		25	0	18.35	18.30	18.49	5
		25	12	18.40	18.31	18.42	5
		25	25	18.30	18.36	18.44	5
		50	0	18.35	18.37	18.40	5

LTE Conducted Power (Full)							
LTE Band 26							
BW	MCS Index	Channel		26715	26865	27015	3GPP MPR
		Frequency (MHz)		816.5	831.5	846.5	
5M	QPSK	1	0	22.96	22.97	23.07	0
		1	12	22.97	22.87	22.97	0
		1	24	22.83	22.66	22.81	0
		12	0	22.17	21.97	22.09	1
		12	6	21.96	21.99	22.03	1
		12	13	22.01	22.01	22.06	1
		25	0	22.11	22.04	22.17	1
5M	16QAM	1	0	22.37	22.24	22.46	1
		1	12	22.47	22.40	22.37	1
		1	24	22.28	22.36	22.43	1
		12	0	21.15	21.05	21.11	2
		12	6	21.00	21.02	21.22	2
		12	13	21.07	21.14	21.24	2
		25	0	21.03	20.95	21.20	2
5M	64QAM	1	0	21.37	21.25	21.23	2
		1	12	21.27	21.31	21.30	2
		1	24	21.21	21.29	21.20	2
		12	0	20.14	20.10	20.09	3
		12	6	20.09	20.06	20.03	3
		12	13	20.21	20.05	20.09	3
		25	0	20.03	20.09	20.14	3
5M	256QAM	1	0	18.45	18.17	18.45	5
		1	12	18.31	18.22	18.40	5
		1	24	18.35	18.32	18.44	5
		12	0	18.25	18.25	18.37	5
		12	6	18.31	18.26	18.39	5
		12	13	18.27	18.25	18.34	5
		25	0	18.20	18.35	18.27	5
BW	MCS Index	Channel		26705	26865	27025	3GPP MPR
		Frequency (MHz)		815.5	831.5	847.5	
3M	QPSK	1	0	22.93	22.93	22.99	0
		1	7	23.00	22.85	22.91	0
		1	14	22.83	22.74	22.78	0
		8	0	22.08	21.97	22.01	1
		8	3	22.08	22.01	21.94	1
		8	7	21.97	21.98	21.95	1
		15	0	22.17	21.95	22.16	1
3M	16QAM	1	0	22.32	22.33	22.49	1
		1	7	22.48	22.47	22.44	1
		1	14	22.26	22.41	22.29	1
		8	0	21.03	21.02	21.25	2
		8	3	21.12	21.08	21.13	2
		8	7	21.02	21.18	21.14	2
		15	0	21.04	20.94	21.11	2
3M	64QAM	1	0	21.35	21.27	21.35	2
		1	7	21.23	21.23	21.35	2
		1	14	21.25	21.28	21.26	2
		8	0	20.12	20.05	20.10	3
		8	3	20.12	20.05	20.05	3
		8	7	20.16	19.98	20.07	3
		15	0	20.06	20.00	20.17	3
3M	256QAM	1	0	18.30	18.24	18.38	5
		1	7	18.42	18.18	18.31	5
		1	14	18.44	18.29	18.24	5
		8	0	18.21	18.34	18.17	5
		8	3	18.22	18.34	18.22	5
		8	7	18.30	18.18	18.19	5
		15	0	18.31	18.26	18.30	5

LTE Conducted Power (Full)							
LTE Band 26							
BW	MCS Index	Channel		26697	26865	27033	3GPP MPR
		Frequency (MHz)		814.7	831.5	848.3	
1.4M	QPSK	1	0	22.94	23.02	23.02	0
		1	2	22.95	22.88	23.05	0
		1	5	22.72	22.59	22.89	0
		3	0	23.09	22.96	23.13	0
		3	1	23.05	22.89	23.04	0
		3	3	22.90	22.94	23.12	0
		6	0	22.13	21.97	22.11	1
1.4M	16QAM	1	0	22.43	22.36	22.36	1
		1	2	22.36	22.48	22.31	1
		1	5	22.27	22.44	22.32	1
		3	0	22.11	22.05	22.20	1
		3	1	21.97	22.00	22.25	1
		3	3	22.14	22.03	22.10	1
		6	0	21.05	20.88	21.08	2
1.4M	64QAM	1	0	21.40	21.34	21.28	2
		1	2	21.28	21.23	21.34	2
		1	5	21.15	21.29	21.18	2
		3	0	21.00	21.08	21.17	2
		3	1	21.09	20.98	21.08	2
		3	3	21.18	20.98	21.07	2
		6	0	20.01	20.00	20.06	3
1.4M	256QAM	1	0	18.30	18.35	18.45	5
		1	2	18.20	18.26	18.43	5
		1	5	18.43	18.36	18.38	5
		3	0	18.31	18.15	18.36	5
		3	1	18.40	18.15	18.36	5
		3	3	18.36	18.24	18.38	5
		6	0	18.16	18.21	18.22	5

LTE Conducted Power (Full)							
LTE Band 30							
BW	MCS Index	RB Size	RB Offset	Channel			3GPP MPR (dB)
		Channel		27710			
		Frequency (MHz)		2310			
10M	QPSK	1	0		22.71		0
		1	24		22.68		0
		1	49		22.66		0
		25	0		21.74		1
		25	12		21.61		1
		25	25		21.58		1
		50	0		21.62		1
10M	16QAM	1	0		21.93		1
		1	24		21.96		1
		1	49		21.90		1
		25	0		20.77		2
		25	12		20.69		2
		25	25		20.63		2
		50	0		20.61		2
10M	64QAM	1	0		20.87		2
		1	24		20.81		2
		1	49		20.79		2
		25	0		19.68		3
		25	12		19.63		3
		25	25		19.52		3
		50	0		19.62		3
10M	256QAM	1	0		17.79		5
		1	24		17.66		5
		1	49		17.67		5
		25	0		17.57		5
		25	12		17.61		5
		25	25		17.56		5
		50	0		17.52		5
BW	MCS Index	Channel		27685	27710	27735	3GPP MPR
		Frequency (MHz)		2307.5	2310	2312.5	
5M	QPSK	1	0	22.69	22.70	22.58	0
		1	12	22.63	22.68	22.57	0
		1	24	22.61	22.66	22.55	0
		12	0	21.67	21.75	21.67	1
		12	6	21.57	21.61	21.54	1
		12	13	21.56	21.58	21.46	1
		25	0	21.62	21.63	21.52	1
5M	16QAM	1	0	21.83	21.93	21.76	1
		1	12	21.86	21.96	21.84	1
		1	24	21.89	21.90	21.82	1
		12	0	20.71	20.77	20.61	2
		12	6	20.59	20.69	20.49	2
		12	13	20.57	20.63	20.51	2
		25	0	20.56	20.61	20.52	2
5M	64QAM	1	0	20.78	20.87	20.69	2
		1	12	20.78	20.81	20.68	2
		1	24	20.75	20.79	20.72	2
		12	0	19.66	19.68	19.56	3
		12	6	19.53	19.63	19.44	3
		12	13	19.45	19.52	19.40	3
		25	0	19.59	19.62	19.56	3
5M	256QAM	1	0	17.67	17.72	17.58	5
		1	12	17.56	17.60	17.56	5
		1	24	17.52	17.59	17.47	5
		12	0	17.46	17.53	17.39	5
		12	6	17.55	17.54	17.47	5
		12	13	17.47	17.56	17.41	5
		25	0	17.49	17.51	17.46	5



LTE Conducted Power (Full)							
LTE Band 38							
BW	MCS Index	RB Size	RB Offset	Low	Mid	High	3GPP MPR (dB)
		Channel		37850	38000	38150	
		Frequency (MHz)		2580	2595	2610	
20M	QPSK	1	0	23.38	23.29	23.27	0
		1	50	23.36	23.25	23.22	0
		1	99	23.25	23.16	23.12	0
		50	0	22.39	22.23	22.16	1
		50	25	22.38	22.22	22.15	1
		50	50	22.31	22.20	22.13	1
		100	0	22.33	22.15	22.10	1
20M	16QAM	1	0	22.58	22.40	22.30	1
		1	50	22.61	22.49	22.47	1
		1	99	22.44	22.21	22.15	1
		50	0	21.48	21.38	21.34	2
		50	25	21.46	21.40	21.32	2
		50	50	21.39	21.15	21.11	2
		100	0	21.35	21.12	21.02	2
20M	64QAM	1	0	21.33	21.18	21.09	2
		1	50	21.32	21.23	21.21	2
		1	99	21.21	20.96	20.88	2
		50	0	20.46	20.35	20.30	3
		50	25	20.38	20.22	20.20	3
		50	50	20.35	20.24	20.22	3
		100	0	20.33	20.17	20.17	3
20M	256QAM	1	0	18.31	18.22	18.18	5
		1	50	18.39	18.34	18.30	5
		1	99	18.18	18.12	18.10	5
		50	0	18.42	18.39	18.36	5
		50	25	18.39	18.38	18.37	5
		50	50	18.36	18.35	18.34	5
		100	0	18.32	18.29	18.21	5
BW	MCS Index	Channel		37825	38000	38175	3GPP MPR
Frequency (MHz)		2577.5	2595	2612.5			
15M	QPSK	1	0	23.30	23.20	23.23	0
		1	37	23.32	23.25	23.16	0
		1	74	23.21	23.12	23.04	0
		36	0	22.38	22.17	22.16	1
		36	19	22.30	22.12	22.07	1
		36	39	22.23	22.12	22.09	1
		75	0	22.30	22.10	22.10	1
15M	16QAM	1	0	22.53	22.37	22.22	1
		1	37	22.61	22.39	22.47	1
		1	74	22.43	22.14	22.15	1
		36	0	21.38	21.28	21.25	2
		36	19	21.36	21.35	21.24	2
		36	39	21.32	21.14	21.09	2
		75	0	21.35	21.09	20.96	2
15M	64QAM	1	0	21.33	21.17	21.07	2
		1	37	21.30	21.19	21.19	2
		1	74	21.20	20.90	20.78	2
		36	0	20.40	20.26	20.21	3
		36	19	20.35	20.18	20.17	3
		36	39	20.27	20.18	20.18	3
		75	0	20.29	20.17	20.14	3
15M	256QAM	1	0	18.27	18.14	18.15	5
		1	37	18.35	18.24	18.26	5
		1	74	18.08	18.10	18.09	5
		36	0	18.41	18.37	18.31	5
		36	19	18.32	18.32	18.35	5
		36	39	18.31	18.28	18.31	5
		75	0	18.26	18.25	18.12	5

LTE Conducted Power (Full)									
LTE Band 38									
BW	MCS Index	Channel		37800	38000	38200	3GPP MPR		
		Frequency (MHz)		2575	2595	2615			
10M	QPSK	1	0	23.30	23.13	23.23	0		
		1	24	23.21	23.21	23.02	0		
		1	49	23.20	23.02	22.95	0		
		25	0	22.37	22.16	22.09	1		
		25	12	22.16	22.04	21.93	1		
		25	25	22.20	22.07	22.04	1		
10M	16QAM	50	0	22.21	22.06	22.00	1		
		1	0	22.44	22.23	22.15	1		
		1	24	22.59	22.30	22.47	1		
		1	49	22.40	21.99	22.02	1		
		25	0	21.26	21.20	21.23	2		
		25	12	21.35	21.27	21.22	2		
10M	64QAM	25	25	21.24	20.99	21.00	2		
		50	0	21.25	21.01	20.90	2		
		1	0	21.30	21.17	21.05	2		
		1	24	21.21	21.12	21.11	2		
		1	49	21.08	20.77	20.69	2		
		25	0	20.25	20.19	20.19	3		
10M	256QAM	25	12	20.32	20.06	20.08	3		
		25	25	20.21	20.07	20.15	3		
		50	0	20.21	20.08	20.03	3		
		1	0	18.11	18.12	18.06	5		
		1	24	18.28	18.18	18.20	5		
		1	49	18.06	17.97	17.93	5		
10M	256QAM	25	0	18.40	18.20	18.25	5		
		25	12	18.30	18.22	18.33	5		
		25	25	18.22	18.22	18.20	5		
		50	0	18.28	18.15	17.97	5		
		BW	MCS Index	Channel		37775	38000	38225	3GPP MPR
		Frequency (MHz)		2572.5	2595	2617.5			
5M	QPSK	1	0	23.21	23.05	23.10	0		
		1	12	23.30	23.20	22.90	0		
		1	24	23.13	23.07	22.91	0		
		12	0	22.36	22.16	21.96	1		
		12	6	22.30	22.10	21.92	1		
		12	13	22.17	21.97	22.04	1		
5M	16QAM	25	0	22.24	22.03	21.99	1		
		1	0	22.47	22.31	22.07	1		
		1	12	22.48	22.30	22.34	1		
		1	24	22.35	22.12	22.09	1		
		12	0	21.36	21.24	21.12	2		
		12	6	21.35	21.35	21.13	2		
5M	64QAM	12	13	21.25	21.11	21.06	2		
		25	0	21.32	20.97	20.95	2		
		1	0	21.33	21.09	21.03	2		
		1	12	21.18	21.19	21.13	2		
		1	24	21.10	20.79	20.71	2		
		12	0	20.30	20.24	20.12	3		
5M	256QAM	12	6	20.20	20.12	20.09	3		
		12	13	20.12	20.18	20.09	3		
		25	0	20.28	20.07	20.14	3		
		1	0	18.24	18.00	18.01	5		
		1	12	18.35	18.19	18.14	5		
		1	24	18.03	17.94	17.90	5		
5M	256QAM	12	0	18.23	18.38	18.19	5		
		12	6	18.23	18.23	18.05	5		
		12	13	18.20	18.30	18.10	5		
		25	0	18.15	18.18	18.01	5		

LTE Conducted Power (Full)							
LTE Band 40							
BW	MCS Index	RB Size	RB Offset	Low	Mid	Mid	3GPP MPR (dB)
		Channel		38750	39150	39550	
		Frequency (MHz)		2310	2350	2390	
20M	QPSK	1	0	23.33	23.41	23.28	0
		1	50	23.27	23.38	23.25	0
		1	99	23.12	23.18	23.10	0
		50	0	22.36	22.38	22.28	1
		50	25	22.25	22.35	22.20	1
		50	50	22.32	22.33	22.22	1
		100	0	22.25	22.31	22.15	1
20M	16QAM	1	0	22.27	22.36	22.25	1
		1	50	22.34	22.35	22.27	1
		1	99	22.10	22.13	22.10	1
		50	0	21.29	21.33	21.25	2
		50	25	21.28	21.32	21.20	2
		50	50	21.38	21.38	21.38	2
		100	0	21.22	21.32	21.12	2
20M	64QAM	1	0	21.03	21.07	21.01	2
		1	50	20.93	21.03	20.91	2
		1	99	20.80	20.81	20.75	2
		50	0	20.29	20.38	20.26	3
		50	25	20.29	20.36	20.25	3
		50	50	20.33	20.35	20.26	3
		100	0	20.29	20.32	20.27	3
20M	256QAM	1	0	18.17	18.18	18.07	5
		1	50	18.07	18.16	18.01	5
		1	99	17.95	18.02	17.91	5
		50	0	18.34	18.38	18.24	5
		50	25	18.31	18.36	18.28	5
		50	50	18.19	18.29	18.13	5
		100	0	18.24	18.28	18.17	5
BW	MCS Index	Channel		38725	39150	39575	3GPP MPR
Frequency (MHz)		2307.5	2350	2392.5			
15M	QPSK	1	0	23.23	23.39	23.18	0
		1	37	23.19	23.35	23.22	0
		1	74	23.07	23.14	23.03	0
		36	0	22.35	22.29	22.20	1
		36	19	22.15	22.31	22.16	1
		36	39	22.28	22.30	22.17	1
		75	0	22.15	22.23	22.09	1
15M	16QAM	1	0	22.22	22.30	22.25	1
		1	37	22.24	22.34	22.17	1
		1	74	22.01	22.03	22.04	1
		36	0	21.24	21.32	21.25	2
		36	19	21.18	21.23	21.12	2
		36	39	21.37	21.38	21.37	2
		75	0	21.18	21.22	21.11	2
15M	64QAM	1	0	20.99	21.01	20.99	2
		1	37	20.90	20.98	20.83	2
		1	74	20.78	20.78	20.74	2
		36	0	20.21	20.31	20.20	3
		36	19	20.20	20.30	20.24	3
		36	39	20.31	20.35	20.23	3
		75	0	20.26	20.22	20.18	3
15M	256QAM	1	0	18.16	18.08	17.99	5
		1	37	18.06	18.09	18.00	5
		1	74	17.93	17.94	17.89	5
		36	0	18.34	18.28	18.18	5
		36	19	18.24	18.34	18.27	5
		36	39	18.12	18.23	18.09	5
		75	0	18.17	18.23	18.17	5

LTE Conducted Power (Full)							
LTE Band 40							
BW	MCS Index	Channel		38700	39150	39600	3GPP MPR
		Frequency (MHz)		2305	2350	2395	
10M	QPSK	1	0	23.16	23.39	23.17	0
		1	24	23.07	23.35	23.12	0
		1	49	22.99	23.06	23.02	0
		25	0	22.20	22.27	22.11	1
		25	12	22.15	22.30	22.04	1
		25	25	22.23	22.15	22.06	1
		50	0	22.06	22.15	22.06	1
10M	16QAM	1	0	22.07	22.25	22.11	1
		1	24	22.20	22.21	22.14	1
		1	49	21.86	21.89	21.94	1
		25	0	21.09	21.20	21.17	2
		25	12	21.18	21.19	21.08	2
		25	25	21.31	21.32	21.33	2
		50	0	21.07	21.21	21.10	2
10M	64QAM	1	0	20.84	20.89	20.94	2
		1	24	20.81	20.88	20.70	2
		1	49	20.70	20.69	20.60	2
		25	0	20.13	20.23	20.19	3
		25	12	20.06	20.15	20.20	3
		25	25	20.22	20.34	20.12	3
		50	0	20.14	20.17	20.05	3
10M	256QAM	1	0	18.01	18.09	17.97	5
		1	24	18.01	18.05	17.93	5
		1	49	17.89	17.93	17.79	5
		25	0	18.20	18.28	18.18	5
		25	12	18.16	18.26	18.14	5
		25	25	18.01	18.13	18.01	5
		50	0	18.14	18.08	18.15	5
BW	MCS Index	Channel		38675	39150	39625	3GPP MPR
		Frequency (MHz)		2302.5	2350	2397.5	
5M	QPSK	1	0	23.23	23.25	23.10	0
		1	12	23.17	23.34	22.99	0
		1	24	22.96	23.07	22.95	0
		12	0	22.26	22.28	22.05	1
		12	6	22.11	22.17	21.95	1
		12	13	22.27	22.17	21.93	1
		25	0	22.10	22.08	21.94	1
5M	16QAM	1	0	22.15	22.21	22.20	1
		1	12	22.19	22.32	22.02	1
		1	24	21.97	21.88	21.90	1
		12	0	21.21	21.20	21.15	2
		12	6	21.10	21.14	21.01	2
		12	13	21.33	21.37	21.33	2
		25	0	21.06	21.14	21.02	2
5M	64QAM	1	0	20.91	20.92	20.93	2
		1	12	20.86	20.97	20.68	2
		1	24	20.75	20.72	20.65	2
		12	0	20.11	20.23	20.20	3
		12	6	20.19	20.30	20.22	3
		12	13	20.23	20.32	20.13	3
		25	0	20.26	20.09	20.12	3
5M	256QAM	1	0	18.15	18.01	17.79	5
		1	12	18.00	18.16	17.77	5
		1	24	17.73	17.99	17.71	5
		12	0	18.20	18.36	17.92	5
		12	6	18.08	18.27	18.13	5
		12	13	18.09	18.23	17.99	5
		25	0	18.04	18.11	18.07	5

LTE Conducted Power (Full)									
LTE Band 41_PC2									
BW	MCS Index	RB Size	RB Offset	Low	Mid	Mid	Mid	High	3GPP MPR (dB)
		Channel		39750	40185	40620	41055	41490	
		Frequency (MHz)		2506	2549.5	2593	2636.5	2680	
20M	QPSK	1	0	26.53	26.63	26.71	26.73	26.65	0
		1	50	26.44	26.51	26.61	26.66	26.57	0
		1	99	26.31	26.45	26.52	26.56	26.51	0
		50	0	25.71	25.86	25.93	25.99	25.90	1
		50	25	25.71	25.83	25.94	25.97	25.89	1
		50	50	25.75	25.80	25.86	25.94	25.84	1
		100	0	25.74	25.86	25.94	25.96	25.88	1
20M	16QAM	1	0	25.53	25.65	25.88	25.96	25.83	1
		1	50	25.36	25.47	25.93	25.93	25.86	1
		1	99	25.41	25.51	25.76	25.78	25.67	1
		50	0	24.71	24.80	24.82	24.86	24.74	2
		50	25	24.72	24.87	24.84	24.85	24.80	2
		50	50	24.72	24.84	24.72	24.77	24.70	2
		100	0	24.73	24.82	24.69	24.75	24.59	2
20M	64QAM	1	0	24.55	24.61	24.72	24.73	24.65	2
		1	50	24.45	24.56	24.89	24.97	24.80	2
		1	99	24.31	24.41	24.90	24.92	24.84	2
		50	0	23.80	23.88	23.91	23.93	23.81	3
		50	25	23.75	23.89	23.81	23.91	23.74	3
		50	50	23.65	23.74	23.80	23.88	23.77	3
		100	0	23.78	23.86	23.82	23.83	23.78	3
20M	256QAM	1	0	21.73	21.75	21.81	21.88	21.76	5
		1	50	21.72	21.73	21.84	21.84	21.82	5
		1	99	21.74	21.77	21.83	21.91	21.79	5
		50	0	21.81	21.81	21.89	21.95	21.82	5
		50	25	21.63	21.67	21.78	21.88	21.77	5
		50	50	21.64	21.74	21.85	21.85	21.80	5
		100	0	21.59	21.61	21.74	21.84	21.65	5
BW	MCS Index	Channel		39725	40173	40620	41068	41515	3GPP MPR
		Frequency (MHz)		2503.5	2548.3	2593	2637.8	2682.5	
15M	QPSK	1	0	26.44	26.59	26.68	26.67	26.57	0
		1	37	26.35	26.49	26.53	26.66	26.50	0
		1	74	26.21	26.42	26.47	26.50	26.46	0
		36	0	25.63	25.85	25.85	25.96	25.81	1
		36	19	25.66	25.77	25.93	25.96	25.82	1
		36	39	25.74	25.74	25.83	25.92	25.75	1
		75	0	25.73	25.77	25.89	25.86	25.86	1
15M	16QAM	1	0	25.45	25.62	25.87	25.92	25.60	1
		1	37	25.27	25.41	25.91	25.87	25.48	1
		1	74	25.32	25.44	25.67	25.73	25.44	1
		36	0	24.71	24.78	24.82	24.83	24.84	2
		36	19	24.63	24.81	24.74	24.78	24.86	2
		36	39	24.68	24.80	24.69	24.71	24.84	2
		75	0	24.71	24.75	24.61	24.66	24.86	2
15M	64QAM	1	0	24.46	24.57	24.72	24.65	24.60	2
		1	37	24.35	24.53	24.80	24.91	24.48	2
		1	74	24.22	24.37	24.88	24.88	24.51	2
		36	0	23.80	23.84	23.86	23.90	23.84	3
		36	19	23.69	23.86	23.71	23.81	23.83	3
		36	39	23.57	23.65	23.71	23.85	23.76	3
		75	0	23.77	23.83	23.79	23.78	23.86	3
15M	256QAM	1	0	21.71	21.70	21.77	21.79	21.73	5
		1	37	21.66	21.63	21.79	21.82	21.79	5
		1	74	21.71	21.67	21.76	21.90	21.73	5
		36	0	21.75	21.72	21.87	21.86	21.80	5
		36	19	21.57	21.58	21.68	21.84	21.72	5
		36	39	21.54	21.69	21.77	21.83	21.72	5
		75	0	21.59	21.61	21.66	21.78	21.65	5

LTE Conducted Power (Full)											
LTE Band 41_PC2											
BW	MCS Index	Channel		39700	40160	40620	41080	41540	3GPP MPR		
		Frequency (MHz)		2501	2547	2593	2639	2685			
10M	QPSK	1	0	26.34	26.49	26.67	26.60	26.52	0		
		1	24	26.35	26.41	26.43	26.56	26.46	0		
		1	49	26.11	26.35	26.43	26.45	26.40	0		
		25	0	25.63	25.85	25.77	25.88	25.71	1		
		25	12	25.61	25.68	25.88	25.88	25.75	1		
		25	25	25.66	25.70	25.74	25.91	25.69	1		
10M	16QAM	50	0	25.68	25.75	25.82	25.80	25.84	1		
		1	0	25.34	25.57	25.67	25.61	25.55	1		
		1	24	25.32	25.49	25.46	25.58	25.40	1		
		1	49	25.11	25.34	25.41	25.46	25.43	1		
		25	0	24.57	24.78	24.79	24.87	24.81	2		
		25	12	24.62	24.74	24.92	24.87	24.72	2		
10M	64QAM	25	25	24.67	24.71	24.74	24.85	24.71	2		
		50	0	24.72	24.73	24.86	24.76	24.83	2		
		1	0	24.43	24.57	24.68	24.61	24.57	2		
		1	24	24.33	24.42	24.43	24.60	24.41	2		
		1	49	24.18	24.38	24.42	24.48	24.46	2		
		25	0	23.53	23.83	23.85	23.93	23.73	3		
10M	256QAM	25	12	23.60	23.73	23.88	23.93	23.77	3		
		25	25	23.65	23.67	23.82	23.89	23.66	3		
		50	0	23.69	23.73	23.81	23.84	23.79	3		
		1	0	21.66	21.67	21.76	21.78	21.75	5		
		1	24	21.72	21.67	21.78	21.80	21.81	5		
		1	49	21.68	21.74	21.74	21.87	21.73	5		
10M	256QAM	25	0	21.80	21.71	21.86	21.93	21.75	5		
		25	12	21.54	21.61	21.72	21.85	21.76	5		
		25	25	21.64	21.68	21.77	21.77	21.73	5		
		50	0	21.58	21.56	21.66	21.79	21.59	5		
		BW	MCS Index	Channel		39675	40148	40620	41093	41565	3GPP MPR
				Frequency (MHz)		2498.5	2545.8	2593	2640.3	2687.5	
5M	QPSK	1	0	26.38	26.56	26.61	26.65	26.53	0		
		1	12	26.35	26.46	26.44	26.59	26.50	0		
		1	24	26.20	26.34	26.43	26.40	26.36	0		
		12	0	25.59	25.80	25.82	25.94	25.71	1		
		12	6	25.56	25.76	25.85	25.91	25.78	1		
		12	13	25.70	25.68	25.73	25.87	25.66	1		
		25	0	25.68	25.76	25.85	25.81	25.80	1		
5M	16QAM	1	0	25.40	25.55	25.58	25.61	25.53	1		
		1	12	25.33	25.41	25.50	25.58	25.42	1		
		1	24	25.17	25.40	25.39	25.44	25.46	1		
		12	0	24.55	24.82	24.82	24.93	24.81	2		
		12	6	24.66	24.67	24.85	24.92	24.79	2		
		12	13	24.65	24.66	24.83	24.83	24.74	2		
		25	0	24.67	24.70	24.84	24.85	24.81	2		
5M	64QAM	1	0	24.38	24.52	24.67	24.65	24.50	2		
		1	12	24.32	24.43	24.45	24.60	24.46	2		
		1	24	24.14	24.36	24.47	24.42	24.42	2		
		12	0	23.56	23.83	23.78	23.86	23.75	3		
		12	6	23.56	23.70	23.91	23.86	23.79	3		
		12	13	23.72	23.67	23.78	23.83	23.71	3		
		25	0	23.66	23.73	23.82	23.80	23.80	3		
5M	256QAM	1	0	21.67	21.64	21.70	21.79	21.69	5		
		1	12	21.64	21.54	21.74	21.71	21.66	5		
		1	24	21.66	21.76	21.78	21.78	21.65	5		
		12	0	21.75	21.67	21.74	21.85	21.65	5		
		12	6	21.59	21.56	21.69	21.83	21.72	5		
		12	13	21.54	21.67	21.79	21.73	21.70	5		
		25	0	21.45	21.51	21.62	21.69	21.51	5		

LTE Conducted Power (Full)									
LTE Band 41_PC3									
BW	MCS Index	RB Size	RB Offset	Low	Mid	Mid	Mid	High	3GPP MPR (dB)
		Channel		39750	40185	40620	41055	41490	
		Frequency (MHz)		2506	2549.5	2593	2636.5	2680	
20M	QPSK	1	0	23.95	23.73	23.97	23.99	23.98	0
		1	50	23.86	23.71	23.92	23.98	23.94	0
		1	99	23.84	23.68	23.89	23.95	23.95	0
		50	0	22.94	22.88	22.95	22.99	22.98	1
		50	25	22.89	22.84	22.91	22.98	22.98	1
		50	50	22.83	22.81	22.83	22.97	22.93	1
		100	0	22.76	22.67	22.84	22.96	22.86	1
20M	16QAM	1	0	22.97	22.90	22.97	22.98	22.95	1
		1	50	22.91	22.76	22.89	22.97	22.96	1
		1	99	22.79	22.65	22.88	22.92	22.90	1
		50	0	21.98	21.83	21.93	21.99	21.94	2
		50	25	21.83	21.84	21.90	21.98	21.92	2
		50	50	21.81	21.73	21.88	21.95	21.89	2
		100	0	21.80	21.67	21.86	21.94	21.90	2
20M	64QAM	1	0	21.95	21.81	21.88	21.79	21.95	2
		1	50	21.85	21.76	21.91	21.78	21.95	2
		1	99	21.82	21.69	21.86	21.65	21.89	2
		50	0	20.90	20.93	20.95	21.15	20.90	3
		50	25	20.84	20.81	20.98	21.11	20.94	3
		50	50	20.73	20.72	20.83	21.09	20.97	3
		100	0	20.84	20.69	20.77	21.05	20.91	3
20M	256QAM	1	0	18.86	18.72	18.91	18.97	18.97	5
		1	50	18.74	18.66	18.83	18.93	18.86	5
		1	99	18.63	18.55	18.70	18.79	18.70	5
		50	0	18.79	18.79	18.84	18.96	18.93	5
		50	25	18.83	18.70	18.83	18.95	18.87	5
		50	50	18.88	18.75	18.91	18.93	18.91	5
		100	0	18.80	18.67	18.82	18.91	18.90	5
BW	MCS Index	Channel		39725	40173	40620	41068	41515	3GPP MPR
		Frequency (MHz)		2503.5	2548.3	2593	2637.8	2682.5	
15M	QPSK	1	0	23.95	23.64	23.88	23.91	23.97	0
		1	37	23.76	23.70	23.89	23.92	23.85	0
		1	74	23.74	23.66	23.83	23.86	23.89	0
		36	0	22.94	22.80	22.89	22.99	22.95	1
		36	19	22.86	22.76	22.87	22.98	22.97	1
		36	39	22.82	22.79	22.76	22.94	22.88	1
		75	0	22.69	22.60	22.81	22.89	22.77	1
15M	16QAM	1	0	22.87	22.67	22.93	22.96	22.90	1
		1	37	22.77	22.63	22.89	22.97	22.91	1
		1	74	22.75	22.60	22.89	22.95	22.91	1
		36	0	21.87	21.81	21.87	21.91	21.92	2
		36	19	21.88	21.79	21.82	21.97	21.93	2
		36	39	21.77	21.79	21.81	21.87	21.88	2
		75	0	21.69	21.66	21.79	21.87	21.82	2
15M	64QAM	1	0	21.86	21.70	21.95	21.89	21.94	2
		1	37	21.86	21.69	21.85	21.89	21.90	2
		1	74	21.80	21.63	21.85	21.85	21.85	2
		36	0	20.85	20.81	20.85	20.93	20.93	3
		36	19	20.81	20.75	20.84	20.88	20.93	3
		36	39	20.81	20.77	20.76	20.87	20.83	3
		75	0	20.71	20.67	20.74	20.92	20.82	3
15M	256QAM	1	0	21.79	21.64	21.89	21.92	21.88	5
		1	37	21.67	21.64	21.80	21.91	21.77	5
		1	74	21.59	21.45	21.67	21.78	21.60	5
		36	0	20.70	20.70	20.74	20.91	20.86	5
		36	19	20.79	20.66	20.79	20.88	20.77	5
		36	39	20.83	20.72	20.84	20.91	20.91	5
		75	0	20.73	20.59	20.78	20.82	20.81	5

LTE Conducted Power (Full)											
LTE Band 41_PC3											
BW	MCS Index	Channel		39700	40160	40620	41080	41540	3GPP MPR		
		Frequency (MHz)		2501	2547	2593	2639	2685			
10M	QPSK	1	0	23.85	23.57	23.85	23.88	23.95	0		
		1	24	23.77	23.54	23.86	23.90	23.88	0		
		1	49	23.72	23.55	23.75	23.86	23.84	0		
		25	0	22.85	22.76	22.78	22.97	22.86	1		
		25	12	22.78	22.74	22.82	22.94	22.83	1		
		25	25	22.69	22.69	22.75	22.87	22.76	1		
10M	16QAM	50	0	22.74	22.63	22.69	22.84	22.76	1		
		1	0	22.88	22.56	22.80	22.94	22.85	1		
		1	24	22.76	22.55	22.83	22.88	22.89	1		
		1	49	22.72	22.57	22.73	22.87	22.81	1		
		25	0	21.86	21.73	21.78	21.94	21.87	2		
		25	12	21.78	21.68	21.73	21.95	21.81	2		
10M	64QAM	25	25	21.67	21.69	21.74	21.82	21.77	2		
		50	0	21.71	21.62	21.75	21.83	21.71	2		
		1	0	21.87	21.65	21.88	21.85	21.87	2		
		1	24	21.71	21.51	21.87	21.91	21.90	2		
		1	49	21.70	21.61	21.74	21.87	21.84	2		
		25	0	20.86	20.71	20.78	20.89	20.85	3		
10M	256QAM	25	12	20.77	20.76	20.74	20.93	20.85	3		
		25	25	20.64	20.73	20.72	20.87	20.84	3		
		50	0	20.73	20.62	20.67	20.84	20.77	3		
		1	0	21.72	21.63	21.80	21.91	21.83	5		
		1	24	21.64	21.54	21.82	21.86	21.81	5		
		1	49	21.55	21.41	21.63	21.69	21.68	5		
10M	256QAM	25	0	20.74	20.65	20.70	20.90	20.77	5		
		25	12	20.78	20.64	20.72	20.87	20.85	5		
		25	25	20.77	20.61	20.82	20.78	20.81	5		
		50	0	20.71	20.61	20.76	20.73	20.87	5		
		BW	MCS Index	Channel		39675	40148	40620	41093	41565	3GPP MPR
				Frequency (MHz)		2498.5	2545.8	2593	2640.3	2687.5	
5M	QPSK	1	0	23.89	23.69	23.84	23.84	23.86	0		
		1	12	23.75	23.63	23.83	23.90	23.85	0		
		1	24	23.67	23.52	23.83	23.81	23.83	0		
		12	0	22.92	22.73	22.83	22.85	22.92	1		
		12	6	22.89	22.81	22.76	22.83	22.96	1		
		12	13	22.65	22.74	22.72	22.85	22.83	1		
5M	16QAM	25	0	22.67	22.58	22.68	22.88	22.77	1		
		1	0	22.88	22.67	22.88	22.82	22.88	1		
		1	12	22.73	22.61	22.76	22.88	22.92	1		
		1	24	22.75	22.52	22.82	22.88	22.85	1		
		12	0	21.92	21.79	21.84	21.92	21.89	2		
		12	6	21.86	21.81	21.74	21.78	21.96	2		
5M	64QAM	12	13	21.67	21.71	21.78	21.82	21.88	2		
		25	0	21.60	21.49	21.71	21.91	21.76	2		
		1	0	21.89	21.62	21.93	21.91	21.87	2		
		1	12	21.82	21.58	21.77	21.90	21.94	2		
		1	24	21.69	21.53	21.80	21.79	21.86	2		
		12	0	20.85	20.71	20.84	20.86	20.91	3		
5M	256QAM	12	6	20.79	20.73	20.79	20.87	20.95	3		
		12	13	20.71	20.66	20.73	20.86	20.87	3		
		25	0	20.63	20.56	20.70	20.82	20.80	3		
		1	0	21.75	21.63	21.82	21.86	21.84	5		
		1	12	21.61	21.56	21.73	21.91	21.79	5		
		1	24	21.51	21.44	21.59	21.71	21.61	5		
5M	256QAM	12	0	20.66	20.65	20.66	20.85	20.82	5		
		12	6	20.75	20.56	20.73	20.85	20.71	5		
		12	13	20.77	20.61	20.79	20.82	20.90	5		
		25	0	20.68	20.63	20.72	20.76	20.83	5		



LTE Conducted Power (Full)								
LTE Band 48								
BW	MCS Index	RB Size	RB Offset	Low	Mid	Mid	Mid	3GPP MPR (dB)
		Channel		55340	55780	56210	56640	
		Frequency (MHz)		3560	3603	3647	3690	
20M	QPSK	1	0	21.47	21.29	21.63	21.85	0
		1	50	21.41	21.27	21.58	21.83	0
		1	99	21.39	21.25	21.55	21.81	0
		50	0	20.68	20.61	20.86	20.93	1
		50	25	20.67	20.58	20.83	20.89	1
		50	50	20.65	20.53	20.81	20.88	1
		100	0	20.72	20.56	20.82	20.87	1
20M	16QAM	1	0	20.29	20.31	20.76	20.92	1
		1	50	20.43	20.33	20.79	20.91	1
		1	99	20.47	20.25	20.78	20.89	1
		50	0	19.71	19.54	19.93	19.95	2
		50	25	19.69	19.53	19.83	18.94	2
		50	50	19.75	19.51	19.88	19.91	2
		100	0	19.74	19.59	19.80	19.89	2
20M	64QAM	1	0	19.37	19.29	19.80	19.44	2
		1	50	19.37	19.29	19.74	19.43	2
		1	99	19.47	19.27	19.78	19.41	2
		50	0	18.71	18.55	18.93	18.86	3
		50	25	18.67	18.51	18.82	18.85	3
		50	50	18.70	18.50	18.88	18.84	3
		100	0	18.68	18.58	18.79	18.83	3
20M	256QAM	1	0	16.39	16.39	16.45	16.53	5
		1	50	16.46	16.36	16.53	16.61	5
		1	99	16.40	16.31	16.45	16.51	5
		50	0	16.80	16.71	16.83	16.84	5
		50	25	16.83	16.81	16.83	16.83	5
		50	50	16.70	16.66	16.79	16.82	5
		100	0	16.78	16.75	16.80	16.81	5
BW	MCS Index	Channel		55315	55765	56215	56665	3GPP MPR
		Frequency (MHz)		3557.5	3602.5	3647.5	3692.5	
15M	QPSK	1	0	21.45	21.21	21.60	21.83	0
		1	37	21.33	21.24	21.53	21.78	0
		1	74	21.38	21.24	21.50	21.74	0
		36	0	20.59	20.52	20.77	20.83	1
		36	19	20.58	20.50	20.73	20.81	1
		36	39	20.58	20.46	20.74	20.82	1
		75	0	20.67	20.55	20.72	20.84	1
15M	16QAM	1	0	20.38	20.21	20.54	20.85	1
		1	37	20.37	20.26	20.48	20.74	1
		1	74	20.29	20.24	20.49	20.80	1
		36	0	19.65	19.58	19.83	19.86	2
		36	19	19.66	19.49	19.73	19.89	2
		36	39	19.65	19.51	19.80	19.84	2
		75	0	19.62	19.52	19.79	19.84	2
15M	64QAM	1	0	19.39	19.25	19.54	19.84	2
		1	37	19.33	19.21	19.57	19.80	2
		1	74	19.31	19.18	19.47	19.71	2
		36	0	18.66	18.52	18.80	18.83	3
		36	19	18.62	18.49	18.74	18.83	3
		36	39	18.64	18.53	18.73	18.86	3
		75	0	18.69	18.47	18.75	18.86	3
15M	256QAM	1	0	16.30	16.29	16.45	16.51	5
		1	37	16.42	16.36	16.52	16.60	5
		1	74	16.40	16.23	16.41	16.47	5
		36	0	16.80	16.61	16.81	16.75	5
		36	19	16.77	16.72	16.78	16.76	5
		36	39	16.64	16.60	16.69	16.78	5
		75	0	16.73	16.73	16.73	16.75	5

LTE Conducted Power (Full)								
LTE Band 48								
BW	MCS Index	Channel		55290	55750	56220	56690	3GPP MPR
		Frequency (MHz)		3555	3601	3648	3695	
10M	QPSK	1	0	21.39	21.14	21.60	21.76	0
		1	24	21.30	21.24	21.50	21.69	0
		1	49	21.24	21.16	21.37	21.76	0
		25	0	20.59	20.47	20.79	20.84	1
		25	12	20.50	20.47	20.81	20.80	1
		25	25	20.54	20.47	20.72	20.78	1
		50	0	20.67	20.45	20.67	20.79	1
10M	16QAM	1	0	20.39	20.23	20.55	20.77	1
		1	24	20.28	20.24	20.50	20.68	1
		1	49	20.33	20.09	20.44	20.78	1
		25	0	19.59	19.46	19.82	19.89	2
		25	12	19.56	19.45	19.76	19.85	2
		25	25	19.51	19.49	19.71	19.82	2
		50	0	19.60	19.52	19.72	19.81	2
10M	64QAM	1	0	19.35	19.18	19.56	19.80	2
		1	24	19.27	19.24	19.54	19.76	2
		1	49	19.28	19.06	19.40	19.70	2
		25	0	18.61	18.50	18.77	18.86	3
		25	12	18.50	18.44	18.79	18.79	3
		25	25	18.56	18.44	18.74	18.78	3
		50	0	18.69	18.52	18.76	18.81	3
10M	256QAM	1	0	16.35	16.30	16.32	16.38	5
		1	24	16.27	16.27	16.45	16.55	5
		1	49	16.29	16.22	16.36	16.49	5
		25	0	16.72	16.66	16.76	16.77	5
		25	12	16.72	16.78	16.75	16.80	5
		25	25	16.66	16.58	16.63	16.66	5
		50	0	16.75	16.69	16.68	16.66	5
BW	MCS Index	Channel		55265	55745	56235	56715	3GPP MPR
		Frequency (MHz)		3552.5	3600.5	3649.5	3697.5	
5M	QPSK	1	0	21.38	21.20	21.50	21.80	0
		1	12	21.30	21.13	21.39	21.68	0
		1	24	21.27	21.09	21.51	21.72	0
		12	0	20.56	20.49	20.70	20.77	1
		12	6	20.58	20.48	20.77	20.84	1
		12	13	20.50	20.43	20.69	20.73	1
		25	0	20.70	20.44	20.62	20.80	1
5M	16QAM	1	0	20.42	20.23	20.56	20.84	1
		1	12	20.26	20.17	20.45	20.72	1
		1	24	20.24	20.12	20.43	20.65	1
		12	0	19.56	19.48	19.79	19.81	2
		12	6	19.51	19.44	19.75	19.87	2
		12	13	19.46	19.45	19.67	19.76	2
		25	0	19.66	19.42	19.67	19.82	2
5M	64QAM	1	0	19.41	19.20	19.47	19.77	2
		1	12	19.24	19.15	19.38	19.64	2
		1	24	19.21	19.13	19.47	19.70	2
		12	0	18.61	18.51	18.79	18.77	3
		12	6	18.57	18.47	18.75	18.84	3
		12	13	18.56	18.42	18.71	18.75	3
		25	0	18.69	18.39	18.66	18.84	3
5M	256QAM	1	0	16.24	16.32	16.30	16.41	5
		1	12	16.36	16.18	16.43	16.50	5
		1	24	16.31	16.18	16.31	16.50	5
		12	0	16.65	16.66	16.76	16.71	5
		12	6	16.74	16.76	16.66	16.72	5
		12	13	16.60	16.58	16.67	16.77	5
		25	0	16.66	16.59	16.77	16.65	5

LTE Conducted Power (Full)							
LTE Band 66							
BW	MCS Index	RB Size	RB Offset	Low	Mid	High	3GPP MPR (dB)
		Channel		132072	132322	132572	
		Frequency (MHz)		1720	1745	1770	
20M	QPSK	1	0	23.15	23.26	23.18	0
		1	50	23.11	23.25	23.16	0
		1	99	23.09	23.18	23.15	0
		50	0	22.28	22.35	22.30	1
		50	25	22.12	22.31	22.22	1
		50	50	22.14	22.23	22.22	1
		100	0	22.24	22.31	22.29	1
20M	16QAM	1	0	22.43	22.56	22.49	1
		1	50	22.44	22.54	22.47	1
		1	99	22.37	22.51	22.46	1
		50	0	21.28	21.36	21.36	2
		50	25	21.25	21.33	21.31	2
		50	50	21.08	21.21	21.13	2
		100	0	21.14	21.24	21.16	2
20M	64QAM	1	0	21.31	21.43	21.38	2
		1	50	21.19	21.32	21.26	2
		1	99	21.22	21.41	21.31	2
		50	0	20.14	20.25	20.19	3
		50	25	20.24	20.35	20.33	3
		50	50	20.05	20.21	20.12	3
		100	0	20.10	20.22	20.19	3
20M	256QAM	1	0	18.17	18.33	18.27	5
		1	50	18.36	18.36	18.36	5
		1	99	18.16	18.27	18.19	5
		50	0	18.26	18.33	18.26	5
		50	25	18.21	18.34	18.27	5
		50	50	18.08	18.14	18.09	5
		100	0	18.22	18.23	18.23	5
BW	MCS Index	Channel		132047	132322	132597	3GPP MPR
Frequency (MHz)		1717.5	1745	1772.5			
15M	QPSK	1	0	23.13	23.21	23.18	0
		1	37	23.03	23.24	23.07	0
		1	74	23.07	23.08	23.06	0
		36	0	22.19	22.30	22.20	1
		36	19	22.02	22.30	22.19	1
		36	39	22.10	22.20	22.22	1
		75	0	22.19	22.30	22.29	1
15M	16QAM	1	0	22.34	22.48	22.45	1
		1	37	22.36	22.44	22.43	1
		1	74	22.29	22.50	22.37	1
		36	0	21.20	21.28	21.34	2
		36	19	21.17	21.31	21.23	2
		36	39	21.03	21.11	21.10	2
		75	0	21.04	21.20	21.12	2
15M	64QAM	1	0	21.24	21.34	21.28	2
		1	37	21.16	21.24	21.18	2
		1	74	21.22	21.33	21.23	2
		36	0	20.11	20.15	20.16	3
		36	19	20.24	20.26	20.31	3
		36	39	20.00	20.12	20.03	3
		75	0	20.09	20.15	20.14	3
15M	256QAM	1	0	18.14	18.30	18.05	5
		1	37	18.25	18.35	18.24	5
		1	74	18.00	18.08	18.11	5
		36	0	18.21	18.10	18.13	5
		36	19	18.17	18.18	18.08	5
		36	39	18.00	18.05	17.93	5
		75	0	18.10	18.11	18.14	5

LTE Conducted Power (Full)							
LTE Band 66							
BW	MCS Index	Channel		132022	132322	132622	3GPP MPR
		Frequency (MHz)		1715	1745	1775	
10M	QPSK	1	0	23.10	23.21	23.13	0
		1	24	23.00	23.12	23.02	0
		1	49	22.95	23.07	22.99	0
		25	0	22.07	22.27	22.14	1
		25	12	21.87	22.16	22.18	1
		25	25	22.07	22.18	22.08	1
		50	0	22.13	22.26	22.23	1
10M	16QAM	1	0	22.34	22.47	22.39	1
		1	24	22.23	22.41	22.39	1
		1	49	22.17	22.42	22.25	1
		25	0	21.05	21.25	21.32	2
		25	12	21.07	21.17	21.21	2
		25	25	21.03	21.00	21.07	2
		50	0	20.90	21.10	21.04	2
10M	64QAM	1	0	21.16	21.22	21.22	2
		1	24	21.05	21.14	21.14	2
		1	49	21.18	21.29	21.11	2
		25	0	20.07	20.01	20.10	3
		25	12	20.23	20.15	20.19	3
		25	25	19.91	20.09	19.91	3
		50	0	20.07	20.06	20.00	3
10M	256QAM	1	0	18.08	18.19	18.05	5
		1	24	18.18	18.31	18.20	5
		1	49	17.98	18.26	18.01	5
		25	0	18.06	18.17	18.18	5
		25	12	18.07	18.34	18.11	5
		25	25	17.92	17.94	17.94	5
		50	0	17.99	18.18	18.06	5
BW	MCS Index	Channel		131997	132322	132647	3GPP MPR
		Frequency (MHz)		1712.5	1745	1777.5	
5M	QPSK	1	0	23.01	23.06	22.98	0
		1	12	23.01	23.15	22.99	0
		1	24	23.06	23.08	22.86	0
		12	0	22.05	22.16	22.12	1
		12	6	21.93	22.19	22.10	1
		12	13	22.07	22.12	22.08	1
		25	0	22.12	22.19	22.12	1
5M	16QAM	1	0	22.28	22.34	22.38	1
		1	12	22.34	22.31	22.39	1
		1	24	22.15	22.38	22.23	1
		12	0	21.09	21.17	21.27	2
		12	6	21.16	21.22	21.17	2
		12	13	20.99	21.05	21.04	2
		25	0	20.90	21.11	21.05	2
5M	64QAM	1	0	21.16	21.29	21.24	2
		1	12	21.07	21.09	21.03	2
		1	24	21.17	21.26	21.12	2
		12	0	20.08	20.07	20.01	3
		12	6	20.14	20.13	20.27	3
		12	13	19.92	20.06	19.88	3
		25	0	19.97	20.10	20.06	3
5M	256QAM	1	0	18.06	18.15	18.14	5
		1	12	18.18	18.17	18.27	5
		1	24	18.14	18.15	18.03	5
		12	0	18.11	18.15	18.10	5
		12	6	18.11	18.20	18.08	5
		12	13	17.87	18.02	17.98	5
		25	0	18.07	18.07	18.10	5

LTE Conducted Power (Full)							
LTE Band 66							
BW	MCS Index	Channel		131987	132322	132657	3GPP MPR
		Frequency (MHz)		1711.5	1745	1778.5	
3M	QPSK	1	0	23.03	23.12	23.18	0
		1	7	22.89	23.23	22.96	0
		1	14	22.94	23.02	22.91	0
		8	0	22.16	22.30	22.18	1
		8	3	21.91	22.30	22.08	1
		8	7	22.02	22.13	22.10	1
		15	0	22.07	22.19	22.20	1
3M	16QAM	1	0	22.25	22.48	22.36	1
		1	7	22.28	22.34	22.29	1
		1	14	22.20	22.39	22.23	1
		8	0	21.17	21.28	21.22	2
		8	3	21.03	21.20	21.12	2
		8	7	20.93	21.08	21.00	2
		15	0	20.93	21.05	21.00	2
3M	64QAM	1	0	21.20	21.31	21.19	2
		1	7	21.12	21.19	21.12	2
		1	14	21.07	21.20	21.21	2
		8	0	20.03	20.06	20.07	3
		8	3	20.20	20.18	20.26	3
		8	7	19.87	20.12	19.95	3
		15	0	19.95	20.13	20.01	3
3M	256QAM	1	0	18.10	18.24	18.21	5
		1	7	18.27	18.16	18.29	5
		1	14	18.00	18.12	18.04	5
		8	0	18.08	18.17	18.16	5
		8	3	18.17	18.18	18.17	5
		8	7	17.92	18.01	17.94	5
		15	0	18.02	18.17	18.02	5
BW	MCS Index	Channel		131979	132322	132665	3GPP MPR
		Frequency (MHz)		1710.7	1745	1779.3	
1.4M	QPSK	1	0	23.11	23.14	23.16	0
		1	2	22.88	23.14	22.97	0
		1	5	22.96	22.93	22.98	0
		3	0	23.14	23.21	23.16	0
		3	1	22.87	23.22	23.09	0
		3	3	23.08	23.20	23.08	0
		6	0	22.05	22.24	22.24	1
1.4M	16QAM	1	0	22.26	22.41	22.36	1
		1	2	22.30	22.31	22.40	1
		1	5	22.29	22.41	22.27	1
		3	0	22.10	22.23	22.28	1
		3	1	22.17	22.18	22.17	1
		3	3	21.97	21.96	21.99	1
		6	0	21.03	21.10	21.03	2
1.4M	64QAM	1	0	21.13	21.33	21.18	2
		1	2	21.12	21.23	21.16	2
		1	5	21.20	21.25	21.13	2
		3	0	21.06	21.04	21.10	2
		3	1	21.15	21.15	21.17	2
		3	3	20.88	21.06	21.01	2
		6	0	20.07	20.02	20.13	3
1.4M	256QAM	1	0	18.01	18.29	18.06	5
		1	2	18.16	18.15	18.30	5
		1	5	17.95	18.24	18.06	5
		3	0	18.14	18.19	18.19	5
		3	1	18.11	18.23	18.17	5
		3	3	17.84	17.97	18.05	5
		6	0	18.06	18.20	18.21	5

LTE Conducted Power (Full)							
LTE Band 71							
BW	MCS Index	RB Size	RB Offset	Low	Mid	Mid	3GPP MPR (dB)
		Channel		133222	133297	133372	
		Frequency (MHz)		673	680.5	688	
20M	QPSK	1	0	23.61	23.67	23.65	0
		1	50	23.58	23.62	23.57	0
		1	99	23.52	23.58	23.52	0
		50	0	22.76	22.79	22.71	1
		50	25	22.71	22.77	22.69	1
		50	50	22.59	22.65	22.65	1
		100	0	22.75	22.78	22.70	1
20M	16QAM	1	0	22.90	22.95	22.92	1
		1	50	22.88	22.91	22.89	1
		1	99	22.75	22.79	22.78	1
		50	0	21.82	21.85	21.84	2
		50	25	21.71	21.75	21.70	2
		50	50	21.68	21.71	21.65	2
		100	0	21.77	21.80	21.75	2
20M	64QAM	1	0	21.75	21.81	21.77	2
		1	50	21.72	21.75	21.66	2
		1	99	21.69	21.72	21.63	2
		50	0	20.81	20.84	20.81	3
		50	25	20.69	20.72	20.72	3
		50	50	20.65	20.69	20.61	3
		100	0	20.76	20.79	20.72	3
20M	256QAM	1	0	18.79	18.82	18.76	5
		1	50	18.68	18.72	18.66	5
		1	99	18.57	18.63	18.55	5
		50	0	18.54	18.59	18.50	5
		50	25	18.48	18.51	18.47	5
		50	50	18.39	18.44	18.39	5
		100	0	18.68	18.71	18.65	5
BW	MCS Index	Channel		133197	133297	133397	3GPP MPR
Frequency (MHz)		670.5	680.5	690.5			
15M	QPSK	1	0	23.57	23.65	23.62	0
		1	37	23.48	23.58	23.56	0
		1	74	23.46	23.52	23.49	0
		36	0	22.66	22.72	22.71	1
		36	19	22.71	22.70	22.68	1
		36	39	22.58	22.62	22.63	1
		75	0	22.70	22.70	22.61	1
15M	16QAM	1	0	22.80	22.91	22.87	1
		1	37	22.79	22.90	22.80	1
		1	74	22.63	22.76	22.68	1
		36	0	21.81	21.85	21.79	2
		36	19	21.66	21.66	21.62	2
		36	39	21.66	21.66	21.63	2
		75	0	21.67	21.74	21.65	2
15M	64QAM	1	0	21.70	21.75	21.68	2
		1	37	21.59	21.67	21.60	2
		1	74	21.61	21.69	21.56	2
		36	0	20.76	20.75	20.74	3
		36	19	20.59	20.63	20.64	3
		36	39	20.64	20.60	20.60	3
		75	0	20.69	20.69	20.72	3
15M	256QAM	1	0	18.75	18.78	18.70	5
		1	37	18.58	18.71	18.57	5
		1	74	18.48	18.53	18.50	5
		36	0	18.47	18.50	18.44	5
		36	19	18.45	18.44	18.38	5
		36	39	18.37	18.40	18.36	5
		75	0	18.59	18.63	18.63	5

LTE Conducted Power (Full)									
LTE Band 71									
BW	MCS Index	Channel		133172	133297	133422	3GPP MPR		
		Frequency (MHz)		668	680.5	693			
10M	QPSK	1	0	23.41	23.51	23.62	0		
		1	24	23.41	23.47	23.34	0		
		1	49	23.38	23.43	23.50	0		
		25	0	22.52	22.66	22.69	1		
		25	12	22.53	22.55	22.59	1		
		25	25	22.56	22.57	22.60	1		
10M	16QAM	50	0	22.65	22.72	22.63	1		
		1	0	22.77	22.84	22.89	1		
		1	24	22.81	22.76	22.76	1		
		1	49	22.56	22.69	22.67	1		
		25	0	21.73	21.67	21.77	2		
		25	12	21.63	21.73	21.60	2		
10M	64QAM	25	25	21.57	21.61	21.45	2		
		50	0	21.64	21.69	21.65	2		
		1	0	21.71	21.78	21.67	2		
		1	24	21.52	21.74	21.54	2		
		1	49	21.58	21.60	21.57	2		
		25	0	20.72	20.69	20.65	3		
10M	256QAM	25	12	20.58	20.69	20.56	3		
		25	25	20.53	20.56	20.39	3		
		50	0	20.57	20.64	20.51	3		
		1	0	18.75	18.78	18.70	5		
		1	24	18.58	18.71	18.57	5		
		1	49	18.48	18.53	18.50	5		
10M	256QAM	25	0	18.47	18.50	18.44	5		
		25	12	18.45	18.44	18.38	5		
		25	25	18.37	18.40	18.36	5		
		50	0	18.59	18.63	18.63	5		
		BW	MCS Index	Channel		133147	133297	133447	3GPP MPR
				Frequency (MHz)		665.5	680.5	695.5	
5M	QPSK	1	0	23.59	23.45	23.56	0		
		1	12	23.35	23.50	23.39	0		
		1	24	23.37	23.39	23.34	0		
		12	0	22.67	22.75	22.66	1		
		12	6	22.59	22.74	22.62	1		
		12	13	22.56	22.58	22.58	1		
5M	16QAM	25	0	22.53	22.70	22.66	1		
		1	0	22.69	22.89	22.82	1		
		1	12	22.78	22.73	22.81	1		
		1	24	22.68	22.72	22.65	1		
		12	0	21.73	21.74	21.62	2		
		12	6	21.56	21.58	21.60	2		
5M	64QAM	12	13	21.64	21.55	21.50	2		
		25	0	21.56	21.65	21.55	2		
		1	0	21.56	21.66	21.55	2		
		1	12	21.54	21.57	21.51	2		
		1	24	21.47	21.63	21.50	2		
		12	0	20.77	20.74	20.73	3		
5M	256QAM	12	6	20.62	20.61	20.58	3		
		12	13	20.52	20.59	20.43	3		
		25	0	20.60	20.62	20.66	3		
		1	0	18.70	18.82	18.74	5		
		1	12	18.63	18.66	18.64	5		
		1	24	18.50	18.55	18.50	5		
5M	256QAM	12	0	18.51	18.53	18.43	5		
		12	6	18.46	18.51	18.47	5		
		12	13	18.40	18.41	18.39	5		
		25	0	18.65	18.64	18.65	5		

## NR Conducted Power (Full)

### NR Band 2\_SA

BW	MCS Index	RB Size	RB Offset	Low	Mid	High	3GPP MPR (dB)
		Channel		372000	376000	380000	
		Frequency (MHz)		1860	1880	1900	
20M	DFT-S PI/2 BPSK	1	1	23.93	23.96	23.83	0
20M	DFT-S QPSK	1	1	23.95	23.98	23.86	0
		1	53	23.92	23.95	23.82	0
		1	104	23.91	23.92	23.87	0
		50	0	22.95	22.98	22.89	1
		50	28	23.91	23.96	23.81	0
		50	56	22.89	22.95	22.81	1
100	0	22.92	22.97	22.86	1		
20M	DFT-S 16QAM	1	1	22.87	22.95	22.80	1
20M	DFT-S 64QAM	1	1	21.17	21.18	21.15	2.5
20M	DFT-S 256QAM	1	1	19.39	19.43	19.39	4.5
20M	CP QPSK	1	1	22.48	22.48	22.47	1.5
BW	MCS Index	Channel		371500	376000	380500	3GPP MPR
		Frequency (MHz)		1857.5	1880	1902.5	
15M	DFT-S PI/2 BPSK	1	1	23.86	23.87	23.79	0
15M	DFT-S QPSK	1	1	23.93	23.93	23.82	0
		1	40	23.90	23.88	23.77	0
		1	77	23.85	23.83	23.83	0
		36	0	22.95	22.91	22.89	1
		36	22	23.88	23.91	23.81	0
		36	43	22.88	22.91	22.71	1
75	0	22.87	22.94	22.86	1		
15M	DFT-S 16QAM	1	1	22.80	22.90	22.72	1
15M	DFT-S 64QAM	1	1	21.07	21.14	21.11	2.5
15M	DFT-S 256QAM	1	1	19.29	19.41	19.32	4.5
15M	CP QPSK	1	1	22.43	22.39	22.45	1.5



## NR Conducted Power (Full)

### NR Band 2\_SA

BW	MCS Index	Channel		371000	376000	381000	3GPP MPR
		Frequency (MHz)		1855	1880	1905	
10M	DFT-S PI/2 BPSK	1	1	23.82	23.86	23.74	0
10M	DFT-S QPSK	1	1	23.87	23.84	23.72	0
		1	26	23.75	23.79	23.70	0
		1	50	23.75	23.79	23.70	0
		25	0	22.79	22.84	22.70	1
		25	14	23.78	23.78	23.65	0
		25	27	22.83	22.86	22.74	1
10M	DFT-S 16QAM	1	1	22.66	22.89	22.73	1
10M	DFT-S 64QAM	1	1	21.03	21.02	21.10	2.5
10M	DFT-S 256QAM	1	1	19.21	19.23	19.29	4.5
10M	CP QPSK	1	1	22.38	22.45	22.34	1.5
BW	MCS Index	Channel		370500	376000	381500	3GPP MPR
		Frequency (MHz)		1852.5	1880	1907.5	
5M	DFT-S PI/2 BPSK	1	1	23.83	23.84	23.72	0
5M	DFT-S QPSK	1	1	23.82	23.91	23.66	0
		1	13	23.71	23.84	23.63	0
		1	23	23.66	23.84	23.77	0
		12	0	22.83	22.89	22.71	1
		12	7	23.77	23.77	23.60	0
		12	13	22.80	22.91	22.66	1
5M	DFT-S 16QAM	1	1	22.74	22.71	22.74	1
5M	DFT-S 64QAM	1	1	21.10	21.15	21.00	2.5
5M	DFT-S 256QAM	1	1	19.24	19.36	19.21	4.5
5M	CP QPSK	1	1	22.40	22.37	22.36	1.5

## NR Conducted Power (Full)

### NR Band 5\_SA

BW	MCS Index	RB Size	RB Offset	Low	Mid	High	3GPP MPR (dB)
		Channel		166800	167300	167800	
		Frequency (MHz)		834	836.5	839	
20M	DFT-S PI/2 BPSK	1	1	22.89	23.08	22.98	0
20M	DFT-S QPSK	1	1	22.91	23.11	23.03	0
		1	53	22.98	23.08	23.02	0
		1	104	22.88	23.05	22.98	0
		50	0	22.10	22.18	22.14	1
		50	28	22.95	23.09	23.04	0
		50	56	22.34	22.38	22.35	1
100	0	22.25	22.33	22.29	1		
20M	DFT-S 16QAM	1	1	22.15	22.21	22.16	1
20M	DFT-S 64QAM	1	1	20.05	20.22	20.15	2.5
20M	DFT-S 256QAM	1	1	18.48	18.63	18.55	4.5
20M	CP QPSK	1	1	22.09	22.15	22.14	1.5
BW	MCS Index	Channel		166300	167300	168300	3GPP MPR
		Frequency (MHz)		831.5	836.5	841.5	
15M	DFT-S PI/2 BPSK	1	1	22.81	23.08	22.96	0
15M	DFT-S QPSK	1	1	22.86	23.08	22.95	0
		1	40	22.94	23.05	22.95	0
		1	77	22.81	22.98	22.93	0
		36	0	22.02	22.11	22.04	1
		36	22	22.90	22.99	22.99	0
		36	43	22.30	22.30	22.30	1
75	0	22.17	22.30	22.29	1		
15M	DFT-S 16QAM	1	1	22.09	22.19	22.14	1
15M	DFT-S 64QAM	1	1	20.01	20.21	20.14	2.5
15M	DFT-S 256QAM	1	1	18.47	18.57	18.55	4.5
15M	CP QPSK	1	1	22.07	22.08	22.10	1.5

## NR Conducted Power (Full)

### NR Band 5\_SA

BW	MCS Index	Channel		165800	167300	168800	3GPP MPR
		Frequency (MHz)		829	836.5	844	
10M	DFT-S PI/2 BPSK	1	1	22.81	23.03	22.75	0
10M	DFT-S QPSK	1	1	22.84	23.02	22.95	0
		1	26	22.86	22.95	22.88	0
		1	50	22.67	22.97	22.89	0
		25	0	21.93	22.11	21.98	1
		25	14	22.81	23.01	22.86	0
		25	27	22.25	22.31	22.27	1
10M	DFT-S 16QAM	1	1	22.14	22.03	22.08	1
10M	DFT-S 64QAM	1	1	19.99	20.11	20.09	2.5
10M	DFT-S 256QAM	1	1	18.26	18.42	18.41	4.5
10M	CP QPSK	1	1	22.00	22.02	21.96	1.5
BW	MCS Index	Channel		165300	167300	169300	3GPP MPR
		Frequency (MHz)		826.5	836.5	846.5	
5M	DFT-S PI/2 BPSK	1	1	22.86	22.95	22.72	0
5M	DFT-S QPSK	1	1	22.86	23.02	22.95	0
		1	13	22.85	22.90	22.80	0
		1	23	22.75	22.98	22.84	0
		12	0	21.98	22.13	21.99	1
		12	7	22.74	22.98	22.87	0
		12	13	22.30	22.18	22.14	1
5M	DFT-S 16QAM	1	1	22.12	22.08	22.01	1
5M	DFT-S 64QAM	1	1	19.87	20.08	20.00	2.5
5M	DFT-S 256QAM	1	1	18.26	18.61	18.44	4.5
5M	CP QPSK	1	1	21.96	22.00	21.96	1.5

**NR Conducted Power (Full)**

**NR Band 7\_SA**

BW	MCS Index	Channel		502000	507000	512000	3GPP MPR
		Frequency (MHz)		2510	2535	2560	
20M	DFT-S PI/2 BPSK	1	1	22.13	22.26	22.15	0
20M	DFT-S QPSK	1	1	22.34	22.47	22.36	0
		1	53	22.21	22.34	22.23	0
		1	104	22.20	22.33	22.22	0
		50	0	21.22	21.35	21.24	1
		50	28	22.21	22.34	22.23	0
		50	56	21.18	21.31	21.20	1
100	0	21.12	21.25	21.14	1		
20M	DFT-S 16QAM	1	1	21.11	21.24	21.13	1
20M	DFT-S 64QAM	1	1	19.82	19.95	19.84	2.5
20M	DFT-S 256QAM	1	1	18.02	18.15	18.04	4.5
20M	CP QPSK	1	1	21.18	21.31	21.20	1.5
BW	MCS Index	Channel		501500	507000	512500	3GPP MPR
		Frequency (MHz)		2507.5	2535	2562.5	
15M	DFT-S PI/2 BPSK	1	1	22.06	22.17	22.08	0
15M	DFT-S QPSK	1	1	22.33	22.45	22.32	0
		1	40	22.14	22.33	22.21	0
		1	77	22.14	22.28	22.18	0
		36	0	21.13	21.25	21.22	1
		36	22	22.11	22.25	22.22	0
		36	43	21.16	21.27	21.16	1
75	0	21.10	21.24	21.09	1		
15M	DFT-S 16QAM	1	1	21.03	21.18	21.04	1
15M	DFT-S 64QAM	1	1	19.80	19.88	19.74	2.5
15M	DFT-S 256QAM	1	1	17.92	18.07	18.03	4.5
15M	CP QPSK	1	1	21.12	21.23	21.12	1.5

## NR Conducted Power (Full)

### NR Band 7\_SA

BW	MCS Index	Channel		501000	507000	513000	3GPP MPR
		Frequency (MHz)		2505	2535	2565	
10M	DFT-S PI/2 BPSK	1	1	22.10	22.24	22.10	0
10M	DFT-S QPSK	1	1	22.29	22.38	22.27	0
		1	26	22.15	22.27	22.13	0
		1	50	22.19	22.25	22.16	0
		25	0	21.21	21.25	21.17	1
		25	14	22.18	22.30	22.22	0
		25	27	21.09	21.26	21.10	1
10M	DFT-S 16QAM	1	1	21.02	21.16	21.03	1
10M	DFT-S 64QAM	1	1	19.77	19.88	19.79	2.5
10M	DFT-S 256QAM	1	1	18.01	18.09	18.04	4.5
10M	CP QPSK	1	1	21.08	21.28	21.15	1.5
BW	MCS Index	Channel		500500	507000	513500	3GPP MPR
		Frequency (MHz)		2502.5	2535	2567.5	
5M	DFT-S PI/2 BPSK	1	1	22.04	22.24	22.15	0
5M	DFT-S QPSK	1	1	22.30	22.46	22.28	0
		1	13	22.16	22.25	22.18	0
		1	23	22.18	22.32	22.12	0
		12	0	21.20	21.26	21.20	1
		12	7	22.21	22.25	22.13	0
		12	13	21.11	21.27	21.15	1
5M	DFT-S 16QAM	1	1	21.11	21.16	21.07	1
5M	DFT-S 64QAM	1	1	19.72	19.86	19.79	2.5
5M	DFT-S 256QAM	1	1	17.99	18.12	18.01	4.5
5M	CP QPSK	1	1	21.18	21.30	21.14	1.5

## NR Conducted Power (Full)

### NR Band 25\_SA

BW	MCS Index	Channel		372000	376500	381000	3GPP MPR
		Frequency (MHz)		1860	1882.5	1905	
20M	DFT-S PI/2 BPSK	1	1	22.16	22.70	22.80	0
20M	DFT-S QPSK	1	1	22.37	22.91	23.01	0
		1	53	22.33	22.87	22.97	0
		1	104	22.08	22.62	22.72	0
		50	0	21.27	21.81	21.91	1
		50	28	22.23	22.77	22.87	0
		50	56	21.15	21.69	21.79	1
100	0	21.07	21.61	21.71	1		
20M	DFT-S 16QAM	1	1	21.16	21.70	21.80	1
20M	DFT-S 64QAM	1	1	19.87	20.41	20.51	2.5
20M	DFT-S 256QAM	1	1	18.07	18.61	18.71	4.5
20M	CP QPSK	1	1	21.23	21.77	21.87	1.5
BW	MCS Index	Channel		371500	376500	381500	3GPP MPR
		Frequency (MHz)		1857.5	1882.5	1907.5	
15M	DFT-S PI/2 BPSK	1	1	22.11	22.62	22.74	0
15M	DFT-S QPSK	1	1	22.33	22.88	22.98	0
		1	40	22.33	22.82	22.88	0
		1	77	22.01	22.60	22.69	0
		36	0	21.20	21.79	21.90	1
		36	22	22.13	22.74	22.77	0
		36	43	21.08	21.62	21.77	1
75	0	21.07	21.56	21.71	1		
15M	DFT-S 16QAM	1	1	21.11	21.67	21.77	1
15M	DFT-S 64QAM	1	1	19.82	20.37	20.42	2.5
15M	DFT-S 256QAM	1	1	18.02	18.52	18.61	4.5
15M	CP QPSK	1	1	21.16	21.67	21.87	1.5

**NR Conducted Power (Full)**

**NR Band 25\_SA**

BW	MCS Index	Channel		371000	376500	382000	3GPP MPR
		Frequency (MHz)		1855	1882.5	1910	
10M	DFT-S PI/2 BPSK	1	1	22.06	22.62	22.74	0
10M	DFT-S QPSK	1	1	22.34	22.91	22.93	0
		1	26	22.24	22.78	22.91	0
		1	50	22.06	22.57	22.71	0
		25	0	21.27	21.71	21.82	1
		25	14	22.16	22.75	22.78	0
		25	27	21.05	21.59	21.71	1
10M	DFT-S 16QAM	1	1	21.14	21.60	21.78	1
10M	DFT-S 64QAM	1	1	19.78	20.36	20.47	2.5
10M	DFT-S 256QAM	1	1	18.03	18.55	18.64	4.5
10M	CP QPSK	1	1	21.16	21.73	21.79	1.5
BW	MCS Index	Channel		370500	376500	382500	3GPP MPR
		Frequency (MHz)		1852.5	1882.5	1912.5	
5M	DFT-S PI/2 BPSK	1	1	22.11	22.63	22.76	0
5M	DFT-S QPSK	1	1	22.34	22.87	23.00	0
		1	13	22.30	22.84	22.96	0
		1	23	22.05	22.54	22.62	0
		12	0	21.23	21.72	21.89	1
		12	7	22.22	22.72	22.78	0
		12	13	21.13	21.63	21.70	1
5M	DFT-S 16QAM	1	1	21.13	21.69	21.75	1
5M	DFT-S 64QAM	1	1	19.79	20.40	20.46	2.5
5M	DFT-S 256QAM	1	1	18.05	18.53	18.71	4.5
5M	CP QPSK	1	1	21.22	21.70	21.79	1.5

## NR Conducted Power (Full)

### NR Band 30\_SA

BW	MCS Index	RB Size	RB Offset	Mid			3GPP MPR (dB)
		Channel		462000			
		Frequency (MHz)		2310			
10M	DFT-S PI/2 BPSK	1	1		22.66		0
10M	DFT-S QPSK	1	1		22.79		0
		1	26		22.67		0
		1	50		22.52		0
		25	0		21.37		1
		25	14		22.18		0
		25	27		21.11		1
		50	0		21.01		1
10M	DFT-S 16QAM	1	1		21.26		1
10M	DFT-S 64QAM	1	1		19.97		2.5
10M	DFT-S 256QAM	1	1		18.17		4.5
10M	CP QPSK	1	1		21.33		1.5
BW	MCS Index	Channel		461500	462000	462500	3GPP MPR
		Frequency (MHz)		2307.5	2310	2312.5	
5M	DFT-S PI/2 BPSK	1	1	22.65	22.59	22.60	0
5M	DFT-S QPSK	1	1	22.78	22.77	22.78	0
		1	13	22.64	22.65	22.60	0
		1	23	22.47	22.49	22.46	0
		12	0	21.34	21.32	21.31	1
		12	7	22.11	22.12	22.11	0
		12	13	21.11	21.08	21.08	1
		25	0	20.93	21.00	20.99	1
5M	DFT-S 16QAM	1	1	21.18	21.23	21.26	1
5M	DFT-S 64QAM	1	1	19.93	19.91	19.94	2.5
5M	DFT-S 256QAM	1	1	18.10	18.08	18.13	4.5
5M	CP QPSK	1	1	21.33	21.31	21.30	1.5



## NR Conducted Power (Full)

### NR Band 66\_SA

BW	MCS Index	RB Size	RB Offset	Low	Mid	High	3GPP MPR (dB)
		Channel		346000	349000	352000	
		Frequency (MHz)		1730	1745	1760	
40M	DFT-S PI/2 BPSK	1	1	23.47	23.76	23.68	0
40M	DFT-S QPSK	1	1	23.56	23.86	23.77	0
		1	108	23.53	23.75	23.66	0
		1	214	23.56	23.78	23.75	0
		108	0	22.15	22.36	22.28	1
		108	54	23.71	23.85	23.82	0
		108	108	22.50	22.58	22.55	1
		216	0	22.37	22.52	22.50	1
40M	DFT-S 16QAM	1	1	22.60	22.75	22.75	1
40M	DFT-S 64QAM	1	1	20.86	20.95	20.95	2.5
40M	DFT-S 256QAM	1	1	19.09	19.33	19.30	4.5
40M	CP QPSK	1	1	22.27	22.48	22.39	1.5
BW	MCS Index	Channel		345000	349000	353000	3GPP MPR
		Frequency (MHz)		1725	1745	1765	
30M	DFT-S PI/2 BPSK						
30M	DFT-S QPSK						
30M	DFT-S 16QAM						
30M	DFT-S 64QAM						
30M	DFT-S 256QAM						
30M	CP QPSK						

## NR Conducted Power (Full)

### NR Band 66\_SA

BW	MCS Index	Channel		344000	349000	354000	3GPP MPR
		Frequency (MHz)		1720	1745	1770	
20M	DFT-S PI/2 BPSK	1	1	23.40	23.68	23.66	0
20M	DFT-S QPSK	1	1	23.47	23.85	23.74	0
		1	53	23.50	23.69	23.61	0
		1	104	23.46	23.74	23.71	0
		50	0	22.15	22.30	22.24	1
		50	28	23.61	23.75	23.77	0
		50	56	22.40	22.54	22.51	1
100	0	22.36	22.46	22.45	1		
20M	DFT-S 16QAM	1	1	22.57	22.74	22.65	1
20M	DFT-S 64QAM	1	1	20.81	20.95	20.87	2.5
20M	DFT-S 256QAM	1	1	19.07	19.30	19.23	4.5
20M	CP QPSK	1	1	22.23	22.47	22.29	1.5
BW	MCS Index	Channel		343500	349000	354500	3GPP MPR
		Frequency (MHz)		1717.5	1745	1772.5	
15M	DFT-S PI/2 BPSK	1	1	23.27	23.65	23.56	0
15M	DFT-S QPSK	1	1	23.41	23.74	23.57	0
		1	40	23.37	23.55	23.63	0
		1	77	23.49	23.59	23.56	0
		36	0	22.06	22.28	22.12	1
		36	22	23.64	23.69	23.68	0
		36	43	22.41	22.46	22.37	1
75	0	22.23	22.35	22.26	1		
15M	DFT-S 16QAM	1	1	22.36	22.51	22.72	1
15M	DFT-S 64QAM	1	1	20.71	20.80	20.88	2.5
15M	DFT-S 256QAM	1	1	18.91	19.19	19.16	4.5
15M	CP QPSK	1	1	22.09	22.32	22.30	1.5

## NR Conducted Power (Full)

### NR Band 66\_SA

BW	MCS Index	Channel		343000	349000	355000	3GPP MPR
		Frequency (MHz)		1715	1745	1775	
10M	DFT-S PI/2 BPSK	1	1	23.31	23.60	23.41	0
10M	DFT-S QPSK	1	1	23.55	23.66	23.55	0
		1	26	23.47	23.66	23.40	0
		1	50	23.43	23.68	23.57	0
		25	0	22.08	22.18	22.06	1
		25	14	23.65	23.74	23.59	0
		25	27	22.37	22.54	22.37	1
10M	DFT-S 16QAM	1	1	22.47	22.57	22.59	1
10M	DFT-S 64QAM	1	1	20.74	20.88	20.91	2.5
10M	DFT-S 256QAM	1	1	19.04	19.13	19.20	4.5
10M	CP QPSK	1	1	22.10	22.36	22.18	1.5
BW	MCS Index	Channel		342500	349000	355500	3GPP MPR
		Frequency (MHz)		1712.5	1745	1777.5	
5M	DFT-S PI/2 BPSK	1	1	23.26	23.71	23.52	0
5M	DFT-S QPSK	1	1	23.45	23.77	23.64	0
		1	13	23.47	23.67	23.63	0
		1	23	23.53	23.67	23.59	0
		12	0	22.02	22.25	22.23	1
		12	7	23.53	23.69	23.78	0
		12	13	22.42	22.54	22.46	1
5M	DFT-S 16QAM	1	1	22.41	22.64	22.66	1
5M	DFT-S 64QAM	1	1	20.76	20.94	20.83	2.5
5M	DFT-S 256QAM	1	1	18.97	19.21	19.11	4.5
5M	CP QPSK	1	1	22.04	22.27	22.30	1.5

## NR Conducted Power (Full)

### NR Band 71\_SA

BW	MCS Index	RB Size	RB Offset	Low	Mid	High	3GPP MPR (dB)
		Channel		134600	136100	137600	
		Frequency (MHz)		673	680.5	688	
20M	DFT-S PI/2 BPSK	1	1	23.29	23.49	23.26	0
20M	DFT-S QPSK	1	1	23.41	23.61	23.38	0
		1	53	23.21	23.41	23.18	0
		1	104	23.08	23.28	23.05	0
		50	0	22.59	22.79	22.56	1
		50	28	23.24	23.44	23.21	0
		50	56	23.16	23.36	23.13	1
		100	0	22.33	22.53	22.30	1
20M	DFT-S 16QAM	1	1	22.44	22.64	22.41	1
20M	DFT-S 64QAM	1	1	20.39	20.59	20.36	2.5
20M	DFT-S 256QAM	1	1	18.29	18.49	18.26	4.5
20M	CP QPSK	1	1	21.39	21.59	21.36	1.5
BW	MCS Index	Channel		134100	136100	138100	3GPP MPR
		Frequency (MHz)		670.5	680.5	690.5	
15M	DFT-S PI/2 BPSK	1	1	23.25	23.43	23.20	0
15M	DFT-S QPSK	1	1	23.33	23.51	23.29	0
		1	40	23.11	23.40	23.09	0
		1	77	23.07	23.25	23.05	0
		36	0	22.52	22.79	22.54	1
		36	22	23.16	23.41	23.19	0
		36	43	23.15	23.34	23.04	1
		75	0	22.30	22.51	22.23	1
15M	DFT-S 16QAM	1	1	22.34	22.56	22.35	1
15M	DFT-S 64QAM	1	1	20.37	20.50	20.32	2.5
15M	DFT-S 256QAM	1	1	18.22	18.46	18.21	4.5
15M	CP QPSK	1	1	21.30	21.49	21.28	1.5

**NR Conducted Power (Full)**

**NR Band 71\_SA**

BW	MCS Index	Channel		133600	136100	138600	3GPP MPR
		Frequency (MHz)		668	680.5	693	
10M	DFT-S PI/2 BPSK	1	1	23.24	23.46	23.18	0
10M	DFT-S QPSK	1	1	23.40	23.60	23.35	0
		1	26	23.19	23.38	23.11	0
		1	50	23.01	23.18	23.02	0
		25	0	22.52	22.77	22.56	1
		25	14	23.20	23.35	23.14	0
		25	27	23.16	23.36	23.03	1
10M	DFT-S 16QAM	1	1	22.44	22.62	22.35	1
10M	DFT-S 64QAM	1	1	20.30	20.49	20.27	2.5
10M	DFT-S 256QAM	1	1	18.20	18.43	18.20	4.5
10M	CP QPSK	1	1	21.39	21.49	21.36	1.5
BW	MCS Index	Channel		133100	136100	139100	3GPP MPR
		Frequency (MHz)		665.5	680.5	695.5	
5M	DFT-S PI/2 BPSK	1	1	23.28	23.45	23.26	0
5M	DFT-S QPSK	1	1	23.36	23.57	23.36	0
		1	13	23.11	23.40	23.14	0
		1	23	23.00	23.18	22.98	0
		12	0	22.54	22.74	22.50	1
		12	7	23.20	23.41	23.14	0
		12	13	23.16	23.31	23.05	1
5M	DFT-S 16QAM	1	1	22.42	22.64	22.35	1
5M	DFT-S 64QAM	1	1	20.30	20.53	20.27	2.5
5M	DFT-S 256QAM	1	1	18.23	18.43	18.25	4.5
5M	CP QPSK	1	1	21.38	21.53	21.26	1.5

NR Conducted Power (Full)							
NR Band 38_SA							
BW	MCS Index	Channel		516000	519000	522000	3GPP MPR
		Frequency (MHz)		2580	2595	2610	
20M	DFT-S PI/2 BPSK	1	1	23.20	23.21	23.19	0
20M	DFT-S QPSK	1	1	23.32	23.33	23.31	0
		1	26	23.29	23.30	23.27	0
		1	49	23.20	23.21	23.18	0
		25	0	22.37	22.38	22.35	1
		25	13	23.17	23.18	23.15	0
		25	26	22.30	22.31	22.28	1
20M	DFT-S 16QAM	1	1	22.22	22.23	22.20	1
20M	DFT-S 64QAM	1	1	20.17	20.18	20.15	2.5
20M	DFT-S 256QAM	1	1	18.27	18.28	18.25	4.5
20M	CP QPSK	1	1	21.07	21.08	21.05	1.5
BW	MCS Index	Channel		515500	519000	522500	3GPP MPR
		Frequency (MHz)		2577.5	2595	2612.5	
15M	DFT-S PI/2 BPSK	1	1	23.10	23.20	23.18	0
15M	DFT-S QPSK	1	1	23.24	23.32	23.23	0
		1	19	23.22	23.22	23.18	0
		1	36	23.20	23.17	23.16	0
		18	0	22.37	22.29	22.31	1
		18	10	23.08	23.08	23.15	0
		18	20	22.28	22.24	22.18	1
15M	DFT-S 16QAM	1	1	22.16	22.16	22.12	1
15M	DFT-S 64QAM	1	1	20.08	20.17	20.09	2.5
15M	DFT-S 256QAM	1	1	18.20	18.27	18.16	4.5
15M	CP QPSK	1	1	21.00	21.00	20.96	1.5

NR Conducted Power (Full)							
NR Band 38_SA							
BW	MCS Index	Channel		515000	519000	523000	3GPP MPR
		Frequency (MHz)		2575	2595	2615	
10M	DFT-S PI/2 BPSK	1	1	23.11	23.17	23.13	0
10M	DFT-S QPSK	1	1	23.26	23.28	23.27	0
		1	11	23.19	23.28	23.21	0
		1	22	23.14	23.14	23.09	0
		12	0	22.34	22.32	22.33	1
		12	6	23.11	23.12	23.13	0
		12	12	22.21	22.26	22.19	1
		24	0	22.22	22.20	22.22	1
10M	DFT-S 16QAM	1	1	22.19	22.22	22.17	1
10M	DFT-S 64QAM	1	1	20.12	20.09	20.11	2.5
10M	DFT-S 256QAM	1	1	18.23	18.28	18.17	4.5
10M	CP QPSK	1	1	20.99	21.04	21.01	1.5

NR Conducted Power (Full)							
NR Band 40_SA							
BW	MCS Index	Channel		468000	470000	472000	3GPP MPR
		Frequency (MHz)		2340	2350	2360	
80M	DFT-S PI/2 BPSK	1	1	23.40	23.50	23.49	0
80M	DFT-S QPSK	1	1	23.65	23.69	23.59	0
		1	109	23.41	23.51	23.43	0
		1	215	22.42	22.47	22.39	0
		108	0	22.80	22.83	22.83	1
		108	55	23.55	23.57	23.52	0
		108	109	22.49	22.58	22.49	1
80M	DFT-S 16QAM	1	1	22.64	22.68	22.67	1
80M	DFT-S 64QAM	1	1	20.47	20.53	20.45	2.5
80M	DFT-S 256QAM	1	1	18.53	18.63	18.58	4.5
80M	CP QPSK	1	1	22.10	22.13	22.09	1.5
BW	MCS Index	Channel		466000	470000	474000	3GPP MPR
		Frequency (MHz)		2330	2350	2370	
60M	DFT-S PI/2 BPSK	1	1	23.40	23.46	23.49	0
60M	DFT-S QPSK	1	1	23.65	23.66	23.65	0
		1	81	23.48	23.50	23.47	0
		1	160	22.45	22.44	22.47	0
		81	0	22.73	22.82	22.77	1
		81	41	23.47	23.47	23.48	0
		81	81	22.51	22.49	22.49	1
60M	DFT-S 16QAM	1	1	22.66	22.59	22.60	1
60M	DFT-S 64QAM	1	1	20.49	20.47	20.44	2.5
60M	DFT-S 256QAM	1	1	18.57	18.61	18.63	4.5
60M	CP QPSK	1	1	22.07	22.09	22.12	1.5



NR Conducted Power (Full)							
NR Band 40_SA							
BW	MCS Index	Channel		465000	470000	475000	3GPP MPR
		Frequency (MHz)		2325	2350	2375	
50M	DFT-S PI/2 BPSK	1	1	23.40	23.49	23.40	0
50M	DFT-S QPSK	1	1	23.67	23.58	23.65	0
		1	67	23.41	23.43	23.42	0
		1	131	22.37	22.40	22.43	0
		64	0	22.74	22.79	22.79	1
		64	35	23.49	23.48	23.48	0
		64	69	22.49	22.51	22.51	1
50M	DFT-S 16QAM	1	1	22.62	22.64	22.64	1
50M	DFT-S 64QAM	1	1	20.45	20.46	20.47	2.5
50M	DFT-S 256QAM	1	1	18.63	18.55	18.62	4.5
50M	CP QPSK	1	1	22.04	22.12	22.11	1.5
BW	MCS Index	Channel		464000	470000	476000	3GPP MPR
		Frequency (MHz)		2320	2350	2380	
40M	DFT-S PI/2 BPSK	1	1	23.42	23.47	23.50	0
40M	DFT-S QPSK	1	1	23.57	23.61	23.64	0
		1	53	23.46	23.45	23.46	0
		1	104	22.43	22.43	22.37	0
		50	0	22.77	22.83	22.73	1
		50	28	23.56	23.54	23.52	0
		50	56	22.50	22.51	22.52	1
40M	DFT-S 16QAM	1	1	22.63	22.64	22.66	1
40M	DFT-S 64QAM	1	1	20.43	20.52	20.50	2.5
40M	DFT-S 256QAM	1	1	18.59	18.63	18.59	4.5
40M	CP QPSK	1	1	22.09	22.10	22.03	1.5

NR Conducted Power (Full)							
NR Band 40_SA							
BW	MCS Index	Channel		462000	470000	478000	3GPP MPR
		Frequency (MHz)		2310	2350	2390	
20M	DFT-S PI/2 BPSK	1	1	23.42	23.44	23.47	0
20M	DFT-S QPSK	1	1	23.63	23.62	23.63	0
		1	26	23.46	23.41	23.45	0
		1	49	22.40	22.46	22.42	0
		25	0	22.77	22.82	22.77	1
		25	13	23.54	23.55	23.52	0
		25	26	22.57	22.52	22.55	1
		50	0	22.49	22.53	22.54	1
20M	DFT-S 16QAM	1	1	22.64	22.63	22.59	1
20M	DFT-S 64QAM	1	1	20.49	20.45	20.45	2.5
20M	DFT-S 256QAM	1	1	18.60	18.60	18.56	4.5
20M	CP QPSK	1	1	22.13	22.04	22.04	1.5
BW	MCS Index	Channel		461500	470000	478500	3GPP MPR
		Frequency (MHz)		2307.5	2350	2392.5	
15M	DFT-S PI/2 BPSK	1	1	23.50	23.50	23.44	0
15M	DFT-S QPSK	1	1	23.61	23.65	23.66	0
		1	19	23.43	23.44	23.49	0
		1	36	22.44	22.40	22.46	0
		18	0	22.83	22.78	22.83	1
		18	10	23.56	23.55	23.51	0
		18	20	22.54	22.55	22.56	1
		36	0	22.47	22.48	22.56	1
15M	DFT-S 16QAM	1	1	22.63	22.64	22.61	1
15M	DFT-S 64QAM	1	1	20.46	20.43	20.53	2.5
15M	DFT-S 256QAM	1	1	18.56	18.57	18.56	4.5
15M	CP QPSK	1	1	22.07	22.04	22.13	1.5

NR Conducted Power (Full)							
NR Band 40_SA							
BW	MCS Index	Channel		461000	470000	479000	3GPP MPR
		Frequency (MHz)		2305	2350	2395	
10M	DFT-S PI/2 BPSK	1	1	23.50	23.48	23.45	0
10M	DFT-S QPSK	1	1	23.58	23.58	23.67	0
		1	11	23.48	23.51	23.50	0
		1	22	22.38	22.37	22.44	0
		12	0	22.76	22.79	22.83	1
		12	6	23.51	23.50	23.49	0
		12	12	22.57	22.53	22.58	1
		24	0	22.53	22.46	22.50	1
10M	DFT-S 16QAM	1	1	22.68	22.66	22.65	1
10M	DFT-S 64QAM	1	1	20.45	20.51	20.46	2.5
10M	DFT-S 256QAM	1	1	18.63	18.61	18.58	4.5
10M	CP QPSK	1	1	22.09	22.06	22.07	1.5

NR Conducted Power (Full)									
NR Band 41_PC2_SA									
BW	MCS Index	RB Size	RB Offset	Low	Mid-1	Mid-2	Mid-3	High	3GPP MPR (dB)
		Channel		509202	513900	518598	523302	528000	
		Frequency (MHz)		2546.01	2569.5	2592.99	2616.51	2640	
100M	DFT-S PI/2 BPSK	1	1	26.60	26.62	26.65	26.58	26.61	0
100M	DFT-S QPSK	1	1	26.69	26.71	26.74	26.67	26.70	0
		1	137	26.50	26.52	26.55	26.48	26.51	0
		1	271	25.72	25.74	25.77	25.70	25.73	0
		135	0	25.71	25.73	25.76	25.69	25.72	1
		135	69	26.65	26.67	26.70	26.63	26.66	0
		135	138	25.67	25.69	25.72	25.65	25.68	1
270	0	25.66	25.68	25.71	25.64	25.67	1		
100M	DFT-S 16QAM	1	1	25.59	25.61	25.64	25.57	25.60	1
100M	DFT-S 64QAM	1	1	24.29	24.31	24.34	24.27	24.30	2.5
100M	DFT-S 256QAM	1	1	22.29	22.31	22.34	22.27	22.30	4.5
100M	CP QPSK	1	1	25.39	25.41	25.44	25.37	25.40	1.5
BW	MCS Index	Channel		508200	513402	518598	523800	528996	3GPP MPR
		Frequency (MHz)		2541	2567.01	2592.99	2619	2644.98	
90M	DFT-S PI/2 BPSK	1	1	26.58	26.56	26.56	26.58	26.59	0
90M	DFT-S QPSK	1	1	26.62	26.64	26.69	26.63	26.70	0
		1	123	26.49	26.46	26.47	26.50	26.49	0
		1	243	25.69	25.68	25.67	25.69	25.66	0
		120	0	25.69	25.68	25.75	25.63	25.68	1
		120	63	26.60	26.59	26.60	26.58	26.64	0
		120	125	25.59	25.59	25.62	25.64	25.61	1
243	0	25.59	25.62	25.61	25.58	25.60	1		
90M	DFT-S 16QAM	1	1	25.53	25.51	25.64	25.53	25.52	1
90M	DFT-S 64QAM	1	1	24.28	24.30	24.34	24.24	24.30	2.5
90M	DFT-S 256QAM	1	1	22.22	22.30	22.33	22.26	22.30	4.5
90M	CP QPSK	1	1	25.36	25.37	25.35	25.33	25.35	1.5

NR Conducted Power (Full)									
NR Band 41_PC2_SA									
BW	MCS Index	Channel		507204	509304	518598	500298	529998	3GPP MPR
		Frequency (MHz)		2536.02	2546.52	2592.99	2621.49	2649.99	
80M	DFT-S PI/2 BPSK	1	1	26.59	26.57	26.57	26.59	26.56	0
80M	DFT-S QPSK	1	1	26.69	26.69	26.73	26.65	26.62	0
		1	109	26.43	26.50	26.54	26.50	26.45	0
		1	215	25.64	25.66	25.69	25.72	25.64	0
		108	0	25.63	25.65	25.67	25.67	25.69	1
		108	55	26.61	26.60	26.62	26.57	26.60	0
		108	109	25.60	25.59	25.65	25.61	25.62	1
80M	DFT-S 16QAM	1	1	25.52	25.55	25.60	25.59	25.52	1
80M	DFT-S 64QAM	1	1	24.20	24.24	24.30	24.20	24.29	2.5
80M	DFT-S 256QAM	1	1	22.28	22.23	22.25	22.23	22.26	4.5
80M	CP QPSK	1	1	25.36	25.32	25.41	25.38	25.36	1.5
BW	MCS Index	Channel		506202	512400	518598	524802	531000	3GPP MPR
		Frequency (MHz)		2531.01	2562	2592.99	2624.01	2655	
70M	DFT-S PI/2 BPSK	1	1	26.53	26.55	26.57	26.51	26.62	0
70M	DFT-S QPSK	1	1	26.65	26.69	26.70	26.68	26.69	0
		1	95	26.42	26.52	26.46	26.50	26.42	0
		1	187	25.70	25.70	25.73	25.69	25.66	0
		90	0	25.67	25.65	25.67	25.70	25.64	1
		90	50	26.65	26.60	26.69	26.55	26.59	0
		90	99	25.59	25.66	25.71	25.58	25.66	1
70M	DFT-S 16QAM	1	1	25.52	25.59	25.56	25.53	25.60	1
70M	DFT-S 64QAM	1	1	24.28	24.26	24.26	24.28	24.31	2.5
70M	DFT-S 256QAM	1	1	22.19	22.22	22.24	22.22	22.21	4.5
70M	CP QPSK	1	1	25.36	25.41	25.43	25.29	25.41	1.5

NR Conducted Power (Full)									
NR Band 41_PC2_SA									
BW	MCS Index	Channel		505200	511896	518598	525294	531996	3GPP MPR
		Frequency (MHz)		2526	2559.48	2592.99	2626.48	2659.98	
60M	DFT-S PI/2 BPSK	1	1	26.53	26.56	26.62	26.51	26.58	0
60M	DFT-S QPSK	1	1	26.60	26.69	26.64	26.63	26.62	0
		1	81	26.50	26.50	26.52	26.49	26.48	0
		1	160	25.63	25.69	25.75	25.69	25.67	0
		81	0	25.71	25.67	25.73	25.67	25.66	1
		81	41	26.63	26.60	26.65	26.64	26.60	0
		81	81	25.64	25.60	25.65	25.66	25.66	1
60M	DFT-S 16QAM	1	1	25.49	25.59	25.64	25.55	25.59	1
60M	DFT-S 64QAM	1	1	24.20	24.26	24.25	24.28	24.22	2.5
60M	DFT-S 256QAM	1	1	22.28	22.22	22.26	22.26	22.31	4.5
60M	CP QPSK	1	1	25.34	25.36	25.37	25.31	25.38	1.5
BW	MCS Index	Channel		504204	511404	518598	525798	532998	3GPP MPR
		Frequency (MHz)		2521.02	2557.02	2592.99	2628.99	2664.99	
50M	DFT-S PI/2 BPSK	1	1	26.57	26.61	26.61	26.58	26.60	0
50M	DFT-S QPSK	1	1	26.66	26.64	26.64	26.68	26.63	0
		1	67	26.49	26.46	26.47	26.49	26.50	0
		1	131	25.65	25.66	25.76	25.69	25.72	0
		64	0	25.68	25.70	25.73	25.71	25.72	1
		64	35	26.56	26.58	26.70	26.60	26.57	0
		64	69	25.60	25.64	25.67	25.65	25.68	1
50M	DFT-S 16QAM	1	1	25.53	25.59	25.59	25.54	25.52	1
50M	DFT-S 64QAM	1	1	24.28	24.31	24.33	24.24	24.30	2.5
50M	DFT-S 256QAM	1	1	22.26	22.27	22.28	22.25	22.29	4.5
50M	CP QPSK	1	1	25.37	25.33	25.35	25.30	25.41	1.5

NR Conducted Power (Full)									
NR Band 41_PC2_SA									
BW	MCS Index	Channel		503202	510900	518598	526296	534000	3GPP MPR
		Frequency (MHz)		2516.01	2554.5	2592.99	2631.48	2670	
40M	DFT-S PI/2 BPSK	1	1	26.59	26.59	26.58	26.57	26.53	0
40M	DFT-S QPSK	1	1	26.59	26.63	26.68	26.62	26.70	0
		1	53	26.50	26.48	26.51	26.44	26.47	0
		1	104	25.63	25.74	25.68	25.72	25.66	0
		50	0	25.68	25.69	25.67	25.71	25.72	1
		50	28	26.63	26.58	26.69	26.57	26.67	0
		50	56	25.57	25.65	25.62	25.64	25.60	1
40M	DFT-S 16QAM	1	1	25.52	25.52	25.57	25.52	25.53	1
40M	DFT-S 64QAM	1	1	24.25	24.24	24.34	24.25	24.30	2.5
40M	DFT-S 256QAM	1	1	22.29	22.22	22.33	22.23	22.29	4.5
40M	CP QPSK	1	1	25.32	25.39	25.41	25.30	25.35	1.5
BW	MCS Index	Channel		502200	510396	518598	526794	534996	3GPP MPR
		Frequency (MHz)		2511	2551.98	2592.99	2633.97	2674.98	
30M	DFT-S PI/2 BPSK								
30M	DFT-S QPSK								
30M	DFT-S 16QAM								
30M	DFT-S 64QAM								
30M	DFT-S 256QAM								
30M	CP QPSK								

NR Conducted Power (Full)									
NR Band 41_PC2_SA									
BW	MCS Index	Channel		501204	509898	518598	527298	535998	3GPP MPR
		Frequency (MHz)		2506.02	2549.49	2592.99	2636.49	2679.99	
20M	DFT-S PI/2 BPSK	1	1	26.59	26.56	26.65	26.50	26.54	0
20M	DFT-S QPSK	1	1	26.60	26.64	26.66	26.67	26.71	0
		1	26	26.40	26.42	26.51	26.42	26.45	0
		1	49	25.71	25.67	25.75	25.71	25.70	0
		25	0	25.66	25.63	25.67	25.69	25.69	1
		25	13	26.65	26.62	26.63	26.61	26.67	0
		25	26	25.67	25.59	25.70	25.67	25.69	1
20M	DFT-S 16QAM	1	1	25.54	25.52	25.56	25.59	25.57	1
20M	DFT-S 64QAM	1	1	24.22	24.24	24.31	24.26	24.21	2.5
20M	DFT-S 256QAM	1	1	22.27	22.24	22.30	22.20	22.23	4.5
20M	CP QPSK	1	1	25.38	25.41	25.39	25.30	25.34	1.5
BW	MCS Index	Channel		500700	509646	518598	527544	536496	3GPP MPR
		Frequency (MHz)		2503.5	2548.23	2592.99	2637.72	2682.48	
15M	DFT-S PI/2 BPSK	1	1	26.58	26.59	26.64	26.51	26.60	0
15M	DFT-S QPSK	1	1	26.67	26.69	26.68	26.61	26.65	0
		1	19	26.43	26.44	26.53	26.44	26.42	0
		1	36	25.62	25.73	25.70	25.67	25.67	0
		18	0	25.66	25.64	25.73	25.63	25.63	1
		18	10	26.59	26.67	26.64	26.59	26.64	0
		18	20	25.59	25.61	25.65	25.65	25.65	1
15M	DFT-S 16QAM	1	1	25.56	25.61	25.56	25.55	25.54	1
15M	DFT-S 64QAM	1	1	24.19	24.28	24.25	24.24	24.31	2.5
15M	DFT-S 256QAM	1	1	22.29	22.23	22.30	22.23	22.29	4.5
15M	CP QPSK	1	1	25.39	25.35	25.37	25.29	25.41	1.5



NR Conducted Power (Full)									
NR Band 41_PC2_SA									
BW	MCS Index	Channel		500202	509400	518598	527796	537000	3GPP MPR
		Frequency (MHz)		2501.01	2547	2592.99	2638.98	2685	
10M	DFT-S PI/2 BPSK	1	1	26.50	26.53	26.60	26.55	26.58	0
10M	DFT-S QPSK	1	1	26.65	26.69	26.66	26.69	26.61	0
		1	11	26.40	26.48	26.50	26.45	26.48	0
		1	22	25.65	25.69	25.69	25.68	25.74	0
		12	0	25.69	25.72	25.72	25.68	25.68	1
		12	6	26.63	26.59	26.66	26.59	26.63	0
		12	12	25.62	25.64	25.70	25.58	25.67	1
		24	0	25.56	25.67	25.61	25.63	25.59	1
10M	DFT-S 16QAM	1	1	25.59	25.57	25.60	25.53	25.59	1
10M	DFT-S 64QAM	1	1	24.22	24.24	24.29	24.23	24.22	2.5
10M	DFT-S 256QAM	1	1	22.24	22.26	22.32	22.20	22.28	4.5
10M	CP QPSK	1	1	25.38	25.33	25.35	25.36	25.33	1.5

NR Conducted Power (Full)									
NR Band 41_PC3_SA									
BW	MCS Index	RB Size	RB Offset	Low	Mid-1	Mid-2	Mid-3	High	3GPP MPR (dB)
		Channel		509202	513900	518598	523302	528000	
		Frequency (MHz)		2546.01	2569.5	2592.99	2616.51	2640	
100M	DFT-S PI/2 BPSK	1	1	23.12	23.34	23.67	23.66	23.64	0
100M	DFT-S QPSK	1	1	23.27	23.49	23.82	23.81	23.79	0
		1	137	23.00	23.22	23.55	23.54	23.52	0
		1	271	22.22	22.44	22.77	22.76	22.74	0
		135	0	22.21	22.43	22.76	22.75	22.73	1
		135	69	23.15	23.37	23.70	23.69	23.67	0
		135	138	22.17	22.39	22.72	22.71	22.69	1
270	0	22.16	22.38	22.71	22.70	22.68	1		
100M	DFT-S 16QAM	1	1	22.10	22.32	22.65	22.64	22.62	1
100M	DFT-S 64QAM	1	1	20.01	20.23	20.56	20.55	20.53	2.5
100M	DFT-S 256QAM	1	1	17.91	18.13	18.46	18.45	18.43	4.5
100M	CP QPSK	1	1	22.08	22.30	22.63	22.62	22.60	1.5
BW	MCS Index	Channel		508200	513402	518598	523800	528996	3GPP MPR
		Frequency (MHz)		2541	2567.01	2592.99	2619	2644.98	
90M	DFT-S PI/2 BPSK	1	1	23.07	23.26	23.60	23.08	23.30	0
90M	DFT-S QPSK	1	1	23.20	23.46	23.72	23.22	23.39	0
		1	123	22.94	23.18	23.49	22.90	23.20	0
		1	243	22.14	22.39	22.71	22.22	22.34	0
		120	0	22.16	22.36	22.68	22.20	22.40	1
		120	63	23.10	23.28	23.61	23.09	23.30	0
		120	125	22.12	22.36	22.69	22.08	22.29	1
243	0	22.11	22.38	22.68	22.06	22.28	1		
90M	DFT-S 16QAM	1	1	22.08	22.31	22.60	22.08	22.32	1
90M	DFT-S 64QAM	1	1	19.94	20.15	20.52	20.00	20.16	2.5
90M	DFT-S 256QAM	1	1	17.87	18.06	18.38	17.90	18.09	4.5
90M	CP QPSK	1	1	22.05	22.29	22.53	22.08	22.27	1.5

NR Conducted Power (Full)									
NR Band 41_PC3_SA									
BW	MCS Index	Channel		507204	509304	518598	500298	529998	3GPP MPR
		Frequency (MHz)		2536.02	2546.52	2592.99	2621.49	2649.99	
80M	DFT-S PI/2 BPSK	1	1	23.08	23.24	23.57	23.11	23.25	0
80M	DFT-S QPSK	1	1	23.24	23.39	23.75	23.19	23.48	0
		1	109	22.92	23.19	23.55	22.97	23.14	0
		1	215	22.16	22.36	22.77	22.20	22.42	0
		108	0	22.20	22.39	22.67	22.19	22.35	1
		108	55	23.13	23.29	23.66	23.15	23.36	0
		108	109	22.16	22.38	22.72	22.08	22.33	1
80M	DFT-S 16QAM	1	1	22.09	22.23	22.65	22.00	22.29	1
80M	DFT-S 64QAM	1	1	19.97	20.23	20.49	19.93	20.21	2.5
80M	DFT-S 256QAM	1	1	17.87	18.10	18.44	17.81	18.12	4.5
80M	CP QPSK	1	1	22.06	22.26	22.63	22.02	22.24	1.5
BW	MCS Index	Channel		506202	512400	518598	524802	531000	3GPP MPR
		Frequency (MHz)		2531.01	2562	2592.99	2624.01	2655	
70M	DFT-S PI/2 BPSK	1	1	23.05	23.29	23.61	23.04	23.31	0
70M	DFT-S QPSK	1	1	23.21	23.43	23.75	23.22	23.42	0
		1	95	22.91	23.19	23.55	22.90	23.19	0
		1	187	22.22	22.43	22.71	22.15	22.36	0
		90	0	22.16	22.41	22.67	22.11	22.34	1
		90	50	23.07	23.32	23.68	23.11	23.35	0
		90	99	22.13	22.39	22.66	22.07	22.38	1
70M	DFT-S 16QAM	1	1	22.06	22.22	22.60	22.01	22.28	1
70M	DFT-S 64QAM	1	1	19.98	20.13	20.47	19.94	20.22	2.5
70M	DFT-S 256QAM	1	1	17.84	18.13	18.36	17.91	18.09	4.5
70M	CP QPSK	1	1	22.02	22.23	22.53	22.02	22.25	1.5

NR Conducted Power (Full)									
NR Band 41_PC3_SA									
BW	MCS Index	Channel		505200	511896	518598	525294	531996	3GPP MPR
		Frequency (MHz)		2526	2559.48	2592.99	2626.48	2659.98	
60M	DFT-S PI/2 BPSK	1	1	23.05	23.26	23.57	23.07	23.26	0
60M	DFT-S QPSK	1	1	23.23	23.41	23.74	23.20	23.48	0
		1	81	22.99	23.20	23.51	22.96	23.19	0
		1	160	22.16	22.40	22.77	22.15	22.34	0
		81	0	22.16	22.33	22.70	22.15	22.43	1
		81	41	23.11	23.36	23.69	23.08	23.31	0
		81	81	22.13	22.33	22.67	22.13	22.33	1
60M	DFT-S 16QAM	1	1	22.10	22.24	22.56	22.04	22.31	1
60M	DFT-S 64QAM	1	1	19.92	20.22	20.52	20.00	20.21	2.5
60M	DFT-S 256QAM	1	1	17.84	18.10	18.42	17.83	18.12	4.5
60M	CP QPSK	1	1	22.06	22.22	22.54	21.98	22.21	1.5
BW	MCS Index	Channel		504204	511404	518598	525798	532998	3GPP MPR
		Frequency (MHz)		2521.02	2557.02	2592.99	2628.99	2664.99	
50M	DFT-S PI/2 BPSK	1	1	23.05	23.27	23.64	23.05	23.25	0
50M	DFT-S QPSK	1	1	23.22	23.45	23.76	23.21	23.48	0
		1	67	22.92	23.13	23.50	22.90	23.20	0
		1	131	22.17	22.42	22.77	22.18	22.36	0
		64	0	22.11	22.38	22.66	22.11	22.40	1
		64	35	23.09	23.32	23.61	23.14	23.34	0
		64	69	22.17	22.34	22.71	22.13	22.32	1
50M	DFT-S 16QAM	1	1	22.08	22.27	22.58	22.02	22.32	1
50M	DFT-S 64QAM	1	1	19.93	20.14	20.46	19.99	20.17	2.5
50M	DFT-S 256QAM	1	1	17.89	18.04	18.36	17.81	18.11	4.5
50M	CP QPSK	1	1	22.02	22.28	22.62	22.03	22.23	1.5

NR Conducted Power (Full)									
NR Band 41_PC3_SA									
BW	MCS Index	Channel		503202	510900	518598	526296	534000	3GPP MPR
		Frequency (MHz)		2516.01	2554.5	2592.99	2631.48	2670	
40M	DFT-S PI/2 BPSK	1	1	23.10	23.32	23.62	23.10	23.33	0
40M	DFT-S QPSK	1	1	23.20	23.41	23.75	23.19	23.41	0
		1	53	22.92	23.21	23.48	22.91	23.20	0
		1	104	22.16	22.37	22.68	22.22	22.38	0
		50	0	22.21	22.36	22.69	22.21	22.43	1
		50	28	23.08	23.37	23.66	23.15	23.29	0
		50	56	22.11	22.36	22.72	22.12	22.33	1
40M	DFT-S 16QAM	1	1	22.02	22.27	22.62	22.10	22.22	1
40M	DFT-S 64QAM	1	1	19.97	20.16	20.55	19.93	20.20	2.5
40M	DFT-S 256QAM	1	1	17.90	18.08	18.41	17.91	18.10	4.5
40M	CP QPSK	1	1	22.01	22.25	22.54	22.00	22.26	1.5
BW	MCS Index	Channel		502200	510396	518598	526794	534996	3GPP MPR
		Frequency (MHz)		2511	2551.98	2592.99	2633.97	2674.98	
30M	DFT-S PI/2 BPSK								
30M	DFT-S QPSK								
30M	DFT-S 16QAM								
30M	DFT-S 64QAM								
30M	DFT-S 256QAM								
30M	CP QPSK								

NR Conducted Power (Full)									
NR Band 41_PC3_SA									
BW	MCS Index	Channel		501204	509898	518598	527298	535998	3GPP MPR
		Frequency (MHz)		2506.02	2549.49	2592.99	2636.49	2679.99	
20M	DFT-S PI/2 BPSK	1	1	23.05	23.32	23.60	23.07	23.30	0
20M	DFT-S QPSK	1	1	23.23	23.47	23.72	23.22	23.49	0
		1	26	22.95	23.22	23.51	22.90	23.19	0
		1	49	22.20	22.43	22.68	22.14	22.43	0
		25	0	22.16	22.33	22.70	22.16	22.33	1
		25	13	23.05	23.37	23.63	23.09	23.33	0
		25	26	22.16	22.38	22.64	22.17	22.34	1
20M	DFT-S 16QAM	1	1	22.04	22.30	22.56	22.08	22.28	1
20M	DFT-S 64QAM	1	1	20.01	20.17	20.53	19.93	20.21	2.5
20M	DFT-S 256QAM	1	1	17.82	18.09	18.37	17.85	18.13	4.5
20M	CP QPSK	1	1	22.04	22.27	22.54	22.01	22.28	1.5
BW	MCS Index	Channel		500700	509646	518598	527544	536496	3GPP MPR
		Frequency (MHz)		2503.5	2548.23	2592.99	2637.72	2682.48	
15M	DFT-S PI/2 BPSK	1	1	23.12	23.25	23.67	23.02	23.31	0
15M	DFT-S QPSK	1	1	23.17	23.45	23.74	23.24	23.48	0
		1	19	22.94	23.16	23.47	22.96	23.18	0
		1	36	22.21	22.35	22.77	22.19	22.43	0
		18	0	22.21	22.39	22.67	22.21	22.42	1
		18	10	23.13	23.29	23.68	23.05	23.28	0
		18	20	22.13	22.31	22.67	22.11	22.33	1
15M	DFT-S 16QAM	1	1	22.04	22.25	22.56	22.08	22.30	1
15M	DFT-S 64QAM	1	1	19.96	20.19	20.50	19.96	20.21	2.5
15M	DFT-S 256QAM	1	1	17.81	18.09	18.43	17.86	18.12	4.5
15M	CP QPSK	1	1	22.04	22.23	22.53	22.02	22.30	1.5

NR Conducted Power (Full)									
NR Band 41_PC3_SA									
BW	MCS Index	Channel		500202	509400	518598	527796	537000	3GPP MPR
		Frequency (MHz)		2501.01	2547	2592.99	2638.98	2685	
10M	DFT-S PI/2 BPSK	1	1	23.10	23.30	23.64	23.03	23.32	0
10M	DFT-S QPSK	1	1	23.18	23.41	23.81	23.27	23.39	0
		1	11	22.90	23.22	23.53	22.93	23.13	0
		1	22	22.20	22.38	22.72	22.21	22.35	0
		12	0	22.20	22.33	22.69	22.13	22.40	1
		12	6	23.12	23.34	23.62	23.07	23.36	0
		12	12	22.08	22.39	22.63	22.12	22.39	1
		24	0	22.10	22.35	22.67	22.09	22.38	1
10M	DFT-S 16QAM	1	1	22.04	22.28	22.57	22.08	22.32	1
10M	DFT-S 64QAM	1	1	19.99	20.18	20.48	19.95	20.23	2.5
10M	DFT-S 256QAM	1	1	17.91	18.09	18.44	17.84	18.09	4.5
10M	CP QPSK	1	1	21.99	22.30	22.53	21.99	22.25	1.5

NR Conducted Power (Full)									
NR Band 77_PC2_SA									
BW	MCS Index	RB Size	RB Offset	Low	Mid-1	Mid-2	Mid-3	High	3GPP MPR (dB)
		Channel		650000	653000	656000	659000	662000	
		Frequency (MHz)		3750	3795	3840	3885	3930	
100M	DFT-S PI/2 BPSK	1	1	25.53	26.62	26.09	25.94	25.58	0
100M	DFT-S QPSK	1	1	25.62	26.71	26.18	26.03	25.67	0
		1	137	25.14	26.23	25.70	25.55	25.19	0
		1	271	25.11	26.20	25.67	25.52	25.16	0
		135	0	24.58	25.67	25.14	24.99	24.63	1
		135	69	25.61	26.70	26.17	26.02	25.66	0
		135	138	24.56	25.65	25.12	24.97	24.61	1
100M	DFT-S 16QAM	1	1	24.52	25.61	25.08	24.93	24.57	1
100M	DFT-S 64QAM	1	1	23.22	24.31	23.78	23.63	23.27	2.5
100M	DFT-S 256QAM	1	1	21.22	22.31	21.78	21.63	21.27	4.5
100M	CP QPSK	1	1	24.32	25.41	24.88	24.73	24.37	1.5
BW	MCS Index	Channel		649668	652834	656000	659166	662332	3GPP MPR
		Frequency (MHz)		3745.02	3792.51	3840	3887.49	3934.98	
90M	DFT-S PI/2 BPSK	1	1	25.46	26.62	26.06	25.50	26.60	0
90M	DFT-S QPSK	1	1	25.59	26.70	26.11	25.53	26.61	0
		1	123	25.11	26.18	25.62	25.10	26.15	0
		1	243	25.02	26.14	25.62	25.10	26.19	0
		120	0	24.52	25.57	25.06	24.54	25.65	1
		120	63	25.60	26.61	26.13	25.61	26.61	0
		120	125	24.46	25.55	25.02	24.48	25.61	1
90M	DFT-S 16QAM	1	1	24.51	25.57	25.05	24.47	25.54	1
90M	DFT-S 64QAM	1	1	23.17	24.29	23.69	23.13	24.21	2.5
90M	DFT-S 256QAM	1	1	21.12	22.26	21.75	21.15	22.27	4.5
90M	CP QPSK	1	1	24.24	25.41	24.84	24.28	25.33	1.5



NR Conducted Power (Full)									
NR Band 77_PC2_SA									
BW	MCS Index	Channel		649334	652666	656000	659334	662666	3GPP MPR
		Frequency (MHz)		3740.01	3789.99	3840	3890.01	3939.99	
80M	DFT-S PI/2 BPSK	1	1	25.51	26.58	26.02	25.45	26.55	0
80M	DFT-S QPSK	1	1	25.54	26.69	26.10	25.60	26.63	0
		1	109	25.10	26.17	25.69	25.13	26.16	0
		1	215	25.02	26.10	25.61	25.07	26.16	0
		108	0	24.55	25.65	25.08	24.53	25.61	1
		108	55	25.57	26.64	26.12	25.52	26.67	0
		108	109	24.51	25.61	25.06	24.55	25.65	1
80M	DFT-S 16QAM	1	1	24.43	25.54	25.00	24.46	25.58	1
80M	DFT-S 64QAM	1	1	23.15	24.24	23.76	23.20	24.22	2.5
80M	DFT-S 256QAM	1	1	21.15	22.30	21.76	21.16	22.27	4.5
80M	CP QPSK	1	1	24.24	25.36	24.82	24.27	25.34	1.5
BW	MCS Index	Channel		649000	652500	656000	659500	663000	3GPP MPR
		Frequency (MHz)		3735	3787.5	3840	3892.5	3945	
70M	DFT-S PI/2 BPSK	1	1	25.50	26.57	26.03	25.50	26.60	0
70M	DFT-S QPSK	1	1	25.61	26.68	26.14	25.55	26.61	0
		1	95	25.12	26.19	25.70	25.09	26.16	0
		1	187	25.09	26.20	25.64	25.06	26.17	0
		90	0	24.56	25.66	25.05	24.58	25.61	1
		90	50	25.61	26.65	26.14	25.51	26.65	0
		90	99	24.54	25.57	25.05	24.51	25.62	1
70M	DFT-S 16QAM	1	1	24.52	25.51	25.03	24.46	25.53	1
70M	DFT-S 64QAM	1	1	23.18	24.26	23.77	23.12	24.21	2.5
70M	DFT-S 256QAM	1	1	21.21	22.27	21.68	21.18	22.30	4.5
70M	CP QPSK	1	1	24.29	25.32	24.81	24.26	25.34	1.5

NR Conducted Power (Full)									
NR Band 77_PC2_SA									
BW	MCS Index	Channel		648668	652334	656000	659666	663332	3GPP MPR
		Frequency (MHz)		3730.02	3785.01	3840	3894.99	3949.98	
60M	DFT-S PI/2 BPSK	1	1	25.46	26.58	26.02	25.43	26.62	0
60M	DFT-S QPSK	1	1	25.58	26.66	26.18	25.62	26.70	0
		1	81	25.04	26.17	25.70	25.12	26.20	0
		1	160	25.09	26.20	25.61	25.09	26.12	0
		81	0	24.53	25.58	25.10	24.57	25.57	1
		81	41	25.60	26.69	26.11	25.61	26.69	0
		81	81	24.56	25.55	25.07	24.52	25.57	1
60M	DFT-S 16QAM	1	1	24.52	25.54	25.08	24.50	25.52	1
60M	DFT-S 64QAM	1	1	23.15	24.30	23.75	23.17	24.22	2.5
60M	DFT-S 256QAM	1	1	21.22	22.24	21.70	21.19	22.30	4.5
60M	CP QPSK	1	1	24.30	25.39	24.84	24.27	25.39	1.5
BW	MCS Index	Channel		648334	652166	656000	659834	663666	3GPP MPR
		Frequency (MHz)		3725.01	3782.49	3840	3897.51	3954.99	
50M	DFT-S PI/2 BPSK	1	1	25.53	26.60	26.05	25.48	26.54	0
50M	DFT-S QPSK	1	1	25.58	26.61	26.14	25.59	26.70	0
		1	67	25.10	26.23	25.70	25.06	26.21	0
		1	131	25.08	26.13	25.60	25.05	26.12	0
		64	0	24.54	25.65	25.07	24.55	25.62	1
		64	35	25.53	26.62	26.07	25.57	26.65	0
		64	69	24.56	25.64	25.05	24.48	25.57	1
50M	DFT-S 16QAM	1	1	24.42	25.55	25.01	24.46	25.51	1
50M	DFT-S 64QAM	1	1	23.19	24.31	23.75	23.20	24.31	2.5
50M	DFT-S 256QAM	1	1	21.16	22.27	21.77	21.22	22.26	4.5
50M	CP QPSK	1	1	24.22	25.39	24.87	24.31	25.41	1.5

NR Conducted Power (Full)									
NR Band 77_PC2_SA									
BW	MCS Index	Channel		648000	652000	656000	660000	664000	3GPP MPR
		Frequency (MHz)		3720	3780	3840	3900	3960	
40M	DFT-S PI/2 BPSK	1	1	25.51	26.52	26.04	25.49	26.61	0
40M	DFT-S QPSK	1	1	25.58	26.70	26.16	25.56	26.70	0
		1	53	25.08	26.19	25.63	25.07	26.18	0
		1	104	25.06	26.15	25.65	25.03	26.20	0
		50	0	24.56	25.67	25.11	24.51	25.59	1
		50	28	25.51	26.62	26.16	25.58	26.66	0
		50	56	24.54	25.60	25.02	24.47	25.64	1
100	0	24.50	25.57	25.04	24.57	25.61	1		
40M	DFT-S 16QAM	1	1	24.52	25.61	25.02	24.51	25.59	1
40M	DFT-S 64QAM	1	1	23.12	24.23	23.73	23.17	24.30	2.5
40M	DFT-S 256QAM	1	1	21.20	22.27	21.77	21.18	22.21	4.5
40M	CP QPSK	1	1	24.24	25.39	24.88	24.32	25.37	1.5
BW	MCS Index	Channel		647668	651834	656000	660166	664332	3GPP MPR
		Frequency (MHz)		3715.02	3777.51	3840	3902.49	3964.98	
30M	DFT-S PI/2 BPSK	1	1	25.53	26.58	26.05	25.51	26.56	0
30M	DFT-S QPSK	1	1	25.53	26.67	26.11	25.55	26.65	0
		1	39	25.10	26.21	25.68	25.12	26.17	0
		1	76	25.08	26.18	25.61	25.08	26.14	0
		36	0	24.56	25.61	25.13	24.49	25.62	1
		36	21	25.54	26.68	26.14	25.56	26.60	0
		36	42	24.54	25.61	25.05	24.53	25.60	1
75	0	24.51	25.57	25.09	24.54	25.66	1		
30M	DFT-S 16QAM	1	1	24.49	25.61	25.05	24.52	25.54	1
30M	DFT-S 64QAM	1	1	23.20	24.27	23.71	23.18	24.28	2.5
30M	DFT-S 256QAM	1	1	21.19	22.23	21.77	21.14	22.21	4.5
30M	CP QPSK	1	1	24.23	25.33	24.85	24.27	25.31	1.5

NR Conducted Power (Full)									
NR Band 77_PC2_SA									
BW	MCS Index	Channel		647500	651750	656000	660250	664500	3GPP MPR
		Frequency (MHz)		3712.5	3776.25	3840	3903.75	3967.5	
25M	DFT-S PI/2 BPSK								
25M	DFT-S QPSK								
25M	DFT-S 16QAM								
25M	DFT-S 64QAM								
25M	DFT-S 256QAM								
25M	CP QPSK								
25M									
BW	MCS Index	Channel		647334	651666	656000	660266	664666	3GPP MPR
		Frequency (MHz)		3710.01	3774.99	3840	3903.99	3969.99	
20M	DFT-S PI/2 BPSK	1	1	25.51	26.59	26.01	25.48	26.52	0
20M	DFT-S QPSK	1	1	25.54	26.62	26.13	25.62	26.68	0
		1	26	25.11	26.20	25.69	25.12	26.20	0
		1	49	25.02	26.16	25.59	25.10	26.13	0
		25	0	24.49	25.62	25.08	24.57	25.57	1
		25	13	25.59	26.68	26.09	25.61	26.66	0
		25	26	24.48	25.55	25.12	24.55	25.63	1
20M	DFT-S 16QAM	50	0	24.52	25.65	25.09	24.55	25.61	1
20M	DFT-S 16QAM	1	1	24.49	25.52	24.98	24.50	25.54	1
20M	DFT-S 64QAM	1	1	23.14	24.23	23.75	23.17	24.29	2.5
20M	DFT-S 256QAM	1	1	21.17	22.24	21.78	21.16	22.28	4.5
20M	CP QPSK	1	1	24.22	25.35	24.82	24.25	25.32	1.5

NR Conducted Power (Full)									
NR Band 77_PC2_SA									
BW	MCS Index	Channel		647168	651584	656000	660416	664832	3GPP MPR
		Frequency (MHz)		3707.52	3773.76	3840	3906.24	3972.48	
15M	DFT-S PI/2 BPSK	1	1	25.45	26.54	26.03	25.51	26.52	0
15M	DFT-S QPSK	1	1	25.54	26.67	26.17	25.55	26.66	0
		1	19	25.09	26.15	25.60	25.14	26.15	0
		1	36	25.05	26.13	25.58	25.04	26.16	0
		18	0	24.53	25.64	25.11	24.52	25.58	1
		18	10	25.53	26.66	26.16	25.61	26.68	0
		18	20	24.53	25.55	25.02	24.46	25.65	1
36	0	24.49	25.56	25.13	24.55	25.56	1		
15M	DFT-S 16QAM	1	1	24.45	25.60	25.05	24.48	25.58	1
15M	DFT-S 64QAM	1	1	23.21	24.30	23.75	23.18	24.29	2.5
15M	DFT-S 256QAM	1	1	21.17	22.23	21.72	21.13	22.27	4.5
15M	CP QPSK	1	1	24.26	25.34	24.86	24.31	25.38	1.5
BW	MCS Index	Channel		647000	651500	656000	660500	665000	3GPP MPR
		Frequency (MHz)		3705	3772.5	3840	3907.5	3975	
10M	DFT-S PI/2 BPSK	1	1	25.51	26.55	26.09	25.46	26.61	0
10M	DFT-S QPSK	1	1	25.56	26.69	26.16	25.57	26.62	0
		1	11	25.07	26.16	25.64	25.06	26.20	0
		1	22	25.11	26.14	25.60	25.04	26.19	0
		12	0	24.52	25.59	25.09	24.50	25.64	1
		12	6	25.51	26.69	26.13	25.53	26.69	0
		12	12	24.50	25.62	25.05	24.53	25.63	1
24	0	24.55	25.56	25.11	24.52	25.65	1		
10M	DFT-S 16QAM	1	1	24.49	25.57	25.03	24.45	25.57	1
10M	DFT-S 64QAM	1	1	23.13	24.29	23.74	23.14	24.21	2.5
10M	DFT-S 256QAM	1	1	21.14	22.25	21.73	21.21	22.22	4.5
10M	CP QPSK	1	1	24.22	25.37	24.87	24.30	25.33	1.5

NR Conducted Power (Full)									
NR Band 77_PC3_SA									
BW	MCS Index	RB Size	RB Offset	Low	Mid-1	Mid-2	Mid-3	High	3GPP MPR (dB)
		Channel		650000	653000	656000	659000	662000	
		Frequency (MHz)		3750	3795	3840	3885	3930	
100M	DFT-S PI/2 BPSK	1	1	23.89	23.84	23.63	23.33	23.10	0
100M	DFT-S QPSK	1	1	24.00	23.95	23.74	23.44	23.21	0
		1	137	23.54	23.49	23.29	23.00	22.78	0
		1	271	22.66	22.61	22.41	22.12	21.90	0
		135	0	22.60	22.55	22.35	22.06	21.84	1
		135	69	23.67	23.60	23.40	23.11	22.89	0
		135	138	22.47	22.42	22.22	21.93	21.71	1
270	0	22.44	22.39	22.19	21.90	21.68	1		
100M	DFT-S 16QAM	1	1	21.40	21.35	21.15	20.86	20.64	1
100M	DFT-S 64QAM	1	1	20.40	20.35	20.15	19.86	19.64	2.5
100M	DFT-S 256QAM	1	1	18.20	18.15	17.95	17.66	17.44	4.5
100M	CP QPSK	1	1	22.51	22.46	22.26	21.97	21.75	1.5
BW	MCS Index	Channel		649668	652834	656000	659166	662332	3GPP MPR
		Frequency (MHz)		3745.02	3792.51	3840	3887.49	3934.98	
90M	DFT-S PI/2 BPSK	1	1	23.83	23.81	23.56	23.75	23.62	0
90M	DFT-S QPSK	1	1	23.92	23.93	23.69	23.85	23.65	0
		1	123	23.53	23.45	23.26	23.45	23.23	0
		1	243	22.65	22.59	22.40	22.61	22.34	0
		120	0	22.58	22.49	22.27	22.45	22.34	1
		120	63	23.55	23.55	23.32	23.54	23.37	0
		120	125	22.45	22.42	22.19	22.35	22.17	1
243	0	22.41	22.36	22.17	22.29	22.17	1		
90M	DFT-S 16QAM	1	1	21.38	21.33	21.12	21.26	21.12	1
90M	DFT-S 64QAM	1	1	20.35	20.30	20.13	20.30	20.07	2.5
90M	DFT-S 256QAM	1	1	18.14	18.06	17.94	18.12	17.88	4.5
90M	CP QPSK	1	1	22.43	22.38	22.24	22.43	22.18	1.5

NR Conducted Power (Full)									
NR Band 77_PC3_SA									
BW	MCS Index	Channel		649334	652666	656000	659334	662666	3GPP MPR
		Frequency (MHz)		3740.01	3789.99	3840	3890.01	3939.99	
80M	DFT-S PI/2 BPSK	1	1	23.86	23.75	23.61	23.84	23.63	0
80M	DFT-S QPSK	1	1	23.99	23.92	23.69	23.94	23.68	0
		1	109	23.52	23.42	23.26	23.39	23.21	0
		1	215	22.56	22.56	22.35	22.51	22.35	0
		108	0	22.51	22.52	22.27	22.53	22.31	1
		108	55	23.59	23.55	23.36	23.58	23.30	0
		108	109	22.46	22.42	22.17	22.40	22.14	1
80M	DFT-S 16QAM	1	1	21.30	21.31	21.07	21.32	21.12	1
80M	DFT-S 64QAM	1	1	20.34	20.27	20.12	20.34	20.10	2.5
80M	DFT-S 256QAM	1	1	18.16	18.11	17.86	18.07	17.95	4.5
80M	CP QPSK	1	1	22.46	22.37	22.18	22.44	22.26	1.5
BW	MCS Index	Channel		649000	652500	656000	659500	663000	3GPP MPR
		Frequency (MHz)		3735	3787.5	3840	3892.5	3945	
70M	DFT-S PI/2 BPSK	1	1	23.85	23.76	23.63	23.76	23.58	0
70M	DFT-S QPSK	1	1	23.92	23.86	23.64	23.89	23.66	0
		1	95	23.49	23.41	23.24	23.40	23.27	0
		1	187	22.66	22.61	22.31	22.56	22.32	0
		90	0	22.57	22.52	22.31	22.50	22.29	1
		90	50	23.55	23.54	23.39	23.60	23.34	0
		90	99	22.46	22.34	22.20	22.36	22.12	1
70M	DFT-S 16QAM	1	1	21.30	21.30	21.10	21.30	21.06	1
70M	DFT-S 64QAM	1	1	20.39	20.26	20.12	20.29	20.12	2.5
70M	DFT-S 256QAM	1	1	18.18	18.09	17.85	18.08	17.86	4.5
70M	CP QPSK	1	1	22.45	22.37	22.24	22.46	22.21	1.5

NR Conducted Power (Full)									
NR Band 77_PC3_SA									
BW	MCS Index	Channel		648668	652334	656000	659666	663332	3GPP MPR
		Frequency (MHz)		3730.02	3785.01	3840	3894.99	3949.98	
60M	DFT-S PI/2 BPSK	1	1	23.83	23.81	23.63	23.74	23.61	0
60M	DFT-S QPSK	1	1	23.99	23.92	23.66	23.94	23.65	0
		1	81	23.53	23.43	23.27	23.40	23.21	0
		1	160	22.58	22.54	22.34	22.59	22.31	0
		81	0	22.54	22.51	22.33	22.52	22.30	1
		81	41	23.64	23.55	23.33	23.60	23.39	0
		81	81	22.44	22.37	22.14	22.36	22.16	1
60M	DFT-S 16QAM	1	1	21.32	21.35	21.07	21.32	21.12	1
60M	DFT-S 64QAM	1	1	20.36	20.33	20.06	20.29	20.15	2.5
60M	DFT-S 256QAM	1	1	18.14	18.14	17.90	18.10	17.90	4.5
60M	CP QPSK	1	1	22.51	22.44	22.24	22.45	22.20	1.5
BW	MCS Index	Channel		648334	652166	656000	659834	663666	3GPP MPR
		Frequency (MHz)		3725.01	3782.49	3840	3897.51	3954.99	
50M	DFT-S PI/2 BPSK	1	1	23.85	23.74	23.61	23.83	23.59	0
50M	DFT-S QPSK	1	1	23.90	23.94	23.67	23.90	23.67	0
		1	67	23.53	23.44	23.19	23.39	23.21	0
		1	131	22.58	22.54	22.40	22.60	22.39	0
		64	0	22.58	22.54	22.28	22.55	22.26	1
		64	35	23.65	23.57	23.32	23.56	23.39	0
		64	69	22.37	22.37	22.19	22.36	22.20	1
50M	DFT-S 16QAM	1	1	21.36	21.31	21.13	21.34	21.13	1
50M	DFT-S 64QAM	1	1	20.36	20.29	20.14	20.35	20.08	2.5
50M	DFT-S 256QAM	1	1	18.15	18.05	17.91	18.10	17.89	4.5
50M	CP QPSK	1	1	22.43	22.36	22.21	22.40	22.26	1.5



NR Conducted Power (Full)									
NR Band 77_PC3_SA									
BW	MCS Index	Channel		648000	652000	656000	660000	664000	3GPP MPR
		Frequency (MHz)		3720	3780	3840	3900	3960	
40M	DFT-S PI/2 BPSK	1	1	23.89	23.81	23.60	23.74	23.62	0
40M	DFT-S QPSK	1	1	23.94	23.85	23.64	23.95	23.73	0
		1	53	23.51	23.44	23.29	23.47	23.23	0
		1	104	22.66	22.61	22.36	22.60	22.36	0
		50	0	22.55	22.47	22.31	22.54	22.34	1
		50	28	23.55	23.56	23.39	23.52	23.37	0
		50	56	22.41	22.33	22.20	22.32	22.13	1
100	0	22.36	22.30	22.18	22.32	22.10	1		
40M	DFT-S 16QAM	1	1	21.32	21.30	21.10	21.28	21.15	1
40M	DFT-S 64QAM	1	1	20.30	20.31	20.11	20.31	20.08	2.5
40M	DFT-S 256QAM	1	1	18.14	18.08	17.88	18.12	17.90	4.5
40M	CP QPSK	1	1	22.48	22.43	22.22	22.38	22.17	1.5
BW	MCS Index	Channel		647668	651834	656000	660166	664332	3GPP MPR
		Frequency (MHz)		3715.02	3777.51	3840	3902.49	3964.98	
30M	DFT-S PI/2 BPSK	1	1	23.81	23.84	23.63	23.76	23.53	0
30M	DFT-S QPSK	1	1	23.91	23.94	23.65	23.94	23.66	0
		1	39	23.49	23.41	23.24	23.48	23.26	0
		1	76	22.64	22.51	22.36	22.59	22.41	0
		36	0	22.58	22.54	22.35	22.55	22.29	1
		36	21	23.64	23.51	23.34	23.55	23.38	0
		36	42	22.44	22.39	22.21	22.38	22.21	1
75	0	22.39	22.34	22.12	22.33	22.11	1		
30M	DFT-S 16QAM	1	1	21.38	21.26	21.14	21.33	21.14	1
30M	DFT-S 64QAM	1	1	20.34	20.31	20.12	20.32	20.13	2.5
30M	DFT-S 256QAM	1	1	18.13	18.14	17.89	18.13	17.87	4.5
30M	CP QPSK	1	1	22.50	22.42	22.16	22.45	22.17	1.5

NR Conducted Power (Full)									
NR Band 77_PC3_SA									
BW	MCS Index	Channel		647500	651750	656000	660250	664500	3GPP MPR
		Frequency (MHz)		3712.5	3776.25	3840	3903.75	3967.5	
25M	DFT-S PI/2 BPSK								
25M	DFT-S QPSK								
25M	DFT-S 16QAM								
25M	DFT-S 64QAM								
25M	DFT-S 256QAM								
25M	CP QPSK								
25M									
BW	MCS Index	Channel		647334	651666	656000	660266	664666	3GPP MPR
		Frequency (MHz)		3710.01	3774.99	3840	3903.99	3969.99	
20M	DFT-S PI/2 BPSK	1	1	23.83	23.78	23.62	23.79	23.60	0
20M	DFT-S QPSK	1	1	23.99	23.95	23.66	23.91	23.66	0
		1	26	23.54	23.48	23.29	23.41	23.25	0
		1	49	22.61	22.60	22.37	22.61	22.36	0
		25	0	22.53	22.54	22.28	22.54	22.35	1
		25	13	23.59	23.50	23.30	23.56	23.38	0
		25	26	22.47	22.36	22.15	22.40	22.21	1
20M	DFT-S 16QAM	50	0	22.41	22.34	22.15	22.30	22.15	1
20M	DFT-S 16QAM	1	1	21.37	21.33	21.11	21.27	21.15	1
20M	DFT-S 64QAM	1	1	20.35	20.25	20.14	20.27	20.11	2.5
20M	DFT-S 256QAM	1	1	18.16	18.07	17.88	18.11	17.87	4.5
20M	CP QPSK	1	1	22.51	22.39	22.21	22.42	22.19	1.5

NR Conducted Power (Full)									
NR Band 77_PC3_SA									
BW	MCS Index	Channel		647168	651584	656000	660416	664832	3GPP MPR
		Frequency (MHz)		3707.52	3773.76	3840	3906.24	3972.48	
15M	DFT-S PI/2 BPSK	1	1	23.82	23.78	23.53	23.75	23.61	0
15M	DFT-S QPSK	1	1	23.95	23.95	23.64	23.88	23.69	0
		1	19	23.47	23.40	23.20	23.49	23.21	0
		1	36	22.58	22.59	22.40	22.53	22.35	0
		18	0	22.56	22.53	22.26	22.51	22.32	1
		18	10	23.60	23.58	23.33	23.51	23.36	0
		18	20	22.45	22.38	22.13	22.33	22.17	1
36	0	22.38	22.32	22.15	22.37	22.19	1		
15M	DFT-S 16QAM	1	1	21.30	21.25	21.15	21.27	21.09	1
15M	DFT-S 64QAM	1	1	20.30	20.34	20.05	20.33	20.13	2.5
15M	DFT-S 256QAM	1	1	18.11	18.13	17.85	18.10	17.86	4.5
15M	CP QPSK	1	1	22.50	22.45	22.18	22.43	22.25	1.5
BW	MCS Index	Channel		647000	651500	656000	660500	665000	3GPP MPR
		Frequency (MHz)		3705	3772.5	3840	3907.5	3975	
10M	DFT-S PI/2 BPSK	1	1	23.83	23.84	23.56	23.83	23.62	0
10M	DFT-S QPSK	1	1	23.91	23.88	23.69	23.87	23.69	0
		1	11	23.44	23.39	23.29	23.47	23.21	0
		1	22	22.65	22.58	22.40	22.53	22.35	0
		12	0	22.57	22.47	22.27	22.47	22.35	1
		12	6	23.62	23.52	23.32	23.59	23.39	0
		12	12	22.43	22.33	22.17	22.40	22.21	1
24	0	22.35	22.36	22.11	22.36	22.16	1		
10M	DFT-S 16QAM	1	1	21.32	21.27	21.08	21.35	21.12	1
10M	DFT-S 64QAM	1	1	20.30	20.29	20.15	20.30	20.06	2.5
10M	DFT-S 256QAM	1	1	18.10	18.11	17.93	18.06	17.90	4.5
10M	CP QPSK	1	1	22.42	22.46	22.17	22.44	22.26	1.5

NR Conducted Power (Full)							
NR Band 78_PC2_SA							
BW	MCS Index	RB Size	RB Offset	Low	Mid	High	3GPP MPR (dB)
		Channel			650000		
		Frequency (MHz)			3750		
100M	DFT-S PI/2 BPSK	1	1		25.62		0
100M	DFT-S QPSK	1	1		25.71		0
		1	137		25.35		0
		1	271		24.47		0
		135	0		24.41		1
		135	69		25.46		0
		135	138		24.28		1
270	0		24.25		1		
100M	DFT-S 16QAM	1	1		24.61		1
100M	DFT-S 64QAM	1	1		23.31		2.5
100M	DFT-S 256QAM	1	1		21.31		4.5
100M	CP QPSK	1	1		24.41		1.5
BW	MCS Index	Channel		649668	650000	650332	3GPP MPR
		Frequency (MHz)		3745.02	3750	3754.98	
90M	DFT-S PI/2 BPSK	1	1	25.58	25.59	25.61	0
90M	DFT-S QPSK	1	1	25.64	25.70	25.63	0
		1	123	25.31	25.33	25.34	0
		1	243	24.40	24.38	24.44	0
		120	0	24.38	24.37	24.38	1
		120	63	25.39	25.37	25.42	0
		120	125	24.24	24.21	24.22	1
243	0	24.18	24.16	24.15	1		
90M	DFT-S 16QAM	1	1	24.58	24.54	24.56	1
90M	DFT-S 64QAM	1	1	23.21	23.29	23.31	2.5
90M	DFT-S 256QAM	1	1	21.27	21.21	21.28	4.5
90M	CP QPSK	1	1	24.35	24.37	24.32	1.5

NR Conducted Power (Full)							
NR Band 78_PC2_SA							
BW	MCS Index	Channel		649334	650000	650666	3GPP MPR
		Frequency (MHz)		3740.01	3750	3759.99	
80M	DFT-S PI/2 BPSK	1	1	25.59	25.60	25.58	0
80M	DFT-S QPSK	1	1	25.62	25.65	25.69	0
		1	109	25.26	25.31	25.32	0
		1	215	24.41	24.42	24.37	0
		108	0	24.35	24.33	24.41	1
		108	55	25.39	25.36	25.44	0
		108	109	24.21	24.24	24.25	1
80M	DFT-S 16QAM	1	1	24.54	24.58	24.57	1
80M	DFT-S 64QAM	1	1	23.23	23.29	23.28	2.5
80M	DFT-S 256QAM	1	1	21.28	21.31	21.25	4.5
80M	CP QPSK	1	1	24.33	24.31	24.37	1.5
BW	MCS Index	Channel		649000		651000	3GPP MPR
		Frequency (MHz)		3735		3765	
70M	DFT-S PI/2 BPSK	1	1	25.52	25.54	25.55	0
70M	DFT-S QPSK	1	1	25.65	25.61	25.70	0
		1	95	25.27	25.27	25.29	0
		1	187	24.42	24.41	24.42	0
		90	0	24.38	24.35	24.36	1
		90	50	25.39	25.43	25.45	0
		90	99	24.22	24.28	24.22	1
70M	DFT-S 16QAM	1	1	24.51	24.52	24.59	1
70M	DFT-S 64QAM	1	1	23.26	23.24	23.29	2.5
70M	DFT-S 256QAM	1	1	21.28	21.30	21.31	4.5
70M	CP QPSK	1	1	24.41	24.37	24.39	1.5

NR Conducted Power (Full)							
NR Band 78_PC2_SA							
BW	MCS Index	Channel		648668	650000	651332	3GPP MPR
		Frequency (MHz)		3730.02	3750	3769.98	
60M	DFT-S PI/2 BPSK	1	1	25.58	25.59	25.58	0
60M	DFT-S QPSK	1	1	25.68	25.70	25.67	0
		1	81	25.25	25.33	25.27	0
		1	160	24.45	24.46	24.37	0
		81	0	24.34	24.32	24.41	1
		81	41	25.38	25.39	25.46	0
		81	81	24.20	24.23	24.28	1
60M	DFT-S 16QAM	1	1	24.61	24.54	24.52	1
60M	DFT-S 64QAM	1	1	23.30	23.23	23.30	2.5
60M	DFT-S 256QAM	1	1	21.25	21.25	21.31	4.5
60M	CP QPSK	1	1	24.35	24.38	24.40	1.5
BW	MCS Index	Channel		648334	650000	651666	3GPP MPR
		Frequency (MHz)		3725.01	3750	3774.99	
50M	DFT-S PI/2 BPSK	1	1	25.61	25.53	25.59	0
50M	DFT-S QPSK	1	1	25.62	25.66	25.63	0
		1	67	25.32	25.28	25.26	0
		1	131	24.42	24.44	24.40	0
		64	0	24.39	24.36	24.31	1
		64	35	25.36	25.42	25.45	0
		64	69	24.19	24.25	24.22	1
50M	DFT-S 16QAM	1	1	24.52	24.53	24.53	1
50M	DFT-S 64QAM	1	1	23.21	23.28	23.24	2.5
50M	DFT-S 256QAM	1	1	21.29	21.25	21.21	4.5
50M	CP QPSK	1	1	24.36	24.36	24.41	1.5

NR Conducted Power (Full)							
NR Band 78_PC2_SA							
BW	MCS Index	Channel		648000	650000	652000	3GPP MPR
		Frequency (MHz)		3720	3750	3780	
40M	DFT-S PI/2 BPSK	1	1	25.54	25.54	25.60	0
40M	DFT-S QPSK	1	1	25.62	25.62	25.66	0
		1	53	25.28	25.33	25.26	0
		1	104	24.43	24.42	24.38	0
		50	0	24.38	24.39	24.35	1
		50	28	25.41	25.37	25.40	0
		50	56	24.26	24.18	24.26	1
100	0	24.18	24.23	24.19	1		
40M	DFT-S 16QAM	1	1	24.54	24.51	24.56	1
40M	DFT-S 64QAM	1	1	23.21	23.26	23.24	2.5
40M	DFT-S 256QAM	1	1	21.24	21.25	21.29	4.5
40M	CP QPSK	1	1	24.36	24.33	24.36	1.5
BW	MCS Index	Channel		647668	650000	652332	3GPP MPR
		Frequency (MHz)		3715.02	3750	3784.98	
30M	DFT-S PI/2 BPSK	1	1	25.61	25.61	25.59	0
30M	DFT-S QPSK	1	1	25.63	25.69	25.65	0
		1	39	25.32	25.34	25.26	0
		1	76	24.41	24.38	24.41	0
		36	0	24.37	24.39	24.37	1
		36	21	25.46	25.43	25.45	0
		36	42	24.21	24.20	24.18	1
75	0	24.15	24.22	24.19	1		
30M	DFT-S 16QAM	1	1	24.58	24.61	24.57	1
30M	DFT-S 64QAM	1	1	23.28	23.30	23.22	2.5
30M	DFT-S 256QAM	1	1	21.24	21.22	21.21	4.5
30M	CP QPSK	1	1	24.31	24.36	24.35	1.5

NR Conducted Power (Full)								
NR Band 78_PC2_SA								
BW	MCS Index	Channel		647500	650000	652500	3GPP MPR	
		Frequency (MHz)		3712.5	3750	3787.5		
25M	DFT-S PI/2 BPSK							
25M	DFT-S QPSK							
25M	DFT-S 16QAM							
25M	DFT-S 64QAM							
25M	DFT-S 256QAM							
25M	CP QPSK							
25M								
BW	MCS Index	Channel		647334	650000	652666	3GPP MPR	
		Frequency (MHz)		3710.01	3750	3789.99		
20M	DFT-S PI/2 BPSK	1	1	25.55	25.54	25.61	0	
20M	DFT-S QPSK	1	1	25.62	25.70	25.70	0	
		1	26	25.33	25.34	25.31	0	
		1	49	24.46	24.41	24.44	0	
		25	0	24.34	24.35	24.34	1	
		25	13	25.41	25.40	25.40	0	
		25	26	24.18	24.27	24.25	1	
20M	DFT-S 16QAM	1	1	24.53	24.51	24.52	1	
20M	DFT-S 64QAM	1	1	23.25	23.24	23.27	2.5	
20M	DFT-S 256QAM	1	1	21.23	21.25	21.30	4.5	
20M	CP QPSK	1	1	24.34	24.39	24.39	1.5	



NR Conducted Power (Full)							
NR Band 78_PC2_SA							
BW	MCS Index	Channel		647168	650000	652832	3GPP MPR
		Frequency (MHz)		3707.52	3750	3792.48	
15M	DFT-S PI/2 BPSK	1	1	25.52	25.58	25.58	0
15M	DFT-S QPSK	1	1	25.63	25.64	25.70	0
		1	19	25.33	25.29	25.33	0
		1	36	24.38	24.37	24.44	0
		18	0	24.31	24.35	24.40	1
		18	10	25.39	25.45	25.38	0
		18	20	24.18	24.26	24.27	1
36	0	24.21	24.19	24.17	1		
15M	DFT-S 16QAM	1	1	24.52	24.52	24.55	1
15M	DFT-S 64QAM	1	1	23.31	23.28	23.31	2.5
15M	DFT-S 256QAM	1	1	21.30	21.31	21.22	4.5
15M	CP QPSK	1	1	24.35	24.37	24.35	1.5
BW	MCS Index	Channel		647000	650000	653000	3GPP MPR
		Frequency (MHz)		3705	3750	3795	
10M	DFT-S PI/2 BPSK	1	1	25.61	25.55	25.61	0
10M	DFT-S QPSK	1	1	25.66	25.70	25.66	0
		1	11	25.28	25.34	25.28	0
		1	22	24.40	24.44	24.44	0
		12	0	24.34	24.39	24.39	1
		12	6	25.39	25.36	25.46	0
		12	12	24.28	24.25	24.26	1
24	0	24.22	24.17	24.15	1		
10M	DFT-S 16QAM	1	1	24.54	24.53	24.51	1
10M	DFT-S 64QAM	1	1	23.26	23.28	23.22	2.5
10M	DFT-S 256QAM	1	1	21.28	21.28	21.28	4.5
10M	CP QPSK	1	1	24.37	24.34	24.32	1.5

NR Conducted Power (Full)							
NR Band 78_PC3_SA							
BW	MCS Index	RB Size	RB Offset	Low	Mid	High	3GPP MPR (dB)
		Channel			650000		
		Frequency (MHz)			3750		
100M	DFT-S PI/2 BPSK	1	1		23.65		0
100M	DFT-S QPSK	1	1		23.78		0
		1	137		23.34		0
		1	271		22.46		0
		135	0		22.40		1
		135	69		23.47		0
		135	138		22.27		1
100M	DFT-S 16QAM	1	1		22.32		1
100M	DFT-S 64QAM	1	1		20.20		2.5
100M	DFT-S 256QAM	1	1		18.10		4.5
100M	CP QPSK	1	1		21.30		1.5
BW	MCS Index	Channel		649668	650000	650332	3GPP MPR
		Frequency (MHz)		3745.02	3750	3754.98	
90M	DFT-S PI/2 BPSK	1	1	23.58	23.56	23.55	0
90M	DFT-S QPSK	1	1	23.67	23.76	23.69	0
		1	123	23.29	23.31	23.31	0
		1	243	22.40	22.41	22.36	0
		120	0	22.39	22.40	22.40	1
		120	63	23.37	23.40	23.38	0
		120	125	22.18	22.26	22.21	1
90M	DFT-S 16QAM	1	1	22.22	22.30	22.27	1
90M	DFT-S 64QAM	1	1	20.10	20.19	20.20	2.5
90M	DFT-S 256QAM	1	1	18.03	18.08	18.09	4.5
90M	CP QPSK	1	1	21.29	21.25	21.27	1.5

NR Conducted Power (Full)							
NR Band 78_PC3_SA							
BW	MCS Index	Channel		649334	650000	650666	3GPP MPR
		Frequency (MHz)		3740.01	3750	3759.99	
80M	DFT-S PI/2 BPSK	1	1	23.60	23.60	23.56	0
80M	DFT-S QPSK	1	1	23.72	23.69	23.76	0
		1	109	23.34	23.25	23.27	0
		1	215	22.42	22.41	22.44	0
		108	0	22.33	22.33	22.34	1
		108	55	23.39	23.35	23.42	0
		108	109	22.21	22.17	22.20	1
80M	DFT-S 16QAM	1	1	22.31	22.31	22.30	1
80M	DFT-S 64QAM	1	1	20.15	20.15	20.11	2.5
80M	DFT-S 256QAM	1	1	18.09	18.05	18.08	4.5
80M	CP QPSK	1	1	21.29	21.25	21.22	1.5
BW	MCS Index	Channel		649000	650000	651000	3GPP MPR
		Frequency (MHz)		3735	3750	3765	
70M	DFT-S PI/2 BPSK	1	1	23.61	23.63	23.58	0
70M	DFT-S QPSK	1	1	23.66	23.72	23.72	0
		1	95	23.31	23.32	23.28	0
		1	187	22.38	22.39	22.39	0
		90	0	22.35	22.31	22.34	1
		90	50	23.43	23.44	23.35	0
		90	99	22.18	22.19	22.25	1
70M	DFT-S 16QAM	1	1	22.23	22.32	22.29	1
70M	DFT-S 64QAM	1	1	20.13	20.20	20.17	2.5
70M	DFT-S 256QAM	1	1	18.01	18.03	18.03	4.5
70M	CP QPSK	1	1	21.29	21.29	21.25	1.5

NR Conducted Power (Full)							
NR Band 78_PC3_SA							
BW	MCS Index	Channel		648668	650000	651332	3GPP MPR
		Frequency (MHz)		3730.02	3750	3769.98	
60M	DFT-S PI/2 BPSK	1	1	23.61	23.64	23.61	0
60M	DFT-S QPSK	1	1	23.72	23.69	23.74	0
		1	81	23.26	23.33	23.24	0
		1	160	22.38	22.44	22.36	0
		81	0	22.31	22.34	22.40	1
		81	41	23.40	23.35	23.42	0
		81	81	22.27	22.19	22.20	1
60M	DFT-S 16QAM	1	1	22.29	22.22	22.25	1
60M	DFT-S 64QAM	1	1	20.20	20.19	20.14	2.5
60M	DFT-S 256QAM	1	1	18.00	18.08	18.05	4.5
60M	CP QPSK	1	1	21.23	21.20	21.22	1.5
BW	MCS Index	Channel		648334	650000	651666	3GPP MPR
		Frequency (MHz)		3725.01	3750	3774.99	
50M	DFT-S PI/2 BPSK	1	1	23.57	23.63	23.56	0
50M	DFT-S QPSK	1	1	23.69	23.73	23.72	0
		1	67	23.28	23.28	23.28	0
		1	131	22.40	22.37	22.37	0
		64	0	22.32	22.33	22.35	1
		64	35	23.37	23.36	23.41	0
		64	69	22.18	22.26	22.18	1
50M	DFT-S 16QAM	1	1	22.26	22.28	22.29	1
50M	DFT-S 64QAM	1	1	20.17	20.11	20.14	2.5
50M	DFT-S 256QAM	1	1	18.06	18.07	18.04	4.5
50M	CP QPSK	1	1	21.27	21.27	21.23	1.5

NR Conducted Power (Full)							
NR Band 78_PC3_SA							
BW	MCS Index	Channel		648000	650000	652000	3GPP MPR
		Frequency (MHz)		3720	3750	3780	
40M	DFT-S PI/2 BPSK	1	1	23.63	23.61	23.56	0
40M	DFT-S QPSK	1	1	23.69	23.75	23.70	0
		1	53	23.26	23.34	23.26	0
		1	104	22.42	22.40	22.44	0
		50	0	22.30	22.40	22.32	1
		50	28	23.37	23.39	23.38	0
		50	56	22.24	22.22	22.25	1
100	0	22.23	22.15	22.23	1		
40M	DFT-S 16QAM	1	1	22.31	22.27	22.25	1
40M	DFT-S 64QAM	1	1	20.18	20.20	20.20	2.5
40M	DFT-S 256QAM	1	1	18.04	18.05	18.06	4.5
40M	CP QPSK	1	1	21.23	21.26	21.21	1.5
BW	MCS Index	Channel		647668	650000	652332	3GPP MPR
		Frequency (MHz)		3715.02	3750	3784.98	
30M	DFT-S PI/2 BPSK	1	1	23.63	23.63	23.58	0
30M	DFT-S QPSK	1	1	23.72	23.71	23.69	0
		1	39	23.28	23.24	23.27	0
		1	76	22.37	22.37	22.44	0
		36	0	22.30	22.38	22.39	1
		36	21	23.39	23.36	23.37	0
		36	42	22.20	22.24	22.17	1
75	0	22.18	22.23	22.18	1		
30M	DFT-S 16QAM	1	1	22.26	22.23	22.31	1
30M	DFT-S 64QAM	1	1	20.15	20.11	20.16	2.5
30M	DFT-S 256QAM	1	1	18.06	18.02	18.00	4.5
30M	CP QPSK	1	1	21.20	21.24	21.25	1.5

NR Conducted Power (Full)								
NR Band 78_PC3_SA								
BW	MCS Index	Channel		647500	650000	652500	3GPP MPR	
		Frequency (MHz)		3712.5	3750	3787.5		
25M	DFT-S PI/2 BPSK							
25M	DFT-S QPSK							
25M	DFT-S 16QAM							
25M	DFT-S 64QAM							
25M	DFT-S 256QAM							
25M	CP QPSK							
25M								
BW	MCS Index	Channel		647334	650000	652666	3GPP MPR	
		Frequency (MHz)		3710.01	3750	3789.99		
20M	DFT-S PI/2 BPSK	1	1	23.61	23.58	23.62	0	
20M	DFT-S QPSK	1	1	23.72	23.66	23.73	0	
		1	26	23.34	23.26	23.24	0	
		1	49	22.41	22.39	22.40	0	
		25	0	22.39	22.32	22.39	1	
		25	13	23.36	23.42	23.35	0	
		25	26	22.24	22.17	22.24	1	
20M	DFT-S 16QAM	50	0	22.21	22.20	22.20	1	
20M	DFT-S 16QAM	1	1	22.31	22.22	22.24	1	
20M	DFT-S 64QAM	1	1	20.13	20.13	20.19	2.5	
20M	DFT-S 256QAM	1	1	18.09	18.05	18.00	4.5	
20M	CP QPSK	1	1	21.30	21.28	21.26	1.5	

NR Conducted Power (Full)							
NR Band 78_PC3_SA							
BW	MCS Index	Channel		647168	650000	652832	3GPP MPR
		Frequency (MHz)		3707.52	3750	3792.48	
15M	DFT-S PI/2 BPSK	1	1	23.64	23.62	23.58	0
15M	DFT-S QPSK	1	1	23.69	23.67	23.73	0
		1	19	23.24	23.30	23.27	0
		1	36	22.43	22.36	22.41	0
		18	0	22.35	22.37	22.33	1
		18	10	23.45	23.42	23.36	0
		18	20	22.20	22.17	22.20	1
36	0	22.17	22.16	22.16	1		
15M	DFT-S 16QAM	1	1	22.22	22.26	22.28	1
15M	DFT-S 64QAM	1	1	20.18	20.15	20.11	2.5
15M	DFT-S 256QAM	1	1	18.01	18.04	18.00	4.5
15M	CP QPSK	1	1	21.24	21.21	21.27	1.5
BW	MCS Index	Channel		647000	650000	653000	3GPP MPR
		Frequency (MHz)		3705	3750	3795	
10M	DFT-S PI/2 BPSK	1	1	23.64	23.64	23.55	0
10M	DFT-S QPSK	1	1	23.69	23.68	23.66	0
		1	11	23.29	23.33	23.34	0
		1	22	22.44	22.43	22.44	0
		12	0	22.39	22.32	22.31	1
		12	6	23.43	23.36	23.36	0
		12	12	22.19	22.20	22.19	1
24	0	22.22	22.20	22.18	1		
10M	DFT-S 16QAM	1	1	22.26	22.26	22.23	1
10M	DFT-S 64QAM	1	1	20.17	20.18	20.19	2.5
10M	DFT-S 256QAM	1	1	18.04	18.02	18.10	4.5
10M	CP QPSK	1	1	21.25	21.20	21.23	1.5

## NR Conducted Power (Full)

### NR Band 2\_NSA

BW	MCS Index	RB Size	RB Offset	Low	Mid	High	3GPP MPR (dB)
		Channel		372000	376000	380000	
		Frequency (MHz)		1860	1880	1900	
20M	DFT-S PI/2 BPSK	1	1	23.81	23.84	23.71	0
20M	DFT-S QPSK	1	1	23.83	23.86	23.74	0
		1	53	23.80	23.83	23.70	0
		1	104	23.79	23.80	23.75	0
		50	0	22.83	22.86	22.77	1
		50	28	23.79	23.84	23.69	0
		50	56	22.77	22.83	22.69	1
		100	0	22.80	22.85	22.74	1
20M	DFT-S 16QAM	1	1	22.75	22.83	22.68	1
20M	DFT-S 64QAM	1	1	21.05	21.06	21.03	2.5
20M	DFT-S 256QAM	1	1	19.27	19.31	19.27	4.5
20M	CP QPSK	1	1	22.36	22.36	22.35	1.5



## NR Conducted Power (Full)

### NR Band 5\_NSA

BW	MCS Index	RB Size	RB Offset	Low	Mid	High	3GPP MPR (dB)
		Channel		166800	167300	167800	
		Frequency (MHz)		834	836.5	839	
20M	DFT-S PI/2 BPSK	1	1	22.77	22.96	22.86	0
20M	DFT-S QPSK	1	1	22.79	22.99	22.91	0
		1	53	22.86	22.96	22.90	0
		1	104	22.76	22.93	22.86	0
		50	0	21.98	22.06	22.02	1
		50	28	22.83	22.97	22.92	0
		50	56	22.22	22.26	22.23	1
		100	0	22.13	22.21	22.17	1
20M	DFT-S 16QAM	1	1	22.03	22.09	22.04	1
20M	DFT-S 64QAM	1	1	19.93	20.10	20.03	2.5
20M	DFT-S 256QAM	1	1	18.36	18.51	18.43	4.5
20M	CP QPSK	1	1	21.41	21.56	21.48	1.5

## NR Conducted Power (Full)

### NR Band 7\_NSA

BW	MCS Index	RB Size	RB Offset	Low	Mid	High	3GPP MPR (dB)
		Channel		502000	507000	512000	
		Frequency (MHz)		2510	2535	2560	
20M	DFT-S PI/2 BPSK	1	1	22.01	22.14	22.03	0
20M	DFT-S QPSK	1	1	22.22	22.35	22.24	0
		1	53	22.09	22.22	22.11	0
		1	104	22.08	22.21	22.10	0
		50	0	21.10	21.23	21.12	1
		50	28	22.09	22.22	22.11	0
		50	56	21.06	21.19	21.08	1
		100	0	21.00	21.13	21.02	1
20M	DFT-S 16QAM	1	1	21.01	21.12	21.08	1
20M	DFT-S 64QAM	1	1	19.70	19.83	19.72	2.5
20M	DFT-S 256QAM	1	1	17.90	18.03	17.92	4.5
20M	CP QPSK	1	1	21.06	21.19	21.08	1.5

## NR Conducted Power (Full)

### NR Band 25\_NSA

BW	MCS Index	RB Size	RB Offset	Low	Mid	High	3GPP MPR (dB)
		Channel		372000	376500	381000	
		Frequency (MHz)		1860	1882.5	1905	
20M	DFT-S PI/2 BPSK	1	1	22.04	22.58	22.68	0
20M	DFT-S QPSK	1	1	22.25	22.79	22.89	0
		1	53	22.21	22.75	22.85	0
		1	104	21.96	22.50	22.60	0
		50	0	21.15	21.69	21.79	1
		50	28	22.11	22.65	22.75	0
		50	56	21.03	21.57	21.67	1
		100	0	20.95	21.49	21.59	1
20M	DFT-S 16QAM	1	1	21.04	21.58	21.68	1
20M	DFT-S 64QAM	1	1	19.75	20.29	20.39	2.5
20M	DFT-S 256QAM	1	1	17.95	18.49	18.59	4.5
20M	CP QPSK	1	1	21.11	21.65	21.75	1.5

## NR Conducted Power (Full)

### NR Band 30\_NSA

BW	MCS Index	RB Size	RB Offset		Mid		3GPP MPR (dB)
		Channel			462000		
		Frequency (MHz)			2310		
10M	DFT-S PI/2 BPSK	1	1		22.58		0
10M	DFT-S QPSK	1	1		22.71		0
		1	26		22.59		0
		1	50		22.44		0
		25	0		21.29		1
		25	14		22.1		0
		25	27		21.03		1
		50	0		20.93		1
10M	DFT-S 16QAM	1	1		21.18		1
10M	DFT-S 64QAM	1	1		19.89		2.5
10M	DFT-S 256QAM	1	1		18.09		4.5
10M	CP QPSK	1	1		21.25		1.5

## NR Conducted Power (Full)

### NR Band 66\_NSA

BW	MCS Index	RB Size	RB Offset	Low	Mid	High	3GPP MPR (dB)
		Channel		346000	349000	352000	
		Frequency (MHz)		1730	1745	1760	
40M	DFT-S PI/2 BPSK	1	1	23.39	23.68	23.60	0
40M	DFT-S QPSK	1	1	23.48	23.78	23.69	0
		1	108	23.45	23.67	23.58	0
		1	214	23.48	23.70	23.67	0
		108	0	22.07	22.28	22.20	1
		108	54	23.63	23.77	23.74	0
		108	108	22.42	22.50	22.47	1
		216	0	22.29	22.44	22.42	1
40M	DFT-S 16QAM	1	1	22.52	22.67	22.67	1
40M	DFT-S 64QAM	1	1	20.78	20.87	20.87	2.5
40M	DFT-S 256QAM	1	1	19.01	19.25	19.22	4.5
40M	CP QPSK	1	1	22.19	22.40	22.31	1.5

## NR Conducted Power (Full)

### NR Band 71\_NSA

BW	MCS Index	RB Size	RB Offset	Low	Mid	High	3GPP MPR (dB)
		Channel		134600	136100	137600	
		Frequency (MHz)		673	680.5	688	
20M	DFT-S PI/2 BPSK	1	1	23.21	23.41	23.18	0
20M	DFT-S QPSK	1	1	23.33	23.53	23.30	0
		1	53	23.13	23.33	23.10	0
		1	104	23.00	23.20	22.97	0
		50	0	22.51	22.71	22.48	1
		50	28	23.16	23.36	23.13	0
		50	56	22.46	22.60	22.40	1
		100	0	22.25	22.45	22.22	1
20M	DFT-S 16QAM	1	1	22.36	22.56	22.33	1
20M	DFT-S 64QAM	1	1	21.13	21.20	21.06	2.5
20M	DFT-S 256QAM	1	1	19.02	19.08	19.00	4.5
20M	CP QPSK	1	1	22.03	22.07	21.96	1.5

NR Conducted Power (Full)							
NR Band 38_NSA							
BW	MCS Index	RB Size	RB Offset	Low	Mid	High	3GPP MPR (dB)
		Channel		516000	519000	522000	
		Frequency (MHz)		2580	2595	2610	
20M	DFT-S PI/2 BPSK	1	1	23.12	23.14	23.10	0
20M	DFT-S QPSK	1	1	23.24	23.26	23.22	0
		1	26	23.21	23.23	23.18	0
		1	49	23.12	23.14	23.09	0
		25	0	22.29	22.31	22.26	1
		25	13	23.09	23.11	23.06	0
		25	26	22.22	22.24	22.19	1
		50	0	22.18	22.20	22.15	1
20M	DFT-S 16QAM	1	1	22.14	22.16	22.11	1
20M	DFT-S 64QAM	1	1	20.77	20.81	20.72	2.5
20M	DFT-S 256QAM	1	1	18.65	18.72	18.59	4.5
20M	CP QPSK	1	1	21.67	21.75	21.61	1.5

NR Conducted Power (Full)							
NR Band 40_NSA							
BW	MCS Index	RB Size	RB Offset	Low	Mid	High	3GPP MPR (dB)
		Channel		468000	470000	472000	
		Frequency (MHz)		2340	2350	2360	
80M	DFT-S PI/2 BPSK	1	1	23.32	23.42	23.41	0
80M	DFT-S QPSK	1	1	23.57	23.61	23.51	0
		1	109	23.33	23.43	23.35	0
		1	215	23.28	23.39	23.31	0
		108	0	22.71	22.75	22.73	1
		108	55	23.47	23.49	23.44	0
		108	109	22.40	22.50	22.44	1
		216	0	22.36	22.48	22.38	1
80M	DFT-S 16QAM	1	1	22.56	22.60	22.59	1
80M	DFT-S 64QAM	1	1	21.06	21.20	21.13	2.5
80M	DFT-S 256QAM	1	1	19.00	19.14	19.06	4.5
80M	CP QPSK	1	1	21.96	22.05	22.01	1.5



NR Conducted Power (Full)									
NR Band 41_PC2_NSA									
BW	MCS Index	RB Size	RB Offset	Low	Mid-1	Mid-2	Mid-3	High	3GPP MPR (dB)
		Channel		509202	513900	518598	523302	528000	
		Frequency (MHz)		2546.01	2569.5	2592.99	2616.51	2640	
100M	DFT-S PI/2 BPSK	1	1	26.49	26.51	26.54	26.47	26.50	0
100M	DFT-S QPSK	1	1	26.58	26.60	26.63	26.56	26.59	0
		1	137	26.39	26.41	26.54	26.37	26.40	0
		1	271	26.33	26.36	26.46	26.31	26.34	0
		135	0	25.60	25.62	25.65	25.58	25.61	1
		135	69	26.54	26.56	26.59	26.52	26.55	0
		135	138	25.56	25.58	25.61	25.54	25.57	1
		270	0	25.55	25.57	25.60	25.53	25.56	1
100M	DFT-S 16QAM	1	1	25.48	25.50	25.53	25.46	25.49	1
100M	DFT-S 64QAM	1	1	24.18	24.20	24.23	24.16	24.19	2.5
100M	DFT-S 256QAM	1	1	22.18	22.20	22.23	22.16	22.19	4.5
100M	CP QPSK	1	1	25.28	25.30	25.33	25.26	25.29	1.5

NR Conducted Power (Full)									
NR Band 41_PC3_NSA									
BW	MCS Index	RB Size	RB Offset	Low	Mid-1	Mid-2	Mid-3	High	3GPP MPR (dB)
		Channel		509202	513900	518598	523302	528000	
		Frequency (MHz)		2546.01	2569.5	2592.99	2616.51	2640	
100M	DFT-S PI/2 BPSK	1	1	23.03	23.25	23.58	23.57	23.55	0
100M	DFT-S QPSK	1	1	23.18	23.40	23.73	23.72	23.70	0
		1	137	23.13	23.35	23.68	23.67	23.65	0
		1	271	23.09	23.13	23.43	23.43	23.41	0
		135	0	22.12	22.34	22.67	22.66	22.64	1
		135	69	23.06	23.28	23.61	23.60	23.58	0
		135	138	22.08	22.30	22.63	22.62	22.60	1
		270	0	22.07	22.29	22.62	22.61	22.59	1
100M	DFT-S 16QAM	1	1	22.01	22.23	22.56	22.55	22.53	1
100M	DFT-S 64QAM	1	1	20.67	20.92	21.39	21.35	21.32	2.5
100M	DFT-S 256QAM	1	1	18.82	19.02	19.37	19.34	19.29	4.5
100M	CP QPSK	1	1	21.83	21.96	22.29	22.18	22.15	1.5

NR Conducted Power (Full)									
NR Band 77_PC2_NSA									
BW	MCS Index	RB Size	RB Offset	Low	Mid-1	Mid-2	Mid-3	High	3GPP MPR (dB)
		Channel		650000	653000	656000	659000	662000	
		Frequency (MHz)		3750	3795	3840	3885	3930	
100M	DFT-S PI/2 BPSK	1	1	25.45	26.54	26.01	25.86	25.50	0
100M	DFT-S QPSK	1	1	25.54	26.63	26.10	25.95	25.59	0
		1	137	25.06	26.15	25.62	25.47	25.11	0
		1	271	25.03	26.12	25.59	25.44	25.08	0
		135	0	24.50	25.59	25.06	24.91	24.55	1
		135	69	25.53	26.62	26.09	25.94	25.58	0
		135	138	24.48	25.57	25.04	24.89	24.53	1
		270	0	24.49	25.58	25.05	24.90	24.54	1
100M	DFT-S 16QAM	1	1	24.44	25.53	25.00	24.85	24.49	1
100M	DFT-S 64QAM	1	1	23.10	24.18	23.44	23.40	23.18	2.5
100M	DFT-S 256QAM	1	1	21.14	22.23	21.56	21.44	21.19	4.5
100M	CP QPSK	1	1	24.11	25.20	24.48	24.40	24.14	1.5

NR Conducted Power (Full)									
NR Band 77_PC3_NSA									
BW	MCS Index	RB Size	RB Offset	Low	Mid-1	Mid-2	Mid-3	High	3GPP MPR (dB)
		Channel		650000	653000	656000	659000	662000	
		Frequency (MHz)		3750	3795	3840	3885	3930	
100M	DFT-S PI/2 BPSK	1	1	23.81	23.76	23.55	23.25	23.02	0
100M	DFT-S QPSK	1	1	23.90	23.87	23.66	23.36	23.13	0
		1	137	23.68	23.64	23.50	23.17	23.04	0
		1	271	23.46	23.53	23.37	23.04	22.97	0
		135	0	22.52	22.47	22.27	21.98	21.76	1
		135	69	23.59	23.52	23.32	23.03	22.81	0
		135	138	22.39	22.34	22.14	21.85	21.63	1
		270	0	22.36	22.31	22.11	21.82	21.60	1
100M	DFT-S 16QAM	1	1	22.30	22.25	22.06	21.74	21.52	1
100M	DFT-S 64QAM	1	1	21.34	21.30	21.14	20.78	20.60	2.5
100M	DFT-S 256QAM	1	1	19.30	19.23	19.07	18.74	18.53	4.5
100M	CP QPSK	1	1	22.34	22.27	22.18	21.89	21.67	1.5

NR Conducted Power (Full)							
NR Band 78_PC2_NSA							
BW	MCS Index	RB Size	RB Offset	Low	Mid	High	3GPP MPR (dB)
		Channel			650000		
		Frequency (MHz)			3750		
100M	DFT-S PI/2 BPSK	1	1		26.03		0
100M	DFT-S QPSK	1	1		26.12		0
		1	137		25.94		0
		1	271		25.72		0
		135	0		24.88		1
		135	69		26.00		0
		135	138		24.78		1
		270	0		24.74		1
100M	DFT-S 16QAM	1	1		25.02		1
100M	DFT-S 64QAM	1	1		23.66		2.5
100M	DFT-S 256QAM	1	1		21.82		4.5
100M	CP QPSK	1	1		24.86		1.5

NR Conducted Power (Full)							
NR Band 78_PC3_NSA							
BW	MCS Index	RB Size	RB Offset	Low	Mid	High	3GPP MPR (dB)
		Channel			650000		
		Frequency (MHz)			3750		
100M	DFT-S PI/2 BPSK	1	1		23.54		0
100M	DFT-S QPSK	1	1		23.67		0
		1	137		23.35		0
		1	271		23.27		0
		135	0		22.29		1
		135	69		23.36		0
		135	138		22.16		1
		270	0		22.13		1
100M	DFT-S 16QAM	1	1		22.21		1
100M	DFT-S 64QAM	1	1		21.17		2.5
100M	DFT-S 256QAM	1	1		19.04		4.5
100M	CP QPSK	1	1		22.03		1.5

WCDMA Conducted Power (Laptop)									
Band	WCDMA II			WCDMA IV			WCDMA V		
TX Channel	9262	9400	9538	1312	1413	1513	4132	4182	4233
Rx Channel	9662	9800	9938	1537	1638	1738	4357	4407	4458
Frequency	1852.4	1880	1907.6	1712.4	1732.6	1752.6	826.4	836.4	846.6
RMC 12.2K	16.90	16.98	16.88	17.65	17.63	17.60	21.98	21.90	21.92
HSDPA Subtest-1	15.66	15.72	15.69	16.91	16.77	16.72	20.68	20.58	20.55
HSDPA Subtest-2	15.65	15.69	15.62	16.88	16.75	16.71	20.66	20.56	20.53
HSDPA Subtest-3	15.22	15.23	15.18	16.45	16.31	16.26	20.18	20.12	20.11
HSDPA Subtest-4	15.16	15.19	15.16	16.42	16.25	16.21	20.15	20.07	20.05
DC-HSDPA Subtest-1	15.54	15.51	15.54	16.84	16.72	16.65	20.58	20.53	20.52
DC-HSDPA Subtest-2	15.53	15.52	15.52	16.86	16.65	16.63	20.55	20.52	20.51
DC-HSDPA Subtest-3	15.03	15.08	15.05	16.41	16.31	16.24	20.08	20.05	20.03
DC-HSDPA Subtest-4	15.01	15.05	15.03	16.40	16.16	16.19	20.05	20.03	20.02
HSUPA Subtest-1	15.77	15.78	15.71	16.55	16.62	16.61	20.62	20.52	20.51
HSUPA Subtest-2	13.65	13.67	13.65	15.06	14.91	14.89	18.61	18.55	18.53
HSUPA Subtest-3	14.67	14.71	14.62	16.07	15.95	15.95	19.65	19.58	19.56
HSUPA Subtest-4	13.55	13.56	13.52	14.75	14.61	14.62	18.55	18.56	18.53
HSUPA Subtest-5	16.61	16.71	16.63	17.41	17.22	17.21	21.61	21.51	21.49

LTE Conducted Power (Laptop)							
LTE Band 2							
BW	MCS Index	RB Size	RB Offset	Low	Mid	High	3GPP MPR (dB)
		Channel		18700	18900	19100	
		Frequency (MHz)		1860	1880	1900	
20M	QPSK	1	0	17.85	17.80	17.81	0
		1	50	17.82	17.79	17.75	0
		1	99	17.81	17.75	17.77	0
		50	0	16.84	16.78	16.80	1
		50	25	16.78	16.72	16.74	1
		50	50	16.72	16.66	16.68	1
		100	0	16.75	16.69	16.71	1
20M	16QAM	1	0	16.72	16.66	16.68	1
		1	50	16.69	16.63	16.65	1
		1	99	16.57	16.51	16.53	1
		50	0	15.80	15.74	15.76	2
		50	25	15.68	15.62	15.64	2
		50	50	15.65	15.59	15.61	2
		100	0	15.81	15.75	15.77	2
20M	64QAM	1	0	15.68	15.62	15.64	2
		1	50	15.57	15.51	15.53	2
		1	99	15.54	15.48	15.50	2
		50	0	14.71	14.65	14.67	3
		50	25	14.67	14.61	14.63	3
		50	50	14.62	14.56	14.58	3
		100	0	14.57	14.51	14.53	3
20M	256QAM	1	0	12.23	12.26	12.20	5
		1	50	12.16	12.22	12.11	5
		1	99	12.19	12.21	12.13	5
		50	0	12.10	12.11	12.04	5
		50	25	12.14	12.17	12.11	5
		50	50	12.17	12.19	12.10	5
		100	0	12.10	12.13	12.09	5
BW	MCS Index	Channel		18675	18900	19125	3GPP MPR
		Frequency (MHz)		1857.5	1880	1902.5	
15M	QPSK	1	0	17.70	17.65	17.68	0
		1	37	17.65	17.68	17.66	0
		1	74	17.80	17.56	17.67	0
		36	0	16.64	16.75	16.72	1
		36	19	16.70	16.66	16.68	1
		36	39	16.55	16.52	16.52	1
		75	0	16.63	16.56	16.54	1
15M	16QAM	1	0	16.57	16.49	16.59	1
		1	37	16.48	16.56	16.58	1
		1	74	16.54	16.46	16.33	1
		36	0	15.67	15.63	15.63	2
		36	19	15.60	15.53	15.61	2
		36	39	15.48	15.58	15.45	2
		75	0	15.67	15.69	15.73	2
15M	64QAM	1	0	15.47	15.42	15.51	2
		1	37	15.43	15.48	15.32	2
		1	74	15.46	15.38	15.25	2
		36	0	14.56	14.62	14.59	3
		36	19	14.49	14.46	14.45	3
		36	39	14.51	14.53	14.43	3
		75	0	14.33	14.37	14.32	3
15M	256QAM	1	0	12.18	12.24	12.14	5
		1	37	12.08	12.15	12.09	5
		1	74	12.09	12.17	12.06	5
		36	0	12.03	12.10	12.01	5
		36	19	12.14	12.08	12.06	5
		36	39	12.07	12.19	12.01	5
		75	0	12.05	12.13	12.09	5



LTE Conducted Power (Laptop)							
LTE Band 2							
BW	MCS Index	Channel		18650	18900	19150	3GPP MPR
		Frequency (MHz)		1855	1880	1905	
10M	QPSK	1	0	17.64	17.60	17.62	0
		1	24	17.72	17.64	17.65	0
		1	49	17.66	17.58	17.60	0
		25	0	16.71	16.65	16.62	1
		25	12	16.65	16.53	16.57	1
		25	25	16.55	16.53	16.55	1
		50	0	16.68	16.60	16.49	1
10M	16QAM	1	0	16.64	16.55	16.57	1
		1	24	16.64	16.54	16.59	1
		1	49	16.52	16.36	16.48	1
		25	0	15.68	15.73	15.73	2
		25	12	15.45	15.57	15.40	2
		25	25	15.57	15.42	15.53	2
		50	0	15.69	15.55	15.54	2
10M	64QAM	1	0	15.48	15.44	15.61	2
		1	24	15.47	15.37	15.39	2
		1	49	15.41	15.40	15.38	2
		25	0	14.63	14.50	14.64	3
		25	12	14.62	14.59	14.43	3
		25	25	14.56	14.45	14.51	3
		50	0	14.49	14.31	14.44	3
10M	256QAM	1	0	12.22	12.23	12.19	5
		1	24	12.06	12.17	12.03	5
		1	49	12.16	12.11	12.11	5
		25	0	12.02	12.06	12.04	5
		25	12	12.06	12.17	12.11	5
		25	25	12.07	12.17	12.07	5
		50	0	12.10	12.09	12.03	5
BW	MCS Index	Channel		18625	18900	19175	3GPP MPR
		Frequency (MHz)		1852.5	1880	1907.5	
5M	QPSK	1	0	17.72	17.67	17.71	0
		1	12	17.79	17.66	17.62	0
		1	24	17.73	17.66	17.60	0
		12	0	16.68	16.64	16.65	1
		12	6	16.65	16.51	16.58	1
		12	13	16.63	16.64	16.51	1
		25	0	16.60	16.62	16.56	1
5M	16QAM	1	0	16.56	16.49	16.60	1
		1	12	16.60	16.48	16.54	1
		1	24	16.41	16.28	16.43	1
		12	0	15.62	15.70	15.60	2
		12	6	15.54	15.44	15.47	2
		12	13	15.48	15.43	15.47	2
		25	0	15.67	15.59	15.66	2
5M	64QAM	1	0	15.49	15.53	15.61	2
		1	12	15.48	15.30	15.30	2
		1	24	15.48	15.38	15.29	2
		12	0	14.57	14.65	14.59	3
		12	6	14.58	14.56	14.43	3
		12	13	14.38	14.42	14.38	3
		25	0	14.47	14.32	14.34	3
5M	256QAM	1	0	12.22	12.25	12.11	5
		1	12	12.06	12.22	12.04	5
		1	24	12.11	12.14	12.12	5
		12	0	12.02	12.01	11.94	5
		12	6	12.13	12.12	12.11	5
		12	13	12.13	12.13	12.04	5
		25	0	12.04	12.10	12.03	5

LTE Conducted Power (Laptop)							
LTE Band 2							
BW	MCS Index	Channel		18615	18900	19185	3GPP MPR
		Frequency (MHz)		1851.5	1880	1908.5	
3M	QPSK	1	0	17.75	17.70	17.73	0
		1	7	17.77	17.57	17.75	0
		1	14	17.60	17.57	17.65	0
		8	0	16.82	16.67	16.67	1
		8	3	16.72	16.64	16.57	1
		8	7	16.56	16.60	16.62	1
		15	0	16.60	16.54	16.64	1
3M	16QAM	1	0	16.55	16.47	16.56	1
		1	7	16.59	16.46	16.58	1
		1	14	16.40	16.32	16.35	1
		8	0	15.79	15.57	15.58	2
		8	3	15.58	15.41	15.42	2
		8	7	15.59	15.49	15.53	2
		15	0	15.76	15.62	15.62	2
3M	64QAM	1	0	15.58	15.46	15.55	2
		1	7	15.46	15.32	15.51	2
		1	14	15.41	15.29	15.47	2
		8	0	14.67	14.51	14.50	3
		8	3	14.51	14.42	14.43	3
		8	7	14.42	14.53	14.43	3
		15	0	14.53	14.48	14.48	3
3M	256QAM	1	0	12.17	12.17	12.15	5
		1	7	12.07	12.14	12.10	5
		1	14	12.12	12.18	12.05	5
		8	0	12.03	12.03	12.03	5
		8	3	12.13	12.08	12.09	5
		8	7	12.13	12.16	12.04	5
		15	0	12.10	12.12	12.07	5
BW	MCS Index	Channel		18607	18900	19193	3GPP MPR
		Frequency (MHz)		1850.7	1880	1909.3	
1.4M	QPSK	1	0	17.76	17.61	17.56	0
		1	2	17.78	17.72	17.71	0
		1	5	17.68	17.64	17.72	0
		3	0	16.70	16.55	16.69	0
		3	1	16.75	16.57	16.65	0
		3	3	16.48	16.51	16.49	0
		6	0	16.72	16.46	16.55	1
1.4M	16QAM	1	0	16.59	16.54	16.59	1
		1	2	16.61	16.55	16.47	1
		1	5	16.41	16.39	16.40	1
		3	0	15.75	15.70	15.64	1
		3	1	15.56	15.42	15.48	1
		3	3	15.57	15.49	15.57	1
		6	0	15.61	15.55	15.64	2
1.4M	64QAM	1	0	15.61	15.53	15.55	2
		1	2	15.50	15.36	15.47	2
		1	5	15.44	15.33	15.36	2
		3	0	14.54	14.56	14.59	2
		3	1	14.46	14.42	14.47	2
		3	3	14.49	14.42	14.50	2
		6	0	14.40	14.26	14.47	3
1.4M	256QAM	1	0	12.16	12.20	12.17	5
		1	2	12.13	12.20	12.04	5
		1	5	12.12	12.17	12.11	5
		3	0	12.10	12.08	11.96	5
		3	1	12.10	12.09	12.11	5
		3	3	12.16	12.16	12.06	5
		6	0	12.08	12.09	12.06	5

LTE Conducted Power (Laptop)							
LTE Band 4							
BW	MCS Index	RB Size	RB Offset	Low	Mid	High	3GPP MPR (dB)
		Channel		20050	20175	20300	
		Frequency (MHz)		1720	1732.5	1745	
20M	QPSK	1	0	17.81	17.74	17.75	0
		1	50	17.73	17.66	17.67	0
		1	99	17.69	17.62	17.63	0
		50	0	16.57	16.50	16.51	1
		50	25	16.55	16.48	16.49	1
		50	50	16.51	16.44	16.45	1
		100	0	16.59	16.52	16.53	1
20M	16QAM	1	0	16.56	16.49	16.50	1
		1	50	16.48	16.41	16.42	1
		1	99	16.45	16.38	16.39	1
		50	0	15.65	15.58	15.59	2
		50	25	15.62	15.55	15.56	2
		50	50	15.63	15.56	15.57	2
		100	0	15.46	15.39	15.40	2
20M	64QAM	1	0	15.68	15.61	15.62	2
		1	50	15.47	15.40	15.41	2
		1	99	15.45	15.38	15.39	2
		50	0	14.63	14.56	14.57	3
		50	25	14.58	14.51	14.52	3
		50	50	14.44	14.37	14.38	3
		100	0	14.48	14.41	14.42	3
20M	256QAM	1	0	12.18	12.24	12.19	5
		1	50	12.08	12.17	12.04	5
		1	99	12.16	12.12	12.10	5
		50	0	12.08	12.02	11.97	5
		50	25	12.10	12.17	12.03	5
		50	50	12.14	12.11	12.08	5
		100	0	12.04	12.06	12.09	5
BW	MCS Index	Channel		20025	20175	20325	3GPP MPR
		Frequency (MHz)		1717.5	1732.5	1747.5	
15M	QPSK	1	0	17.79	17.66	17.70	0
		1	37	17.73	17.56	17.58	0
		1	74	17.64	17.54	17.63	0
		36	0	16.52	16.46	16.50	1
		36	19	16.46	16.38	16.40	1
		36	39	16.47	16.43	16.41	1
		75	0	16.52	16.48	16.48	1
15M	16QAM	1	0	16.52	16.42	16.42	1
		1	37	16.44	16.37	16.39	1
		1	74	16.37	16.35	16.29	1
		36	0	15.59	15.58	15.57	2
		36	19	15.57	15.53	15.48	2
		36	39	15.59	15.55	15.51	2
		75	0	15.45	15.39	15.32	2
15M	64QAM	1	0	15.61	15.54	15.52	2
		1	37	15.37	15.40	15.39	2
		1	74	15.38	15.28	15.36	2
		36	0	14.55	14.51	14.51	3
		36	19	14.48	14.49	14.51	3
		36	39	14.42	14.37	14.34	3
		75	0	14.41	14.37	14.35	3
15M	256QAM	1	0	12.23	12.24	12.14	5
		1	37	12.14	12.15	12.05	5
		1	74	12.17	12.16	12.10	5
		36	0	12.05	12.11	12.01	5
		36	19	12.04	12.08	12.04	5
		36	39	12.13	12.19	12.05	5
		75	0	12.00	12.03	12.08	5

LTE Conducted Power (Laptop)							
LTE Band 4							
BW	MCS Index	Channel		20000	20175	20350	3GPP MPR
		Frequency (MHz)		1715	1732.5	1750	
10M	QPSK	1	0	17.73	17.70	17.72	0
		1	24	17.65	17.66	17.58	0
		1	49	17.67	17.62	17.54	0
		25	0	16.53	16.50	16.41	1
		25	12	16.49	16.41	16.42	1
		25	25	16.47	16.39	16.40	1
		50	0	16.52	16.45	16.52	1
10M	16QAM	1	0	16.50	16.47	16.42	1
		1	24	16.47	16.32	16.32	1
		1	49	16.44	16.37	16.31	1
		25	0	15.58	15.50	15.57	2
		25	12	15.61	15.55	15.52	2
		25	25	15.58	15.51	15.51	2
		50	0	15.37	15.39	15.34	2
10M	64QAM	1	0	15.68	15.57	15.58	2
		1	24	15.39	15.32	15.40	2
		1	49	15.45	15.35	15.38	2
		25	0	14.53	14.47	14.53	3
		25	12	14.56	14.49	14.42	3
		25	25	14.35	14.28	14.33	3
		50	0	14.38	14.41	14.36	3
10M	256QAM	1	0	12.14	12.19	12.19	5
		1	24	12.14	12.20	12.10	5
		1	49	12.15	12.12	12.13	5
		25	0	12.00	12.04	12.04	5
		25	12	12.14	12.14	12.09	5
		25	25	12.10	12.09	12.02	5
		50	0	12.00	12.09	11.99	5
BW	MCS Index	Channel		19975	20175	20375	3GPP MPR
		Frequency (MHz)		1712.5	1732.5	1752.5	
5M	QPSK	1	0	17.74	17.73	17.65	0
		1	12	17.71	17.65	17.58	0
		1	24	17.64	17.61	17.57	0
		12	0	16.53	16.42	16.45	1
		12	6	16.46	16.42	16.49	1
		12	13	16.48	16.40	16.44	1
		25	0	16.53	16.51	16.45	1
5M	16QAM	1	0	16.50	16.49	16.42	1
		1	12	16.41	16.36	16.37	1
		1	24	16.42	16.38	16.35	1
		12	0	15.58	15.55	15.50	2
		12	6	15.62	15.45	15.46	2
		12	13	15.58	15.48	15.54	2
		25	0	15.42	15.31	15.33	2
5M	64QAM	1	0	15.61	15.56	15.62	2
		1	12	15.47	15.32	15.36	2
		1	24	15.35	15.35	15.30	2
		12	0	14.57	14.51	14.47	3
		12	6	14.58	14.42	14.51	3
		12	13	14.42	14.34	14.37	3
		25	0	14.42	14.38	14.39	3
5M	256QAM	1	0	12.23	12.26	12.12	5
		1	12	12.09	12.16	12.04	5
		1	24	12.12	12.20	12.11	5
		12	0	12.00	12.11	11.97	5
		12	6	12.09	12.13	12.11	5
		12	13	12.07	12.16	12.00	5
		25	0	12.07	12.11	12.08	5

LTE Conducted Power (Laptop)							
LTE Band 4							
BW	MCS Index	Channel		19965	20175	20385	3GPP MPR
		Frequency (MHz)		1711.5	1732.5	1753.5	
3M	QPSK	1	0	17.78	17.67	17.74	0
		1	7	17.65	17.59	17.63	0
		1	14	17.60	17.59	17.55	0
		8	0	16.56	16.40	16.46	1
		8	3	16.46	16.43	16.46	1
		8	7	16.46	16.42	16.41	1
		15	0	16.49	16.50	16.50	1
3M	16QAM	1	0	16.52	16.45	16.40	1
		1	7	16.43	16.41	16.42	1
		1	14	16.38	16.37	16.33	1
		8	0	15.65	15.53	15.52	2
		8	3	15.56	15.49	15.52	2
		8	7	15.54	15.53	15.52	2
		15	0	15.44	15.38	15.30	2
3M	64QAM	1	0	15.63	15.54	15.55	2
		1	7	15.45	15.37	15.32	2
		1	14	15.38	15.29	15.33	2
		8	0	14.62	14.47	14.50	3
		8	3	14.54	14.41	14.52	3
		8	7	14.44	14.28	14.36	3
		15	0	14.40	14.34	14.37	3
3M	256QAM	1	0	12.15	12.24	12.11	5
		1	7	12.06	12.22	12.09	5
		1	14	12.14	12.18	12.10	5
		8	0	12.01	12.08	11.95	5
		8	3	12.09	12.15	12.02	5
		8	7	12.07	12.10	12.10	5
		15	0	12.06	12.04	12.05	5
BW	MCS Index	Channel		19957	20175	20393	3GPP MPR
		Frequency (MHz)		1710.7	1732.5	1754.3	
1.4M	QPSK	1	0	17.76	17.59	17.65	0
		1	2	17.58	17.61	17.55	0
		1	5	17.50	17.53	17.53	0
		3	0	17.45	17.32	17.39	0
		3	1	17.47	17.37	17.37	0
		3	3	17.39	17.35	17.34	0
		6	0	16.45	16.36	16.31	1
1.4M	16QAM	1	0	16.44	16.34	16.46	1
		1	2	16.25	16.21	16.35	1
		1	5	16.33	16.26	16.22	1
		3	0	16.48	16.46	16.45	1
		3	1	16.48	16.50	16.42	1
		3	3	16.55	16.44	16.47	1
		6	0	15.44	15.19	15.26	2
1.4M	64QAM	1	0	15.53	15.61	15.42	2
		1	2	15.40	15.19	15.35	2
		1	5	15.28	15.27	15.18	2
		3	0	15.58	15.41	15.49	2
		3	1	15.47	15.40	15.39	2
		3	3	15.42	15.26	15.14	2
		6	0	14.40	14.30	14.35	3
1.4M	256QAM	1	0	12.16	12.24	12.19	5
		1	2	12.07	12.21	12.04	5
		1	5	12.17	12.15	12.11	5
		3	0	12.05	12.03	11.95	5
		3	1	12.05	12.13	12.04	5
		3	3	12.07	12.19	12.10	5
		6	0	12.09	12.06	11.99	5

LTE Conducted Power (Laptop)							
LTE Band 5							
BW	MCS Index	RB Size	RB Offset	Low	Mid	High	3GPP MPR (dB)
		Channel		20450	20525	20600	
		Frequency (MHz)		829	836.5	844	
10M	QPSK	1	0	21.30	21.31	21.12	0
		1	24	20.98	21.07	21.03	0
		1	49	20.96	21.05	21.01	0
		25	0	20.38	20.47	20.43	1
		25	12	20.25	20.34	20.30	1
		25	25	20.23	20.32	20.28	1
		50	0	20.22	20.31	20.27	1
10M	16QAM	1	0	20.11	20.20	20.16	1
		1	24	20.05	20.14	20.10	1
		1	49	19.99	20.08	20.04	1
		25	0	19.33	19.42	19.38	2
		25	12	19.28	19.37	19.33	2
		25	25	19.22	19.31	19.27	2
		50	0	19.21	19.30	19.26	2
10M	64QAM	1	0	19.29	19.38	19.34	2
		1	24	19.04	19.13	19.09	2
		1	49	19.01	19.10	19.06	2
		25	0	18.44	18.47	18.46	3
		25	12	18.32	18.40	18.36	3
		25	25	18.30	18.39	18.34	3
		50	0	18.21	18.29	18.22	3
10M	256QAM	1	0	16.17	16.33	16.24	5
		1	24	16.21	16.27	16.23	5
		1	49	16.15	16.26	16.21	5
		25	0	16.01	16.16	16.04	5
		25	12	15.98	16.15	16.04	5
		25	25	16.03	16.13	16.12	5
		50	0	16.06	16.18	16.12	5
BW	MCS Index	Channel		20425	20525	20625	3GPP MPR
		Frequency (MHz)		826.5	836.5	846.5	
5M	QPSK	1	0	21.04	21.11	21.09	0
		1	12	20.98	21.07	20.99	0
		1	24	20.93	20.99	20.98	0
		12	0	20.32	20.44	20.34	1
		12	6	20.19	20.33	20.23	1
		12	13	20.15	20.31	20.19	1
		25	0	20.22	20.25	20.27	1
5M	16QAM	1	0	20.07	20.14	20.06	1
		1	12	19.97	20.08	20.00	1
		1	24	19.89	19.98	20.00	1
		12	0	19.26	19.40	19.30	2
		12	6	19.21	19.37	19.24	2
		12	13	19.15	19.27	19.25	2
		25	0	19.15	19.26	19.18	2
5M	64QAM	1	0	19.27	19.36	19.34	2
		1	12	18.96	19.10	19.03	2
		1	24	18.99	19.05	19.05	2
		12	0	18.45	18.46	18.40	3
		12	6	18.41	18.44	18.39	3
		12	13	18.38	18.39	18.35	3
		25	0	18.26	18.33	18.27	3
5M	256QAM	1	0	16.10	16.25	16.21	5
		1	12	16.14	16.21	16.23	5
		1	24	16.05	16.19	16.11	5
		12	0	15.93	16.06	15.95	5
		12	6	15.95	16.09	16.04	5
		12	13	15.96	16.13	16.09	5
		25	0	16.05	16.10	16.05	5

LTE Conducted Power (Laptop)							
LTE Band 5							
BW	MCS Index	Channel		20415	20525	20635	3GPP MPR
		Frequency (MHz)		825.5	836.5	847.5	
3M	QPSK	1	0	20.99	21.09	21.00	0
		1	7	20.89	21.01	20.97	0
		1	14	20.95	20.99	21.00	0
		8	0	20.35	20.36	20.33	1
		8	3	20.15	20.30	20.20	1
		8	7	20.14	20.25	20.27	1
		15	0	20.13	20.31	20.27	1
3M	16QAM	1	0	20.09	20.20	20.14	1
		1	7	19.95	20.13	20.03	1
		1	14	19.91	20.03	20.03	1
		8	0	19.23	19.41	19.30	2
		8	3	19.18	19.36	19.26	2
		8	7	19.22	19.23	19.22	2
		15	0	19.17	19.28	19.17	2
3M	64QAM	1	0	19.21	19.28	19.27	2
		1	7	19.03	19.12	19.05	2
		1	14	19.01	19.10	18.99	2
		8	0	18.46	18.49	18.44	3
		8	3	18.43	18.44	18.34	3
		8	7	18.41	18.43	18.30	3
		15	0	18.34	18.36	18.29	3
3M	256QAM	1	0	16.13	16.31	16.24	5
		1	7	16.16	16.23	16.14	5
		1	14	16.09	16.20	16.13	5
		8	0	15.99	16.14	15.97	5
		8	3	15.91	16.12	16.04	5
		8	7	15.93	16.08	16.05	5
		15	0	16.03	16.17	16.11	5
BW	MCS Index	Channel		20407	20525	20643	3GPP MPR
		Frequency (MHz)		824.7	836.5	848.3	
1.4M	QPSK	1	0	20.92	20.98	20.91	0
		1	2	20.93	20.92	20.89	0
		1	5	20.92	20.94	20.80	0
		3	0	20.83	20.96	21.03	0
		3	1	20.85	20.94	20.97	0
		3	3	20.93	20.88	20.86	0
		6	0	19.99	20.17	20.08	1
1.4M	16QAM	1	0	20.05	20.15	20.15	1
		1	2	19.98	20.06	19.93	1
		1	5	19.86	19.94	19.94	1
		3	0	20.17	20.32	20.32	1
		3	1	20.11	20.20	20.27	1
		3	3	20.08	20.18	20.10	1
		6	0	19.12	19.25	19.13	2
1.4M	64QAM	1	0	19.08	19.25	19.17	2
		1	2	18.93	19.04	18.97	2
		1	5	18.86	18.85	18.93	2
		3	0	19.42	19.45	19.46	2
		3	1	19.36	19.43	19.44	2
		3	3	19.41	19.45	19.44	2
		6	0	18.16	18.31	18.29	3
1.4M	256QAM	1	0	16.15	16.26	16.18	5
		1	2	16.15	16.22	16.21	5
		1	5	16.12	16.23	16.11	5
		3	0	15.92	16.14	16.01	5
		3	1	15.89	16.15	15.96	5
		3	3	15.94	16.08	16.09	5
		6	0	16.00	16.10	16.06	5

LTE Conducted Power (Laptop)							
LTE Band 7							
BW	MCS Index	RB Size	RB Offset	Low	Mid	High	3GPP MPR (dB)
		Channel		20850	21100	21350	
		Frequency (MHz)		2510	2535	2560	
20M	QPSK	1	0	17.82	17.66	17.86	0
		1	50	17.17	17.27	17.42	0
		1	99	17.08	17.18	17.33	0
		50	0	16.19	16.29	16.44	1
		50	25	16.17	16.27	16.42	1
		50	50	16.06	16.16	16.31	1
		100	0	16.14	16.24	16.39	1
20M	16QAM	1	0	16.11	16.21	16.36	1
		1	50	15.76	15.86	16.01	1
		1	99	15.41	15.51	15.66	1
		50	0	15.11	15.21	15.36	2
		50	25	15.00	15.10	15.25	2
		50	50	14.90	15.00	15.15	2
		100	0	15.03	15.13	15.28	2
20M	64QAM	1	0	14.92	15.02	15.17	2
		1	50	14.54	14.64	14.79	2
		1	99	14.23	14.33	14.48	2
		50	0	14.13	14.23	14.38	3
		50	25	14.10	14.20	14.35	3
		50	50	14.02	14.12	14.27	3
		100	0	14.13	14.23	14.38	3
20M	256QAM	1	0	12.13	12.19	12.26	5
		1	50	12.23	12.30	12.32	5
		1	99	12.17	12.19	12.26	5
		50	0	12.22	12.26	12.29	5
		50	25	12.14	12.23	12.22	5
		50	50	12.17	12.22	12.23	5
		100	0	12.15	12.25	12.26	5
BW	MCS Index	Channel		20825	21100	21375	3GPP MPR
		Frequency (MHz)		2507.5	2535	2562.5	
15M	QPSK	1	0	17.20	17.30	17.39	0
		1	37	17.08	17.23	17.39	0
		1	74	16.98	17.17	17.25	0
		36	0	16.19	16.23	16.42	1
		36	19	16.13	16.18	16.40	1
		36	39	15.98	16.12	16.22	1
		75	0	16.05	16.23	16.35	1
15M	16QAM	1	0	16.05	16.21	16.31	1
		1	37	15.68	15.86	15.94	1
		1	74	15.32	15.44	15.64	1
		36	0	15.08	15.15	15.28	2
		36	19	14.95	15.10	15.25	2
		36	39	14.80	15.00	15.05	2
		75	0	14.98	15.10	15.19	2
15M	64QAM	1	0	14.86	14.97	15.09	2
		1	37	14.47	14.59	14.79	2
		1	74	14.20	14.30	14.40	2
		36	0	14.10	14.14	14.34	3
		36	19	14.07	14.20	14.29	3
		36	39	13.94	14.04	14.23	3
		75	0	14.11	14.13	14.34	3
15M	256QAM	1	0	12.10	12.16	12.16	5
		1	37	12.20	12.28	12.26	5
		1	74	12.10	12.10	12.18	5
		36	0	12.17	12.22	12.22	5
		36	19	12.14	12.19	12.13	5
		36	39	12.17	12.16	12.17	5
		75	0	12.15	12.20	12.24	5



LTE Conducted Power (Laptop)							
LTE Band 7							
BW	MCS Index	Channel		20800	21100	21400	3GPP MPR
		Frequency (MHz)		2505	2535	2565	
10M	QPSK	1	0	17.14	17.21	17.41	0
		1	24	17.10	17.17	17.39	0
		1	49	17.05	17.12	17.26	0
		25	0	16.15	16.26	16.44	1
		25	12	16.08	16.26	16.38	1
		25	25	16.01	16.15	16.22	1
		50	0	16.14	16.22	16.39	1
10M	16QAM	1	0	16.07	16.13	16.31	1
		1	24	15.72	15.82	15.97	1
		1	49	15.36	15.43	15.58	1
		25	0	15.03	15.21	15.31	2
		25	12	14.98	15.05	15.18	2
		25	25	14.89	14.99	15.10	2
		50	0	15.00	15.08	15.28	2
10M	64QAM	1	0	14.91	14.95	15.07	2
		1	24	14.50	14.61	14.72	2
		1	49	14.16	14.24	14.45	2
		25	0	14.08	14.13	14.38	3
		25	12	14.00	14.18	14.26	3
		25	25	14.01	14.07	14.17	3
		50	0	14.13	14.21	14.33	3
10M	256QAM	1	0	12.09	12.16	12.26	5
		1	24	12.16	12.23	12.32	5
		1	49	12.17	12.12	12.19	5
		25	0	12.17	12.17	12.27	5
		25	12	12.10	12.22	12.20	5
		25	25	12.13	12.16	12.19	5
		50	0	12.11	12.19	12.24	5
BW	MCS Index	Channel		20775	21100	21425	3GPP MPR
		Frequency (MHz)		2502.5	2535	2567.5	
5M	QPSK	1	0	17.17	17.27	17.38	0
		1	12	17.07	17.23	17.42	0
		1	24	17.00	17.14	17.31	0
		12	0	16.16	16.23	16.38	1
		12	6	16.10	16.25	16.32	1
		12	13	16.05	16.07	16.25	1
		25	0	16.04	16.19	16.32	1
5M	16QAM	1	0	16.02	16.11	16.36	1
		1	12	15.68	15.85	16.00	1
		1	24	15.32	15.48	15.66	1
		12	0	15.09	15.21	15.27	2
		12	6	15.00	15.06	15.21	2
		12	13	14.82	14.97	15.11	2
		25	0	14.96	15.12	15.26	2
5M	64QAM	1	0	14.91	14.99	15.08	2
		1	12	14.53	14.63	14.69	2
		1	24	14.14	14.31	14.43	2
		12	0	14.03	14.19	14.34	3
		12	6	14.05	14.20	14.29	3
		12	13	13.96	14.03	14.25	3
		25	0	14.03	14.22	14.32	3
5M	256QAM	1	0	12.07	12.09	12.17	5
		1	12	12.13	12.29	12.30	5
		1	24	12.10	12.10	12.21	5
		12	0	12.20	12.23	12.28	5
		12	6	12.04	12.19	12.12	5
		12	13	12.17	12.21	12.17	5
		25	0	12.07	12.22	12.23	5

LTE Conducted Power (Laptop)							
LTE Band 12							
BW	MCS Index	RB Size	RB Offset	Low	Mid	High	3GPP MPR (dB)
		Channel		23060	23095	23130	
		Frequency (MHz)		704	707.5	711	
10M	QPSK	1	0	19.29	19.33	19.35	0
		1	24	19.10	18.99	19.15	0
		1	49	19.02	18.91	19.07	0
		25	0	18.01	17.90	18.06	1
		25	12	17.97	17.86	18.02	1
		25	25	17.96	17.85	18.01	1
		50	0	17.93	17.82	17.98	1
10M	16QAM	1	0	17.67	17.56	17.72	1
		1	24	17.66	17.55	17.71	1
		1	49	17.57	17.46	17.62	1
		25	0	17.07	16.96	17.12	2
		25	12	16.51	16.40	16.56	2
		25	25	16.46	16.35	16.51	2
		50	0	16.43	16.32	16.48	2
10M	64QAM	1	0	16.34	16.23	16.39	2
		1	24	16.28	16.17	16.33	2
		1	49	16.21	16.10	16.26	2
		25	0	15.66	15.55	15.71	3
		25	12	15.60	15.49	15.65	3
		25	25	15.48	15.37	15.53	3
		50	0	15.60	15.49	15.65	3
10M	256QAM	1	0	13.30	13.29	13.39	5
		1	24	13.32	13.22	13.41	5
		1	49	13.25	13.19	13.29	5
		25	0	13.13	13.09	13.22	5
		25	12	13.31	13.26	13.31	5
		25	25	13.12	13.03	13.19	5
		50	0	13.18	13.18	13.22	5
BW	MCS Index	Channel		23035	23095	23155	3GPP MPR
		Frequency (MHz)		701.5	707.5	713.5	
5M	QPSK	1	0	19.18	19.15	19.27	0
		1	12	19.31	19.23	19.31	0
		1	24	19.29	19.19	19.29	0
		12	0	18.01	17.86	18.06	1
		12	6	17.90	17.81	18.01	1
		12	13	17.91	17.75	17.99	1
		25	0	17.88	17.75	17.94	1
5M	16QAM	1	0	17.67	17.49	17.70	1
		1	12	17.56	17.46	17.61	1
		1	24	17.49	17.39	17.56	1
		12	0	17.07	16.95	17.09	2
		12	6	16.48	16.34	16.56	2
		12	13	16.42	16.27	16.47	2
		25	0	16.34	16.28	16.46	2
5M	64QAM	1	0	16.33	16.21	16.39	2
		1	12	16.18	16.08	16.27	2
		1	24	16.18	16.00	16.17	2
		12	0	15.57	15.48	15.65	3
		12	6	15.56	15.45	15.60	3
		12	13	15.47	15.32	15.45	3
		25	0	15.57	15.45	15.63	3
5M	256QAM	1	0	13.27	13.23	13.32	5
		1	12	13.28	13.14	13.37	5
		1	24	13.15	13.11	13.28	5
		12	0	13.10	12.99	13.12	5
		12	6	13.24	13.17	13.27	5
		12	13	13.12	12.97	13.09	5
		25	0	13.12	13.12	13.17	5

LTE Conducted Power (Laptop)							
LTE Band 12							
BW	MCS Index	Channel		23025	23095	23165	3GPP MPR
		Frequency (MHz)		700.5	707.5	714.5	
3M	QPSK	1	0	19.21	19.09	19.28	0
		1	7	19.09	18.92	19.06	0
		1	14	18.92	18.90	19.01	0
		8	0	18.00	17.80	17.99	1
		8	3	17.94	17.77	17.94	1
		8	7	17.93	17.79	17.99	1
		15	0	17.86	17.77	17.88	1
3M	16QAM	1	0	17.66	17.47	17.66	1
		1	7	17.58	17.54	17.71	1
		1	14	17.51	17.39	17.59	1
		8	0	17.04	16.90	17.06	2
		8	3	16.42	16.33	16.49	2
		8	7	16.42	16.35	16.50	2
		15	0	16.33	16.27	16.42	2
3M	64QAM	1	0	16.32	16.21	16.31	2
		1	7	16.25	16.17	16.25	2
		1	14	16.12	16.10	16.16	2
		8	0	15.65	15.51	15.63	3
		8	3	15.52	15.48	15.65	3
		8	7	15.46	15.31	15.50	3
		15	0	15.56	15.39	15.55	3
3M	256QAM	1	0	13.24	13.23	13.30	5
		1	7	13.29	13.16	13.38	5
		1	14	13.20	13.12	13.27	5
		8	0	13.12	13.02	13.15	5
		8	3	13.30	13.21	13.31	5
		8	7	13.06	12.94	13.10	5
		15	0	13.17	13.15	13.21	5
BW	MCS Index	Channel		23017	23095	23173	3GPP MPR
		Frequency (MHz)		699.7	707.5	715.3	
1.4M	QPSK	1	0	19.04	19.03	19.14	0
		1	2	18.89	18.81	19.06	0
		1	5	18.87	18.73	19.00	0
		3	0	19.07	18.98	19.24	0
		3	1	19.06	18.84	19.02	0
		3	3	18.92	18.80	19.04	0
		6	0	17.76	17.67	17.78	1
1.4M	16QAM	1	0	17.59	17.43	17.50	1
		1	2	17.50	17.54	17.59	1
		1	5	17.49	17.31	17.42	1
		3	0	17.98	17.84	18.04	1
		3	1	17.47	17.33	17.49	1
		3	3	17.30	17.18	17.36	1
		6	0	16.27	16.15	16.41	2
1.4M	64QAM	1	0	16.18	16.10	16.32	2
		1	2	16.21	16.00	16.16	2
		1	5	16.08	16.09	16.20	2
		3	0	16.48	16.45	16.50	2
		3	1	16.45	16.28	16.53	2
		3	3	16.26	16.19	16.47	2
		6	0	15.58	15.30	15.46	3
1.4M	256QAM	1	0	13.26	13.19	13.30	5
		1	2	13.31	13.15	13.32	5
		1	5	13.23	13.09	13.23	5
		3	0	13.03	13.05	13.18	5
		3	1	13.30	13.21	13.27	5
		3	3	13.02	12.98	13.10	5
		6	0	13.16	13.12	13.19	5

LTE Conducted Power (Laptop)							
LTE Band 13							
BW	MCS Index	RB Size	RB Offset	Mid		3GPP MPR (dB)	
		Channel		23230			
		Frequency (MHz)		782			
10M	QPSK	1	0	19.98		0	
		1	24	19.92		0	
		1	49	19.83		0	
		25	0	18.80		1	
		25	12	18.75		1	
		25	25	18.67		1	
		50	0	18.79		1	
10M	16QAM	1	0	18.68		1	
		1	24	18.59		1	
		1	49	18.43		1	
		25	0	17.95		2	
		25	12	17.90		2	
		25	25	17.81		2	
		50	0	17.76		2	
10M	64QAM	1	0	17.68		2	
		1	24	17.36		2	
		1	49	17.15		2	
		25	0	16.39		3	
		25	12	16.33		3	
		25	25	16.22		3	
		50	0	16.15		3	
10M	256QAM	1	0	14.18		5	
		1	24	14.26		5	
		1	49	14.03		5	
		25	0	13.92		5	
		25	12	13.98		5	
		25	25	13.95		5	
		50	0	14.01		5	
BW	MCS Index	Channel		23205	23230	23255	3GPP MPR
		Frequency (MHz)		779.5	782	784.5	
5M	QPSK	1	0	19.86	19.89	19.78	0
		1	12	19.78	19.81	19.70	0
		1	24	19.69	19.72	19.61	0
		12	0	18.67	18.70	18.59	1
		12	6	18.59	18.62	18.51	1
		12	13	18.48	18.51	18.40	1
		25	0	18.66	18.69	18.58	1
5M	16QAM	1	0	18.52	18.55	18.44	1
		1	12	18.46	18.49	18.38	1
		1	24	18.29	18.32	18.21	1
		12	0	17.83	17.86	17.75	2
		12	6	17.76	17.79	17.68	2
		12	13	17.60	17.63	17.52	2
		25	0	17.61	17.64	17.53	2
5M	64QAM	1	0	17.50	17.53	17.42	2
		1	12	17.20	17.23	17.12	2
		1	24	16.98	17.01	16.90	2
		12	0	16.17	16.20	16.09	3
		12	6	16.19	16.22	16.11	3
		12	13	16.10	16.13	16.02	3
		25	0	15.95	15.98	15.87	3
5M	256QAM	1	0	14.10	14.11	14.11	5
		1	12	14.25	14.17	14.20	5
		1	24	13.95	14.02	13.96	5
		12	0	13.91	13.87	13.83	5
		12	6	13.88	13.94	13.94	5
		12	13	13.93	13.92	13.86	5
		25	0	13.93	14.00	13.91	5

LTE Conducted Power (Laptop)							
LTE Band 14							
BW	MCS Index	RB Size	RB Offset	Mid		3GPP MPR (dB)	
		Channel		23330			
		Frequency (MHz)		793			
10M	QPSK	1	0	22.67		0	
		1	24	22.64		0	
		1	49	22.60		0	
		25	0	21.70		1	
		25	12	21.66		1	
		25	25	21.65		1	
		50	0	21.63		1	
10M	16QAM	1	0	21.60		1	
		1	24	21.58		1	
		1	49	21.57		1	
		25	0	20.70		2	
		25	12	20.68		2	
		25	25	20.67		2	
		50	0	20.66		2	
10M	64QAM	1	0	20.60		2	
		1	24	20.58		2	
		1	49	20.55		2	
		25	0	19.70		3	
		25	12	19.68		3	
		25	25	19.66		3	
		50	0	19.64		3	
10M	256QAM	1	0	17.11		5	
		1	24	17.08		5	
		1	49	16.99		5	
		25	0	17.01		5	
		25	12	16.94		5	
		25	25	16.98		5	
		50	0	16.95		5	
BW	MCS Index	Channel		23305	23330	23355	3GPP MPR
		Frequency (MHz)		790.5	793	795.5	
5M	QPSK	1	0	22.60	22.62	22.54	0
		1	12	22.59	22.61	22.53	0
		1	24	22.58	22.60	22.52	0
		12	0	21.64	21.66	21.58	1
		12	6	21.62	21.64	21.56	1
		12	13	21.61	21.63	21.55	1
		25	0	21.59	21.61	21.53	1
5M	16QAM	1	0	21.64	21.66	21.58	1
		1	12	21.62	21.64	21.56	1
		1	24	21.60	21.62	21.54	1
		12	0	20.63	20.65	20.57	2
		12	6	20.62	20.64	20.56	2
		12	13	20.60	20.62	20.54	2
		25	0	20.58	20.60	20.52	2
5M	64QAM	1	0	20.62	20.64	20.56	2
		1	12	20.61	20.63	20.55	2
		1	24	20.59	20.61	20.53	2
		12	0	19.62	19.64	19.56	3
		12	6	19.60	19.62	19.54	3
		12	13	19.59	19.61	19.53	3
		25	0	19.57	19.59	19.51	3
5M	256QAM	1	0	17.05	17.01	17.07	5
		1	12	17.01	17.05	17.07	5
		1	24	16.89	16.90	16.93	5
		12	0	16.92	16.95	17.00	5
		12	6	16.93	16.91	16.89	5
		12	13	16.88	16.90	16.97	5
		25	0	16.89	16.94	16.93	5

LTE Conducted Power (Laptop)							
LTE Band 17							
BW	MCS Index	RB Size	RB Offset	Low	Mid	High	3GPP MPR (dB)
		Channel		23780	23790	23800	
		Frequency (MHz)		709	710	711	
10M	QPSK	1	0	19.32	19.42	19.16	0
		1	24	19.20	19.22	19.15	0
		1	49	19.18	19.20	19.13	0
		25	0	18.26	18.28	18.21	1
		25	12	18.24	18.26	18.19	1
		25	25	18.23	18.25	18.18	1
		50	0	18.21	18.23	18.16	1
10M	16QAM	1	0	18.24	18.26	18.19	1
		1	24	18.18	18.20	18.13	1
		1	49	18.16	18.18	18.11	1
		25	0	17.24	17.26	17.19	2
		25	12	17.22	17.24	17.17	2
		25	25	17.20	17.22	17.15	2
		50	0	17.18	17.20	17.13	2
10M	64QAM	1	0	17.22	17.24	17.17	2
		1	24	17.17	17.19	17.12	2
		1	49	17.14	17.16	17.09	2
		25	0	16.22	16.24	16.17	3
		25	12	16.20	16.22	16.15	3
		25	25	16.18	16.20	16.13	3
		50	0	16.16	16.18	16.11	3
10M	256QAM	1	0	14.43	14.44	14.46	5
		1	24	14.45	14.38	14.50	5
		1	49	14.26	14.35	14.33	5
		25	0	14.11	14.29	14.19	5
		25	12	14.26	14.32	14.28	5
		25	25	14.09	14.22	14.17	5
		50	0	14.32	14.35	14.32	5
BW	MCS Index	Channel		23755	23790	23825	3GPP MPR
		Frequency (MHz)		706.5	710	713.5	
5M	QPSK	1	0	19.20	19.20	19.21	0
		1	12	19.11	19.13	19.15	0
		1	24	19.11	19.12	19.11	0
		12	0	18.26	18.26	18.11	1
		12	6	18.15	18.18	18.17	1
		12	13	18.21	18.16	18.12	1
		25	0	18.18	18.21	18.07	1
5M	16QAM	1	0	18.20	18.23	18.15	1
		1	12	18.18	18.19	18.13	1
		1	24	18.13	18.13	18.04	1
		12	0	17.20	17.18	17.14	2
		12	6	17.19	17.24	17.08	2
		12	13	17.20	17.16	17.09	2
		25	0	17.09	17.19	17.03	2
5M	64QAM	1	0	17.13	17.21	17.14	2
		1	12	17.14	17.18	17.03	2
		1	24	17.04	17.09	16.99	2
		12	0	16.20	16.15	16.16	3
		12	6	16.20	16.16	16.13	3
		12	13	16.08	16.16	16.09	3
		25	0	16.06	16.12	16.04	3
5M	256QAM	1	0	14.43	14.40	14.41	5
		1	12	14.35	14.35	14.43	5
		1	24	14.22	14.30	14.29	5
		12	0	14.01	14.26	14.14	5
		12	6	14.22	14.23	14.18	5
		12	13	13.99	14.13	14.07	5
		25	0	14.32	14.29	14.23	5

LTE Conducted Power (Laptop)							
LTE Band 25							
BW	MCS Index	RB Size	RB Offset	Low	Mid	High	3GPP MPR (dB)
		Channel		26140	26365	26590	
		Frequency (MHz)		1860	1882.5	1905	
20M	QPSK	1	0	18.00	18.02	18.07	0
		1	50	17.98	18.00	18.05	0
		1	99	17.97	17.99	18.04	0
		50	0	17.02	17.04	17.09	1
		50	25	16.94	16.96	17.01	1
		50	50	16.92	16.94	16.99	1
		100	0	16.89	16.91	16.96	1
20M	16QAM	1	0	16.99	17.01	17.06	1
		1	50	16.97	16.99	17.04	1
		1	99	16.96	16.98	17.03	1
		50	0	16.04	16.06	16.11	2
		50	25	16.02	16.04	16.09	2
		50	50	15.99	16.01	16.06	2
		100	0	15.97	15.99	16.04	2
20M	64QAM	1	0	16.04	16.06	16.11	2
		1	50	16.02	16.04	16.09	2
		1	99	16.01	16.03	16.08	2
		50	0	15.02	15.04	15.09	3
		50	25	15.00	15.02	15.07	3
		50	50	14.99	15.01	15.06	3
		100	0	14.97	14.99	15.04	3
20M	256QAM	1	0	13.24	13.28	13.38	5
		1	50	13.23	13.27	13.31	5
		1	99	13.18	13.26	13.27	5
		50	0	13.27	13.34	13.37	5
		50	25	13.25	13.28	13.34	5
		50	50	13.23	13.29	13.32	5
		100	0	13.30	13.37	13.39	5
BW	MCS Index	Channel		26115	26365	26615	3GPP MPR
		Frequency (MHz)		1857.5	1882.5	1907.5	
15M	QPSK	1	0	17.95	17.99	17.98	0
		1	37	17.94	17.97	18.02	0
		1	74	17.88	17.91	18.02	0
		36	0	16.96	16.98	17.04	1
		36	19	16.85	16.96	17.00	1
		36	39	16.89	16.93	16.90	1
		75	0	16.83	16.87	16.87	1
15M	16QAM	1	0	16.97	16.97	17.01	1
		1	37	16.93	16.98	17.03	1
		1	74	16.87	16.98	17.01	1
		36	0	15.99	15.97	16.01	2
		36	19	16.01	16.03	16.06	2
		36	39	15.95	16.01	16.06	2
		75	0	15.92	15.99	15.99	2
15M	64QAM	1	0	16.03	16.00	16.05	2
		1	37	16.01	16.02	16.02	2
		1	74	16.01	16.02	16.06	2
		36	0	14.93	15.03	15.01	3
		36	19	14.96	14.97	15.00	3
		36	39	14.97	14.95	15.06	3
		75	0	14.93	14.95	15.01	3
15M	256QAM	1	0	13.16	13.18	13.28	5
		1	37	13.16	13.17	13.21	5
		1	74	13.14	13.25	13.24	5
		36	0	13.20	13.32	13.34	5
		36	19	13.19	13.20	13.32	5
		36	39	13.15	13.20	13.25	5
		75	0	13.20	13.28	13.30	5

LTE Conducted Power (Laptop)							
LTE Band 25							
BW	MCS Index	Channel		26090	26365	26640	3GPP MPR
		Frequency (MHz)		1855	1882.5	1910	
10M	QPSK	1	0	18.00	18.02	17.98	0
		1	24	17.89	17.97	18.02	0
		1	49	17.93	17.99	18.02	0
		25	0	16.94	16.99	17.04	1
		25	12	16.90	16.86	16.93	1
		25	25	16.91	16.89	16.95	1
		50	0	16.85	16.86	16.88	1
10M	16QAM	1	0	16.97	16.97	17.02	1
		1	24	16.93	16.90	17.02	1
		1	49	16.88	16.89	17.00	1
		25	0	16.04	15.98	16.01	2
		25	12	15.97	15.96	16.05	2
		25	25	15.97	15.95	16.00	2
		50	0	15.89	15.89	16.04	2
10M	64QAM	1	0	16.01	15.98	16.06	2
		1	24	15.95	16.02	15.99	2
		1	49	15.97	16.02	16.05	2
		25	0	14.93	14.99	15.09	3
		25	12	14.97	14.99	15.03	3
		25	25	14.93	14.95	14.96	3
		50	0	14.91	14.90	14.97	3
10M	256QAM	1	0	13.18	13.19	13.36	5
		1	24	13.17	13.26	13.23	5
		1	49	13.12	13.16	13.27	5
		25	0	13.20	13.26	13.28	5
		25	12	13.18	13.21	13.31	5
		25	25	13.17	13.21	13.30	5
		50	0	13.28	13.30	13.34	5
BW	MCS Index	Channel		26065	26365	26665	3GPP MPR
		Frequency (MHz)		1852.5	1882.5	1912.5	
5M	QPSK	1	0	17.91	17.94	18.03	0
		1	12	17.92	17.90	17.96	0
		1	24	17.92	17.94	17.97	0
		12	0	16.97	16.99	17.02	1
		12	6	16.88	16.89	16.99	1
		12	13	16.84	16.92	16.89	1
		25	0	16.87	16.90	16.93	1
5M	16QAM	1	0	16.92	16.99	17.00	1
		1	12	16.91	16.97	16.95	1
		1	24	16.86	16.88	17.01	1
		12	0	16.03	15.96	16.07	2
		12	6	15.96	15.99	15.99	2
		12	13	15.99	15.99	16.00	2
		25	0	15.89	15.94	15.98	2
5M	64QAM	1	0	16.00	16.04	16.04	2
		1	12	16.02	16.00	16.02	2
		1	24	15.98	15.93	16.08	2
		12	0	14.96	14.96	15.09	3
		12	6	14.96	15.02	15.06	3
		12	13	14.99	14.97	15.02	3
		25	0	14.91	14.99	14.95	3
5M	256QAM	1	0	13.16	13.21	13.32	5
		1	12	13.16	13.22	13.29	5
		1	24	13.11	13.17	13.26	5
		12	0	13.27	13.25	13.35	5
		12	6	13.17	13.25	13.28	5
		12	13	13.19	13.21	13.25	5
		25	0	13.29	13.36	13.29	5



LTE Conducted Power (Laptop)							
LTE Band 25							
BW	MCS Index	Channel		26055	26365	26675	3GPP MPR
		Frequency (MHz)		1851.5	1882.5	1913.5	
3M	QPSK	1	0	17.92	17.97	18.00	0
		1	7	17.94	17.93	18.00	0
		1	14	17.89	17.92	17.95	0
		8	0	17.02	17.01	17.03	1
		8	3	16.88	16.92	17.00	1
		8	7	16.87	16.88	16.99	1
		15	0	16.84	16.81	16.91	1
3M	16QAM	1	0	16.94	16.94	17.03	1
		1	7	16.96	16.91	17.04	1
		1	14	16.92	16.88	17.01	1
		8	0	15.96	16.00	16.05	2
		8	3	15.96	15.99	16.00	2
		8	7	15.95	15.96	16.05	2
		15	0	15.88	15.96	15.94	2
3M	64QAM	1	0	16.03	15.98	16.10	2
		1	7	15.98	15.96	16.02	2
		1	14	15.95	15.95	16.01	2
		8	0	14.96	14.95	15.08	3
		8	3	14.91	14.96	15.06	3
		8	7	14.93	15.00	15.05	3
		15	0	14.92	14.98	14.99	3
3M	256QAM	1	0	13.18	13.28	13.33	5
		1	7	13.13	13.20	13.25	5
		1	14	13.14	13.17	13.22	5
		8	0	13.20	13.31	13.30	5
		8	3	13.17	13.20	13.31	5
		8	7	13.14	13.25	13.23	5
		15	0	13.25	13.29	13.39	5
BW	MCS Index	Channel		26047	26365	26683	3GPP MPR
		Frequency (MHz)		1850.7	1882.5	1914.3	
1.4M	QPSK	1	0	17.97	17.95	18.02	0
		1	2	17.96	17.91	18.00	0
		1	5	17.89	17.99	17.93	0
		3	0	16.96	17.00	16.99	0
		3	1	16.93	16.89	16.92	0
		3	3	16.89	16.94	16.92	0
		6	0	16.80	16.91	16.96	1
1.4M	16QAM	1	0	16.95	17.01	17.00	1
		1	2	16.96	16.95	17.02	1
		1	5	16.88	16.96	17.02	1
		3	0	15.96	16.00	16.09	1
		3	1	15.97	16.04	16.00	1
		3	3	15.95	16.01	15.99	1
		6	0	15.91	15.94	15.99	2
1.4M	64QAM	1	0	15.95	15.96	16.01	2
		1	2	16.00	16.02	16.03	2
		1	5	15.96	15.95	16.05	2
		3	0	15.01	14.97	15.01	2
		3	1	14.95	14.99	14.99	2
		3	3	14.95	14.94	14.98	2
		6	0	14.93	14.95	15.02	3
1.4M	256QAM	1	0	13.20	13.18	13.32	5
		1	2	13.19	13.26	13.24	5
		1	5	13.12	13.24	13.25	5
		3	0	13.26	13.31	13.27	5
		3	1	13.20	13.26	13.25	5
		3	3	13.15	13.27	13.25	5
		6	0	13.20	13.32	13.37	5

LTE Conducted Power (Laptop)							
LTE Band 26							
BW	MCS Index	RB Size	RB Offset	Low	Mid	High	3GPP MPR (dB)
		Channel		26765	26865	26965	
		Frequency (MHz)		821.5	831.5	841.5	
15M	QPSK	1	0	22.83	22.82	22.87	0
		1	37	22.82	22.81	22.86	0
		1	74	22.80	22.79	22.84	0
		36	0	21.79	21.78	21.83	1
		36	19	21.77	21.76	21.81	1
		36	39	21.75	21.74	21.79	1
		75	0	21.74	21.73	21.78	1
15M	16QAM	1	0	21.84	21.83	21.88	1
		1	37	21.82	21.81	21.86	1
		1	74	21.81	21.80	21.85	1
		36	0	20.84	20.83	20.88	2
		36	19	20.82	20.81	20.86	2
		36	39	20.81	20.80	20.85	2
		75	0	20.80	20.79	20.84	2
15M	64QAM	1	0	20.84	20.83	20.88	2
		1	37	20.82	20.81	20.86	2
		1	74	20.81	20.80	20.85	2
		36	0	19.80	19.79	19.84	3
		36	19	19.78	19.77	19.82	3
		36	39	19.77	19.76	19.81	3
		75	0	19.76	19.75	19.80	3
15M	256QAM	1	0	17.47	17.41	17.52	5
		1	37	17.45	17.39	17.51	5
		1	74	17.50	17.44	17.53	5
		36	0	17.41	17.34	17.49	5
		36	19	17.43	17.34	17.48	5
		36	39	17.38	17.37	17.46	5
		75	0	17.40	17.37	17.41	5
BW	MCS Index	Channel		26740	26865	26990	3GPP MPR
		Frequency (MHz)		819	831.5	844	
10M	QPSK	1	0	22.79	22.74	22.80	0
		1	24	22.81	22.76	22.83	0
		1	49	22.70	22.76	22.76	0
		25	0	21.76	21.76	21.82	1
		25	12	21.76	21.69	21.81	1
		25	25	21.69	21.65	21.72	1
		50	0	21.68	21.66	21.72	1
10M	16QAM	1	0	21.84	21.80	21.88	1
		1	24	21.75	21.81	21.81	1
		1	49	21.76	21.76	21.84	1
		25	0	20.80	20.79	20.83	2
		25	12	20.77	20.73	20.83	2
		25	25	20.76	20.73	20.80	2
		50	0	20.70	20.73	20.76	2
10M	64QAM	1	0	20.83	20.82	20.85	2
		1	24	20.73	20.78	20.79	2
		1	49	20.71	20.74	20.76	2
		25	0	19.74	19.74	19.74	3
		25	12	19.73	19.77	19.82	3
		25	25	19.68	19.75	19.76	3
		50	0	19.76	19.65	19.79	3
10M	256QAM	1	0	17.43	17.41	17.48	5
		1	24	17.41	17.31	17.50	5
		1	49	17.47	17.44	17.49	5
		25	0	17.37	17.33	17.44	5
		25	12	17.37	17.25	17.48	5
		25	25	17.37	17.35	17.44	5
		50	0	17.38	17.34	17.37	5

LTE Conducted Power (Laptop)							
LTE Band 26							
BW	MCS Index	Channel		26715	26865	27015	3GPP MPR
		Frequency (MHz)		816.5	831.5	846.5	
5M	QPSK	1	0	22.74	22.72	22.79	0
		1	12	22.79	22.79	22.81	0
		1	24	22.80	22.70	22.76	0
		12	0	21.75	21.73	21.80	1
		12	6	21.72	21.71	21.79	1
		12	13	21.70	21.73	21.77	1
		25	0	21.65	21.66	21.78	1
5M	16QAM	1	0	21.74	21.77	21.80	1
		1	12	21.73	21.81	21.82	1
		1	24	21.74	21.80	21.85	1
		12	0	20.79	20.81	20.85	2
		12	6	20.80	20.76	20.83	2
		12	13	20.76	20.79	20.79	2
		25	0	20.73	20.70	20.82	2
5M	64QAM	1	0	20.84	20.82	20.83	2
		1	12	20.75	20.71	20.80	2
		1	24	20.77	20.72	20.76	2
		12	0	19.78	19.76	19.76	3
		12	6	19.72	19.69	19.74	3
		12	13	19.76	19.75	19.72	3
		25	0	19.75	19.68	19.72	3
5M	256QAM	1	0	17.44	17.32	17.46	5
		1	12	17.45	17.32	17.43	5
		1	24	17.41	17.42	17.51	5
		12	0	17.36	17.25	17.43	5
		12	6	17.39	17.25	17.47	5
		12	13	17.38	17.35	17.38	5
		25	0	17.40	17.36	17.37	5
BW	MCS Index	Channel		26705	26865	27025	3GPP MPR
		Frequency (MHz)		815.5	831.5	847.5	
3M	QPSK	1	0	22.83	22.78	22.85	0
		1	7	22.72	22.78	22.86	0
		1	14	22.71	22.76	22.80	0
		8	0	21.72	21.68	21.78	1
		8	3	21.70	21.68	21.78	1
		8	7	21.71	21.73	21.75	1
		15	0	21.66	21.69	21.74	1
3M	16QAM	1	0	21.84	21.74	21.81	1
		1	7	21.73	21.80	21.84	1
		1	14	21.75	21.75	21.81	1
		8	0	20.74	20.77	20.79	2
		8	3	20.77	20.71	20.80	2
		8	7	20.79	20.79	20.76	2
		15	0	20.71	20.73	20.75	2
3M	64QAM	1	0	20.81	20.81	20.86	2
		1	7	20.81	20.74	20.85	2
		1	14	20.71	20.79	20.80	2
		8	0	19.75	19.71	19.83	3
		8	3	19.76	19.73	19.72	3
		8	7	19.67	19.68	19.81	3
		15	0	19.74	19.71	19.71	3
3M	256QAM	1	0	17.42	17.35	17.46	5
		1	7	17.36	17.32	17.51	5
		1	14	17.40	17.42	17.45	5
		8	0	17.31	17.25	17.46	5
		8	3	17.36	17.32	17.44	5
		8	7	17.30	17.35	17.41	5
		15	0	17.34	17.27	17.37	5

LTE Conducted Power (Laptop)							
LTE Band 26							
BW	MCS Index	Channel		26697	26865	27033	3GPP MPR
		Frequency (MHz)		814.7	831.5	848.3	
1.4M	QPSK	1	0	22.76	22.76	22.80	0
		1	2	22.76	22.71	22.86	0
		1	5	22.70	22.79	22.78	0
		3	0	21.75	21.78	21.74	0
		3	1	21.73	21.69	21.71	0
		3	3	21.74	21.65	21.69	0
		6	0	21.70	21.70	21.68	1
1.4M	16QAM	1	0	21.79	21.80	21.78	1
		1	2	21.78	21.74	21.86	1
		1	5	21.80	21.70	21.82	1
		3	0	20.82	20.77	20.79	1
		3	1	20.72	20.75	20.79	1
		3	3	20.80	20.71	20.76	1
		6	0	20.80	20.79	20.79	2
1.4M	64QAM	1	0	20.75	20.80	20.78	2
		1	2	20.74	20.75	20.83	2
		1	5	20.73	20.78	20.79	2
		3	0	19.73	19.70	19.78	2
		3	1	19.76	19.67	19.74	2
		3	3	19.72	19.75	19.81	2
		6	0	19.75	19.69	19.77	3
1.4M	256QAM	1	0	17.38	17.40	17.49	5
		1	2	17.43	17.36	17.49	5
		1	5	17.46	17.44	17.49	5
		3	0	17.33	17.28	17.42	5
		3	1	17.34	17.31	17.41	5
		3	3	17.28	17.29	17.41	5
		6	0	17.34	17.31	17.34	5

LTE Conducted Power (Laptop)							
LTE Band 30							
BW	MCS Index	RB Size	RB Offset	Mid		3GPP MPR (dB)	
		Channel		27710			
		Frequency (MHz)		2310			
10M	QPSK	1	0		20.96		0
		1	24		20.94		0
		1	49		20.92		0
		25	0		19.98		1
		25	12		19.97		1
		25	25		19.95		1
		50	0		19.94		1
10M	16QAM	1	0		19.96		1
		1	24		19.94		1
		1	49		19.93		1
		25	0		18.95		2
		25	12		18.93		2
		25	25		18.92		2
		50	0		18.90		2
10M	64QAM	1	0		18.96		2
		1	24		18.93		2
		1	49		18.92		2
		25	0		17.96		3
		25	12		17.94		3
		25	25		17.92		3
		50	0		17.90		3
10M	256QAM	1	0		15.79		5
		1	24		15.66		5
		1	49		15.67		5
		25	0		15.57		5
		25	12		15.61		5
		25	25		15.56		5
		50	0		15.52		5
BW	MCS Index	Channel		27685	27710	27735	3GPP MPR
		Frequency (MHz)		2307.5	2310	2312.5	
5M	QPSK	1	0	20.81	20.91	20.78	0
		1	12	20.78	20.88	20.75	0
		1	24	20.74	20.84	20.71	0
		12	0	19.78	19.88	19.75	1
		12	6	19.78	19.88	19.75	1
		12	13	19.80	19.90	19.77	1
		25	0	19.76	19.86	19.73	1
5M	16QAM	1	0	19.86	19.96	19.83	1
		1	12	19.83	19.93	19.80	1
		1	24	19.83	19.93	19.80	1
		12	0	18.80	18.90	18.77	2
		12	6	18.80	18.90	18.77	2
		12	13	18.81	18.91	18.78	2
		25	0	18.72	18.82	18.69	2
5M	64QAM	1	0	18.81	18.91	18.78	2
		1	12	18.74	18.84	18.71	2
		1	24	18.74	18.84	18.71	2
		12	0	17.84	17.94	17.81	3
		12	6	17.74	17.84	17.71	3
		12	13	17.78	17.88	17.75	3
		25	0	17.75	17.85	17.72	3
5M	256QAM	1	0	15.77	15.76	15.79	5
		1	12	15.66	15.56	15.60	5
		1	24	15.59	15.67	15.66	5
		12	0	15.53	15.53	15.51	5
		12	6	15.52	15.60	15.57	5
		12	13	15.49	15.51	15.53	5
		25	0	15.48	15.49	15.49	5

LTE Conducted Power (Laptop)							
LTE Band 38							
BW	MCS Index	RB Size	RB Offset	Low	Mid	High	3GPP MPR (dB)
		Channel		37850	38000	38150	
		Frequency (MHz)		2580	2595	2610	
20M	QPSK	1	0	20.20	20.05	20.18	0
		1	50	20.05	19.99	20.03	0
		1	99	20.04	19.98	20.02	0
		50	0	19.03	18.97	19.01	1
		50	25	19.00	18.94	18.98	1
		50	50	18.99	18.93	18.97	1
		100	0	18.98	18.92	18.96	1
20M	16QAM	1	0	18.06	18.00	18.04	1
		1	50	18.04	17.98	18.02	1
		1	99	18.03	17.97	18.01	1
		50	0	17.09	17.03	17.07	2
		50	25	17.06	17.00	17.04	2
		50	50	17.04	16.98	17.02	2
		100	0	17.01	16.95	16.99	2
20M	64QAM	1	0	17.06	17.00	17.04	2
		1	50	17.04	16.98	17.02	2
		1	99	17.01	16.95	16.99	2
		50	0	16.09	16.03	16.07	3
		50	25	16.07	16.01	16.05	3
		50	50	16.05	15.99	16.03	3
		100	0	16.03	15.97	16.01	3
20M	256QAM	1	0	15.31	15.22	15.18	5
		1	50	15.39	15.34	15.30	5
		1	99	15.18	15.12	15.10	5
		50	0	15.42	15.39	15.36	5
		50	25	15.39	15.38	15.37	5
		50	50	15.36	15.35	15.34	5
		100	0	15.32	15.29	15.21	5
BW	MCS Index	Channel		37825	38000	38175	3GPP MPR
		Frequency (MHz)		2577.5	2595	2612.5	
15M	QPSK	1	0	19.98	19.93	20.04	0
		1	37	19.95	19.97	19.96	0
		1	74	19.96	19.91	20.01	0
		36	0	18.96	18.92	18.95	1
		36	19	18.98	18.94	18.89	1
		36	39	18.95	18.91	18.87	1
		75	0	18.95	18.88	18.86	1
15M	16QAM	1	0	17.97	17.94	18.01	1
		1	37	18.00	17.98	17.92	1
		1	74	17.94	17.91	18.00	1
		36	0	17.07	17.02	17.04	2
		36	19	16.99	16.97	17.02	2
		36	39	16.97	16.88	16.96	2
		75	0	16.99	16.93	16.92	2
15M	64QAM	1	0	16.97	16.91	16.95	2
		1	37	17.03	16.95	16.94	2
		1	74	16.92	16.87	16.89	2
		36	0	16.04	15.99	16.03	3
		36	19	16.06	15.91	15.96	3
		36	39	16.03	15.90	15.96	3
		75	0	16.02	15.87	16.00	3
15M	256QAM	1	0	15.25	15.20	15.16	5
		1	37	15.34	15.24	15.24	5
		1	74	15.10	15.09	15.08	5
		36	0	15.34	15.33	15.29	5
		36	19	15.31	15.36	15.33	5
		36	39	15.36	15.27	15.28	5
		75	0	15.23	15.21	15.12	5

LTE Conducted Power (Laptop)							
LTE Band 38							
BW	MCS Index	Channel		37800	38000	38200	3GPP MPR
		Frequency (MHz)		2575	2595	2615	
10M	QPSK	1	0	20.01	19.91	20.04	0
		1	24	20.01	19.92	20.00	0
		1	49	19.99	19.89	19.99	0
		25	0	19.01	18.96	18.93	1
		25	12	18.90	18.91	18.96	1
		25	25	18.93	18.87	18.93	1
		50	0	18.88	18.85	18.96	1
10M	16QAM	1	0	18.04	17.96	18.04	1
		1	24	18.04	17.93	17.98	1
		1	49	18.03	17.89	17.98	1
		25	0	17.02	16.96	16.97	2
		25	12	16.96	17.00	16.94	2
		25	25	16.96	16.91	17.00	2
		50	0	16.93	16.95	16.95	2
10M	64QAM	1	0	17.04	16.90	17.02	2
		1	24	16.96	16.93	17.02	2
		1	49	17.01	16.86	16.96	2
		25	0	16.02	16.03	16.01	3
		25	12	15.98	15.91	15.98	3
		25	25	15.98	15.96	16.02	3
		50	0	15.94	15.91	15.91	3
10M	256QAM	1	0	15.25	15.19	15.10	5
		1	24	15.32	15.32	15.20	5
		1	49	15.18	15.05	15.05	5
		25	0	15.40	15.34	15.32	5
		25	12	15.33	15.34	15.28	5
		25	25	15.31	15.32	15.26	5
		50	0	15.22	15.19	15.20	5
BW	MCS Index	Channel		37775	38000	38225	3GPP MPR
		Frequency (MHz)		2572.5	2595	2617.5	
5M	QPSK	1	0	20.01	19.91	20.02	0
		1	12	20.03	19.94	19.97	0
		1	24	19.94	19.88	19.95	0
		12	0	19.03	18.93	19.00	1
		12	6	18.93	18.90	18.89	1
		12	13	18.92	18.83	18.96	1
		25	0	18.88	18.89	18.91	1
5M	16QAM	1	0	18.06	17.98	18.03	1
		1	12	18.01	17.92	18.02	1
		1	24	18.03	17.96	17.94	1
		12	0	17.06	16.99	17.03	2
		12	6	17.02	16.91	17.03	2
		12	13	16.96	16.89	16.99	2
		25	0	16.92	16.91	16.96	2
5M	64QAM	1	0	16.97	16.99	17.02	2
		1	12	17.03	16.91	16.94	2
		1	24	16.96	16.89	16.98	2
		12	0	16.07	15.94	16.00	3
		12	6	16.06	15.95	16.00	3
		12	13	16.04	15.92	16.02	3
		25	0	15.93	15.96	15.91	3
5M	256QAM	1	0	15.30	15.16	15.18	5
		1	12	15.36	15.24	15.30	5
		1	24	15.10	15.04	15.10	5
		12	0	15.36	15.36	15.28	5
		12	6	15.35	15.33	15.32	5
		12	13	15.33	15.30	15.24	5
		25	0	15.22	15.24	15.17	5

LTE Conducted Power (Laptop)							
LTE Band 40							
BW	MCS Index	RB Size	RB Offset	Low	Mid	Mid	3GPP MPR (dB)
		Channel		38750	39150	39550	
		Frequency (MHz)		2310	2350	2390	
20M	QPSK	1	0	20.13	20.39	20.07	0
		1	50	20.04	20.17	19.99	0
		1	99	20.02	20.15	19.97	0
		50	0	19.19	19.32	19.14	1
		50	25	19.17	19.30	19.12	1
		50	50	19.15	19.28	19.10	1
		100	0	19.08	19.21	19.03	1
20M	16QAM	1	0	19.05	19.18	19.00	1
		1	50	19.03	19.16	18.98	1
		1	99	19.00	19.13	18.95	1
		50	0	18.17	18.30	18.12	2
		50	25	18.15	18.28	18.10	2
		50	50	18.14	18.27	18.09	2
		100	0	18.12	18.25	18.07	2
20M	64QAM	1	0	18.05	18.18	18.00	2
		1	50	18.03	18.16	17.98	2
		1	99	18.00	18.13	17.95	2
		50	0	17.18	17.31	17.13	3
		50	25	17.15	17.28	17.10	3
		50	50	17.13	17.26	17.08	3
		100	0	17.12	17.25	17.07	3
20M	256QAM	1	0	15.17	15.18	15.07	5
		1	50	15.07	15.16	15.01	5
		1	99	14.95	15.02	14.91	5
		50	0	15.34	15.38	15.24	5
		50	25	15.31	15.36	15.28	5
		50	50	15.19	15.29	15.13	5
		100	0	15.24	15.28	15.17	5
BW	MCS Index	Channel		38725	39150	39575	3GPP MPR
		Frequency (MHz)		2307.5	2350	2392.5	
15M	QPSK	1	0	19.98	20.09	19.91	0
		1	37	19.98	20.08	19.91	0
		1	74	20.00	20.07	19.87	0
		36	0	19.18	19.31	19.06	1
		36	19	19.10	19.29	19.06	1
		36	39	19.12	19.22	19.09	1
		75	0	18.98	19.16	18.96	1
15M	16QAM	1	0	18.96	19.10	18.97	1
		1	37	19.01	19.08	18.93	1
		1	74	18.92	19.07	18.85	1
		36	0	18.12	18.20	18.11	2
		36	19	18.14	18.26	18.08	2
		36	39	18.04	18.17	18.07	2
		75	0	18.07	18.22	18.06	2
15M	64QAM	1	0	18.04	18.14	17.99	2
		1	37	18.00	18.11	17.93	2
		1	74	17.94	18.13	17.94	2
		36	0	17.14	17.21	17.09	3
		36	19	17.10	17.25	17.03	3
		36	39	17.03	17.21	17.00	3
		75	0	17.02	17.18	17.03	3
15M	256QAM	1	0	15.08	15.12	14.98	5
		1	37	15.05	15.12	15.00	5
		1	74	14.95	14.92	14.84	5
		36	0	15.32	15.31	15.20	5
		36	19	15.27	15.29	15.18	5
		36	39	15.17	15.24	15.11	5
		75	0	15.18	15.20	15.09	5



LTE Conducted Power (Laptop)							
LTE Band 40							
BW	MCS Index	Channel		38700	39150	39600	3GPP MPR
		Frequency (MHz)		2305	2350	2395	
10M	QPSK	1	0	19.96	20.10	19.98	0
		1	24	19.94	20.15	19.92	0
		1	49	19.94	20.14	19.92	0
		25	0	19.14	19.22	19.08	1
		25	12	19.07	19.22	19.09	1
		25	25	19.10	19.22	19.08	1
		50	0	18.98	19.13	18.95	1
10M	16QAM	1	0	18.95	19.09	19.00	1
		1	24	19.02	19.12	18.98	1
		1	49	18.95	19.11	18.92	1
		25	0	18.12	18.28	18.08	2
		25	12	18.13	18.28	18.04	2
		25	25	18.10	18.22	18.06	2
		50	0	18.06	18.19	18.06	2
10M	64QAM	1	0	17.97	18.17	17.91	2
		1	24	18.01	18.16	17.98	2
		1	49	18.00	18.13	17.88	2
		25	0	17.17	17.28	17.12	3
		25	12	17.06	17.19	17.05	3
		25	25	17.06	17.17	17.01	3
		50	0	17.05	17.22	17.07	3
10M	256QAM	1	0	15.15	15.15	14.97	5
		1	24	15.05	15.14	14.98	5
		1	49	14.92	14.92	14.82	5
		25	0	15.26	15.28	15.19	5
		25	12	15.23	15.26	15.20	5
		25	25	15.19	15.26	15.07	5
		50	0	15.23	15.21	15.15	5
BW	MCS Index	Channel		38675	39150	39625	3GPP MPR
		Frequency (MHz)		2302.5	2350	2397.5	
5M	QPSK	1	0	20.06	20.18	19.92	0
		1	12	19.99	20.08	19.97	0
		1	24	19.93	20.10	19.95	0
		12	0	19.14	19.24	19.12	1
		12	6	19.16	19.21	19.04	1
		12	13	19.07	19.21	19.09	1
		25	0	19.01	19.18	19.02	1
5M	16QAM	1	0	19.04	19.10	18.90	1
		1	12	18.93	19.09	18.96	1
		1	24	18.95	19.12	18.85	1
		12	0	18.14	18.30	18.12	2
		12	6	18.12	18.25	18.10	2
		12	13	18.13	18.21	18.09	2
		25	0	18.10	18.15	17.97	2
5M	64QAM	1	0	18.02	18.18	17.95	2
		1	12	17.98	18.13	17.95	2
		1	24	17.96	18.04	17.85	2
		12	0	17.08	17.24	17.03	3
		12	6	17.14	17.23	17.02	3
		12	13	17.06	17.20	16.99	3
		25	0	17.12	17.16	17.01	3
5M	256QAM	1	0	15.10	15.14	14.99	5
		1	12	15.01	15.12	14.99	5
		1	24	14.88	14.92	14.82	5
		12	0	15.25	15.36	15.22	5
		12	6	15.24	15.33	15.23	5
		12	13	15.18	15.21	15.12	5
		25	0	15.17	15.18	15.07	5

LTE Conducted Power (Laptop)									
LTE Band 41									
BW	MCS Index	RB Size	RB Offset	Low	Mid	Mid	Mid	High	3GPP MPR (dB)
		Channel		39750	40185	40620	41055	41490	
		Frequency (MHz)		2506	2549.5	2593	2636.5	2680	
20M	QPSK	1	0	17.45	17.24	17.34	17.60	17.48	0
		1	50	17.40	17.19	17.29	17.55	17.43	0
		1	99	17.36	17.15	17.25	17.51	17.39	0
		50	0	16.48	16.27	16.37	16.63	16.51	1
		50	25	16.45	16.24	16.34	16.60	16.48	1
		50	50	16.43	16.22	16.32	16.58	16.46	1
		100	0	16.36	16.15	16.25	16.51	16.39	1
20M	16QAM	1	0	16.45	16.24	16.34	16.60	16.48	1
		1	50	16.10	15.89	15.99	16.25	16.13	1
		1	99	15.75	15.54	15.64	15.90	15.78	1
		50	0	15.45	15.24	15.34	15.60	15.48	2
		50	25	15.34	15.13	15.23	15.49	15.37	2
		50	50	15.24	15.03	15.13	15.39	15.27	2
		100	0	15.37	15.16	15.26	15.52	15.40	2
20M	64QAM	1	0	15.26	15.05	15.15	15.41	15.29	2
		1	50	14.88	14.67	14.77	15.03	14.91	2
		1	99	14.57	14.36	14.46	14.72	14.60	2
		50	0	14.47	14.26	14.36	14.62	14.50	3
		50	25	14.44	14.23	14.33	14.59	14.47	3
		50	50	14.36	14.15	14.25	14.51	14.39	3
		100	0	14.47	14.26	14.36	14.62	14.50	3
20M	256QAM	1	0	12.73	12.75	12.81	12.88	12.76	5
		1	50	12.72	12.73	12.84	12.84	12.82	5
		1	99	12.74	12.77	12.83	12.91	12.79	5
		50	0	12.81	12.81	12.89	12.95	12.82	5
		50	25	12.63	12.67	12.78	12.88	12.77	5
		50	50	12.64	12.74	12.85	12.85	12.80	5
		100	0	12.59	12.61	12.74	12.84	12.65	5
BW	MCS Index	Channel		39725	40173	40620	41068	41515	3GPP MPR
		Frequency (MHz)		2503.5	2548.3	2593	2637.8	2682.5	
15M	QPSK	1	0	17.57	17.39	17.29	17.53	17.47	0
		1	37	17.50	17.43	17.28	17.49	17.38	0
		1	74	17.47	17.31	17.25	17.49	17.29	0
		36	0	16.63	16.48	16.32	16.56	16.42	1
		36	19	16.57	16.41	16.26	16.57	16.44	1
		36	39	16.56	16.44	16.25	16.58	16.45	1
		75	0	16.45	16.39	16.25	16.49	16.30	1
15M	16QAM	1	0	16.53	16.39	16.24	16.53	16.48	1
		1	37	16.22	16.10	15.93	16.21	16.04	1
		1	74	15.90	15.77	15.62	15.86	15.68	1
		36	0	15.57	15.47	15.24	15.50	15.40	2
		36	19	15.45	15.29	15.21	15.46	15.29	2
		36	39	15.31	15.19	15.04	15.33	15.20	2
		75	0	15.49	15.32	15.24	15.43	15.31	2
15M	64QAM	1	0	15.41	15.23	15.13	15.35	15.23	2
		1	37	14.94	14.84	14.70	14.94	14.84	2
		1	74	14.71	14.51	14.39	14.66	14.57	2
		36	0	14.56	14.40	14.36	14.61	14.50	3
		36	19	14.57	14.37	14.26	14.59	14.46	3
		36	39	14.44	14.29	14.18	14.41	14.34	3
		75	0	14.55	14.45	14.31	14.53	14.45	3
15M	256QAM	1	0	12.76	12.86	12.68	12.79	12.88	5
		1	37	12.81	12.78	12.65	12.80	12.76	5
		1	74	12.73	12.87	12.67	12.73	12.84	5
		36	0	12.84	12.88	12.72	12.82	12.85	5
		36	19	12.78	12.84	12.60	12.73	12.86	5
		36	39	12.77	12.79	12.70	12.79	12.80	5
		75	0	12.71	12.74	12.59	12.71	12.82	5

LTE Conducted Power (Laptop)									
LTE Band 41									
BW	MCS Index	Channel		39700	40160	40620	41080	41540	3GPP MPR
		Frequency (MHz)		2501	2547	2593	2639	2685	
10M	QPSK	1	0	17.55	17.46	17.30	17.53	17.44	0
		1	24	17.54	17.42	17.29	17.54	17.39	0
		1	49	17.42	17.33	17.20	17.49	17.31	0
		25	0	16.62	16.48	16.32	16.63	16.45	1
		25	12	16.56	16.45	16.29	16.52	16.46	1
		25	25	16.57	16.40	16.25	16.53	16.40	1
		50	0	16.48	16.38	16.16	16.41	16.32	1
10M	16QAM	1	0	16.52	16.42	16.33	16.60	16.46	1
		1	24	16.25	16.06	15.92	16.23	16.03	1
		1	49	15.88	15.74	15.56	15.89	15.68	1
		25	0	15.60	15.43	15.27	15.53	15.45	2
		25	12	15.48	15.33	15.19	15.46	15.33	2
		25	25	15.34	15.27	15.13	15.36	15.20	2
		50	0	15.52	15.32	15.20	15.43	15.36	2
10M	64QAM	1	0	15.41	15.27	15.09	15.33	15.26	2
		1	24	15.01	14.86	14.68	14.97	14.91	2
		1	49	14.63	14.58	14.39	14.69	14.51	2
		25	0	14.53	14.41	14.31	14.58	14.46	3
		25	12	14.56	14.39	14.29	14.55	14.42	3
		25	25	14.49	14.33	14.18	14.50	14.36	3
		50	0	14.58	14.41	14.35	14.54	14.40	3
10M	256QAM	1	0	12.71	12.86	12.74	12.72	12.88	5
		1	24	12.77	12.75	12.66	12.81	12.81	5
		1	49	12.82	12.87	12.71	12.74	12.88	5
		25	0	12.82	12.90	12.71	12.83	12.90	5
		25	12	12.71	12.86	12.66	12.77	12.81	5
		25	25	12.83	12.85	12.64	12.83	12.78	5
		50	0	12.64	12.80	12.58	12.73	12.75	5
BW	MCS Index	Channel		39675	40148	40620	41093	41565	3GPP MPR
		Frequency (MHz)		2498.5	2545.8	2593	2640.3	2687.5	
5M	QPSK	1	0	17.52	17.45	17.24	17.58	17.47	0
		1	12	17.45	17.39	17.27	17.50	17.35	0
		1	24	17.41	17.39	17.20	17.51	17.32	0
		12	0	16.57	16.51	16.35	16.54	16.50	1
		12	6	16.54	16.43	16.28	16.54	16.47	1
		12	13	16.51	16.40	16.28	16.49	16.40	1
		25	0	16.46	16.30	16.22	16.48	16.29	1
5M	16QAM	1	0	16.58	16.45	16.31	16.58	16.46	1
		1	12	16.22	16.04	15.91	16.17	16.12	1
		1	24	15.90	15.75	15.55	15.86	15.68	1
		12	0	15.55	15.47	15.27	15.54	15.41	2
		12	6	15.46	15.29	15.17	15.49	15.31	2
		12	13	15.31	15.19	15.10	15.38	15.24	2
		25	0	15.52	15.36	15.18	15.43	15.31	2
5M	64QAM	1	0	15.33	15.21	15.11	15.37	15.28	2
		1	12	14.97	14.87	14.73	15.03	14.85	2
		1	24	14.66	14.56	14.43	14.62	14.56	2
		12	0	14.62	14.47	14.30	14.58	14.46	3
		12	6	14.50	14.39	14.29	14.58	14.41	3
		12	13	14.50	14.35	14.16	14.50	14.37	3
		25	0	14.62	14.50	14.34	14.53	14.43	3
5M	256QAM	1	0	12.80	12.85	12.67	12.71	12.85	5
		1	12	12.76	12.74	12.67	12.79	12.75	5
		1	24	12.81	12.82	12.67	12.78	12.88	5
		12	0	12.79	12.86	12.71	12.80	12.89	5
		12	6	12.74	12.87	12.67	12.69	12.83	5
		12	13	12.85	12.81	12.73	12.75	12.79	5
		25	0	12.67	12.80	12.51	12.69	12.79	5

LTE Conducted Power (Laptop)								
LTE Band 48								
BW	MCS Index	RB Size	RB Offset	Low	Mid	Mid	Mid	3GPP MPR (dB)
		Channel		55340	55780	56210	56640	
		Frequency (MHz)		3560	3603	3647	3690	
20M	QPSK	1	0	16.81	16.73	16.99	17.19	0
		1	50	16.77	16.69	16.95	17.15	0
		1	99	16.70	16.62	16.88	17.08	0
		50	0	15.93	15.85	16.11	16.31	1
		50	25	15.84	15.76	16.02	16.22	1
		50	50	15.81	15.73	15.99	16.19	1
		100	0	15.90	15.82	16.08	16.28	1
20M	16QAM	1	0	15.72	15.64	15.90	16.10	1
		1	50	15.71	15.63	15.89	16.09	1
		1	99	15.69	15.61	15.87	16.07	1
		50	0	14.75	14.67	14.93	15.13	2
		50	25	13.74	13.66	13.92	14.12	2
		50	50	14.71	14.63	14.89	15.09	2
		100	0	14.69	14.61	14.87	15.07	2
20M	64QAM	1	0	14.24	14.16	14.42	14.62	2
		1	50	14.23	14.15	14.41	14.61	2
		1	99	14.21	14.13	14.39	14.59	2
		50	0	13.66	13.58	13.84	14.04	3
		50	25	13.65	13.57	13.83	14.03	3
		50	50	13.64	13.56	13.82	14.02	3
		100	0	13.63	13.55	13.81	14.01	3
20M	256QAM	1	0	11.89	11.89	11.95	12.03	5
		1	50	11.96	11.86	12.03	12.11	5
		1	99	11.90	11.81	11.95	12.01	5
		50	0	12.30	12.21	12.33	12.34	5
		50	25	12.33	12.31	12.33	12.33	5
		50	50	12.20	12.16	12.29	12.32	5
		100	0	12.28	12.25	12.30	12.31	5
BW	MCS Index	Channel		55315	55765	56215	56665	3GPP MPR
		Frequency (MHz)		3557.5	3602.5	3647.5	3692.5	
15M	QPSK	1	0	16.63	16.98	17.17	16.71	0
		1	37	16.60	16.95	17.05	16.65	0
		1	74	16.53	16.80	17.00	16.55	0
		36	0	15.78	16.06	16.31	15.83	1
		36	19	15.73	16.02	16.12	15.70	1
		36	39	15.64	15.90	16.12	15.73	1
		75	0	15.73	16.00	16.22	15.81	1
15M	16QAM	1	0	15.55	15.85	16.07	15.60	1
		1	37	15.59	15.80	16.07	15.60	1
		1	74	15.58	15.79	16.01	15.57	1
		36	0	14.57	14.84	15.07	14.62	2
		36	19	13.61	13.84	14.08	13.66	2
		36	39	14.57	14.82	15.00	14.62	2
		75	0	14.60	14.77	15.02	14.58	2
15M	64QAM	1	0	14.06	14.35	14.55	14.14	2
		1	37	14.14	14.38	14.58	14.12	2
		1	74	14.05	14.34	14.49	14.10	2
		36	0	13.54	13.80	14.02	13.55	3
		36	19	13.47	13.80	13.99	13.56	3
		36	39	13.53	13.74	13.95	13.48	3
		75	0	13.47	13.79	13.93	13.51	3
15M	256QAM	1	0	11.79	11.84	11.88	11.84	5
		1	37	11.91	11.79	11.87	11.86	5
		1	74	11.87	11.71	11.83	11.73	5
		36	0	12.27	12.18	12.20	12.21	5
		36	19	12.28	12.31	12.28	12.21	5
		36	39	12.20	12.14	12.15	12.07	5
		75	0	12.22	12.18	12.28	12.18	5

LTE Conducted Power (Laptop)								
LTE Band 48								
BW	MCS Index	Channel		55290	55750	56220	56690	3GPP MPR
		Frequency (MHz)		3555	3601	3648	3695	
10M	QPSK	1	0	16.69	16.99	17.16	16.63	0
		1	24	16.68	16.85	17.10	16.67	0
		1	49	16.57	16.81	17.00	16.52	0
		25	0	15.82	16.11	16.22	15.84	1
		25	12	15.70	15.99	16.15	15.70	1
		25	25	15.73	15.94	16.12	15.73	1
		50	0	15.74	16.03	16.26	15.77	1
10M	16QAM	1	0	15.61	15.84	16.08	15.54	1
		1	24	15.62	15.86	16.02	15.53	1
		1	49	15.53	15.78	16.03	15.56	1
		25	0	14.60	14.91	15.10	14.67	2
		25	12	13.65	13.91	14.12	13.63	2
		25	25	14.61	14.79	15.05	14.56	2
		50	0	14.53	14.78	15.01	14.55	2
10M	64QAM	1	0	14.11	14.38	14.52	14.15	2
		1	24	14.13	14.36	14.52	14.11	2
		1	49	14.12	14.33	14.56	14.03	2
		25	0	13.56	13.77	13.99	13.57	3
		25	12	13.53	13.75	13.94	13.54	3
		25	25	13.51	13.80	13.94	13.56	3
		50	0	13.53	13.71	13.92	13.53	3
10M	256QAM	1	0	11.82	11.86	11.79	11.84	5
		1	24	11.87	11.77	11.94	11.82	5
		1	49	11.87	11.79	11.88	11.76	5
		25	0	12.21	12.13	12.21	12.17	5
		25	12	12.25	12.27	12.26	12.29	5
		25	25	12.15	12.09	12.16	12.16	5
		50	0	12.19	12.18	12.19	12.21	5
BW	MCS Index	Channel		55265	55745	56235	56715	3GPP MPR
		Frequency (MHz)		3552.5	3600.5	3649.5	3697.5	
5M	QPSK	1	0	16.70	16.93	17.09	16.71	0
		1	12	16.65	16.94	17.11	16.60	0
		1	24	16.62	16.88	17.02	16.57	0
		12	0	15.82	16.05	16.21	15.76	1
		12	6	15.76	15.93	16.14	15.74	1
		12	13	15.67	15.93	16.13	15.69	1
		25	0	15.82	16.01	16.24	15.78	1
5M	16QAM	1	0	15.56	15.83	16.03	15.60	1
		1	12	15.58	15.86	16.08	15.57	1
		1	24	15.55	15.83	15.99	15.56	1
		12	0	14.62	14.87	15.09	14.57	2
		12	6	13.63	13.86	14.07	13.59	2
		12	13	14.62	14.88	15.00	14.57	2
		25	0	14.56	14.83	14.98	14.56	2
5M	64QAM	1	0	14.13	14.37	14.52	14.12	2
		1	12	14.10	14.33	14.60	14.13	2
		1	24	14.11	14.31	14.49	14.06	2
		12	0	13.50	13.80	13.94	13.54	3
		12	6	13.48	13.82	14.02	13.47	3
		12	13	13.51	13.78	14.02	13.51	3
		25	0	13.49	13.73	14.01	13.50	3
5M	256QAM	1	0	11.86	11.81	11.81	11.86	5
		1	12	11.89	11.78	11.96	11.86	5
		1	24	11.88	11.71	11.82	11.78	5
		12	0	12.26	12.20	12.28	12.20	5
		12	6	12.32	12.28	12.32	12.27	5
		12	13	12.11	12.15	12.20	12.14	5
		25	0	12.25	12.23	12.18	12.22	5

LTE Conducted Power (Laptop)							
LTE Band 71							
BW	MCS Index	RB Size	RB Offset	Low	Mid	Mid	3GPP MPR (dB)
		Channel		133222	133297	133372	
		Frequency (MHz)		673	680.5	688	
20M	QPSK	1	0	22.78	22.83	22.74	0
		1	50	22.76	22.81	22.72	0
		1	99	22.75	22.80	22.71	0
		50	0	21.88	21.93	21.84	1
		50	25	21.87	21.92	21.83	1
		50	50	21.85	21.90	21.81	1
		100	0	21.77	21.82	21.73	1
20M	16QAM	1	0	21.77	21.82	21.73	1
		1	50	21.75	21.80	21.71	1
		1	99	20.94	20.99	20.90	1
		50	0	20.87	20.92	20.83	2
		50	25	20.85	20.90	20.81	2
		50	50	20.82	20.87	20.78	2
		100	0	20.77	20.82	20.73	2
20M	64QAM	1	0	20.77	20.82	20.73	2
		1	50	20.76	20.81	20.72	2
		1	99	20.75	20.80	20.71	2
		50	0	19.88	19.93	19.84	3
		50	25	19.85	19.90	19.81	3
		50	50	19.83	19.88	19.79	3
		100	0	19.78	19.83	19.74	3
20M	256QAM	1	0	17.77	17.82	17.76	5
		1	50	17.68	17.72	17.66	5
		1	99	17.57	17.63	17.55	5
		50	0	17.54	17.59	17.50	5
		50	25	17.47	17.51	17.47	5
		50	50	17.40	17.44	17.39	5
		100	0	17.68	17.71	17.65	5
BW	MCS Index	Channel		133197	133297	133397	3GPP MPR
		Frequency (MHz)		670.5	680.5	690.5	
15M	QPSK	1	0	22.68	22.74	22.81	0
		1	37	22.75	22.63	22.79	0
		1	74	22.72	22.61	22.71	0
		36	0	21.87	21.79	21.90	1
		36	19	21.85	21.79	21.86	1
		36	39	21.77	21.73	21.90	1
		75	0	21.75	21.71	21.73	1
15M	16QAM	1	0	21.73	21.70	21.81	1
		1	37	21.70	21.71	21.75	1
		1	74	20.92	20.81	20.95	1
		36	0	20.77	20.76	20.91	2
		36	19	20.76	20.79	20.81	2
		36	39	20.73	20.69	20.80	2
		75	0	20.70	20.71	20.82	2
15M	64QAM	1	0	20.73	20.69	20.81	2
		1	37	20.69	20.68	20.81	2
		1	74	20.71	20.71	20.73	2
		36	0	19.87	19.77	19.89	3
		36	19	19.78	19.74	19.81	3
		36	39	19.78	19.73	19.80	3
		75	0	19.74	19.73	19.82	3
15M	256QAM	1	0	17.76	17.74	17.75	5
		1	37	17.68	17.71	17.65	5
		1	74	17.53	17.53	17.45	5
		36	0	17.49	17.53	17.50	5
		36	19	17.43	17.44	17.46	5
		36	39	17.35	17.43	17.32	5
		75	0	17.64	17.67	17.62	5

LTE Conducted Power (Laptop)							
LTE Band 71							
BW	MCS Index	Channel		133172	133297	133422	3GPP MPR
		Frequency (MHz)		668	680.5	693	
10M	QPSK	1	0	22.70	22.74	22.77	0
		1	24	22.72	22.63	22.76	0
		1	49	22.66	22.64	22.70	0
		25	0	21.80	21.77	21.83	1
		25	12	21.87	21.79	21.88	1
		25	25	21.81	21.78	21.80	1
		50	0	21.71	21.67	21.76	1
10M	16QAM	1	0	21.68	21.69	21.76	1
		1	24	21.66	21.65	21.73	1
		1	49	20.93	20.87	20.90	1
		25	0	20.82	20.82	20.86	2
		25	12	20.84	20.73	20.83	2
		25	25	20.78	20.68	20.85	2
		50	0	20.76	20.66	20.80	2
10M	64QAM	1	0	20.68	20.67	20.78	2
		1	24	20.73	20.62	20.71	2
		1	49	20.75	20.71	20.76	2
		25	0	19.80	19.79	19.87	3
		25	12	19.80	19.74	19.85	3
		25	25	19.78	19.78	19.82	3
		50	0	19.74	19.73	19.78	3
10M	256QAM	1	0	17.69	17.80	17.67	5
		1	24	17.66	17.63	17.62	5
		1	49	17.55	17.54	17.48	5
		25	0	17.48	17.59	17.43	5
		25	12	17.39	17.45	17.45	5
		25	25	17.36	17.37	17.39	5
		50	0	17.58	17.68	17.62	5
BW	MCS Index	Channel		133147	133297	133447	3GPP MPR
		Frequency (MHz)		665.5	680.5	695.5	
5M	QPSK	1	0	22.78	22.66	22.81	0
		1	12	22.73	22.65	22.74	0
		1	24	22.69	22.70	22.76	0
		12	0	21.79	21.77	21.88	1
		12	6	21.79	21.78	21.89	1
		12	13	21.80	21.76	21.88	1
		25	0	21.72	21.73	21.78	1
5M	16QAM	1	0	21.69	21.68	21.77	1
		1	12	21.72	21.68	21.74	1
		1	24	20.93	20.83	20.90	1
		12	0	20.87	20.79	20.87	2
		12	6	20.83	20.79	20.87	2
		12	13	20.74	20.74	20.86	2
		25	0	20.67	20.71	20.75	2
5M	64QAM	1	0	20.76	20.71	20.78	2
		1	12	20.66	20.69	20.78	2
		1	24	20.70	20.64	20.73	2
		12	0	19.84	19.79	19.91	3
		12	6	19.75	19.80	19.81	3
		12	13	19.83	19.74	19.83	3
		25	0	19.69	19.74	19.73	3
5M	256QAM	1	0	17.77	17.74	17.76	5
		1	12	17.67	17.66	17.61	5
		1	24	17.48	17.59	17.49	5
		12	0	17.48	17.49	17.46	5
		12	6	17.46	17.43	17.42	5
		12	13	17.36	17.42	17.39	5
		25	0	17.68	17.68	17.63	5

LTE Conducted Power (Laptop)							
LTE Band 66							
BW	MCS Index	RB Size	RB Offset	Low	Mid	High	3GPP MPR (dB)
		Channel		132072	132322	132572	
		Frequency (MHz)		1720	1745	1770	
20M	QPSK	1	0	18.21	18.24	18.20	0
		1	50	18.02	18.15	18.13	0
		1	99	17.99	18.12	18.10	0
		50	0	16.98	17.11	17.09	1
		50	25	16.96	17.09	17.07	1
		50	50	16.93	17.06	17.04	1
		100	0	16.91	17.04	17.02	1
20M	16QAM	1	0	17.03	17.16	17.14	1
		1	50	17.01	17.14	17.12	1
		1	99	17.00	17.13	17.11	1
		50	0	16.00	16.13	16.11	2
		50	25	15.97	16.10	16.08	2
		50	50	15.96	16.09	16.07	2
		100	0	15.90	16.03	16.01	2
20M	64QAM	1	0	16.03	16.16	16.14	2
		1	50	16.00	16.13	16.11	2
		1	99	15.97	16.10	16.08	2
		50	0	14.99	15.12	15.10	3
		50	25	14.98	15.11	15.09	3
		50	50	14.96	15.09	15.07	3
		100	0	14.89	15.02	15.00	3
20M	256QAM	1	0	13.17	13.33	13.27	5
		1	50	13.36	13.36	13.36	5
		1	99	13.16	13.27	13.19	5
		50	0	13.26	13.33	13.26	5
		50	25	13.21	13.34	13.27	5
		50	50	13.08	13.14	13.09	5
		100	0	13.22	13.23	13.23	5
BW	MCS Index	Channel		132047	132322	132597	3GPP MPR
		Frequency (MHz)		1717.5	1745	1772.5	
15M	QPSK	1	0	18.03	18.16	18.09	0
		1	37	17.97	18.09	18.12	0
		1	74	17.97	18.02	18.08	0
		36	0	16.90	17.09	17.06	1
		36	19	16.91	17.06	16.99	1
		36	39	16.83	17.03	17.01	1
		75	0	16.83	16.97	17.02	1
15M	16QAM	1	0	17.02	17.12	17.06	1
		1	37	16.99	17.13	17.05	1
		1	74	16.95	17.04	17.07	1
		36	0	15.96	16.03	16.04	2
		36	19	15.87	16.06	15.98	2
		36	39	15.93	16.01	15.99	2
		75	0	15.85	15.95	15.94	2
15M	64QAM	1	0	16.03	16.13	16.11	2
		1	37	15.94	16.07	16.01	2
		1	74	15.87	16.10	15.98	2
		36	0	14.99	15.02	15.03	3
		36	19	14.89	15.10	15.03	3
		36	39	14.96	14.99	15.07	3
		75	0	14.81	14.92	14.98	3
15M	256QAM	1	0	13.15	13.24	13.20	5
		1	37	13.30	13.34	13.36	5
		1	74	13.09	13.20	13.14	5
		36	0	13.20	13.26	13.18	5
		36	19	13.15	13.29	13.23	5
		36	39	13.00	13.12	13.01	5
		75	0	13.22	13.18	13.17	5



LTE Conducted Power (Laptop)							
LTE Band 66							
BW	MCS Index	Channel		132022	132322	132622	3GPP MPR
		Frequency (MHz)		1715	1745	1775	
10M	QPSK	1	0	18.02	18.15	18.15	0
		1	24	17.95	18.08	18.12	0
		1	49	17.94	18.08	18.10	0
		25	0	16.98	17.11	17.08	1
		25	12	16.90	17.06	17.04	1
		25	25	16.84	16.98	16.95	1
		50	0	16.89	17.03	17.00	1
10M	16QAM	1	0	17.02	17.16	17.08	1
		1	24	16.91	17.09	17.12	1
		1	49	16.92	17.10	17.08	1
		25	0	15.95	16.06	16.10	2
		25	12	15.95	16.04	16.03	2
		25	25	15.95	16.00	16.02	2
		50	0	15.83	15.94	15.96	2
10M	64QAM	1	0	15.95	16.11	16.09	2
		1	24	15.98	16.10	16.09	2
		1	49	15.92	16.00	16.06	2
		25	0	14.99	15.02	15.06	3
		25	12	14.90	15.11	14.99	3
		25	25	14.94	15.08	15.00	3
		50	0	14.83	14.94	14.98	3
10M	256QAM	1	0	13.13	13.27	13.23	5
		1	24	13.29	13.32	13.36	5
		1	49	13.16	13.18	13.12	5
		25	0	13.22	13.24	13.26	5
		25	12	13.20	13.26	13.24	5
		25	25	12.99	13.10	13.04	5
		50	0	13.13	13.19	13.15	5
BW	MCS Index	Channel		131997	132322	132647	3GPP MPR
		Frequency (MHz)		1712.5	1745	1777.5	
5M	QPSK	1	0	17.99	18.14	18.05	0
		1	12	17.92	18.05	18.04	0
		1	24	17.99	18.06	18.04	0
		12	0	16.96	17.02	17.02	1
		12	6	16.90	17.06	17.03	1
		12	13	16.88	16.99	16.95	1
		25	0	16.88	16.94	16.97	1
5M	16QAM	1	0	16.99	17.16	17.05	1
		1	12	16.96	17.08	17.02	1
		1	24	16.98	17.07	17.07	1
		12	0	15.96	16.09	16.05	2
		12	6	15.92	16.01	16.03	2
		12	13	15.93	16.06	16.03	2
		25	0	15.85	16.00	15.93	2
5M	64QAM	1	0	16.03	16.10	16.11	2
		1	12	15.90	16.09	16.05	2
		1	24	15.94	16.08	16.06	2
		12	0	14.90	15.07	15.07	3
		12	6	14.90	15.05	15.05	3
		12	13	14.94	15.01	14.99	3
		25	0	14.89	14.98	14.91	3
5M	256QAM	1	0	13.10	13.27	13.26	5
		1	12	13.35	13.33	13.31	5
		1	24	13.10	13.21	13.11	5
		12	0	13.23	13.27	13.24	5
		12	6	13.11	13.25	13.19	5
		12	13	13.07	13.10	13.03	5
		25	0	13.18	13.16	13.22	5

LTE Conducted Power (Laptop)							
LTE Band 66							
BW	MCS Index	Channel		131987	132322	132657	3GPP MPR
		Frequency (MHz)		1711.5	1745	1778.5	
3M	QPSK	1	0	18.04	18.13	18.08	0
		1	7	18.00	18.13	18.03	0
		1	14	17.92	18.04	18.05	0
		8	0	16.92	17.03	17.05	1
		8	3	16.96	17.05	17.02	1
		8	7	16.90	17.06	16.99	1
		15	0	16.86	16.98	16.99	1
3M	16QAM	1	0	17.00	17.09	17.09	1
		1	7	16.94	17.08	17.03	1
		1	14	16.94	17.03	17.05	1
		8	0	15.93	16.09	16.06	2
		8	3	15.96	16.07	16.06	2
		8	7	15.94	16.04	16.01	2
		15	0	15.87	16.03	15.96	2
3M	64QAM	1	0	15.96	16.14	16.12	2
		1	7	15.92	16.06	16.01	2
		1	14	15.91	16.02	16.05	2
		8	0	14.98	15.08	15.04	3
		8	3	14.94	15.05	15.09	3
		8	7	14.86	15.00	15.02	3
		15	0	14.83	14.97	14.95	3
3M	256QAM	1	0	13.09	13.28	13.25	5
		1	7	13.36	13.28	13.31	5
		1	14	13.09	13.26	13.12	5
		8	0	13.19	13.27	13.18	5
		8	3	13.13	13.30	13.24	5
		8	7	13.05	13.05	13.09	5
		15	0	13.12	13.21	13.18	5
BW	MCS Index	Channel		131979	132322	132665	3GPP MPR
		Frequency (MHz)		1710.7	1745	1779.3	
1.4M	QPSK	1	0	18.04	18.13	18.08	0
		1	2	17.94	18.10	18.09	0
		1	5	17.95	18.10	18.02	0
		3	0	16.94	17.01	17.04	0
		3	1	16.88	17.08	16.99	0
		3	3	16.92	16.97	17.03	0
		6	0	16.91	16.99	17.00	1
1.4M	16QAM	1	0	16.96	17.10	17.13	1
		1	2	16.91	17.12	17.05	1
		1	5	16.97	17.04	17.01	1
		3	0	15.99	16.05	16.09	1
		3	1	15.96	16.01	16.07	1
		3	3	15.89	16.04	16.02	1
		6	0	15.85	16.02	15.98	2
1.4M	64QAM	1	0	15.95	16.10	16.11	2
		1	2	15.90	16.08	16.05	2
		1	5	15.89	16.04	16.02	2
		3	0	14.98	15.06	15.05	2
		3	1	14.97	15.05	15.03	2
		3	3	14.96	15.06	14.99	2
		6	0	14.79	14.93	15.00	3
1.4M	256QAM	1	0	13.07	13.30	13.19	5
		1	2	13.32	13.31	13.27	5
		1	5	13.11	13.26	13.12	5
		3	0	13.22	13.26	13.26	5
		3	1	13.18	13.34	13.18	5
		3	3	13.08	13.10	13.05	5
		6	0	13.16	13.18	13.19	5

NR Conducted Power (Laptop)							
NR Band 2_SA							
BW	MCS Index	RB Size	RB Offset	Low	Mid	High	3GPP MPR (dB)
		Channel		372000	376000	380000	
		Frequency (MHz)		1860	1880	1900	
20M	DFT-S PI/2 BPSK	1	1	16.33	16.41	16.35	0
20M	DFT-S QPSK	1	1	16.44	16.48	16.43	0
		1	53	15.90	15.93	15.87	0
		1	104	15.86	15.89	15.83	0
		50	0	15.39	15.42	15.36	1
		50	28	15.86	15.89	15.83	0
		50	56	15.39	15.42	15.36	1
100	0	15.44	15.47	15.41	1		
20M	DFT-S 16QAM	1	1	15.33	15.37	15.34	1
20M	DFT-S 64QAM	1	1	13.83	13.87	13.84	2.5
20M	DFT-S 256QAM	1	1	11.84	11.88	11.85	4.5
20M	CP QPSK	1	1	14.87	14.91	14.88	1.5
BW	MCS Index	Channel		371500	376000	380500	3GPP MPR
		Frequency (MHz)		1857.5	1880	1902.5	
15M	DFT-S PI/2 BPSK	1	1	16.31	16.33	16.35	0
15M	DFT-S QPSK	1	1	16.40	16.40	16.34	0
		1	40	15.86	15.86	15.85	0
		1	77	15.84	15.88	15.73	0
		36	0	15.32	15.36	15.34	1
		36	22	15.77	15.87	15.79	0
		36	43	15.31	15.40	15.28	1
75	0	15.35	15.45	15.41	1		
15M	DFT-S 16QAM	1	1	15.29	15.31	15.26	1
15M	DFT-S 64QAM	1	1	13.76	13.84	13.80	2.5
15M	DFT-S 256QAM	1	1	11.80	11.80	11.76	4.5
15M	CP QPSK	1	1	14.84	14.91	14.78	1.5

## NR Conducted Power (Laptop)

### NR Band 2\_SA

BW	MCS Index	Channel		371000	376000	381000	3GPP MPR
		Frequency (MHz)		1855	1880	1905	
10M	DFT-S PI/2 BPSK	1	1	16.28	16.36	16.30	0
10M	DFT-S QPSK	1	1	16.34	16.40	16.36	0
		1	26	15.90	15.88	15.83	0
		1	50	15.84	15.87	15.75	0
		25	0	15.34	15.40	15.27	1
		25	14	15.77	15.83	15.82	0
		25	27	15.39	15.41	15.26	1
10M	DFT-S 16QAM	1	1	15.25	15.29	15.25	1
10M	DFT-S 64QAM	1	1	13.82	13.77	13.74	2.5
10M	DFT-S 256QAM	1	1	11.79	11.85	11.81	4.5
10M	CP QPSK	1	1	14.80	14.89	14.86	1.5
BW	MCS Index	Channel		370500	376000	381500	3GPP MPR
		Frequency (MHz)		1852.5	1880	1907.5	
5M	DFT-S PI/2 BPSK	1	1	16.25	16.40	16.27	0
5M	DFT-S QPSK	1	1	16.37	16.44	16.40	0
		1	13	15.86	15.83	15.86	0
		1	23	15.79	15.86	15.76	0
		12	0	15.32	15.37	15.28	1
		12	7	15.82	15.81	15.80	0
		12	13	15.38	15.38	15.29	1
5M	DFT-S 16QAM	1	1	15.24	15.37	15.29	1
5M	DFT-S 64QAM	1	1	13.82	13.83	13.84	2.5
5M	DFT-S 256QAM	1	1	11.78	11.87	11.81	4.5
5M	CP QPSK	1	1	14.78	14.86	14.81	1.5

NR Conducted Power (Laptop)							
NR Band 5_SA							
BW	MCS Index	RB Size	RB Offset	Low	Mid	High	3GPP MPR (dB)
		Channel		166800	167300	167800	
		Frequency (MHz)		834	836.5	839	
20M	DFT-S PI/2 BPSK	1	1	19.10	19.31	19.09	0
20M	DFT-S QPSK	1	1	19.14	19.36	19.15	0
		1	53	19.12	19.33	19.11	0
		1	104	19.11	19.32	19.10	0
		50	0	18.21	18.42	18.20	1
		50	28	19.13	19.34	19.12	0
		50	56	18.32	18.53	18.31	1
100	0	18.35	18.56	18.34	1		
20M	DFT-S 16QAM	1	1	18.14	18.36	18.14	1
20M	DFT-S 64QAM	1	1	16.64	16.86	16.64	2.5
20M	DFT-S 256QAM	1	1	14.64	14.86	14.64	4.5
20M	CP QPSK	1	1	17.64	17.86	17.64	1.5
BW	MCS Index	Channel		166300	167300	168300	3GPP MPR
		Frequency (MHz)		831.5	836.5	841.5	
15M	DFT-S PI/2 BPSK	1	1	19.07	19.24	19.07	0
15M	DFT-S QPSK	1	1	19.07	19.31	19.13	0
		1	40	19.12	19.28	19.02	0
		1	77	19.04	19.26	19.10	0
		36	0	18.17	18.35	18.19	1
		36	22	19.03	19.27	19.03	0
		36	43	18.30	18.52	18.24	1
75	0	18.33	18.46	18.28	1		
15M	DFT-S 16QAM	1	1	18.06	18.32	18.07	1
15M	DFT-S 64QAM	1	1	16.62	16.80	16.54	2.5
15M	DFT-S 256QAM	1	1	14.60	14.81	14.61	4.5
15M	CP QPSK	1	1	17.59	17.76	17.57	1.5

## NR Conducted Power (Laptop)

### NR Band 5\_SA

BW	MCS Index	Channel		165800	167300	168800	3GPP MPR
		Frequency (MHz)		829	836.5	844	
10M	DFT-S PI/2 BPSK	1	1	19.02	19.22	19.08	0
10M	DFT-S QPSK	1	1	19.10	19.34	19.08	0
		1	26	19.06	19.29	19.07	0
		1	50	19.08	19.22	19.05	0
		25	0	18.21	18.39	18.16	1
		25	14	19.07	19.30	19.10	0
		25	27	18.31	18.45	18.31	1
50	0	18.26	18.52	18.30	1		
10M	DFT-S 16QAM	1	1	18.13	18.28	18.05	1
10M	DFT-S 64QAM	1	1	16.56	16.84	16.59	2.5
10M	DFT-S 256QAM	1	1	14.61	14.78	14.59	4.5
10M	CP QPSK	1	1	17.58	17.77	17.59	1.5
BW	MCS Index	Channel		165300	167300	169300	3GPP MPR
		Frequency (MHz)		826.5	836.5	846.5	
5M	DFT-S PI/2 BPSK	1	1	19.03	19.30	19.08	0
5M	DFT-S QPSK	1	1	19.05	19.27	19.13	0
		1	13	19.04	19.27	19.04	0
		1	23	19.06	19.27	19.05	0
		12	0	18.20	18.40	18.13	1
		12	7	19.09	19.32	19.07	0
		12	13	18.23	18.52	18.26	1
25	0	18.28	18.54	18.29	1		
5M	DFT-S 16QAM	1	1	18.09	18.35	18.12	1
5M	DFT-S 64QAM	1	1	16.57	16.82	16.59	2.5
5M	DFT-S 256QAM	1	1	14.62	14.76	14.54	4.5
5M	CP QPSK	1	1	17.61	17.85	17.62	1.5

NR Conducted Power (Laptop)							
NR Band 7_SA							
BW	MCS Index	Channel		502000	507000	512000	3GPP MPR
		Frequency (MHz)		2510	2535	2560	
20M	DFT-S PI/2 BPSK	1	1	15.17	15.28	15.14	0
20M	DFT-S QPSK	1	1	15.22	15.32	15.17	0
		1	53	15.17	15.26	15.15	0
		1	104	15.15	15.24	15.13	0
		50	0	14.22	14.29	14.18	1
		50	28	15.15	15.31	15.10	0
		50	56	14.22	14.30	14.19	1
100	0	14.25	14.31	14.20	1		
20M	DFT-S 16QAM	1	1	14.25	14.32	14.19	1
20M	DFT-S 64QAM	1	1	12.71	12.80	12.66	2.5
20M	DFT-S 256QAM	1	1	10.77	10.84	10.66	4.5
20M	CP QPSK	1	1	13.72	13.82	13.67	1.5
BW	MCS Index	Channel		501500	507000	512500	3GPP MPR
		Frequency (MHz)		2507.5	2535	2562.5	
15M	DFT-S PI/2 BPSK	1	1	15.07	15.19	15.06	0
15M	DFT-S QPSK	1	1	15.17	15.29	15.14	0
		1	40	15.08	15.16	15.13	0
		1	77	15.14	15.15	15.12	0
		36	0	14.21	14.23	14.12	1
		36	22	15.21	15.29	15.16	0
		36	43	14.21	14.20	14.12	1
75	0	14.24	14.28	14.19	1		
15M	DFT-S 16QAM	1	1	14.19	14.27	14.17	1
15M	DFT-S 64QAM	1	1	12.62	12.79	12.57	2.5
15M	DFT-S 256QAM	1	1	10.74	10.80	10.57	4.5
15M	CP QPSK	1	1	13.69	13.74	13.61	1.5

NR Conducted Power (Laptop)							
NR Band 7_SA							
BW	MCS Index	Channel		501000	507000	513000	3GPP MPR
		Frequency (MHz)		2505	2535	2565	
10M	DFT-S PI/2 BPSK	1	1	15.10	15.22	15.09	0
10M	DFT-S QPSK	1	1	15.19	15.31	15.08	0
		1	26	15.11	15.26	15.14	0
		1	50	15.05	15.23	15.04	0
		25	0	14.18	14.25	14.08	1
		25	14	15.20	15.23	15.16	0
		25	27	14.21	14.30	14.19	1
10M	DFT-S 16QAM	1	1	14.24	14.22	14.11	1
10M	DFT-S 64QAM	1	1	12.64	12.80	12.66	2.5
10M	DFT-S 256QAM	1	1	10.67	10.76	10.62	4.5
10M	CP QPSK	1	1	13.72	13.76	13.65	1.5
BW	MCS Index	Channel		500500	507000	513500	3GPP MPR
		Frequency (MHz)		2502.5	2535	2567.5	
5M	DFT-S PI/2 BPSK	1	1	15.13	15.20	15.07	0
5M	DFT-S QPSK	1	1	15.19	15.22	15.09	0
		1	13	15.14	15.17	15.11	0
		1	23	15.07	15.17	15.09	0
		12	0	14.18	14.19	14.15	1
		12	7	15.17	15.29	15.17	0
		12	13	14.20	14.25	14.15	1
5M	DFT-S 16QAM	1	1	14.25	14.29	14.09	1
5M	DFT-S 64QAM	1	1	12.69	12.72	12.62	2.5
5M	DFT-S 256QAM	1	1	10.67	10.82	10.59	4.5
5M	CP QPSK	1	1	13.69	13.82	13.65	1.5



NR Conducted Power (Laptop)							
NR Band 25_SA							
BW	MCS Index	Channel		372000	376500	381000	3GPP MPR
		Frequency (MHz)		1860	1882.5	1905	
20M	DFT-S PI/2 BPSK	1	1	16.42	16.41	16.48	0
20M	DFT-S QPSK	1	1	16.45	16.43	16.49	0
		1	53	15.67	15.65	15.71	0
		1	104	15.58	15.56	15.62	0
		50	0	14.66	14.64	14.70	1
		50	28	15.71	15.69	15.75	0
		50	56	14.55	14.53	14.59	1
100	0	14.60	14.58	14.64	1		
20M	DFT-S 16QAM	1	1	15.48	15.33	15.49	1
20M	DFT-S 64QAM	1	1	13.94	13.91	13.98	2.5
20M	DFT-S 256QAM	1	1	12.00	11.95	11.98	4.5
20M	CP QPSK	1	1	14.95	14.93	14.99	1.5
BW	MCS Index	Channel		371500	376500	381500	3GPP MPR
		Frequency (MHz)		1857.5	1882.5	1907.5	
15M	DFT-S PI/2 BPSK	1	1	16.36	16.37	16.39	0
15M	DFT-S QPSK	1	1	16.45	16.34	16.41	0
		1	40	15.60	15.61	15.62	0
		1	77	15.50	15.55	15.52	0
		36	0	14.66	14.60	14.67	1
		36	22	15.62	15.69	15.74	0
		36	43	14.55	14.43	14.55	1
75	0	14.53	14.54	14.60	1		
15M	DFT-S 16QAM	1	1	15.41	15.28	15.47	1
15M	DFT-S 64QAM	1	1	13.87	13.90	13.90	2.5
15M	DFT-S 256QAM	1	1	11.91	11.94	11.91	4.5
15M	CP QPSK	1	1	14.85	14.93	14.89	1.5

NR Conducted Power (Laptop)							
NR Band 25_SA							
BW	MCS Index	Channel		371000	376500	382000	3GPP MPR
		Frequency (MHz)		1855	1882.5	1910	
10M	DFT-S PI/2 BPSK	1	1	16.34	16.41	16.38	0
10M	DFT-S QPSK	1	1	16.42	16.43	16.39	0
		1	26	15.66	15.60	15.65	0
		1	50	15.56	15.51	15.58	0
		25	0	14.58	14.64	14.62	1
		25	14	15.63	15.69	15.73	0
		25	27	14.48	14.52	14.57	1
10M	DFT-S 16QAM	1	1	15.40	15.28	15.39	1
10M	DFT-S 64QAM	1	1	13.84	13.84	13.91	2.5
10M	DFT-S 256QAM	1	1	11.93	11.95	11.98	4.5
10M	CP QPSK	1	1	14.92	14.90	14.97	1.5
BW	MCS Index	Channel		370500	376500	382500	3GPP MPR
		Frequency (MHz)		1852.5	1882.5	1912.5	
5M	DFT-S PI/2 BPSK	1	1	16.38	16.32	16.44	0
5M	DFT-S QPSK	1	1	16.45	16.40	16.44	0
		1	13	15.58	15.59	15.67	0
		1	23	15.54	15.49	15.60	0
		12	0	14.58	14.59	14.67	1
		12	7	15.63	15.65	15.72	0
		12	13	14.49	14.52	14.55	1
5M	DFT-S 16QAM	1	1	15.47	15.24	15.48	1
5M	DFT-S 64QAM	1	1	13.91	13.84	13.97	2.5
5M	DFT-S 256QAM	1	1	11.98	11.91	11.97	4.5
5M	CP QPSK	1	1	14.87	14.90	14.92	1.5

NR Conducted Power (Laptop)							
NR Band 30_SA							
BW	MCS Index	RB Size	RB Offset		Mid		3GPP MPR (dB)
		Channel			462000		
		Frequency (MHz)			2310		
10M	DFT-S PI/2 BPSK	1	1		17.78		0
10M	DFT-S QPSK	1	1		18.24		0
		1	26		17.81		0
		1	50		17.79		0
		25	0		17.12		1
		25	14		17.81		0
		25	27		17.06		1
10M	DFT-S 16QAM	1	1		16.72		1
10M	DFT-S 64QAM	1	1		15.30		2.5
10M	DFT-S 256QAM	1	1		13.34		4.5
10M	CP QPSK	1	1		16.32		1.5
BW	MCS Index	Channel		461500	462000	462500	3GPP MPR
		Frequency (MHz)		2307.5	2310	2312.5	
5M	DFT-S PI/2 BPSK	1	1	17.70	17.68	17.77	0
5M	DFT-S QPSK	1	1	17.78	17.79	17.76	0
		1	13	17.75	17.80	17.74	0
		1	23	17.70	17.75	17.77	0
		12	0	17.11	17.06	17.07	1
		12	7	17.71	17.75	17.76	0
		12	13	16.97	17.02	17.01	1
5M	DFT-S 16QAM	1	1	16.72	16.68	16.63	1
5M	DFT-S 64QAM	1	1	15.28	15.28	15.21	2.5
5M	DFT-S 256QAM	1	1	13.31	13.28	13.28	4.5
5M	CP QPSK	1	1	16.22	16.25	16.30	1.5

NR Conducted Power (Laptop)							
NR Band 66_SA							
BW	MCS Index	RB Size	RB Offset	Low	Mid	High	3GPP MPR (dB)
		Channel		346000	349000	352000	
		Frequency (MHz)		1730	1745	1760	
40M	DFT-S PI/2 BPSK	1	1	16.68	16.91	16.71	0
40M	DFT-S QPSK	1	1	16.75	16.99	16.78	0
		1	108	16.54	16.57	16.55	0
		1	214	16.93	16.93	16.89	0
		108	0	15.89	15.99	15.95	1
		108	54	16.26	16.34	16.24	0
		108	108	15.09	15.15	15.09	1
40M	DFT-S 16QAM	1	1	15.78	15.89	15.80	1
40M	DFT-S 64QAM	1	1	14.24	14.47	14.27	2.5
40M	DFT-S 256QAM	1	1	12.30	12.51	12.27	4.5
40M	CP QPSK	1	1	15.25	15.49	15.28	1.5
BW	MCS Index	Channel		345000	349000	353000	3GPP MPR
		Frequency (MHz)		1725	1745	1765	
30M	DFT-S PI/2 BPSK						
30M	DFT-S QPSK						
30M	DFT-S 16QAM						
30M	DFT-S 64QAM						
30M	DFT-S 256QAM						
30M	CP QPSK						
30M	CP QPSK						

NR Conducted Power (Laptop)							
NR Band 66_SA							
BW	MCS Index	Channel		344000	349000	354000	3GPP MPR
		Frequency (MHz)		1720	1745	1770	
20M	DFT-S PI/2 BPSK	1	1	16.67	16.86	16.70	0
20M	DFT-S QPSK	1	1	16.65	16.89	16.72	0
		1	53	16.47	16.49	16.52	0
		1	104	16.92	16.89	16.86	0
		50	0	15.81	15.99	15.94	1
		50	28	16.24	16.28	16.16	0
		50	56	15.07	15.14	15.08	1
100	0	15.11	15.10	15.08	1		
20M	DFT-S 16QAM	1	1	15.74	15.82	15.75	1
20M	DFT-S 64QAM	1	1	14.23	14.40	14.20	2.5
20M	DFT-S 256QAM	1	1	12.20	12.43	12.22	4.5
20M	CP QPSK	1	1	15.18	15.40	15.25	1.5
BW	MCS Index	Channel		343500	349000	354500	3GPP MPR
		Frequency (MHz)		1717.5	1745	1772.5	
15M	DFT-S PI/2 BPSK	1	1	16.59	16.87	16.61	0
15M	DFT-S QPSK	1	1	16.72	16.92	16.74	0
		1	40	16.53	16.48	16.49	0
		1	77	16.90	16.93	16.84	0
		36	0	15.79	15.95	15.95	1
		36	22	16.16	16.29	16.22	0
		36	43	15.04	15.14	15.07	1
75	0	15.12	15.10	15.04	1		
15M	DFT-S 16QAM	1	1	15.68	15.83	15.76	1
15M	DFT-S 64QAM	1	1	14.22	14.46	14.17	2.5
15M	DFT-S 256QAM	1	1	12.27	12.51	12.19	4.5
15M	CP QPSK	1	1	15.15	15.48	15.27	1.5

NR Conducted Power (Laptop)							
NR Band 66_SA							
BW	MCS Index	Channel		343000	349000	355000	3GPP MPR
		Frequency (MHz)		1715	1745	1775	
10M	DFT-S PI/2 BPSK	1	1	16.67	16.90	16.65	0
10M	DFT-S QPSK	1	1	16.71	16.89	16.78	0
		1	26	16.47	16.49	16.45	0
		1	50	16.85	16.89	16.84	0
		25	0	15.86	15.97	15.89	1
		25	14	16.20	16.26	16.18	0
		25	27	15.00	15.14	15.03	1
10M	DFT-S 16QAM	1	1	15.69	15.88	15.74	1
10M	DFT-S 64QAM	1	1	14.14	14.44	14.19	2.5
10M	DFT-S 256QAM	1	1	12.26	12.41	12.26	4.5
10M	CP QPSK	1	1	15.22	15.39	15.21	1.5
BW	MCS Index	Channel		342500	349000	355500	3GPP MPR
		Frequency (MHz)		1712.5	1745	1777.5	
5M	DFT-S PI/2 BPSK	1	1	16.63	16.90	16.68	0
5M	DFT-S QPSK	1	1	16.71	16.93	16.68	0
		1	13	16.48	16.56	16.46	0
		1	23	16.84	16.92	16.84	0
		12	0	15.81	15.99	15.90	1
		12	7	16.24	16.25	16.23	0
		12	13	15.05	15.12	14.99	1
5M	DFT-S 16QAM	1	1	15.77	15.80	15.75	1
5M	DFT-S 64QAM	1	1	14.20	14.47	14.20	2.5
5M	DFT-S 256QAM	1	1	12.28	12.49	12.25	4.5
5M	CP QPSK	1	1	15.17	15.49	15.27	1.5

NR Conducted Power (Laptop)							
NR Band 71_SA							
BW	MCS Index	RB Size	RB Offset	Low	Mid	High	3GPP MPR (dB)
		Channel		134600	136100	137600	
		Frequency (MHz)		673	680.5	688	
20M	DFT-S PI/2 BPSK	1	1	19.81	19.91	19.83	0
20M	DFT-S QPSK	1	1	19.89	19.99	19.91	0
		1	53	19.10	19.13	19.11	0
		1	104	19.06	19.06	19.02	0
		50	0	18.05	18.15	18.11	1
		50	28	19.13	19.21	19.11	0
		50	56	18.25	18.31	18.25	1
100	0	18.16	18.18	18.12	1		
20M	DFT-S 16QAM	1	1	18.92	19.02	18.93	1
20M	DFT-S 64QAM	1	1	17.38	17.47	17.40	2.5
20M	DFT-S 256QAM	1	1	15.44	15.51	15.40	4.5
20M	CP QPSK	1	1	18.39	18.49	18.41	1.5
BW	MCS Index	Channel		134100	136100	138100	3GPP MPR
		Frequency (MHz)		670.5	680.5	690.5	
15M	DFT-S PI/2 BPSK	1	1	19.74	19.88	19.82	0
15M	DFT-S QPSK	1	1	19.79	19.96	19.89	0
		1	40	19.08	19.07	19.10	0
		1	77	19.05	19.04	19.01	0
		36	0	18.04	18.09	18.05	1
		36	22	19.04	19.19	19.04	0
		36	43	18.24	18.23	18.16	1
75	0	18.13	18.18	18.09	1		
15M	DFT-S 16QAM	1	1	18.85	19.01	18.93	1
15M	DFT-S 64QAM	1	1	17.29	17.37	17.31	2.5
15M	DFT-S 256QAM	1	1	15.37	15.51	15.37	4.5
15M	CP QPSK	1	1	18.35	18.46	18.39	1.5

NR Conducted Power (Laptop)							
NR Band 71_SA							
BW	MCS Index	Channel		133600	136100	138600	3GPP MPR
		Frequency (MHz)		668	680.5	693	
10M	DFT-S PI/2 BPSK	1	1	19.72	19.87	19.82	0
10M	DFT-S QPSK	1	1	19.84	19.93	19.89	0
		1	26	19.04	19.06	19.09	0
		1	50	19.05	18.99	18.99	0
		25	0	18.02	18.11	18.11	1
		25	14	19.08	19.12	19.11	0
		25	27	18.16	18.23	18.17	1
10M	DFT-S 16QAM	1	1	18.84	18.97	18.85	1
10M	DFT-S 64QAM	1	1	17.28	17.46	17.32	2.5
10M	DFT-S 256QAM	1	1	15.34	15.44	15.33	4.5
10M	CP QPSK	1	1	18.34	18.46	18.40	1.5
BW	MCS Index	Channel		133100	136100	139100	3GPP MPR
		Frequency (MHz)		665.5	680.5	695.5	
5M	DFT-S PI/2 BPSK	1	1	19.74	19.83	19.74	0
5M	DFT-S QPSK	1	1	19.82	19.96	19.85	0
		1	13	19.05	19.11	19.05	0
		1	23	18.97	18.97	18.95	0
		12	0	18.05	18.12	18.08	1
		12	7	19.11	19.12	19.09	0
		12	13	18.19	18.31	18.24	1
5M	DFT-S 16QAM	1	1	18.88	18.96	18.85	1
5M	DFT-S 64QAM	1	1	17.34	17.41	17.32	2.5
5M	DFT-S 256QAM	1	1	15.35	15.44	15.33	4.5
5M	CP QPSK	1	1	18.34	18.42	18.32	1.5



NR Conducted Power (Laptop)							
NR Band 38_SA							
BW	MCS Index	Channel		516000	519000	522000	3GPP MPR
		Frequency (MHz)		2580	2595	2610	
20M	DFT-S PI/2 BPSK	1	1	18.39	18.62	18.47	0
20M	DFT-S QPSK	1	1	18.74	18.79	18.71	0
		1	26	18.45	18.64	18.49	0
		1	49	18.36	18.55	18.40	0
		25	0	18.34	18.53	18.38	1
		25	13	18.42	18.61	18.46	0
		25	26	18.38	18.57	18.42	1
50	0	18.37	18.56	18.41	1		
20M	DFT-S 16QAM	1	1	17.47	17.68	17.53	1
20M	DFT-S 64QAM	1	1	15.95	16.14	16.00	2.5
20M	DFT-S 256QAM	1	1	13.97	14.18	13.98	4.5
20M	CP QPSK	1	1	16.95	17.14	17.01	1.5
BW	MCS Index	Channel		515500	519000	522500	3GPP MPR
		Frequency (MHz)		2577.5	2595	2612.5	
15M	DFT-S PI/2 BPSK	1	1	18.30	18.59	18.41	0
15M	DFT-S QPSK	1	1	18.41	18.57	18.49	0
		1	19	18.45	18.60	18.46	0
		1	36	18.34	18.50	18.34	0
		18	0	18.34	18.61	18.45	1
		18	10	18.33	18.58	18.36	0
		18	20	18.33	18.57	18.32	1
36	0	18.35	18.51	18.37	1		
15M	DFT-S 16QAM	1	1	17.42	17.60	17.49	1
15M	DFT-S 64QAM	1	1	15.87	16.13	15.94	2.5
15M	DFT-S 256QAM	1	1	13.91	14.18	13.94	4.5
15M	CP QPSK	1	1	16.92	17.07	16.95	1.5

NR Conducted Power (Laptop)							
NR Band 38_SA							
BW	MCS Index	Channel		515000	519000	523000	3GPP MPR
		Frequency (MHz)		2575	2595	2615	
10M	DFT-S PI/2 BPSK	1	1	18.34	18.53	18.47	0
10M	DFT-S QPSK	1	1	18.38	18.63	18.49	0
		1	11	18.45	18.62	18.49	0
		1	22	18.28	18.53	18.35	0
		12	0	18.39	18.57	18.48	1
		12	6	18.33	18.52	18.37	0
		12	12	18.30	18.49	18.38	1
		24	0	18.29	18.53	18.41	1
10M	DFT-S 16QAM	1	1	17.47	17.66	17.49	1
10M	DFT-S 64QAM	1	1	15.87	16.10	15.97	2.5
10M	DFT-S 256QAM	1	1	13.94	14.12	13.90	4.5
10M	CP QPSK	1	1	16.89	17.11	17.01	1.5

NR Conducted Power (Laptop)							
NR Band 40_SA							
BW	MCS Index	Channel		468000	470000	472000	3GPP MPR
		Frequency (MHz)		2340	2350	2360	
80M	DFT-S PI/2 BPSK	1	1	17.63	17.75	17.69	0
80M	DFT-S QPSK	1	1	17.74	17.77	17.71	0
		1	109	17.73	17.75	17.66	0
		1	215	17.67	17.67	17.63	0
		108	0	17.65	17.58	17.64	1
		108	55	17.62	17.66	17.59	0
		108	109	17.08	17.14	17.10	1
80M	DFT-S 16QAM	1	1	17.04	17.09	17.00	1
80M	DFT-S 64QAM	1	1	16.66	16.86	16.72	1
80M	DFT-S 256QAM	1	1	15.16	15.39	15.22	2.5
80M	CP QPSK	1	1	13.16	13.36	13.22	4.5
80M	CP QPSK	1	1	16.17	16.37	16.22	1.5
BW	MCS Index	Channel		466000	470000	474000	3GPP MPR
		Frequency (MHz)		2330	2350	2370	
60M	DFT-S PI/2 BPSK	1	1	17.26	17.48	17.37	0
60M	DFT-S QPSK	1	1	17.34	17.54	17.38	0
		1	81	17.71	17.65	17.56	0
		1	160	17.67	17.64	17.61	0
		81	0	17.56	17.50	17.49	1
		81	41	17.52	17.59	17.50	0
		81	81	17.04	17.04	17.03	1
60M	DFT-S 16QAM	162	0	17.01	17.04	16.91	1
60M	DFT-S 16QAM	1	1	16.66	16.84	16.71	1
60M	DFT-S 64QAM	1	1	15.12	15.34	15.19	2.5
60M	DFT-S 256QAM	1	1	13.09	13.32	13.20	4.5
60M	CP QPSK	1	1	16.11	16.36	16.16	1.5

NR Conducted Power (Laptop)							
NR Band 40_SA							
BW	MCS Index	Channel		465000	470000	475000	3GPP MPR
		Frequency (MHz)		2325	2350	2375	
50M	DFT-S PI/2 BPSK	1	1	17.63	17.74	17.61	0
50M	DFT-S QPSK	1	1	17.37	17.56	17.33	0
		1	67	17.68	17.69	17.57	0
		1	131	17.64	17.63	17.63	0
		64	0	17.46	17.55	17.47	1
		64	35	17.54	17.60	17.55	0
		64	69	17.00	17.10	17.09	1
50M	DFT-S 16QAM	1	1	16.62	16.85	16.64	1
50M	DFT-S 64QAM	1	1	15.08	15.35	15.22	2.5
50M	DFT-S 256QAM	1	1	13.07	13.30	13.21	4.5
50M	CP QPSK	1	1	16.17	16.27	16.13	1.5
BW	MCS Index	Channel		464000	470000	476000	3GPP MPR
		Frequency (MHz)		2320	2350	2380	
40M	DFT-S PI/2 BPSK	1	1	17.59	17.71	17.69	0
40M	DFT-S QPSK	1	1	17.33	17.56	17.37	0
		1	53	17.63	17.73	17.62	0
		1	104	17.65	17.65	17.54	0
		50	0	17.75	17.70	17.65	1
		50	28	17.56	17.58	17.50	0
		50	56	17.05	17.06	17.06	1
40M	DFT-S 16QAM	1	1	16.66	16.79	16.69	1
40M	DFT-S 64QAM	1	1	15.10	15.30	15.16	2.5
40M	DFT-S 256QAM	1	1	13.07	13.34	13.13	4.5
40M	CP QPSK	1	1	16.16	16.33	16.17	1.5

NR Conducted Power (Laptop)							
NR Band 40_SA							
BW	MCS Index	Channel		462000	470000	478000	3GPP MPR
		Frequency (MHz)		2310	2350	2390	
20M	DFT-S PI/2 BPSK	1	1	17.63	17.73	17.62	0
20M	DFT-S QPSK	1	1	17.32	17.56	17.41	0
		1	26	17.63	17.74	17.61	0
		1	49	17.66	17.58	17.55	0
		25	0	17.36	17.47	17.40	1
		25	13	17.61	17.63	17.49	0
		25	26	16.99	17.12	17.04	1
		50	0	16.95	17.07	17.00	1
20M	DFT-S 16QAM	1	1	16.58	16.84	16.69	1
20M	DFT-S 64QAM	1	1	15.11	15.32	15.22	2.5
20M	DFT-S 256QAM	1	1	13.07	13.26	13.16	4.5
20M	CP QPSK	1	1	16.07	16.37	16.12	1.5
BW	MCS Index	Channel		461500	470000	478500	3GPP MPR
		Frequency (MHz)		2307.5	2350	2392.5	
15M	DFT-S PI/2 BPSK	1	1	17.61	17.75	17.65	0
15M	DFT-S QPSK	1	1	17.58	17.53	17.64	0
		1	19	17.64	17.65	17.59	0
		1	36	17.67	17.67	17.58	0
		18	0	17.74	17.68	17.66	1
		18	10	17.54	17.56	17.50	0
		18	20	17.04	17.05	17.09	1
		36	0	16.98	17.05	16.96	1
15M	DFT-S 16QAM	1	1	16.56	16.83	16.66	1
15M	DFT-S 64QAM	1	1	15.14	15.37	15.12	2.5
15M	DFT-S 256QAM	1	1	13.15	13.34	13.18	4.5
15M	CP QPSK	1	1	16.07	16.33	16.21	1.5

NR Conducted Power (Laptop)							
NR Band 40_SA							
BW	MCS Index	Channel		461000	470000	479000	3GPP MPR
		Frequency (MHz)		2305	2350	2395	
10M	DFT-S PI/2 BPSK	1	1	17.62	17.74	17.69	0
10M	DFT-S QPSK	1	1	17.62	17.53	17.72	0
		1	11	17.65	17.74	17.59	0
		1	22	17.66	17.65	17.61	0
		12	0	17.68	17.68	17.67	1
		12	6	17.54	17.63	17.57	0
		12	12	17.05	17.06	17.10	1
		24	0	17.04	17.02	16.98	1
10M	DFT-S 16QAM	1	1	16.57	16.81	16.67	1
10M	DFT-S 64QAM	1	1	15.06	15.30	15.19	2.5
10M	DFT-S 256QAM	1	1	13.14	13.31	13.15	4.5
10M	CP QPSK	1	1	16.12	16.28	16.17	1.5

NR Conducted Power (Laptop)									
NR Band 41_SA									
BW	MCS Index	RB Size	RB Offset	Low	Mid-1	Mid-2	Mid-3	High	3GPP MPR (dB)
		Channel		509202	513900	518598	523302	528000	
		Frequency (MHz)		2546.01	2569.5	2592.99	2616.51	2640	
100M	DFT-S PI/2 BPSK	1	1	16.54	16.65	16.92	16.53	16.62	0
100M	DFT-S QPSK	1	1	16.71	16.68	16.99	16.65	16.73	0
		1	137	16.43	16.32	16.74	16.32	16.18	0
		1	271	16.39	16.28	16.70	16.28	16.14	0
		135	0	15.18	15.07	15.49	15.07	14.93	1
		135	69	16.20	16.09	16.51	16.09	15.95	0
		135	138	15.69	15.58	15.99	15.58	15.44	1
100M	DFT-S 16QAM	1	1	15.58	15.47	15.89	15.47	15.33	1
100M	DFT-S 64QAM	1	1	14.08	13.97	14.39	13.97	13.83	2.5
100M	DFT-S 256QAM	1	1	12.08	11.97	12.39	11.97	11.83	4.5
100M	CP QPSK	1	1	14.88	14.77	15.19	14.77	14.63	1.5
BW	MCS Index	Channel		508200	513402	518598	523800	528996	3GPP MPR
		Frequency (MHz)		2541	2567.01	2592.99	2619	2644.98	
90M	DFT-S PI/2 BPSK	1	1	16.42	16.36	16.89	16.30	16.43	0
90M	DFT-S QPSK	1	1	16.62	16.48	16.95	16.37	16.40	0
		1	123	16.68	16.68	16.76	16.76	16.80	0
		1	243	16.44	16.45	16.69	16.62	16.52	0
		120	0	15.32	15.33	15.39	15.48	15.40	1
		120	63	14.06	13.89	14.02	13.99	13.99	0
		120	125	15.54	15.46	15.72	15.58	15.59	1
90M	DFT-S 16QAM	1	1	15.61	15.53	15.97	15.42	15.33	1
90M	DFT-S 64QAM	1	1	14.04	14.02	14.49	13.90	13.89	2.5
90M	DFT-S 256QAM	1	1	12.11	11.96	12.40	11.96	11.90	4.5
90M	CP QPSK	1	1	15.06	15.04	15.47	14.97	14.92	1.5

NR Conducted Power (Laptop)									
NR Band 41_SA									
BW	MCS Index	Channel		507204	509304	518598	500298	529998	3GPP MPR
		Frequency (MHz)		2536.02	2546.52	2592.99	2621.49	2649.99	
80M	DFT-S PI/2 BPSK	1	1	16.42	16.41	16.84	16.28	16.44	0
80M	DFT-S QPSK	1	1	16.59	16.56	16.91	16.39	16.36	0
		1	109	16.61	16.73	16.80	16.74	16.81	0
		1	215	16.45	16.45	16.61	16.65	16.51	0
		108	0	15.36	15.28	15.42	15.45	15.36	1
		108	55	13.99	13.81	14.02	13.91	13.99	0
		108	109	15.57	15.50	15.67	15.60	15.57	1
80M	DFT-S 16QAM	1	1	15.55	15.53	15.97	15.38	15.34	1
80M	DFT-S 64QAM	1	1	14.10	14.07	14.46	13.89	13.92	2.5
80M	DFT-S 256QAM	1	1	12.03	11.95	12.48	11.88	11.92	4.5
80M	CP QPSK	1	1	15.10	14.97	15.48	14.96	14.94	1.5
BW	MCS Index	Channel		506202	512400	518598	524802	531000	3GPP MPR
		Frequency (MHz)		2531.01	2562	2592.99	2624.01	2655	
70M	DFT-S PI/2 BPSK	1	1	16.50	16.40	16.88	16.32	16.35	0
70M	DFT-S QPSK	1	1	16.61	16.54	16.94	16.43	16.41	0
		1	95	16.62	16.70	16.76	16.77	16.82	0
		1	187	16.38	16.46	16.65	16.59	16.58	0
		90	0	15.31	15.34	15.39	15.40	15.46	1
		90	50	13.99	13.87	13.99	13.90	13.93	0
		90	99	15.56	15.51	15.63	15.58	15.63	1
70M	DFT-S 16QAM	1	1	15.55	15.48	15.99	15.39	15.39	1
70M	DFT-S 64QAM	1	1	14.08	13.99	14.45	13.91	13.87	2.5
70M	DFT-S 256QAM	1	1	12.10	12.02	12.44	11.93	11.93	4.5
70M	CP QPSK	1	1	15.06	14.97	15.50	14.94	14.91	1.5



NR Conducted Power (Laptop)									
NR Band 41_SA									
BW	MCS Index	Channel		505200	511896	518598	525294	531996	3GPP MPR
		Frequency (MHz)		2526	2559.48	2592.99	2626.48	2659.98	
60M	DFT-S PI/2 BPSK	1	1	16.44	16.41	16.87	16.26	16.41	0
60M	DFT-S QPSK	1	1	16.55	16.55	16.92	16.37	16.35	0
		1	81	16.59	16.67	16.78	16.81	16.83	0
		1	160	16.39	16.43	16.66	16.61	16.57	0
		81	0	15.31	15.29	15.40	15.38	15.38	1
		81	41	14.00	13.87	14.00	13.96	13.92	0
		81	81	15.63	15.52	15.70	15.58	15.60	1
60M	DFT-S 16QAM	1	1	15.53	15.53	15.95	15.45	15.33	1
60M	DFT-S 64QAM	1	1	14.01	14.05	14.48	13.96	13.93	2.5
60M	DFT-S 256QAM	1	1	12.06	12.02	12.47	11.94	11.90	4.5
60M	CP QPSK	1	1	15.03	15.03	15.48	14.96	14.90	1.5
BW	MCS Index	Channel		504204	511404	518598	525798	532998	3GPP MPR
		Frequency (MHz)		2521.02	2557.02	2592.99	2628.99	2664.99	
50M	DFT-S PI/2 BPSK	1	1	16.44	16.41	16.88	16.31	16.44	0
50M	DFT-S QPSK	1	1	16.58	16.51	16.94	16.39	16.35	0
		1	67	16.66	16.65	16.82	16.73	16.76	0
		1	131	16.45	16.53	16.64	16.66	16.54	0
		64	0	15.35	15.31	15.4	15.44	15.37	1
		64	35	14.03	13.8	13.99	13.93	13.9	0
		64	69	15.62	15.53	15.65	15.66	15.54	1
50M	DFT-S 16QAM	1	1	15.54	15.54	15.95	15.37	15.4	1
50M	DFT-S 64QAM	1	1	14.02	13.97	14.47	13.9	13.91	2.5
50M	DFT-S 256QAM	1	1	12.08	12.01	12.44	11.96	11.88	4.5
50M	CP QPSK	1	1	15.09	15	15.48	14.88	14.92	1.5

NR Conducted Power (Laptop)									
NR Band 41_SA									
BW	MCS Index	Channel		503202	510900	518598	526296	534000	3GPP MPR
		Frequency (MHz)		2516.01	2554.5	2592.99	2631.48	2670	
40M	DFT-S PI/2 BPSK	1	1	16.43	16.43	16.82	16.33	16.44	0
40M	DFT-S QPSK	1	1	16.58	16.48	16.93	16.39	16.41	0
		1	53	16.64	16.63	16.79	16.81	16.77	0
		1	104	16.45	16.45	16.66	16.66	16.51	0
		50	0	15.35	15.33	15.42	15.47	15.45	1
		50	28	14.01	13.86	13.98	13.89	13.97	0
		50	56	15.58	15.51	15.72	15.64	15.63	1
40M	DFT-S 16QAM	1	1	15.54	15.45	15.96	15.46	15.40	1
40M	DFT-S 64QAM	1	1	14.04	14.05	14.47	13.86	13.95	2.5
40M	DFT-S 256QAM	1	1	12.09	12.02	12.49	11.88	11.89	4.5
40M	CP QPSK	1	1	15.04	15.03	15.48	14.91	14.85	1.5
BW	MCS Index	Channel		502200	510396	518598	526794	534996	3GPP MPR
		Frequency (MHz)		2511	2551.98	2592.99	2633.97	2674.98	
30M	DFT-S PI/2 BPSK								
30M	DFT-S QPSK								
30M	DFT-S 16QAM								
30M	DFT-S 64QAM								
30M	DFT-S 256QAM								
30M	CP QPSK								

NR Conducted Power (Laptop)									
NR Band 41_SA									
BW	MCS Index	Channel		501204	509898	518598	527298	535998	3GPP MPR
		Frequency (MHz)		2506.02	2549.49	2592.99	2636.49	2679.99	
20M	DFT-S PI/2 BPSK	1	1	16.49	16.61	16.89	16.49	16.64	0
20M	DFT-S QPSK	1	1	16.64	16.61	16.97	16.61	16.64	0
		1	26	16.41	16.25	16.71	16.36	16.32	0
		1	49	16.32	16.21	16.65	16.35	16.18	0
		25	0	15.14	15.05	15.43	15.09	15.05	1
		25	13	16.11	16.02	16.45	16.10	16.09	0
		25	26	15.59	15.51	15.89	15.59	15.58	1
50	0	15.62	15.56	15.89	15.67	15.53	1		
20M	DFT-S 16QAM	1	1	15.48	15.42	15.89	15.54	15.37	1
20M	DFT-S 64QAM	1	1	14.08	13.96	14.38	14.05	13.89	2.5
20M	DFT-S 256QAM	1	1	12.01	11.97	12.32	11.99	11.91	4.5
20M	CP QPSK	1	1	14.78	14.71	15.16	14.82	14.77	1.5
BW	MCS Index	Channel		500700	509646	518598	527544	536496	3GPP MPR
		Frequency (MHz)		2503.5	2548.23	2592.99	2637.72	2682.48	
15M	DFT-S PI/2 BPSK	1	1	16.52	16.62	16.91	16.45	16.56	0
15M	DFT-S QPSK	1	1	16.65	16.65	16.93	16.67	16.60	0
		1	19	16.39	16.27	16.64	16.34	16.28	0
		1	36	16.31	16.24	16.62	16.30	16.18	0
		18	0	15.16	15.02	15.46	15.17	15.02	1
		18	10	16.19	16.04	16.47	16.15	16.00	0
		18	20	15.66	15.57	15.89	15.64	15.58	1
36	0	15.65	15.57	15.96	15.61	15.54	1		
15M	DFT-S 16QAM	1	1	15.58	15.47	15.81	15.50	15.43	1
15M	DFT-S 64QAM	1	1	14.00	13.90	14.32	14.05	13.91	2.5
15M	DFT-S 256QAM	1	1	12.00	11.96	12.31	12.03	11.91	4.5
15M	CP QPSK	1	1	14.84	14.75	15.16	14.82	14.77	1.5

NR Conducted Power (Laptop)									
NR Band 41_SA									
BW	MCS Index	Channel		500202	509400	518598	527796	537000	3GPP MPR
		Frequency (MHz)		2501.01	2547	2592.99	2638.98	2685	
10M	DFT-S PI/2 BPSK	1	1	16.54	16.56	16.89	16.45	16.57	0
10M	DFT-S QPSK	1	1	16.67	16.65	16.95	16.70	16.58	0
		1	11	16.37	16.25	16.74	16.37	16.22	0
		1	22	16.33	16.24	16.60	16.38	16.19	0
		12	0	15.17	15.07	15.48	15.10	15.01	1
		12	6	16.13	16.08	16.44	16.16	16.01	0
		12	12	15.68	15.52	15.91	15.59	15.52	1
		24	0	15.59	15.50	15.93	15.65	15.54	1
10M	DFT-S 16QAM	1	1	15.53	15.43	15.79	15.48	15.39	1
10M	DFT-S 64QAM	1	1	13.99	13.93	14.37	14.08	13.90	2.5
10M	DFT-S 256QAM	1	1	12.01	11.94	12.33	12.03	11.88	4.5
10M	CP QPSK	1	1	14.87	14.77	15.11	14.86	14.71	1.5

NR Conducted Power (Laptop)								
NR Band 48_SA								
BW	MCS Index	Channel		638000	640444	642888	645332	3GPP MPR
		Frequency (MHz)		3570	3606.66	3643.32	3679.98	
40M	DFT-S PI/2 BPSK	1	1	14.49	14.32	14.50	14.41	0
40M	DFT-S QPSK	1	1	14.64	14.51	14.64	14.54	0
		1	53	14.51	14.29	14.34	14.42	0
		1	104	14.32	14.14	14.23	14.23	0
		50	0	13.72	13.53	13.67	13.69	1
		50	28	14.66	14.48	14.59	14.54	0
		50	56	13.96	13.80	13.86	13.79	1
100	0	13.67	13.57	13.62	13.66	1		
40M	DFT-S 16QAM	1	1	13.55	13.39	13.49	13.52	1
40M	DFT-S 64QAM	1	1	12.13	11.93	12.04	12.02	2.5
40M	DFT-S 256QAM	1	1	10.10	9.96	10.06	9.97	4.5
40M	CP QPSK	1	1	13.14	12.90	13.00	12.94	1.5
BW	MCS Index	Channel		637334	640222	643110	646000	3GPP MPR
		Frequency (MHz)		3560.01	3603.33	3646.65	3690	
20M	DFT-S PI/2 BPSK	1	1	14.45	14.36	14.51	14.46	0
20M	DFT-S QPSK	1	1	14.63	14.48	14.56	14.59	0
		1	26	14.52	14.28	14.36	14.36	0
		1	49	14.33	14.08	14.18	14.23	0
		25	0	13.70	13.56	13.64	13.69	1
		25	13	14.64	14.46	14.49	14.52	0
		25	26	13.87	13.75	13.83	13.87	1
50	0	13.74	13.53	13.68	13.60	1		
20M	DFT-S 16QAM	1	1	13.58	13.47	13.56	13.54	1
20M	DFT-S 64QAM	1	1	12.13	11.91	12.05	11.99	2.5
20M	DFT-S 256QAM	1	1	10.08	9.87	9.99	10.03	4.5
20M	CP QPSK	1	1	13.12	12.88	13.00	12.95	1.5

NR Conducted Power (Laptop)								
NR Band 48_SA								
BW	MCS Index	Channel		637168	640168	643166	646166	3GPP MPR
		Frequency (MHz)		3557.52	3602.52	3647.49	3692.49	
15M	DFT-S PI/2 BPSK	1	1	14.52	14.40	14.41	14.39	0
15M	DFT-S QPSK	1	1	14.72	14.57	14.65	14.59	0
		1	19	14.51	14.30	14.41	14.40	0
		1	36	14.32	14.14	14.19	14.14	0
		18	0	13.69	13.54	13.66	13.63	1
		18	10	14.62	14.50	14.57	14.54	0
		18	20	13.90	13.78	13.86	13.79	1
		36	0	13.74	13.54	13.65	13.64	1
15M	DFT-S 16QAM	1	1	13.62	13.41	13.54	13.52	1
15M	DFT-S 64QAM	1	1	12.06	11.95	12.05	12.02	2.5
15M	DFT-S 256QAM	1	1	10.07	9.94	10.06	9.95	4.5
15M	CP QPSK	1	1	13.05	12.96	12.98	12.99	1.5
BW	MCS Index	Channel		637000	640110	643222	646332	3GPP MPR
		Frequency (MHz)		3555	3601.65	3648.33	3694.98	
10M	DFT-S PI/2 BPSK	1	1	14.44	14.33	14.44	14.45	0
10M	DFT-S QPSK	1	1	14.65	14.51	14.66	14.56	0
		1	11	14.47	14.35	14.36	14.35	0
		1	22	14.27	14.08	14.24	14.15	0
		12	0	13.76	13.55	13.60	13.66	1
		12	6	14.65	14.49	14.52	14.52	0
		12	12	13.91	13.76	13.88	13.85	1
		24	0	13.75	13.57	13.64	13.60	1
10M	DFT-S 16QAM	1	1	13.62	13.41	13.52	13.49	1
10M	DFT-S 64QAM	1	1	12.06	11.92	12.04	11.96	2.5
10M	DFT-S 256QAM	1	1	10.03	9.92	9.97	10.03	4.5
10M	CP QPSK	1	1	13.14	12.93	13.02	13.03	1.5

NR Conducted Power (Laptop)									
NR Band 77_SA									
BW	MCS Index	RB Size	RB Offset	Low	Mid-1	Mid-2	Mid-3	High	3GPP MPR (dB)
		Channel		650000	653000	656000	659000	662000	
		Frequency (MHz)		3750	3795	3840	3885	3930	
100M	DFT-S PI/2 BPSK	1	1	20.39	20.34	20.13	19.83	19.60	0
100M	DFT-S QPSK	1	1	20.47	20.49	20.36	20.41	19.93	0
		1	137	20.04	19.99	19.79	19.50	19.28	0
		1	271	19.16	19.11	18.91	18.62	18.40	0
		135	0	19.10	19.05	18.85	18.56	18.34	1
		135	69	20.10	20.17	19.90	19.61	19.39	0
		135	138	18.97	18.92	18.72	18.43	18.21	1
		270	0	18.94	18.89	18.69	18.40	18.18	1
100M	DFT-S 16QAM	1	1	17.90	17.85	17.65	17.36	17.14	1
100M	DFT-S 64QAM	1	1	16.90	16.85	16.65	16.36	16.14	2.5
100M	DFT-S 256QAM	1	1	14.70	14.65	14.45	14.16	13.94	4.5
100M	CP QPSK	1	1	19.01	18.96	18.76	18.47	18.25	1.5
BW	MCS Index	Channel		649668	652834	656000	659166	662332	3GPP MPR
		Frequency (MHz)		3745.02	3792.51	3840	3887.49	3934.98	
90M	DFT-S PI/2 BPSK	1	1	20.33	20.31	20.32	20.26	20.13	0
90M	DFT-S QPSK	1	1	20.42	20.43	20.40	20.43	20.36	0
		1	123	20.03	19.95	19.99	19.98	19.71	0
		1	243	19.15	19.09	19.12	19.04	18.91	0
		120	0	19.08	18.99	19.02	18.96	18.76	1
		120	63	20.05	20.05	20.09	20.09	19.80	0
		120	125	18.95	18.92	18.96	18.86	18.65	1
		243	0	18.91	18.86	18.87	18.80	18.68	1
90M	DFT-S 16QAM	1	1	17.88	17.83	17.89	17.85	17.65	1
90M	DFT-S 64QAM	1	1	16.85	16.80	16.85	16.82	16.65	2.5
90M	DFT-S 256QAM	1	1	14.64	14.56	14.69	14.60	14.36	4.5
90M	CP QPSK	1	1	18.93	18.88	18.99	18.93	18.69	1.5

NR Conducted Power (Laptop)									
NR Band 77_SA									
BW	MCS Index	Channel		649334	652666	656000	659334	662666	3GPP MPR
		Frequency (MHz)		3740.01	3789.99	3840	3890.01	3939.99	
80M	DFT-S PI/2 BPSK	1	1	20.37	20.26	20.08	20.25	20.12	0
80M	DFT-S QPSK	1	1	20.48	20.47	20.36	20.35	20.15	0
		1	109	20.03	19.99	19.71	19.95	19.73	0
		1	215	19.08	19.02	18.91	19.11	18.84	0
		108	0	19.10	18.99	18.76	18.95	18.84	1
		108	55	20.15	20.07	19.85	20.04	19.87	0
		108	109	18.92	18.88	18.71	18.85	18.67	1
80M	DFT-S 16QAM	1	1	17.87	17.80	17.65	17.76	17.62	1
80M	DFT-S 64QAM	1	1	16.87	16.77	16.57	16.80	16.57	2.5
80M	DFT-S 256QAM	1	1	14.64	14.59	14.35	14.62	14.38	4.5
80M	CP QPSK	1	1	18.92	18.88	18.69	18.93	18.68	1.5
BW	MCS Index	Channel		649000	652500	656000	659500	663000	3GPP MPR
		Frequency (MHz)		3735	3787.5	3840	3892.5	3945	
70M	DFT-S PI/2 BPSK	1	1	20.33	20.39	20.27	20.04	20.12	0
70M	DFT-S QPSK	1	1	20.42	20.45	20.38	20.34	20.15	0
		1	95	20.03	19.96	19.97	19.74	19.73	0
		1	187	19.15	19.09	19.07	18.88	18.84	0
		90	0	19.08	19.08	18.97	18.80	18.84	1
		90	50	20.05	20.14	20.00	19.80	19.87	0
		90	99	18.95	18.94	18.87	18.67	18.67	1
70M	DFT-S 16QAM	1	1	17.88	17.81	17.78	17.62	17.62	1
70M	DFT-S 64QAM	1	1	16.85	16.88	16.77	16.55	16.57	2.5
70M	DFT-S 256QAM	1	1	14.64	14.61	14.63	14.35	14.38	4.5
70M	CP QPSK	1	1	18.93	18.92	18.92	18.69	18.68	1.5



NR Conducted Power (Laptop)									
NR Band 77_SA									
BW	MCS Index	Channel		648668	652334	656000	659666	663332	3GPP MPR
		Frequency (MHz)		3730.02	3785.01	3840	3894.99	3949.98	
60M	DFT-S PI/2 BPSK	1	1	20.35	20.26	20.04	20.25	20.12	0
60M	DFT-S QPSK	1	1	20.46	20.38	20.31	20.35	20.15	0
		1	81	19.97	19.93	19.79	19.95	19.73	0
		1	160	19.07	19.10	18.86	19.11	18.84	0
		81	0	19.10	19.01	18.77	18.95	18.84	1
		81	41	20.14	20.09	19.84	20.04	19.87	0
		81	81	18.88	18.91	18.63	18.85	18.67	1
60M	DFT-S 16QAM	1	1	17.84	17.77	17.61	17.76	17.62	1
60M	DFT-S 64QAM	1	1	16.84	16.83	16.55	16.80	16.57	2.5
60M	DFT-S 256QAM	1	1	14.62	14.63	14.40	14.62	14.38	4.5
60M	CP QPSK	1	1	18.96	18.95	18.68	18.93	18.68	1.5
BW	MCS Index	Channel		648334	652166	656000	659834	663666	3GPP MPR
		Frequency (MHz)		3725.01	3782.49	3840	3897.51	3954.99	
50M	DFT-S PI/2 BPSK	1	1	20.33	20.31	20.37	20.28	20.08	0
50M	DFT-S QPSK	1	1	20.42	20.43	20.44	20.45	20.36	0
		1	67	20.03	19.95	20.03	19.95	19.70	0
		1	131	19.15	19.09	19.08	19.06	18.90	0
		64	0	19.08	18.99	19.07	18.97	18.77	1
		64	35	20.05	20.05	20.12	20.04	19.81	0
		64	69	18.95	18.92	18.92	18.83	18.68	1
50M	DFT-S 16QAM	1	1	17.88	17.83	17.87	17.76	17.61	1
50M	DFT-S 64QAM	1	1	16.85	16.80	16.83	16.84	16.64	2.5
50M	DFT-S 256QAM	1	1	14.64	14.56	14.65	14.65	14.38	4.5
50M	CP QPSK	1	1	18.93	18.88	19.00	18.96	18.72	1.5

NR Conducted Power (Laptop)									
NR Band 77_SA									
BW	MCS Index	Channel		648000	652000	656000	660000	664000	3GPP MPR
		Frequency (MHz)		3720	3780	3840	3900	3960	
40M	DFT-S PI/2 BPSK	1	1	20.33	20.34	20.33	20.12	20.12	0
40M	DFT-S QPSK	1	1	20.42	20.41	20.46	20.33	20.15	0
		1	53	20.03	20.01	19.91	19.71	19.73	0
		1	104	19.15	19.14	19.02	18.81	18.84	0
		50	0	19.08	19.04	18.99	18.83	18.84	1
		50	28	20.05	20.07	20.04	19.82	19.87	0
		50	56	18.95	18.96	18.84	18.71	18.67	1
100	0	18.91	18.84	18.85	18.68	18.67	1		
40M	DFT-S 16QAM	1	1	17.88	17.88	17.84	17.61	17.62	1
40M	DFT-S 64QAM	1	1	16.85	16.84	16.85	16.63	16.57	2.5
40M	DFT-S 256QAM	1	1	14.64	14.69	14.56	14.42	14.38	4.5
40M	CP QPSK	1	1	18.93	18.91	18.88	18.76	18.68	1.5
BW	MCS Index	Channel		647668	651834	656000	660166	664332	3GPP MPR
		Frequency (MHz)		3715.02	3777.51	3840	3902.49	3964.98	
30M	DFT-S PI/2 BPSK	1	1	20.37	20.28	20.04	20.25	20.12	0
30M	DFT-S QPSK	1	1	20.42	20.45	20.28	20.35	20.15	0
		1	39	19.96	19.92	19.76	19.95	19.73	0
		1	76	19.08	19.09	18.82	19.11	18.84	0
		36	0	19.05	19.00	18.83	18.95	18.84	1
		36	21	20.15	20.10	19.83	20.04	19.87	0
		36	42	18.91	18.84	18.64	18.85	18.67	1
75	0	18.89	18.87	18.63	18.79	18.67	1		
30M	DFT-S 16QAM	1	1	17.88	17.78	17.62	17.76	17.62	1
30M	DFT-S 64QAM	1	1	16.81	16.77	16.59	16.80	16.57	2.5
30M	DFT-S 256QAM	1	1	14.69	14.55	14.37	14.62	14.38	4.5
30M	CP QPSK	1	1	18.96	18.96	18.66	18.93	18.68	1.5

NR Conducted Power (Laptop)									
NR Band 77_SA									
BW	MCS Index	Channel		647500	651750	656000	660250	664500	3GPP MPR
		Frequency (MHz)		3712.5	3776.25	3840	3903.75	3967.5	
25M	DFT-S PI/2 BPSK								
25M	DFT-S QPSK								
25M	DFT-S 16QAM								
25M	DFT-S 64QAM								
25M	DFT-S 256QAM								
25M	CP QPSK								
25M									
BW	MCS Index	Channel		647334	651666	656000	660266	664666	3GPP MPR
		Frequency (MHz)		3710.01	3774.99	3840	3903.99	3969.99	
20M	DFT-S PI/2 BPSK	1	1	20.33	20.31	20.30	20.30	20.11	0
20M	DFT-S QPSK	1	1	20.42	20.43	20.46	20.37	20.28	0
		1	26	20.03	19.95	20.01	19.92	19.77	0
		1	49	19.15	19.09	19.10	19.03	18.85	0
		25	0	19.08	18.99	19.10	18.98	18.83	1
		25	13	20.05	20.05	20.16	20.06	19.90	0
		25	26	18.95	18.92	18.89	18.83	18.72	1
20M	DFT-S 16QAM	50	0	18.91	18.86	18.93	18.87	18.61	1
20M	DFT-S 16QAM	1	1	17.88	17.83	17.83	17.81	17.64	1
20M	DFT-S 64QAM	1	1	16.85	16.80	16.88	16.76	16.58	2.5
20M	DFT-S 256QAM	1	1	14.64	14.56	14.65	14.64	14.41	4.5
20M	CP QPSK	1	1	18.93	18.88	19.01	18.94	18.66	1.5

NR Conducted Power (Laptop)									
NR Band 77_SA									
BW	MCS Index	Channel		647168	651584	656000	660416	664832	3GPP MPR
		Frequency (MHz)		3707.52	3773.76	3840	3906.24	3972.48	
15M	DFT-S PI/2 BPSK	1	1	20.33	20.32	20.25	20.07	20.12	0
15M	DFT-S QPSK	1	1	20.42	20.42	20.44	20.32	20.15	0
		1	19	20.03	20.00	19.99	19.79	19.73	0
		1	36	19.15	19.12	19.05	18.88	18.84	0
		18	0	19.08	19.10	18.97	18.79	18.84	1
		18	10	20.05	20.15	20.05	19.85	19.87	0
		18	20	18.95	18.89	18.89	18.66	18.67	1
36	0	18.91	18.87	18.86	18.66	18.67	1		
15M	DFT-S 16QAM	1	1	17.88	17.85	17.77	17.61	17.62	1
15M	DFT-S 64QAM	1	1	16.85	16.82	16.75	16.56	16.57	2.5
15M	DFT-S 256QAM	1	1	14.64	14.65	14.60	14.40	14.38	4.5
15M	CP QPSK	1	1	18.93	18.93	18.96	18.68	18.68	1.5
BW	MCS Index	Channel		647000	651500	656000	660500	665000	3GPP MPR
		Frequency (MHz)		3705	3772.5	3840	3907.5	3975	
10M	DFT-S PI/2 BPSK	1	1	20.33	20.27	20.13	20.25	20.12	0
10M	DFT-S QPSK	1	1	20.42	20.43	20.34	20.35	20.15	0
		1	11	20.00	19.91	19.78	19.95	19.73	0
		1	22	19.06	19.03	18.81	19.11	18.84	0
		12	0	19.06	18.97	18.77	18.95	18.84	1
		12	6	20.08	20.07	19.85	20.04	19.87	0
		12	12	18.89	18.91	18.71	18.85	18.67	1
24	0	18.94	18.85	18.59	18.79	18.67	1		
10M	DFT-S 16QAM	1	1	17.80	17.83	17.59	17.76	17.62	1
10M	DFT-S 64QAM	1	1	16.88	16.77	16.55	16.80	16.57	2.5
10M	DFT-S 256QAM	1	1	14.69	14.65	14.37	14.62	14.38	4.5
10M	CP QPSK	1	1	18.96	18.95	18.68	18.93	18.68	1.5

NR Conducted Power (Laptop)							
NR Band 78_SA							
BW	MCS Index	RB Size	RB Offset	Low	Mid	High	3GPP MPR (dB)
		Channel			650000		
		Frequency (MHz)			3750		
100M	DFT-S PI/2 BPSK	1	1		20.88		0
100M	DFT-S QPSK	1	1		20.98		0
		1	137		20.58		0
		1	271		20.61		0
		135	0		19.51		1
		135	69		20.78		0
		135	138		19.68		1
		270	0		19.70		1
100M	DFT-S 16QAM	1	1		19.89		1
100M	DFT-S 64QAM	1	1		18.42		2.5
100M	DFT-S 256QAM	1	1		16.39		4.5
100M	CP QPSK	1	1		19.40		1.5
BW	MCS Index	Channel		649668	650000	650332	3GPP MPR
		Frequency (MHz)		3745.02	3750	3754.98	
90M	DFT-S PI/2 BPSK	1	1	20.74	20.84	20.81	0
90M	DFT-S QPSK	1	1	20.79	20.89	20.84	0
		1	123	20.40	20.48	20.45	0
		1	243	20.53	20.58	20.57	0
		120	0	19.43	19.43	19.34	1
		120	63	20.63	20.68	20.62	0
		120	125	19.61	19.62	19.54	1
		243	0	19.59	19.67	19.62	1
90M	DFT-S 16QAM	1	1	19.78	19.88	19.82	1
90M	DFT-S 64QAM	1	1	18.27	18.38	18.32	2.5
90M	DFT-S 256QAM	1	1	16.30	16.38	16.32	4.5
90M	CP QPSK	1	1	19.28	19.38	19.32	1.5

NR Conducted Power (Laptop)							
NR Band 78_SA							
BW	MCS Index	Channel		649334	650000	650666	3GPP MPR
		Frequency (MHz)		3740.01	3750	3759.99	
80M	DFT-S PI/2 BPSK	1	1	20.72	20.76	20.78	0
80M	DFT-S QPSK	1	1	20.74	20.80	20.77	0
		1	109	20.32	20.43	20.35	0
		1	215	20.52	20.55	20.57	0
		108	0	19.36	19.40	19.29	1
		108	55	20.60	20.59	20.62	0
		108	109	19.51	19.58	19.45	1
80M	DFT-S 16QAM	1	1	19.76	19.78	19.78	1
80M	DFT-S 64QAM	1	1	18.17	18.36	18.27	2.5
80M	DFT-S 256QAM	1	1	16.22	16.37	16.23	4.5
80M	CP QPSK	1	1	19.22	19.33	19.24	1.5
BW	MCS Index	Channel		649000	650000	651000	3GPP MPR
		Frequency (MHz)		3735	3750	3765	
70M	DFT-S PI/2 BPSK	1	1	20.71	20.54	20.73	0
70M	DFT-S QPSK	1	1	20.78	20.61	20.75	0
		1	95	20.40	20.27	20.39	0
		1	187	20.52	19.41	20.52	0
		90	0	19.33	18.35	19.33	1
		90	50	20.57	20.43	20.53	0
		90	99	19.51	18.28	19.51	1
70M	DFT-S 16QAM	1	1	19.77	19.52	19.76	1
70M	DFT-S 64QAM	1	1	18.26	18.24	18.24	2.5
70M	DFT-S 256QAM	1	1	16.23	16.30	16.32	4.5
70M	CP QPSK	1	1	19.25	19.37	19.24	1.5

NR Conducted Power (Laptop)							
NR Band 78_SA							
BW	MCS Index	Channel		648668	650000	651332	3GPP MPR
		Frequency (MHz)		3730.02	3750	3769.98	
60M	DFT-S PI/2 BPSK	1	1	20.73	20.74	20.77	0
60M	DFT-S QPSK	1	1	20.74	20.89	20.81	0
		1	81	20.33	20.38	20.37	0
		1	160	20.51	20.56	20.54	0
		81	0	19.33	19.40	19.27	1
		81	41	20.56	20.60	20.54	0
		81	81	19.55	19.56	19.51	1
60M	DFT-S 16QAM	1	1	19.73	19.80	19.75	1
60M	DFT-S 64QAM	1	1	18.24	18.33	18.25	2.5
60M	DFT-S 256QAM	1	1	16.30	16.31	16.30	4.5
60M	CP QPSK	1	1	19.23	19.34	19.32	1.5
BW	MCS Index	Channel		648334	650000	651666	3GPP MPR
		Frequency (MHz)		3725.01	3750	3774.99	
50M	DFT-S PI/2 BPSK	1	1	20.74	20.79	20.80	0
50M	DFT-S QPSK	1	1	20.79	20.86	20.79	0
		1	67	20.34	20.41	20.37	0
		1	131	20.44	20.52	20.50	0
		64	0	19.39	19.39	19.29	1
		64	35	20.54	20.64	20.55	0
		64	69	19.59	19.62	19.48	1
50M	DFT-S 16QAM	1	1	19.74	19.88	19.80	1
50M	DFT-S 64QAM	1	1	18.27	18.33	18.26	2.5
50M	DFT-S 256QAM	1	1	16.20	16.36	16.32	4.5
50M	CP QPSK	1	1	19.18	19.33	19.23	1.5

NR Conducted Power (Laptop)							
NR Band 78_SA							
BW	MCS Index	Channel		648000	650000	652000	3GPP MPR
		Frequency (MHz)		3720	3750	3780	
40M	DFT-S PI/2 BPSK	1	1	20.67	20.82	20.77	0
40M	DFT-S QPSK	1	1	20.79	20.84	20.80	0
		1	53	20.40	20.41	20.38	0
		1	104	20.46	20.52	20.48	0
		50	0	19.38	19.36	19.31	1
		50	28	20.54	20.65	20.57	0
		50	56	19.59	19.54	19.47	1
40M	DFT-S 16QAM	1	1	19.69	19.80	19.73	1
40M	DFT-S 64QAM	1	1	18.19	18.32	18.25	2.5
40M	DFT-S 256QAM	1	1	16.30	16.31	16.27	4.5
40M	CP QPSK	1	1	19.19	19.32	19.27	1.5
BW	MCS Index	Channel		647668	650000	652332	3GPP MPR
		Frequency (MHz)		3715.02	3750	3784.98	
30M	DFT-S PI/2 BPSK	1	1	20.66	20.80	20.80	0
30M	DFT-S QPSK	1	1	20.72	20.84	20.83	0
		1	39	20.39	20.38	20.38	0
		1	76	20.45	20.50	20.48	0
		36	0	19.40	19.43	19.29	1
		36	21	20.58	20.61	20.52	0
		36	42	19.61	19.55	19.51	1
30M	DFT-S 16QAM	1	1	19.74	19.82	19.76	1
30M	DFT-S 64QAM	1	1	18.17	18.29	18.27	2.5
30M	DFT-S 256QAM	1	1	16.21	16.31	16.25	4.5
30M	CP QPSK	1	1	19.24	19.32	19.28	1.5



NR Conducted Power (Laptop)								
NR Band 78_SA								
BW	MCS Index	Channel		647500	650000	652500	3GPP MPR	
		Frequency (MHz)		3712.5	3750	3787.5		
25M	DFT-S PI/2 BPSK							
25M	DFT-S QPSK							
25M	DFT-S 16QAM							
25M	DFT-S 64QAM							
25M	DFT-S 256QAM							
25M	CP QPSK							
25M								
BW	MCS Index	Channel		647334	650000	652666	3GPP MPR	
		Frequency (MHz)		3710.01	3750	3789.99		
20M	DFT-S PI/2 BPSK	1	1	20.68	20.83	20.80	0	
20M	DFT-S QPSK	1	1	20.73	20.79	20.84	0	
		1	26	20.40	20.47	20.36	0	
		1	49	20.51	20.53	20.47	0	
		25	0	19.34	19.41	19.32	1	
		25	13	20.63	20.64	20.59	0	
		25	26	19.61	19.61	19.52	1	
20M	DFT-S 16QAM	1	1	19.68	19.85	19.72	1	
20M	DFT-S 64QAM	1	1	18.19	18.32	18.24	2.5	
20M	DFT-S 256QAM	1	1	16.25	16.34	16.25	4.5	
20M	CP QPSK	1	1	19.23	19.30	19.27	1.5	

NR Conducted Power (Laptop)							
NR Band 78_SA							
BW	MCS Index	Channel		647168	650000	652832	3GPP MPR
		Frequency (MHz)		3707.52	3750	3792.48	
15M	DFT-S PI/2 BPSK	1	1	20.72	20.74	20.72	0
15M	DFT-S QPSK	1	1	20.76	20.87	20.81	0
		1	19	20.34	20.48	20.37	0
		1	36	20.44	20.57	20.48	0
		18	0	19.42	19.39	19.27	1
		18	10	20.57	20.65	20.61	0
		18	20	19.61	19.62	19.48	1
		36	0	19.55	19.60	19.57	1
15M	DFT-S 16QAM	1	1	19.68	19.82	19.82	1
15M	DFT-S 64QAM	1	1	18.18	18.28	18.22	2.5
15M	DFT-S 256QAM	1	1	16.29	16.34	16.29	4.5
15M	CP QPSK	1	1	19.18	19.37	19.30	1.5
BW	MCS Index	Channel		647000	650000	653000	3GPP MPR
		Frequency (MHz)		3705	3750	3795	
10M	DFT-S PI/2 BPSK	1	1	20.64	20.77	20.76	0
10M	DFT-S QPSK	1	1	20.76	20.86	20.74	0
		1	11	20.38	20.45	20.44	0
		1	22	20.51	20.48	20.57	0
		12	0	19.35	19.41	19.32	1
		12	6	20.57	20.65	20.56	0
		12	12	19.55	19.54	19.54	1
		24	0	19.57	19.60	19.57	1
10M	DFT-S 16QAM	1	1	19.77	19.82	19.78	1
10M	DFT-S 64QAM	1	1	18.18	18.37	18.30	2.5
10M	DFT-S 256QAM	1	1	16.26	16.35	16.31	4.5
10M	CP QPSK	1	1	19.24	19.34	19.27	1.5

### Downlink Carrier Aggregation Exclusion Table

Intra Band					Inter Band										
Contiguous	3CC		4CC	5CC	2 Bands / 2CC	2 Bands / 3CC	2 Bands / 4CC	2 Bands / 5CC	3 Bands / 3CC	3 Bands / 4CC	3 Bands / 5CC	4 Bands / 4CC	4 Bands / 5CC		
	Contiguous	Non-Contiguous												Non-Contiguous	
CA 2A-2A					CA 2A-12A	CA 2A-2A-12A			CA 2A-12A-30A	CA 2A-2A-12A-30A		CA 2A-12A-30A-66A	CA_2A-2A-12A-30A-66A		
					CA 2A-30A	CA 2A-2A-30A			CA 2A-12A-66A	CA 2A-2A-12A-66A					
					CA 2A-66A	CA 2A-2A-66A			CA 2A-30A-66A	CA 2A-2A-30A-66A					
					CA 12A-30A				CA 12A-30A-66A						
					CA 12A-66A										
					CA 30A-66A										
					CA 2A-14A	CA 2A-2A-14A			CA 2A-14A-30A	CA 2A-2A-14A-30A				CA 2A-14A-30A-66A	
					CA 14A-30A				CA 2A-14A-66A						
					CA 14A-66A				CA 2A-14A-66A						
					CA 14A-66A				CA 14A-30A-66A						
CA 48A-48A					CA 2A-5A	CA 2A-48A-48A			CA 2A-5A-48A	CA 2A-5A-48A-48A		CA 2A-5A-48A-66A	CA_2A-5A-48A-66A		
					CA 2A-48A	CA 5A-48A-48A			CA 2A-5A-66A	CA 2A-48A-48A-66A					
					CA 5A-48A	CA 48A-48A-66A			CA 2A-48A-66A	CA 5A-48A-48A-66A					
					CA 5A-66A				CA 2A-48A-66A						
					CA 48A-66A				CA 5A-48A-66A						
CA 5B						CA 2A-5B				CA 2A-5B-30A			CA_2A-5B-30A-66A		
						CA 5B-30A				CA 2A-5B-66A					
						CA 5B-66A				CA 5B-30A-66A					
						CA 2A-66A-66A				CA 2A-12A-66A-66A					
						CA 12A-66A-66A				CA 2A-30A-66A-66A					
CA 66A-66A						CA 12A-66A-66A				CA 2A-30A-66A-66A			CA_2A-12A-30A-66A-66A		
						CA 30A-66A-66A				CA 12A-30A-66A-66A					
					CA 2A-13A	CA 13A-48A-48A			CA 2A-13A-48A	CA 2A-13A-48A-48A		CA 2A-13A-48A-66A			
					CA 13A-48A				CA 2A-13A-66A	CA 13A-48A-48A-66A					
					CA 13A-66A				CA 13A-48A-66A						
CA 48C					CA 46A-48A				CA 46A-48A-66A				CA_2A-13A-48A-66A		
						CA 13A-48C				CA 2A-48C-66A		CA 2A-13A-48C			
						CA 48C-66A				CA 13A-48C-66A					
						CA 14A-66A-66A				CA 2A-14A-66A-66A		CA 2A-14A-30A-66A-66A			
						CA 5A-48C				CA 5A-48C-66A					
						CA 2A-4A				CA 2A-5A-48C					
						CA 4A-5A				CA 2A-4A-5A					
						CA 4A-30A				CA 2A-4A-30A					
						CA 5A-30A				CA 2A-5A-30A					
						CA 4A-12A				CA 4A-5A-30A					
CA 66B						CA 2A-2A-5A	CA 2A-2A-66A-66A			CA 2A-2A-5A-48C			CA_2A-2A-5A-66A-66A		
						CA 5A-66A-66A				CA 2A-4A-5A		CA 2A-2A-5A-66A			
						CA 2A-66B	CA 2A-2A-66B			CA 2A-4A-30A		CA 2A-5A-66B			
						CA 5A-66B				CA 2A-5A-30A					
						CA 2A-66C	CA 2A-2A-66C			CA 4A-5A-30A		CA 2A-5A-66C			
						CA 5A-66C				CA 2A-4A-12A					
										CA 4A-12A-30A					
										CA 5A-30A-66A					
CA 66C						CA 2A-2A-13A				CA 2A-2A-5A-66A		CA_2A-2A-5A-66A-66A	CA_2A-2A-5A-66B		
						CA 13A-66A-66A				CA 2A-5A-66A-66A		CA 2A-2A-13A-66A			
						CA 13A-66B				CA 2A-13A-66A-66A		CA 2A-13A-66B			
										CA 2A-13A-66B		CA 2A-2A-13A-66B			
										CA 2A-2A-14A-66A		CA 2A-2A-14A-66A-66A			
												CA 2A-5A-46D			
										CA 2A-46D		CA 2A-5A-48A-48C			
										CA 5A-46D		CA 2A-5A-48D			
										CA 2A-48D		CA 2A-5B-66A-66A			
										CA 5A-48D		CA 2A-5B-66B			
CA 48D		CA 48A-48C				CA 5B-66A-66A						CA 2A-5B-66C	CA_2A-5A-48D		
						CA 5B-66B						CA 2A-5B-66B			
						CA 5B-66C						CA 2A-5B-66C			
						CA 13A-48A-48C						CA 2A-13A-48A-48C			
						CA 14A-66A-66A-66A						CA 2A-14A-66A-66A-66A			
						CA 2A-66A-66A-66A						CA_2A-14A-66A-66A-66A			
						CA 2A-46A	CA 2A-46C	CA 2A-46A-46C	CA 2A-46A-66A	CA 2A-46C-66A	CA 2A-46A-46C-66A				
						CA 46A-66A	CA 46C-66A	CA 46A-46C-66A			CA 2A-46A-46C-66A				
											CA 46A-48D				
											CA 46C-48C				
CA 42D					CA 3A-19A							CA 2A-46A-48D	CA_2A-46A-46C-66A		
												CA 2A-46C-48C			
											CA 46D-48A				
											CA 48A-48C-66A				
											CA 48D-66A				
											CA 19A-42D				
											CA 46D-66A				
											CA 5A-46D-66A				
											CA 5A-48D-66A				
											CA 13A-46D-66A				
						CA 48C-66B									
					CA 13A-66C	CA 48C-66C	CA 13A-48C-66C								
						CA 13A-48D	CA 13A-48C-66C								
							CA 13A-48D-66A								
							CA 46A-48D-66A								
							CA 46C-48C-66A								
							CA 46D-48A-66A								
							CA 2A-13A-46D								
							CA 2A-13A-48D								





## Uplink Carrier Aggregation Scenarios Conducted Power (Full)

Configure	Combination	PCC								SCC						Measurement Power		
		Band	BW (MHz)	Modulation	RB Size	RB Offset	UL Channel	UL Frequency (MHz)	Band	BW (MHz)	Modulation	RB Size	RB Offset	UL Channel	UL Frequency (MHz)	Maximum Tune-up Power	Single Carrier Tx Power without UL-CA Active (dBm)	Tx Power with UL-CA Active (dBm)
																		Total
Intra Band Contiguous	CA_5B	5	10	QPSK	1	0	20450	829	5	10	QPSK	1	49	20549	838.9	24.0	23.09	15.10
					1	49						24.0	22.95			22.86		
		5	10	QPSK	1	0	20476	831.6	5	10	QPSK	1	49	20575	841.5	24.0	23.19	15.04
					1	49						24.0	22.91			22.79		
		5	10	QPSK	1	0	20501	834.1	5	10	QPSK	1	49	20600	844	24.0	23.15	15.02
					1	49						24.0	22.92			22.71		
	CA_7C	7	20	QPSK	1	0	20850	2510	7	20	QPSK	1	99	21048	2529.8	24.0	23.01	15.03
					1	99						24.0	22.98			22.80		
		7	20	QPSK	1	0	21001	2525.1	7	20	QPSK	1	99	21199	2544.9	24.0	23.06	14.97
					1	99						24.0	22.98			22.78		
		7	20	QPSK	1	0	21152	2540.2	7	20	QPSK	1	99	21350	2560	24.0	23.17	15.03
					1	99						24.0	23.01			22.81		
	CA_38C	38	20	QPSK	1	0	37850	2580	38	20	QPSK	1	99	38048	2602.5	24.0	23.38	15.32
					1	99						24.0	23.25			22.90		
		38	20	QPSK	1	0	37901	2585.1	38	20	QPSK	1	99	38099	2604.9	24.0	23.25	15.37
					1	99						24.0	23.12			22.82		
		38	20	QPSK	1	0	37952	2590.2	38	20	QPSK	1	99	38150	2610	24.0	23.26	15.38
					1	99						24.0	23.09			22.81		
	CA_41C	41	20	QPSK	1	0	39750	2506	41	20	QPSK	1	99	39948	2525.8	24.0	23.95	16.11
					1	99						24.0	23.84			22.90		
		41	20	QPSK	1	0	40185	2549.5	41	20	QPSK	1	99	40383	2569.3	24.0	23.73	16.04
					1	99						24.0	23.68			22.82		
		41	20	QPSK	1	0	40620	2593	41	20	QPSK	1	99	40818	2612.8	24.0	23.97	16.21
					1	99						24.0	23.89			22.81		
		41	20	QPSK	1	0	41055	2636.5	41	20	QPSK	1	99	41253	2656.3	24.0	23.99	16.06
					1	99						24.0	23.95			22.79		
		41	20	QPSK	1	0	41292	2660.2	41	20	QPSK	1	99	41490	2680	24.0	23.98	15.99
					1	99						24.0	23.91			22.80		
	CA_48C	48	20	QPSK	1	0	55340	3560	48	20	QPSK	1	99	55538	3579.8	22.0	21.47	13.20
					1	99						22.0	21.39			21.32		
		48	20	QPSK	1	0	55830	3609	48	20	QPSK	1	99	55632	3589.2	22.0	21.25	13.21
					1	99						22.0	21.22			21.12		
		48	20	QPSK	1	0	56150	3641	48	20	QPSK	1	99	55952	3621.2	22.0	21.62	13.37
					1	99						22.0	21.51			21.32		
	48	20	QPSK	1	0	56640	3550	48	20	QPSK	1	99	56442	3670.2	22.0	21.85	13.36	
				1	99						22.0	21.81			21.76			
	CA_66B	66	10	QPSK	1	0	132022	1715	66	10	QPSK	1	49	132121	1724.9	24.0	23.11	15.98
					1	49						24.0	23.08			22.84		
		66	10	QPSK	1	0	132373	1750.1	66	10	QPSK	1	49	132472	1760	24.0	23.24	15.84
					1	49						24.0	23.09			22.81		
		66	10	QPSK	1	0	132523	1765.1	66	10	QPSK	1	49	132622	1775	24.0	23.15	15.95
					1	49						24.0	23.11			22.89		

## Uplink Carrier Aggregation Scenarios Conducted Power (Full)

Confugure	Combination	PCC							SCC							Measurement Power		
		Band	BW (MHz)	Modulation	RB Size	RB Offset	UL Channel	UL Frequency (MHz)	Band	BW (MHz)	Modulation	RB Size	RB Offset	UL Channel	UL Frequency (MHz)	Maximum Tune-up Power	Single Carrier Tx Power without UL-CA Active (dBm)	Tx Power with UL-CA Active (dBm)
																	Total	Total
CA_66C	66	20	QPSK	1	0	132072	1720	66	20	QPSK	1	99	132270	1739.8	24.0	23.15	15.78	
															1	99	24.0	23.09
		20	QPSK	1	0	132323	1745.1	66	20	QPSK	1	99	132521	1764.9	24.0	23.25	15.74	
															1	99	24.0	23.16
		20	QPSK	1	0	132374	1750.2	66	20	QPSK	1	99	132572	1770	24.0	23.14	15.78	
															1	99	24.0	23.08
	CA_2A-5A	2	20	QPSK	1	0	18700	1860	5	10	QPSK	1	49	20525	836.5	24.0	23.32	15.88
																1	99	24.0
			20	QPSK	1	0	18900	1880	5	10	QPSK	1	49	20525	836.5	24.0	23.13	15.82
1																99	24.0	22.95
20			QPSK	1	0	19100	1900	5	10	QPSK	1	49	20525	836.5	24.0	23.16	15.76	
															1	99	24.0	22.92
CA_2A-12A		2	20	QPSK	1	0	18700	1860	12	10	QPSK	1	49	23095	707.5	24.0	23.32	15.72
																1	99	24.0
		20	QPSK	1	0	18900	1880	12	10	QPSK	1	49	23095	707.5	24.0	23.13	15.68	
															1	99	24.0	22.95
		20	QPSK	1	0	19100	1900	12	10	QPSK	1	49	23095	707.5	24.0	23.16	15.76	
															1	99	24.0	22.92
CA_2A-13A		2	20	QPSK	1	0	18700	1860	13	10	QPSK	1	49	23230	782	24.0	23.32	15.79
																1	99	24.0
		20	QPSK	1	0	18900	1880	13	10	QPSK	1	49	23230	782	24.0	23.13	15.75	
															1	99	24.0	22.95
		20	QPSK	1	0	19100	1900	13	10	QPSK	1	49	23230	782	24.0	23.16	15.70	
															1	99	24.0	22.92
CA_2A-14A	2	20	QPSK	1	0	18700	1860	14	10	QPSK	1	49	23330	793	24.0	23.32	15.68	
															1	99	24.0	22.81
	20	QPSK	1	0	18900	1880	14	10	QPSK	1	49	23330	793	24.0	23.13	15.61		
														1	99	24.0	22.95	22.74
	20	QPSK	1	0	19100	1900	14	10	QPSK	1	49	23330	793	24.0	23.16	15.63		
														1	99	24.0	22.92	22.79
CA_2A-48A	2	20	QPSK	1	0	18700	1860	48	20	QPSK	1	99	56210	3647	24.0	23.32	15.66	
															1	99	24.0	22.81
	20	QPSK	1	0	18900	1880	48	20	QPSK	1	99	56210	3647	24.0	23.13	15.55		
														1	99	24.0	22.95	22.71
	20	QPSK	1	0	18900	1880	48	20	QPSK	1	99	56210	3647	24.0	23.16	15.62		
														1	99	24.0	22.92	22.74
CA_4A-5A	4	20	QPSK	1	0	20050	1720	5	10	QPSK	1	49	20525	836.5	24.0	23.27	15.50	
															1	99	24.0	22.85
	20	QPSK	1	0	20175	1732.5	5	10	QPSK	1	49	20525	836.5	24.0	23.25	15.40		
														1	99	24.0	22.77	22.70
	20	QPSK	1	0	20300	1745	5	10	QPSK	1	49	20525	836.5	24.0	23.22	15.36		
														1	99	24.0	22.77	22.68

## Uplink Carrier Aggregation Scenarios Conducted Power (Full)

Configure	Combination	PCC							SCC							Measurement Power		
		Band	BW (MHz)	Modulation	RB Size	RB Offset	UL Channel	UL Frequency (MHz)	Band	BW (MHz)	Modulation	RB Size	RB Offset	UL Channel	UL Frequency (MHz)	Maximum Tune-up Power	Single Carrier Tx Power without UL-CA Active (dBm)	Tx Power with UL-CA Active (dBm)
																	Total	Total
Inter Band	CA_4A-12A	4	20	QPSK	1	0	20050	1720	12	10	QPSK	1	49	23095	707.5	24.0	23.27	15.41
						99							0			24.0	22.85	22.68
		4	20	QPSK	1	0	20175	1732.5	12	10	QPSK	1	49	23095	707.5	24.0	23.25	15.46
						99							0			24.0	22.77	22.68
		4	20	QPSK	1	0	20300	1745	12	10	QPSK	1	49	23095	707.5	24.0	23.22	15.40
						99							0			24.0	22.77	22.72
	CA_4A-13A	4	20	QPSK	1	0	20050	1720	13	10	QPSK	1	49	23230	782	24.0	23.27	15.34
						99							0			24.0	22.85	22.78
		4	20	QPSK	1	0	20175	1732.5	13	10	QPSK	1	49	23230	782	24.0	23.25	15.38
						99							0			24.0	22.77	22.69
		4	20	QPSK	1	0	20300	1745	13	10	QPSK	1	49	23230	782	24.0	23.22	15.37
						99							0			24.0	22.77	22.70
	CA_5A-7A	5	10	QPSK	1	0	20450	829	7	20	QPSK	1	99	21100	2535	24.0	23.09	15.32
						49							0			24.0	22.95	22.81
		5	10	QPSK	1	0	20525	836.5	7	20	QPSK	1	99	21100	2535	24.0	23.22	15.28
						49							0			24.0	23.01	22.86
		5	10	QPSK	1	0	20600	844	7	20	QPSK	1	99	21100	2535	24.0	23.17	15.20
						49							0			24.0	22.93	22.78
	CA_5A-30A	5	10	QPSK	1	0	20450	829	30	10	QPSK	1	49	27710	2310	24.0	23.09	15.30
						49							0			24.0	22.95	22.88
		5	10	QPSK	1	0	20525	836.5	30	10	QPSK	1	49	27710	2310	24.0	23.22	15.13
						49							0			24.0	23.01	22.91
		5	10	QPSK	1	0	20600	844	30	10	QPSK	1	49	27710	2310	24.0	23.17	15.17
						49							0			24.0	22.93	22.86
	CA_5A-48A	5	10	QPSK	1	0	20450	829	48	20	QPSK	1	99	56210	3647	24.0	23.09	15.30
						49							0			24.0	22.95	22.81
		5	10	QPSK	1	0	20525	836.5	48	20	QPSK	1	99	56210	3647	24.0	23.22	15.11
						49							0			24.0	23.01	22.84
		5	10	QPSK	1	0	20600	844	48	20	QPSK	1	99	56210	3647	24.0	23.17	15.05
						49							0			24.0	22.93	22.86
	CA_5A-66A	5	10	QPSK	1	0	20450	829	66	20	QPSK	1	99	132322	1745	24.0	23.09	15.13
						49							0			24.0	22.95	22.86
		5	10	QPSK	1	0	20525	836.5	66	20	QPSK	1	99	132322	1745	24.0	23.22	15.05
						49							0			24.0	23.01	22.81
		5	10	QPSK	1	0	20600	844	66	20	QPSK	1	99	132322	1745	24.0	23.17	15.01
						49							0			24.0	22.93	22.90
	CA_12A-30A	12	10	QPSK	1	0	23060	704	30	10	QPSK	1	49	27710	2310	24.0	22.93	15.14
						49							0			24.0	22.74	22.63
		12	10	QPSK	1	0	23095	707.5	30	10	QPSK	1	49	27710	2310	24.0	22.85	15.23
						49							0			24.0	22.65	22.55
		12	10	QPSK	1	0	23130	711	30	10	QPSK	1	49	27710	2310	24.0	23.07	15.08
						49							0			24.0	22.81	22.75



## Uplink Carrier Aggregation Scenarios Conducted Power (Full)

Confugure	Combination	PCC							SCC							Measurement Power		
		Band	BW (MHz)	Modulation	RB Size	RB Offset	UL Channel	UL Frequency (MHz)	Band	BW (MHz)	Modulation	RB Size	RB Offset	UL Channel	UL Frequency (MHz)	Maximum Tune-up Power	Single Carrier Tx Power without UL-CA Active (dBm)	Tx Power with UL-CA Active (dBm)
																	Total	Total
	CA_12A-66A	12	10	QPSK	1	0	23060	704	66	20	QPSK	1	99	132322	1745	24.0	22.93	15.14
					1	49						1	0			24.0	22.74	22.70
		12	10	QPSK	1	0	23095	707.5	66	20	QPSK	1	99	132322	1745	24.0	22.85	15.23
					1	49						1	0			24.0	22.65	22.63
		12	10	QPSK	1	0	23130	711	66	20	QPSK	1	99	132322	1745	24.0	23.07	15.23
					1	49						1	0			24.0	22.81	22.72
	CA_13A-48A	13	10	QPSK	1	0	23230	782	48	20	QPSK	1	99	56210	3647	24.0	23.08	15.18
					1	49						1	0			24.0	22.91	22.80
	CA_13A-66A	13	10	QPSK	1	0	23230	782	66	20	QPSK	1	99	132322	1745	24.0	23.08	15.15
					1	49						1	0			24.0	22.91	22.83
	CA_14A-30A	14	10	QPSK	1	0	23330	793	30	10	QPSK	1	49	27710	2310	24.0	23.04	15.14
					1	99						1	0			24.0	22.89	22.83
	CA_14A-66A	14	10	QPSK	1	0	23330	793	66	20	QPSK	1	99	132322	1745	24.0	23.04	15.17
					1	99						1	0			24.0	22.89	22.80
	CA_48A-66A	48	20	QPSK	1	0	55340	3560	66	20	QPSK	1	99	132322	1745	22.0	21.47	12.90
					1	99						1	0			22.0	21.39	21.30
		48	20	QPSK	1	0	55780	3603	66	20	QPSK	1	99	132322	1745	22.0	21.29	12.88
					1	99						1	0			22.0	21.25	21.20
		48	20	QPSK	1	0	56210	3647	66	20	QPSK	1	99	132322	1745	22.0	21.63	12.70
					1	99						1	0			22.0	21.55	21.50
48		20	QPSK	1	0	56640	3690	66	20	QPSK	1	99	132322	1745	22.0	21.85	12.78	
				1	99						1	0			22.0	21.81	21.62	

## Uplink Carrier Aggregation Scenarios Conducted Power (Laptop)

Configure	Combination	PCC							SCC							Measurement Power		
		Band	BW (MHz)	Modulation	RB Size	RB Offset	UL Channel	UL Frequency (MHz)	Band	BW (MHz)	Modulation	RB Size	RB Offset	UL Channel	UL Frequency (MHz)	Maximum Tune-up Power	Single Carrier Tx Power without UL-CA Active (dBm)	Tx Power with UL-CA Active (dBm)
																		Total
Intra Band Contiguous	CA_5B	5	10	QPSK	1	0	20450	829	5	10	QPSK	1	49	20549	838.9	21.5	21.3	21.21
					1	49						21.5	20.96			20.90		
		5	10	QPSK	1	0	20476	831.6	5	10	QPSK	1	49	20575	841.5	21.5	21.25	21.11
					1	49						21.5	21.01			20.95		
		5	10	QPSK	1	0	20501	834.1	5	10	QPSK	1	49	20600	844	21.5	21.11	21.01
					1	49						21.5	20.98			20.90		
	CA_7C	7	20	QPSK	1	0	20850	2510	7	20	QPSK	1	99	21048	2529.8	18.0	17.82	17.73
					1	99						18.0	17.08			17.01		
		7	20	QPSK	1	0	21001	2525.1	7	20	QPSK	1	99	21199	2544.9	18.0	17.65	17.59
					1	99						18.0	17.14			17.05		
		7	20	QPSK	1	0	21152	2540.2	7	20	QPSK	1	99	21350	2560	18.0	17.81	17.74
					1	99						18.0	17.29			17.21		
	CA_38C	38	20	QPSK	1	0	37850	2580	38	20	QPSK	1	99	38048	2602.5	20.5	20.2	20.10
					1	99						20.5	20.04			19.91		
		38	20	QPSK	1	0	37901	2585.1	38	20	QPSK	1	99	38099	2604.9	20.5	20.03	19.91
					1	99						20.5	19.95			19.85		
		38	20	QPSK	1	0	37952	2590.2	38	20	QPSK	1	99	38150	2610	20.5	20.15	20.06
					1	99						20.5	20.01			19.96		
	CA_41C	41	20	QPSK	1	0	39750	2506	41	20	QPSK	1	99	39948	2525.8	18	17.45	17.41
					1	99						18	17.36			17.30		
		41	20	QPSK	1	0	40185	2549.5	41	20	QPSK	1	99	40383	2569.3	18	17.24	17.15
					1	99						18	17.15			17.06		
		41	20	QPSK	1	0	40620	2593	41	20	QPSK	1	99	40818	2612.8	18	17.34	17.21
					1	99						18	17.25			17.16		
		41	20	QPSK	1	0	41055	2636.5	41	20	QPSK	1	99	41253	2656.3	18	17.6	17.54
					1	99						18	17.51			17.46		
		41	20	QPSK	1	0	41292	2660.2	41	20	QPSK	1	99	41490	2680	18	17.45	17.38
					1	99						18	17.37			17.31		
	CA_48C	48	20	QPSK	1	0	55340	3560	48	20	QPSK	1	99	55538	3579.8	17.5	16.81	16.72
					1	99						17.5	16.7			16.62		
		48	20	QPSK	1	0	55830	3609	48	20	QPSK	1	99	55632	3589.2	17.5	16.69	16.58
					1	99						17.5	16.58			16.47		
		48	20	QPSK	1	0	56150	3641	48	20	QPSK	1	99	55952	3621.2	17.5	16.98	16.84
					1	99						17.5	16.85			16.80		
	48	20	QPSK	1	0	56640	3550	48	20	QPSK	1	99	56442	3670.2	17.5	17.19	17.09	
				1	99						17.5	17.08			17.03			
CA_66B	66	10	QPSK	1	0	132022	1715	66	10	QPSK	1	49	132121	1724.9	18.5	18.17	18.00	
				1	49						18.5	17.96			17.91			
	66	10	QPSK	1	0	132373	1750.1	66	10	QPSK	1	49	132472	1760	18.5	18.19	18.08	
				1	49						18.5	18.06			18.01			
	66	10	QPSK	1	0	132523	1765.1	66	10	QPSK	1	49	132622	1775	18.5	18.16	18.07	
				1	49						18.5	18.02			17.96			

## Uplink Carrier Aggregation Scenarios Conducted Power (Laptop)

Configure	Combination	PCC							SCC							Measurement Power		
		Band	BW (MHz)	Modulation	RB Size	RB Offset	UL Channel	UL Frequency (MHz)	Band	BW (MHz)	Modulation	RB Size	RB Offset	UL Channel	UL Frequency (MHz)	Maximum Tune-up Power	Single Carrier Tx Power without UL-CA Active (dBm)	Tx Power with UL-CA Active (dBm)
																		Total
CA_66C	66	20	QPSK	1	0	132072	1720	66	20	QPSK	1	99	132270	1739.8	18.5	18.21	18.11	
				1	99						18.5	17.99			17.93			
	66	20	QPSK	1	0	132323	1745.1	66	20	QPSK	1	99	132521	1764.9	18.5	18.23	18.15	
				1	99						18.5	18.11			18.05			
	66	20	QPSK	1	0	132374	1750.2	66	20	QPSK	1	99	132572	1770	18.5	18.18	18.10	
				1	99						18.5	18.05			17.97			
CA_2A-5A	2	20	QPSK	1	0	18700	1860	5	10	QPSK	1	49	20525	836.5	18.0	17.85	17.79	
				1	99						18.0	17.81			17.75			
	2	20	QPSK	1	0	18900	1880	5	10	QPSK	1	49	20525	836.5	18.0	17.8	17.71	
				1	99						18.0	17.75			17.67			
	2	20	QPSK	1	0	19100	1900	5	10	QPSK	1	49	20525	836.5	18.0	17.81	17.74	
				1	99						18.0	17.77			17.67			
	CA_2A-12A	2	20	QPSK	1	0	18700	1860	12	10	QPSK	1	49	23095	707.5	18.0	17.85	17.77
					1	99						18.0	17.81			17.70		
		2	20	QPSK	1	0	18900	1880	12	10	QPSK	1	49	23095	707.5	18.0	17.8	17.69
					1	99						18.0	17.75			17.65		
		2	20	QPSK	1	0	19100	1900	12	10	QPSK	1	49	23095	707.5	18.0	17.81	17.70
					1	99						18.0	17.77			17.62		
	CA_2A-13A	2	20	QPSK	1	0	18700	1860	13	10	QPSK	1	49	23230	782	18.0	17.85	17.79
					1	99						18.0	17.81			17.73		
		2	20	QPSK	1	0	18900	1880	13	10	QPSK	1	49	23230	782	18.0	17.8	17.70
					1	99						18.0	17.75			17.67		
		2	20	QPSK	1	0	19100	1900	13	10	QPSK	1	49	23230	782	18.0	17.81	17.76
					1	99						18.0	17.77			17.70		
CA_2A-14A	2	20	QPSK	1	0	18700	1860	14	10	QPSK	1	49	23330	793	18.0	17.85	17.76	
				1	99						18.0	17.81			17.73			
	2	20	QPSK	1	0	18900	1880	14	10	QPSK	1	49	23330	793	18.0	17.8	17.72	
				1	99						18.0	17.75			17.61			
	2	20	QPSK	1	0	19100	1900	14	10	QPSK	1	49	23330	793	18.0	17.81	17.71	
				1	99						18.0	17.77			17.59			
CA_2A-48A	2	20	QPSK	1	0	18700	1860	48	20	QPSK	1	99	56210	3647	18.0	17.85	17.72	
				1	99						18.0	17.81			17.73			
	2	20	QPSK	1	0	18900	1880	48	20	QPSK	1	99	56210	3647	18.0	17.8	17.70	
				1	99						18.0	17.75			17.64			
	2	20	QPSK	1	0	19100	1900	48	20	QPSK	1	99	56210	3647	18.0	17.81	17.67	
				1	99						18.0	17.77			17.64			
CA_4A-5A	4	20	QPSK	1	0	20050	1720	5	10	QPSK	1	49	20525	836.5	18.0	17.81	17.74	
				1	99						18.0	17.69			17.61			
	4	20	QPSK	1	0	20175	1732.5	5	10	QPSK	1	49	20525	836.5	18.0	17.74	17.67	
				1	99						18.0	17.62			17.54			
	4	20	QPSK	1	0	20300	1745	5	10	QPSK	1	49	20525	836.5	18.0	17.75	17.58	
				1	99						18.0	17.63			17.51			

## Uplink Carrier Aggregation Scenarios Conducted Power (Laptop)

Configure	Combination	PCC							SCC							Measurement Power		
		Band	BW (MHz)	Modulation	RB Size	RB Offset	UL Channel	UL Frequency (MHz)	Band	BW (MHz)	Modulation	RB Size	RB Offset	UL Channel	UL Frequency (MHz)	Maximum Tune-up Power	Single Carrier Tx Power without UL-CA Active (dBm)	Tx Power with UL-CA Active (dBm)
																		Total
Inter Band	CA_4A-12A	4	20	QPSK	1	0	20050	1720	12	10	QPSK	1	49	23095	707.5	18.0	17.81	17.74
					1	99						18.0	17.69			17.62		
		4	20	QPSK	1	0	20175	1732.5	12	10	QPSK	1	49	23095	707.5	18.0	17.74	17.65
					1	99						18.0	17.62			17.58		
		4	20	QPSK	1	0	20300	1745	12	10	QPSK	1	49	23095	707.5	18.0	17.75	17.56
					1	99						18.0	17.63			17.49		
	CA_4A-13A	4	20	QPSK	1	0	20050	1720	13	10	QPSK	1	49	23230	782	18.0	17.81	17.72
					1	99						18.0	17.69			17.61		
		4	20	QPSK	1	0	20175	1732.5	13	10	QPSK	1	49	23230	782	18.0	17.74	17.59
					1	99						18.0	17.62			17.52		
		4	20	QPSK	1	0	20300	1745	13	10	QPSK	1	49	23230	782	18.0	17.75	17.67
					1	99						18.0	17.63			17.52		
	CA_5A-7A	5	10	QPSK	1	0	20450	829	7	20	QPSK	1	99	21100	2535	21.5	21.3	21.19
					1	49						21.5	20.96			20.91		
		5	10	QPSK	1	0	20525	836.5	7	20	QPSK	1	99	21100	2535	21.5	21.31	21.26
					1	49						21.5	21.05			21.00		
		5	10	QPSK	1	0	20600	844	7	20	QPSK	1	99	21100	2535	21.5	21.12	21.05
					1	49						21.5	21.01			20.94		
	CA_5A-30A	5	10	QPSK	1	0	20450	829	30	10	QPSK	1	49	27710	2310	21.5	21.3	21.17
					1	49						21.5	20.96			20.9		
		5	10	QPSK	1	0	20525	836.5	30	10	QPSK	1	49	27710	2310	21.5	21.31	21.16
					1	49						21.5	21.05			20.98		
		5	10	QPSK	1	0	20600	844	30	10	QPSK	1	49	27710	2310	21.5	21.12	21.05
					1	49						21.5	21.01			20.96		
	CA_5A-48A	5	10	QPSK	1	0	20450	829	48	20	QPSK	1	99	56210	3647	21.5	21.3	21.20
					1	49						21.5	20.96			20.91		
		5	10	QPSK	1	0	20525	836.5	48	20	QPSK	1	99	56210	3647	21.5	21.31	21.15
					1	49						21.5	21.05			20.99		
		5	10	QPSK	1	0	20600	844	48	20	QPSK	1	99	56210	3647	21.5	21.12	20.99
					1	49						21.5	21.01			20.90		
	CA_5A-66A	5	10	QPSK	1	0	20450	829	66	20	QPSK	1	99	132322	1745	21.5	21.3	21.19
					1	49						21.5	20.96			20.88		
		5	10	QPSK	1	0	20525	836.5	66	20	QPSK	1	99	132322	1745	21.5	21.31	21.21
					1	49						21.5	21.05			20.96		
		5	10	QPSK	1	0	20600	844	66	20	QPSK	1	99	132322	1745	21.5	21.12	21.03
					1	49						21.5	21.01			20.91		
CA_12A-30A	12	10	QPSK	1	0	23060	704	30	10	QPSK	1	49	27710	2310	19.5	19.29	19.19	
				1	49						19.5	19.02			19.01			
	12	10	QPSK	1	0	23095	707.5	30	10	QPSK	1	49	27710	2310	19.5	19.33	19.22	
				1	49						19.5	18.91			18.83			
	12	10	QPSK	1	0	23130	711	30	10	QPSK	1	49	27710	2310	19.5	19.35	19.26	
				1	49						19.5	19.07			19.01			

## Uplink Carrier Aggregation Scenarios Conducted Power (Laptop)

Configuure	Combination	PCC							SCC							Measurement Power		
		Band	BW (MHz)	Modulation	RB Size	RB Offset	UL Channel	UL Frequency (MHz)	Band	BW (MHz)	Modulation	RB Size	RB Offset	UL Channel	UL Frequency (MHz)	Maximum Tune-up Power	Single Carrier Tx Power without UL-CA Active (dBm)	Tx Power with UL-CA Active (dBm)
																		Total
	CA_12A-66A	12	10	QPSK	1	0	23060	704	66	20	QPSK	1	99	132322	1745	19.5	19.29	19.19
					1	49						19.5	19.02			18.94		
		12	10	QPSK	1	0	23095	707.5	66	20	QPSK	1	99	132322	1745	19.5	19.33	19.25
					1	49						19.5	18.91			18.78		
		12	10	QPSK	1	0	23130	711	66	20	QPSK	1	99	132322	1745	19.5	19.35	19.23
					1	49						19.5	19.07			18.95		
	CA_13A-48A	13	10	QPSK	1	0	23230	782	48	20	QPSK	1	99	56210	3647	20	19.98	19.91
					1	49						20	19.83			19.75		
	CA_13A-66A	13	10	QPSK	1	0	23230	782	66	20	QPSK	1	99	132322	1745	20	19.98	19.85
					1	49						20	19.83			19.70		
	CA_14A-30A	14	10	QPSK	1	0	23330	793	30	10	QPSK	1	49	27710	2310	23	22.67	22.60
					1	49						23	22.6			22.56		
	CA_14A-66A	14	10	QPSK	1	0	23330	793	66	20	QPSK	1	99	132322	1745	23	22.67	22.57
					1	49						23	22.6			22.50		
	CA_48A-66A	48	20	QPSK	1	0	55340	3560	66	20	QPSK	1	99	132322	1745	17.5	16.81	16.74
					1	99						17.5	16.7			16.60		
		48	20	QPSK	1	0	55780	3603	66	20	QPSK	1	99	132322	1745	17.5	16.73	16.56
					1	99						17.5	16.62			16.50		
		48	20	QPSK	1	0	56210	3647	66	20	QPSK	1	99	132322	1745	17.5	16.99	16.92
					1	99						17.5	16.88			16.78		
48		20	QPSK	1	0	56640	3690	66	20	QPSK	1	99	132322	1745	17.5	17.19	17.01	
				1	99						17.5	17.08			16.97			

### Downlink Carrier Aggregation Scenarios Conducted Power (Full)

Configure	Combination	PCC								SCC1				SCC2				SCC3				SCC4				Measurement Power						
		LTE Band	BW [Mhz]	UL Channel	UL Freq. [MHz]	UL RB	UL Offset	DL Channel	DL Freq. [MHz]	LTE Band	BW [Mhz]	DL Channel	DL Freq. [MHz]	LTE Band	BW [Mhz]	DL Channel	DL Freq. [MHz]	LTE Band	BW [Mhz]	DL Channel	DL Freq. [MHz]	LTE Band	BW [Mhz]	DL Channel	DL Freq. [MHz]	LTE Band	BW [Mhz]	DL Channel	DL Freq. [MHz]	Maximum Tune-up Power	Single Carrier Tx Power without DL-CA Active (dBm)	Tx Power with DL-CA Active (dBm)
																														Total		
Intra Band Contiguous	CA_38C	38	20	38150	2610	1	0	38150	2610	38	20	37952	2590.2																24.0	23.27	23.13	
	CA_41E	41	20	39750	2506	1	0	39750	2506	41	20	39950	2526	41	20	40150	2546	41	20	40350	2566								24.0	23.95	23.81	
	CA_41F	41	20	39750	2506	1	0	39750	2506	41	20	39948	2525.6	41	20	40146	2545.6	41	20	40344	2565.4	41	20	40542	2585.2	24.0	23.95	23.83				
	CA_48F	48	20	55340	3560	1	0	55340	3560	48	20	55538	3579.8	48	20	55736	3599.6	48	20	55934	3619.4	48	20	56132	3639.2	22.0	21.47	21.42				
Intra Band Non-Contiguous	CA_25A-25A	25	20	26140	1860	1	0	8140	1940	25	20	8590	1985															24.0	22.41	22.35		
	CA_41A-41A	41	20	39750	2506	1	0	39750	2506	41	20	41490	2680															24.0	23.95	23.91		
	CA_41A-41C	41	20	39750	2506	1	0	39750	2506	41	20	41292	2660.2	41	20	41490	2680											24.0	23.95	23.85		
	CA_48A-48A-48A	48	20	55340	3560	1	0	55340	3560	48	20	55780	3603	48	20	56640	3690											22.0	21.47	21.35		
	CA_66A-66C	66	20	132072	17200	1	0	66536	2120	66	20	67038	2170.2	66	20	67236	2190											24.0	23.15	23.05		
	CA_41A-41D	41	20	39750	2506	1	0	39750	2506	41	20	41094	2640.4	41	20	41292	2660.2	41	20	41490	2680							24.0	23.95	23.83		
	CA_41C-41C	41	20	39750	2506	1	0	39750	2506	41	20	39948	2525.8	41	20	41292	2660.2	41	20	41490	2680							24.0	23.95	23.88		
	CA_48A-48A-48C	48	20	55340	3560	1	0	55340	3560	48	20	55780	3603	48	20	56442	3670.2	48	20	56640	3690							22.0	21.47	21.41		
	CA_48A-48A-48D	48	20	55340	3560	1	0	55340	3560	48	20	55780	3603	48	20	56244	3650.4	48	20	56442	3670.2	48	20	56640	3690	22.0	21.47	21.43				
	CA_48A-48C-48C	48	20	55340	3560	1	0	55340	3560	48	20	55780	3603	48	20	55968	3622.8	48	20	56442	3670.2	48	20	56640	3690	22.0	21.47	21.37				
	CA_2A-7A	2	20	19100	1900	1	0	1100	1980	7	20	3100	2655															24.0	23.16	23.05		
	CA_4A-48A	4	20	20050	1720	1	0	2050	2120	48	20	56210	3647															24.0	23.27	23.11		
Intra Band Non-Contiguous	CA_25A-26A	25	20	26140	1860	1	0	8140	1940	26	15	8865	876.5															24.0	22.41	22.34		
	CA_41A-46A	41	20	39750	2506	1	0	39750	2506	46	20	46890	5160															24.0	23.95	23.91		
	CA_26A-41A	26	15	26765	821.5	1	0	8765	866.5	41	20	40620	2593															24.0	23.09	23.02		
	CA_2A-2A-46A	2	20	19100	1900	1	0	1100	1980	2	20	900	1960	46	20	46890	5160											24.0	23.16	23.07		
	CA_4A-4A-13A	4	20	20050	17200	1	0	2050	2120	4	20	2300	2145	13	10	5230	751											24.0	23.27	23.22		
	CA_4A-46A-46A	4	20	20050	17200	1	0	2050	2120	46	20	46890	5160	46	20	54340	5905											24.0	23.27	23.15		
	CA_4A-46C	4	20	20050	17200	1	0	2050	2120	46	20	46890	5160	46	20	47088	5179.8											24.0	23.27	23.18		
	CA_4A-48C	4	20	20050	17200	1	0	2050	2120	48	20	56210	3647	48	20	56012	3627.2											24.0	23.27	23.16		
	CA_5A-7A-7A	5	10	20450	829	1	0	2450	874	7	20	3100	2655	7	20	3350	2680											24.0	23.09	23.05		
	CA_5B-46A	5	10	20450	829	1	0	2450	874	5	10	2549	883.9	46	20	46890	5160											24.0	23.09	23.01		
	CA_26A-41C	26	15	26765	821.5	1	0	8765	866.5	41	20	41292	2660.2	41	20	41490	2680											24.0	23.09	22.98		
	CA_41A-46C	41	20	39750	2506	1	0	39750	2506	46	20	46890	5160	46	20	47088	5179.8											24.0	23.95	23.86		
	CA_2A-2A-4A-4A	2	20	19100	1900	1	0	1100	1980	2	20	900	1960	4	20	2050	2120	4	20	2300	2145							24.0	23.16	23.06		
	CA_2A-46A-46A-66A	2	20	19100	1900	1	0	1100	1980	46	20	46890	5160	46	20	54340	5905	66	20	67036	2170							24.0	23.16	23.01		
	CA_2C-66A-66A	2	20	19100	1900	1	0	1100	1980	2	20	898	1959.8	66	20	66536	2120	66	20	67236	2190							24.0	23.16	22.98		
	CA_4A-4A-5B	4	20	20050	1720	1	0	2050	2120	4	20	2300	2145	5	10	2476	876.6	5	10	2575	886.5							24.0	23.27	23.12		
	CA_4A-46A-46C	4	20	20050	1720	1	0	2050	2120	46	20	46890	5160	46	20	50692	5540.2	46	20	50892	5560							24.0	23.27	23.22		
	CA_4A-46D	4	20	20050	1720	1	0	2050	2120	46	20	53942	5865.2	46	20	54140	5885	46	20	54338	5904.8							24.0	23.27	23.12		
	CA_4A-48D	4	20	20050	1720	1	0	2050	2120	48	20	56244	3650.4	48	20	56442	3670.2	48	20	56640	3690							24.0	23.27	23.16		
	CA_5A-5A-66A-66A	5	10	20450	829	1	0	2450	874	5	10	2600	889	66	20	66536	2120	66	20	67236	2190							24.0	23.09	23.01		
	CA_5A-5A-66B	5	10	20450	829	1	0	2450	874	5	10	2600	889	66	10	67086	2175	66	10	66987	2165.1							24.0	23.09	22.94		
	CA_5A-5A-66C	5	10	20450	829	1	0	2450	874	5	10	2600	889	66	20	67036	2170	66	20	66838	2150.2							24.0	23.09	22.99		
	CA_5B-46C	5	10	20450	829	1	0	2450	874	5	10	2549	883.9	46	20	50692	5540.2	46	20	50892	5560							24.0	23.09	22.96		
	CA_30A-66A-66A-66A	30	10	27710	2310	1	0	8920	2355	66	20	67036	2170	66	20	66786	2145	66	20	66536	2120							24.0	22.71	22.65		
	CA_48A-48A-66A-66A	48	20	55340	3560	1	0	55340	3560	48	20	56640	3690	66	20	66786	2145	66	20	66536	2120							22.0	21.47	21.41		
	CA_48A-48A-66B	48	20	55340	3560	1	0	55340	3560	48	20	56640	3690	66	10	67086	2175	66	10	66987	2165.1							22.0	21.47	21.33		
	CA_48A-48A-66C	48	20	55340	3560	1	0	55340	3560	48	20	56640	3690	66	20	67036	2170	66	20	66838	2150.2							22.0	21.47	21.36		
	CA_48A-66A-66A-66A	48	20	55340	3560	1	0	55340	3560	66	20	67036	2170	66	20	66786	2145	66	20	66536	2120							22.0	21.47	21.38		
	CA_2A-2A-46D	2	20	19100	1900	1	0	1100	1980	2	20	900	1960	46	20	53942	5865.2	46	20	54140	5885	46	20	54338	5904.8			24.0	23.16	23.05		
	CA_2A-46A-46D	2	20	19100	1900	1	0	1100	1980	46	20	50665	5537.5	46	20	53942	5865.2	46	20	54140	5885	46	20	54338	5904.8			24.0	23.16	23.01		
	CA_2A-46C-46C	2	20	19100	1900	1	0	1100	1980	46	20	46890	5160	46	20	47088	5179.8	46	20	54142	5885.2	46	20	54340	5905			24.0	23.16	22.98		
	CA_2A-46E	2	20	19100	1900	1	0	1100	1980	46	20	53740	5845	46	20	53941	5865.1	46	20	54142	5885.2	46	20	54340	5905			24.0	23.16	23.06		
	CA_2A-48A-48D	2	20	19100	1900	1	0	1100	1980	48	20	55340	3560	48	20	56244	3650.4	48	20	56442	3670.2	48	20	56640	3690			24.0	23.16	23.02		
	CA_2A-48C-48C	2	20	19100	1900	1	0	1100	1980	48	20	55340	3560	48	20	55538	3579.8	48	20	56210	3647	48	20	56408	3666.8			24.0	23.16	23.11		
	CA_2A																															

**Downlink Carrier Aggregation Scenarios Conducted Power (Full)**

Configure	Combination	PCC								SCC1				SCC2				SCC3				SCC4				Measurement Power			
		LTE Band	BW [MHz]	UL Channel	UL Freq. [MHz]	UL RB	UL Offset	DL Channel	DL Freq. [MHz]	LTE Band	BW [MHz]	DL Channel	DL Freq. [MHz]	LTE Band	BW [MHz]	DL Channel	DL Freq. [MHz]	LTE Band	BW [MHz]	DL Channel	DL Freq. [MHz]	LTE Band	BW [MHz]	DL Channel	DL Freq. [MHz]	Maximum Tune-up Power	Single Carrier Tx Power without DL-CA Active (dBm)	Tx Power with DL-CA Active (dBm)	
																												Total	
Inter Band	CA_48A-48C-66B	48	20	55340	3560	1	0	55340	3560	48	20	56210	3647	48	20	56408	3666.8	66	10	67086	2175	66	10	66987	2165.1	22.0	21.47	21.41	
	CA_48A-48C-66C	48	20	55340	3560	1	0	55340	3560	48	20	56210	3647	48	20	56408	3666.8	66	20	67036	2170	66	20	66838	2150.2	22.0	21.47	21.33	
	CA_48A-48D-66A	48	20	55340	3560	1	0	55340	3560	48	20	56244	3650.4	48	20	56442	3670.2	48	20	56640	3690	66	20	67036	2170	22.0	21.47	21.35	
	CA_48C-48C-66A	48	20	55340	3560	1	0	55340	3560	48	20	55538	3579.8	48	20	56210	3647	48	20	56408	3666.8	66	20	67036	2170	22.0	21.47	21.29	
	CA_48C-66A-66A-66A	48	20	55340	3560	1	0	55340	3560	48	20	55538	3579.8	66	20	67036	2170	66	20	66786	2145	66	20	66536	2120	22.0	21.47	21.31	
	CA_48E-66A	48	20	55340	3560	1	0	55340	3560	48	20	55538	3579.8	48	20	55736	3599.6	48	20	55934	3619.4	66	20	67036	2170	22.0	21.47	21.38	
	CA_2A-4A-7A	2	20	19100	1900	1	0	1100	1980	4	20	2175	2132.5	7	20	3100	2655										24.0	23.16	23.05
	CA_2A-4A-13A	2	20	19100	1900	1	0	1100	1980	4	20	2175	2132.5	13	10	5230	751										24.0	23.16	23.01
	CA_2A-5A-46A	2	20	19100	1900	1	0	1100	1980	5	10	2450	874	46	20	50665	5537.5										24.0	23.16	23.11
	CA_2A-13A-46A	2	20	19100	1900	1	0	1100	1980	13	10	5230	751	46	20	50665	5537.5										24.0	23.16	23.06
	CA_2A-29A-30A	2	20	19100	1900	1	0	1100	1980	29	10	9715	722.5	30	10	9820	2355										24.0	23.16	23.04
	CA_2A-46A-48A	2	20	19100	1900	1	0	1100	1980	46	20	50665	5537.5	48	20	56210	3647										24.0	23.16	23.11
	CA_4A-7A-28A	4	20	20050	1720	1	0	2050	2120	7	20	3100	2655	28	20	9435	780.5										24.0	23.27	23.14
	CA_4A-29A-30A	4	20	20050	1720	1	0	2050	2120	29	10	9715	722.5	30	10	9820	2355										24.0	23.27	23.13
	CA_5A-46A-66A	5	10	20450	829	1	0	2450	874	46	20	50665	5537.5	66	20	67036	2170										24.0	23.09	22.95
	CA_13A-46A-66A	13	10	23230	782	1	0	5230	751	46	20	50665	5537.5	66	20	67036	2170										24.0	23.08	22.91
	CA_2A-2A-4A-5A	2	20	19100	1900	1	0	1100	1980	2	20	900	1960	4	20	2175	2132.5	5	10	2450	874						24.0	23.16	23.06
	CA_2A-2A-4A-12A	2	20	19100	1900	1	0	1100	1980	2	20	900	1960	4	20	2175	2132.5	12	10	5094	737.4						24.0	23.16	23.01
	CA_2A-2A-46C	2	20	19100	1900	1	0	1100	1980	2	20	900	1960	46	20	54142	5885.2	46	20	54340	5905						24.0	23.16	23.02
	CA_2A-4A-4A-5A	2	20	19100	1900	1	0	1100	1980	4	20	2050	2120	4	20	2300	2145	5	10	2450	874						24.0	23.16	22.98
	CA_2A-4A-4A-12A	2	20	19100	1900	1	0	1100	1980	4	20	2050	2120	4	20	2300	2145	12	10	5094	737.4						24.0	23.16	23.06
	CA_2A-4A-5B	2	20	19100	1900	1	0	1100	1980	4	20	2175	2132.5	5	10	2450	874	5	10	2549	883.9						24.0	23.16	23.09
	CA_2A-5A-46C	2	20	19100	1900	1	0	1100	1980	5	10	2549	883.9	46	20	54142	5885.2	46	20	54340	5905						24.0	23.16	23.02
	CA_2A-12A-66C	2	20	19100	1900	1	0	1100	1980	12	10	5094	737.4	66	20	67036	2170	66	20	66838	2150.2						24.0	23.16	22.94
	CA_2A-13A-46C	2	20	19100	1900	1	0	1100	1980	13	10	5230	751	46	20	54142	5885.2	46	20	54340	5905						24.0	23.16	22.99
	CA_2A-13A-66C	2	20	19100	1900	1	0	1100	1980	13	10	5230	751	66	20	67036	2170	66	20	66838	2150.2						24.0	23.16	22.96
	CA_2A-46A-48C	2	20	19100	1900	1	0	1100	1980	46	20	46890	5160	48	20	56442	3670.2	48	20	56640	3690						24.0	23.16	23.01
	CA_2A-46C-48A	2	20	19100	1900	1	0	1100	1980	46	20	50665	5537.5	46	20	50863	5557.3	48	20	56210	3647						24.0	23.16	22.98
	CA_4A-4A-12A-30A	4	20	20050	1720	1	0	2050	2120	4	20	2300	2145	12	10	5094	737.4	30	10	9820	2355						24.0	23.27	23.14
	CA_5A-46C-66A	5	10	20450	829	1	0	2450	874	46	20	50665	5537.5	46	20	50863	5557.3	66	20	67036	2170						24.0	23.09	23.02
	CA_13A-46C-66A	13	10	23230	782	1	0	5230	751	46	20	50665	5537.5	46	20	50863	5557.3	66	20	67036	2170						24.0	23.08	23.02
	CA_13A-46A-66B	13	10	23230	782	1	0	5230	751	48	20	56210	3647	66	10	67086	2175	66	10	66987	2165.1						24.0	23.08	22.94
	CA_13A-48A-66C	13	10	23230	782	1	0	5230	751	48	20	56210	3647	66	20	67036	2170	66	20	66838	2150.2						24.0	23.08	22.87
	CA_2A-2A-5A-66A-66A	2	20	19100	1900	1	0	1100	1980	2	20	900	1960	5	10	2450	874	66	20	67036	2170	66	20	66786	2145	24.0	23.16	23.02	
	CA_2A-2A-5A-66B	2	20	19100	1900	1	0	1100	1980	2	20	900	1960	5	10	2450	874	66	10	67086	2175	66	10	66987	2165.1	24.0	23.16	22.97	
	CA_2A-2A-5A-66C	2	20	19100	1900	1	0	1100	1980	2	20	900	1960	5	10	2450	874	66	20	67036	2170	66	20	66838	2150.2	24.0	23.16	22.91	
	CA_2A-2A-12A-66A-66A	2	20	19100	1900	1	0	1100	1980	2	20	900	1960	12	10	5094	737.4	66	20	67036	2170	66	20	66786	2145	24.0	23.16	22.98	
	CA_2A-2A-13A-66A-66A	2	20	19100	1900	1	0	1100	1980	2	20	900	1960	13	10	5230	751	66	20	67036	2170	66	20	66786	2145	24.0	23.16	23.06	
	CA_2A-2A-13A-66B	2	20	19100	1900	1	0	1100	1980	2	20	900	1960	13	10	5230	751	66	10	67086	2175	66	10	66987	2165.1	24.0	23.16	23.02	
	CA_2A-2A-14A-66A-66A	2	20	19100	1900	1	0	1100	1980	2	20	900	1960	14	10	5330	763	66	20	67036	2170	66	20	66786	2145	24.0	23.16	22.99	
	CA_2A-5A-46D	2	20	19100	1900	1	0	1100	1980	5	10	2450	874	46	20	53942	5865.2	46	20	54140	5885	46	20	54338	5904.8	24.0	23.16	23.01	
	CA_2A-5A-48A-48C	2	20	19100	1900	1	0	1100	1980	5	10	2450	874	48	20	56210	3647	48	20	56442	3670.2	48	20	56640	3690	24.0	23.16	22.91	
	CA_2A-5A-48D	2	20	19100	1900	1	0	1100	1980	5	10	2450	874	48	20	56244	3650.4	48	20	56442	3670.2	48	20	56640	3690	24.0	23.16	22.85	
	CA_2A-5B-66A-66A	2	20	19100	1900	1	0	1100	1980	5	10	2450	874	5	10	2549	883.9	66	20	67036	2170	66	20	66786	2145	24.0	23.16	22.96	
	CA_2A-5B-66B	2	20	19100	1900	1	0	1100	1980	5	10	2450	874	5	10	2549	883.9	66	10	67086	2175	66	10	66987	2165.1	24.0	23.16	22.89	
	CA_2A-5B-66C	2	20	19100	1900	1	0	1100	1980	5	10	2450	874	5	10	2549	883.9	66	20	67036	2170	66	20	66838	2150.2	24.0	23.16	23.03	
	CA_2A-13A-48A-48C	2	20	19100	1900	1	0	1100	1980	13	10	5230	751	48	20	56210	3647	48	20	56442	3670.2	48	20	56640	3690	24.0	23.16	22.97	
	CA_2A-14A-66A-66A-66A	2	20	19100	1900	1	0	1100	1980	14	10	5330	763	66	20	67036	2170	66	20	66786	2145	66	20	66536	2120	24.0	23.16	22.91	
	CA_2A-46A-46C-66A	2	20	19100	1900	1	0	1100	1980	46	20	46890	5160	46	20	50892	5540.2	46	20	67036	2170	24.0					24.0	23.16	22.84
	CA_2A-46A-48D	2	20	19100	1900	1	0	1100	1980	46	20	46890	5160	48	20	56244	3650.4	48	20	56442	3670.2	48	20	56640	3690	24.0	23.16	22.85	
CA_2A-46C-48																													

**Downlink Carrier Aggregation Scenarios Conducted Power (Full)**

Configure	Combination	PCC									SCC1				SCC2				SCC3				SCC4				Measurement Power		
		LTE Band	BW [Mhz]	UL Channel	UL Freq. [MHz]	UL RB	UL Offset	DL Channel	DL Freq. [MHz]	LTE Band	BW [Mhz]	DL Channel	DL Freq. [MHz]	LTE Band	BW [Mhz]	DL Channel	DL Freq. [MHz]	LTE Band	BW [Mhz]	DL Channel	DL Freq. [MHz]	LTE Band	BW [Mhz]	DL Channel	DL Freq. [MHz]	Maximum Tune-up Power	Single Carrier Tx Power without DL-CA Active (dBm)	Tx Power with DL-CA Active (dBm)	
																												Total	
	CA_2A-13A-48D	2	20	19100	1900	1	0	1100	1980	13	10	5230	751	48	20	56244	3650.4	48	20	56442	3670.2	48	20	56640	3690	24.0	23.16	23.01	
	CA_5A-48A-48C-66A	5	10	20450	829	1	0	2450	874	48	20	56210	3647	48	20	56442	3670.2	48	20	56640	3690	66	20	67036	2170	24.0	23.09	22.94	
	CA_13A-48A-48C-66A	13	10	23230	782	1	0	5230	751	48	20	56210	3647	48	20	56442	3670.2	48	20	56640	3690	66	20	67036	2170	24.0	23.08	22.97	
	CA_2A-4A-5A-30A	2	20	19100	1900	1	0	1100	1980	4	20	2175	2132.5	5	10	2450	874	30	10	9820	2355					24.0	23.16	23.11	
	CA_2A-4A-12A-30A	2	20	19100	1900	1	0	1100	1980	4	20	2175	2132.5	12	10	5094	737.4	30	10	9820	2355					24.0	23.16	23.13	
	CA_2A-5A-30A-66A	2	20	19100	1900	1	0	1100	1980	5	10	2450	874	30	10	9820	2355	66	20	67036	2170					24.0	23.16	23.05	
	CA_2A-5A-48A-48A-66A	2	20	19100	1900	1	0	1100	1980	5	10	2450	874	48	20	55780	3603	48	20	56640	3690	66	20	67036	2170	24.0	23.16	23.07	
	CA_2A-5B-30A-66A	2	20	19100	1900	1	0	1100	1980	5	10	2450	874	5	10	2549	883.9	30	10	9820	2355	66	20	67036	2170	24.0	23.16	22.96	
	CA_2A-12A-30A-66A-66A	2	20	19100	1900	1	0	1100	1980	12	10	5094	737.4	30	10	9820	2355	66	20	67036	2170	66	20	66786	2145	24.0	23.16	23.02	
	CA_2A-13A-48A-48A-66A	2	20	19100	1900	1	0	1100	1980	13	10	5230	751	48	20	56210	3647	48	20	56012	3627.2	66	20	67036	2170	24.0	23.16	22.99	
	CA_2A-13A-48C-66A	2	20	19100	1900	1	0	1100	1980	13	10	5230	751	48	20	56442	3670.2	48	20	56640	3690	66	20	67036	2170	24.0	23.16	22.91	
	CA_2A-14A-30A-66A-66A	2	20	19100	1900	1	0	1100	1980	14	10	5330	763	30	10	9820	2355	66	20	67036	2170	66	20	66786	2145	24.0	23.16	22.85	
	CA_2A-5A-48C-66A	2	20	19100	1900	1	0	1100	1980	5	10	2450	874	48	20	56442	3670.2	48	20	56640	3690	66	20	67036	2170	24.0	23.16	22.93	
																												-	



### Downlink Carrier Aggregation Scenarios Conducted Power (Laptop)

Configure	Combination	PCC								SCC1				SCC2				SCC3				SCC4				Measurement Power						
		LTE Band	BW [Mhz]	UL Channel	UL Freq. [MHz]	UL RB	UL Offset	DL Channel	DL Freq. [MHz]	LTE Band	BW [Mhz]	DL Channel	DL Freq. [MHz]	LTE Band	BW [Mhz]	DL Channel	DL Freq. [MHz]	LTE Band	BW [Mhz]	DL Channel	DL Freq. [MHz]	LTE Band	BW [Mhz]	DL Channel	DL Freq. [MHz]	LTE Band	BW [Mhz]	DL Channel	DL Freq. [MHz]	Maximum Tune-up Power	Single Carrier Tx Power without DL-CA Active (dBm)	Tx Power with DL-CA Active (dBm)
																																Total
Intra Band Contiguous	CA_38C	38	20	38000	2595	1	0	38000	2595	38	20	37952	2590.2																20.5	20.05	19.98	
	CA_41E	41	20	40620	2593	1	0	40620	2593	41	20	40818	2612.8	41	20	41016	2632.6	41	20	41214	2652.4								18.0	17.34	17.22	
	CA_41F	41	20	40620	2593	1	0	40620	2593	41	20	40818	2612.8	41	20	41016	2632.6	41	20	41214	2652.4	41	20	41412	2672.2				18.0	17.34	17.13	
	CA_48F	48	20	56210	3647	1	0	56210	3647	48	20	56012	3627.2	48	20	55814	3607.4	48	20	55616	3587.6	48	20	55418	3567.8				17.5	16.99	16.85	
Intra Band Non-Contiguous	CA_25A-25A	25	20	26365	1882.5	1	0	8365	1962.5	25	20	8590	1965																18.5	18.02	17.95	
	CA_41A-41A	41	20	40620	2593	1	0	40620	2593	41	20	41490	2680																18.0	17.34	17.23	
	CA_41A-41C	41	20	40620	2593	1	0	40620	2593	41	20	41292	2680.2	41	20	41490	2680												18.0	17.34	17.15	
	CA_48A-48A-48A	48	20	56210	3647	1	0	56210	3647	48	20	55780	3603	48	20	56640	3690													17.5	16.99	16.84
	CA_66A-66C	66	20	132322	1745	1	0	66786	2145	66	20	67038	2170.2	66	20	67236	2190													18.5	18.24	18.03
	CA_41A-41D	41	20	40620	2593	1	0	40620	2593	41	20	41094	2640.4	41	20	41292	2660.2	41	20	41490	2680									18.0	17.34	17.27
	CA_41C-41C	41	20	40620	2593	1	0	40620	2593	41	20	40818	2612.8	41	20	41292	2660.2	41	20	41490	2680									18.0	17.34	17.23
	CA_48A-48A-48C	48	20	56210	3647	1	0	56210	3647	48	20	55780	3603	48	20	56442	3670.2	48	20	56640	3690									17.5	16.99	16.91
	CA_48A-48A-48D	48	20	56210	3647	1	0	56210	3647	48	20	55780	3603	48	20	56244	3650.4	48	20	56442	3670.2	48	20	56640	3690				17.5	16.99	16.85	
	CA_48A-48C-48C	48	20	56210	3647	1	0	56210	3647	48	20	55780	3603	48	20	55968	3622.8	48	20	56442	3670.2	48	20	56640	3690				17.5	16.99	16.89	
	CA_2A-7A	2	20	18900	1880	1	0	900	1960	7	20	3100	2655																	18.0	17.80	17.72
	Inter Band	CA_4A-48A	4	20	20175	1732.5	1	0	2175	2132.5	48	20	56210	3647																18.0	17.74	17.65
CA_25A-26A		25	20	26365	1882.5	1	0	8365	1962.5	26	15	8665	876.5																18.5	18.02	17.91	
CA_41A-46A		41	20	40620	2593	1	0	40620	2593	46	20	46890	5160																18.0	17.34	17.25	
CA_26A-41A		26	15	26865	831.5	1	0	8665	876.5	41	20	40620	2593																23.0	22.82	22.73	
CA_2A-2A-46A		2	20	18900	1880	1	0	900	1960	2	20	700	1940	46	20	46890	5160													18.0	17.80	17.66
CA_4A-4A-13A		4	20	20300	1745	1	0	2300	2145	4	20	2050	2145	13	10	5230	751												18.0	17.75	17.61	
CA_4A-4A-46A		4	20	20175	1732.5	1	0	2175	2132.5	46	20	46890	5160	46	20	54340	5905												18.0	17.74	17.71	
CA_4A-46C		4	20	20175	1732.5	1	0	2175	2132.5	46	20	46890	5160	46	20	47088	5179.8												18.0	17.74	17.63	
CA_4A-48C		4	20	20175	1732.5	1	0	2175	2132.5	48	20	56210	3647	48	20	56012	3627.2												18.0	17.74	17.59	
CA_5A-7A-7A		5	10	20525	836.5	1	0	2525	881.5	7	20	3100	2655	7	20	3350	2680												21.5	21.31	21.23	
CA_5B-46A		5	10	20525	836.5	1	0	2525	881.5	5	10	2549	883.9	46	20	46890	5160												21.5	21.31	21.17	
CA_26A-41C		26	15	26865	831.5	1	0	8665	876.5	41	20	41292	2660.2	41	20	41490	2680												23.0	22.82	22.76	
CA_41A-46C		41	20	40620	2593	1	0	40620	2593	46	20	46890	5160	46	20	47088	5179.8												18.0	17.34	17.31	
CA_2A-2A-4A-4A		2	20	18900	1880	1	0	900	1960	2	20	700	1940	4	20	2050	2120	4	20	2300	2145								18.0	17.80	17.59	
CA_2A-46A-46A-66A		2	20	18900	1880	1	0	900	1960	46	20	46890	5160	46	20	54340	5905	66	20	67036	2170							18.0	17.80	17.63		
CA_2C-66A-66A		2	20	18900	1880	1	0	900	1960	2	20	1100	1980	66	20	66536	2120	66	20	67236	2190								18.0	17.80	17.66	
CA_4A-4A-5B		4	20	20300	1745	1	0	2300	2145	4	20	2050	2145	5	10	2476	876.6	5	10	2575	886.5								18.0	17.75	17.63	
CA_4A-46A-46C		4	20	20175	1732.5	1	0	2175	2132.5	46	20	46890	5160	46	20	50892	5540.2	46	20	50892	5560								18.0	17.74	17.65	
CA_4A-46D		4	20	20175	1732.5	1	0	2175	2132.5	46	20	53942	5865.2	46	20	54140	5885	46	20	54338	5904.8								18.0	17.74	17.57	
CA_4A-48D		4	20	20175	1732.5	1	0	2175	2132.5	48	20	56244	3650.4	48	20	56442	3670.2	48	20	56640	3690								18.0	17.74	17.52	
CA_5A-5A-66A-66A		5	10	20525	836.5	1	0	2525	881.5	5	10	2600	889	66	20	66536	2120	66	20	67236	2190								21.5	21.31	21.22	
CA_5A-5A-66B		5	10	20525	836.5	1	0	2525	881.5	5	10	2600	889	66	10	67086	2175	66	10	66987	2165.1							21.5	21.31	21.25		
CA_5A-5A-66C		5	10	20525	836.5	1	0	2525	881.5	5	10	2600	889	66	20	67036	2170	66	20	66838	2150.2							21.5	21.31	21.17		
CA_5B-46C		5	10	20525	836.5	1	0	2525	881.5	5	10	2549	883.9	46	20	50892	5540.2	46	20	50892	5560							21.5	21.31	21.11		
CA_30A-66A-66A-66A		30	10	27710	2310	1	0	8920	2355	66	20	67036	2170	66	20	66786	2145	66	20	66536	2120							21.5	20.96	20.89		
CA_48A-48A-66A-66A		48	20	56210	3647	1	0	56210	3647	48	20	56640	3690	66	20	66786	2145	66	20	66536	2120							17.5	16.99	16.91		
CA_48A-48A-66B		48	20	56210	3647	1	0	56210	3647	48	20	56640	3690	66	10	67086	2175	66	10	66987	2165.1							17.5	16.99	16.82		
CA_48A-48A-66C		48	20	56210	3647	1	0	56210	3647	48	20	56640	3690	66	20	67036	2170	66	20	66838	2150.2							17.5	16.99	16.73		
CA_48A-66A-66A-66A		48	20	56210	3647	1	0	56210	3647	66	20	67036	2170	66	20	66786	2145	66	20	66536	2120							17.5	16.99	16.88		
CA_2A-2A-46D		2	20	18900																												

## Downlink Carrier Aggregation Scenarios Conducted Power (Laptop)

Configure	Combination	PCC								SCC1				SCC2				SCC3				SCC4				Measurement Power						
		LTE Band	BW [MHz]	UL Channel	UL Freq. [MHz]	UL RB	UL Offset	DL Channel	DL Freq. [MHz]	LTE Band	BW [MHz]	DL Channel	DL Freq. [MHz]	LTE Band	BW [MHz]	DL Channel	DL Freq. [MHz]	LTE Band	BW [MHz]	DL Channel	DL Freq. [MHz]	LTE Band	BW [MHz]	DL Channel	DL Freq. [MHz]	LTE Band	BW [MHz]	DL Channel	DL Freq. [MHz]	Maximum Tune-up Power	Single Carrier Tx Power without DL-CA Active (dBm)	Tx Power with DL-CA Active (dBm)
																		DL Freq. [MHz]													Total	
Inter Band	CA_48A-48C-66B	48	20	56210	3647	1	0	56210	3647	48	20	56442	3670.2	48	20	56640	3690	66	10	67086	2175	66	10	66987	2165.1	17.5	16.99	16.91				
	CA_48A-48C-66C	48	20	56210	3647	1	0	56210	3647	48	20	56442	3670.2	48	20	56640	3690	66	20	67036	2170	66	20	66838	2150.2	17.5	16.99	16.82				
	CA_48A-48D-66A	48	20	56210	3647	1	0	56210	3647	48	20	56244	3650.4	48	20	56442	3670.2	48	20	56640	3690	66	20	67036	2170	17.5	16.99	16.84				
	CA_48C-48C-66A	48	20	56210	3647	1	0	56210	3647	48	20	56408	3666.8	48	20	55340	3560	48	20	55538	3579.8	66	20	67036	2170	17.5	16.99	16.86				
	CA_48C-66A-66A-66A	48	20	56210	3647	1	0	56210	3647	48	20	56408	3666.8	66	20	67036	2170	66	20	66786	2145	66	20	66536	2120	17.5	16.99	16.73				
	CA_48E-66A	48	20	55340	3560	1	0	55340	3560	48	20	55538	3579.8	48	20	55736	3599.6	48	20	55934	3619.4	66	20	67036	2170	17.5	16.81	16.75				
	CA_2A-4A-7A	2	20	18900	1880	1	0	900	1960	4	20	2175	2132.5	7	20	3100	2655											18.0	17.80	17.72		
	CA_2A-4A-13A	2	20	18900	1880	1	0	900	1960	4	20	2175	2132.5	13	10	5230	751											18.0	17.80	17.65		
	CA_2A-5A-46A	2	20	18900	1880	1	0	900	1960	5	10	2450	874	46	20	50665	5537.5											18.0	17.80	17.66		
	CA_2A-13A-46A	2	20	18900	1880	1	0	900	1960	13	10	5230	751	46	20	50665	5537.5											18.0	17.80	17.74		
	CA_2A-29A-30A	2	20	18900	1880	1	0	900	1960	29	10	9715	722.5	30	10	9820	2355											18.0	17.80	17.59		
	CA_2A-46A-48A	2	20	18900	1880	1	0	900	1960	46	20	50665	5537.5	48	20	56210	3647											18.0	17.80	17.62		
	CA_4A-7A-28A	4	20	20175	1732.5	1	0	2175	2132.5	7	20	3100	2655	28	20	9435	780.5											18.0	17.74	17.63		
	CA_4A-29A-30A	4	20	20175	1732.5	1	0	2175	2132.5	29	10	9715	722.5	30	10	9820	2355											18.0	17.74	17.55		
	CA_5A-46A-66A	5	10	20525	836.5	1	0	2525	881.5	46	20	50665	5537.5	66	20	67036	2170										21.5	21.31	21.16			
	CA_13A-46A-66A	13	10	23230	782	1	0	5230	751	46	20	50665	5537.5	66	20	67036	2170										20.0	19.98	19.82			
	CA_2A-2A-4A-5A	2	20	18900	1880	1	0	900	1960	2	20	700	1940	4	20	2175	2132.5	5	10	2450	874						18.0	17.80	17.58			
	CA_2A-2A-4A-12A	2	20	18900	1880	1	0	900	1960	2	20	700	1940	4	20	2175	2132.5	12	10	5094	737.4						18.0	17.80	17.62			
	CA_2A-2A-48C	2	20	18900	1880	1	0	900	1960	2	20	700	1940	46	20	54142	5885.2	46	20	54340	5905						18.0	17.80	17.73			
	CA_2A-4A-4A-5A	2	20	18900	1880	1	0	900	1960	4	20	2050	2120	4	20	2300	2145	5	10	2450	874						18.0	17.80	17.66			
	CA_2A-4A-4A-12A	2	20	18900	1880	1	0	900	1960	4	20	2050	2120	4	20	2300	2145	12	10	5094	737.4						18.0	17.80	17.61			
	CA_2A-4A-5B	2	20	18900	1880	1	0	900	1960	4	20	2175	2132.5	5	10	2450	874	5	10	2549	883.9						18.0	17.80	17.69			
	CA_2A-5A-46C	2	20	18900	1880	1	0	900	1960	5	10	2549	883.9	46	20	54142	5885.2	46	20	54340	5905						18.0	17.80	17.73			
	CA_2A-12A-66C	2	20	18900	1880	1	0	900	1960	12	10	5094	737.4	66	20	67036	2170	66	20	66838	2150.2						18.0	17.80	17.59			
	CA_2A-13A-46C	2	20	18900	1880	1	0	900	1960	13	10	5230	751	46	20	54142	5885.2	46	20	54340	5905						18.0	17.80	17.51			
	CA_2A-13A-66C	2	20	18900	1880	1	0	900	1960	13	10	5230	751	66	20	67036	2170	66	20	66838	2150.2						18.0	17.80	17.65			
	CA_2A-46A-48C	2	20	18900	1880	1	0	900	1960	46	20	46890	5160	48	20	56442	3670.2	48	20	56640	3690						18.0	17.80	17.74			
	CA_2A-46C-48A	2	20	18900	1880	1	0	900	1960	46	20	50665	5537.5	46	20	50863	5557.3	48	20	56210	3647						18.0	17.80	17.63			
	CA_4A-4A-12A-30A	4	20	20300	1745	1	0	2300	2145	4	20	2050	2120	12	10	5094	737.4	30	10	9820	2355						18.0	17.75	17.58			
	CA_5A-46C-66A	5	10	20525	836.5	1	0	2525	881.5	46	20	50665	5537.5	46	20	50863	5557.3	66	20	67036	2170						21.5	21.31	21.14			
	CA_13A-46C-66A	13	10	23230	782	1	0	5230	751	46	20	50665	5537.5	46	20	50863	5557.3	66	20	67036	2170						20	19.98	19.83			
	CA_13A-48A-66B	13	10	23230	782	1	0	5230	751	48	20	56210	3647	66	10	67086	2175	66	10	66987	2165.1						20	19.98	19.88			
	CA_13A-48A-66C	13	10	23230	782	1	0	5230	751	48	20	56210	3647	66	20	67036	2170	66	20	66838	2150.2						20	19.98	19.84			
	CA_2A-2A-5A-66A-66A	2	20	18900	1880	1	0	900	1960	2	20	700	1940	5	10	2450	874	66	20	67036	2170	66	20	66786	2145	18	17.80	17.63				
	CA_2A-2A-5A-66B	2	20	18900	1880	1	0	900	1960	2	20	700	1940	5	10	2450	874	66	10	67086	2175	66	10	66987	2165.1	18	17.80	17.58				
	CA_2A-2A-5A-66C	2	20	18900	1880	1	0	900	1960	2	20	700	1940	5	10	2450	874	66	20	67036	2170	66	20	66838	2150.2	18	17.80	17.51				
	CA_2A-2A-12A-66A-66A	2	20	18900	1880	1	0	900	1960	2	20	700	1940	12	10	5094	737.4	66	20	67036	2170	66	20	66786	2145	18	17.80	17.73				
	CA_2A-2A-13A-66A-66A	2	20	18900	1880	1	0	900	1960	2	20	700	1940	13	10	5230	751	66	20	67036	2170	66	20	66786	2145	18	17.80	17.64				
	CA_2A-2A-13A-66B	2	20	18900	1880	1	0	900	1960	2	20	700	1940	13	10	5230	751	66	10	67086	2175	66	10	66987	2165.1	18	17.80	17.69				
	CA_2A-2A-14A-66A-66A	2	20	18900	1880	1	0	900	1960	2	20	700	1940	14	10	5330	763	66	20	67036	2170	66	20	66786	2145	18	17.80	17.66				
	CA_2A-5A-46D	2	20	18900	1880	1	0	900	1960	5	10	2450	874	46	20	53942	5865.2	46	20	54140	5885	46	20	54338	5904.8	18	17.80	17.55				
	CA_2A-5A-48A-48C	2	20	18900	1880	1	0	900	1960	5	10	2450	874	48	20	56210	3647	48	20	56442	3670.2	48	20	56640	3690	18	17.80	17.64				
	CA_2A-5A-48D	2	20	18900	1880	1	0	900	1960	5	10	2450	874	48	20	56244	3650.4	48	20	56442	3670.2	48	20	56640	3690	18	17.80	17.58				
	CA_2A-5B-66A-66A	2	20	18900	1880	1	0	900	1960	5	10	2450	874	5	10	2549	883.9	66	20	67036	2170	66	20	66786	2145	18	17.80	17.73				
	CA_2A-5B-66B	2	20	18900	1880	1	0	900	1960	5	10	2450	874	5	10	2549	883.9	66	10	67086	2175	66	10	66987	2165.1	18	17.80	17.62				
	CA_2A-5B-66C	2	20	18900	1880	1	0	900	1960	5	10	2450	874	5	10	2549	883.9	66	20	67036	2170	66	20	66838	2150.2	18	17.80	17.64				
	CA_2A-13A-48A-48C	2	20	18900	1880	1	0	900	1960	13	10	5230	751	48	20	56210	3647	48	20	56442	3670.2	48	20	56640	3690	18	17.80	17.71				
	CA_2A-14A-66A-66A-66A	2	20	18900	1880	1	0	900	1960	14	10	5330	763	66	20	67036	2170	66	20	66786	2145	66	20	66536	2120	18	17.80	17.53				
	CA_2A-46A-46C-66A	2	20	18900	1880	1	0	900	1960	46	20	46890	5160	46	20	50692	5540.2	46	20	50892	5560	66	20	67036	2170	18	17.80	17.57				
	CA_2A-46A-48D	2	20	18900	1880	1	0	900	1960	46	20	46890	5160	48	20	56244	3650.4	48	20	56442	3670.2	48	20	56640	3690	18	17.80	17.52				
CA_2A-46C-48C	2	20																														

### Downlink Carrier Aggregation Scenarios Conducted Power (Laptop)

Configure	Combination	PCC								SCC1				SCC2				SCC3				SCC4				Measurement Power		
		LTE Band	BW [Mhz]	UL Channel	UL Freq. [MHz]	UL RB	UL Offset	DL Channel	DL Freq. [MHz]	LTE Band	BW [Mhz]	DL Channel	DL Freq. [MHz]	LTE Band	BW [Mhz]	DL Channel	DL Freq. [MHz]	LTE Band	BW [Mhz]	DL Channel	DL Freq. [MHz]	LTE Band	BW [Mhz]	DL Channel	DL Freq. [MHz]	Maximum Tune-up Power	Single Carrier Tx Power without DL-CA Active (dBm)	Tx Power with DL-CA Active (dBm)
	CA_2A-13A-48D	2	20	18900	1880	1	0	900	1960	13	10	5230	751	48	20	56244	3650.4	48	20	56442	3670.2	48	20	56640	3690	18	17.80	17.73
	CA_5A-48A-48C-66A	5	10	20525	836.5	1	0	2525	881.5	48	20	56210	3647	48	20	56442	3670.2	48	20	56640	3690	66	20	67036	2170	21.5	21.31	21.21
	CA_13A-48A-48C-66A	13	10	23230	782	1	0	5230	751	48	20	56210	3647	48	20	56442	3670.2	48	20	56640	3690	66	20	67036	2170	20	19.98	19.92
	CA_2A-4A-5A-30A	2	20	18900	1880	1	0	900	1960	4	20	2175	2132.5	5	10	2450	874	30	10	9820	2355					18	17.80	17.73
	CA_2A-4A-12A-30A	2	20	18900	1880	1	0	900	1960	4	20	2175	2132.5	12	10	5094	737.4	30	10	9820	2355					18	17.80	17.77
	CA_2A-5A-30A-66A	2	20	18900	1880	1	0	900	1960	5	10	2450	874	30	10	9820	2355	66	20	67036	2170					18	17.80	17.58
	CA_2A-5A-48A-48A-66A	2	20	18900	1880	1	0	900	1960	5	10	2450	874	48	20	55780	3603	48	20	56640	3690	66	20	67036	2170	18	17.80	17.65
	CA_2A-5B-30A-66A	2	20	18900	1880	1	0	900	1960	5	10	2450	874	5	10	2549	883.9	30	10	9820	2355	66	20	67036	2170	18	17.80	17.69
	CA_2A-12A-30A-66A-66A	2	20	18900	1880	1	0	900	1960	12	10	5094	737.4	30	10	9820	2355	66	20	67036	2170	66	20	66786	2145	18	17.80	17.51
	CA_2A-13A-48A-48A-66A	2	20	18900	1880	1	0	900	1960	13	10	5230	751	48	20	56210	3647	48	20	56012	3627.2	66	20	67036	2170	18	17.80	17.72
	CA_2A-13A-48C-66A	2	20	18900	1880	1	0	900	1960	13	10	5230	751	48	20	56442	3670.2	48	20	56640	3690	66	20	67036	2170	18	17.80	17.66
	CA_2A-14A-30A-66A-66A	2	20	18900	1880	1	0	900	1960	14	10	5330	763	30	10	9820	2355	66	20	67036	2170	66	20	66786	2145	18	17.80	17.64
	CA_2A-5A-48C-66A	2	20	18900	1880	1	0	900	1960	5	10	2450	874	48	20	56442	3670.2	48	20	56640	3690	66	20	67036	2170	18	17.80	17.69

WLAN Conducted Power (Laptop)			
WLAN2.4GHz Ant 0			
Mode	Channel	Frequency	SISO Ant 0 Avg. Power
802.11b	1	2412	19.95
	6	2437	19.96
	11	2462	19.89
	12	2467	18.69
	13	2472	15.67
802.11g	1	2412	19.37
	6	2437	19.95
	11	2462	17.89
	12	2467	14.95
	13	2472	11.69
802.11n HT20	1	2412	19.42
	6	2437	19.93
	11	2462	17.95
	12	2467	14.91
	13	2472	11.62
802.11n HT40	3	2422	15.36
	6	2437	17.39
	9	2452	15.37
	10	2457	12.16
	11	2462	9.63
802.11ax HE20	1	2412	19.43
	6	2437	19.88
	11	2462	17.92
	12	2467	14.89
	13	2472	11.62
802.11ax HE40	3	2422	15.39
	6	2437	17.37
	9	2452	15.45
	10	2457	12.11
	11	2462	9.65

WLAN Conducted Power (Laptop)			
WLAN2.4GHz Ant 1			
Mode	Channel	Frequency	SISO Ant 1 Avg. Power
802.11b	1	2412	19.93
	6	2437	19.96
	11	2462	19.92
	12	2467	19.22
	13	2472	16.68
802.11g	1	2412	19.16
	6	2437	19.91
	11	2462	18.16
	12	2467	14.67
	13	2472	11.95
802.11n HT20	1	2412	19.22
	6	2437	19.93
	11	2462	18.21
	12	2467	14.67
	13	2472	11.92
802.11n HT40	3	2422	15.72
	6	2437	17.61
	9	2452	16.93
	10	2457	12.36
	11	2462	10.72
802.11ax HE20	1	2412	19.16
	6	2437	19.91
	11	2462	18.16
	12	2467	14.63
	13	2472	11.95
802.11ax HE40	3	2422	15.62
	6	2437	17.65
	9	2452	16.88
	10	2457	12.36
	11	2462	10.62

WLAN Conducted Power (Laptop)					
WLAN2.4GHz Ant 0+1					
Mode	Channel	Frequency	MIMO Ant 0 Avg. Power	MIMO Ant 1 Avg. Power	MIMO Ant 0+1 Avg. Power
802.11b	1	2412			
	6	2437			
	11	2462			
	12	2467			
	13	2472			
802.11g	1	2412			
	6	2437			
	11	2462			
	12	2467			
	13	2472			
802.11n HT20	1	2412	16.43	16.45	19.45
	6	2437	19.93	19.95	22.95
	11	2462	16.48	16.47	19.49
	12	2467	11.22	11.23	14.24
	13	2472	8.48	8.43	11.47
802.11n HT40	3	2422	15.12	15.12	18.13
	6	2437	15.91	15.89	18.91
	9	2452	15.41	15.43	18.43
	10	2457	11.2	11.18	14.20
	11	2462	8.16	8.17	11.18
802.11ax HE20	1	2412	14.45	14.4	17.44
	6	2437	17.77	17.73	20.76
	11	2462	14.36	14.43	17.41
	12	2467	11.11	11.18	14.16
	13	2472	8.38	8.38	11.39
802.11ax HE40	3	2422	13.38	13.45	16.43
	6	2437	13.72	13.68	16.71
	9	2452	12.66	12.61	15.65
	10	2457	11.11	11.12	14.13
	11	2462	8.15	8.17	11.17

WLAN Conducted Power (Laptop)			
Bluetooth Ant 1			
Mode	Channel	Frequency	SISO Ant 1 Avg. Power
BR / EDR	0	2402	9.03
	39	2441	9.25
	78	2480	9.68
LE	0	2402	6.71
	19	2440	6.87
	39	2480	6.98

WLAN Conducted Power (Laptop)			
WLAN 5.3GHz Ant 0			
Mode	Channel	Frequency	SISO Ant 0 Avg. Power
802.11a	52	5260	19.85
	56	5280	19.95
	60	5300	19.98
	64	5320	19.96
802.11n HT20	52	5260	19.61
	56	5280	19.89
	60	5300	19.91
	64	5320	19.88
802.11n HT40	54	5270	19.75
	62	5310	17.41
802.11ac VHT80	58	5290	17.43
802.11ac VHT160	50	5250	14.38
802.11ax HE20	52	5260	19.79
	56	5280	19.89
	60	5300	19.86
	64	5320	19.93
802.11ax HE40	54	5270	19.62
	62	5310	17.43
802.11ax HE80	58	5290	17.44
802.11ax HE160	50	5250	14.41



WLAN Conducted Power (Laptop)			
WLAN 5.3GHz Ant 1			
Mode	Channel	Frequency	SISO Ant 1 Avg. Power
802.11a	52	5260	19.91
	56	5280	19.92
	60	5300	19.87
	64	5320	19.88
802.11n HT20	52	5260	19.85
	56	5280	19.85
	60	5300	19.85
	64	5320	19.87
802.11n HT40	54	5270	19.98
	62	5310	17.48
802.11ac VHT80	58	5290	17.39
802.11ac VHT160	50	5250	13.86
802.11ax HE20	52	5260	19.93
	56	5280	19.91
	60	5300	19.93
	64	5320	19.88
802.11ax HE40	54	5270	19.92
	62	5310	17.41
802.11ax HE80	58	5290	17.39
802.11ax HE160	50	5250	13.86

WLAN Conducted Power (Laptop)					
WLAN 5.3GHz Ant 0+1					
Mode	Channel	Frequency	MIMO Ant 0 Avg. Power	MIMO Ant 1 Avg. Power	MIMO Ant 0+1 Avg. Power
802.11a	52	5260			
	56	5280			
	60	5300			
	64	5320			
802.11n HT20	52	5260	17.93	17.87	20.91
	56	5280	17.91	17.91	20.92
	60	5300	17.93	17.95	20.95
	64	5320	17.42	17.37	20.41
802.11n HT40	54	5270	19.97	19.95	22.97
	62	5310	16.48	16.43	19.47
802.11ac VHT80	58	5290	14.16	14.11	17.15
802.11ac VHT160	50	5250	12.45	12.43	15.45
802.11ax HE20	52	5260	18.13	18.11	21.13
	56	5280	17.88	17.92	20.91
	60	5300	18.27	18.28	21.29
	64	5320	15.62	15.62	18.63
802.11ax HE40	54	5270	18.68	18.65	21.68
	62	5310	14.17	14.18	17.19
802.11ax HE80	58	5290	14.17	14.15	17.17
802.11ax HE160	50	5250	12.41	12.43	15.43

WLAN Conducted Power (Laptop)			
WLAN 5.6GHz Ant 0			
Mode	Channel	Frequency	SISO Ant 0 Avg. Power
802.11a	100	5500	19.92
	116	5580	19.86
	120	5600	19.95
	124	5620	19.93
	132	5660	19.91
	140	5700	19.89
	144	5720	19.88
802.11n HT20	100	5500	19.92
	116	5580	19.94
	120	5600	19.86
	124	5620	19.89
	132	5660	19.92
	140	5700	19.93
	144	5720	19.92
802.11n HT40	102	5510	19.61
	110	5550	19.85
	118	5590	19.95
	126	5630	19.88
	134	5670	19.93
	142	5710	19.87
802.11ac VHT80	106	5530	18.47
	122	5610	19.96
	138	5690	19.98
802.11ac VHT160	114	5570	15.35
802.11ax HE20	100	5500	19.91
	116	5580	19.95
	120	5600	19.85
	124	5620	19.88
	132	5660	19.86
	140	5700	19.89
	144	5720	19.89
802.11ax HE40	102	5510	19.66
	110	5550	19.91
	118	5590	19.88
	126	5630	19.85
	134	5670	19.93
	142	5710	19.88
802.11ax HE80	106	5530	18.36
	122	5610	19.88
	138	5690	19.88
802.11ax HE160	114	5570	15.45

WLAN Conducted Power (Laptop)			
WLAN 5.6GHz Ant 1			
Mode	Channel	Frequency	SISO Ant 1 Avg. Power
802.11a	100	5500	19.92
	116	5580	19.95
	120	5600	19.93
	124	5620	19.91
	132	5660	19.92
	140	5700	19.92
	144	5720	19.87
802.11n HT20	100	5500	19.93
	116	5580	19.95
	120	5600	19.93
	124	5620	19.92
	132	5660	19.95
	140	5700	19.88
	144	5720	19.86
802.11n HT40	102	5510	19.88
	110	5550	19.87
	118	5590	19.94
	126	5630	19.87
	134	5670	19.91
	142	5710	19.89
802.11ac VHT80	106	5530	18.72
	122	5610	19.95
	138	5690	19.98
802.11ac VHT160	114	5570	15.35
802.11ax HE20	100	5500	19.95
	116	5580	19.86
	120	5600	19.91
	124	5620	19.92
	132	5660	19.91
	140	5700	19.89
	144	5720	19.92
802.11ax HE40	102	5510	19.93
	110	5550	19.91
	118	5590	19.87
	126	5630	19.93
	134	5670	19.87
	142	5710	19.91
802.11ax HE80	106	5530	18.62
	122	5610	19.93
	138	5690	19.88
802.11ax HE160	114	5570	15.39

WLAN Conducted Power (Laptop)					
WLAN 5.6GHz Ant 0+1					
Mode	Channel	Frequency	MIMO Ant 0 Avg. Power	MIMO Ant 1 Avg. Power	MIMO Ant 0+1 Avg. Power
802.11a	100	5500			
	116	5580			
	120	5600			
	124	5620			
	132	5660			
	140	5700			
	144	5720			
802.11n HT20	100	5500	18.37	18.42	21.41
	116	5580	18.42	18.37	21.41
	120	5600	18.39	18.42	21.42
	124	5620	18.43	18.37	21.41
	132	5660	18.45	18.37	21.42
	140	5700	18.42	18.42	21.43
	144	5720	16.92	16.91	19.93
802.11n HT40	102	5510	17.21	17.23	20.23
	110	5550	17.98	17.95	20.98
	118	5590	17.95	17.92	20.95
	126	5630	17.93	17.88	20.92
	134	5670	19.42	19.45	22.45
	142	5710	16.93	16.96	19.96
802.11ac VHT80	106	5530	14.72	14.65	17.7
	122	5610	17.28	17.28	20.29
	138	5690	17.12	17.15	20.15
802.11ac VHT160	114	5570	13.93	13.91	16.93
802.11ax HE20	100	5500	16.66	16.67	19.68
	116	5580	18.19	18.11	21.16
	120	5600	18.16	18.12	21.15
	124	5620	18.17	18.19	21.19
	132	5660	18.16	18.13	21.16
	140	5700	16.69	16.67	19.69
	144	5720	16.12	16.21	19.18
802.11ax HE40	102	5510	17.13	17.23	20.19
	110	5550	17.75	17.73	20.75
	118	5590	17.76	17.76	20.77
	126	5630	17.77	17.81	20.8
	134	5670	17.89	17.93	20.92
	142	5710	16.72	16.78	19.76
802.11ax HE80	106	5530	14.65	14.69	17.68
	122	5610	17.78	17.75	20.78
	138	5690	17.22	17.12	20.18
802.11ax HE160	114	5570	13.95	13.92	16.95

WLAN Conducted Power (Laptop)			
WLAN 5.8GHz Ant 0			
Mode	Channel	Frequency	SISO Ant 0 Avg. Power
802.11a	149	5745	19.95
	153	5765	19.88
	157	5785	19.92
	161	5805	19.91
	165	5825	19.86
802.11n HT20	149	5745	19.88
	153	5765	19.87
	157	5785	19.91
	161	5805	19.85
	165	5825	19.92
802.11n HT40	151	5755	19.93
	159	5795	19.93
802.11ac VHT80	155	5775	19.98
802.11ax HE20	149	5745	19.95
	153	5765	19.87
	157	5785	19.92
	161	5805	19.95
	165	5825	19.89
802.11ax HE40	151	5755	19.88
	159	5795	19.92
802.11ax HE80	155	5775	19.95

WLAN Conducted Power (Laptop)			
WLAN 5.8GHz Ant 1			
Mode	Channel	Frequency	SISO Ant 1 Avg. Power
802.11a	149	5745	19.85
	153	5765	19.88
	157	5785	19.91
	161	5805	19.88
	165	5825	19.87
802.11n HT20	149	5745	19.88
	153	5765	19.93
	157	5785	19.92
	161	5805	19.85
	165	5825	19.89
802.11n HT40	151	5755	19.92
	159	5795	19.86
802.11ac VHT80	155	5775	19.95
802.11ax HE20	149	5745	19.91
	153	5765	19.92
	157	5785	19.88
	161	5805	19.88
	165	5825	19.86
802.11ax HE40	151	5755	19.89
	159	5795	19.88
802.11ax HE80	155	5775	19.93

WLAN Conducted Power (Laptop)					
WLAN 5.8GHz Ant 0+1					
Mode	Channel	Frequency	MIMO Ant 0 Avg. Power	MIMO Ant 1 Avg. Power	MIMO Ant 0+1 Avg. Power
802.11a	149	5745			
	153	5765			
	157	5785			
	161	5805			
	165	5825			
802.11n HT20	149	5745	19.92	19.87	22.91
	153	5765	19.85	19.95	22.91
	157	5785	19.89	19.85	22.88
	161	5805	19.87	19.95	22.92
	165	5825	19.87	19.93	22.91
802.11n HT40	151	5755	19.98	19.93	22.97
	159	5795	19.97	19.91	22.95
802.11ac VHT80	155	5775	15.65	15.62	18.65
802.11ax HE20	149	5745	18.07	18.07	21.08
	153	5765	17.97	18.06	21.03
	157	5785	18.05	18.12	21.1
	161	5805	18.08	18.08	21.09
	165	5825	18.11	18.13	21.13
802.11ax HE40	151	5755	18.49	18.57	21.54
	159	5795	18.57	18.55	21.57
802.11ax HE80	155	5775	15.72	15.63	18.69



WLAN Conducted Power (Laptop)			
UNII-5 Ant 0			
Mode	Channel	Frequency	SISO Ant 0 Avg. Power
802.11ax HE20	1	5955	4.86
	5	5975	4.91
	9	5995	4.95
	13	6015	4.91
	17	6035	4.88
	21	6055	4.87
	25	6075	4.93
	29	6095	4.89
	33	6115	4.95
	37	6135	4.93
	41	6155	4.86
	45	6175	4.89
	49	6195	4.85
	53	6215	4.87
	57	6235	4.89
	61	6255	4.92
	65	6275	4.95
	69	6295	4.91
	73	6315	4.92
	77	6335	4.93
802.11ax HE40	81	6355	4.87
	85	6375	4.95
	89	6395	4.88
	93	6415	4.94
	3	5965	8.16
	11	6005	8.15
	19	6045	8.13
	27	6085	8.15
	35	6125	8.21
	43	6165	8.15
	51	6205	8.18
	59	6245	8.17
802.11ax HE80	67	6285	8.11
	75	6325	8.18
	83	6365	8.15
	91	6405	8.11
	7	5985	10.61
	23	6065	10.63
802.11ax HE160	39	6145	10.62
	55	6225	10.64
	71	6305	10.61
802.11ax HE160	87	6385	10.6
	15	6025	12.98
	47	6185	12.93
	79	6345	12.97

WLAN Conducted Power (Laptop)			
UNII-5 Ant 1			
Mode	Channel	Frequency	SISO Ant 1 Avg. Power
802.11ax HE20	1	5955	4.87
	5	5975	4.91
	9	5995	4.87
	13	6015	4.93
	17	6035	4.86
	21	6055	4.97
	25	6075	4.85
	29	6095	4.95
	33	6115	4.93
	37	6135	4.92
	41	6155	4.91
	45	6175	4.93
	49	6195	4.91
	53	6215	4.95
	57	6235	4.93
	61	6255	4.88
	65	6275	4.92
	69	6295	4.93
	73	6315	4.95
	77	6335	4.87
81	6355	4.88	
85	6375	4.91	
89	6395	4.95	
93	6415	4.88	
802.11ax HE40	3	5965	8.18
	11	6005	8.21
	19	6045	8.16
	27	6085	8.17
	35	6125	8.12
	43	6165	8.18
	51	6205	8.16
	59	6245	8.11
	67	6285	8.19
	75	6325	8.12
	83	6365	8.15
91	6405	8.17	
802.11ax HE80	7	5985	10.65
	23	6065	10.67
	39	6145	10.63
	55	6225	10.65
	71	6305	10.62
	87	6385	10.65
802.11ax HE160	15	6025	12.97
	47	6185	12.95
	79	6345	12.96

WLAN Conducted Power (Laptop)					
UNII-5 Ant 0+1					
Mode	Channel	Frequency	MIMO Ant 0 Avg. Power	MIMO Ant 1 Avg. Power	MIMO Ant 0+1 Avg. Power
802.11ax HE20	1	5955	1.87	1.95	4.92
	5	5975	1.88	1.87	4.89
	9	5995	1.92	1.91	4.93
	13	6015	1.91	1.88	4.91
	17	6035	1.93	1.95	4.95
	21	6055	1.92	1.88	4.91
	25	6075	1.92	1.91	4.93
	29	6095	1.86	1.87	4.88
	33	6115	1.85	1.98	4.93
	37	6135	1.93	1.95	4.95
	41	6155	1.88	1.87	4.89
	45	6175	1.91	1.89	4.91
	49	6195	1.93	1.91	4.93
	53	6215	1.92	1.89	4.92
	57	6235	1.89	1.87	4.89
	61	6255	1.95	1.88	4.93
	65	6275	1.89	1.86	4.89
	69	6295	1.88	1.93	4.92
	73	6315	1.85	1.85	4.86
	77	6335	1.89	1.92	4.92
81	6355	1.87	1.93	4.91	
85	6375	1.91	1.97	4.95	
89	6395	1.96	1.86	4.92	
93	6415	1.88	1.88	4.89	
802.11ax HE40	3	5965	5.11	5.13	8.13
	11	6005	5.11	5.17	8.15
	19	6045	5.17	5.18	8.19
	27	6085	5.16	5.12	8.15
	35	6125	5.11	5.13	8.13
	43	6165	5.18	5.23	8.22
	51	6205	5.13	5.18	8.17
	59	6245	5.22	5.13	8.19
	67	6285	5.19	5.22	8.22
	75	6325	5.16	5.16	8.17
	83	6365	5.17	5.18	8.19
91	6405	5.13	5.17	8.16	
802.11ax HE80	7	5985	7.65	7.67	10.67
	23	6065	7.61	7.66	10.65
	39	6145	7.65	7.63	10.65
	55	6225	7.68	7.69	10.7
	71	6305	7.63	7.61	10.63
	87	6385	7.62	7.61	10.63
802.11ax HE160	15	6025	10.47	10.42	13.46
	47	6185	10.43	10.41	13.43
	79	6345	10.45	10.43	13.45

WLAN Conducted Power (Laptop)			
UNII-6 Ant 0			
Mode	Channel	Frequency	SISO Ant 0 Avg. Power
802.11ax HE20	97	6435	4.87
	101	6455	4.91
	105	6475	4.89
	109	6495	4.92
	113	6515	4.95
	117	6535	4.23
802.11ax HE40	99	6445	8.13
	107	6485	8.16
	115	6525	8.11
802.11ax HE80	103	6465	10.69
	119	6545	10.67
802.11ax HE160	111	6505	12.98

WLAN Conducted Power (Laptop)			
UNII-6 Ant 1			
Mode	Channel	Frequency	SISO Ant 1 Avg. Power
802.11ax HE20	97	6435	4.96
	101	6455	4.93
	105	6475	4.89
	109	6495	4.95
	113	6515	4.88
	117	6535	4.17
802.11ax HE40	99	6445	8.18
	107	6485	8.17
	115	6525	8.15
802.11ax HE80	103	6465	10.67
	119	6545	10.61
802.11ax HE160	111	6505	12.95

WLAN Conducted Power (Laptop)					
UNII-6 Ant 0+1					
Mode	Channel	Frequency	MIMO Ant 0 Avg. Power	MIMO Ant 1 Avg. Power	MIMO Ant 0+1 Avg. Power
802.11ax HE20	97	6435	1.91	1.92	4.93
	101	6455	1.87	1.88	4.89
	105	6475	1.89	1.87	4.89
	109	6495	1.93	1.95	4.95
	113	6515	1.95	1.88	4.93
	117	6535	1.11	1.11	4.12
802.11ax HE40	99	6445	5.13	5.19	8.17
	107	6485	5.18	5.15	8.18
	115	6525	5.11	5.11	8.12
802.11ax HE80	103	6465	7.67	7.68	10.69
	119	6545	7.65	7.68	10.68
802.11ax HE160	111	6505	10.48	10.47	13.49

WLAN Conducted Power (Laptop)			
UNII-7 Ant 0			
Mode	Channel	Frequency	SISO Ant 0 Avg. Power
802.11ax HE20	121	6555	3.9
	125	6575	3.97
	129	6595	3.9
	133	6615	3.97
	137	6635	4.03
	141	6655	3.97
	145	6675	4.06
	149	6695	4.05
	153	6715	3.96
	157	6735	4.07
	161	6755	3.94
	165	6775	3.95
	169	6795	3.98
	173	6815	4.01
	177	6835	3.97
	181	6855	4.09
185	6875	4.01	
802.11ax HE40	123	6565	7.29
	131	6605	7.2
	139	6645	7.35
	147	6685	7.35
	155	6725	7.33
	163	6765	7.29
	171	6805	7.22
	179	6845	7.28
187	6885	7.21	
802.11ax HE80	135	6625	9.75
	151	6705	9.72
	167	6785	9.8
	183	6865	9.72
802.11ax HE160	143	6665	12.72
	175	6825	12.69

WLAN Conducted Power (Laptop)			
UNII-7 Ant 1			
Mode	Channel	Frequency	SISO Ant 1 Avg. Power
802.11ax HE20	121	6555	4.07
	125	6575	4.06
	129	6595	3.93
	133	6615	4.01
	137	6635	4.04
	141	6655	3.9
	145	6675	3.97
	149	6695	3.98
	153	6715	3.98
	157	6735	4.04
	161	6755	4.09
	165	6775	4.04
	169	6795	4.02
	173	6815	3.95
	177	6835	4.02
	181	6855	4.1
185	6875	3.95	
802.11ax HE40	123	6565	7.35
	131	6605	7.18
	139	6645	7.23
	147	6685	7.2
	155	6725	7.25
	163	6765	7.2
	171	6805	7.32
	179	6845	7.29
187	6885	7.32	
802.11ax HE80	135	6625	9.82
	151	6705	9.82
	167	6785	9.85
	183	6865	9.82
802.11ax HE160	143	6665	12.71
	175	6825	12.69



WLAN Conducted Power (Laptop)					
UNII-7 Ant 0+1					
Mode	Channel	Frequency	MIMO Ant 0 Avg. Power	MIMO Ant 1 Avg. Power	MIMO Ant 0+1 Avg. Power
802.11ax HE20	121	6555	0.91	0.94	3.94
	125	6575	1.03	1	4.03
	129	6595	0.99	0.93	3.97
	133	6615	1.06	1.04	4.06
	137	6635	0.93	1.07	4.01
	141	6655	1.02	1.08	4.06
	145	6675	1.08	1.09	4.1
	149	6695	1.03	0.99	4.02
	153	6715	0.95	0.94	3.96
	157	6735	1	0.95	3.99
	161	6755	1.03	1.04	4.05
	165	6775	1	1.07	4.05
	169	6795	0.94	0.9	3.93
	173	6815	0.96	1.07	4.03
	177	6835	0.92	0.95	3.95
	181	6855	0.97	1.05	4.02
185	6875	1.04	0.98	4.02	
802.11ax HE40	123	6565	4.28	4.24	7.27
	131	6605	4.31	4.28	7.31
	139	6645	4.15	4.28	7.23
	147	6685	4.32	4.16	7.25
	155	6725	4.2	4.17	7.2
	163	6765	4.22	4.24	7.24
	171	6805	4.2	4.35	7.29
	179	6845	4.3	4.31	7.32
802.11ax HE80	187	6885	4.15	4.33	7.25
	135	6625	6.83	6.81	9.83
	151	6705	6.67	6.76	9.73
	167	6785	6.66	6.67	9.68
802.11ax HE160	183	6865	6.74	6.82	9.79
	143	6665	9.58	9.58	12.59
	175	6825	9.67	9.6	12.65

WLAN Conducted Power (Laptop)			
UNII-8 Ant 0			
Mode	Channel	Frequency	SISO Ant 0 Avg. Power
802.11ax HE20	189	6895	3.96
	193	6915	4.04
	197	6935	3.95
	201	6955	4.09
	205	6975	4.07
	209	6995	4.08
	213	7015	3.92
	217	7035	3.98
	221	7055	3.98
	225	7075	4.03
	229	7095	4.1
	233	7115	-1.31
802.11ax HE40	195	6925	7.28
	203	6965	7.31
	211	7005	7.18
	219	7045	7.31
	227	7085	7.3
802.11ax HE80	199	6945	9.65
	215	7025	9.66
802.11ax HE160	207	6985	12.63

WLAN Conducted Power (Laptop)			
UNII-8 Ant 1			
Mode	Channel	Frequency	SISO Ant 1 Avg. Power
802.11ax HE20	189	6895	4.07
	193	6915	4.09
	197	6935	4.03
	201	6955	3.99
	205	6975	4.02
	209	6995	4.07
	213	7015	3.9
	217	7035	4.02
	221	7055	4.08
	225	7075	4.02
	229	7095	4.08
	233	7115	-1.23
802.11ax HE40	195	6925	7.32
	203	6965	7.21
	211	7005	7.2
	219	7045	7.25
	227	7085	7.21
802.11ax HE80	199	6945	9.84
	215	7025	9.7
802.11ax HE160	207	6985	12.71

WLAN Conducted Power (Laptop)					
UNII-8 Ant 0+1					
Mode	Channel	Frequency	MIMO Ant 0 Avg. Power	MIMO Ant 1 Avg. Power	MIMO Ant 0+1 Avg. Power
802.11ax HE20	189	6895	0.95	1.07	4.02
	193	6915	0.9	0.97	3.95
	197	6935	0.92	1.08	4.01
	201	6955	0.91	0.97	3.95
	205	6975	1.09	0.9	4.01
	209	6995	0.93	0.93	3.94
	213	7015	1.07	1.1	4.1
	217	7035	1.1	0.93	4.03
	221	7055	0.96	1.05	4.02
	225	7075	0.98	1.04	4.02
	229	7095	1.05	1.05	4.06
	233	7115	-4.29	-4.42	-1.34
802.11ax HE40	195	6925	4.25	4.19	7.23
	203	6965	4.17	4.18	7.19
	211	7005	4.26	4.32	7.3
	219	7045	4.25	4.16	7.22
	227	7085	4.24	4.3	7.28
802.11ax HE80	199	6945	6.65	6.77	9.72
	215	7025	6.84	6.83	9.85
802.11ax HE160	207	6985	9.71	9.64	12.69

## **Annex F. SAR Test Result**

SAR Results for Body Exposure Condition.

### **Note:**

1. SAR testing for WLAN was performed on the maximum power mode.
2. SAR testing for LTE / NR was performed on the maximum power mode.
3. The “< 0.001” means there is no SAR value or the SAR is too low to be measured.

### Laptop SAR Test Result

System & Position								DUT & Accessory				SAR					
Plot No.	Band	Mode	Test Position	Separation Distance (mm)	Channel	RB#	RB offset	Ant Status	Power Reduction	Duty Cycle	Crest Factor	Max. Tune-up Power (dBm)	Measured Conducted Power (dBm)	Scaling Factor	Power Drift (dB)	Measured SAR-1g (W/kg)	Scaled SAR-1g (W/kg)
1	WCDMA II	RMC12.2K	Bottom for Laptop	0	9400			Ant 0	w/	-	1.00	17.50	16.98	1.13	-0.05	0.579	0.65
	WCDMA II	RMC12.2K	Bottom for Laptop	0	9262			Ant 0	w/	-	1.00	17.50	16.90	1.15	0.04	0.557	0.64
	WCDMA II	RMC12.2K	Bottom for Laptop	0	9538			Ant 0	w/	-	1.00	17.50	16.88	1.15	-0.12	0.554	0.64
	WCDMA II	RMC12.2K	Lid Closed for Laptop	0	9400			Ant 0	w/	-	1.00	17.50	16.98	1.13	-0.01	0.271	0.31
2	WCDMA IV	RMC12.2K	Bottom for Laptop	0	1312			Ant 0	w/	-	1.00	18.50	17.65	1.22	-0.02	0.473	0.58
	WCDMA IV	RMC12.2K	Bottom for Laptop	0	1413			Ant 0	w/	-	1.00	18.50	17.63	1.22	-0.1	0.45	0.55
	WCDMA IV	RMC12.2K	Bottom for Laptop	0	1513			Ant 0	w/	-	1.00	18.50	17.60	1.23	-0.15	0.463	0.57
	WCDMA IV	RMC12.2K	Lid Closed for Laptop	0	1312			Ant 0	w/	-	1.00	18.50	17.65	1.22	0.01	0.23	0.28
3	WCDMA V	RMC12.2K	Bottom for Laptop	0	4132			Ant 0	w/	-	1.00	22.50	21.98	1.13	-0.04	0.236	0.27
	WCDMA V	RMC12.2K	Bottom for Laptop	0	4182			Ant 0	w/	-	1.00	22.50	21.90	1.15	0.16	0.229	0.26
	WCDMA V	RMC12.2K	Bottom for Laptop	0	4233			Ant 0	w/	-	1.00	22.50	21.92	1.14	-0.12	0.23	0.26
	WCDMA V	RMC12.2K	Lid Closed for Laptop	0	4132			Ant 0	w/	-	1.00	22.50	21.98	1.13	-0.15	0.146	0.16
4	LTE 2	QPSK20M	Bottom for Laptop	0	18700	1	0	Ant 0	w/	-	1.00	18.00	17.85	1.04	-0.1	0.626	0.65
	LTE 2	QPSK20M	Bottom for Laptop	0	18700	50	0	Ant 0	w/	-	1.00	17.00	16.84	1.04	0.09	0.514	0.53
	LTE 2	QPSK20M	Bottom for Laptop	0	18900	1	0	Ant 0	w/	-	1.00	18.00	17.80	1.05	-0.11	0.614	0.64
	LTE 2	QPSK20M	Bottom for Laptop	0	19100	1	0	Ant 0	w/	-	1.00	18.00	17.81	1.04	-0.04	0.603	0.63
	LTE 2	QPSK20M	Lid Closed for Laptop	0	18700	1	0	Ant 0	w/	-	1.00	18.00	17.85	1.04	0.15	0.32	0.33
5	LTE 4	QPSK20M	Bottom for Laptop	0	20050	1	0	Ant 0	w/	-	1.00	18.00	17.81	1.04	-0.05	0.629	0.65
	LTE 4	QPSK20M	Bottom for Laptop	0	20050	50	0	Ant 0	w/	-	1.00	17.00	16.57	1.10	0.11	0.481	0.53
	LTE 4	QPSK20M	Bottom for Laptop	0	20175	1	0	Ant 0	w/	-	1.00	18.00	17.74	1.06	-0.06	0.603	0.64
	LTE 4	QPSK20M	Bottom for Laptop	0	20300	1	0	Ant 0	w/	-	1.00	18.00	17.75	1.06	-0.08	0.614	0.65
	LTE 4	QPSK20M	Lid Closed for Laptop	0	20050	1	0	Ant 0	w/	-	1.00	18.00	17.81	1.04	-0.14	0.282	0.29
6	LTE 5	QPSK10M	Bottom for Laptop	0	20525	1	0	Ant 0	w/	-	1.00	21.50	21.31	1.04	-0.03	0.511	0.53
	LTE 5	QPSK10M	Bottom for Laptop	0	20525	25	0	Ant 0	w/	-	1.00	20.50	20.47	1.01	0.05	0.398	0.40
	LTE 5	QPSK10M	Bottom for Laptop	0	20450	1	0	Ant 0	w/	-	1.00	21.50	21.30	1.05	0.02	0.49	0.51
	LTE 5	QPSK10M	Bottom for Laptop	0	20600	1	0	Ant 0	w/	-	1.00	21.50	21.12	1.09	0.14	0.465	0.51
	LTE 5	QPSK10M	Bottom for Laptop	0	PCC : 20450 SCC : 20549	PCC : 1 SCC : 1	PCC : 0 SCC : 49	Ant 0	w/	-	1.00	21.50	21.21	1.07	0.04	0.419	0.45
	LTE 5	QPSK10M	Lid Closed for Laptop	0	20525	1	0	Ant 0	w/	-	1.00	21.50	21.31	1.04	0.16	0.388	0.40
7	LTE 7	QPSK20M	Bottom for Laptop	0	21350	1	0	Ant 0	w/	-	1.00	18.00	17.86	1.03	-0.11	0.579	0.60
	LTE 7	QPSK20M	Bottom for Laptop	0	21350	50	0	Ant 0	w/	-	1.00	17.00	16.44	1.14	-0.09	0.491	0.56
	LTE 7	QPSK20M	Bottom for Laptop	0	20850	1	0	Ant 0	w/	-	1.00	18.00	17.82	1.04	0.14	0.565	0.59
	LTE 7	QPSK20M	Bottom for Laptop	0	21100	1	0	Ant 0	w/	-	1.00	18.00	17.66	1.08	0.03	0.539	0.58
	LTE 7	QPSK20M	Bottom for Laptop	0	PCC : 21152 SCC : 21350	PCC : 1 SCC : 1	PCC : 0 SCC : 99	Ant 0	w/	-	1.00	18.00	17.74	1.06	-0.16	0.436	0.46
	LTE 7	QPSK20M	Lid Closed for Laptop	0	21350	1	0	Ant 0	w/	-	1.00	18.00	17.86	1.03	-0.19	0.461	0.47
8	LTE 12	QPSK10M	Bottom for Laptop	0	23130	1	0	Ant 0	w/	-	1.00	19.50	19.35	1.04	0.03	0.559	0.58
	LTE 12	QPSK10M	Bottom for Laptop	0	23130	25	0	Ant 0	w/	-	1.00	18.50	18.06	1.11	0.12	0.441	0.49
	LTE 12	QPSK10M	Bottom for Laptop	0	23060	1	0	Ant 0	w/	-	1.00	19.50	19.29	1.05	0.19	0.549	0.58
	LTE 12	QPSK10M	Bottom for Laptop	0	23095	1	0	Ant 0	w/	-	1.00	19.50	19.33	1.04	0.08	0.535	0.56
	LTE 12	QPSK10M	Lid Closed for Laptop	0	23130	1	0	Ant 0	w/	-	1.00	19.50	19.35	1.04	0.12	0.346	0.36
9	LTE 13	QPSK10M	Bottom for Laptop	0	23230	1	0	Ant 0	w/	-	1.00	20.00	19.98	1.00	0.07	0.52	0.52
	LTE 13	QPSK10M	Bottom for Laptop	0	23230	25	0	Ant 0	w/	-	1.00	19.00	18.80	1.05	-0.15	0.413	0.43
	LTE 13	QPSK10M	Lid Closed for Laptop	0	23230	1	0	Ant 0	w/	-	1.00	20.00	19.98	1.00	0.03	0.332	0.33
10	LTE 14	QPSK10M	Bottom for Laptop	0	23330	1	0	Ant 0	w/	-	1.00	23.00	22.67	1.08	0.04	0.625	0.68
	LTE 14	QPSK10M	Bottom for Laptop	0	23330	25	0	Ant 0	w/	-	1.00	22.00	21.70	1.07	0.14	0.486	0.52
	LTE 14	QPSK10M	Lid Closed for Laptop	0	23330	1	0	Ant 0	w/	-	1.00	23.00	22.67	1.08	0.08	0.387	0.42

Laptop SAR Test Result

System & Position								DUT & Accessory				SAR						
Plot No.	Band	Mode	Test Position	Separation Distance (mm)	Channel	RB#	RB offset	Ant Status	Power Reduction	Duty Cycle	Crest Factor	Max. Tune-up Power (dBm)	Measured Conducted Power (dBm)	Scaling Factor	Power Drift (dB)	Measured SAR-1g (W/kg)	Scaled SAR-1g (W/kg)	
11	LTE 17	QPSK10M	Bottom for Laptop	0	23790	1	0	Ant 0	w/	-	1.00	19.50	19.42	1.02	0.05	0.588	0.60	
	LTE 17	QPSK10M	Bottom for Laptop	0	23790	25	0	Ant 0	w/	-	1.00	18.50	18.28	1.05	0.14	0.45	0.47	
	LTE 17	QPSK10M	Bottom for Laptop	0	23780	1	0	Ant 0	w/	-	1.00	19.50	19.32	1.04	0.17	0.579	0.60	
	LTE 17	QPSK10M	Bottom for Laptop	0	23800	1	0	Ant 0	w/	-	1.00	19.50	19.16	1.08	-0.04	0.523	0.56	
	LTE 17	QPSK10M	Lid Closed for Laptop	0	23790	1	0	Ant 0	w/	-	1.00	19.50	19.42	1.02	0.18	0.376	0.38	
																	-	
12	LTE 25	QPSK20M	Bottom for Laptop	0	26590	1	0	Ant 0	w/	-	1.00	18.50	18.07	1.10	-0.09	0.476	0.52	
	LTE 25	QPSK20M	Bottom for Laptop	0	26590	50	0	Ant 0	w/	-	1.00	17.50	17.09	1.10	-0.06	0.376	0.41	
	LTE 25	QPSK20M	Bottom for Laptop	0	26140	1	0	Ant 0	w/	-	1.00	18.50	18.00	1.12	-0.04	0.466	0.52	
	LTE 25	QPSK20M	Bottom for Laptop	0	26365	1	0	Ant 0	w/	-	1.00	18.50	18.02	1.12	-0.03	0.459	0.51	
	LTE 25	QPSK20M	Lid Closed for Laptop	0	26590	1	0	Ant 0	w/	-	1.00	18.50	18.07	1.10	-0.15	0.228	0.25	
																	-	
13	LTE 26	QPSK15M	Bottom for Laptop	0	26965	1	0	Ant 0	w/	-	1.00	23.00	22.87	1.03	0.01	0.5	0.52	
	LTE 26	QPSK15M	Bottom for Laptop	0	26965	36	0	Ant 0	w/	-	1.00	22.00	21.83	1.04	-0.07	0.386	0.40	
	LTE 26	QPSK15M	Bottom for Laptop	0	26765	1	0	Ant 0	w/	-	1.00	23.00	22.83	1.04	-0.01	0.491	0.51	
	LTE 26	QPSK15M	Bottom for Laptop	0	26865	1	0	Ant 0	w/	-	1.00	23.00	22.82	1.04	-0.18	0.485	0.50	
	LTE 26	QPSK15M	Lid Closed for Laptop	0	26965	1	0	Ant 0	w/	-	1.00	23.00	22.87	1.03	-0.18	0.314	0.32	
																	-	
14	LTE 30	QPSK10M	Bottom for Laptop	0	27710	1	0	Ant 0	w/	-	1.00	21.50	20.96	1.13	-0.07	0.534	0.60	
	LTE 30	QPSK10M	Bottom for Laptop	0	27710	25	0	Ant 0	w/	-	1.00	20.50	19.98	1.13	0.09	0.432	0.49	
	LTE 30	QPSK10M	Lid Closed for Laptop	0	27710	1	0	Ant 0	w/	-	1.00	21.50	20.96	1.13	-0.02	0.416	0.47	
																	-	
	LTE 38	QPSK20M	Bottom for Laptop	0	37850	1	0	Ant 0	w/	-	1.00	20.50	20.20	1.07	-0.05	0.497	0.53	
	LTE 38	QPSK20M	Bottom for Laptop	0	37850	50	0	Ant 0	w/	-	1.00	19.50	19.03	1.11	-0.15	0.4	0.44	
	LTE 38	QPSK20M	Bottom for Laptop	0	38000	1	0	Ant 0	w/	-	1.00	20.50	20.05	1.11	0.07	0.48	0.53	
15	LTE 38	QPSK20M	Bottom for Laptop	0	38150	1	0	Ant 0	w/	-	1.00	20.50	20.18	1.08	0.04	0.512	0.55	
	LTE 38	QPSK20M	Bottom for Laptop	0	PCC : 37850 SCC : 38048	PCC : 1 SCC : 1	PCC : 0 SCC : 99	Ant 0	w/	-	1.00	20.50	20.10	1.10	-0.18	0.402	0.44	
	LTE 38	QPSK20M	Lid Closed for Laptop	0	38150	1	0	Ant 0	w/	-	1.00	20.50	20.18	1.08	-0.06	0.399	0.43	
																	-	
	LTE 40	QPSK20M	Bottom for Laptop	0	39150	1	0	Ant 0	w/	-	1.00	20.50	20.39	1.03	-0.12	0.477	0.49	
	LTE 40	QPSK20M	Bottom for Laptop	0	39150	50	0	Ant 0	w/	-	1.00	19.50	19.32	1.04	0.05	0.39	0.41	
16	LTE 40	QPSK20M	Bottom for Laptop	0	38750	1	0	Ant 0	w/	-	1.00	20.50	20.13	1.09	-0.1	0.521	0.57	
	LTE 40	QPSK20M	Bottom for Laptop	0	39550	1	0	Ant 0	w/	-	1.00	20.50	20.07	1.10	0.19	0.442	0.49	
	LTE 40	QPSK20M	Lid Closed for Laptop	0	38750	1	0	Ant 0	w/	-	1.00	20.50	20.13	1.09	0.16	0.399	0.43	
																	-	
	LTE 41	QPSK20M	Bottom for Laptop	0	41055	1	0	Ant 2	w/	-	1.00	18.00	17.60	1.10	0.15	0.347	0.38	
	LTE 41	QPSK20M	Bottom for Laptop	0	41055	50	0	Ant 2	w/	-	1.00	17.00	16.63	1.09	-0.04	0.26	0.28	
	LTE 41	QPSK20M	Bottom for Laptop	0	39750	1	0	Ant 2	w/	-	1.00	18.00	17.45	1.14	-0.17	0.392	0.45	
	LTE 41	QPSK20M	Bottom for Laptop	0	40185	1	0	Ant 2	w/	-	1.00	18.00	17.24	1.19	0.16	0.352	0.42	
17	LTE 41	QPSK20M	Bottom for Laptop	0	40620	1	0	Ant 2	w/	-	1.00	18.00	17.34	1.16	-0.02	0.404	0.47	
	LTE 41	QPSK20M	Bottom for Laptop	0	41490	1	0	Ant 2	w/	-	1.00	18.00	17.48	1.13	0.09	0.315	0.36	
	LTE 41	QPSK20M	Bottom for Laptop	0	PCC : 41055 SCC : 41253	PCC : 1 SCC : 1	PCC : 0 SCC : 99	Ant 2	w/	-	1.00	18.00	17.54	1.11	-0.03	0.298	0.33	
	LTE 41	QPSK20M	Lid Closed for Laptop	0	40620	1	0	Ant 2	w/	-	1.00	18.00	17.34	1.16	-0.15	0.32	0.37	
																	-	
20	LTE 48	QPSK20M	Bottom for Laptop	0	56640	1	0	Ant 2	w/	-	1.00	17.50	17.19	1.07	-0.11	0.315	0.34	
	LTE 48	QPSK20M	Bottom for Laptop	0	56640	50	0	Ant 2	w/	-	1.00	16.50	16.31	1.04	0.12	0.186	0.19	
	LTE 48	QPSK20M	Bottom for Laptop	0	55340	1	0	Ant 2	w/	-	1.00	17.50	16.81	1.17	0.04	0.224	0.26	
	LTE 48	QPSK20M	Bottom for Laptop	0	55780	1	0	Ant 2	w/	-	1.00	17.50	16.73	1.19	0.01	0.269	0.32	
	LTE 48	QPSK20M	Bottom for Laptop	0	56210	1	0	Ant 2	w/	-	1.00	17.50	16.99	1.12	-0.18	0.242	0.27	
	LTE 48	QPSK20M	Bottom for Laptop	0	PCC : 56640 SCC : 56442	PCC : 1 SCC : 1	PCC : 0 SCC : 99	Ant 2	w/	-	1.00	17.50	17.09	1.10	-0.06	0.264	0.29	
	LTE 48	QPSK20M	Lid Closed for Laptop	0	56640	1	0	Ant 2	w/	-	1.00	17.50	17.19	1.07	-0.06	0.178	0.19	
																	-	

### Laptop SAR Test Result

System & Position								DUT & Accessory				SAR					
Plot No.	Band	Mode	Test Position	Separation Distance (mm)	Channel	RB#	RB offset	Ant Status	Power Reduction	Duty Cycle	Crest Factor	Max. Tune-up Power (dBm)	Measured Conducted Power (dBm)	Scaling Factor	Power Drift (dB)	Measured SAR-1g (W/kg)	Scaled SAR-1g (W/kg)
21	LTE 66	QPSK20M	Bottom for Laptop	0	132322	1	0	Ant 0	w/	-	1.00	18.50	18.24	1.06	-0.02	0.586	0.62
	LTE 66	QPSK20M	Bottom for Laptop	0	132322	50	0	Ant 0	w/	-	1.00	17.50	17.11	1.09	0.18	0.462	0.50
	LTE 66	QPSK20M	Bottom for Laptop	0	132072	1	0	Ant 0	w/	-	1.00	18.50	18.21	1.07	0.15	0.548	0.59
	LTE 66	QPSK20M	Bottom for Laptop	0	132572	1	0	Ant 0	w/	-	1.00	18.50	18.20	1.07	0.17	0.563	0.60
21	LTE 66	QPSK20M	Bottom for Laptop	0	PCC : 132323 SCC : 132521	PCC : 1 SCC : 1	PCC : 0 SCC : 99	Ant 0	w/	-	1.00	18.50	18.15	1.08	-0.15	0.467	0.50
	LTE 66	QPSK20M	Lid Closed for Laptop	0	132322	1	0	Ant 0	w/	-	1.00	18.50	18.24	1.06	0.16	0.252	0.27
22	LTE 71	QPSK20M	Bottom for Laptop	0	133297	1	0	Ant 0	w/	-	1.00	23.00	22.83	1.04	0.04	0.655	0.68
	LTE 71	QPSK20M	Bottom for Laptop	0	133297	50	0	Ant 0	w/	-	1.00	22.00	21.93	1.02	-0.14	0.515	0.53
	LTE 71	QPSK20M	Bottom for Laptop	0	133222	1	0	Ant 0	w/	-	1.00	23.00	22.78	1.05	0.09	0.532	0.56
	LTE 71	QPSK20M	Bottom for Laptop	0	133372	1	0	Ant 0	w/	-	1.00	23.00	22.74	1.06	-0.19	0.637	0.68
	LTE 71	QPSK20M	Lid Closed for Laptop	0	133297	1	0	Ant 0	w/	-	1.00	23.00	22.83	1.04	-0.14	0.376	0.39
23	5GNR-n2	DFT-S QPSK20M	Bottom for Laptop	0	376000	1	1	Ant 0	w/	-	1.00	16.50	16.48	1.00	-0.07	0.553	0.55
	5GNR-n2	DFT-S QPSK20M	Bottom for Laptop	0	376000	50	28	Ant 0	w/	-	1.00	16.50	15.89	1.15	-0.18	0.477	0.55
	5GNR-n2	DFT-S QPSK20M	Bottom for Laptop	0	372000	1	0	Ant 0	w/	-	1.00	16.50	16.44	1.01	-0.03	0.456	0.46
	5GNR-n2	DFT-S QPSK20M	Bottom for Laptop	0	380000	1	0	Ant 0	w/	-	1.00	16.50	16.43	1.02	0.01	0.473	0.48
	5GNR-n2	DFT-S QPSK20M	Lid Closed for Laptop	0	376000	1	0	Ant 0	w/	-	1.00	16.50	16.48	1.00	-0.03	0.2	0.20
24	5GNR-n5	DFT-S QPSK20M	Bottom for Laptop	0	167300	1	1	Ant 0	w/	-	1.00	20.00	19.36	1.16	-0.04	0.502	0.58
	5GNR-n5	DFT-S QPSK20M	Bottom for Laptop	0	167300	50	28	Ant 0	w/	-	1.00	20.00	19.34	1.16	-0.12	0.434	0.50
	5GNR-n5	DFT-S QPSK20M	Bottom for Laptop	0	166800	1	1	Ant 0	w/	-	1.00	20.00	19.14	1.22	-0.13	0.479	0.58
	5GNR-n5	DFT-S QPSK20M	Bottom for Laptop	0	167800	1	1	Ant 0	w/	-	1.00	20.00	19.15	1.22	0	0.478	0.58
	5GNR-n5	DFT-S QPSK20M	Lid Closed for Laptop	0	167300	1	1	Ant 0	w/	-	1.00	20.00	19.36	1.16	-0.08	0.233	0.27
25	5GNR-n7	DFT-S QPSK20M	Bottom for Laptop	0	507000	1	1	Ant 0	w/	-	1.00	16.00	15.32	1.17	-0.09	0.335	0.39
	5GNR-n7	DFT-S QPSK20M	Bottom for Laptop	0	507000	50	28	Ant 0	w/	-	1.00	16.00	15.31	1.17	0.01	0.317	0.37
	5GNR-n7	DFT-S QPSK20M	Bottom for Laptop	0	502000	1	1	Ant 0	w/	-	1.00	16.00	15.22	1.20	-0.06	0.352	0.42
26	5GNR-n7	DFT-S QPSK20M	Bottom for Laptop	0	512000	1	1	Ant 0	w/	-	1.00	16.00	15.17	1.21	0.19	0.326	0.39
	5GNR-n7	DFT-S QPSK20M	Lid Closed for Laptop	0	502000	1	1	Ant 0	w/	-	1.00	16.00	15.22	1.20	0.19	0.211	0.25
	5GNR-n25	DFT-S QPSK20M	Bottom for Laptop	0	381000	1	1	Ant 0	w/	-	1.00	16.50	16.49	1.00	-0.01	0.572	0.57
	5GNR-n25	DFT-S QPSK20M	Bottom for Laptop	0	381000	50	28	Ant 0	w/	-	1.00	16.50	15.75	1.19	-0.18	0.471	0.56
27	5GNR-n25	DFT-S QPSK20M	Bottom for Laptop	0	372000	1	1	Ant 0	w/	-	1.00	16.50	16.45	1.01	-0.15	0.563	0.57
	5GNR-n25	DFT-S QPSK20M	Bottom for Laptop	0	376500	1	1	Ant 0	w/	-	1.00	16.50	16.43	1.02	0.12	0.558	0.57
	5GNR-n25	DFT-S QPSK20M	Lid Closed for Laptop	0	381000	1	1	Ant 0	w/	-	1.00	16.50	16.49	1.00	0.05	0.269	0.27
	5GNR-n30	DFT-S QPSK10M	Bottom for Laptop	0	462000	1	1	Ant 0	w/	-	1.00	18.50	18.24	1.06	-0.11	0.577	0.61
28	5GNR-n30	DFT-S QPSK10M	Bottom for Laptop	0	462000	25	14	Ant 0	w/	-	1.00	18.50	17.81	1.17	-0.06	0.519	0.61
	5GNR-n30	DFT-S QPSK10M	Lid Closed for Laptop	0	462000	1	1	Ant 0	w/	-	1.00	18.50	18.24	1.06	-0.09	0.357	0.38
28	5GNR-n38	DFT-S QPSK20M	Bottom for Laptop	0	519000	1	1	Ant 0	w/	-	1.00	19.00	18.79	1.05	-0.15	0.529	0.56
	5GNR-n38	DFT-S QPSK20M	Bottom for Laptop	0	519000	25	13	Ant 0	w/	-	1.00	19.00	18.61	1.09	0.16	0.51	0.56
	5GNR-n38	DFT-S QPSK20M	Bottom for Laptop	0	516000	1	1	Ant 0	w/	-	1.00	19.00	18.74	1.06	0.13	0.506	0.54
	5GNR-n38	DFT-S QPSK20M	Bottom for Laptop	0	522000	1	1	Ant 0	w/	-	1.00	19.00	18.71	1.07	0.1	0.469	0.50
	5GNR-n38	DFT-S QPSK20M	Lid Closed for Laptop	0	519000	1	1	Ant 0	w/	-	1.00	19.00	18.79	1.05	-0.09	0.304	0.32
29	5GNR-n40	DFT-S QPSK80M	Bottom for Laptop	0	470000	1	1	Ant 0	w/	-	1.00	18.00	17.77	1.05	0.03	0.46	0.48
	5GNR-n40	DFT-S QPSK80M	Bottom for Laptop	0	470000	108	55	Ant 0	w/	-	1.00	18.00	17.66	1.08	0.13	0.441	0.48
	5GNR-n40	DFT-S QPSK80M	Bottom for Laptop	0	468000	1	1	Ant 0	w/	-	1.00	18.00	17.74	1.06	-0.12	0.517	0.55
29	5GNR-n40	DFT-S QPSK80M	Bottom for Laptop	0	472000	1	1	Ant 0	w/	-	1.00	18.00	17.71	1.07	0.1	0.467	0.50
	5GNR-n40	DFT-S QPSK80M	Lid Closed for Laptop	0	468000	1	1	Ant 0	w/	-	1.00	18.00	17.74	1.06	0.12	0.259	0.27



## Laptop SAR Test Result

System & Position								DUT & Accessory		SAR							
Plot No.	Band	Mode	Test Position	Separation Distance (mm)	Channel	RB#	RB offset	Ant Status	Power Reduction	Duty Cycle	Crest Factor	Max. Tune-up Power (dBm)	Measured Conducted Power (dBm)	Scaling Factor	Power Drift (dB)	Measured SAR-1g (W/kg)	Scaled SAR-1g (W/kg)
	5G NR-n41	DFT-S QPSK100M	Bottom for Laptop	0	518598	1	1	Ant 2	w/	-	1.00	17.00	16.99	1.00	0.09	0.503	0.50
	5G NR-n41	DFT-S QPSK100M	Bottom for Laptop	0	518598	135	69	Ant 2	w/	-	1.00	17.00	16.51	1.12	-0.04	0.346	0.39
30	5G NR-n41	DFT-S QPSK100M	Bottom for Laptop	0	509202	1	1	Ant 2	w/	-	1.00	17.00	16.71	1.08	0.02	0.583	0.63
	5G NR-n41	DFT-S QPSK100M	Bottom for Laptop	0	513900	1	1	Ant 2	w/	-	1.00	17.00	16.68	1.08	-0.01	0.497	0.54
	5G NR-n41	DFT-S QPSK100M	Bottom for Laptop	0	523302	1	1	Ant 2	w/	-	1.00	17.00	16.65	1.06	-0.12	0.559	0.59
	5G NR-n41	DFT-S QPSK100M	Bottom for Laptop	0	528000	1	1	Ant 2	w/	-	1.00	17.00	16.73	1.02	-0.1	0.489	0.50
	5G NR-n41	DFT-S QPSK100M	Lid Closed for Laptop	0	509202	1	1	Ant 2	w/	-	1.00	17.00	16.71	1.07	0.08	0.322	0.34
																	-
32	5G NR-n66	DFT-S QPSK40M	Bottom for Laptop	0	349000	1	1	Ant 0	w/	-	1.00	17.00	16.99	1.00	-0.04	0.541	0.54
	5G NR-n66	DFT-S QPSK40M	Bottom for Laptop	0	349000	108	54	Ant 0	w/	-	1.00	17.00	16.34	1.16	-0.05	0.468	0.54
	5G NR-n66	DFT-S QPSK40M	Bottom for Laptop	0	346000	1	1	Ant 0	w/	-	1.00	17.00	16.75	1.06	-0.03	0.48	0.51
	5G NR-n66	DFT-S QPSK40M	Bottom for Laptop	0	352000	1	1	Ant 0	w/	-	1.00	17.00	16.78	1.05	-0.07	0.49	0.51
	5G NR-n66	DFT-S QPSK40M	Lid Closed for Laptop	0	349000	1	1	Ant 0	w/	-	1.00	17.00	16.99	1.00	-0.02	0.224	0.22
																	-
33	5G NR-n71	DFT-S QPSK20M	Bottom for Laptop	0	136100	1	1	Ant 0	w/	-	1.00	20.00	19.99	1.00	0.04	0.634	0.63
	5G NR-n71	DFT-S QPSK20M	Bottom for Laptop	0	136100	50	28	Ant 0	w/	-	1.00	20.00	19.21	1.20	-0.01	0.51	0.61
	5G NR-n71	DFT-S QPSK20M	Bottom for Laptop	0	134600	1	1	Ant 0	w/	-	1.00	20.00	19.89	1.03	-0.05	0.57	0.59
	5G NR-n71	DFT-S QPSK20M	Bottom for Laptop	0	137600	1	1	Ant 0	w/	-	1.00	20.00	19.91	1.02	-0.07	0.56	0.57
	5G NR-n71	DFT-S QPSK20M	Lid Closed for Laptop	0	136100	1	1	Ant 0	w/	-	1.00	20.00	19.99	1.00	-0.17	0.34	0.34
																	-
	5G NR-n77	DFT-S QPSK100M	Bottom for Laptop	0	653000	1	1	Ant 2	w/	-	1.00	20.50	20.49	1.00	0.03	0.611	0.61
	5G NR-n77	DFT-S QPSK100M	Bottom for Laptop	0	653000	135	69	Ant 2	w/	-	1.00	20.50	20.17	1.08	-0.16	0.547	0.59
	5G NR-n77	DFT-S QPSK100M	Bottom for Laptop	0	650000	1	1	Ant 2	w/	-	1.00	20.50	20.47	1.01	-0.15	0.612	0.62
	5G NR-n77	DFT-S QPSK100M	Bottom for Laptop	0	656000	1	1	Ant 2	w/	-	1.00	20.50	20.36	1.03	0.07	0.623	0.64
34	5G NR-n77	DFT-S QPSK100M	Bottom for Laptop	0	659000	1	1	Ant 2	w/	-	1.00	20.50	20.41	1.02	-0.09	0.658	0.67
	5G NR-n77	DFT-S QPSK100M	Bottom for Laptop	0	662000	1	1	Ant 2	w/	-	1.00	20.50	19.93	1.14	-0.15	0.587	0.67
	5G NR-n77	DFT-S QPSK100M	Lid Closed for Laptop	0	659000	1	1	Ant 2	w/	-	1.00	20.50	20.41	1.02	-0.16	0.37	0.38
																	-
35	5G NR-n78	DFT-S QPSK100M	Bottom for Laptop	0	650000	1	1	Ant 2	w/	-	1.00	21.00	20.98	1.00	-0.06	0.654	0.65
	5G NR-n78	DFT-S QPSK100M	Bottom for Laptop	0	650000	135	69	Ant 2	w/	-	1.00	21.00	20.78	1.05	0.05	0.593	0.62
	5G NR-n78	DFT-S QPSK100M	Lid Closed for Laptop	0	650000	1	1	Ant 2	w/	-	1.00	21.00	20.98	1.00	0.08	0.386	0.39

### Laptop SAR Test Result

System & Position								DUT & Accessory		SAR							
Plot No.	Band	Mode	Test Position	Separation Distance (mm)	Channel	RB#	RB offset	Ant Status	Power Reduction	Duty Cycle	Crest Factor	Max. Tune-up Power (dBm)	Measured Conducted Power (dBm)	Scaling Factor	Power Drift (dB)	Measured SAR-1g (W/kg)	Scaled SAR-1g (W/kg)
	WLAN2.4G	802.11b	Bottom for Laptop	0	6			Ant 0		98.60	1.01	20.00	19.96	1.01	0	<0.001	0.00
	WLAN2.4G	802.11b	Bottom for Laptop	0	6			Ant 1		98.60	1.01	20.00	19.96	1.01	0	<0.001	0.00
	WLAN2.4G	802.11n HT20	Bottom for Laptop	0	6			Ant 0+1		100.00	1.00	23.00	22.95	1.01	0	<0.001	0.00
36	WLAN2.4G	802.11n HT20	Lid Closed for Laptop	0	6			Ant 0+1		100.00	1.00	23.00	22.95	1.01	-0.04	0.161	0.16
	WLAN2.4G	802.11n HT20	Lid Closed for Laptop	0	1			Ant 0+1		100.00	1.00	19.50	19.45	1.01	-0.09	0.085	0.09
	WLAN2.4G	802.11n HT20	Lid Closed for Laptop	0	11			Ant 0+1		100.00	1.00	19.50	19.49	1.00	0.19	0.079	0.08
	WLAN2.4G	802.11n HT20	Lid Closed for Laptop	0	12			Ant 0+1		100.00	1.00	14.25	14.24	1.00	-0.17	0.027	0.03
	WLAN2.4G	802.11n HT20	Lid Closed for Laptop	0	13			Ant 0+1		100.00	1.00	11.50	11.47	1.01	0.03	0.011	0.01
	WLAN5.3G	802.11a	Bottom for Laptop	0	60			Ant 0		93.20	1.07	20.00	19.98	1.00	0	<0.001	0.00
	WLAN5.3G	802.11n HT40	Bottom for Laptop	0	54			Ant 1		98.20	1.02	20.00	19.98	1.00	0	<0.001	0.00
	WLAN5.3G	802.11n HT40	Bottom for Laptop	0	54			Ant 0+1		99.00	1.01	23.00	22.97	1.01	0	<0.001	0.00
37	WLAN5.3G	802.11n HT40	Lid Closed for Laptop	0	54			Ant 0+1		99.00	1.01	23.00	22.97	1.01	-0.12	0.519	0.53
	WLAN5.3G	802.11n HT40	Lid Closed for Laptop	0	62			Ant 0+1		99.00	1.01	19.50	19.47	1.01	0.16	0.223	0.23
	WLAN5.6G	802.11ac VHT80	Bottom for Laptop	0	138			Ant 0		97.90	1.02	20.00	19.98	1.00	0	<0.001	0.00
	WLAN5.6G	802.11ac VHT80	Bottom for Laptop	0	138			Ant 1		98.10	1.02	20.00	19.98	1.00	0	<0.001	0.00
	WLAN5.6G	802.11n HT40	Bottom for Laptop	0	134			Ant 0+1		99.00	1.01	22.50	22.45	1.01	0	<0.001	0.00
38	WLAN5.6G	802.11ac VHT80	Lid Closed for Laptop	0	138			Ant 1		98.10	1.02	20.00	19.98	1.00	-0.09	0.29	0.30
	WLAN5.6G	802.11ac VHT80	Lid Closed for Laptop	0	106			Ant 1		98.10	1.02	18.75	18.72	1.01	0.05	0.237	0.24
	WLAN5.8G	802.11ac VHT80	Bottom for Laptop	0	155			Ant 0		97.90	1.02	20.00	19.98	1.00	0	<0.001	0.00
	WLAN5.8G	802.11ac VHT80	Bottom for Laptop	0	155			Ant 1		98.10	1.02	20.00	19.95	1.01	0	<0.001	0.00
	WLAN5.8G	802.11n HT40	Bottom for Laptop	0	151			Ant 0+1		99.00	1.01	23.00	22.97	1.01	0	<0.001	0.00
39	WLAN5.8G	802.11ac VHT80	Lid Closed for Laptop	0	155			Ant 0		97.90	1.02	20.00	19.98	1.00	0.13	0.744	0.76
	BT	BDR	Bottom for Laptop	0	78			Ant 1		76.30	1.31	11.00	9.68	1.36	0	<0.001	0.00
40	BT	BDR	Lid Closed for Laptop	0	78			Ant 1		76.30	1.31	11.00	9.68	1.36	-0.08	0.0051	0.01
	BT	BDR	Lid Closed for Laptop	0	0			Ant 1		76.30	1.31	11.00	9.03	1.57	0	<0.001	0.00
	BT	BDR	Lid Closed for Laptop	0	39			Ant 1		76.30	1.31	11.00	9.25	1.50	0	<0.001	0.00

**SAR and Power Density Test Result**

System & Position				DUT & Accessory		SAR									Power Density									
Plot No.	Band	Mode	Test Position	Separation Distance (mm)	Channel	Ant Status	Duty Cycle	Crest Factor	Max. Tune-up Power (dBm)	Measured Conducted Power (dBm)	Scaling Factor	Power Drift (dB)	Measured SAR-1g (W/kg)	Scaled SAR-1g (W/kg)	Measured APD W/m <sup>2</sup> (4cm <sup>2</sup> )	Grid Step [λ]	iPD [W/m2]	Scaling Factor for Measurement Uncertainty	Averaging Area [cm2]	Power Drift [dB]	Normal psPD [W/m2]	Scaled Normal psPD [W/m2]	Total psPD [W/m2]	Scaled Total psPD [W/m2]
	UNII-5	802.11ax HE160	Bottom for Laptop	0	15	Ant 0	98.50	1.02	13.00	12.98	1.00	0	<0.001	0.00	0			-				-		-
	UNII-5	802.11ax HE160	Bottom for Laptop	0	15	Ant 1	98.50	1.02	13.00	12.97	1.01	0	<0.001	0.00	0			-				-		-
	UNII-5	802.11ax HE160	Bottom for Laptop	0	15	Ant 0+1	96.50	1.04	13.50	13.46	1.01	0	<0.001	0.00	0			-				-		-
	UNII-5	802.11ax HE160	Bottom for Laptop	0	47	Ant 0	98.50	1.02	13.00	12.93	1.02	0	<0.001	0.00	3.3			-				-		-
	UNII-5	802.11ax HE160	Bottom for Laptop	0	79	Ant 0	98.50	1.02	13.00	12.97	1.01	0	<0.001	0.00	2.79			-				-		-
	UNII-6	802.11ax HE160	Bottom for Laptop	0	111	Ant 0	98.50	1.02	13.00	12.98	1.00	0	<0.001	0.00	2.07			-				-		-
	UNII-7	802.11ax HE160	Bottom for Laptop	0	143	Ant 0	98.50	1.02	12.75	12.72	1.01	0	<0.001	0.00	2.15			-				-		-
	UNII-7	802.11ax HE160	Bottom for Laptop	0	175	Ant 0	98.50	1.02	12.75	12.69	1.01	0	<0.001	0.00	2.01			-				-		-
	UNII-8	802.11ax HE160	Bottom for Laptop	0	207	Ant 0	98.50	1.02	12.75	12.63	1.03	0	<0.001	0.00	1.88			-				-		-
41	UNII-5	802.11ax HE160	Lid Closed for Laptop	0	15	Ant 0	98.50	1.02	13.00	12.98	1.00	0.05	0.305	0.31	2.85	0.25	8.73	1.545	4.00	0.13	1.01	1.59	1.01	1.59
																		-				-		-

## **Annex G. SAR Measurement Variability**

Since all the measured SAR<sub>1g</sub> are less than 0.8 W/kg, the repeated measurement is not required.

## Annex H. Analysis of Simultaneous Transmission SAR.

The analysis of simultaneous transmission SAR are shown as below.

### <Possibilities of Simultaneous Transmission>

The simultaneous transmission possibilities for this device are listed as below.

Simultaneous TX Combination	Capable Transmit Configurations	Body Exposure Condition
A	WWAN + WLAN 2.4G_Ant 0 + BT_Ant 1	Yes
B	WWAN + WLAN 5G_Ant 0 + BT_Ant 1	Yes
C	WWAN + WLAN 5G_Ant 0+1 + BT_Ant 1	Yes
D	WWAN + WIFI 6E_Ant 0 + BT_Ant 1	Yes
E	WWAN + WIFI 6E_Ant 0+1 + BT_Ant 1	Yes
F	WLAN 2.4G_Ant 0 + BT_Ant 1	Yes
G	WLAN 5G_Ant 0 + BT_Ant 1	Yes
H	WLAN 5G_Ant 0+1 + BT_Ant 1	Yes
I	WIFI 6E_Ant 0 + BT_Ant 1	Yes
J	WIFI 6E_Ant 0+1 + BT_Ant 1	Yes

#### Notes

1. The WLAN 2.4G and WLAN 5G cannot transmit simultaneously.
2. The WLAN and Bluetooth cannot transmit simultaneously.
3. Simultaneous TX Combination F, G, H, I and J can be covered by A, B, C, D, E.

Simultaneous Transmission SAR Evaluation (Body)

Band	Position	1	2	3	4	5	6	7	A(1+2+7)	B(1+3+7)	C(1+4+7)	D(1+5+7)	E(1+6+7)
		Max WWAN	WLAN 2.4GHz Ant 0	WLAN 5GHz Ant 0	WLAN 5GHz Ant 0+1	WLAN 6E Ant 0	WLAN 6E Ant 0+1	BT Ant 1	Summimg result 1g SAR W/kg	Summimg result 1g SAR W/kg	Summimg result 1g SAR W/kg	Summimg result 1g SAR W/kg	Summimg result 1g SAR W/kg
		1g SAR W/kg	1g SAR W/kg	1g SAR W/kg	1g SAR W/kg	1g SAR W/kg	1g SAR W/kg	1g SAR W/kg					
WCDMA II	Bottom for Laptop	0.65	0.00	0.00	0.00	0.00	0.00	0.00	0.65	0.65	0.65	0.65	0.65
	Lid Closed for Laptop	0.31	0.00	0.76	0.53	0.31	0.00	0.01	0.32	1.08	0.85	0.63	0.32
WCDMA IV	Bottom for Laptop	0.58	0.00	0.00	0.00	0.00	0.00	0.00	0.58	0.58	0.58	0.58	0.58
	Lid Closed for Laptop	0.28	0.00	0.76	0.53	0.31	0.00	0.01	0.29	1.05	0.82	0.60	0.29
WCDMA V	Bottom for Laptop	0.27	0.00	0.00	0.00	0.00	0.00	0.00	0.27	0.27	0.27	0.27	0.27
	Lid Closed for Laptop	0.16	0.00	0.76	0.53	0.31	0.00	0.01	0.17	0.93	0.70	0.48	0.17
LTE 2	Bottom for Laptop	0.65	0.00	0.00	0.00	0.00	0.00	0.00	0.65	0.65	0.65	0.65	0.65
	Lid Closed for Laptop	0.33	0.00	0.76	0.53	0.31	0.00	0.01	0.34	1.10	0.87	0.65	0.34
LTE 4	Bottom for Laptop	0.65	0.00	0.00	0.00	0.00	0.00	0.00	0.65	0.65	0.65	0.65	0.65
	Lid Closed for Laptop	0.29	0.00	0.76	0.53	0.31	0.00	0.01	0.30	1.06	0.83	0.61	0.30
LTE 5	Bottom for Laptop	0.53	0.00	0.00	0.00	0.00	0.00	0.00	0.53	0.53	0.53	0.53	0.53
	Lid Closed for Laptop	0.40	0.00	0.76	0.53	0.31	0.00	0.01	0.41	1.17	0.94	0.72	0.41
LTE 7	Bottom for Laptop	0.60	0.00	0.00	0.00	0.00	0.00	0.00	0.60	0.60	0.60	0.60	0.60
	Lid Closed for Laptop	0.47	0.00	0.76	0.53	0.31	0.00	0.01	0.48	1.24	1.01	0.79	0.48
LTE 12	Bottom for Laptop	0.58	0.00	0.00	0.00	0.00	0.00	0.00	0.58	0.58	0.58	0.58	0.58
	Lid Closed for Laptop	0.36	0.00	0.76	0.53	0.31	0.00	0.01	0.37	1.13	0.90	0.68	0.37
LTE 13	Bottom for Laptop	0.52	0.00	0.00	0.00	0.00	0.00	0.00	0.52	0.52	0.52	0.52	0.52
	Lid Closed for Laptop	0.33	0.00	0.76	0.53	0.31	0.00	0.01	0.34	1.10	0.87	0.65	0.34
LTE 14	Bottom for Laptop	0.68	0.00	0.00	0.00	0.00	0.00	0.00	0.68	0.68	0.68	0.68	0.68
	Lid Closed for Laptop	0.42	0.00	0.76	0.53	0.31	0.00	0.01	0.43	1.19	0.96	0.74	0.43
LTE 17	Bottom for Laptop	0.60	0.00	0.00	0.00	0.00	0.00	0.00	0.60	0.60	0.60	0.60	0.60
	Lid Closed for Laptop	0.38	0.00	0.76	0.53	0.31	0.00	0.01	0.39	1.15	0.92	0.70	0.39
LTE 25	Bottom for Laptop	0.52	0.00	0.00	0.00	0.00	0.00	0.00	0.52	0.52	0.52	0.52	0.52
	Lid Closed for Laptop	0.25	0.00	0.76	0.53	0.31	0.00	0.01	0.26	1.02	0.79	0.57	0.26
LTE 26	Bottom for Laptop	0.52	0.00	0.00	0.00	0.00	0.00	0.00	0.52	0.52	0.52	0.52	0.52
	Lid Closed for Laptop	0.32	0.00	0.76	0.53	0.31	0.00	0.01	0.33	1.09	0.86	0.64	0.33
LTE 30	Bottom for Laptop	0.60	0.00	0.00	0.00	0.00	0.00	0.00	0.60	0.60	0.60	0.60	0.60
	Lid Closed for Laptop	0.47	0.00	0.76	0.53	0.31	0.00	0.01	0.48	1.24	1.01	0.79	0.48
LTE 38	Bottom for Laptop	0.55	0.00	0.00	0.00	0.00	0.00	0.00	0.55	0.55	0.55	0.55	0.55
	Lid Closed for Laptop	0.43	0.00	0.76	0.53	0.31	0.00	0.01	0.44	1.20	0.97	0.75	0.44
LTE 40	Bottom for Laptop	0.57	0.00	0.00	0.00	0.00	0.00	0.00	0.57	0.57	0.57	0.57	0.57
	Lid Closed for Laptop	0.43	0.00	0.76	0.53	0.31	0.00	0.01	0.44	1.20	0.97	0.75	0.44
LTE 41	Bottom for Laptop	0.47	0.00	0.00	0.00	0.00	0.00	0.00	0.47	0.47	0.47	0.47	0.47
	Lid Closed for Laptop	0.37	0.00	0.76	0.53	0.31	0.00	0.01	0.38	1.14	0.91	0.69	0.38

Simultaneous Transmission SAR Evaluation (Body)													
Band	Position	1	2	3	4	5	6	7	A(1+2+7)	B(1+3+7)	C(1+4+7)	D(1+5+7)	E(1+6+7)
		Max WWAN	WLAN 2.4GHz Ant 0	WLAN 5GHz Ant 0	WLAN 5GHz Ant 0+1	WLAN 6E Ant 0	WLAN 6E Ant 0+1	BT Ant 1	Summimg result 1g SAR W/kg	Summimg result 1g SAR W/kg	Summimg result 1g SAR W/kg	Summimg result 1g SAR W/kg	Summimg result 1g SAR W/kg
		1g SAR W/kg	1g SAR W/kg	1g SAR W/kg	1g SAR W/kg	1g SAR W/kg	1g SAR W/kg	1g SAR W/kg					
LTE 48	Bottom for Laptop	0.34	0.00	0.00	0.00	0.00	0.00	0.00	0.34	0.34	0.34	0.34	0.34
	Lid Closed for Laptop	0.19	0.00	0.76	0.53	0.31	0.00	0.01	0.20	0.96	0.73	0.51	0.20
LTE 66	Bottom for Laptop	0.62	0.00	0.00	0.00	0.00	0.00	0.00	0.62	0.62	0.62	0.62	0.62
	Lid Closed for Laptop	0.27	0.00	0.76	0.53	0.31	0.00	0.01	0.28	1.04	0.81	0.59	0.28
LTE 71	Bottom for Laptop	0.68	0.00	0.00	0.00	0.00	0.00	0.00	0.68	0.68	0.68	0.68	0.68
	Lid Closed for Laptop	0.39	0.00	0.76	0.53	0.31	0.00	0.01	0.40	1.16	0.93	0.71	0.40
5G NR-n2	Bottom for Laptop	0.55	0.00	0.00	0.00	0.00	0.00	0.00	0.55	0.55	0.55	0.55	0.55
	Lid Closed for Laptop	0.20	0.00	0.76	0.53	0.31	0.00	0.01	0.21	0.97	0.74	0.52	0.21
5G NR-n5	Bottom for Laptop	0.58	0.00	0.00	0.00	0.00	0.00	0.00	0.58	0.58	0.58	0.58	0.58
	Lid Closed for Laptop	0.27	0.00	0.76	0.53	0.31	0.00	0.01	0.28	1.04	0.81	0.59	0.28
5G NR-n7	Bottom for Laptop	0.42	0.00	0.00	0.00	0.00	0.00	0.00	0.42	0.42	0.42	0.42	0.42
	Lid Closed for Laptop	0.25	0.00	0.76	0.53	0.31	0.00	0.01	0.26	1.02	0.79	0.57	0.26
5G NR-n25	Bottom for Laptop	0.57	0.00	0.00	0.00	0.00	0.00	0.00	0.57	0.57	0.57	0.57	0.57
	Lid Closed for Laptop	0.27	0.00	0.76	0.53	0.31	0.00	0.01	0.28	1.04	0.81	0.59	0.28
5G NR-n30	Bottom for Laptop	0.61	0.00	0.00	0.00	0.00	0.00	0.00	0.61	0.61	0.61	0.61	0.61
	Lid Closed for Laptop	0.38	0.00	0.76	0.53	0.31	0.00	0.01	0.39	1.15	0.92	0.70	0.39
5G NR-n38	Bottom for Laptop	0.56	0.00	0.00	0.00	0.00	0.00	0.00	0.56	0.56	0.56	0.56	0.56
	Lid Closed for Laptop	0.32	0.00	0.76	0.53	0.31	0.00	0.01	0.33	1.09	0.86	0.64	0.33
5G NR-n40	Bottom for Laptop	0.55	0.00	0.00	0.00	0.00	0.00	0.00	0.55	0.55	0.55	0.55	0.55
	Lid Closed for Laptop	0.27	0.00	0.76	0.53	0.31	0.00	0.01	0.28	1.04	0.81	0.59	0.28
5G NR-n41	Bottom for Laptop	0.63	0.00	0.00	0.00	0.00	0.00	0.00	0.63	0.63	0.63	0.63	0.63
	Lid Closed for Laptop	0.34	0.00	0.76	0.53	0.31	0.00	0.01	0.35	1.11	0.88	0.66	0.35
5G NR-n66	Bottom for Laptop	0.54	0.00	0.00	0.00	0.00	0.00	0.00	0.54	0.54	0.54	0.54	0.54
	Lid Closed for Laptop	0.22	0.00	0.76	0.53	0.31	0.00	0.01	0.23	0.99	0.76	0.54	0.23
5G NR-n71	Bottom for Laptop	0.63	0.00	0.00	0.00	0.00	0.00	0.00	0.63	0.63	0.63	0.63	0.63
	Lid Closed for Laptop	0.34	0.00	0.76	0.53	0.31	0.00	0.01	0.35	1.11	0.88	0.66	0.35
5G NR-n77	Bottom for Laptop	0.67	0.00	0.00	0.00	0.00	0.00	0.00	0.67	0.67	0.67	0.67	0.67
	Lid Closed for Laptop	0.38	0.00	0.76	0.53	0.31	0.00	0.01	0.39	1.15	0.92	0.70	0.39
5G NR-n78	Bottom for Laptop	0.65	0.00	0.00	0.00	0.00	0.00	0.00	0.65	0.65	0.65	0.65	0.65
	Lid Closed for Laptop	0.39	0.00	0.76	0.53	0.31	0.00	0.01	0.40	1.16	0.93	0.71	0.40

Simultaneous Transmission SAR Evaluation (ENDC-Body)															
Band	Band	Position	1	2	3	4	5	6	7	8	A(1+2+3+8)	B(1+2+4+8)	C(1+2+5+8)	D(1+2+6+8)	E(1+2+7+8)
			Max WWAN	Max NR	WLAN 2.4GHz Ant 0	WLAN 5GHz Ant 0	WLAN 5GHz Ant 0+1	WLAN 6E Ant 0	WLAN 6E Ant 0+1	BT Ant 1	Summimg result	Summimg result	Summimg result	Summimg result	Summimg result
			1g SAR W/kg	1g SAR W/kg	1g SAR W/kg	1g SAR W/kg	1g SAR W/kg	1g SAR W/kg	1g SAR W/kg	1g SAR W/kg	1g SAR W/kg	1g SAR W/kg	1g SAR W/kg	1g SAR W/kg	1g SAR W/kg
LTE 2	5G NR-n5	Bottom for Laptop	0.65	0.58	0.00	0.00	0.00	0.00	0.00	0.00	1.23	1.23	1.23	1.23	1.23
		Lid Closed for Laptop	0.33	0.27	0.00	0.76	0.53	0.31	0.00	0.01	0.61	1.37	1.14	0.92	0.61
LTE 2	5G NR-n71	Bottom for Laptop	0.65	0.63	0.00	0.00	0.00	0.00	0.00	0.00	1.28	1.28	1.28	1.28	1.28
		Lid Closed for Laptop	0.33	0.34	0.00	0.76	0.53	0.31	0.00	0.01	0.68	1.44	1.21	0.99	0.68
LTE 2	5G NR-n78	Bottom for Laptop	0.65	0.65	0.00	0.00	0.00	0.00	0.00	0.00	1.30	1.30	1.30	1.30	1.30
		Lid Closed for Laptop	0.33	0.39	0.00	0.76	0.53	0.31	0.00	0.01	0.73	1.49	1.26	1.04	0.73
LTE 5	5G NR-n2	Bottom for Laptop	0.53	0.55	0.00	0.00	0.00	0.00	0.00	0.00	1.08	1.08	1.08	1.08	1.08
		Lid Closed for Laptop	0.40	0.20	0.00	0.76	0.53	0.31	0.00	0.01	0.61	1.37	1.14	0.92	0.61
LTE 5	5G NR-n66	Bottom for Laptop	0.53	0.54	0.00	0.00	0.00	0.00	0.00	0.00	1.07	1.07	1.07	1.07	1.07
		Lid Closed for Laptop	0.40	0.22	0.00	0.76	0.53	0.31	0.00	0.01	0.63	1.39	1.16	0.94	0.63
LTE 5	5G NR-n78	Bottom for Laptop	0.53	0.65	0.00	0.00	0.00	0.00	0.00	0.00	1.18	1.18	1.18	1.18	1.18
		Lid Closed for Laptop	0.40	0.39	0.00	0.76	0.53	0.31	0.00	0.01	0.80	1.56	1.33	1.11	0.80
LTE 12	5G NR-n2	Bottom for Laptop	0.58	0.55	0.00	0.00	0.00	0.00	0.00	0.00	1.13	1.13	1.13	1.13	1.13
		Lid Closed for Laptop	0.36	0.20	0.00	0.76	0.53	0.31	0.00	0.01	0.57	1.33	1.10	0.88	0.57
LTE 12	5G NR-n41	Bottom for Laptop	0.58	0.63	0.00	0.00	0.00	0.00	0.00	0.00	1.21	1.21	1.21	1.21	1.21
		Lid Closed for Laptop	0.36	0.34	0.00	0.76	0.53	0.31	0.00	0.01	0.71	1.47	1.24	1.02	0.71
LTE 12	5G NR-n66	Bottom for Laptop	0.58	0.54	0.00	0.00	0.00	0.00	0.00	0.00	1.12	1.12	1.12	1.12	1.12
		Lid Closed for Laptop	0.36	0.22	0.00	0.76	0.53	0.31	0.00	0.01	0.59	1.35	1.12	0.90	0.59
LTE 13	5G NR-n2	Bottom for Laptop	0.52	0.55	0.00	0.00	0.00	0.00	0.00	0.00	1.07	1.07	1.07	1.07	1.07
		Lid Closed for Laptop	0.33	0.20	0.00	0.76	0.53	0.31	0.00	0.01	0.54	1.30	1.07	0.85	0.54
LTE 13	5G NR-n66	Bottom for Laptop	0.52	0.54	0.00	0.00	0.00	0.00	0.00	0.00	1.06	1.06	1.06	1.06	1.06
		Lid Closed for Laptop	0.33	0.22	0.00	0.76	0.53	0.31	0.00	0.01	0.56	1.32	1.09	0.87	0.56
LTE 30	5G NR-n5	Bottom for Laptop	0.60	0.58	0.00	0.00	0.00	0.00	0.00	0.00	1.18	1.18	1.18	1.18	1.18
		Lid Closed for Laptop	0.47	0.27	0.00	0.76	0.53	0.31	0.00	0.01	0.75	1.51	1.28	1.06	0.75
LTE 38	5G NR-n78	Bottom for Laptop	0.55	0.65	0.00	0.00	0.00	0.00	0.00	0.00	1.20	1.20	1.20	1.20	1.20
		Lid Closed for Laptop	0.43	0.39	0.00	0.76	0.53	0.31	0.00	0.01	0.83	1.59	1.36	1.14	0.83
LTE 40	5G NR-n41	Bottom for Laptop	0.57	0.63	0.00	0.00	0.00	0.00	0.00	0.00	1.20	1.20	1.20	1.20	1.20
		Lid Closed for Laptop	0.43	0.34	0.00	0.76	0.53	0.31	0.00	0.01	0.78	1.54	1.31	1.09	0.78
LTE 41	5G NR-n77	Bottom for Laptop	0.47	0.67	0.00	0.00	0.00	0.00	0.00	0.00	1.14	1.14	1.14	1.14	1.14
		Lid Closed for Laptop	0.37	0.38	0.00	0.76	0.53	0.31	0.00	0.01	0.76	1.52	1.29	1.07	0.76
LTE 48	5G NR-n5	Bottom for Laptop	0.34	0.58	0.00	0.00	0.00	0.00	0.00	0.00	0.92	0.92	0.92	0.92	0.92
		Lid Closed for Laptop	0.19	0.27	0.00	0.76	0.53	0.31	0.00	0.01	0.47	1.23	1.00	0.78	0.47
LTE 48	5G NR-n66	Bottom for Laptop	0.34	0.54	0.00	0.00	0.00	0.00	0.00	0.00	0.88	0.88	0.88	0.88	0.88
		Lid Closed for Laptop	0.19	0.22	0.00	0.76	0.53	0.31	0.00	0.01	0.42	1.18	0.95	0.73	0.42
LTE 66	5G NR-n5	Bottom for Laptop	0.62	0.58	0.00	0.00	0.00	0.00	0.00	0.00	1.20	1.20	1.20	1.20	1.20
		Lid Closed for Laptop	0.27	0.27	0.00	0.76	0.53	0.31	0.00	0.01	0.55	1.31	1.08	0.86	0.55
LTE 66	5G NR-n71	Bottom for Laptop	0.62	0.63	0.00	0.00	0.00	0.00	0.00	0.00	1.25	1.25	1.25	1.25	1.25
		Lid Closed for Laptop	0.27	0.34	0.00	0.76	0.53	0.31	0.00	0.01	0.62	1.38	1.15	0.93	0.62



## **Annex I. SAR to Peak Location Separation Ratio Analysis.**

Since sum of simultaneous transmission SAR is less than the SAR limit for Body : SAR<sub>1g</sub> 1.6 W/kg. There is no requirement for SAR to Peak Location Separation Ratio Analysis.

# Annex J. Calibration of Test Equipment List

Calibration of Test Equipment List are shown as below.

Equipment for SAR Test					
Equipment	Manufacturer	Model	SN	Cal. Date	Cal. Interval
System Validation Dipole	SPEAG	D750V3	1013	Aug. 31, 2021	1 Year
System Validation Dipole	SPEAG	D835V2	4d121	Aug. 31, 2021	1 Year
System Validation Dipole	SPEAG	D1750V2	1055	Sep. 02, 2021	1 Year
System Validation Dipole	SPEAG	D1900V2	5d036	Jan. 22, 2021	2 Year
System Validation Dipole	SPEAG	D2300V2	1004	Jan. 22, 2021	2 Year
System Validation Dipole	SPEAG	D2450V2	737	Aug. 26, 2021	1 Year
System Validation Dipole	SPEAG	D2600V2	1020	Aug. 17, 2021	1 Year
System Validation Dipole	SPEAG	D3500V2	1007	Jan. 19, 2021	2 Year
System Validation Dipole	SPEAG	D3700V2	1017	Aug. 19, 2021	1 Year
System Validation Dipole	SPEAG	D3900V2	1020	Mar. 21, 2021	2 Year
System Validation Dipole	SPEAG	D5GHzV2	1019	Mar. 19, 2021	2 Year
System Validation Dipole	SPEAG	D6.5GHzV2	1008	Sep. 24, 2021	1 Year
System Verification Source	SPEAG	5G Verification Source 10 GHz	1025	Jan. 17, 2022	1 Year
Dosimetric E-Field Probe	SPEAG	EX3DV4	3578	Jun. 23, 2021	1 Year
Dosimetric E-Field Probe	SPEAG	EX3DV4	3650	Mar. 24, 2022	1 Year
E-Field Probe	SPEAG	EUmmWV4	9438	Jul. 26, 2021	1 Year
Data Acquisition Electronics	SPEAG	DAE4	915	Jun. 22, 2021	1 Year
Data Acquisition Electronics	SPEAG	DAE4	1341	Aug. 20, 2021	1 Year
Universal Radio Communication Tester	Anritsu	MT8821C	6201381727	Aug. 24, 2021	1 Year
Universal Radio Communication Tester	Anritsu	MT8000A	6262012865	Nov. 30, 2021	1 Year
Spectrum Analyzer	R&S	FPH	103560	Jan. 28, 2022	1 Year
Analong Signal Generator	R&S	SMA100B	104417	Oct. 22, 2021	1 Year
Mini-Circuits Wideband Amplifier	Mini-Circuits	ZVA-183-S+	434502031A	Aug. 20, 2021	1 Year
Universal Wireless Test Set	Anritsu	MT8870A/MU887000A	6201699387	Sep. 22, 2021	1 Year
Thermometer	YFE	YF-160A	120702365	Aug. 06, 2021	1 Year
Dielectric Assessment Kit	SPEAG	DAKS-3.5	1151	Jul. 14, 2021	1 Year
Powersource1	SPEAG	SE_UMS_160 BA	4010	Jul. 13, 2021	1 Year

## Annex K. Considerations Related to Bluetooth for Setup and Testing

This device has installed Bluetooth engineering testing software which can provide continuous transmitting RF signal. During Bluetooth SAR testing, this device was operated to transmit continuously at the maximum transmission duty with specified transmission mode, operating frequency, lowest data rate, and maximum output power.

The Bluetooth call box has been used during SAR measurement and the EUT was set to DH5 mode at the maximum output power. Its duty factor was calculated as below and the measured SAR for Bluetooth would be scaled to the 100% transmission duty factor to determine compliance.

<Time-domain plot for Bluetooth transmission signal>

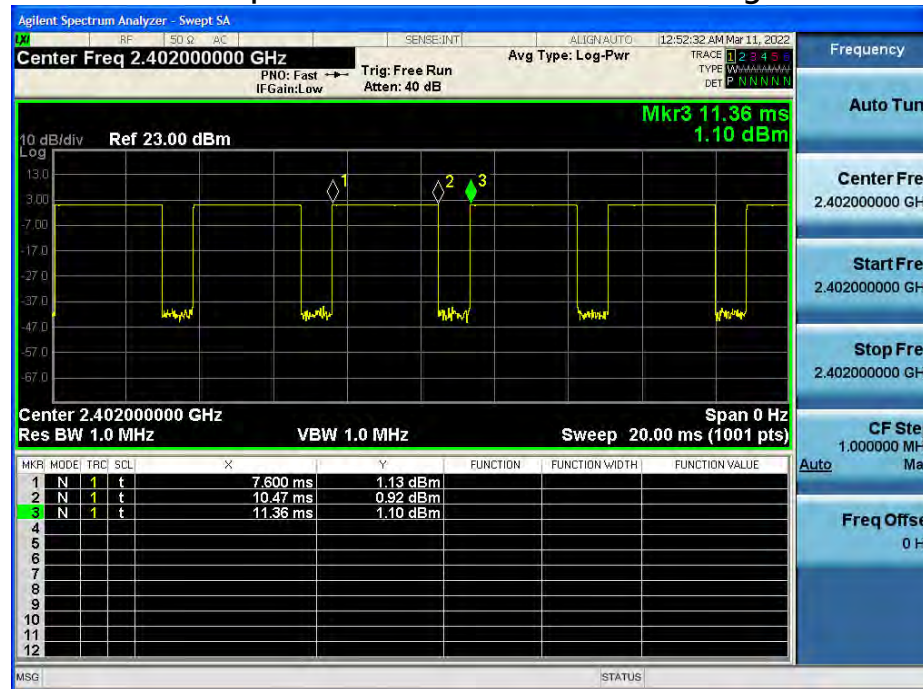

Time-domain plot for Bluetooth transmission signal

The duty factor of Bluetooth signal has been calculated as following.

$$\text{Duty Factor} = \text{Pulse Width} / \text{Total Period} = (10.47 - 7.6) / (11.36 - 7.6) = 76.33\%$$