

## Partial FCC Test Report

### (PART 22)

**Report No.:** RFBFLF-WTW-P22010014A

**Test Model:** B2502CB, B2502CBA, P2552CB, PX560CB, BW560CB, B2502FB,  
B2502FBA, P2552FB, PX560FB, BW560FB

(refer to item 3.1 for more details)

**Received Date:** Dec. 20, 2021

**Test Date:** Jun. 24 ~ Jun. 29, 2022

**Issued Date:** Jul. 05, 2022

**Applicant:** ASUSTeK COMPUTER INC.

**Address:** 1F., No. 15, Lide Rd., Beitou Dist., Taipei City 112, Taiwan

**Issued By:** Bureau Veritas Consumer Products Services (H.K.) Ltd., Taoyuan Branch  
Lin Kou Laboratories

**Lab Address:** No. 47-2, 14th Ling, Chia Pau Vil., Lin Kou Dist., New Taipei City, Taiwan

**Test Location:** No. 70, Wenming Rd., Guishan Dist., Taoyuan City 333, Taiwan (R.O.C.)

**FCC Registration /  
Designation Number:** 281270 / TW0032



This report is governed by, and incorporates by reference, the Conditions of Testing as posted at the date of issuance of this report at <http://www.bureauveritas.com/home/about-us/our-business/cps/about-us/terms-conditions/> and is intended for your exclusive use. Any copying or replication of this report to or for any other person or entity, or use of our name or trademark, is permitted only with our prior written permission. This report sets forth our findings solely with respect to the test samples identified herein. The results set forth in this report are not indicative or representative of the quality or characteristics of the lot from which a test sample was taken or any similar or identical product unless specifically and expressly noted. Our report includes all of the tests requested by you and the results thereof based upon the information that you provided to us. Measurement uncertainty is only provided upon request for accredited tests. Statements of conformity are based on simple acceptance criteria without taking measurement uncertainty into account, unless otherwise requested in writing. You have 60 days from date of issuance of this report to notify us of any material error or omission caused by our negligence or if you require measurement uncertainty; provided, however, that such notice shall be in writing and shall specifically address the issue you wish to raise. A failure to raise such issue within the prescribed time shall constitute your unqualified acceptance of the completeness of this report, the tests conducted and the correctness of the report contents.

## Table of Contents

<b>Release Control Record</b> .....	<b>3</b>
<b>1 Certificate of Conformity</b> .....	<b>4</b>
<b>2 Summary of Test Results</b> .....	<b>5</b>
2.1 Measurement Uncertainty .....	5
2.2 Test Site and Instruments .....	6
<b>3 General Information</b> .....	<b>7</b>
3.1 General Description of EUT .....	7
3.2 Configuration of System under Test.....	12
3.2.1 Description of Support Units .....	13
3.3 Test Mode Applicability and Tested Channel Detail .....	13
3.4 EUT Operating Conditions .....	14
3.5 General Description of Applied Standards and references.....	14
<b>4 Test Types and Results</b> .....	<b>15</b>
4.1 Radiated Emission Measurement.....	15
4.1.1 Limits of Radiated Emission Measurement .....	15
4.1.2 Test Procedure .....	15
4.1.3 Deviation from Test Standard .....	15
4.1.4 Test Setup.....	16
4.1.5 Test Results .....	17
<b>5 Pictures of Test Arrangements</b> .....	<b>27</b>
<b>Appendix – Information of the Testing Laboratories</b> .....	<b>28</b>

### Release Control Record

Issue No.	Description	Date Issued
RFBFLF-WTW-P22010014A	Original Release	Jul. 05, 2022



## 2 Summary of Test Results

Applied Standard: FCC Part 22 & Part 2			
FCC Clause	Test Item	Result	Remarks
2.1046 22.913 (a)	Effective Radiated Power	N/A	Refer to Note
2.1047	Modulation Characteristics	N/A	Refer to Note
22.913 (d)	Peak to Average Ratio	N/A	Refer to Note
2.1055 22.355	Frequency Stability	N/A	Refer to Note
2.1049	Occupied Bandwidth	N/A	Refer to Note
22.917	Band Edge Measurements	N/A	Refer to Note
2.1051 22.917	Conducted Spurious Emissions	N/A	Refer to Note
2.1053 22.917	Radiated Spurious Emissions	Pass	Meet the requirement of limit. Minimum passing margin is -36.22 dB at 265.71 MHz.

### Note:

1. This report is a partial report, only test items of Radiated Spurious Emissions tests was performed for this report. Other testing data please refer to Sporton report no.: FG051802A\_R01, FG051802B\_R01, FG051802G\_R01, FG051802H\_R01 for module (Brand: Fibocom, Model: FM350-GL).
2. Determining compliance based on the results of the compliance measurement, not taking into account measurement instrumentation uncertainty.

### 2.1 Measurement Uncertainty

Where relevant, the following measurement uncertainty levels have been estimated for tests performed on the EUT as specified in CISPR 16-4-2:

Measurement	Frequency	Expanded Uncertainty (k=2) ( $\pm$ )
Radiated Emissions up to 1 GHz	9kHz ~ 30MHz	3.00 dB
	30MHz ~ 200MHz	2.91 dB
	200MHz ~ 1000MHz	2.93 dB
Radiated Emissions above 1 GHz	1GHz ~ 18GHz	1.76 dB
	18GHz ~ 40GHz	1.77 dB

## 2.2 Test Site and Instruments

Description & Manufacturer	Model No.	Serial No.	Date of Calibration	Due Date of Calibration
Test Receiver Rohde & Schwarz	ESR3	102783	Dec. 20, 2021	Dec. 19, 2022
Spectrum Analyzer KEYSIGHT	N9020B	MY60110513	Dec. 24, 2021	Dec. 23, 2022
BILOG Antenna SCHWARZBECK	VULB9168	1214	Oct. 27, 2021	Oct. 26, 2022
HORN Antenna SCHWARZBECK	BBHA 9120 D	9120D-1170	Nov. 14, 2021	Nov. 13, 2022
HORN Antenna SCHWARZBECK	BBHA 9170	995	Nov. 14, 2021	Nov. 13, 2022
Loop Antenna EMCI	EM-6879	269	Sep. 16, 2021	Sep. 15, 2022
Loop Antenna TESEQ	HLA 6121	45745	Jul. 21, 2021	Jul. 20, 2022
Preamplifier EMCI	EMC330N	980798	Jan. 17, 2022	Jan. 16, 2023
Preamplifier EMCI	EMC118A45SE	980809	Dec. 30, 2021	Dec. 29, 2022
Preamplifier EMCI	EMC184045SE	980786	Jan. 17, 2022	Jan. 16, 2023
RF signal cable EMCI	EMC104-SM-SM- (9000+2000+1000)	201244+ 201232+ 210103	Jan. 17, 2022	Jan. 16, 2023
RF signal cable EMCI	EMCCFD400-NM- NM-(9000+300+500)	201251+ 201249+ 201248	Jan. 17, 2022	Jan. 16, 2023
RF signal cable EMCI	EMC101G-KM-KM- (5000+3000+2000)	201261+201258+2 01249	Jan. 17, 2022	Jan. 16, 2023
Software BV ADT	ADT_Radiated_V7.6. 15.9.5	NA	NA	NA
Antenna Tower Max-Full	MFA-515BSN	NA	NA	NA
Turn Table Max-Full	MFT-201SS	NA	NA	NA
Turn Table Controller Max-Full	MF-7802BS	MF780208676	NA	NA
USB Wideband Power Sensor KEYSIGHT	U2021XA	MY55050005/MY551 90004/MY55190007/ MY55210005	Jul. 12, 2021	Jul. 11, 2022
Radio Communication Test Station Anritsu	MT8000A	6262135011	Nov. 18, 2021	Nov. 17, 2022
Radio Communication Test Station Anritsu	MT8821C	6261806803	Feb. 16, 2022	Feb. 15, 2023

- Note: 1. The calibration interval of the above test instruments is 12 months and the calibrations are traceable to NML/ROC and NIST/USA.  
 2. The test was performed in WM Chamber 9.

### 3 General Information

#### 3.1 General Description of EUT

<b>Product</b>	Notebook PC/ExpertBook	
<b>Brand</b>	ASUS	
<b>Test Model</b>	B2502CB, B2502CBA, P2552CB, PX560CB, BW560CB, B2502FB, B2502FBA, P2552FB, PX560FB, BW560FB	
<b>Model Difference</b>	Refer to Note as below	
<b>Status of EUT</b>	Engineering Sample	
<b>Power Supply Rating</b>	11.4 Vdc (Battery) 5V/9V/15V/20V Vdc (Adapter)	
<b>Modulation Type</b>	WCDMA	QPSK
	LTE	QPSK, 16QAM, 64QAM, 256QAM
	5GNR	$\pi/2$ BPSK, QPSK, 16QAM, 64QAM, 256QAM
<b>Frequency Range</b>	WCDMA	826.4 ~ 846.6 MHz
	LTE 5 (Channel Bandwidth: 1.4 MHz)	824.7 ~ 848.3 MHz
	LTE 5 (Channel Bandwidth: 3 MHz)	825.5 ~ 847.5 MHz
	LTE 5 (Channel Bandwidth: 5 MHz)	826.5 ~ 846.5 MHz
	LTE 5 (Channel Bandwidth: 10 MHz)	829 ~ 844 MHz
	LTE 26 (Channel Bandwidth: 1.4 MHz)	824.7 ~ 848.3 MHz
	LTE 26 (Channel Bandwidth: 3 MHz)	825.5 ~ 847.5 MHz
	LTE 26 (Channel Bandwidth: 5 MHz)	826.5 ~ 846.5 MHz
	LTE 26 (Channel Bandwidth: 10 MHz)	829 ~ 844 MHz
	LTE 26 (Channel Bandwidth: 15 MHz)	831.5 ~ 841.5 MHz
	n5 (Channel Bandwidth 5MHz)	826.5MHz ~ 846.5MHz
	n5 (Channel Bandwidth 10MHz)	829.0MHz ~ 844.0MHz
	n5 (Channel Bandwidth 15MHz)	831.5MHz ~ 841.5MHz
	n5 (Channel Bandwidth 20MHz)	834.0MHz ~ 839.0MHz
<b>Antenna Type</b>	Refer to Note as below	
<b>Accessory Device</b>	Refer to Note as below	
<b>Data Cable Supplied</b>	Refer to Note as below	
<b>Tx / Rx Function</b>	1Tx / 4Rx	

Note:

1. All models are listed as below.

Brand	Model	Difference
ASUS	B2502CB	For marketing purpose
	B2502CBA	
	P2552CB	
	PX560CB	
	BW560CB	
	B2502FB	
	B2502FBA	
	P2552FB	
	PX560FB	
	BW560FB	

2. The EUT contains the following accessories.

Accessories information		
Main Board	Brand	ASUS
	Model	B2402FBA MB
LCD Panel 1	Brand	BOE
	Model	NT156WHM-N44
LCD Panel 2	spec	LCD 15.6' HD US EDP
	Brand	INNOLUX
LCD Panel 3	Model	N156BGA-EA3
	spec	LCD 15.6' HD US EDP
LCD Panel 4	Brand	BOE
	Model	NT156FHM-N62
LCD Panel 5	spec	LCD 15.6' FHD EDP
	Brand	INNOLUX
LCD Panel 6	Model	N156HGA-EA3
	spec	LCD 15.6' FHD EDP
LCD Panel 7	Brand	BOE
	Model	NE156FHM-N41
Camera 1	spec	LCD 15.6' FHD VWV EDP
	Brand	AUO
Camera 2	Model	B156HAN02.1
	spec	LCD 15.6' FHD VWV EDP
Camera 3	Brand	INNOLUX
	Model	N156HCE-EN1
Camera 4	spec	LCD 15.6' FHD WV US EDP 400NITS
	Brand	AZWAVE
CPU 1	Model	AM-9BF56EB-D
	spec	CAMERA HD RGB/IR ARRAY MIC CR
CPU 2	Brand	SUPREME
	Model	AHDFN050
CPU 3	spec	CAMERA HD FIX 3.3V ARRAYMIC CL
	Brand	AZWAVE
CPU 4	Model	AM-6SF56A2-J
	spec	CAMERA HD FIX 3.3V ARRAYMIC CL
CPU 5	Brand	SUPREME
	Model	AHDFN171
CPU 6	spec	CAMERA HD FIX 3.3V ARRAYMIC CL
	Brand	Intel/BGA1744
CPU 7	Model	I7-1260P 12C
	spec	2.1G
CPU 8	Brand	Intel/BGA1744
	Model	I5-1240P 12C
CPU 9	spec	1.7G
	Brand	Intel/BGA1744
CPU 10	Model	I3-1215U 6C
	spec	1.2GHz



Accessories information		
V-Pro CPU 1	Brand	Intel/BGA1744
	Model	I5-1250P
	spec	1.7GHz
V-Pro CPU 2	Brand	Intel/BGA1744
	Model	I7-1270P
	spec	2.2GHz
M.2 SSD 1	Brand	WD
	Model	SDBPNPZ-256G-1002
	spec	256GB M2 2280 NVME
M.2 SSD 2	Brand	KST
	Model	OM8PDP3256B-AB1
	spec	256GB M2 2280 NVME
M.2 SSD 3	Brand	INT
	Model	SSDPEKNU512GZ
	spec	512GB M2 2280 NVME
M.2 SSD 4	Brand	MICRON
	Model	MTFDHBA512QFD
	spec	512G M2 2280 NVME
.2 SSD 5	Brand	INT
	Model	SSDPEKNU010TZ
	spec	1TB M2 2280 NVME
M.2 SSD 6	Brand	MICRON
	Model	MTFDHBA1T0QFD
	spec	1TB M2 2280 NVME
M.2 SSD 7	Brand	SAMSUNG
	Model	MZVL2512HCJQ
	spec	512GB M2 2280 NVME
M.2 SSD 8	Brand	MICRON
	Model	MTFDKBA512TFH
	spec	512GB M2 2280 NVME
M.2 SSD 9	Brand	SAMSUNG
	Model	MZVL21T0HCLR
	spec	1TB M2 2280 NVME
M.2 SSD 10	Brand	MICRON
	Model	MTFDKBA1T0TFH
	spec	1TB M2 2280 NVME
M.2 SSD 11	Brand	SAMSUNG
	Model	MZVL22T0HBLB
	spec	2TB M2 2280 NVME
M.2 SSD 12	Brand	MICRON
	Model	MTFDKBA2T0TFH
	spec	2TB M2 2280 NVME
HDD 1	Brand	TOSHIBA
	Model	MQ04ABF100
	spec	1 TB-5400rpm
HDD 2	Brand	SEAGATE
	Model	ST1000LM035
	spec	1 TB-5400rpm
HDD 3	Brand	SEAGATE
	Model	ST1000LM049
	spec	1 TB-7200rpm
HDD 4	Brand	SEAGATE
	Model	ST2000LM007
	spec	2 TB-5400rpm
BT/WLAN Module	Brand	INTEL
	Model	AX211D2W
WWAN Module	Brand	Fibocom
	Model	FM350-GL
Battery 1	Brand	ASUS
	Model	B31N1909
	Power Rating Manufacturer	CPT/GLP606080R/3S1P/11.4V/48WH CPT
SO-DIMM	SPEC	DDR4, 3200 MHz (4G/8G/16G/32G)

Accessories information		
AC Adapter 1	Brand	ASUS
	Model	AD10380
	AC Input	100 - 240 Vac; 50 - 60 Hz; 1.5 A
	DC Output	5Vdc; 3A / 9Vdc; 3A / 15Vdc; 3A / 20Vdc; 3.25A
	DC Output Cable	1.5m / 0 core shielding
AC Adapter 2	Brand	PI
	Model	ASUS
	AC Input	A19-065N3A
	DC Output	100 - 240 Vac; 50 - 60 Hz; 1.5 A
	DC Output Cable	5Vdc; 3A / 9Vdc; 3A / 15Vdc; 3A / 20Vdc; 3.25A
AC power cable	Manufacturer	1.5m / 0 core shielding
	Signal Line	0.8 meter / no shielding/ o core
AC Adapter 3	Brand	ASUS
	Model	ADP-65TW A
	AC Input	100 - 240 Vac; 50 - 60 Hz; 1.5 A
	DC Output	5Vdc; 3A / 9Vdc; 3A / 15Vdc; 3A / 20Vdc; 3.25A
Type C to Type C USB Cable 1	Manufacturer	DELTA
	Brand	MECIMEX
	Model	USB2.0 TYPE C TO C CABLE
Stylus Pen	Signal Line	1.5 meter
	Brand	Shenzhen qianfenyi intelligent technology co., LTD.
	Model	Active Stylus SA201H
	Manufacturer	MAXEYE

\*\*After pretesting, Adapter 1 was the worst case and chosen for final test.

3. The antenna information is listed as below.

Ant. Type	Brand	Model
PIFA	PULSE	Ant. 0: TZ21131 (1415-08YT0A9)
		Ant. 1: TZ21134 (1415-08YQ0A9)
		Ant. 2: TZ21138 (1415-08YR0A9)
		Ant. 3: TZ21139 (1415-08YS0A9)

Band	WCDMA			LTE																	
	II	IV	V	2	4	5	7	12	13	14	17	25	26	30	38	41	48	66	71		
Peak Gain (dBi)	NB	Ant. 0	2.1	2.33	-0.74	2.1	2.33	-0.74	1.7	0.8	1.49	1.54	0.77	2.1	0.22	3.38	2.42	2.68	1.78	2.47	1.03
		Ant. 1	0.23	2.96	-0.07	0.23	2.96	-0.07	2.72	-	0.6	0.36	-	0.23	-0.07	3.9	3.13	3.22	2.21	2.96	-
		Ant. 2	3.33	-	-	3.33	-	-	4.24	-	-	-	-	3.33	-	1.35	3.59	4.93	5.07	-	-
		Ant. 3	2.44	1.52	-	2.44	1.52	-	2.31	-	-	-	-	2.44	-	1.1	1.93	2.31	2.67	1.52	-
	TB	Ant. 0	2.21	1.35	-3.19	2.21	1.35	-3.19	0.73	-2.15	-3.91	-4.53	-2.21	2.25	-3.19	2.85	0.98	2.18	6.67	1.35	-1.81
		Ant. 1	0.35	-0.29	-3.13	0.35	-0.29	-3.13	3.92	-	-6.59	-4.41	-	0.35	-3.13	0.99	3.92	3.96	4.89	-0.29	-
		Ant. 2	1.65	-	-	1.65	-	-	2.36	-	-	-	-	1.65	-	1.42	2.25	2.86	7.94	-	-
	Ant. 3	0.79	-0.12	-	0.79	-0.12	-	0.18	-	-	-	-	1.7	-	4.16	-0.64	0.28	3.05	-0.12	-	

Band			5G NR										
			2	5	7	25	30	38	41	66	71	77	78
Peak Gain (dBi)	NB	Ant. 0	2.1	-0.74	1.7	2.1	3.38	2.42	2.68	2.47	1.03	1.78	1.08
		Ant. 1	0.23	-0.07	2.72	0.23	3.9	3.13	3.22	2.96	-	2.6	5.38
		Ant. 2	3.33	-	4.24	3.33	1.35	3.59	4.93	-	-	5.07	5.8
		Ant. 3	2.44	-	2.31	2.44	1.1	1.93	2.31	1.52	-	3.36	2.62
	TB	Ant. 0	2.21	-3.19	0.73	2.25	2.85	0.98	2.18	1.35	-1.81	7.8	6.92
		Ant. 1	0.35	-3.13	3.92	0.35	0.99	3.92	3.96	-0.29	-	5.34	4.23
		Ant. 2	1.65	-	2.36	1.65	1.42	2.25	2.86	-	-	7.94	7.55
		Ant. 3	0.79	-	0.18	1.7	4.16	-0.64	0.28	-0.12	-	4.28	2.35

4. The above Antenna information refers to the manufacturer's antenna specifications, the laboratory shall not be held responsible.
5. The above EUT information is declared by manufacturer and for more detailed features description, please refers to the manufacturer's specifications or user's manual.
6. The EUT contains certified WWAN module with FCC ID: MSQFM350GL.

### 3.2 Configuration of System under Test

#### <Radiated Emission Test>

#### WCDMA & LTE

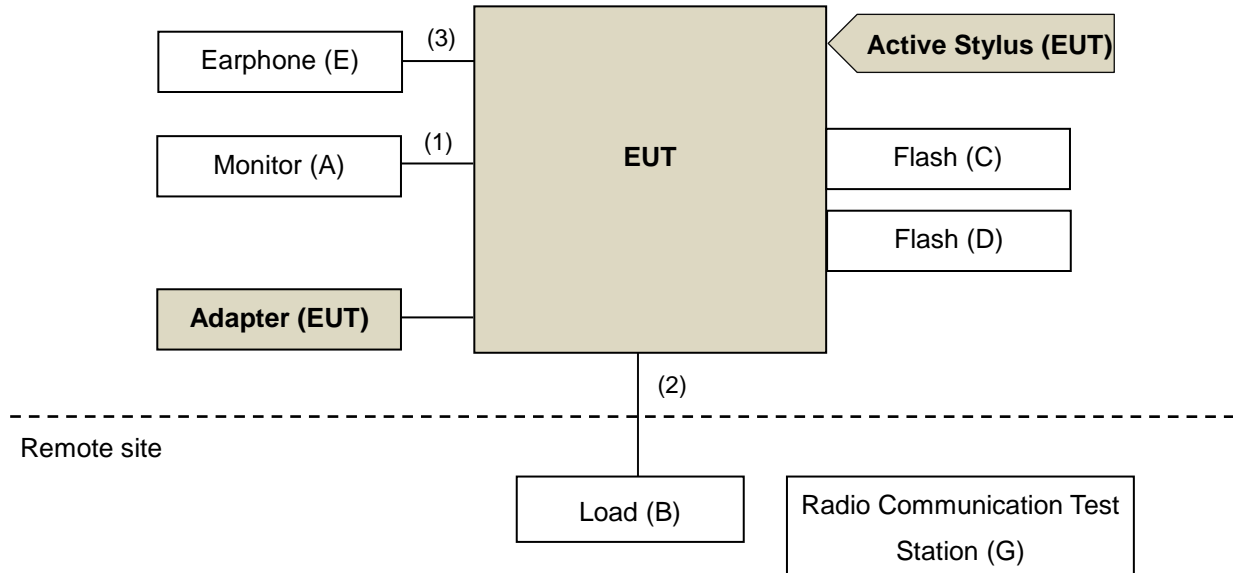

#### 5GNR

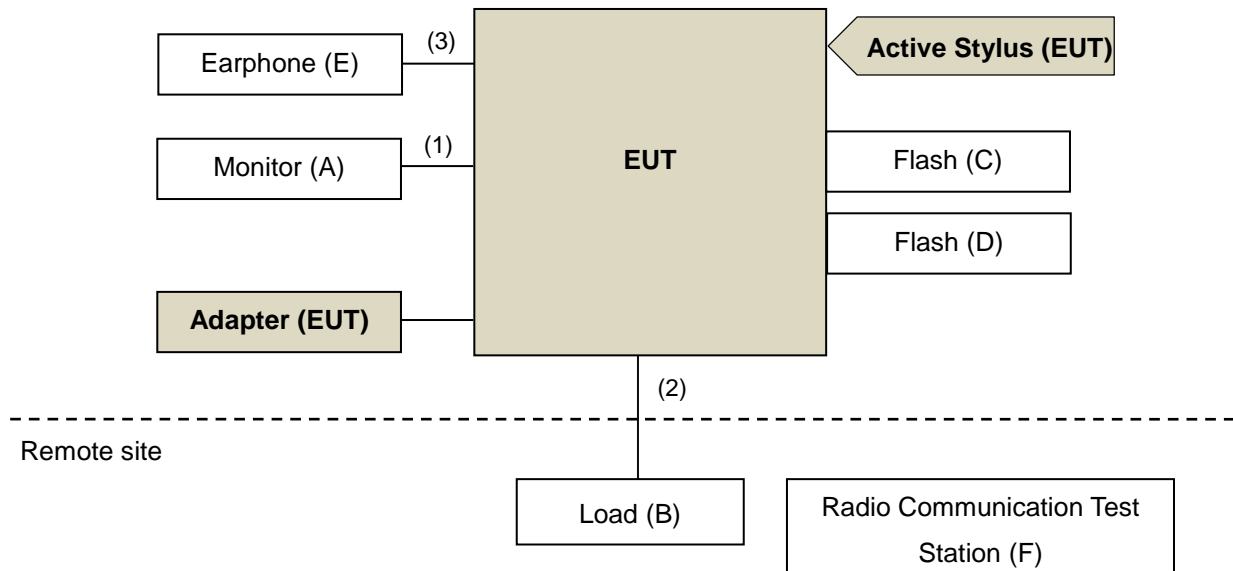

### 3.2.1 Description of Support Units

The EUT has been tested as an independent unit together with other necessary accessories or support units. The following support units or accessories were used to form a representative test configuration during the tests.

No.	Product	Brand	Model No.	Serial No.	FCC ID
A	Monitor	ASUS	VP247	N/A	N/A
B	Load	N/A	N/A	N/A	N/A
C	Flash	HP	v250W	05	N/A
D	Flash	SanDisk	SDDDC3-032G	N/A	N/A
E	Earphone	Apple	MB77PFEB	N/A	N/A
F	Radio Communication Test Station	Anritsu	MT8000A	6262135011	N/A
G	Radio Communication Test Station	Anritsu	MT8821C	6261806803	N/A

No.	Signal Cable Description of The Above Support Units
1.	HDMI Cable: 2m
2.	LAN Cable: 1.5m
3.	Audio Cable: 1.6m

Note:

1. All power cords of the above support units are non-shielded (1.8m).

### 3.3 Test Mode Applicability and Tested Channel Detail

Pre-Scan has been conducted to determine the worst-case mode from all possible combinations between available modulations, data rates, XYZ axis, and antenna ports.

The worst case was found when positioned on X-plane. Following channel(s) was (were) selected for the final test as listed below:

#### WCDMA

EUT Configure Mode	Test Item	Available Channel	Tested Channel	Mode
-	Radiated Emission	4132 to 4233	4233	WCDMA

#### LTE Band 5

EUT Configure Mode	Test Item	Available Channel	Tested Channel	Channel Bandwidth	Modulation	Mode
-	Radiated Emission	20450 to 20600	20450	10 MHz	QPSK	1 RB / 0 RB Offset

### LTE Band 26

EUT Configure Mode	Test Item	Available Channel	Tested Channel	Channel Bandwidth	Modulation	Mode
-	Radiated Emission	26865 to 26965	26915	15 MHz	QPSK	1 RB / 0 RB Offset

### 5G NR Band 5

EUT Configure Mode	Test Item	Available Channel	Tested Channel	Channel Bandwidth	Modulation	Mode
-	Radiated Emission	166800 to 167800	167300	20MHz	QPSK	1 RB / 1 RB Offset

### Test Condition:

Test Item	Environmental Conditions	Input Power	Tested By
Radiated Emission	22 deg. C, 67 % RH	120 Vac, 60 Hz	Edison Lee, Wade Huang

### 3.4 EUT Operating Conditions

The EUT makes a call to the communication simulator. The communication simulator station system controlled a EUT to export maximum output power under transmission mode and specific channel frequency.

### 3.5 General Description of Applied Standards and references

The EUT is a RF Product. According to the specifications of the manufacturer, it must comply with the requirements of the following standards and references:

#### Test Standard:

**FCC 47 CFR Part 2**

**FCC 47 CFR Part 22**

**ANSI 63.26-2015**

**Note:** All test items have been performed and recorded as per the above standards.

#### References Test Guidance:

**KDB 971168 D01 Power Meas License Digital Systems v03r01**

**ANSI/TIA/EIA-603-E 2016**

**Note:** All test items have been performed as a reference to the above KDB test guidance.

## 4 Test Types and Results

### 4.1 Radiated Emission Measurement

#### 4.1.1 Limits of Radiated Emission Measurement

The power of any emission outside of the authorized operating frequency ranges must be attenuated below the transmitting power (P) by a factor of at least  $43 + 10 \log(P)$  dB. The emission limit is equal to -13 dBm.

#### 4.1.2 Test Procedure

- a. In the semi-anechoic chamber, EUT placed on the 0.8m(below or equal 1GHz) and/or 1.5m(above 1GHz) height of Turn Table, rotated the table around 360 degrees to search the maximum radiation power and receiver antenna shall be rotated vertical and horizontal polarization and moved height from 1m to 4m to find the maximum polar radiated power. The "Read Value" is the spectrum reading the maximum power value.
- b. The height of antenna is varied from one meter to four meters above the ground to determine the maximum value of the field strength. Both horizontal and vertical polarizations of the antenna are set to make the measurement.
- c. Perform a field strength measurement and record the worse read value, is the field strength value via a spectrum reading obtained corrected for antenna factor, cable loss and pre-amplifier factor and then mathematically convert the measured field strength level to EIRP/ERP level.
- d. Following C63.26 section 5.5 and 5.2.7  
EIRP (dBm) =  $E \text{ (dB}\mu\text{V/m)} + 20\log(D) - 104.8$ ; where D is the measurement distance (in the far field region) in m.  
ERP (dBm) =  $E \text{ (dB}\mu\text{V/m)} + 20\log(D) - 104.8 - 2.15$ ; where D is the measurement distance (in the far field region) in m.

#### NOTE:

1. The resolution bandwidth and video bandwidth of test receiver/spectrum analyzer is 1 MHz/3 MHz.
2. The emission levels were against the limit of frequency range 9 kHz ~ 30 MHz:

The amplitude of spurious emissions attenuated more than 20 dB below the permissible value is not required to be report.

#### 4.1.3 Deviation from Test Standard

No deviation.

4.1.4 Test Setup

<Radiated Emission below or equal 1 GHz>

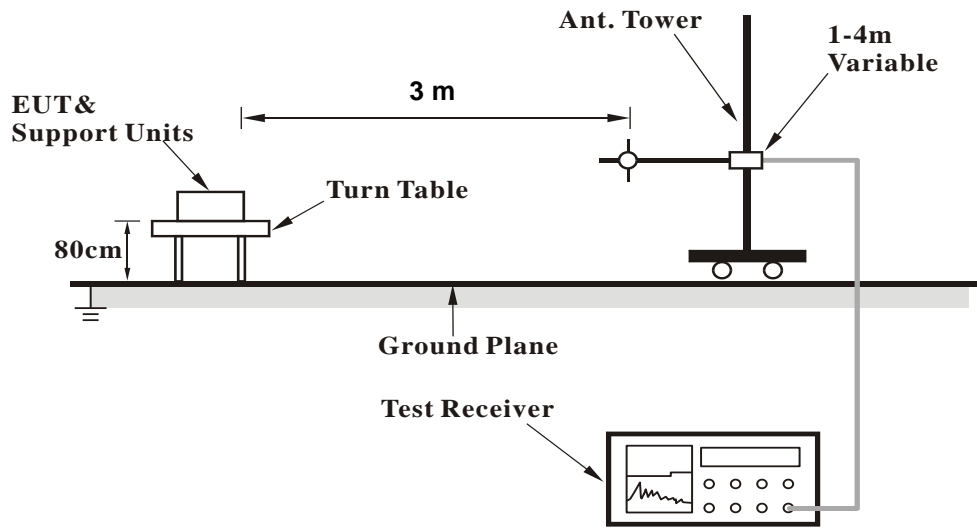

<Radiated Emission above 1 GHz>

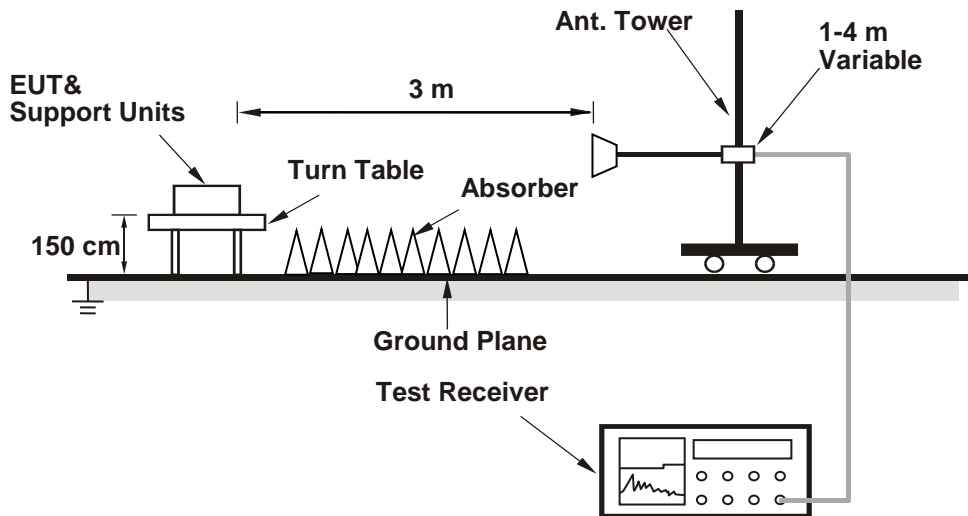

For the actual test configuration, please refer to the attached file (Test Setup Photo).



#### 4.1.5 Test Results

Below 1GHz

WCDMA Band 5

<b>RF Mode</b>	TX WCDMA Band V	<b>Channel</b>	CH 4233 : 846.6 MHz
<b>Frequency Range</b>	30MHz ~ 1GHz		

Antenna Polarity & Test Distance : Horizontal at 3 m								
No	Frequency (MHz)	ERP (dBm)	Limit (dBm)	Margin (dB)	Antenna Height (m)	Table Angle (Degree)	Raw Value (dBuV)	Correction Factor (dB/m)
1	144.46	-55.72	-13.00	-42.72	1.50 H	272	55.02	-110.74
2	203.63	-57.74	-13.00	-44.74	1.50 H	185	56.59	-114.33
3	328.76	-60.38	-13.00	-47.38	1.01 H	272	49.06	-109.44
4	371.44	-60.09	-13.00	-47.09	1.01 H	323	48.42	-108.51
5	511.12	-63.36	-13.00	-50.36	2.00 H	123	41.95	-105.31
6	604.24	-61.73	-13.00	-48.73	1.01 H	260	41.49	-103.22

**Remarks:**

1.  $ERP(dBm) = Raw\ Value(dBuV) + Correction\ Factor(dB/m)$
2.  $Correction\ Factor(dB/m) = Antenna\ Factor(dB/m) + Cable\ Factor(dB) - Pre-Amplifier\ Factor(dB) + 20\log(D) - 104.8 - 2.15$
3.  $Margin\ value = ERP - Limit\ value$
4. The other ERP levels were very low against the limit.

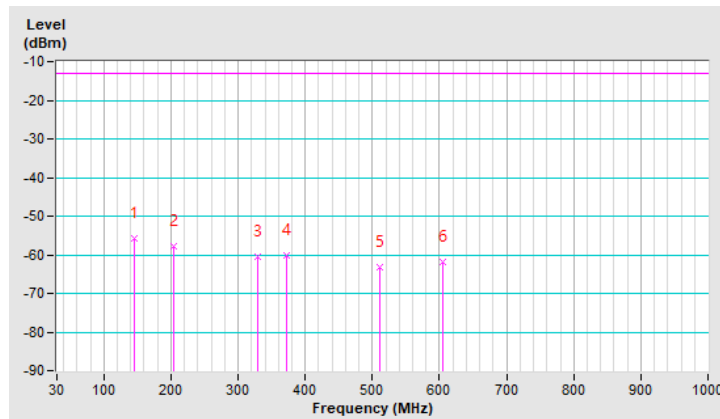

<b>RF Mode</b>	TX WCDMA Band V	<b>Channel</b>	CH 4233 : 846.6 MHz
<b>Frequency Range</b>	30MHz ~ 1GHz		

Antenna Polarity & Test Distance : Vertical at 3 m								
No	Frequency (MHz)	ERP (dBm)	Limit (dBm)	Margin (dB)	Antenna Height (m)	Table Angle (Degree)	Raw Value (dBuV)	Correction Factor (dB/m)
1	56.19	-53.11	-13.00	-40.11	1.01 V	229	57.77	-110.88
2	143.49	-55.79	-13.00	-42.79	1.01 V	229	55.02	-110.81
3	241.46	-62.08	-13.00	-49.08	1.01 V	91	50.35	-112.43
4	344.28	-60.68	-13.00	-47.68	1.50 V	246	48.65	-109.33
5	453.89	-63.01	-13.00	-50.01	2.00 V	216	43.30	-106.31
6	524.70	-62.21	-13.00	-49.21	1.01 V	2	42.82	-105.03

**Remarks:**

1.  $ERP(dBm) = Raw\ Value(dBuV) + Correction\ Factor(dB/m)$
2.  $Correction\ Factor(dB/m) = Antenna\ Factor(dB/m) + Cable\ Factor(dB) - Pre-Amplifier\ Factor(dB) + 20\log(D) - 104.8 - 2.15$
3.  $Margin\ value = ERP - Limit\ value$
4. The other ERP levels were very low against the limit.

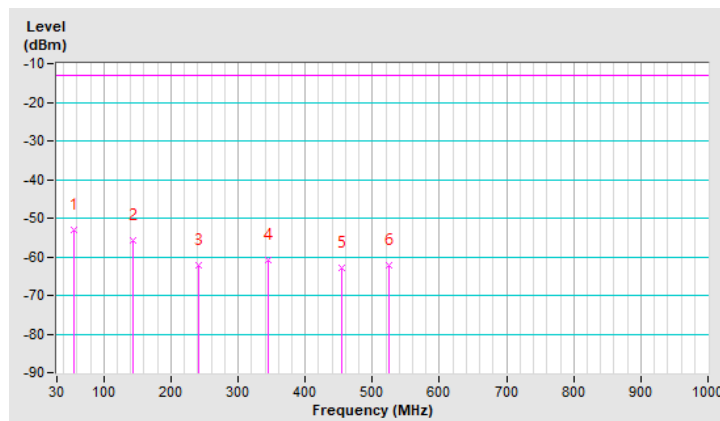

LTE Band 5, Channel Bandwidth: 10MHz

<b>RF Mode</b>	TX LTE Band V-10MHz	<b>Channel</b>	CH 20450 : 829.0 MHz
<b>Frequency Range</b>	30MHz ~ 1GHz		

Antenna Polarity & Test Distance : Horizontal at 3 m								
No	Frequency (MHz)	ERP (dBm)	Limit (dBm)	Margin (dB)	Antenna Height (m)	Table Angle (Degree)	Raw Value (dBuV)	Correction Factor (dB/m)
1	45.52	-66.55	-13.00	-53.55	1.01 H	263	44.10	-110.65
2	108.57	-66.46	-13.00	-53.46	1.01 H	142	47.38	-113.84
3	230.79	-58.91	-13.00	-45.91	1.01 H	181	54.39	-113.30
4	295.78	-66.78	-13.00	-53.78	2.00 H	202	43.79	-110.57
5	342.34	-64.00	-13.00	-51.00	1.49 H	308	45.31	-109.31
6	467.47	-66.80	-13.00	-53.80	1.01 H	2	39.39	-106.19

**Remarks:**

1.  $ERP(dBm) = Raw\ Value(dBuV) + Correction\ Factor(dB/m)$
2.  $Correction\ Factor(dB/m) = Antenna\ Factor(dB/m) + Cable\ Factor(dB) - Pre-Amplifier\ Factor(dB) + 20\log(D) - 104.8 - 2.15$
3.  $Margin\ value = ERP - Limit\ value$
4. The other ERP levels were very low against the limit.

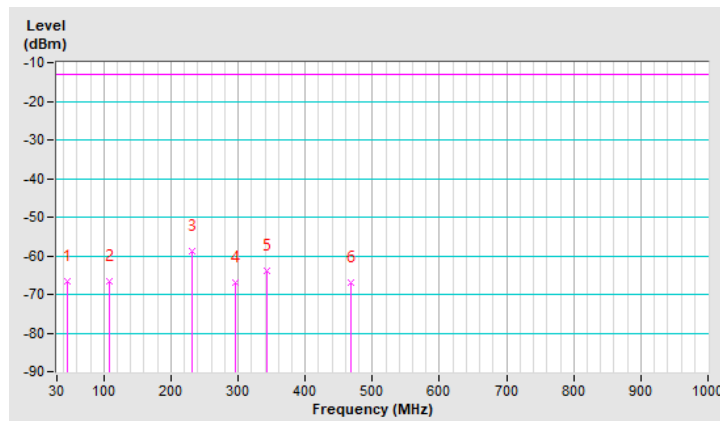

<b>RF Mode</b>	TX LTE Band V-10MHz	<b>Channel</b>	CH 20450 : 829.0 MHz
<b>Frequency Range</b>	30MHz ~ 1GHz		

Antenna Polarity & Test Distance : Vertical at 3 m								
No	Frequency (MHz)	ERP (dBm)	Limit (dBm)	Margin (dB)	Antenna Height (m)	Table Angle (Degree)	Raw Value (dBUV)	Correction Factor (dB/m)
1	57.16	-58.22	-13.00	-45.22	1.50 V	216	52.99	-111.21
2	156.10	-63.76	-13.00	-50.76	1.01 V	16	46.85	-110.61
3	249.22	-66.69	-13.00	-53.69	1.50 V	102	45.47	-112.16
4	371.44	-65.17	-13.00	-52.17	1.01 V	231	43.34	-108.51
5	524.70	-66.12	-13.00	-53.12	2.00 V	2	38.91	-105.03
6	681.84	-62.70	-13.00	-49.70	2.00 V	213	39.37	-102.07

**Remarks:**

1.  $ERP(dBm) = Raw\ Value(dBuV) + Correction\ Factor(dB/m)$
2.  $Correction\ Factor(dB/m) = Antenna\ Factor(dB/m) + Cable\ Factor(dB) - Pre-Amplifier\ Factor(dB) + 20\log(D) - 104.8 - 2.15$
3.  $Margin\ value = ERP - Limit\ value$
4. The other ERP levels were very low against the limit.

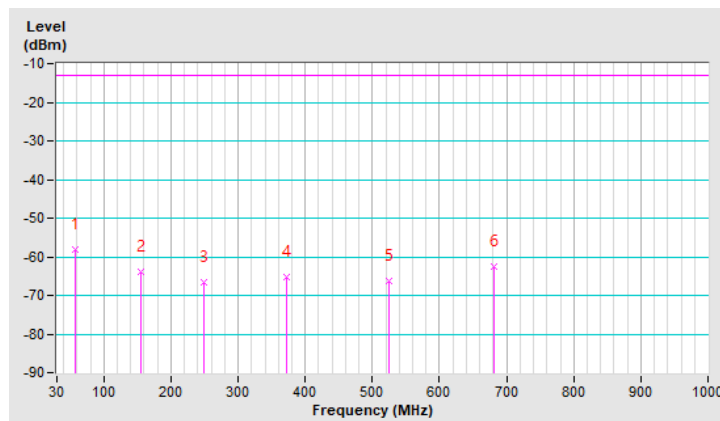

LTE Band 26, Channel Bandwidth: 15MHz

<b>RF Mode</b>	TX LTE Band XXVI-15MHz	<b>Channel</b>	CH 26915 : 836.5 MHz
<b>Frequency Range</b>	30MHz ~ 1GHz		

Antenna Polarity & Test Distance : Horizontal at 3 m								
No	Frequency (MHz)	ERP (dBm)	Limit (dBm)	Margin (dB)	Antenna Height (m)	Table Angle (Degree)	Raw Value (dBuV)	Correction Factor (dB/m)
1	60.07	-71.21	-13.00	-58.21	1.50 H	30	43.79	-115.00
2	156.10	-66.70	-13.00	-53.70	1.01 H	181	47.43	-114.13
3	244.37	-61.21	-13.00	-48.21	1.01 H	187	54.62	-115.83
4	403.45	-71.19	-13.00	-58.19	1.01 H	15	40.12	-111.31
5	502.39	-69.31	-13.00	-56.31	2.00 H	2	39.77	-109.08
6	612.97	-66.39	-13.00	-53.39	1.01 H	51	40.15	-106.54

**Remarks:**

1.  $ERP(dBm) = Raw\ Value(dBuV) + Correction\ Factor(dB/m)$
2.  $Correction\ Factor(dB/m) = Antenna\ Factor(dB/m) + Cable\ Factor(dB) - Pre-Amplifier\ Factor(dB) + 20\log(D) - 104.8 - 2.15$
3.  $Margin\ value = ERP - Limit\ value$
4. The other ERP levels were very low against the limit.

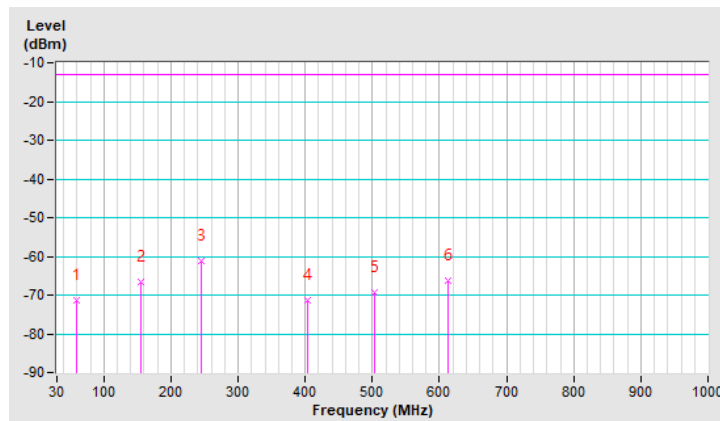

<b>RF Mode</b>	TX LTE Band XXVI-15MHz	<b>Channel</b>	CH 26915 : 836.5 MHz
<b>Frequency Range</b>	30MHz ~ 1GHz		

Antenna Polarity & Test Distance : Vertical at 3 m								
No	Frequency (MHz)	ERP (dBm)	Limit (dBm)	Margin (dB)	Antenna Height (m)	Table Angle (Degree)	Raw Value (dBuV)	Correction Factor (dB/m)
1	103.72	-59.19	-13.00	-46.19	1.00 V	172	55.34	-114.53
2	136.70	-57.31	-13.00	-44.31	1.00 V	233	53.97	-111.28
3	236.61	-63.90	-13.00	-50.90	1.50 V	95	48.81	-112.71
4	269.59	-65.99	-13.00	-52.99	2.00 V	5	45.32	-111.31
5	345.25	-64.14	-13.00	-51.14	1.50 V	250	45.21	-109.35
6	371.44	-62.81	-13.00	-49.81	1.00 V	347	45.70	-108.51

**Remarks:**

1.  $ERP(dBm) = Raw\ Value(dBuV) + Correction\ Factor(dB/m)$
2.  $Correction\ Factor(dB/m) = Antenna\ Factor(dB/m) + Cable\ Factor(dB) - Pre-Amplifier\ Factor(dB) + 20\log(D) - 104.8 - 2.15$
3.  $Margin\ value = ERP - Limit\ value$
4. The other ERP levels were very low against the limit.

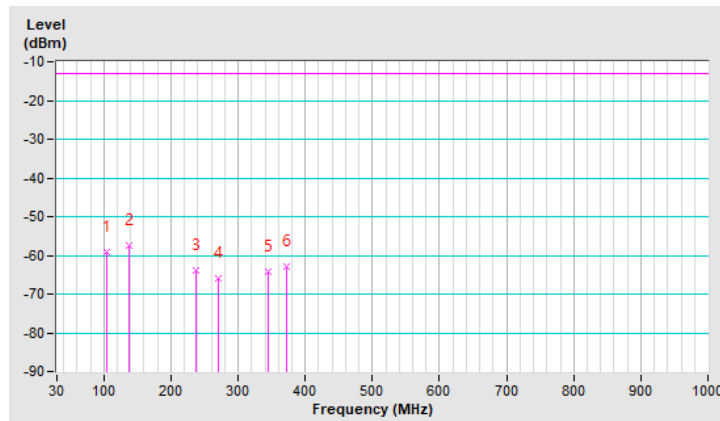

n5, Channel Bandwidth 20MHz

<b>RF Mode</b>	TX 5G NR Band V-20MHz	<b>Channel</b>	CH 167300 : 836.5 MHz
<b>Frequency Range</b>	30MHz ~ 1GHz		

Antenna Polarity & Test Distance : Horizontal at 3 m								
No	Frequency (MHz)	ERP (dBm)	Limit (dBm)	Margin (dB)	Antenna Height (m)	Table Angle (Degree)	Raw Value (dBuV)	Correction Factor (dB/m)
1	202.66	-55.18	-13.00	-42.18	1.99 H	2	59.13	-114.31
2	265.71	-49.22	-13.00	-36.22	1.99 H	314	62.32	-111.54
3	318.09	-52.56	-13.00	-39.56	1.01 H	144	57.29	-109.85
4	367.56	-56.99	-13.00	-43.99	1.01 H	144	51.67	-108.66
5	444.19	-59.14	-13.00	-46.14	1.99 H	5	47.36	-106.50
6	555.74	-64.67	-13.00	-51.67	1.49 H	209	39.80	-104.47

**Remarks:**

1. ERP(dBm) = Raw Value(dBuV) + Correction Factor(dB/m)
2. Correction Factor(dB/m) = Antenna Factor(dB/m) + Cable Factor(dB) – Pre-Amplifier Factor(dB) + 20log(D) – 104.8 – 2.15
3. Margin value = ERP – Limit value
4. The other ERP levels were very low against the limit.

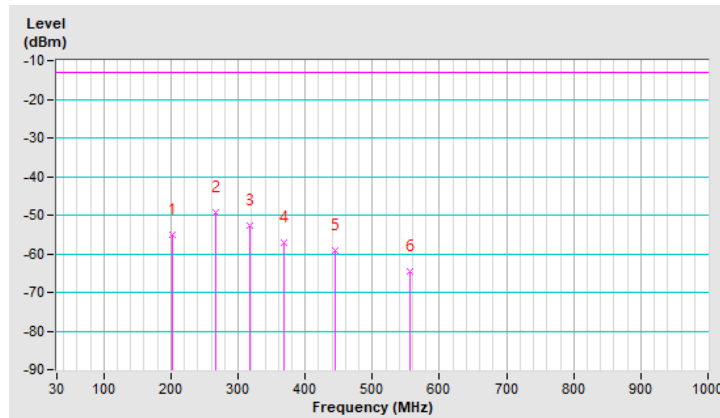

<b>RF Mode</b>	TX 5GNR Band V-20MHz	<b>Channel</b>	CH 167300 : 836.5 MHz
<b>Frequency Range</b>	30MHz ~ 1GHz		

Antenna Polarity & Test Distance : Vertical at 3 m								
No	Frequency (MHz)	ERP (dBm)	Limit (dBm)	Margin (dB)	Antenna Height (m)	Table Angle (Degree)	Raw Value (dBuV)	Correction Factor (dB/m)
1	186.17	-55.45	-13.00	-42.45	1.99 V	325	57.45	-112.90
2	238.55	-56.82	-13.00	-43.82	1.51 V	16	55.77	-112.59
3	332.64	-54.39	-13.00	-41.39	1.51 V	162	54.95	-109.34
4	419.94	-56.77	-13.00	-43.77	1.01 V	343	50.55	-107.32
5	522.76	-56.44	-13.00	-43.44	1.51 V	331	48.63	-105.07
6	656.62	-61.47	-13.00	-48.47	1.51 V	2	41.02	-102.49

**Remarks:**

1. ERP(dBm) = Raw Value(dBuV) + Correction Factor(dB/m)
2. Correction Factor(dB/m) = Antenna Factor(dB/m) + Cable Factor(dB) – Pre-Amplifier Factor(dB) + 20log(D) – 104.8 – 2.15
3. Margin value = ERP – Limit value
4. The other ERP levels were very low against the limit.

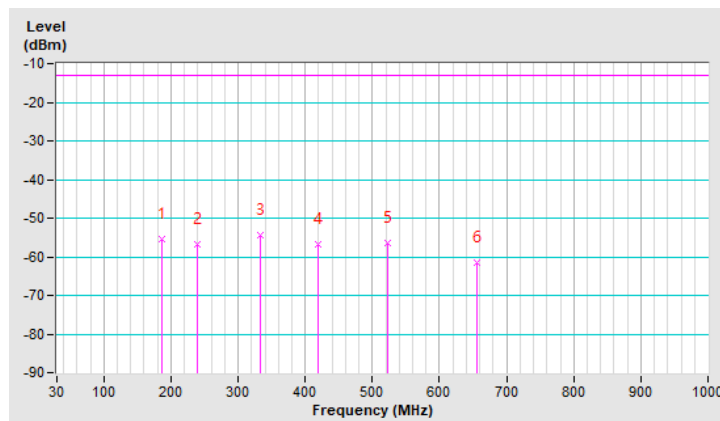



Above 1GHz  
 WCDMA Band 5

<b>RF Mode</b>	TX WCDMA Band V	<b>Channel</b>	CH 4233 : 846.6 MHz
<b>Frequency Range</b>	1GHz ~ 18GHz		

Antenna Polarity & Test Distance : Horizontal at 3 m								
No	Frequency (MHz)	ERP (dBm)	Limit (dBm)	Margin (dB)	Antenna Height (m)	Table Angle (Degree)	Raw Value (dBuV)	Correction Factor (dB/m)
1	1693.20	-59.41	-13.00	-46.41	1.77 H	109	46.06	-105.47
Antenna Polarity & Test Distance : Vertical at 3 m								
No	Frequency (MHz)	ERP (dBm)	Limit (dBm)	Margin (dB)	Antenna Height (m)	Table Angle (Degree)	Raw Value (dBuV)	Correction Factor (dB/m)
1	1693.20	-59.58	-13.00	-46.58	1.24 V	68	45.89	-105.47

**Remarks:**

1. ERP(dBm) = Raw Value(dBuV) + Correction Factor(dB/m)
2. Correction Factor(dB/m) = Antenna Factor(dB/m) + Cable Factor(dB) – Pre-Amplifier Factor(dB) + 20log(D) – 104.8 – 2.15
3. Margin value = ERP – Limit value
4. The other ERP levels were very low against the limit.

LTE Band 5

<b>RF Mode</b>	TX LTE Band V-10MHz	<b>Channel</b>	CH 20450 : 829.0 MHz
<b>Frequency Range</b>	1GHz ~ 18GHz		

Antenna Polarity & Test Distance : Horizontal at 3 m								
No	Frequency (MHz)	ERP (dBm)	Limit (dBm)	Margin (dB)	Antenna Height (m)	Table Angle (Degree)	Raw Value (dBuV)	Correction Factor (dB/m)
1	1658.00	-58.83	-13.00	-45.83	2.10 H	67	46.62	-105.45
Antenna Polarity & Test Distance : Vertical at 3 m								
No	Frequency (MHz)	ERP (dBm)	Limit (dBm)	Margin (dB)	Antenna Height (m)	Table Angle (Degree)	Raw Value (dBuV)	Correction Factor (dB/m)
1	1658.00	-58.87	-13.00	-45.87	1.79 V	167	46.58	-105.45

**Remarks:**

1. ERP(dBm) = Raw Value(dBuV) + Correction Factor(dB/m)
2. Correction Factor(dB/m) = Antenna Factor(dB/m) + Cable Factor(dB) – Pre-Amplifier Factor(dB) + 20log(D) – 104.8 – 2.15
3. Margin value = ERP – Limit value
4. The other ERP levels were very low against the limit.

LTE Band 5

<b>RF Mode</b>	TX LTE Band XXVI-15MHz	<b>Channel</b>	CH 26915 : 836.5 MHz
<b>Frequency Range</b>	1GHz ~ 18GHz		

Antenna Polarity & Test Distance : Horizontal at 3 m								
No	Frequency (MHz)	ERP (dBm)	Limit (dBm)	Margin (dB)	Antenna Height (m)	Table Angle (Degree)	Raw Value (dBuV)	Correction Factor (dB/m)
1	1673.00	-58.11	-13.00	-45.11	1.99 H	47	47.35	-105.46
Antenna Polarity & Test Distance : Vertical at 3 m								
No	Frequency (MHz)	ERP (dBm)	Limit (dBm)	Margin (dB)	Antenna Height (m)	Table Angle (Degree)	Raw Value (dBuV)	Correction Factor (dB/m)
1	1673.00	-58.35	-13.00	-45.35	1.89 V	20	47.11	-105.46

Remarks:

1. ERP(dBm) = Raw Value(dBuV) + Correction Factor(dB/m)
2. Correction Factor(dB/m) = Antenna Factor(dB/m) + Cable Factor(dB) – Pre-Amplifier Factor(dB) + 20log(D) – 104.8 – 2.15
3. Margin value = ERP – Limit value
4. The other ERP levels were very low against the limit.

n5

<b>RF Mode</b>	TX 5GNR Band V-20MHz	<b>Channel</b>	CH 167300 : 836.5 MHz
<b>Frequency Range</b>	1GHz ~ 18GHz		

Antenna Polarity & Test Distance : Horizontal at 3 m								
No	Frequency (MHz)	ERP (dBm)	Limit (dBm)	Margin (dB)	Antenna Height (m)	Table Angle (Degree)	Raw Value (dBuV)	Correction Factor (dB/m)
1	1673.00	-57.02	-13.00	-44.02	2.71 H	4	47.30	-104.32
Antenna Polarity & Test Distance : Vertical at 3 m								
No	Frequency (MHz)	ERP (dBm)	Limit (dBm)	Margin (dB)	Antenna Height (m)	Table Angle (Degree)	Raw Value (dBuV)	Correction Factor (dB/m)
1	1673.00	-57.62	-13.00	-44.62	3.08 V	30	46.70	-104.32

Remarks:

1. ERP(dBm) = Raw Value(dBuV) + Correction Factor(dB/m)
2. Correction Factor(dB/m) = Antenna Factor(dB/m) + Cable Factor(dB) – Pre-Amplifier Factor(dB) + 20log(D) – 104.8 – 2.15
3. Margin value = ERP – Limit value
4. The other ERP levels were very low against the limit.

## 5 Pictures of Test Arrangements

Please refer to the attached file (Test Setup Photo).

## Appendix – Information of the Testing Laboratories

We, Bureau Veritas Consumer Products Services (H.K.) Ltd., Taoyuan Branch, were founded in 1988 to provide our best service in EMC, Radio, Telecom and Safety consultation. Our laboratories are FCC recognized accredited test firms and accredited according to ISO/IEC 17025.

If you have any comments, please feel free to contact us at the following:

**Lin Kou EMC/RF Lab**

Tel: 886-2-26052180

Fax: 886-2-26051924

**Hsin Chu EMC/RF/Telecom Lab**

Tel: 886-3-6668565

Fax: 886-3-6668323

**Hwa Ya EMC/RF/Safety Lab**

Tel: 886-3-3183232

Fax: 886-3-3270892

**Email:** [service.adt@tw.bureauveritas.com](mailto:service.adt@tw.bureauveritas.com)

**Web Site:** [www.bureauveritas-adt.com](http://www.bureauveritas-adt.com)

The address and road map of all our labs can be found in our web site also.

--- END ---