

Model DPC2434™ VoIP Wireless Home Gateway User's Guide

In This Document



■ IMPORTANT SAFETY INFORMATION	3
■ FCC Compliance.....	9
■ Introduction	10
■ What's In the Carton?	12
■ Front Panel Description.....	13
■ Back Panel Description	15
■ Where Is the Best Location for My Wireless Home Gateway?	17
■ What Are the System Requirements for Internet Service?	18
■ How Do I Set Up My High-Speed Internet Access Account?	19
■ How Do I Connect My Devices to Use the Internet?.....	20
■ How Do I Configure TCP/IP Protocol?	22
■ How Do I Install USB Drivers?	25
■ What Are the Requirements for Ethernet Network Devices?	27
■ How Do I Select and Place Ethernet Network Devices?	28
■ How Do I Connect Ethernet Network Devices?	29
■ What Are the Requirements for USB Network Devices?	31
■ How Do I Select and Place USB Network Devices?	32
■ How Do I Connect USB Network Devices?.....	33
■ How Do I Troubleshoot My Internet Service Installation?.....	35
■ What Are the Requirements for Wireless Network Devices?	38
■ How Do I Select and Place Wireless Network Devices?.....	39
■ How Do I Install Wireless Network Devices?	40
■ How Do I Use My Wireless Home Gateway for Telephone Service?.....	42
■ Where Do I Place My Wireless Home Gateway for Telephone Service?	43
■ What Are the Requirements for Telephone Service?	44

■ How Do I Install the Modem for Telephone Service?	45
■ How Do I Maintain the Batteries?	48
■ How Do I Mount the Modem on a Wall? (Optional)	50
■ How Do I Configure the Wireless Home Gateway?	54
■ Telephone Service Frequently Asked Questions	124
■ Having Difficulty?	126
■ Tips for Improved Performance	129
■ Front Panel LED Status Indicator Functions	130
■ Notices	133
■ For Information.....	135

IMPORTANT SAFETY INFORMATION

Notice to Installers

The servicing instructions in this notice are for use by qualified service personnel only. To reduce the risk of electric shock, do not perform any servicing other than that contained in the operating instructions, unless you are qualified to do so.

<p>Note to System Installer</p> <p>For this apparatus, the coaxial cable shield/ screen shall be grounded as close as practical to the point of entry of the cable into the building. For products sold in the US and Canada, this reminder is provided to call the system installer's attention to Article 820-93 and Article 820-100 of the NEC (or Canadian Electrical Code Part 1), which provides guidelines for proper grounding of the coaxial cable shield.</p>  <p>This symbol is intended to alert you that uninsulated voltage within this product may have sufficient magnitude to cause electric shock. Therefore, it is dangerous to make any kind of contact with any inside part of this product.</p>	<table border="1"> <tr> <td data-bbox="742 638 821 716"></td> <td data-bbox="821 604 1077 750"> <p>CAUTION RISK OF ELECTRIC SHOCK DO NOT OPEN</p> <p>AVIS RISQUE DE CHOC ÉLECTRIQUE NE PAS OUVRIR</p> </td> <td data-bbox="997 638 1077 716"></td> </tr> </table> <p>CAUTION: To reduce the risk of electric shock, do not remove cover (or back). No user-serviceable parts inside. Refer servicing to qualified service personnel.</p> <p>WARNING TO PREVENT FIRE OR ELECTRIC SHOCK, DO NOT EXPOSE THIS UNIT TO RAIN OR MOISTURE.</p>  <p>This symbol is intended to alert you of the presence of important operating and maintenance (servicing) instructions in the literature accompanying this product.</p>		<p>CAUTION RISK OF ELECTRIC SHOCK DO NOT OPEN</p> <p>AVIS RISQUE DE CHOC ÉLECTRIQUE NE PAS OUVRIR</p>	
	<p>CAUTION RISK OF ELECTRIC SHOCK DO NOT OPEN</p> <p>AVIS RISQUE DE CHOC ÉLECTRIQUE NE PAS OUVRIR</p>			

20060608SICM-EN

Notice à l'attention des installateurs de réseaux câblés

Les instructions relatives aux interventions d'entretien, fournies dans la présente notice, s'adressent exclusivement au personnel technique qualifié. Pour réduire les risques de chocs électriques, n'effectuer aucune intervention autre que celles décrites dans le mode d'emploi et les instructions relatives au fonctionnement, à moins que vous ne soyez qualifié pour ce faire.



<p>Remarque à l'attention de l'installateur du système</p> <p>Avec cet appareil, le blindage/écran du câble coaxial doit être mis à la terre aussi près que possible du point d'entrée du câble dans le bâtiment. En ce qui concerne les produits vendus aux États-Unis et au Canada, ce rappel est fourni pour attirer l'attention de l'installateur sur les articles 820-93 et 820-100 du Code national de l'électricité (ou Code de l'électricité canadien, Partie 1) qui fournissent des lignes directrices concernant la mise à la terre correcte du blindage (écran) du câble coaxial.</p>  <p>Ce symbole a pour but de vous prévenir que des tensions électriques non isolées existent à l'intérieur de ce produit, pouvant être d'une intensité suffisante pour causer des chocs électriques. Il est donc dangereux d'établir un contact quelconque avec l'une des pièces comprises à l'intérieur de ce produit.</p>	<table border="1"> <tr> <td data-bbox="742 1422 821 1500"></td> <td data-bbox="821 1393 1077 1534"> <p>CAUTION RISK OF ELECTRIC SHOCK DO NOT OPEN</p> <p>ATTENTION DANGER ÉLECTRIQUE NE PAS OUVRIR</p> </td> <td data-bbox="997 1422 1077 1500"></td> </tr> </table> <p>ATTENTION: Pour réduire les risques de chocs électriques, ne pas enlever le couvercle (ou le panneau arrière). Ne contient aucune pièce réparable par l'utilisateur. Confier les interventions aux techniciens d'entretien qualifiés.</p> <p>AVERTISSEMENT POUR ÉVITER LES INCENDIES OU LES CHOCs ÉLECTRIQUES, NE PAS EXPOSER L'APPAREIL À LA PLUIE OU À L'HUMIDITÉ.</p>  <p>Ce symbole a pour but de vous prévenir de la présence d'instructions importantes relatives au fonctionnement ou à l'entretien (et aux réparations) dans la documentation accompagnant ce produit.</p>		<p>CAUTION RISK OF ELECTRIC SHOCK DO NOT OPEN</p> <p>ATTENTION DANGER ÉLECTRIQUE NE PAS OUVRIR</p>	
	<p>CAUTION RISK OF ELECTRIC SHOCK DO NOT OPEN</p> <p>ATTENTION DANGER ÉLECTRIQUE NE PAS OUVRIR</p>			

20060610SICM-FR

IMPORTANT SAFETY INFORMATION

Mitteilung für CATV-Techniker

Die in dieser Mitteilung aufgeführten Wartungsanweisungen sind ausschließlich für qualifiziertes Fachpersonal bestimmt. Um die Gefahr eines elektrischen Schlags zu reduzieren, sollten Sie keine Wartungsarbeiten durchführen, die nicht ausdrücklich in der Bedienungsanleitung aufgeführt sind, außer Sie sind zur Durchführung solcher Arbeiten qualifiziert.

<p>Mitteilung an den Systemtechniker</p> <p>Für dieses Gerät muss der Koaxialkabelschutz/ Schirm so nahe wie möglich am Eintrittspunkt des Kabels in das Gebäude geerdet werden. Dieser Erinnerungshinweis liegt den in den USA oder Kanada verkauften Produkten bei. Er soll den Systemtechniker auf Paragraph 820-93 und Paragraph 820-100 der US-Elektrovorschrift NEC (oder der kanadischen Elektrovorschrift Canadian Electrical Code Teil 1) aufmerksam machen, in denen die Richtlinien für die ordnungsgemäße Erdung des Koaxialkabelschirms festgehalten sind.</p>	 <p>CAUTION RISK OF ELECTRIC SHOCK DO NOT OPEN</p> <p>ACHTUNG STROMSCHLAGEGFAHR, NICHT ÖFFNEN</p>
 <p>Dieses Symbol weist den Benutzer auf das Vorhandensein von nicht isolierten gefährlichen Spannungen im Gerät hin, die Stromschläge verursachen können. Ein Kontakt mit den internen Teilen dieses Produktes ist mit Gefahren verbunden.</p>	<p>ACHTUNG: Zur Vermeidung eines Stromschlags darf die Abdeckung (bzw. die Geräterückwand) nicht entfernt werden. Das Gerät enthält keine vom Benutzer wartbaren Teile. Wartungsarbeiten dürfen nur von qualifiziertem Fachpersonal durchgeführt werden.</p> <p>WARNUNG DAS GERÄT NICHT REGEN ODER FEUCHTIGKEIT AUSSETZEN, UM STROMSCHLAG ODER DURCH EINEN KURZSCHLUSS VERURSACHTEN BRAND ZU VERMEIDEN.</p>  <p>Dieses Symbol weist den Benutzer darauf hin, dass die mit diesem Produkt gelieferte Dokumentation wichtige Betriebs- und Wartungsanweisungen für das Gerät enthält.</p>

20060810SICM-GR

Aviso a los instaladores de sistemas CATV

Las instrucciones de reparación contenidas en el presente aviso son para uso exclusivo por parte de personal de mantenimiento cualificado. Con el fin de reducir el riesgo de descarga eléctrica, no realice ninguna otra operación de reparación distinta a las contenidas en las instrucciones de funcionamiento, a menos que posea la cualificación necesaria para hacerlo.

<p>Nota para el instalador del sistema</p> <p>En lo que se refiere a este aparato, el blindaje del cable coaxial debe conectarse a tierra lo más cerca posible al punto por el cual el cable entra en el edificio. En el caso de los productos vendidos en los EE. UU. y Canadá, el presente aviso se suministra para llamar la atención del instalador del sistema sobre los Artículos 820-93 y 820-100 del NEC (o Código Eléctrico de Canadá, Parte 1), que proporcionan directrices para una correcta conexión a tierra del blindaje del cable coaxial.</p>	 <p>CAUTION RISK OF ELECTRIC SHOCK DO NOT OPEN</p> <p>ATENCIÓN RIESGO DE DESCARGA ELÉCTRICA NO ABRIR</p>
 <p>Este símbolo tiene como fin advertirle de que una tensión sin aislamiento en el interior de este producto podría ser de una magnitud suficiente como para provocar una descarga eléctrica. Por consiguiente, resulta peligroso realizar cualquier tipo de contacto con alguno de los componentes internos de este producto.</p>	<p>ATENCIÓN: con el fin de reducir el riesgo de descarga eléctrica, no retire la tapa (ni la parte posterior). No existen en el interior componentes que puedan ser reparados por el usuario. Encargue su revisión a personal de mantenimiento cualificado.</p> <p>ADVERTENCIA PARA EVITAR EL RIESGO DE INCENDIO O DESCARGA ELÉCTRICA, NO EXPONGA LA UNIDAD A LA LLUVIA O A LA HUMEDAD.</p>  <p>Este símbolo tiene como fin alertarle de la presencia de importantes instrucciones de operación y mantenimiento (revisión) contenidas en la literatura que acompaña al producto.</p>

20060810SICM-SP

Heed All Warnings

Adhere to all warnings on the product and in the operating instructions.

Read, Retain, and Follow These Instructions

Carefully read all safety and operating instructions before operating this product. Follow all operating instructions that accompany this product. Retain the instructions for future use. Give particular attention to all safety precautions.

Comply with Warnings

Avoid electric shock. Comply with all warnings and cautions in the operating instructions, as well as those that are affixed to this product.

Power Warnings

Providing a Power Source

A label on this product indicates the correct power source for this product. Operate this product only from an electrical outlet with the voltage and frequency indicated on the product label.

If you are uncertain of the type of power supply to your home or business, consult your service provider or your local power company.

Grounding This Product (U.S.A. and Canada Only)



WARNING:

To avoid electric shock and fire hazard, do not defeat the safety purpose of the polarized or grounding-type plug. A polarized plug has two blades with one wider than the other. A grounding-type plug has two blades and a third grounding prong. The wide blade or the third prong is provided for your safety. If the provided plug does not fit into your outlet, consult an electrician for replacement of the obsolete outlet.

If this product is equipped with either a three-prong (grounding pin) safety plug or a two-prong (polarized) safety plug, do not defeat the safety purpose of the polarized or grounding-type plug. Follow these safety guidelines to properly ground this product:

- For a 3-prong plug (consists of two blades and a third grounding prong), insert the plug into a grounded mains, 3-prong outlet.
Note: This plug fits only one way. The grounding prong is provided for your safety. If you are unable to insert this plug fully into the outlet, contact your electrician to replace your obsolete outlet.
- For a 2-prong plug (consists of one wide blade and one narrow blade), insert the plug into a polarized mains, 2-prong outlet in which one socket is wider than the other.

IMPORTANT SAFETY INFORMATION

Note: If you are unable to insert this plug fully into the outlet, try reversing the plug. The wide blade is provided for your safety. If the plug still fails to fit, contact an electrician to replace your obsolete outlet.

Overloading



WARNING:

Avoid electric shock and fire hazard! Do not overload mains AC outlets and extension cords. For products that require battery power or other power sources to operate them, refer to the operating instructions for those products.

Do not overload electrical outlets, extension cords, or integral convenience receptacles as this can result in a risk of fire or electric shock. For products that require battery power or other sources to operate, refer to the operating instructions for that product.

Preventing Power Cord Damage

Protect the power cord from being walked on or pinched, particularly at plugs, convenience receptacles, and the point where they exit from the apparatus. Arrange all power cords so that pets cannot walk on or disturb the cords. Do not place objects on or lean objects against the cords, which can damage the cords.

Handling Replaceable Battery Pack

This product contains replaceable battery pack. Heed the following warning and see the instructions later in this guide for handling, replacing, and disposing of the battery.



WARNING:

There is danger of explosion if the battery is mishandled or incorrectly replaced. Replace only with the same type of battery. Do not disassemble it or attempt to recharge it outside the system. Do not crush, puncture, dispose of in fire, short the external contacts, or expose to water or other liquids. Dispose of the battery in accordance with local regulations and instructions from your service provider.

Usage Warnings

Providing Ventilation

- Do not block any ventilation openings. Install in accordance with the manufacturer's instructions.
- Do not place this apparatus on a bed, sofa, rug, or similar surface.
- Do not install near any heat sources such as radiators, heat registers, stoves, or other apparatus (including amplifiers) that produce heat.
- Do not install this apparatus in an enclosure, such as a bookcase or rack, unless the installation provides proper ventilation.
- Do not place entertainment devices (such as VCRs or DVDs), lamps, books, vases with liquids, or other objects on top of this product.
- Do not use this apparatus near water.

Selecting a Proper Location



WARNING:

Avoid personal injury and damage to this product! An unstable surface may cause this product to fall.

Place this product on a stable surface. The surface must support the size and weight of this product. Any mounting accessory used must be recommended by the manufacturer. The product should be mounted to a wall or ceiling only as recommended by the manufacturer.

Important! The power cord is the mains power supply disconnect device.

Place this product in a location that is close enough to an electrical outlet and where the power cord is easily accessible to be disconnected from the wall outlet or from the rear panel of the product.

Cleaning This Product



WARNING:

Avoid electric shock! Unplug this product before cleaning. Clean only with a dry cloth.

Before cleaning this product, unplug it from the electrical outlet. Clean this product only with a dry cloth. Do not use a liquid cleaner or an aerosol cleaner. Do not use a magnetic/static cleaning device (dust remover) to clean this product.

Protecting This Product from Foreign Objects and Water or Moisture Damage



WARNING:

Avoid electric shock and fire hazard! Never push objects through the openings in this product. Foreign objects can cause electrical shorts that can result in electric shock or fire. Do not expose this product to rain or moisture. Do not place objects filled with liquid, such as vases, on this product.

Never push objects of any kind into this product through openings as they may touch dangerous voltage points or short out parts that could result in a fire or electric shock.

Do not expose this product to liquids or moisture. Do not place this product on a wet surface. Do not spill liquids on or near this product.

Do not use this product near water (such as a bathtub, washbowl, sink, or laundry tub), in a wet basement, or near a swimming pool.

Accessories Warnings



WARNING:

Avoid any potential for electric shock or fire. Only use attachments/accessories specified by the manufacturer.

Do not use accessories or attachments with this product unless recommended by your service provider or manufacturer.

IMPORTANT SAFETY INFORMATION

Service Warnings

Servicing This Product



WARNING:

Avoid electric shock! Opening or removing the cover may expose you to dangerous voltages. This product contains no user-serviceable parts. Refer all servicing to qualified service personnel.

Do not open the cover of this product. If you open the cover, your warranty will be void. Refer all servicing to qualified personnel only. Contact your service provider for instructions.

Obtaining Service for Product Damage

For damage that requires service, unplug this product from the AC outlet. Refer all servicing to your service provider or qualified service personnel. Servicing is required when:

- The apparatus has been damaged in any way
- A power-supply cord or plug is damaged
- Liquid has been spilled or objects have fallen into the apparatus
- The apparatus has been exposed to rain or moisture
- The apparatus does not operate normally
- The apparatus has been dropped

Checking Product Safety

Upon completion of any service or repairs to this product, the service technician must perform safety checks to determine that this product is in proper operating condition.

Lightning

For added protection, unplug this apparatus during lightning storms or when unused for long periods of time. In addition to disconnecting the AC power from the wall outlet, disconnect the signal inputs. This may prevent damage to the apparatus due to lightning and power-line surges. Plugging this apparatus into a surge protector may reduce the risk of damage.

20060712MDBR

FCC Compliance

United States FCC Compliance

This device has been tested and found to comply with the limits for a Class B digital device, pursuant to part 15 of the FCC Rules. These limits are designed to provide reasonable protection against such interference in a residential installation. This equipment generates, uses, and can radiate radio frequency energy. If not installed and used in accordance with the instructions, it may cause harmful interference to radio communications. However, there is no guarantee that interference will not occur in a particular installation. If this equipment does cause harmful interference to radio or television reception, which can be determined by turning the equipment OFF and ON, the user is encouraged to try to correct the interference by one or more of the following measures:

- Reorient or relocate the receiving antenna.
- Increase the separation between the equipment and receiver.
- Connect the equipment into an outlet on a circuit different from that to which the receiver is connected.
- Consult the cable company or an experienced radio/television technician for help.

Any changes or modifications not expressly approved by Scientific-Atlanta, Inc., could void the user's authority to operate the equipment.

The information shown in the FCC Declaration of Conformity paragraph below is a requirement of the FCC and is intended to supply you with information regarding the FCC approval of this device. *The phone numbers listed are for FCC-related questions only and not intended for questions regarding the connection or operation for this device. Please contact your cable service provider for any questions you may have regarding the operation or installation of this device.*

FCC Declaration of Conformity

This device complies with Part 15 of FCC Rules. Operation is subject to the following two conditions: 1) the device may not cause harmful interference, and 2) the device must accept any interference received, including interference that may cause undesired operation.

<p>VoIP Wireless Home Gateway DPC2434 Scientific-Atlanta, Inc. 5030 Sugarloaf Parkway Lawrenceville, Georgia 30044 USA Telephone: 770-236-1077</p>
--

Canada EMI Regulation

This Class B digital apparatus complies with Canadian ICES-003.

Cet appareil numérique de la class B est conforme à la norme NMB-003 du Canada.

20060628FDC

Introduction

Welcome to the exciting world of high-speed Internet and high quality digital telephone service. Your new Model DPC2434 Voice-over-Internet Protocol (VoIP) Wireless Home Gateway is a cable modem that meets industry standards for high-speed data connectivity along with reliable digital telephone service. The DPC2434 wireless home gateway delivers data, voice and wired (Ethernet) or wireless gateway capabilities to connect a variety of devices in the home or small office and support high-speed data access and VoIP services, all in one device. With a DPC2434 wireless home gateway, your Internet enjoyment, home and business communications, and personal productivity will surely soar.

This guide provides procedures and recommendations for placing, installing, configuring, operating, and troubleshooting your DPC2434 wireless home gateway for high-speed Internet and digital telephone service for your home or office. Refer to the appropriate section in this guide for the specific information you need for your situation. Contact your service provider for more information about subscribing to these services.

Benefits and Features

Your new DPC2434 wireless home gateway offers the following outstanding benefits and features:

- Features an embedded media terminal adapter (EMTA) supporting two-line voice services
- Provides a high-speed broadband Internet connection that energizes your online experience, such as providing hassle-free downloading and sharing files and photos with your family and friends
- Includes four 10/100BaseT Ethernet ports and a USB port to provide connectivity for high-speed data services or to other Internet devices
- Assures a broad range of interoperability with most service providers by complying with Data Over Cable System Interface Specifications (DOCSIS) 1.0, 1.1, and 2.0 standards along with PacketCable 1.0 specifications to deliver high-end performance and reliability
- Includes two RJ-11 telephony ports for connecting conventional telephones or fax machines
- Allows you to attach multiple devices in your home or office to the wireless home gateway for high-speed wired and wireless networking and sharing of files and folders without first copying them onto a CD or diskette
- Includes up to two internal Lithium-Ion cartridge-style batteries for convenient and long-lasting backup power

- Features Plug and Play operation for easy set up and installation
- Provides parental control and advanced firewall technology
- Utilizes an attractive compact design that allows for vertical, horizontal, or wall-mount placement
- Allows automatic software upgrades by your service provider

What's In the Carton?

What's In the Carton?

When you receive your wireless home gateway, you should check the equipment and accessories to verify that each item is in the carton and that each item is undamaged. The carton contains the following items:



One DPC2434 Wireless Home Gateway



One AC power cord



One Ethernet cable (CAT5/RJ-45)



One USB cable



One CD-ROM containing the user's guide and the USB drivers



Lithium Ion cartridge battery (Optional)

If any of these items are missing or damaged, please contact your service provider for assistance.

Notes:

- You will need an optional cable signal splitter and additional standard RF coaxial cables if you want to connect a VCR, a Digital Home Communications Terminal (DHCT) or a set-top converter, or a TV to the same cable connection as your wireless home gateway.
- Cables and other equipment needed for telephone service must be purchased separately. Contact your service provider to inquire about the equipment and cables you need for telephone service.

Front Panel Description

The front panel of your wireless home gateway provides LED status indicators that indicate how well and at what state your wireless home gateway is operating. See *Front Panel LED Status Indicator Functions* (on page 130), for more information on front panel LED status indicator functions.

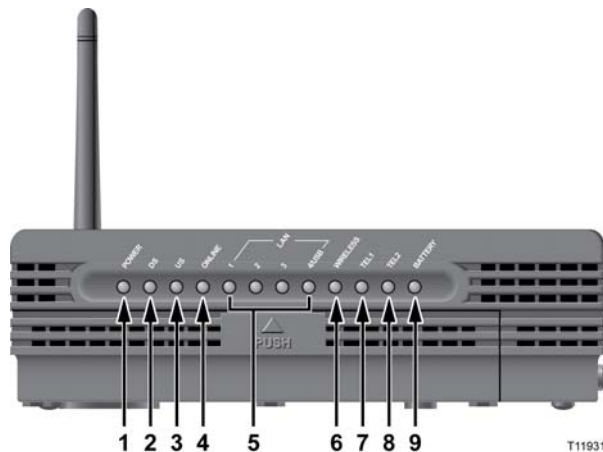

- 1 **POWER** – Illuminates solid green to indicate that AC power is being applied to the wireless home gateway. AC power must be available to recharge the batteries
- 2 **DS** – Blinks to indicate that the wireless home gateway is receiving data from the cable network
- 3 **US** – Blinks to indicate that the wireless home gateway is sending data to the cable network
- 4 **ONLINE** – Illuminates solid green when the wireless home gateway is registered on the network and fully operational
- 5 **LAN1 - LAN4/USB** – Illuminates solid green to indicate that an Ethernet/USB carrier is present and blinks to indicate that Ethernet/USB data is being transferred between the PC and the wireless home gateway
- 6 **WIRELESS** – Illuminates solid green when the wireless access point is enabled and operational and blinks to indicate that wireless data is being transferred between the PC and the wireless home gateway. The LED is off when the wireless access point is disabled by the user
- 7 **TEL1** – Illuminates solid green when telephony service is enabled. Blinks when line 1 is in use

Front Panel Description

- 8 **TEL2**— Illuminates solid green when telephony service is enabled. Blinks when line 2 is in use
- 9 **BATTERY**— Illuminates solid green to indicate that the battery is charged. Blinks to indicate that the battery charge is low. Off when operating from battery power or when the battery charge is depleted or the battery is defective

Notes:

- After the wireless home gateway is successfully registered on the network, the **POWER** (LED 1) and **ONLINE** (LED 4) LEDs illuminate continuously to indicate that the cable modem is active and fully operational.
- LEDs may behave differently when the wireless home gateway is running on battery power (without AC power). Most LEDs are disabled if the unit is operating on battery power. In this mode, the **POWER** LED blinks to indicate that the unit is operating under battery power but AC power has failed.

Note: The wireless home gateway is shut off when operating on battery power and only the telephone service is active.

Back Panel Description

The following illustration shows the description and function of the back panel components on the DPC2434.

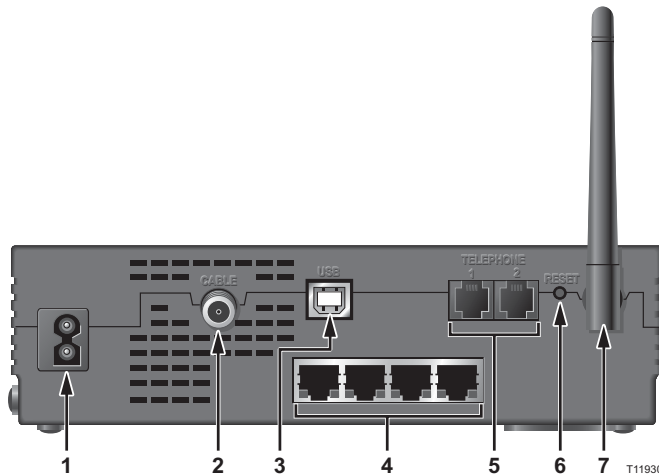

Important! Do not connect your PC to *both* the Ethernet and USB ports at the same time. Your modem will not function properly if both the Ethernet and USB ports are connected to your PC at the same time.

- 1 POWER** – Connects the wireless home gateway to the AC power plug that is provided with your wireless home gateway



CAUTION:

Avoid damage to your equipment. Only use the AC power cord that is provided with your cable modem.

- 2 CABLE** – F-Connector connects to an active cable signal from your cable service provider
- 3 USB** – 12 Mbps USB port connects to the USB port on your PC
- 4 ETHERNET** – Four RJ-45 Ethernet ports connect to the Ethernet port on your PC or your home network
- 5 TELEPHONE 1 and 2** – RJ-11 telephone ports connect to home telephone wiring to conventional telephones or fax machines

Back Panel Description

- 6 **RESET** – Activating this switch resets the EMTA. Pressing this switch for more than ten seconds resets the device to factory default values and resets the EMTA



CAUTION:

The Reboot EMTA button is for maintenance purposes only. Do not use unless instructed to do so by your cable or telephone service provider. Doing so may cause you to lose any cable modem settings you have selected.

- 7 **ANTENNA** – Provides a communication connection for the built-in wireless access point (WAP) to allow wireless devices to communicate with the cable modem

Where Is the Best Location for My Wireless Home Gateway?

The ideal location for your wireless home gateway is where it has access to outlets and other devices. Think about the layout of your home or office, and consult with your service provider to select the best location for your wireless home gateway. Read this user's guide thoroughly before you decide where to place your wireless home gateway.

Consider these recommendations:

- Position your PC and wireless home gateway so that they are located near an AC power outlet.
- Position your PC and wireless home gateway so that they are located near an existing cable input connection to eliminate the need for an additional cable outlet. There should be plenty of room to guide the cables away from the modem and the PC without straining or crimping them.
- Airflow around the wireless home gateway should not be restricted.
- Choose a location that protects the wireless home gateway from accidental disturbance or harm.

What Are the System Requirements for Internet Service?

To ensure that your wireless home gateway operates efficiently for high-speed Internet service, verify that all of the Internet devices on your system meet or exceed the following minimum hardware and software requirements.

Note: You will also need an active cable input line and an Internet connection.

Minimum System Requirements for a PC

- A PC with a Pentium MMX 133 processor or greater
- 32 MB of RAM
- Web browsing software
- CD-ROM drive

Minimum System Requirements for Macintosh

- MAC OS 7.5
- 32 MB of RAM

System Requirements for an Ethernet Connection

- A PC with Microsoft Windows 95 operating system (or later) with TCP/IP protocol installed, or an Apple Macintosh computer with TCP/IP protocol installed
- An active 10/100BaseT Ethernet network interface card (NIC) installed

System Requirements for a USB Connection

- A PC with Microsoft Windows 98SE, ME, 2000, or XP operating system
- A master USB port installed in your PC or your Apple Macintosh computer

How Do I Set Up My High-Speed Internet Access Account?

Before you can use your wireless home gateway, you need to have a high-speed Internet access account. If you do not have a high-speed Internet access account, you need to set up an account with your local service provider. Choose one of the two options in this section.

I Do Not Have a High-Speed Internet Access Account

If you do *not* have a high-speed Internet access account, your service provider will set up your account and become your Internet Service Provider (ISP). Internet access enables you to send and receive e-mail, access the World Wide Web, and receive other Internet services.

You will need to give your service provider the following information:

- The serial number of the modem
- The Media Access Control (MAC) address of the modem

These numbers appear on a bar code label located on the wireless home gateway. The serial number consists of a series of alphanumeric characters preceded by **S/N**. The MAC address consists of a series of alphanumeric characters preceded by **CM MAC**. The following illustration shows a sample bar code label.

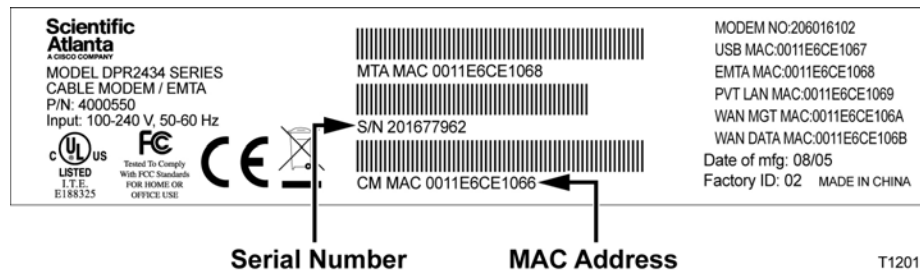

Serial Number

MAC Address

T12013

Write down these numbers in the space provided here.

Serial Number _____

MAC Address _____

I Already Have an Existing High-Speed Internet Access Account

If you have an existing high-speed Internet access account, you must give your service provider the serial number and the MAC address of the wireless home gateway. Refer to the serial number and MAC address information listed previously in this section.

Note: You may not be able to continue to use your existing e-mail account with your wireless home gateway. Contact your service provider for more information.

How Do I Connect My Devices to Use the Internet?

You can use your wireless home gateway to access the Internet, and you can share that Internet connection with other Internet devices in your home or office. Sharing one connection among many devices is called networking.

Connecting and Installing Internet Devices

You must connect and install your wireless home gateway to access the Internet. Professional installation may be available. Contact your local cable service provider for further assistance.

To connect devices

The following diagram illustrates one of the various networking options that are available to you.

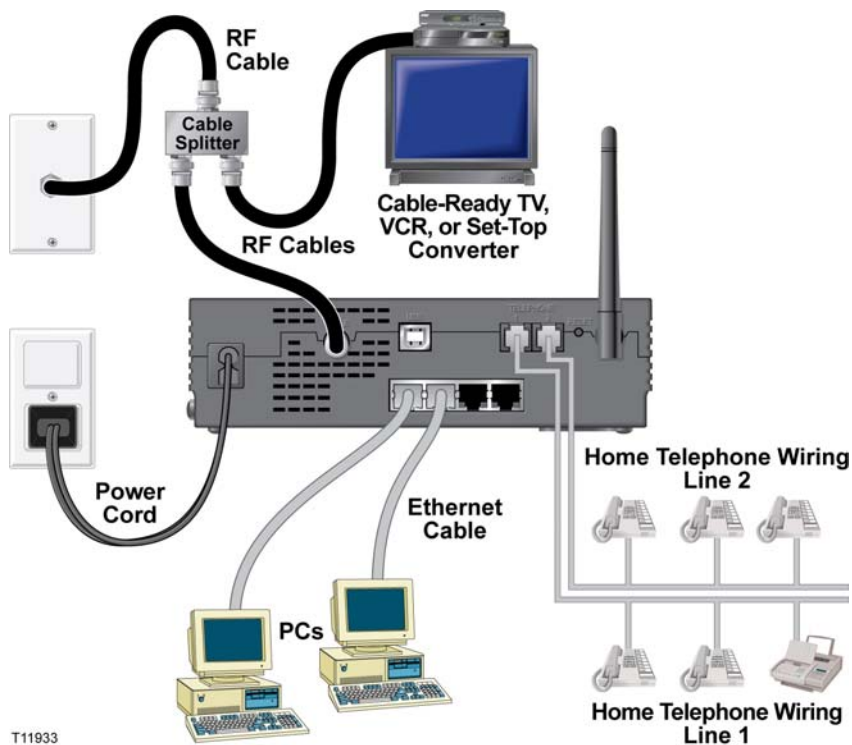

Connecting the Modem for High-Speed Data Service



WARNING:

To avoid personal injury or damage to your equipment, follow these steps in the exact order shown.

- 1 Power off your PC and unplug it from the power source.
- 2 Connect your PC to either the **ETHERNET** port or the **USB** port using the appropriate data cable. Do not connect your PC to both the Ethernet and USB ports at the same time. You can connect two separate PCs to the wireless home gateway at the same time by connecting one PC to the Ethernet port and one PC to the USB port.
- 3 Connect the active RF coaxial cable to the **CABLE** connector. Use an optional cable signal splitter to add a TV, a DHCT or set-top converter, or a VCR.
- 4 Insert the AC power cord into the **POWER** connector on the back of the wireless home gateway, and then plug the cord into an AC power source.
- 5 Plug in and power on your networked devices including your PC. The wireless home gateway will then begin an automatic search to locate and sign on to the broadband data network. This process may take up to 5 minutes. The modem will be ready for use when the **ONLINE** LED status indicator on the front panel stops blinking and illuminates continuously.
- 6 The next step in setting up your wireless home gateway is to configure your Internet devices for Internet access. Choose one of the following options:
 - If you want to use Ethernet connections, you must configure the TCP/IP protocol. To configure the TCP/IP protocol, go to *How Do I Configure TCP/IP Protocol?* (on page 22).
 - If you want to use USB connections, you must install the USB drivers. To install the USB Drivers for USB, go to *How Do I Install USB Drivers?* (on page 25).

How Do I Configure TCP/IP Protocol?

To configure TCP/IP protocol, you need to have an Ethernet Network Interface Card (NIC) with TCP/IP communications protocol installed on your system. TCP/IP is a communications protocol used to access the Internet. This section contains instructions for configuring TCP/IP on your Internet devices to operate with the wireless home gateway in Microsoft Windows or Macintosh environments.

Configuring TCP/IP on Your Internet Devices

TCP/IP protocol in a Microsoft Windows environment is different for each operating system. Follow the appropriate instructions in this section for your operating system.

Configuring TCP/IP on Windows 95, 98, 98SE, or ME Systems

- 1 Click **Start**, select **Settings**, and choose **Control Panel**.
- 2 Double-click the **Network** icon in the Control Panel window.
- 3 Read the list of installed network components under the **Configuration** tab to verify that your PC contains the TCP/IP protocol/Ethernet adapter.
- 4 Is TCP/IP protocol listed in the installed network components list?
 - If **yes**, go to step 7.
 - If **no**, click **Add**, click **Protocol**, click **Add**, and then go to step 5.
- 5 Click **Microsoft** in the Manufacturers list.
- 6 Click **TCP/IP** in the Network Protocols list, and then click **OK**.
- 7 Click the **TCP/IP Ethernet Adapter** protocol, and then choose **Properties**.
- 8 Click the **IP Address** tab, and then select **Obtain an IP address automatically**.
- 9 Click the **Gateway** tab and verify that these fields are empty. If they are not empty, highlight and delete all information from the fields.
- 10 Click the **DNS Configuration** tab, and then select **Disable DNS**.
- 11 Click **OK**.
- 12 Click **OK** when the system finishes copying the files, and then close all networking windows.
- 13 Click **YES** to restart your computer when the System Settings Change dialog box opens. The computer restarts. The TCP/IP protocol is now configured on your PC, and your Ethernet devices are ready for use.
- 14 Try to access the Internet. If you cannot access the Internet, go to *Having Difficulty?* (on page 126). If you still cannot access the Internet, contact your service provider for further assistance.

Configuring TCP/IP on Windows 2000 Systems

- 1 Click **Start**, select **Settings**, and choose **Network and Dial-up Connections**.
- 2 Double-click the **Local Area Connection** icon in the Network and Dial-up Connections window.
- 3 Click **Properties** in the Local Area Connection Status window.
- 4 Click **Internet Protocol (TCP/IP)** in the Local Area Connection Properties window, and then click **Properties**.
- 5 Select both **Obtain an IP address automatically** and **Obtain DNS server address automatically** in the Internet Protocol (TCP/IP) Properties window, and then click **OK**.
- 6 Click **Yes** to restart your computer when the Local Network window opens. The computer restarts. The TCP/IP protocol is now configured on your PC, and your Ethernet devices are ready for use.
- 7 Try to access the Internet. If you cannot access the Internet, go to *Having Difficulty?* (on page 126). If you still cannot access the Internet, contact your service provider for further assistance.

Configuring TCP/IP on Windows XP Systems

- 1 Click **Start**, and depending on your Start menu setup, choose one of the following options:
 - If you are using the Windows XP Default Start Menu, select **Connect to**, choose **Show all connections**, and then go to step 2.
 - If you are using the Windows XP Classic Start Menu, select **Settings**, choose **Network Connections**, click **Local Area Connection**, and then go to step 3.
- 2 Double-click the **Local Area Connection** icon in the LAN or High-Speed Internet section of the Network Connections window.
- 3 Click **Properties** in the Local Area Connection Status window.
- 4 Click **Internet Protocol (TCP/IP)**, and then click **Properties** in the Local Area Connection Properties window.
- 5 Select both **Obtain an IP address automatically** and **Obtain DNS server address automatically** in the Internet Protocol (TCP/IP) Properties window, and then click **OK**.
- 6 Click **Yes** to restart your computer when the Local Network window opens. The computer restarts. The TCP/IP protocol is now configured on your PC, and your Ethernet devices are ready for use.
- 7 Try to access the Internet. If you cannot access the Internet, go to *Having Difficulty?* (on page 126). If you still cannot access the Internet, contact your service provider for further assistance.

How Do I Configure TCP/IP Protocol?

Configuring TCP/IP on Macintosh Systems

- 1 Click the **Apple** icon in the upper-left corner of the Finder. Scroll down to **Control Panels**, and then click **TCP/IP**.
- 2 Click **Edit** on the Finder at the top of the screen. Scroll down to the bottom of the menu, and then click **User Mode**.
- 3 Click **Advanced** in the User Mode window, and then click **OK**.
- 4 Click the Up/Down selector arrows located to the right of the Connect Via section of the TCP/IP window, and then click **Using DHCP Server**.
- 5 Click **Options** in the TCP/IP window, and then click **Active** in the TCP/IP Options window.

Note: Make sure that the **Load only when needed option** is *unchecked*.

- 6 Verify that the **Use 802.3** option located in the upper-right corner of the TCP/IP window is unchecked. If there is a check mark in the option, uncheck the option, and then click **Info** in the lower-left corner.
- 7 Is there a Hardware Address listed in this window?
 - If **yes**, click **OK**. To close the TCP/IP Control Panel window, click **File**, and then scroll down to click **Close**. You have completed this procedure.
 - If **no**, you must power off your Macintosh.
- 8 With the power off, simultaneously press and hold down the **Command (Apple)**, **Option, P**, and **R** keys on your keyboard. Keeping those keys pressed down, power on your Macintosh but do not release these keys until you hear the Apple chime at least three times, then release the keys and let the computer restart.
- 9 When your computer fully reboots, repeat steps 1 through 7 to verify that all TCP/IP settings are correct. If your computer still does not have a Hardware Address, contact your authorized Apple dealer or Apple technical support center for further assistance.

How Do I Install USB Drivers?

To install USB drivers, your PC must be equipped with a USB network interface and a Microsoft Windows 98SE, ME, 2000, or XP operating system. This section contains instructions for installing the USB drivers for the wireless home gateway.

Note: If you are not using the USB interface, skip this section.

Installing USB Drivers

The USB driver installation procedures are different for each operating system. Follow the appropriate instructions in this section for your operating system.

Installing USB Drivers on Windows 98SE and Windows ME Systems

- 1 Insert the **USB Cable Modem Driver Installation Disk** into the CD-ROM drive of your PC.
- 2 Wait until the **POWER** and **ONLINE** LED status indicators on the front panel of the wireless home gateway illuminate solid green. The Add New Hardware Wizard window opens.
- 3 Click **Next** in the Add New Hardware Wizard window.
- 4 Select **Search for the best driver for your device (Recommended)** in the Add New Hardware Wizard window, and then click **Next**.
- 5 Select **CD-ROM drive** in the Add New Hardware Wizard window, and then click **Next**.
- 6 Select **The updated driver (Recommended)** in the Add New Hardware Wizard window, and then click **Next**.
- 7 Click **Next** in the Add New Hardware Wizard window. The Copying Files window opens. After 10 to 20 seconds have passed, the Add New Hardware Wizard window reopens.
- 8 Click **Finish**. The USB driver installation is complete.

Installing USB Drivers on Windows 2000 Systems

- 1 Insert the **USB Cable Modem Driver Installation Disk** into the CD-ROM drive of your PC.
- 2 Wait until the **POWER** and **ONLINE** LED status indicators on the front panel of the wireless home gateway illuminate solid green.
- 3 Click **Next** in the Found New Hardware Wizard window.
- 4 Select **Search for a suitable driver for my device (recommended)** in the Found New Hardware Wizard window, and then click **Next**.
- 5 Select **CD-ROM drives** in the Found New Hardware Wizard window, and then click **Next**.

How Do I Install USB Drivers?

- 6 Click **Next** in the Found New Hardware Wizard window. The system searches for the driver file for your hardware device.
- 7 After the system finds the USB driver, the Digital Signature Not Found window opens and displays a confirmation message to continue the installation.
- 8 Click **Yes** to continue the installation. The Found New Hardware Wizard window reopens with a message that the installation is complete.
- 9 Click **Finish** to close the Found New Hardware Wizard window. The USB drivers are installed on your PC, and your USB devices are ready for use.
- 10 Try to access the Internet. If you cannot access the Internet, go to *Having Difficulty?* (on page 126). If you still cannot access the Internet, contact your service provider for further assistance.

Installing USB Drivers on Windows XP Systems

- 1 Insert the **USB Cable Modem Driver Installation Disk** into the CD-ROM drive of your PC.
- 2 Wait until the **POWER** and **ONLINE** LED status indicators on the front panel of the wireless home gateway illuminate solid green.
- 3 Select **Install from a list or specific location (Advanced)** in the Found New Hardware Wizard window, and then click **Next**.
- 4 Select **Search removable media (floppy, CD-ROM)** in the Found New Hardware Wizard window, and then click **Next**.
- 5 Click **Continue Anyway** in the Hardware Installation window to continue the installation. The Found New Hardware Wizard window reopens with a message that the installation has finished.
- 6 Click **Finish** to close the Found New Hardware Wizard window. The USB drivers are installed on your PC, and your USB devices are ready for use.
- 7 Try to access the Internet. If you cannot access the Internet, go to *Having Difficulty?* (on page 126). If you still cannot access the Internet, contact your service provider for further assistance.

What Are the Requirements for Ethernet Network Devices?

How Many Ethernet Network Devices Can I Connect?

The Scientific Atlanta wireless home gateway can support several Ethernet network devices using external Ethernet hubs that must be purchased separately.

The theoretical maximum number of Ethernet network devices supported by the wireless home gateway is 63. However, under normal circumstances, the number of devices connected should be a much lower number.

Contact your service provider for more information on the maximum number of Ethernet network devices to connect to your wireless home gateway to maintain optimal network performance.

What Are the Wiring Requirements for Ethernet Networking?

A number of factors can impact the practical limit of the network. Although the wireless home gateway is designed to support several Ethernet network devices, it is important to view the characteristics of the entire network and not just each individual node.

The theoretical distance between two 10/100BaseT CAT-5 Ethernet hubs is 382 feet (100 meters). Contact your service provider or consult the documentation for your Ethernet network devices for more information.

Note: Scientific Atlanta recommends that you use CAT-5 Ethernet cables.

Do I Need to Configure the TCP/IP Protocol on My Computer?

For you to use Ethernet network devices on your network, you must have the TCP/IP protocol properly configured on your PC. Refer to *How Do I Configure TCP/IP Protocol?* (on page 22), for detailed information on configuring the TCP/IP protocol.

How Do I Select and Place Ethernet Network Devices?

You can use a large variety of Ethernet network devices with your wireless home gateway. These include NIC cards, hubs, bridges, etc. Contact your service provider or consult the documentation for your Ethernet network devices for more information on configuring Ethernet network devices.

Where Is the Best Location for My Ethernet Network Devices?

You should work with your service provider to choose the best location for your Ethernet network devices. Consider these recommendations:

- Location of two-way cable outlets
- Distance of the Ethernet network devices from the wireless home gateway
- Location of computers and other equipment from AC power outlets
- Ease of running Ethernet cable to the Ethernet network devices

Now that you have selected a location for your Ethernet network devices, the next step is to place and connect your Ethernet network devices. Go to *How Do I Connect Ethernet Network Devices?* (on page 29).

How Do I Connect Ethernet Network Devices?

Connecting Ethernet Devices

You must connect your Ethernet devices for use with the wireless home gateway. Professional installation may be available. Contact your local service provider for further assistance.

The following diagram illustrates one of the various Ethernet network connection options that are available to you.

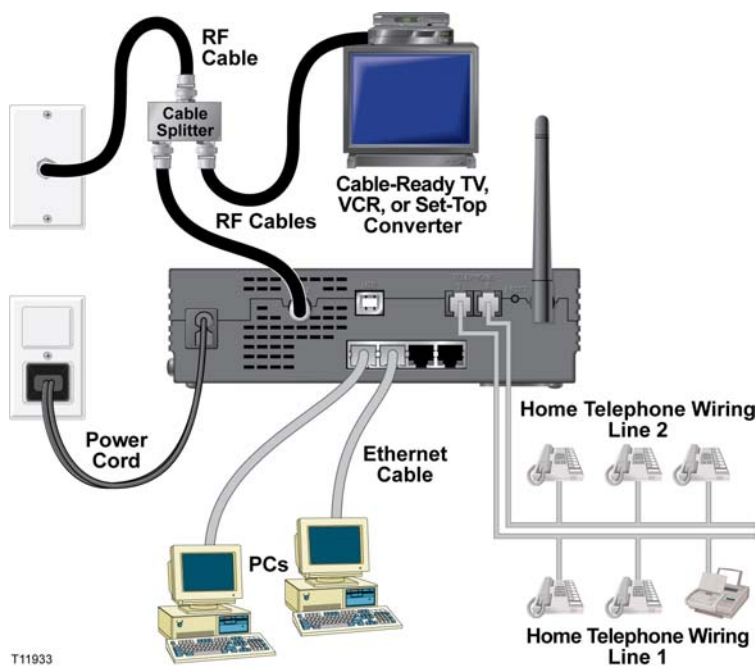

T11933



WARNING:

Hazardous electrical voltages can be present on any connected wiring. Ethernet wiring and connections must be properly insulated to prevent electrical shock. Disconnect power from the wireless home gateway before attempting to connect to any device.

To avoid personal injury, follow these steps in the exact order shown.



CAUTION:

To prevent possible damage to the equipment, disconnect any other service before connecting your wireless home gateway to other devices.

Read the warnings and caution on this page. Then, follow the subsequent installation procedures to ensure proper wireless home gateway operation when connecting Ethernet network devices.

How Do I Connect Ethernet Network Devices?

- 1 Select locations for Ethernet network devices. For more information, see *How Do I Select and Place Ethernet Network Devices?* (on page 28).
- 2 Connect the Ethernet port on the wireless home gateway to your PC.
- 3 Connect additional Ethernet network devices by connecting an Ethernet hub or router to the wireless home gateway.
- 4 Connect the active RF coaxial cable to the **CABLE** connector on the back of the wireless home gateway. Use an optional cable signal splitter to add a TV, a DHCT or set-top converter, or a VCR.
- 5 After all connections are complete, insert the AC power cord into the **POWER** connector on the back of the wireless home gateway, and then plug the cord into an AC power source.
- 6 The wireless home gateway begins an automatic search to locate and sign on to the network. In some unusual circumstances, this process may take up to 5 minutes. The wireless home gateway is ready for use when the **ONLINE** LED status indicator on the front panel stops blinking and illuminates continuously.
- 7 Verify that all Ethernet network devices are working properly.

Note: You will not be able to check the front panel LED status indicator on the wireless home gateway until after one or more Ethernet network devices are connected to the wireless home gateway.

What Are the Requirements for USB Network Devices?

How Many USB Devices Can I Connect?

Contact your service provider for more information on the maximum number of USB network devices to connect to the wireless home gateway to maintain optimal network performance.

What Are the Wiring Requirements?

Several factors can impact the practical limit of the network. Contact your service provider or consult the documentation for your USB network device for more information.

Do I Need to Install USB Drivers on My Computer?

To use USB network devices, you must have the correct USB drivers installed on your PC. Refer to *How Do I Install USB Drivers?* (on page 25), for information on installing USB drivers.

How Do I Select and Place USB Network Devices?

You can use a large variety of USB network devices with your wireless home gateway. These include desktop computers, laptop computers, devices with USB ports, and USB adapters.

Contact your service provider or consult the documentation for your USB network devices for more information on selecting USB network devices.

Where Is the Best Location for My USB Network Devices?

You should work with your service provider to choose the best location for your USB network devices. Consider these recommendations:

- Location of two-way coaxial cable outlets
- Distance of the USB network devices from the wireless home gateway
- Location of computers and other equipment from AC power outlets
- Ease of running USB cable to the USB network devices

Now that you have selected a location for your USB network devices, the next step is to place and connect your USB network devices. Go to *How Do I Connect USB Network Devices?* (on page 33).

How Do I Connect USB Network Devices?

Connecting USB Devices

You must connect your USB devices for use with your wireless home gateway. Professional installation may be available. Contact your local service provider for further assistance.

The following diagram illustrates one of the various USB network connection options that are available to you.

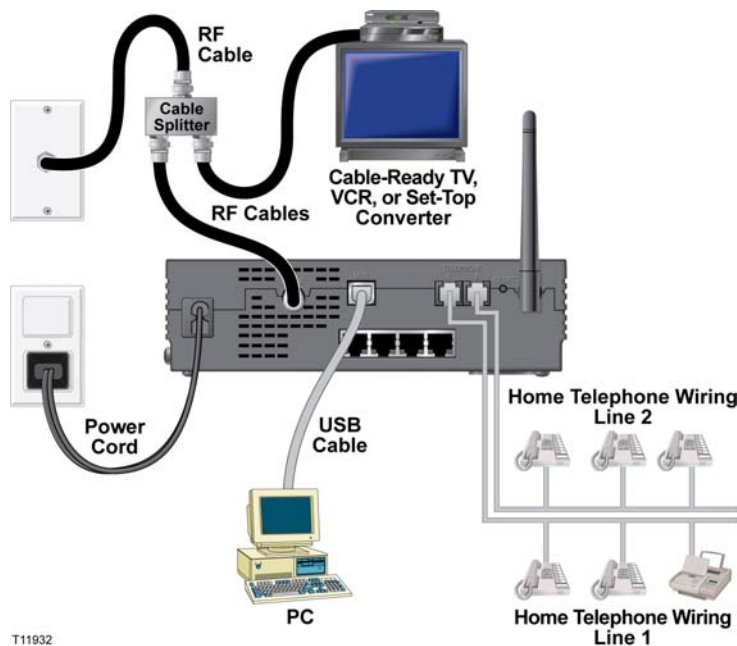

T11932



WARNING:

Hazardous electrical voltages can be present on any connected wiring. USB wiring and connections must be properly insulated to prevent electrical shock. Disconnect power from the wireless home gateway before attempting to connect to any device.

To avoid personal injury, follow these steps in the exact order shown.



CAUTION:

To prevent possible damage to the equipment, disconnect any other service before connecting your wireless home gateway to other devices.

Read the warnings and caution on this page. Then, follow the subsequent installation procedures to ensure proper wireless home gateway operation when connecting USB network devices.

How Do I Connect USB Network Devices?

Note: Verify that you have installed the USB drivers on your PC before continuing with these instructions. See *How Do I Install USB Drivers?* (on page 25), for more information on installing the USB drivers.

- 1 Select locations for USB network devices. For more information, see *How Do I Select and Place USB Network Devices?* (on page 31).
- 2 Connect the USB port on the wireless home gateway to your PC.
- 3 Connect one or more USB network device to the wireless home gateway.
- 4 Connect the active RF coaxial cable to the **CABLE** connector on the back of the wireless home gateway. Use an optional cable signal splitter to add a TV, a DHCT or set-top converter, or a VCR.
- 5 After all connections are complete, insert the AC power cord into the **POWER** connector on the back of the wireless home gateway, and then plug the cord into an AC power source.
- 6 The wireless home gateway begins an automatic search to locate and sign on to the network. In some unusual circumstances, this process may take up to 5 minutes. The wireless home gateway is ready for use when the **ONLINE** LED status indicator on the front panel stops blinking and illuminates continuously.
- 7 Verify that all USB network devices are working properly.

Note: You will not be able to check the front panel LED status indicator on the wireless home gateway until after one or more Ethernet network devices are connected to the wireless home gateway.

How Do I Troubleshoot My Internet Service Installation?

I cannot connect to the Internet

- Verify that the plug to your wireless home gateway AC power is properly inserted into an electrical outlet.
- Verify that your wireless home gateway AC power cord is not plugged into an electrical outlet that is controlled by a wall switch. If a wall switch controls the electrical outlet, make sure the switch is in the **ON** position.
- Verify that the **POWER** and **CABLE** indicator lights on the front panel of your wireless home gateway are illuminated.
- Verify that the indicator lights on your router or other network connection equipment are illuminated
- Verify that all cables are properly connected, and that you are using the correct cables.
- Verify that your cable service is active and that it supports two-way service.
- Verify that TCP/IP is properly installed and configured on all devices if you are using the Ethernet connections.
- Verify that you have followed the procedure in **How Do I Install USB Drivers?** (on page 25), if you are using the USB connection.
- Verify that you have called your service provider and given them the serial number and MAC address of your wireless home gateway.
- If you are using a cable signal splitter so that you can connect the cable signal to other devices, remove the splitter and reconnect the cable so that the wireless home gateway is connected directly to the main cable input. If the wireless home gateway now functions properly, the cable signal splitter may be defective and may need to be replaced.

My wireless home gateway does not register an Ethernet connection

Even new devices do not always have Ethernet capabilities. Verify that your device has an Ethernet card and that the Ethernet driver software is properly installed. If you purchase and install an Ethernet card, follow the installation instructions very carefully.

My wireless home gateway does not register a cable connection

- The wireless home gateway works with a standard, 75-ohm, RF coaxial cable. If you are using a different cable, your wireless home gateway will not function properly. Contact your service provider to determine if you are using the correct cable.
- You may need to renew the IP address on your PC. Refer to *How Do I Renew the IP Address on My PC?* (on page 37), for instructions on how to renew the IP address for your particular operating system.
- Your USB interface may be malfunctioning. Refer to the troubleshooting information in your USB documentation.

How Do I Renew the IP Address on My PC?

If your PC cannot access the Internet after the wireless home gateway is online, it is possible that your PC did not renew its IP address. Follow the appropriate instructions in this section for your operating system to renew the IP address on your PC.

Renewing the IP address on Windows 95, 98, 98SE, and ME Systems

- 1 Click **Start**, and then click **Run** to open the Run window.
- 2 Type **winipcfg** in the Open field, and click **OK** to execute the winipcfg command. The IP Configuration window opens.
- 3 Click the down arrow to the right of the top field, and select the Ethernet adapter that is installed on your PC. The IP Configuration window displays the Ethernet adapter information.
- 4 Click **Release**, and then click **Renew**. The IP Configuration window displays a new IP address.
- 5 Click **OK** to close the IP Configuration window, you have completed this procedure.

Note: If you cannot access the Internet, contact your service provider for further assistance.

Renewing the IP Address on Windows NT, 2000, or XP Systems

- 1 Click **Start**, and then click **Run**. The Run window opens.
- 2 Type **cmd** in the Open field and click **OK**. A window with a command prompt opens.
- 3 Type **ipconfig/release** at the C:/ prompt and press **Enter**. The system releases the IP address.
- 4 Type **ipconfig/renew** at the C:/ prompt and press **Enter**. The system displays a new IP address.
- 5 Click the **X** in the upper-right corner of the window to close the Command Prompt window. You have completed this procedure.

Note: If you cannot access the Internet, contact your service provider for further assistance.

What Are the Requirements for Wireless Network Devices?

How Many Wireless Devices Can I Connect?

The DPC2434 serves as a wireless access point (WAP). The WAP on the DPC2434 provides wireless network service to multiple wireless network devices. Contact your cable service provider for more information on the maximum number of wireless network devices to connect to the DPC2434 in order to maintain optimal network performance.

What are the Requirements for Wireless Networking?

It is important to view the characteristics of the entire network and not just each individual node. The theoretical distance between wireless network devices is 100 feet inside of a building, and 300 feet outdoors.

A number of factors can impact the practical limit of the network. Contact your cable service provider or consult the documentation for your wireless network devices for more information.

How Do I Select and Place Wireless Network Devices?

You can use a large variety of wireless network devices with your wireless home gateway. These include computers, PDAs, etc. On the wireless network, all devices impact the characteristics of the network, because each device transmits a wireless signal. Contact your cable service provider or consult the documentation for your wireless network device for more information on selecting the appropriate wireless network devices for your home or office network.

Where Is the Best Location for My Wireless Network Devices?

You should work with your cable service provider to choose the best location for your wireless network devices. Consider these recommendations:

- Distance from the wireless home gateway to the wireless network devices.
- Do not place the wireless home gateway near metallic surfaces that may block the wireless communications path. Wireless communication is “line-of-sight” through non-metallic walls. However, the more structures (walls) the signal must pass through, the weaker the received signal.
- Do not place wireless network devices near a microwave oven. When operating, microwave ovens can interfere with wireless transmissions.
- Do not place your wireless network devices near 2.4 GHz wireless telephones because these telephones may also cause interference with your wireless network.

Now that you have selected a location for your wireless network devices, the next step is to place and install your wireless network devices. Go to *How Do I Install Wireless Network Devices?* (on page 40).

How Do I Install Wireless Network Devices?

Installing Wireless Network Devices

You must install wireless network devices for use with your wireless home gateway. Professional installation may be available. Contact your local cable service provider for further assistance.

The following diagram illustrates one of the various wireless network connection options that are available to you.

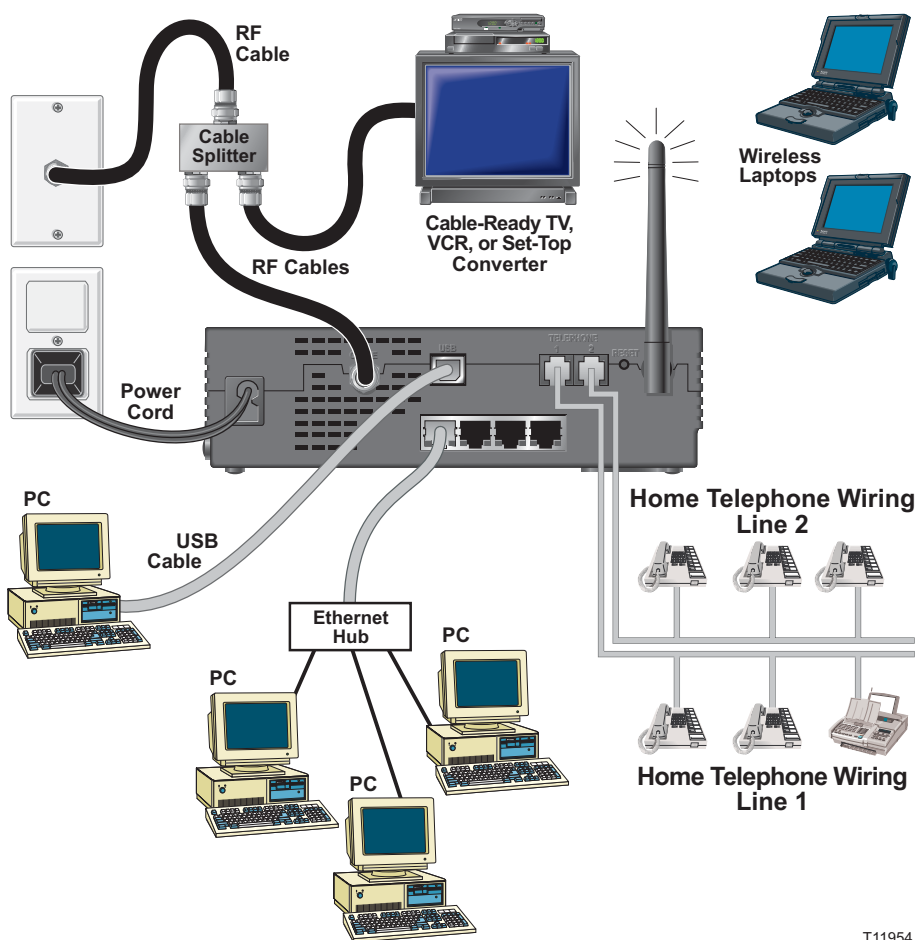

T11954

To install wireless network devices



WARNING:

Hazardous electrical voltages can be present on any connected wiring. Ethernet wiring and connections must be properly insulated to prevent electrical shock. Disconnect power from the wireless home gateway before attempting to connect to any device.

To avoid personal injury, follow these steps in the exact order shown.



CAUTION:

To prevent possible damage to the equipment, disconnect any other service before connecting your wireless home gateway to other devices.

Read the warnings and caution on this page. Then, follow the subsequent installation procedures to ensure proper wireless home gateway operation when using wireless network devices.

Installing Wireless Network Devices

Follow these steps to install the wireless home gateway for accessing wireless network devices.

- 1 Select locations for wireless network devices. For more information, see *How Do I Select and Place Wireless Network Devices?* (on page 39).
- 2 Connect and install the wireless network device(s).
- 3 Connect the active RF coaxial cable to the **CABLE** connector on the back of the wireless home gateway. Use an optional cable signal splitter to add a TV, a DHCT or set-top converter, or a VCR.
- 4 After all connections are complete, insert the AC power cord into the **POWER** connector on the back of the wireless home gateway, and then plug the power cord into an AC power source. The wireless home gateway begins an automatic search to locate and sign on to the network. In some unusual circumstances, this process may take up to 5 minutes. The wireless home gateway is ready for use when the **ONLINE** LED status indicator on the front panel stops blinking and illuminates continuously.

Note: Some 2.4 GHz cordless telephones can interfere with wireless signals. Unplug and disconnect any cordless phones until your wireless network is operating properly.

- 5 Verify that all wireless network devices are working properly.

How Do I Use My Wireless Home Gateway for Telephone Service?

Contacting Your Local Service Provider

You need to set up a telephone account with your local service provider to use your wireless home gateway for telephone service. When you contact your service provider, verify the following conditions:

- Does the service to your home support two-way, DOCSIS-compatible wireless home gateway access? If your service provider does not provide two-way service, this modem will not be able to communicate with your service provider's Internet access and telephone services.
- Can you transfer your existing telephone numbers from another telephony service provider to your current telephony service provider? In some areas, you may be able to transfer your existing telephone numbers, or your cable telephony service provider will assign a new telephone number for each current or additional active telephone line. Discuss these options with your telephony service provider.

You will need to give your service provider the following information:

- The serial number of the modem
- The Media Access Control (MAC) address of the modem

These numbers appear on a bar code label located on the wireless home gateway. The serial number consists of a series of alphanumeric characters preceded by **S/N**. The MAC address consists of a series of alphanumeric characters preceded by **CM MAC**. The following illustration shows a sample bar code label.

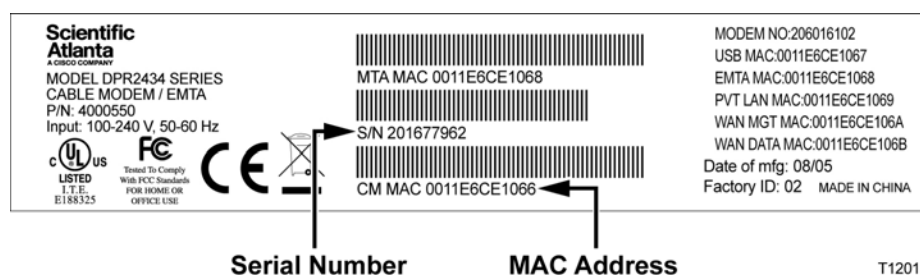

Write down these numbers in the space provided here.

Serial Number _____

MAC Address _____

Where Do I Place My Wireless Home Gateway for Telephone Service?

If you are planning to use your modem for telephone service, you should work with your cable telephony provider to choose the best location for your modem.

Where Is the Best Location for My Modem?

When choosing a location for your modem, consider the following recommendations:

- Choose a location close to your computer if you will also use the wireless home gateway for high-speed Internet service.
- Choose a location that is near an existing RF coaxial connection to eliminate the need for an additional RF coaxial outlet.
- Choose a location for the wireless home gateway that is adjacent to your telephone equipment if you are using only one or two pieces of telephone equipment.

Note: If you are using the wireless home gateway to provide service to several telephones, a professional installer can connect the wireless home gateway to your existing home telephone wiring. To minimize changes to the home telephone wiring, you may want to locate the wireless home gateway near an existing telephone outlet. See *How Do I Install the Modem for Telephone Service?* (on page 45), for further instructions.

- Choose a location that is relatively protected from accidental disturbance or harm, such as a closet, basement, or other protected area.
- Choose a location so that there is plenty of room to guide the cables away from the modem without straining or crimping them.
- Airflow around the wireless home gateway should not be restricted.
- Read this user's guide thoroughly before installing the wireless home gateway.

What Are the Requirements for Telephone Service?

This section provides hardware and software requirements for using your wireless home gateway for telephone service.

Number of Telephone Devices

The RJ-11 telephone-style connectors on the wireless home gateway can each provide telephone service to multiple telephones, fax machines, and analog modems.

The maximum number of telephone devices connected to each RJ-11 port is limited by the total Ringing Load of the telephone devices that are connected. Many telephone devices are marked with a Ringer Equivalent Number (REN). Each telephone port on the wireless home gateway can support up to a 5 REN load.

The sum of the REN load on all of the telephone devices attached to each port must not exceed 5 REN.

Telephone Device Types

You can use telephone devices that are not labeled with a REN number, but the maximum number of attached telephone devices cannot be accurately calculated. With telephone devices that are not labeled, each device should be connected and the ring signal should be tested before adding more devices. If too many telephone devices are attached and the ring signal can no longer be heard, telephone devices should be removed until the ring signal works properly.

Telephones, fax machines, and other telephone devices should use the center 2 pins of the RJ-11 connectors to connect to the wireless home gateway telephone ports. Some telephones use other pins on the RJ-11 connectors and require adapters in order to work.

Dialing Requirements

All your telephones should be set to use DTMF dialing. Pulse dialing is typically not enabled by your local provider.

Telephone Wiring Requirements

The wireless home gateway supports interior telephone wiring. The maximum distance from the unit to the most distant telephone device must not exceed 1000 feet (300 meters). Use 26-gauge twisted-pair, or larger, telephone wiring.

Important! Connection to an existing or a new permanently installed home telephone-wiring network must be done by a qualified installer.

How Do I Install the Modem for Telephone Service?

The wireless home gateway can be used to provide telephone service for one or two telephone lines. This section describes how to connect a single telephone, fax machine, analog telephone modem, or other telephone device to each telephone port on the wireless home gateway.

Important! Connecting the wireless home gateway permanently to the installed home telephone wiring is not covered by this document.

Installing the Modem to Provide Telephone Service

Heed the following warnings, and then follow the subsequent installation procedures to ensure proper wireless home gateway installation and configuration for providing telephone service.



WARNING:

- To avoid personal injury, follow the installation instructions in the exact order shown.
- Telephone connections to an installed home telephone wiring network must be done by a qualified installer. The cable telephone service provider may offer professional installation and connection to the home telephone wiring network. A fee may be charged for this service.
- Hazardous electrical voltages can exist on the telephone ports on the cable modem and can be present on any connected wiring. Telephone wiring and connections must be properly insulated to prevent electrical shock. Disconnect power from the cable modem before attempting to connect to any device.
- To prevent possible damage to equipment, disconnect any other telephone service before connecting your cable modem to the same wires.

Note: Professional installation may be available. Contact your service provider for further assistance.

How Do I Install the Modem for Telephone Service?

Installation Diagram

The following diagram illustrates one of the various connection options that are available to you.

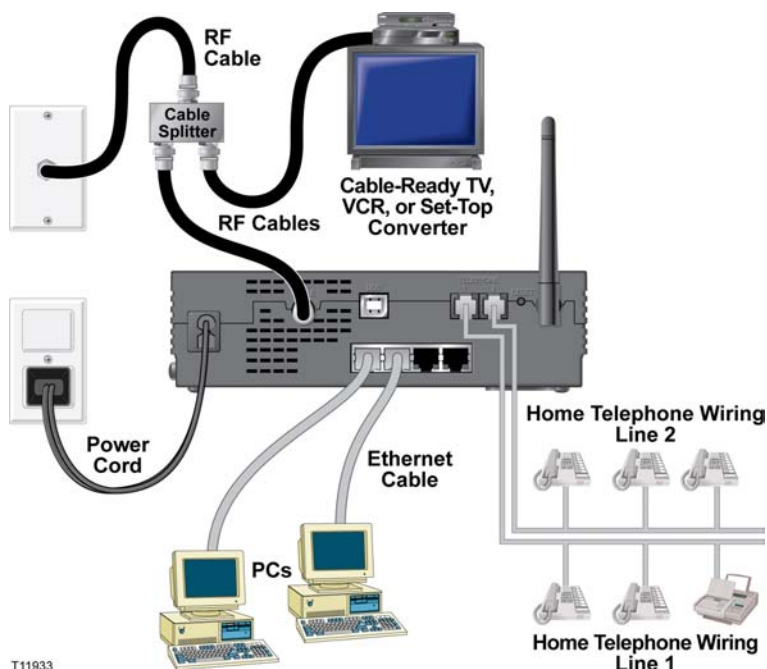

To install the wireless home gateway for telephone service

- 1 Connect a telephone, fax machine, or analog modem to each of the appropriate RJ-11 ports on the wireless home gateway.

Notes:

- The wireless home gateway provides one line of telephone service on each of the RJ-11 connectors.
 - Service must be set up and enabled by the telephone service provider.
 - The two center conductors (pins 3 and 4) on the RJ-11 connector provide electrical connections to directly attached telephone devices or to a permanently installed in-home telephone wiring network.
 - The telephone port labeled Line 1 also supports multi-line telephone devices. Line 1 is supported on pins 3 and 4, and Line 2 is supported on pins 2 and 5.
 - The use of telephones that require electrical connections to other RJ-11 pins requires an adapter.
- 2 After all telephone connections are complete, insert the AC power cord into the power connector on the back of the wireless home gateway, and then plug the cord into an AC power source.

How Do I Install the Modem for Telephone Service?

- 3 Connect the active RF coaxial cable to the **CABLE** connector on the back of the wireless home gateway. The wireless home gateway begins an automatic search to locate and sign on to the network that provides the telephone service. This process may take up to 5 minutes. The modem will be ready for use when the **ONLINE** LED status indicator on the front panel stops blinking and illuminates continuously

Note: Use an optional cable signal splitter to add a TV, a DHCT or set-top converter, or a VCR.

- 4 Test your telephone service by lifting the receiver of each attached telephone to verify that the dial tone can be heard and that you can make and receive telephone calls. This process may take several minutes.

Notes:

- The **TEL 1** and **TEL 2** LED status indicators on the front panel of the wireless home gateway *illuminate* when telephony service is enabled.
- The **TEL 1** or the **TEL 2** LED status indicators on the front panel of the wireless home gateway *blink* when the attached device is “off the hook.”

How Do I Maintain the Batteries?

Your modem includes up to two rechargeable Lithium-Ion batteries to provide stand-by operation in the event of an AC power failure. You can replace one or both of the batteries without the use of any tools.



WARNING:

There is danger of explosion if the battery is mishandled or incorrectly replaced. Replace only with the same type of battery. Do not disassemble it or attempt to recharge the battery outside the system. Do not crush, puncture, dispose of in a fire, short external contacts, or expose to water or other liquids. Dispose of the battery in accordance with local regulations and instructions from your service provider.

Charging the Batteries

The batteries begin to charge automatically as soon as you attach the modem to the AC electrical outlet. When you first plug in the modem, the **POWER** LED status indicator illuminates.

Important! It may take as long as 24 hours for each battery to charge fully.

Using the Modem Without a Battery

If you want, you can use the modem without a battery. If you need to remove the batteries, follow the procedures found in *Removing and Replacing the Batteries* (on page 49), later in this section.

Important! If you choose to operate your modem without a battery, you risk losing your telephone service during a power outage.

Replacing the Batteries

Under normal circumstances, the battery should last for several years. The **BATTERY** LED status indicator turns off to indicate that the battery should be replaced soon. Contact your service provider to obtain replacement batteries and for disposal instructions.

Note: Follow the steps found in *Removing and Replacing the Batteries* (on page 49), to remove and replace one or both of the batteries.

Location of Batteries

The following illustration shows the location of the batteries on the wireless home gateway.

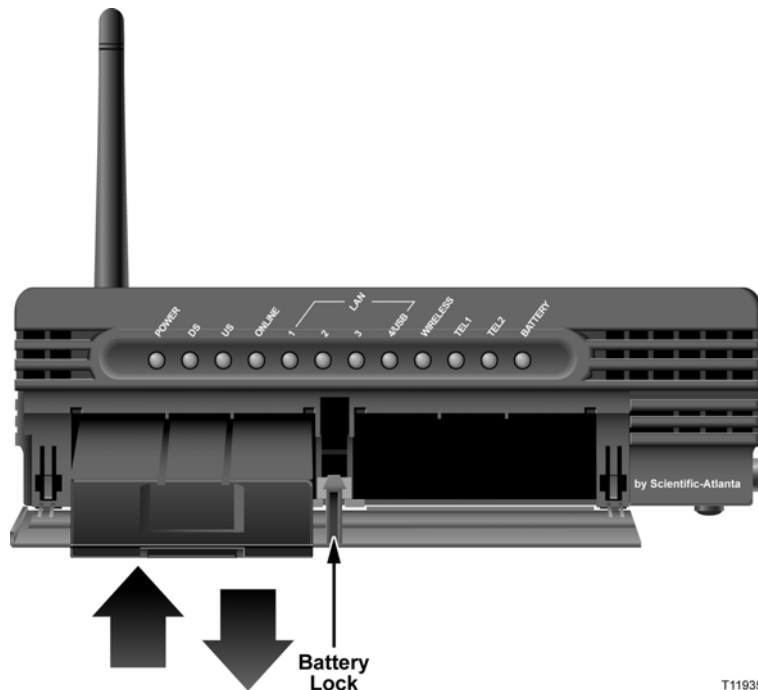

Removing and Replacing the Batteries

Follow these steps to remove and replace one or both of the batteries. You can remove and replace the batteries without disconnecting the AC power source.

- 1 Gently press the battery cover on the front of the modem to open the battery cover and gain access to the battery compartment.
- 2 Slide the battery lock upward (toward the front panel LEDs) to disengage the battery lock.
- 3 Grasp the plastic strip on the front of the battery and gently slide the battery forward to remove it from the battery compartment.
- 4 Insert a new battery into the battery compartment.
- 5 Repeat steps 3 and 4 if you are replacing both batteries. Then, go to step 6.
- 6 Close the battery compartment door. The battery lock will automatically engage.

Important! It may take as long as 24 hours for each battery to charge fully.

Note: Dispose of the battery in accordance with local regulations and instructions from your service provider.

How Do I Mount the Modem on a Wall? (Optional)

You can mount the wireless home gateway on a wall using two wall anchors, two screws, and the mounting slots located on the unit. The modem can be mounted vertically or horizontally.

Before You Begin

Before you begin, choose an appropriate mounting place. The wall can be made of cement, wood, or drywall. The mounting location should be free of obstructions on all sides, and the cables should be able to easily reach the wireless home gateway without strain. Leave sufficient clearance between the bottom of the wireless home gateway and any flooring or shelving underneath to allow access to cabling. In addition, leave enough slack in all cables so that the wireless home gateway can be removed for any required maintenance without disconnecting the cables. Also, verify that you have the following items:

- Two wall anchors for #8 x 1 inch screws
- Two #8 x1 inch pan head sheet metal screws
- Drill with a 3/16-in. wood or masonry bit, as appropriate for the wall composition
- A copy of the wall-mounting illustrations shown on the following pages

How Do I Mount the Modem on a Wall? (Optional)

Mount the modem as shown in the following illustration.

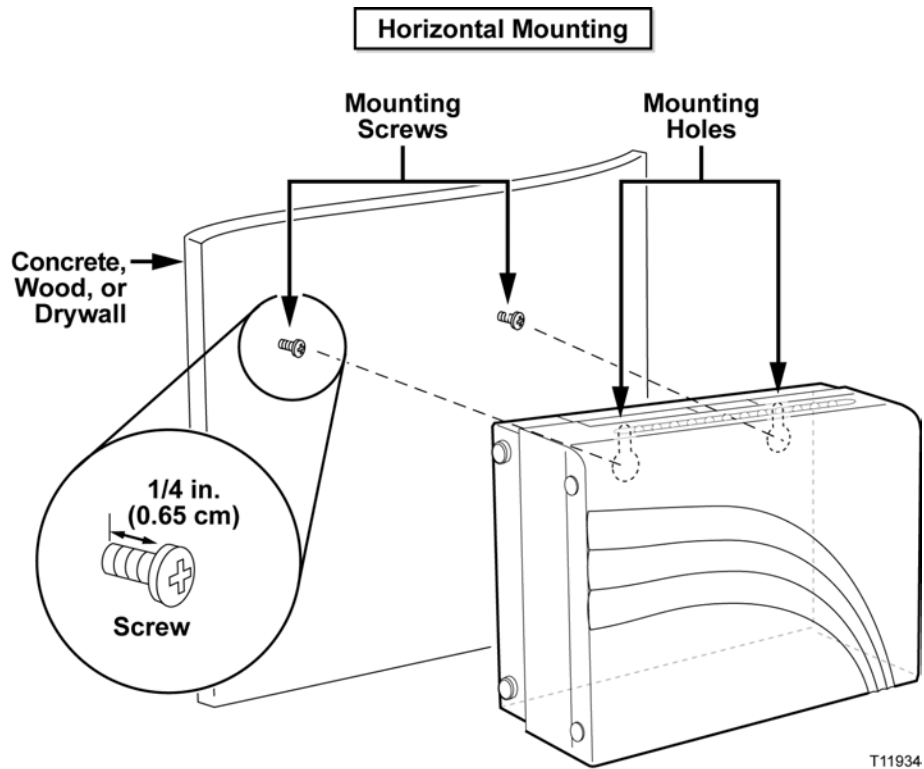

How Do I Mount the Modem on a Wall? (Optional)

Location and Dimensions of the Wall-Mounting Slots

The following illustration shows the location and dimensions of the wall-mounting slots on the bottom of the modem. Use the information on this page as a guide for mounting your modem to the wall.

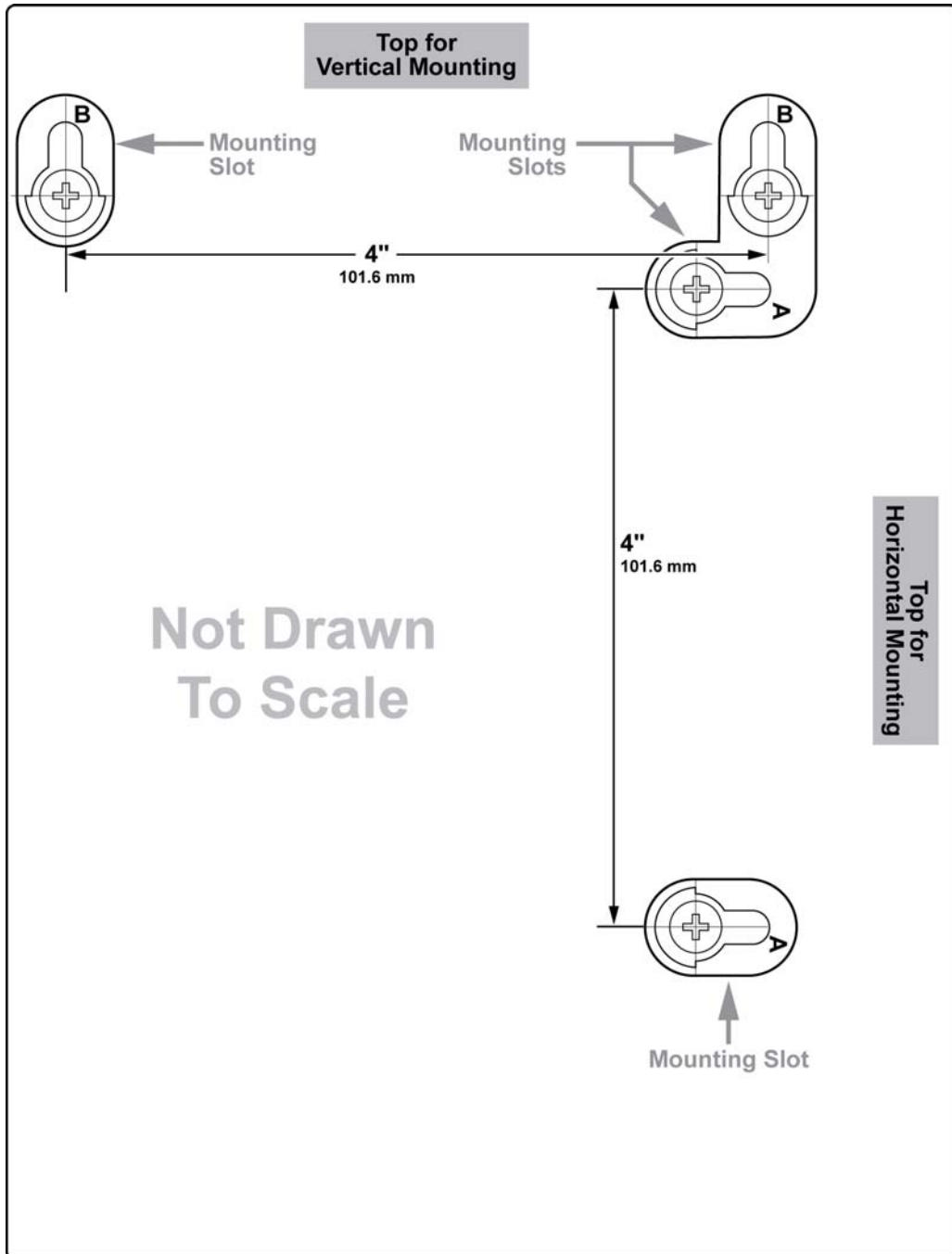

T12752

Mounting the Wireless Home Gateway on a Wall

To mount the wireless home gateway on a wall

Complete these steps to mount the wireless home gateway on the wall.

- 1 Using a drill with a 3/16-in. bit, drill two holes in the wall as follows:
 - To mount the wireless home gateway vertically, drill the holes at the same height and 4 inches apart.
 - To mount the wireless home gateway horizontally, drill the holes at the same height and 4 inches apart.

Note: The graphic on the preceding page illustrates the location of the mounting holes on the back of the wireless home gateway.

- 2 Are you mounting the wireless home gateway into a drywall or concrete surface where a wooden stud is available?
 - If **no**, drive the anchor bolts into the wall, and install the mounting screws into the anchor bolts leaving a gap of about 1/4-in. between the screw head and the wall. Then, go to step 4.
 - If **yes**, go to step 3.
- 3 Install the mounting screws into the wall leaving a gap of about 1/4-in. between the screw head and the wall. Then, go to step 4.
- 4 Verify that no cables or wires are connected to the wireless home gateway.
- 5 Lift the wireless home gateway into position. Slip the large end of both mounting slots (located in the back of the wireless home gateway) over the mounting screws, then slide the wireless home gateway down until the narrow end of the keyhole slot contacts the screw shaft.

Important! Verify that the mounting screws securely support the wireless home gateway before you release the unit.

How Do I Configure the Wireless Home Gateway?

To configure your wireless home gateway, you must first access the WebWizard configuration pages. This section provides detailed instructions and procedures for accessing the WebWizard pages and for configuring your wireless home gateway to operate correctly. This section also presents examples and descriptions of each WebWizard configuration page. Use the WebWizard pages to customize your wireless home gateway to your needs rather than using the default settings.

Important! The WebWizard pages and the examples shown in this section are for illustration purposes only. Your pages may differ from the pages shown in this guide.

Note: If you are not familiar with the network configuration procedures detailed in this section, contact your cable service provider before you attempt to change any of the wireless home gateway default settings.

Accessing the Wireless Home Gateway

You must access the WebWizard in order to configure the wireless home gateway. To gain access to the WebWizard, use the Web browser on the PC attached to the gateway.

- 1 Open the Web browser on your PC.
- 2 Type the following IP address and then select **Go**:
http://192.168.0.1.
- 3 The Web browser accesses the WebWizard and displays the default **About Your Modem** page. This page displays information about your cable modem along with a series of tabs for accessing other WebWizard configuration and operation features.

Note: The **About Your Modem** page is accessible only when the modem is offline. This page is used to provide helpful information during the installation process or when troubleshooting network-related problems. Once the modem is online, the **About Your Modem** page is hidden from view.

About Your Modem Page Example

The following illustration is an example of the About Your Modem page.

Field Name	Description
Name	WebSTAR DPC2434
Modem Serial Number	234567890
Cable Modem MAC Address	00:14:f8:d3:21:d8
Hardware Version	1.0
Software Version	v2.0.2r1262-060529
Receive Power Level	-21.5 dBmV
Transmit Power Level	8.3 dBmV
Cable Modem Status	Not Synchronized

About Your Modem Page Description

The following table provides a description of each field within the About Your Modem page.

Field Name	Description
Name	The name of the wireless home gateway
Modem Serial Number	A unique sequential series of alphanumeric characters provided to every modem during manufacturing
Cable Modem MAC Address	A unique alphanumeric address for the cable modem coaxial interface, which is used to connect to the cable modem termination system (CMTS) at the headend. A media access control (MAC) address is a hardware address that uniquely identifies each node of a network
Hardware Version	Identifies the revision of the circuit board design
Software Version	Identifies the software version placed into the modem at the time of manufacturing
Receive Power Level	The input level of the downstream CMTS carrier
Transmit Power Level	Indicates the upstream power level

How Do I Configure the Wireless Home Gateway?

Field Name	Description
Cable Modem Status	<p data-bbox="662 353 1260 416">Lists one of the following possible current states of the modem:</p> <ul data-bbox="662 439 1260 1034" style="list-style-type: none"><li data-bbox="662 439 1260 472">■ other<li data-bbox="662 483 1260 517">■ notReady<li data-bbox="662 528 1260 562">■ notSynchronized<li data-bbox="662 573 1260 607">■ phySynchronized<li data-bbox="662 618 1260 651">■ usParametersAcquired<li data-bbox="662 663 1260 696">■ rangingComplete<li data-bbox="662 707 1260 741">■ ipComplete<li data-bbox="662 752 1260 786">■ todEstablished<li data-bbox="662 797 1260 831">■ securityEstablished<li data-bbox="662 842 1260 875">■ psrsmTransferComplete<li data-bbox="662 887 1260 920">■ registrationComplete<li data-bbox="662 931 1260 965">■ operational<li data-bbox="662 976 1260 1010">■ accessDenied

Setting Configuration Options

Use the Setup page to access the various configuration options for the wireless home gateway. Detailed descriptions of each configuration option follow later in this guide.

Important! After you click the Setup tab, or whenever you access the WebWizard by typing the 192.168.0.1 IP address into your Web Browser while the gateway is online, an authentication window similar to the following window opens:



To access the Setup page, leave the user name blank and enter your password. Then click **OK** to continue to the Setup page.

Important! If you have not set up a password, leave *both* the User Name and Password field blank and click **OK** to continue to the Setup page.

Note: The gateway ships from the factory without a factory-assigned default password. See *Configuring Your Password Settings* (on page 64) for assistance in setting up your password.

How Do I Configure the Wireless Home Gateway?

Setup Page Example

The following illustration is an example of the Setup page.

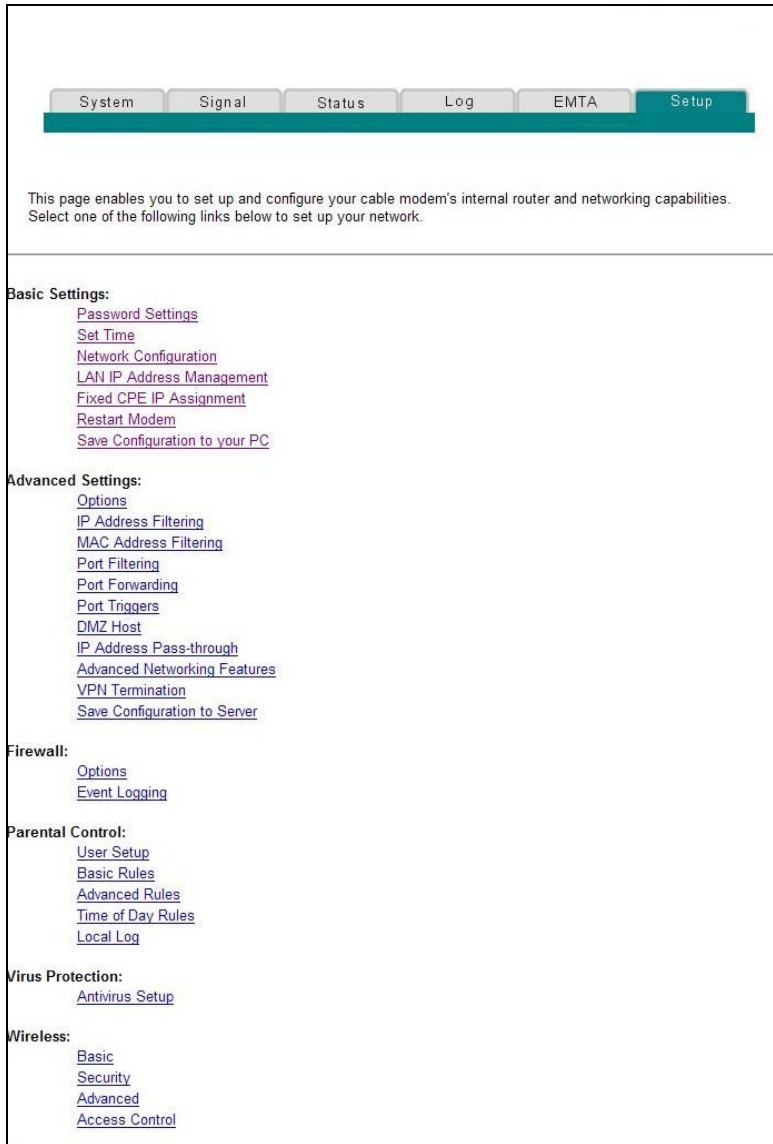

Setup Page Section Headings

The Setup page is divided into the following section headings:

- Basic Settings
- Advanced Settings
- Firewall
- Parental Control

- Virus Protection
- Wireless

In the Setup page, click the selections listed within these sections to access the WebWizard page for that selection. A description of the selections available in each section follows next.

Basic Settings

The following table provides a description of the pages available from within the Basic Settings section of the Setup page.

Field Name	Description
Password Settings	Use this page to set or modify your password settings
Set Time	Use this page to enable or disable time synchronization by Network Time protocol
Network Configuration	Use this page to enter or modify the basic settings for your network
LAN IP Address Management	Use this page to configure how Internet protocol (IP) addresses are assigned and managed in your network
Fixed CPE IP Assignment	Use this page to reserve IP addresses in the DHCP pool that will be used as static IP addresses in your local network.
Restart Modem	Use this page to restart your wireless home gateway
Save Configuration to your PC	Use this page to save your cable modem RG configuration to your local PC and to restore the RG configuration to your wireless home gateway, if necessary

How Do I Configure the Wireless Home Gateway?

Advanced Settings

The following table provides a description of the pages available from within the Advanced Settings section of the Setup page.

Field Name	Description
Options	Use this page to enable or disable advanced features on your network
IP Address Filtering	Use this page to configure IP address filters. These filters prevent designated IP addresses from accessing the Internet
MAC Address Filtering	Use this page to configure MAC address filters. These filters prevent designated MAC addresses from accessing the Internet
Port Filtering	Use this page to configure transmission control protocol (TCP) and user datagram protocol (UDP) port filters. These filters prevent a range of TCP/UDP ports from accessing the Internet
Port Forwarding	Use this page to configure port forwarding for local IP addresses. Port forwarding allows you to run a server on the local area network (LAN) by specifying the mapping of TCP/UPD ports to local PCs or to the IP address of other devices. This is a static setting that holds the ports open at all times
Port Triggers	Use this page to configure TCP/UPD port triggers. Port triggering is similar to port forwarding, but is a dynamic function. In other words, the ports are not held open, and the ports close if no outgoing data is detected on the selected ports for a period of 10 minutes

How Do I Configure the Wireless Home Gateway?

Field Name	Description
DMZ Host (Demilitarized Zone)	<p>Use this page to configure an IP address that is visible to the wide area network (WAN). DMZ hosting is commonly referred to as “exposed host,” and allows you to specify the “default” recipient of WAN traffic that Network Address Translation (NAT) is unable to translate to a known local PC.</p> <p>A DMZ is used by a company that wants to host its own Internet services without sacrificing unauthorized access to its private network. DMZ allows one IP address to be unprotected while others remain protected. The DMZ is located between the Internet and an internal network's line of defense that is a combination of firewalls and bastion hosts.</p> <p>Typically, the DMZ contains devices accessible to Internet traffic, such as Web (HTTP) servers, FTP servers, SMTP (e-mail) servers, and domain name system (DNS) servers</p>
IP Address Pass-through	<p>Allows the user with network administrator access to designated MAC addresses of CPE devices in the private LAN network to be assigned public IP addresses instead of private IP addresses.</p> <p>Note: This link is displayed when the user enters the Network Administrator User Name and Password. This link is not displayed during normal user access.</p>
Advanced Networking Features	<p>Allows the user with network administrator access to enable advanced networking features including RIP and support for up to 3 routed subnets on the private network.</p> <p>Note: This link is displayed when the user enters the Network Administrator User Name and Password. This link is not displayed during normal user access.</p>
VPN Termination	<p>Use this page to enable VPN protocols and manage VPN tunnels.</p> <p>Note: This link is displayed when the user enters the Network Administrator User Name and Password. This link is not displayed during normal user access.</p>
Save Configuration to Server	<p>Allows the user with network administrator access to save the configuration profile of the gateway to a TFTP server in the network. Once the profile is saved to a server, the configuration file can be downloaded and used to restore all the router settings of the gateway.</p> <p>Note: This link is displayed when the user enters the Network Administrator User Name and Password. This link is not displayed during normal user access.</p>

How Do I Configure the Wireless Home Gateway?

Firewall

The following table provides a description of the pages available from within the Firewall section of the Setup page.

Field Name	Description
Options	Use this page to configure Web page filtering and firewall protection
Event Logging	Use this page to access the firewall event log and to enter your e-mail address in order to receive e-mail alerts related to firewall attacks by hackers

Parental Control

The following table provides a description of the pages available from within the Parental Control section of the Setup page.

Field Name	Description
User Setup	Use this page to add or delete user profiles and to apply access rules to those users
Basic Rules	Use this page to setup access rules that block certain Internet content and certain Web sites
Advanced Rules	Use this page to configure parental control associated with a content rating service
Time of Day Rules	Use this page to configure Web access filters to block all Internet traffic to and from specific network devices based on time of day settings that you select
Local Log	Use this page to view events captured by Parental Control event log feature

Virus Protection

The following table provides a description of the pages available from within the Virus Protection section of the Setup page.

Field Name	Description
Antivirus Setup	Use this page to access a Web site that allows you to download a free evaluation copy of antivirus software to be installed on all PCs or computers connected to the wireless home gateway

Wireless

The following table provides a description of the pages available from within the Wireless section of the Setup page.

Field Name	Description
Basic	Use this page to configure your wireless access point (WAP) parameters, including service set identifier (SSID) and channel number
Security	Use this page to configure your WAP authentication and data encryption. Using encryption and authentication prevents unauthorized access to your wireless devices
Advanced	Use this page to configure your WAP data rates and wireless fidelity (WiFi) thresholds
Access Control	Use this page to configure the WAP to restrict access to only selected wireless client devices. Authorized clients are selected by MAC address. Use this page to select Open System or Share Key authentication and to enable and disable broadcast of the WAP SSID

Configuring Your Password Settings

Use the Basic Settings - Password Settings page to set up a password to restrict unauthorized persons from accessing to your wireless home gateway settings. Click **Password Settings** in the Basic Settings section of the Setup page to access the Password Settings page.

Notes:

- Your gateway modem comes from the factory with no password enabled. We highly recommend that you set up a user password to prevent unauthorized users from modifying the settings of your network.
- If you do choose to set up a password, use a password that you can easily remember. Do *not* forget your password.

Setup Basic Settings - Password Settings Page Example

The following illustration is an example of the Basic Settings - Password Settings page.

System Signal Status Log EMTA Setup

Setup
Basic Settings - Password Settings
This page allows you to modify the password settings for this device.

Password

Re-Enter Password

Apply

To set up your password

To set up your password, type your password in the Password field, and then re-type your password in the Re-Enter Password field. Then, click **Apply** to save your password.

Note: If you set a password, on subsequent access to the WebWizard pages, a screen similar to the following appears. Do *not* forget your password. Write your password and store it in a secure location known only to you.

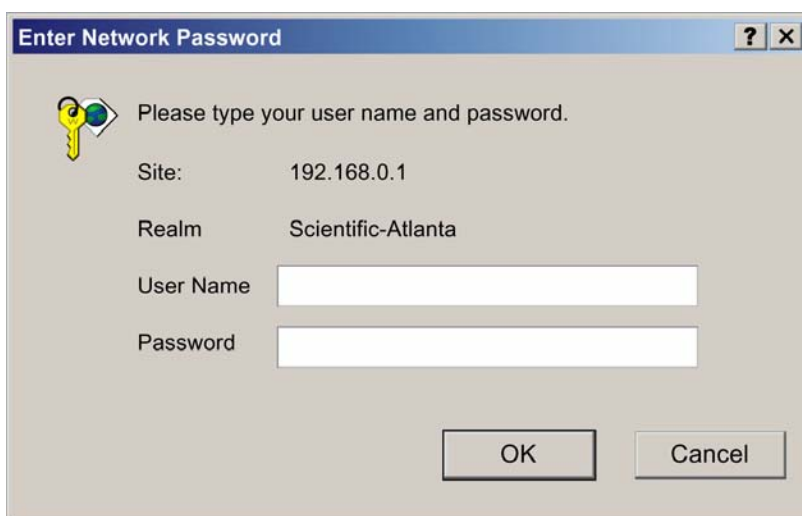

Enter Network Password

Please type your user name and password.

Site: 192.168.0.1

Realm Scientific-Atlanta

User Name

Password

OK Cancel

Configuring Network Time Synchronization

Use the Basic Settings Enable/Disable time synchronization by Network Time protocol page to enable or disable time synchronization by Network Time protocol.

Note: If you are not familiar with the time configuration procedures detailed in this section, contact your cable service provider before you attempt to change any of the wireless home gateway default time synchronization configuration settings.

Click **Set Time** in the Basic Settings section of the Setup page to access the Basic Settings Enable/Disable time synchronization by Network Time protocol page.

Setup Basic Settings - Enable/Disable Time Synchronization by Network Time Protocol Page Example

The following illustration is an example of the Basic Settings Enable/Disable time synchronization by Network Time protocol page.

The screenshot shows a web interface with a navigation bar at the top containing tabs for System, Signal, Status, Log, EMTA, and Setup. The Setup tab is selected and highlighted in teal. Below the navigation bar, the page title is "Setup" followed by "Basic Settings - Enable/Disable time synchronization by Network Time protocol". A subtitle reads: "This page allow you to enable or disable time synchronization by Network Time protocol." The main configuration area includes: "Current System Time" set to "Thu Jan 01 00:11:20 1970"; "Network Time Protocol" with radio buttons for "Enable" and "Disable", where "Disable" is selected; "Latest Update Success" shown as a series of dashes; "Time Zone" set to "(GMT) Greenwich Mean Time : Dublin, Edinburgh, Lisbon, London" in a dropdown menu; "Daylight Saving Time" set to "60" minutes with an "Enable" checkbox that is unchecked. An "Apply" button is located below these settings. At the bottom, there is a "Time Server" section with an empty input field and an "Add Server" button. Below this, a list of servers is shown: "time.nist.gov", "nist.aol-ca.truetime.com", and "nist1-ny.glassey.com", with a "Remove Server" button to the right.

Setup Basic Settings - Enable/Disable Time Synchronization by Network Time Protocol Page Description

The following table provides a description of the fields within the Basic Settings Enable/Disable time synchronization by Network Time protocol page.

Field Name	Description
Current System Time	Displays the current system time and date
Network Time Protocol	Allows you to enable or disable network time protocol Note: The gateway will automatically use the time server in your broadband network. Should there be no current time displayed or if the network time is incorrect, enable Network Time Protocol to use a public Internet time server to set the clock in the gateway.
Latest Update Success	Displays the time and date of the last successful time update
Time Zone	Displays the current time zone. The drop-down list allows you to select your local time zone.
Daylight Saving Time	Allows you to adjust the time during periods when Daylight Saving Time is in effect. Check the Enable box to enable or disable this setting. Note: If the offset for Daylight Savings Time is other than 60 minutes, enter the offset in the minutes field.
Time Server	Add and delete time server URLs or IP addresses to and from the list, as required. When using Network Time Protocol, multiple time servers can be specified for the gateway to query for time of day. The gateway will sequentially step through the listed time servers until it acquires the current time. There are three well known public time servers entered as default servers.

Function Keys

Key	Description
Apply	Saves all additions, edits, and changes
Add Server	Allows you to add a network time server
Remove Server	Allows you to remove a network time server

How Do I Configure the Wireless Home Gateway?

Configuring the Default Network Settings

You can use the default network settings, or, if your system requires different settings to operate correctly, you can change the default network settings using the Setup Basic Settings - Network Configuration page.

Note: If you are not familiar with the network configuration procedures detailed in this section, contact your cable service provider before you attempt to change any of the wireless home gateway default network configuration settings.

Click **Network Configuration** in the Basic Settings section of the Setup page to access the Setup Basic Settings - Network Configuration page.

Setup Basic Settings - Network Configuration Page Example

The following illustration is an example of the Setup Basic Settings - Network Configuration page.

System	Signal	Status	Log	EMTA	Setup
--------	--------	--------	-----	------	-------

Setup
Basic Settings - Network Configuration
 This page allows you to enter or modify the basic settings for your network.

LAN IP Address:	<input type="text" value="192"/> . <input type="text" value="168"/> . <input type="text" value="0"/> . <input type="text" value="1"/>
MAC Address	00:14:f8:d3:21:db
WAN IP Address:	---.---.---.---
Subnet Mask:	---.---.---.---
Gateway IP:	---.---.---.---
Duration	D: -- H: -- M: -- S: --
Expires	---:---:---:---
	<input type="button" value="Renew WAN IP Address Lease"/> <input type="button" value="Apply"/>
Host Name	<input type="text"/> (Required by some ISPs)
Domain Name	<input type="text"/> (Required by some ISPs)
Static IP Address	<input type="text" value="0"/> . <input type="text" value="0"/> . <input type="text" value="0"/> . <input type="text" value="0"/>
Static IP Mask	<input type="text" value="0"/> . <input type="text" value="0"/> . <input type="text" value="0"/> . <input type="text" value="0"/>
Default Gateway	<input type="text" value="0"/> . <input type="text" value="0"/> . <input type="text" value="0"/> . <input type="text" value="0"/>
Primary DNS (static IP only)	<input type="text" value="0"/> . <input type="text" value="0"/> . <input type="text" value="0"/> . <input type="text" value="0"/>
Secondary DNS (static IP only)	<input type="text" value="0"/> . <input type="text" value="0"/> . <input type="text" value="0"/> . <input type="text" value="0"/>
	<input type="button" value="Apply"/>

Setup Basic Settings - Network Configuration Page Description

The following table provides a description of the fields within the Setup Basic Settings - Network Configuration page.

Field Name	Description
LAN IP Address	Displays the base IP address of the private home LAN and the WebWizard IP address. Your wireless home gateway assigns private IP addresses to your attached computers by its internal dynamic host configuration protocol (DHCP) server
MAC Address	Displays the MAC address for the WAN. The factory assigned MAC address for the WAN is also referred to as the WLAN Data MAC
WAN IP Address	Displays the public IP address assigned to your gateway by your ISP. The WAN port will be assigned a public IP address automatically by your ISP except when a static IP address is set up as described below. The WAN IP address will be shared by all the PCs in your private local area network to access the Internet
Subnet Mask	Displays the subnet mask for your WAN port. This address is automatically assigned to your WAN port by your ISP except when a static IP address is set up as described later in this table
Gateway IP	Displays a Gateway IP address for your WAN port. This address is automatically assigned to your WAN port by your ISP except when a static IP address is set up as described later in this table
Duration	Displays the length of time your WAN IP address is valid
Expires	Displays the date and time your WAN IP address expires
Host Name	Displays the host name that is usually downloaded to your gateway by your ISP. However, some ISPs require this information to be entered manually. If manual entry is required, your ISP will provide the information for you to enter into this field.
Domain Name	Displays the domain name that is usually downloaded to your gateway by your ISP. However, some ISPs require this information to be entered manually. If manual entry is required, your ISP will provide the information for you to enter into this field.

How Do I Configure the Wireless Home Gateway?

Field Name	Description
Static IP Address	Manual entry is required. Your ISP will provide the information for you to enter into this field. Note: When setting a static IP address, you must enter the IP address, subnet mask, and default gateway before the static IP address will become operational.
Static IP Mask	Manual entry is required. Your ISP will provide the information for you to enter into this field.
Default Gateway	Manual entry is required, your ISP will provide the information for you to enter into this field.
Primary DNS (static IP only)	Manual entry is required. Your ISP will provide the information for you to enter into this field.
Secondary DNS (static IP only)	Manual entry is required. Your ISP will provide the information for you to enter into this field.

Function Keys

The following function keys appear on the Setup Basic Settings - Network Configuration page.

Key	Description
Renew WAN IP Address Lease	Forces a release and renewal of your WAN IP address
Apply	Saves the values you enter into the fields without closing the screen

Configuring and Managing IP Addresses

Use the Setup Basic Settings - IP Management page to configure how your system manages and assigns IP addresses in your network.

Note: If you are not familiar with the IP management procedures detailed in this section, contact your cable service provider before you attempt to change any of the wireless home gateway default IP management settings.

Click **LAN IP Address Management** in the Basic Settings section of the Setup page to access the Setup Basic Settings - IP Management page.

Setup Basic Settings - IP Management Page Example

The following illustration is an example of the Setup Basic Settings - IP Management page.

System Signal Status Log EMTA Setup

Setup

Basic Settings - IP Management

This page allows you to configure how IP addresses are assigned and managed in your network.

DHCP Server Yes No

Starting Local Address 192.168.0.

Number of CPEs

DHCP Client Lease Info				
MAC Address	IP Address	Subnet Mask	Duration	Expires
000d561244e8	192.168.000.010	255.255.255.000	D:00 H:01 M:00 S:00	-----:--:--

Current System Time: -----:--:--

Setup Basic Settings - IP Management Page Description

The following tables provide a description of the fields within the Setup Basic Settings - IP Management page.

Field Name	Description
DHCP Server	Allows you to enable or disable the DHCP server in the wireless home gateway
Starting Local Address	Displays the starting address used by the built-in DHCP server to distribute Private LAN IP addresses. In the example shown, addresses between 2 and 9 can be used for devices on your Private LAN that require fixed IP addresses such as printers or a device assigned as a DMZ host Note: The LAN IP address ending in 1 is reserved for the internal gateway server. The LAN IP address ending in 255 is also reserved and should not be used for CPE devices
Number of CPEs	Enter the maximum number of devices allowed to connect to the Private LAN. Note: The Factory Default is 245. The maximum number of devices is 253. This is the combined total of addresses reserved for static IP addresses, for example, the sum of the IP addresses between 2 and the value entered in the Starting Local Address field and the value entered in the Number of CPEs field. Note: The sum of the value entered in the Starting Local Address field and the value entered in the Number of CPEs field must always be 255 or less.
DHCP Client Lease Info	Displays the MAC address, IP Address, Subnet Mask, Duration and Expiration date of all devices issued an IP address by the built-in DHCP server. This field also displays the current system time and date

Function Keys

The following function keys appear on the Basic Settings - IP Management page.

Key	Description
Apply	Saves the values you enter into the fields without closing the screen
Force Available	Forces the release of an IP address for you to re-use

Reserving IP Addresses

Use the Setup Basic Settings - Fixed CPE IP Assignment page to reserve IP addresses. This feature allows you to assign a fixed IP address to any device in your network by setting static IP addresses in your PC or other network device.

These addresses will be removed from the pool of the IP addresses to be used by your gateway's DHCP server when issuing IP addresses to devices that are connected to your local network.

Reserving IP addresses is useful in making sure that there are no IP address conflicts on the network, for example, two devices using the same IP address. Another example: when using DMZ Host, the IP address for the DMZ Host should always have the same IP address.

Note: If you are not familiar with the Fixed CPE IP Assignment procedures detailed in this section, contact your cable service provider before you attempt to change any of the wireless home gateway default Fixed CPE IP Assignment settings.

Click **Fixed CPE IP Assignment** in the Basic Settings section of the Setup page to access the Setup Basic Settings - Fixed CPE IP Assignment page.

Setup Basic Settings - Fixed CPE IP Assignment Page Example

The following illustration is an example of the Setup Basic Settings - Fixed CPE IP Assignment page.

Setup
Basic Settings - Fixed CPE IP Assignment
 This page allows you to set fixed IP for LAN CPE devices.

MAC Address : : : : : :

Assign to IP : . . .

MAC Address	IP Address	Status
00:0d:56:12:44:e8	<-> 192.168.0.10	Active

Setup Basic Settings - Fixed CPE IP Assignment Page Description

The following tables provide a description of the fields within the Setup Basic Settings - Fixed CPE IP Assignment page.

Field Name	Description
MAC Address	The MAC address of the PC or device (for example, a printer) for which you want to reserve a specific IP address on the network
Assign to IP	The IP address you assign to the PC or device for which you want to reserve a specific IP address on the network. Only MAC addresses within the range of the gateway's DHCP address pool can be reserved with this feature. Note: The factory configuration of your gateway sets aside IP addresses 192.168.0.2 through 192.168.0.9 for static IP addresses.

How Do I Configure the Wireless Home Gateway?

Function Keys

Key	Description
Add Static IP	Adds the Static IP address to the list of assigned IP addresses
Remove Static IP	Removes the Static IP address from the list of assigned IP addresses

Restarting the Gateway Modem

Use the Setup Basic Settings - Restart Cable Modem page to restart your cable modem.

Click **Restart Modem** in the Basic Settings section of the Setup page to access the Basic Settings - Restart Cable Modem page.

Click **Reboot Cable Modem** to restart the gateway modem.

Note: Restarting your gateway modem does not reset any of the settings.

Setup Basic Settings - Restart Cable Modem Page Example

The following illustration is an example of the Restart Cable Modem page.

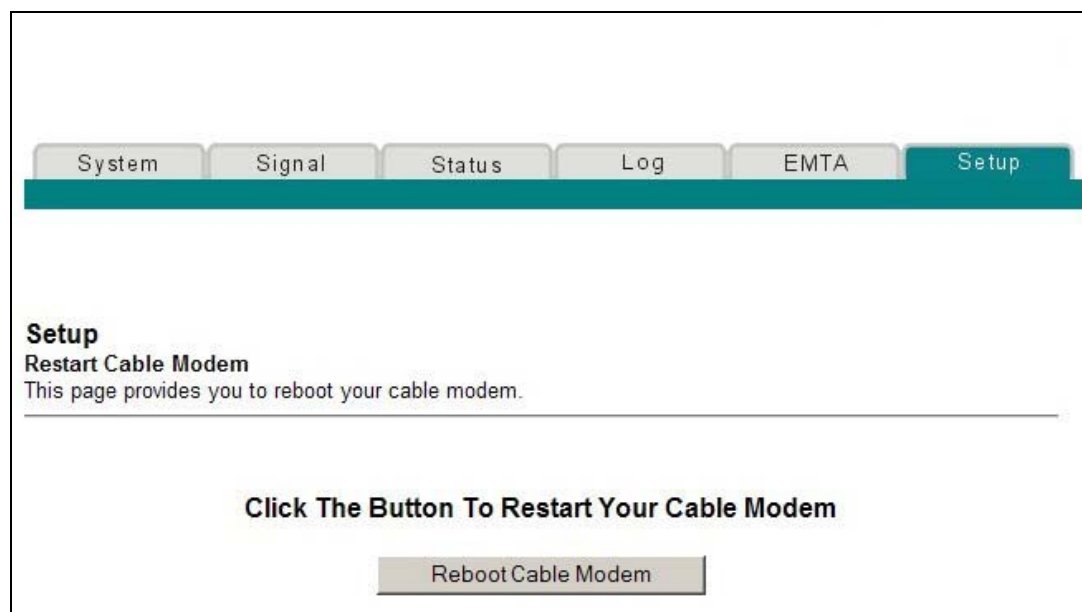

Saving Your Configuration

Use the Setup Basic Settings - Save RG Configuration to Local PC page to save your current cable modem RG configuration to the hard drive on your PC or to a floppy disk. You will then be able to restore the RG configuration, if necessary.

Note: If you are not familiar with the procedures detailed in this section, contact your cable service provider before you attempt to change any of the wireless home gateway default settings.

Click **Save Configuration to your PC** in the Basic Settings section of the Setup page to access the Setup Basic Settings - Save RG Configuration to Local PC page.

Setup Basic Settings - Save RG Configuration to Local PC Page Example

The following illustration is an example of the Setup Basic Settings - Save RG Configuration to Local PC page.

System Signal Status Log EMTA Setup

Save RG Configuration to Local PC

This page provides you with the ability of saving current RG configuration in this device to your Local PC and restoring RG configuration to your device

Download user setting file to your gateway

File Name Browse...

Save current user setting to your computer

 FDD

To **Save** your current setting to your computer, click the floppy disk icon in the lower portion of the screen. You will be prompted to provide a file name and location for the backup configuration file.

To **Restore** your setting, click **Browse** and select the backup configuration file name that you saved on your PC. The path and filename of the backup configuration appears in the File Name field. Then, click **Download** to restore your configuration file. A **Download Success** message appears when the restore is complete.

Enabling and Disabling Advanced Features

Use the Setup Advanced Settings - Options page to enable or disable advanced features on your network. When the wireless interface is disabled, the transmitter is turned off.

Note: If you are not familiar with the advanced settings detailed in this section, contact your cable service provider before you attempt to change any of the wireless home gateway default advanced options settings.

Click **Options** in the Advanced Settings section of the Setup page to access the Setup Advanced Settings - Options page.

Setup Advanced Settings - Options Page Example

The following illustration is an example of the Setup Advanced Settings - Options page.

Feature	Enabled
WAN Blocking	<input checked="" type="checkbox"/> Enable
Isec PassThrough	<input checked="" type="checkbox"/> Enable
PPTP PassThrough	<input checked="" type="checkbox"/> Enable
Remote Config Management	<input type="checkbox"/> Enable
Multicast Enable	<input checked="" type="checkbox"/> Enable
UPnP Enable	<input type="checkbox"/> Enable

Apply

Setup Advanced Settings - Options Page Description

The following table provides a description of the fields within the Setup Advanced Settings - Options page.

Note: If you make changes in the Setup Advanced Settings - Options page, click **Apply** to apply and save your new IP address filter settings.

How Do I Configure the Wireless Home Gateway?

Field Name	Description
WAN Blocking	Checking this box prevents the wireless home gateway from being visible to the WAN. For example, pings to the WAN IP address are not returned
Ipssec PassThrough	Checking this box allows applications that use IPSec (IP Security) to pass through the firewall
PPTP PassThrough	Checking this box allows applications that use Point to Point Tunneling Protocol (PPTP) to pass through the firewall
Remote Config Management	<p>Checking this box enables Remote Configuration Management that allows the user or network operator to view and/or modify the gateway set-up parameters from a location on the WAN, as opposed to the LAN side of the gateway. Access to the set-up parameters is obtained by using the password to access the WebWizard.</p> <p>Enable this feature by checking the Remote Config Management box on the Setup Advanced Settings - Options page. To access your gateway from a remote location, you must also know the WAN IP address of the gateway. To find the WAN IP address, go to the Network Configuration page under Basic Settings. You will find the gateway's WAN IP address list on this page.</p> <p>Enter the WAN IP address of your gateway into the address field of any Web browser using the following format: <code>http://xxx.xxx.xxx.xxx:8080</code> where xxx.xxx.xxx.xxx represents the WAN IP address of your gateway.</p> <p>Be sure to follow the syntax exactly, and then click Go or press Enter. Your gateway Web pages will appear on the remote computer. You will still need to enter your password to access the Setup pages of your gateway</p> <p>Note: If you choose to enable (check) this feature, be sure to set up a user password to prevent unauthorized access to your gateway settings.</p>
Multicast Enable	Checking this box allows multicasts to pass from the WAN side through to the private network
UPnP Enable	Checking this box enables Universal Plug and Play features

Configuring IP Address Filters

Use the Setup Advanced Settings - IP Filtering page to configure IP address filters. These filters block a range of IP addresses from accessing the Internet.

Note: If you are not familiar with the advanced settings detailed in this section, contact your cable service provider before you attempt to change any of the wireless home gateway default advanced IP filtering settings.

Click **IP Address Filtering** in the Advanced Settings section of the Setup page to access the Setup Advanced Settings - IP Filtering page.

Setup Advanced Settings - IP Filtering Page Example

The following illustration is an example of the Setup Advanced Settings - IP Filtering page.

IP Filtering		
Start Address	End Address	Enable
192.168.0.0	192.168.0.0	<input type="checkbox"/>
192.168.0.0	192.168.0.0	<input type="checkbox"/>
192.168.0.0	192.168.0.0	<input type="checkbox"/>
192.168.0.0	192.168.0.0	<input type="checkbox"/>
192.168.0.0	192.168.0.0	<input type="checkbox"/>
192.168.0.0	192.168.0.0	<input type="checkbox"/>
192.168.0.0	192.168.0.0	<input type="checkbox"/>
192.168.0.0	192.168.0.0	<input type="checkbox"/>
192.168.0.0	192.168.0.0	<input type="checkbox"/>
192.168.0.0	192.168.0.0	<input type="checkbox"/>

Apply

Setup Advanced Settings - IP Filtering Page Description

Use this page to specify and enable a range of IP addresses that cannot have access to the Internet. Click **Apply** to apply and save your new IP address filter settings.

Configuring MAC Address Filters

Use the Setup Advanced Settings - MAC Filtering page to configure MAC address filters. These filters allow you to deny or block access to the Internet by the individual MAC addresses listed in the table. You can also prevent individual PCs from sending outgoing TCP/UDP traffic to the WAN using their MAC address.

Note: If you are not familiar with the advanced settings detailed in this section, contact your cable service provider before you attempt to change any of the wireless home gateway default advanced MAC filtering settings.

Click **MAC Address Filtering** in the Advanced Settings section of the Setup page to access the Setup Advanced Settings - MAC Filtering page.

Setup Advanced Settings - MAC Filtering Page Example

The following illustration is an example of the Setup Advanced Settings - MAC Filtering page.

Setup
Advanced Settings - MAC Filtering
This page allows you to configure MAC address filters.

Block Listed ▾

MAC Address Filters	
MAC 01	00 : 00 : 00 : 00 : 00 : 00
MAC 02	00 : 00 : 00 : 00 : 00 : 00
MAC 03	00 : 00 : 00 : 00 : 00 : 00
MAC 04	00 : 00 : 00 : 00 : 00 : 00
MAC 05	00 : 00 : 00 : 00 : 00 : 00
MAC 06	00 : 00 : 00 : 00 : 00 : 00
MAC 07	00 : 00 : 00 : 00 : 00 : 00
MAC 08	00 : 00 : 00 : 00 : 00 : 00
MAC 09	00 : 00 : 00 : 00 : 00 : 00
MAC 10	00 : 00 : 00 : 00 : 00 : 00
MAC 11	00 : 00 : 00 : 00 : 00 : 00
MAC 12	00 : 00 : 00 : 00 : 00 : 00
MAC 13	00 : 00 : 00 : 00 : 00 : 00
MAC 14	00 : 00 : 00 : 00 : 00 : 00
MAC 15	00 : 00 : 00 : 00 : 00 : 00
MAC 16	00 : 00 : 00 : 00 : 00 : 00
MAC 17	00 : 00 : 00 : 00 : 00 : 00
MAC 18	00 : 00 : 00 : 00 : 00 : 00
MAC 19	00 : 00 : 00 : 00 : 00 : 00
MAC 20	00 : 00 : 00 : 00 : 00 : 00

Apply

Setup Advanced Settings - MAC Filtering Page Description

Use this page to enter the MAC address or MAC addresses of devices whose Internet access you want to control. Click **Apply** to apply and save your new MAC address filter settings.

Setting Up MAC Address Filters

The Block/Pass drop down menu allows you to block or pass Internet access to the MAC addresses of the devices you list in the MAC Address Filters table. The following table describes the function of the Block/Pass drop down menu.

Field Name	Description
Block Listed (Default)	Select Block to deny Internet access to the MAC addresses of the devices you list in the table. All other MAC addresses will be allowed Internet access.
Pass	Select Pass to allow Internet access only to the MAC addresses of the devices you list in the table. Any MAC addresses <i>not</i> listed in the table will be denied Internet access.

Configuring and Enabling TCP and UDP Port Filters

Use the Setup Advanced Settings - Port Filtering page to configure and enable TCP and UDP port filters. These filters prevent a range of TCP/UDP ports from accessing the Internet. You can also prevent PCs from sending outgoing TCP/UDP traffic to the WAN on specific IP port numbers. This filter is not IP address- or MAC address-specific. The system blocks the specified port ranges for all PCs.

Note: If you are not familiar with the advanced settings detailed in this section, contact your cable service provider before you attempt to change any of the wireless home gateway default advanced port filtering settings.

Click **Port Filtering** in the Advanced Settings section of the Setup page to access the Setup Advanced Settings - Port Filtering page.

Setup Advanced Settings - Port Filtering Page Example

The following illustration is an example of the Setup Advanced Settings - Port Filtering page.

Setup
Advanced Settings - Port Filtering
This page allows you to configure TCP and UDP port filters.

Start Port	End Port	Protocol	Enable
1	65535	Both	<input type="checkbox"/>
1	65535	Both	<input type="checkbox"/>
1	65535	Both	<input type="checkbox"/>
1	65535	Both	<input type="checkbox"/>
1	65535	Both	<input type="checkbox"/>
1	65535	Both	<input type="checkbox"/>
1	65535	Both	<input type="checkbox"/>
1	65535	Both	<input type="checkbox"/>
1	65535	Both	<input type="checkbox"/>
1	65535	Both	<input type="checkbox"/>

Apply

Setup Advanced Settings - Port Filtering Page Description

Use this page to enter and enable the desired port filtering ranges and protocols in the appropriate fields and then click **Apply** to apply and save your new port filtering settings.

Configuring Port Forwarding for Local IP Addresses

Use the Setup Advanced Settings - Port Forwarding page to configure port forwarding for local IP addresses. Port forwarding allows you to run a server on the LAN by specifying the mapping of TCP/UDP ports to a local PC. You must also set up a fixed private LAN IP address for the destination device.

Note: If you are not familiar with the advanced settings detailed in this section, contact your cable service provider before you attempt to change any of the wireless home gateway default advanced port forwarding settings.

Click **Port Forwarding** in the Advanced Settings section of the Setup page to access the Setup Advanced Settings - Port Forwarding page.

Setup Advanced Settings - Port Forwarding Page Example

The following illustration is an example of the Setup Advanced Settings - Port Forwarding page.

Setup
Advanced Settings - Port Forwarding
This page allows you to configure port forwarding for local IP addresses.

Port Forwarding				
Local IP Adr	Start Port	End Port	Protocol	Enable
192.168.0. <input type="text" value="0"/>	<input type="text" value="0"/>	<input type="text" value="0"/>	Both ▾	<input type="checkbox"/>
192.168.0. <input type="text" value="0"/>	<input type="text" value="0"/>	<input type="text" value="0"/>	Both ▾	<input type="checkbox"/>
192.168.0. <input type="text" value="0"/>	<input type="text" value="0"/>	<input type="text" value="0"/>	Both ▾	<input type="checkbox"/>
192.168.0. <input type="text" value="0"/>	<input type="text" value="0"/>	<input type="text" value="0"/>	Both ▾	<input type="checkbox"/>
192.168.0. <input type="text" value="0"/>	<input type="text" value="0"/>	<input type="text" value="0"/>	Both ▾	<input type="checkbox"/>
192.168.0. <input type="text" value="0"/>	<input type="text" value="0"/>	<input type="text" value="0"/>	Both ▾	<input type="checkbox"/>
192.168.0. <input type="text" value="0"/>	<input type="text" value="0"/>	<input type="text" value="0"/>	Both ▾	<input type="checkbox"/>
192.168.0. <input type="text" value="0"/>	<input type="text" value="0"/>	<input type="text" value="0"/>	Both ▾	<input type="checkbox"/>
192.168.0. <input type="text" value="0"/>	<input type="text" value="0"/>	<input type="text" value="0"/>	Both ▾	<input type="checkbox"/>
192.168.0. <input type="text" value="0"/>	<input type="text" value="0"/>	<input type="text" value="0"/>	Both ▾	<input type="checkbox"/>

Setup Advanced Settings - Port Forwarding Page Description

The following example illustrates how to use the port forwarding feature to configure the Microsoft X-Box Online Live for Internet gaming.

Note: For most widely used applications (including Microsoft X-Box Online Live), the built-in firewall automatically maps and opens ports required for that application while the application is in use.

1. Set the device to be used for port forward to a fixed IP address, for example, **192.168.0.5**.
2. In the first entry of the Port Forwarding area of the page, enter the same IP address (192.168.0.5) in the Local IP Address field.
3. In the same row, enter the appropriate port numbers in the Start Port and End Port fields.
4. In the same row, select the appropriate protocol from the drop-down list in the Protocol field, and then select the box in the **Enable** field.
5. To add additional ports, repeat steps 1 through 4, and then go to step 6.
6. Click **Apply** to apply and save your new port forwarding settings.

Configuring TCP/UDP Port Triggers

Use the Setup Advanced Settings - Port Triggers page to configure TCP/UDP port triggers. Port triggering is similar to port forwarding but is dynamic. In other words, the system does not hold the ports open indefinitely. For example, when the wireless home gateway detects outgoing data on a specific IP port number set in the "Trigger Range," the resulting ports set in the "Target Range" will open for incoming data. If the system detects no outgoing traffic on the "Trigger Range" ports for a period of 10 minutes, the "Target Range" ports close. This is a safer method for opening specific ports for special applications, such as, video conferencing programs, interactive gaming, and file transfer in chat programs. This is safe because the ports are dynamically triggered and not held open continuously or left open erroneously by the router administrator. Therefore, these ports are not exposed and vulnerable for potential hackers to discover.

Note: If you are not familiar with the advanced settings detailed in this section, contact your cable service provider before you attempt to change any of the wireless home gateway default advanced port triggers settings.

Click **Port Triggers** in the Advanced Settings section of the Setup page to access the Setup Advanced Settings - Port Triggers page.

Setup Advanced Settings - Port Triggers Page Example

The following illustration is an example of the Setup Advanced Settings - Port Triggers page.

Setup
Advanced Settings - Port Triggers
This page allows you to configure TCP/UDP port triggers.

Port Triggering					
Trigger Range		Target Range			
Start Port	End Port	Start Port	End Port	Protocol	Enable
0	0	0	0	Both	<input type="checkbox"/>
0	0	0	0	Both	<input type="checkbox"/>
0	0	0	0	Both	<input type="checkbox"/>
0	0	0	0	Both	<input type="checkbox"/>
0	0	0	0	Both	<input type="checkbox"/>
0	0	0	0	Both	<input type="checkbox"/>
0	0	0	0	Both	<input type="checkbox"/>
0	0	0	0	Both	<input type="checkbox"/>
0	0	0	0	Both	<input type="checkbox"/>
0	0	0	0	Both	<input type="checkbox"/>

Apply

Setup Advanced Settings - Port Triggers Page Description

Use this page to enter and enable the port forwarding trigger and target range start and end ports along with protocol information in the appropriate fields. The following example illustrates how to use the port triggering feature to configure the Microsoft X-Box Online Live for Internet gaming.

Note: For most widely used applications (including Microsoft X-Box Online Live), the built-in firewall automatically maps and opens ports required for that application while the application is in use.

1. In the first row, enter **88** in both Start Port and End Port fields.
2. In the same row, select **UDP** from the drop-down list in the Protocol field, and then select the box in the **Enable** field.
3. In the second row, enter **3074** in both Start Port and End Port fields.
4. In the same row as the second entry, select **Both**, and then select the box in the Enable field.
5. Click **Apply** to apply and save your new port forwarding settings.

Configuring the DMZ Host

Use the Setup Advanced Settings - DMZ Host page to configure an IP address that is visible to the WAN. DMZ hosting is commonly referred to as “exposed host,” and allows you to specify the “default” recipient of WAN traffic that Network Address Translation (NAT) is unable to translate to a known local PC. DMZ allows one IP address to be unprotected while others remain protected.

Note: If you are not familiar with the advanced settings detailed in this section, contact your cable service provider before you attempt to change any of the wireless home gateway default advanced DMZ host settings.

Click **DMZ Host** in the Advanced Settings section of the Setup page to access the Setup Advanced Settings - DMZ Host page.

Setup Advanced Settings - DMZ Host Page Example

The following illustration is an example of the Setup Advanced Settings - DMZ Host page.

System Signal Status Log EMTA Setup

Setup
Advanced Settings - DMZ Host
The LAN IP address listed as the DMZ Host will have traffic forwarded to it from the public Internet. The DMZ Host is exposed to the public Internet and not protected by filtering.

DMZ Address 192.168.0.

Apply

Setup Advanced Settings - DMZ Host Page Description

Use this page to place a Private LAN IP device, for example, an FTP, Mail, or Web server directly on the Internet (bypassing the firewall). You set the server with a fixed IP address as a DMZ Host by entering its IP address in the DMZ Address field. Make sure the IP address used is not in the range of addresses delivered by the built-in DHCP server. After setting up a DMZ Host, all ports on this device are open to the Internet. You may configure only one PC to be the DMZ host. DMZ is generally used for PCs running “problem” applications that use random port numbers and do not function correctly with the specific port triggers or port forwarding setups described earlier in this guide. After entering a DMZ Address, click **Apply** to apply and save your new DMZ Host setting.

Configuring Firewall Protection

Use the Setup Firewall - Options page to configure Web page filtering and firewall protection. This page allows you to enable various firewall protection filters.

Note: If you are not familiar with the advanced settings detailed in this section, contact your cable service provider before you attempt to change any of the wireless home gateway default firewall options settings.

Click **Options** in the Firewall section of the Setup page to access the Setup Firewall - Options page.

Setup Firewall - Options Page Example

The following illustration is an example of the Setup Firewall - Options page.

Setup
Firewall - Options
This page allows you to configure web page filtering and firewall protection.

Filter Proxy	<input type="checkbox"/> Enable
Filter Cookies	<input type="checkbox"/> Enable
Filter Java Applets	<input type="checkbox"/> Enable
Filter ActiveX	<input type="checkbox"/> Enable
Filter Popup Windows	<input type="checkbox"/> Enable
Block Fragmented IP Packets	<input checked="" type="checkbox"/> Enable
Port Scan Detection	<input type="checkbox"/> Enable
IP Flood Detection	<input checked="" type="checkbox"/> Enable
Firewall Protection	<input checked="" type="checkbox"/> Enable

Apply

Setup Firewall - Options Page Description

This section describes the section headings and fields descriptions of the Setup Firewall - Options page.

Note: If you make changes in any of the fields in the Setup Firewall - Options page, click **Apply** to apply and save your Firewall settings.

The following table provides a description of each field name within the Setup Firewall - Options page.

Field Name	Description
Filter Proxy	Enables/ disables proxy
Filter Cookies	Enables/ disables cookie blocking. This feature filters the unsolicited delivery of cookies to devices from the Internet to devices in your private local network. Cookies are computer files that contain personal information or Web surfing behavior data.
Filter Java Applets	Enables/ disables java applets. This feature helps to protect the devices in your private network from irritating or malicious Java applets that are sent, unsolicited, to devices in your private network from the Internet. These applets run automatically when they are received by a PC.
Filter ActiveX	Enables/ disables ActiveX controls. This feature helps to protect the devices in your private network from irritating or malicious ActiveX controls that are sent, unsolicited, to devices in your private network from the Internet. These ActiveX controls run automatically when they are received by a PC.
Filter Popup Windows	Enables/ disables popup windows. Some commonly used applications employ popup windows as part of the application. If you disable popup windows, it may interfere with some of these applications.
Block Fragmented IP Packets	Enables/ disables filtering of fragmented IP packets. This feature helps protect your private local network from Internet based denial of service attacks.
Port Scan Detection	Enables/ disables the gateway from responding to Internet based port scans. This feature is designed to protect your private local network from Internet based hackers who attempt to gain unsolicited access your network by detecting open IP ports on your gateway.

Field Name	Description
IP Flood Detection	Blocks malicious devices that are attempting to flood devices or networks with illegal broadcast packets. Also referred to as "broadcast storm."
Firewall Protection	Enables/disables the firewall. When the firewall is enabled, the firewall will allow most commonly used applications to automatically open IP ports and pass data without any special setup or manual port configuration.

Configuring Firewall Event Logging and E-mail Alerts

Use the Setup Firewall - Event Logging page to access the firewall event log and allows you to enter your e-mail address in order for you to receive e-mail alerts related to firewall attacks by hackers.

Note: If you are not familiar with the settings detailed in this section, contact your cable service provider before you attempt to change any of the wireless home gateway default firewall event logging settings.

Click **Event Logging** in the Firewall section of the Setup page to access the Setup Firewall - Event Logging page.

Setup Firewall - Event Logging Page Example

The following illustration is an example of the Setup Firewall - Event Logging page.

Setup
Firewall - Event Logging
This page provides access to the firewall event log and allows you to enter your email address for email alerts related to firewall attacks.

Contact Email Address
SMTP Server Name
E-mail Alerts *Enable*

Description	Count	Last Occurrence	Target	Source
-------------	-------	-----------------	--------	--------

Setup Firewall - Event Logging Page Description

The Setup Firewall - Event Logging page shows events captured by the firewall. The log displays the following items:

- Description of the event
- Number of events that have occurred
- Last occurrence of an event
- Target and source addresses

You can configure the system to e-mail log events to the administrator in order for the administrator to monitor the firewall.

This section describes the section headings and fields descriptions of the Setup Firewall - Event Logging page.

How Do I Configure the Wireless Home Gateway?

Field Name	Description
Enable Email Address	Allows you to enter the e-mail address of the person who monitors the firewall. When an event occurs, it will be logged and an email will be sent to this address automatically reporting the event.
SMTP Server Name	Allows you to enter the mail server name of your outgoing mail server, or the mail server of your Internet service provider (ISP)
E-mail Alerts	Allows you to enable or disable sending e-mail alerts
Description	Describes what event was detected by the gateway's firewall
Count	Displays the number of times the event has been detected
Last Occurrence	Displays the time the last occurrence of this event was detected
Target	Displays the IP address of the device in your private local network to which the event was directed along with the IP port number targeted by the event
Source	Displays the IP address of the Internet based source of the event along with the IP port number used by that device

Function Keys

The following function keys appear on the Setup Firewall - Event Logging page.

Key	Description
Apply	Saves the values you enter into the fields without closing the screen
E-mail Log	Allows you to force the system to send an e-mail alert even if the E-mail Alerts box is left unchecked
Clear Log	Allows you to clear all entries in the log

Configuring Parental Control

Use the Setup Parental Control - User Setup page to configure parental controls on the wireless home gateway, and to add or delete the individuals who are authorized to set parental controls.

Note: If you are not familiar with the settings detailed in this section, contact your cable service provider before you attempt to change any of the wireless home gateway default parental control settings.

Click **User Setup** in the Parental Control section of the Setup page to access the Setup Parental Control - User Setup page.

Setup Parental Control - User Setup Page Example

The following illustration is an example of the Setup Parental Control - User Setup page.

Setup
Parental Control - User Setup
 This page allows configuration of users.

User Configuration	
<input type="text"/>	<input type="button" value="Add User"/>
User Settings	
1. Default	<input type="checkbox"/> Enable <input type="button" value="Remove User"/>
Password	<input type="text"/>
Re-Enter Password	<input type="text"/>
Trusted User	<input checked="" type="checkbox"/> Enable
Content Rule	1. Default
Time Access Rule	No rule set.
Session Duration	0 min
Inactivity time	0 min
<input type="button" value="Apply"/>	

Setup Parental Control - User Setup Page Description

This section describes the section headings and fields descriptions of the Setup Parental Control - User Setup page. This page allows you to set up user profiles. Each profile can be assigned customized levels of Internet access as defined by the access rules assigned to that user's profile.

Note: Once you define and enable user profiles, each user must sign-on each time they wish to access the Internet. The user can sign-on when the pop-up sign-on screen appears in their Web browser. The user must enter their correct user name and password in order to gain Internet access.

How Do I Configure the Wireless Home Gateway?

Important!

- Make sure to disable pop-up blockers on your Web browser when using user profiles.
- User names and passwords are case-sensitive.

Field Name	Description
Add User	Allows you to add a new user profile. Enter the name of the user and click the Add User button to add the user to the list.
User Settings	<p>Allows you to edit a user profile by using the drop-down menu to edit a user profile. The drop-down menu allows you to recall the profile to be edited. User names and passwords are case-sensitive.</p> <p>Make sure to check the Enable box to activate the user profile. If a profile is not active, that user will not have any access to the Internet.</p> <p>To remove a user profile, use the drop-down menu to select the user to be removed and click the Remove User button.</p>
Password	<p>Enter the selected user's password in this field. Each user must enter their User Name and Password each time they use the Internet. User names and passwords are case-sensitive.</p> <p>Note: The Gateway will allow each user access to the Internet, subject to the rules selected on this page for that user.</p>
Re-Enter Password	Re-enter the same password for confirmation of the password in the previous field.
Trusted User	Check this box if the currently selected user is to be designated a trusted user. Trusted users are not subject to Internet access rules.
Content Rule	Select the Content Rule for the current user profile. Content Rules must first be defined by going to the Rules Configuration page. You can access the Rule Configuration page by clicking on the "Basic Rules" link under the Parental Control section of the Setup page.
Time Access Rule	Select the Time Access Rule for the current user profile. Time Access Rules must first be defined by going to the Time of Day Filter page. You can access the Time of Day Filter page by clicking on the " <u>Time of Day Rules</u> " link under the Parental Control section of the Setup page.

How Do I Configure the Wireless Home Gateway?

Field Name	Description
Session Duration	1440 minutes (factory default). Enter the amount of time in minutes that the user will be granted Internet access beginning at the time they sign on using their User Name and Password. Note: Set the Session Duration to 0 (zero) to prevent session timeout.
Inactivity time	60 minutes (factory default). Enter the amount of time during a user session where there is no Internet access activity, indicating that the user is no longer online. If the inactivity timer is triggered, the user session will be closed automatically. In order to regain Internet access, the user must log in again with their User Name and Password. Note: Set the Inactivity time value to 0 (zero) to prevent timeout due to inactivity.
Available Rules	Lists available rules. Apply a rule by selecting it from the list and adding it to the current user profile. Note: Create rules using the Parental Control Setup pages that follow next.
Current Used Rules	Lists rules in use for the current user profile. You can apply a maximum of four rules to each user profile.

Function Keys

The following function keys appear on the Setup Parental Control - User Setup page.

Key	Description
Add User	Adds and saves a new user to the list of user profiles
Remove User	Removes the selected user from the list of user profiles
Apply	Saves all additions, edits, and changes

Configuring Parental Controls Basic Rules

Use the Setup Parental Control - Basic Setup page to select the rules that block certain Internet content and certain Web sites.

Note: If you are not familiar with the settings detailed in this section, contact your cable service provider before you attempt to change any of the wireless home gateway default parental control settings.

Click **Basic Rules** in the Parental Control section of the Setup page to access the Setup Parental Control - Basic Setup page.

Setup Parental Control - Basic Setup Page Example

The following illustration is an example of the Setup Parental Control - Basic Setup page.

Setup
Parental Control - Basic Setup
This page allows basic selection of rules which block certain Internet content and certain Web sites. When you change your Parental Control settings, you must click on the appropriate "Apply", "Add" or "Remove" button for your new settings to take effect. If you refresh your browser's display, you will see the currently active settings.

Parental Control Activation
This box must be checked to turn on Parental Control
 Enable Parental Control

Rule Configuration

Rule Settings
1. Default

Keyword List	Blocked Domain List	Allowed Domain List
<input type="text" value="anonymizer"/>	<input type="text" value="anonymizer.com"/>	<input type="text"/>
<input type="text"/> <input type="button" value="Add Keyword"/>	<input type="text"/> <input type="button" value="Add Domain"/>	<input type="text"/> <input type="button" value="Add Allowed Domain"/>
<input type="button" value="Remove Keyword"/>	<input type="button" value="Remove Domain"/>	<input type="button" value="Remove Allowed Domain"/>

Override Password
If you encounter a blocked website, you can override the block by entering the following password

Password	<input type="password" value="••••••"/>
Re-Enter Password	<input type="password" value="••••••"/>
Access Duration	<input type="text" value="30"/>
<input type="button" value="Apply"/>	

Setup Parental Control - Basic Setup Page Description

This section describes the section headings and fields descriptions of the Setup Parental Control - Basic Setup page. This page allows you to create Internet access rules based on the content found in the URLs of Internet sites.

Field Name	Description
Rule Configuration	<p>Allows you to add a new content rule. Enter the name of the rule and click the Add Rule button to add the content rule to the list. Content rules are used to restrict Internet access based on IP addresses, domains, and keywords found in the URLs of Internet sites.</p> <p>Note: It may be useful to set up your first rule as “No Rule,” without any restrictions or settings. This setting will allow you to assign “No Rule” status to users who are not subject to “content-related” access restrictions.</p>
Rule Settings	<p>Allows you to edit a content rule by using the drop-down menu to recall the rule to be edited.</p> <p>To remove a user profile, use the drop-down menu to select the rule to be removed and click on the Remove Rule button.</p>
Keyword List	Allows you to create a list of keywords. Any attempt to access a URL that contains any of the keywords in this list will be blocked by the gateway.
Blocked Domain List	Allows you to create a list of Domains that the gateway should block access to. Any attempt to access any of the Domains in this list will be blocked by the gateway.
Allowed Domain List	Allows you to create a list of Domains to which the gateway allows access.
Override Password	Allows you to create a password to temporarily override user access restrictions to a blocked Internet site.
Re-enter Password	Re-enter the same password for confirmation of the override password in the previous field.
Duration	Allows you to designate an amount of time in minutes that the Override password will allow temporary access to a restricted Internet site.

How Do I Configure the Wireless Home Gateway?

Function Keys

The following function keys appear on the Setup Parental Control - Basic Setup page.

Key	Description
Add Rule	Adds and saves a new Rule to the list of content Rules
Remove Rule	Removes the selected rule from the content rule list
Add/Remove Keyword	Allows you to add new keywords to the list or to delete selected keywords from the list
Add/Remove Domain	Allows you to add new domains to the list or to delete selected domains from the list
Add/Remove Allowed Domain	Allows you to add new domains to the list or to delete selected domains from the list
Apply	Saves all additions, edits, and changes

To use keyword and domain blocking

Keyword and Domain blocking allows you to restrict access to Internet sites by blocking access to those sites based on a word or a text string contained in the URLs used to access those Internet sites.

Domain blocking allows you to restrict access to Web sites based on the site's Domain Name. The Domain Name is the portion of the URL that precedes the familiar .COM, .ORG, or .GOV extension.

Keyword blocking allows you to block access to Internet sites based on a Keyword or text string being present anywhere in the URL, not just in the Domain Name.

Note: The Domain blocking feature blocks access to any Domain in the Domain List. It will also block Domains, any portion of which contains an exact match to entries in the list.

For example, if you enter **example.com** as a Domain, any site that contains "example.com" will be blocked. Generally, you do not want to include "www." in a Domain Name since doing so limits the blocking to only the site that matches that Domain Name exactly. For instance, if you enter **www.example.com** into the list, only the one site that matches that name exactly will be blocked. Consequently, if you do not include the "www.," then all sites within and associated with "example.com" will be blocked.

Configuring Parental Control Advanced Settings

Use the Setup Parental Control - Advanced Settings page to configure parental control rules that apply to the home network.

Note: If you are not familiar with the settings detailed in this section, contact your cable service provider before you attempt to change any of the wireless home gateway default parental control settings.

Click **Advanced Rules** in the Parental Control section of the Setup page to access the Setup Parental Control - Advanced Settings page.

Setup Parental Control - Advanced Settings Page Example

The following illustration is an example of the Setup Parental Control - Advanced Settings page.

System Signal Status Log EMTA Setup

Setup
Parental Control - Advanced Settings
This page allows configuration of parental control rules that apply to the home network.

[Click here to subscribe to Parental Control Service](#)

Ratings Service	
Subscription Status :	Not Subscribed
Expiration Date :	Thu Jan 01 00:00:08 1970
Service State :	N/A

Rule Settings (A policy must first be created [here](#) in order to apply the category rules)

Setup Parental Control - Advanced Settings Page Description

This section describes the section headings and fields descriptions of the Setup Parental Control - Advanced Settings page.

Note: A subscription is required. You must subscribe to the Parental Control Service by clicking on the link displayed on the Setup Parental Control Advanced Settings page.

Field Name	Description
Ratings Service	<p>Your Internet Service provider may offer advanced parental control services. Advanced parental control utilizes Internet based servers to rate Web sites for undesirable content. The rating service will evaluate and rate every Internet site that a user attempts to access through your gateway. The process is extremely fast and does not affect the time it takes to bring up Internet sites on your browser.</p> <p>If a category (or categories) is selected from the rating service category list, then access to any Internet site that has a rating that matches the selected category will be blocked by the gateway.</p>
Subscription Status	<p>Displays the following information regarding your subscription status:</p> <ul style="list-style-type: none"> ■ Active - Subscription to a rating service is active. ■ Inactive (factory default) - No rating service available.
Expiration Date	Displays the date the Parental Control Service subscription expires.
Service State	Displays the type of subscription service to which you are subscribed.
Rules Settings	<p>Allows you to attach the selected rating service categories to a previously defined parental control access rule.</p> <p>Use the Rule Setting drop down menu to select the rule to which you want to apply the current set of selected categories.</p>

Configuring Parental Control Time of Day Access Filters

Use the Setup Parental Control - Time of Day Access Filter page to configure Web access filters to block all Internet traffic to and from specific network devices based on day of week and time of day settings that you select.

Note: If you are not familiar with the settings detailed in this section, contact your cable service provider before you attempt to change any of the wireless home gateway default parental control settings.

Click **Time of Day Rules** in the Parental Control section of the Setup page to access the Parental Control - Time of Day Access Filter page.

Setup Parental Control - Time of Day Access Filter Page Example

The following illustration is an example of the Setup Parental Control - Time of Day Access Filter page.

Note: The wireless home gateway uses the network time of day clock that is managed by your data service provider. The time of day clock must be accurate and represent the time of day in your time zone for this feature to operate properly. Verify that the Status and Set Time pages reflect the correct time of day. If they do not reflect the correct time of day, contact your data service provider. You can also adjust your settings to account for the difference.

System Signal Status Log EMTA Setup

Setup

Parental Control - Time of Day Access Filter

This page allows configuration of web access filters to block all internet traffic to and from specific network devices based on time of day settings.

Add

No filters entered. Enabled Remove

Days to Block

Everyday Sunday Monday Tuesday
 Wednesday Thursday Friday Saturday

Time to Block

All day

Start: (hour) (min)

End: (hour) (min)

Apply

Function Keys

The following function keys appear on the Setup Parental Control - Time of Day Access Filter page.

Key	Description
Add	Allows you to add a new Time of Day access filter or rule. Enter the name of the filter and click the Add key to add the filter to the list. Time of Day rules are used to restrict Internet access based on the day and time.
Remove	Removes the selected filter from the Time of Day filter list.
Apply	Saves all additions, edits, and changes.

Configure Parental Control Event Reporting

Use the Setup Parental Control - Event Log page to view events captured by the parental control event-reporting feature.

Note: If you are not familiar with the settings detailed in this section, contact your cable service provider before you attempt to change any of the wireless home gateway default parental control settings.

Click **Local Log** in the Parental Control section of the Setup page to access the Setup Parental Control - Event Log page.

Setup Parental Control - Event Log Page Example

The following illustration is an example of the Setup Parental Control - Event Log page.

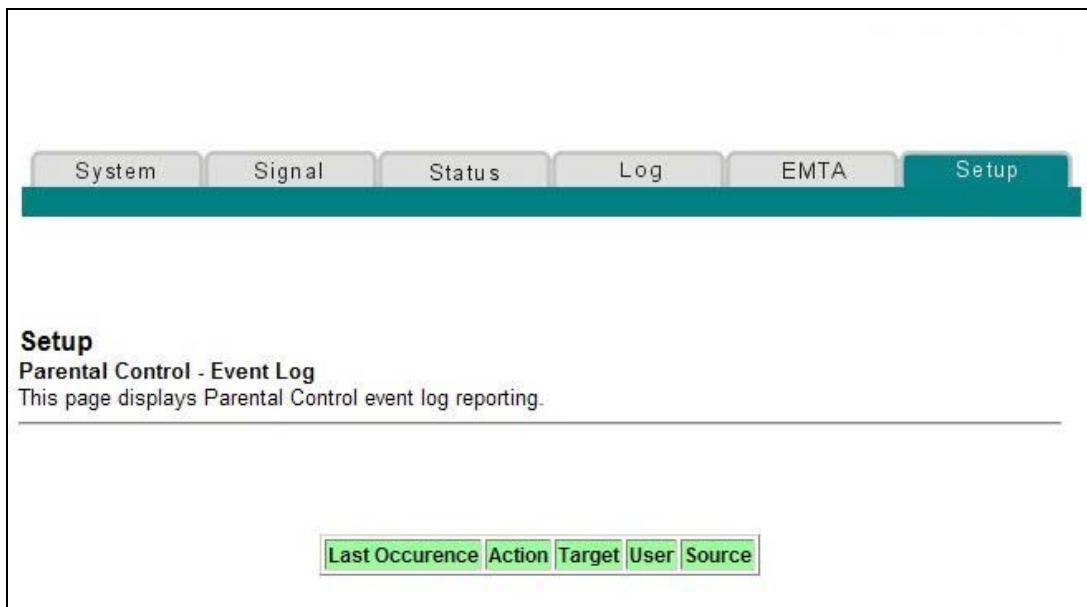

Setup Parental Control - Event Log Page Description

This section describes the section headings and fields descriptions of the Setup Parental Control - Event Log page. This page allows you to track, by user, any attempts made by that user to access Internet sites that are restricted.

Field Name	Description
Last Occurrence	Displays the time of the most recent attempt to access a restricted Internet site
Target	Displays the URL of the restricted site
User	Displays the user who attempted a restricted site
Source	Displays the IP address of the PC which was used when attempting to access a restricted Web site

Configuring Virus Protection

Use the Setup Virus Protection - Antivirus Setup page to access a Web site that allows you to download a free evaluation copy of antivirus software.

Important! The antivirus software must be installed on all PCs or computers that are connected to the wireless home gateway.

Note: If you are not familiar with the settings detailed in this section, contact your cable service provider before you attempt to change any of the wireless home gateway default antivirus settings.

Click **Antivirus Setup** in the Virus Protection section of the Setup page to access the Setup Virus Protection - Antivirus Setup page.

Setup Virus Protection - Antivirus Setup Page Example

The following illustration is an example of the Setup Virus Protection - Antivirus Setup page.

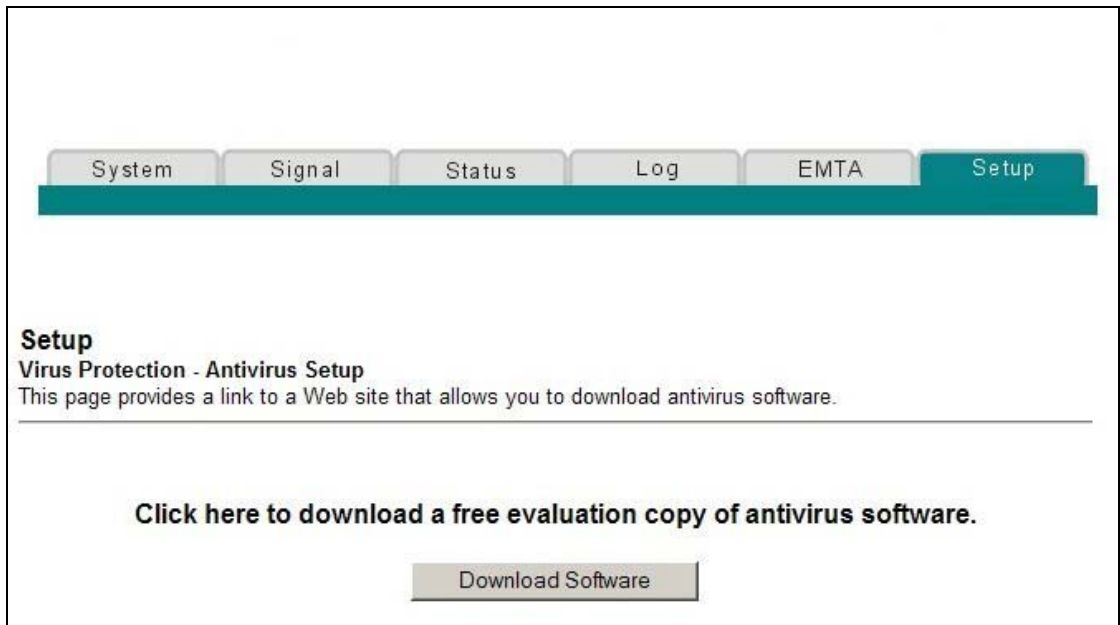

Function Key

The following function key appears on the Setup Virus Protection - Antivirus Setup page.

Key	Description
Download Software	Click to download a free evaluation copy of antivirus software.

How Do I Configure the Wireless Home Gateway?

Configuring Your Wireless Access Point Parameters

Use the Setup Wireless - Basic page to configure your wireless access point (WAP) parameters, included SSID and channel number.

Note: If you are not familiar with the advanced settings detailed in this section, contact your cable service provider before you attempt to change any of the wireless home gateway default wireless basic settings.

Click **Basic** in the Wireless section of the Setup page to access the Setup Wireless - Basic page.

Setup Wireless - Basic Page Example

The following illustration is an example of the Setup Wireless - Basic page showing the factory default settings.

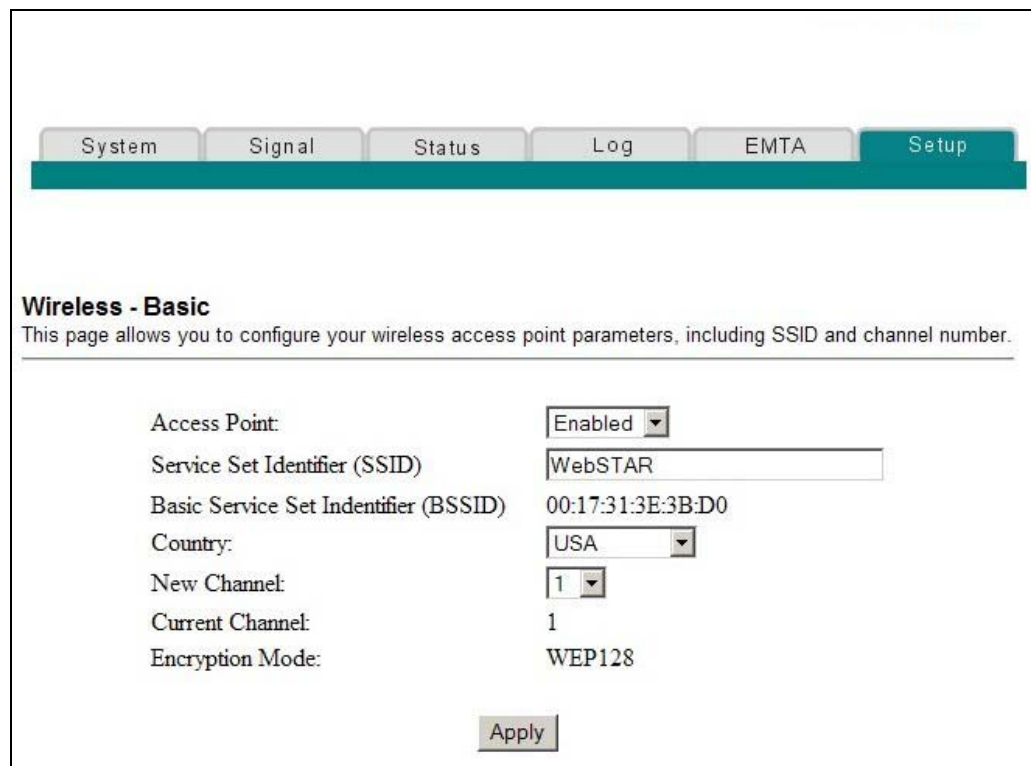

The screenshot shows a web interface with a navigation bar at the top containing tabs for System, Signal, Status, Log, EMTA, and Setup. The Setup tab is active. Below the navigation bar, the page title is "Wireless - Basic" with a subtitle: "This page allows you to configure your wireless access point parameters, including SSID and channel number." The configuration fields are as follows:

Access Point:	Enabled
Service Set Identifier (SSID)	WebSTAR
Basic Service Set Identifier (BSSID)	00:17:31:3E:3B:D0
Country:	USA
New Channel:	1
Current Channel:	1
Encryption Mode:	WEP128

An "Apply" button is located at the bottom of the configuration area.

Setup Wireless - Basic Page Description

This section describes the section headings and fields descriptions of the Setup Wireless - Basic page.

Note: If you make changes in the Setup Wireless - Basic page, click **Apply** to apply and save your wireless basic settings.

Field Name	Description
Access Point	Allows you to turn the access point on the gateway on or off
Service Set Identifier (SSID)	The name assigned to this access point Note: The factory default for the SSID field should contain the product name WebSTAR .
Basic Service Set Identifier (BSSID)	The MAC address of the access point
Country	Allows you to select the country in which you are using your access point
New Channel (1-11)	Allows setting a communications channel for your access point Note: Wireless networking channels overlap. Channels 1, 6, and 11 do not overlap with each other. For best performance, select one of these channels. If there are other access points in use in the area, select one of these channels that is farthest away from the other access points. Example: If channel 8 is in use by another access point, use channel 1 for your wireless network. Note: If your wireless network is not operating correctly, or if external devices are interfering with your signal, select a different channel. Use your PC wireless utility software to scan for other access points in your area.
Current Channel	Present channel the WAP is using
Encryption Mode	Shows current encryption mode

Configuring Your Wireless Network Security and Encryption Parameters

Use the Setup Wireless - Security page to configure your WAP wireless equivalent privacy (WEP) encryption keys and authentication.

Note: If you are not familiar with the advanced settings detailed in this section, contact your cable service provider before you attempt to change any of the wireless home gateway default wireless security settings.

Click **Security** in the Wireless section of the Setup page to access the Setup Wireless - Security page.

Important! Your wireless home gateway ships from the factory with 128-bit WEP encryption enabled to provide you with a *basic* level of wireless network security. To gain initial access to your wireless network, select 128-bit WEP encryption on your computer's wireless adapter and enter the 128-bit encryption key to match the key setup in your gateway. The factory default 128-bit key in the gateway is 26 zeros (see the following example). You can continue to use this factory default key. However, to maximize your wireless security, it is highly recommended that you use something other than the factory default key.

Setup Wireless - Security Page Example

The following illustration is an example of the Setup Wireless - Security page.

Wireless - Security
This page allows you to configure your wireless access point WEP encryption keys and authentication.

Network Authentication

WPA Encryption

WPA Pre-Shared Key

RADIUS Server

RADIUS Port

RADIUS Key

WPA Group Rekey Interval seconds

Data Encryption

Shared Key Authentication

PassPhrase

64 bits Key 1

64 bits Key 2

64 bits Key 3

64 bits Key 4

128 bits Key 1

128 bits Key 2

128 bits Key 3

128 bits Key 4

Current Network Key

Setup Wireless - Security Page Description

This section describes the section headings and fields descriptions of the Setup Wireless - Security page.

Note: If you make changes in the Setup Wireless - Security page, click Apply to apply and save your wireless security settings.

How Do I Configure the Wireless Home Gateway?

Field Name	Description
Network Authentication	<p>Network Authentication allows only authorized users to gain access to your wireless network. Only users with an authorized user name, password, or pre-shared key are allowed access to the wireless network.</p> <p>Select from the following Network Authentication protocols:</p> <ul style="list-style-type: none"> ■ Disabled (factory default) ■ 802.1x ■ WPA ■ WPA-PSK <p>Note: Network Authentication restricts access to your wireless network to only authorized computers or users. Authentication does not protect the data you send over the wireless network connection. You must enable encryption to protect data that is transmitted over your wireless network.</p>
WPA Pre-Shared Key	<p>Allows you to set a WPA Pre-Shared encryption key. Enter a text string in this field. The text string or phrase is used to generate a unique set of encryption keys for your network. Use this string to set up wireless devices in your network.</p> <ul style="list-style-type: none"> ■ The PSK can be either a text string or a 64 character hexadecimal number. ■ The text string must be an ASCII character string with a minimum of 8 characters but no more than 63. <p>Note: Not all wireless adapter devices support PSK. For these devices, you must enter the encryption keys exactly as they appear in the in wireless gateway fields in the preceding illustration of the Setup Wireless Security page.</p>
WPA Group Rekey Interval	<p>Allows you to set the WPA Group Rekey Interval in seconds. This only applies when WPA and WPA-PSK Network Authentication is enabled.</p> <p>Set this value to 0 (factory default) to disable periodic rekeying. The valid range is 1 to 4,294,967,295 seconds.</p>

How Do I Configure the Wireless Home Gateway?

Field Name	Description
RADIUS Server	<p>Allows you to enter the IP address of the RADIUS server used for authentication and encryption key derivation.</p> <ul style="list-style-type: none"> ■ This field is used with 802.1x and WPA Network Authentication. ■ The factory default for this field is 0.0.0.0.
RADIUS Port	<p>Determines the port number of the RADIUS server. The port number is usually 1812 (factory default) or 1645, depending on the server used.</p> <p>This field is used with 802.1x and WPA Network Authentication.</p>
RADIUS Key	<p>Allows you to set the Shared Secret key for your RADIUS connection.</p> <ul style="list-style-type: none"> ■ The factory default for this field is empty. ■ This field is used with 802.1x and WPA Network Authentication.
Data Encryption	<p>Allows you to enable data encryption to help secure the data that is sent over your wireless network.</p> <ul style="list-style-type: none"> ■ WEP 128-bit (factory default) <ul style="list-style-type: none"> – 128-bit or-64 bit static key data encryption can be selected when the network is configured to have no authentication. – 128-bit static key data encryption is automatically selected when 802.1x network authentication is enabled. <p>Note: Static key authentication uses one of the four encryption keys, as define below, to encrypt your data. You must manually change keys. The keys do not change or rotate automatically as they do with TKIP.</p> <ul style="list-style-type: none"> ■ TKIP (Temporal Key Integrity Protocol) data encryption is automatically enabled when WPA and WPA-PSK network authentication is enabled. <p>Notes:</p> <ul style="list-style-type: none"> ■ 64-bit and 40-bit encryption are two different names for the same encryption ■ 128-bit and 104-bit encryption are two different names for the same encryption

How Do I Configure the Wireless Home Gateway?

Field Name	Description
Shared Key Authentication	<p>Allows you to determine if Shared Key Authentication is used in the network. Shared Key Authentication can be used when there is no other network authentication in the network.</p> <ul style="list-style-type: none"> ■ Optional - (factory default) Wireless clients can associate with the wireless access point without authentication. ■ Required - Only wireless clients with a valid network key are allowed to associate with the access point.
PassPhrase	<p>Automatically generates WEP encryption keys required to communicate with the network.</p> <p>Although not required for WEP operation, use of a PassPhrase can simplify the configuration and setup of each of your client wireless adapters.</p> <p>Using a PassPhrase eliminates the need to manually enter lengthy encryption keys and reduces the chance of error associated with entering entry of large numbers.</p>
64 Bit Keys 1 through 4	<p>Select these keys for use with Encryption Mode set to 64-bit encryption. Enter 5-byte values for a Key. You do not have to set all four Keys. Only one Key is used for a home network. Each value is represented in hexadecimal. Use only these numbers or letters: 0, 1, 2, 3, 4, 5, 6, 7, 8, 9, a, b, c, d, e, and f to set up your encryption keys.</p> <p>Note: It is generally a good practice to use only lowercase letters when entering WEP encryption keys. Uppercase letters can sometimes be confused with numbers. For example, the uppercase letter "B" is often mistaken for the number "8." Using lowercase characters minimizes the risk of confusing characters when copying keys from one device to another. Uppercase characters will automatically be converted to lowercase when the key or keys are applied and saved to memory.</p> <p>Use two numbers or letters in each box. Record your Key values. You will need these Key values when you set up your client wireless adapter. The Key values in each wireless network device must match.</p>

How Do I Configure the Wireless Home Gateway?

Field Name	Description
<p>128 Bit Keys 1 through 4</p>	<p>Select these keys for use with Encryption Mode set to 128-bit encryption. Enter 13-byte values for a Key. You do not have to set all four Keys. Usually only one is needed for a home network. Each value is represented in hexadecimal. Use only these numbers or letters: 0, 1, 2, 3, 4, 5, 6, 7, 8, 9, a, b, c, d, e, and f to set up your encryption keys.</p> <p>Note: The Factory Default setting is 26 ones: 11111111111111111111111111111111</p> <p>It is generally a good practice to use only lowercase letters when entering WEP encryption keys. Uppercase letters can sometimes be confused with numbers. For example, the uppercase letter "B" is often mistaken for the number "8." Using lowercase characters minimizes the risk of confusing characters when copying keys from one device to another. Uppercase characters will automatically be converted to lowercase when the key or keys are applied and saved to memory.</p> <p>Use two numbers or letters in each box. Record your Key values. You will need these Key values when you set up your client wireless adapter. The Key values in each wireless network device <i>must</i> match.</p>
<p>Current Network Key</p>	<p>Allows you to select which of the four 64-bit or 128-bit keys to use to encrypt your data when you are using encryption that requires the manual entry of an encryption key. Only one WEP key is in use at a time. You must manually change keys. They do not change automatically.</p> <p>Notes:</p> <ul style="list-style-type: none"> ■ 64-bit and 40-bit encryption are two different names for the same encryption ■ 128-bit and 104-bit encryption are two different names for the same encryption

How Do I Configure the Wireless Home Gateway?

Function Keys

Key	Description
Generate WEP Keys	Automatically generates four WEP keys based on the PassPhrase entry. Notes: <ul style="list-style-type: none">■ For 64-bit WEP, four unique 64-bit WEP keys will be generated■ For 128-bit WEP, only one 128-bit WEP key will be generated. The same key will be entered into all four key locations.
Apply	Saves all additions, edits, and changes

Configuring Wireless Data Rates and WiFi Thresholds

Use the Setup Wireless - Advanced page to configure your WAP data rates and wireless fidelity (WiFi) thresholds.

Note: If you are not familiar with the advanced settings detailed in this section, contact your cable service provider before you attempt to change any of the wireless home gateway default wireless advanced settings.

Click **Advanced** in the Wireless section of the Setup page to access the Setup Wireless - Advanced page.

Setup Wireless - Advanced Page Example

The following illustration is an example of the Setup Wireless - Advanced page.

Note: We recommend that you do not change the default wireless settings that are shown in the preceding illustration unless you are instructed to do so by your cable service provider.

Wireless - Advanced
This page allows you to configure your wireless access point data rates and WIFI thresholds.

54g?Network Mode	<input type="text" value="Max Compatibility"/>
54g?Protection	<input type="text" value="Auto"/>
Rate	<input type="text" value="Auto"/>
Output Power	<input type="text" value="100%"/>
Beacon Interval	<input type="text" value="100"/> ms (0-65535)
DTIM Interval	<input type="text" value="1"/> ms (1-255)
Fragmentation Threshold	<input type="text" value="2346"/> bytes (256-2346)
RTS Threshold	<input type="text" value="2347"/> (0-2347)

To reflect configurations changed, you must reboot system!

Setup Wireless - Advanced Page Description

This section describes the section headings and fields descriptions of the Setup Wireless - Advanced page.

Note: If you make changes in the Setup Wireless - Advanced page, click Apply to apply and save your wireless advanced settings.

How Do I Configure the Wireless Home Gateway?

Field Name	Description
54g Network Mode	<p>Allows you to optimize the performance of your wireless network using one of the following options:</p> <ul style="list-style-type: none"> ■ Max compatibility (factory default) Allows the access point to interoperate with both 802.11b and 802.11g wireless client devices and minimizes interference with nearby 802.11b wireless networks. ■ 54g Only The wireless access point will only accept 802.11g wireless clients. ■ Max Performance Maximum throughput. In this mode, the wireless access point accepts only 802.11g wireless clients. Setting the device in this mode may degrade the operation of near by 802.11b wireless networks.
54g Protection	<p>Allows you to prioritize 802.11g communication when there is a mix of 802.11b and 802.11g devices in the wireless network using one of the following options:</p> <ul style="list-style-type: none"> ■ Auto (factory default) Maximize 802.11g performance in networks with a mix of 802.11b and 802.11g wireless client devices. ■ Off Maximum performance. Networks with 802.11g-only wireless client devices.
Rate	<p>Allows you to fix the data rate for wireless connections. The following data rates are available:</p> <p>Auto (factory default), 1 Mbps, 2 Mbps, 5.5 Mbps, 6 Mbps, 9 Mbps, 11 Mbps, 12 Mbps, 18 Mbps, 24 Mbps, 36 Mbps, 48 Mbps, 54 Mbps</p> <p>Note: In the automatic mode, data rate is a function of signal strength and signal quality.</p>
Output Power	<p>Allows you to adjust the relative output power of your gateway wireless transmitter. The following settings are available:</p> <p>100% (factory default), 75%, 50%, and 25%</p>

How Do I Configure the Wireless Home Gateway?

Field Name	Description
Beacon Interval	Displays the time interval that the WAP uses to announce itself to remote devices. The Beacon Interval should be left at 100ms for compliance with most client cards. The Beacon Interval specifies how often packets are sent by the Access Point (AP) to synchronize a wireless network and its clients
DTIM Interval	Displays the time interval between Broadcasts/Multicast transmissions. The DTIM (Delivery Traffic Indication Message) Interval is a countdown informing the wireless clients of the next window for listening to broadcast and multicast messages. When the AP has buffered broadcast or multicast messages for associated clients, it sends the next DTIM with a DTIM Interval value. AP clients hear the beacons and awaken to receive the broadcast and multicast messages. The DTIM Interval should be left at 3 ms for compliance with most client cards
Fragmentation Threshold	Allows you to set the fragmentation threshold. This threshold should be set equivalent to the maximum Ethernet frame size allowable on the link including overhead (1536 bytes). Lesser settings can damage data throughput as large frames could be fragmented or collisions could occur. The factory default is 2346
RTS Threshold	Determines at what packet size beyond which the ready to send/clear to send (RTS/CTS) mechanism is invoked. The factory default is 2347

Configuring Wireless Access Point Access Control

Use the Setup Wireless - Access Control page to configure your wireless access point access control.

Note: If you are not familiar with the advanced settings detailed in this section, contact your cable service provider before you attempt to change any of the wireless home gateway default wireless advanced settings.

Click **Access Control** in the Wireless section of the Setup page to access the Setup Wireless - Access Control page.

Setup Wireless Access Control Page Example

Setup Wireless - Access Control Page Description

This section describes the section headings and field descriptions of the Setup Wireless - Access Control page.

Field Name	Description
Access restriction	<p>When encryption is enabled, this selection allows you to choose one of the following options from the drop-down list:</p> <ul style="list-style-type: none"> ■ Disable (factory default)-No access restrictions based on MAC address of wireless access devices ■ Allow-Allows wireless access to only the MAC addresses listed in the Access List ■ Deny-Denies wireless access to only the MAC address listed in the Access List

How Do I Configure the Wireless Home Gateway?

Field Name	Description
Closed Network	Allows you to disable or enable the network to access by wireless clients. When ON is selected, the access point does not broadcast the SSID. The client device must be configured manually with the SSID and the MAC address of the access point in order to access with wireless network.
Access List	Displays the MAC address of the clients that are subject to wireless access control
Connected Clients	Displays the Host Name, IP Address, and Client ID of wireless clients that are connected to (associated with) the gateway modem

Function Keys

The following function keys appear on the Setup Firewall - Event Logging page.

Key	Description
Apply	Applies and saves the values you enter into the fields without closing the screen
Clear All	Clears the Access List
Remove	Removes entries from the Access List
Add	Adds a client to the Access List using the MAC address of the client

Telephone Service Frequently Asked Questions

This section provides answers to frequently asked questions regarding wireless home gateway telephone service. For issues regarding wireless home gateway Internet service, see *How Do I Troubleshoot My Internet Service Installation?* (on page 35)

Frequently Asked Questions

Q. What if I don't subscribe to telephone service from my cable operator, can I still use the wireless home gateway to make and receive phone calls?

A. No. Telephone service is enabled for each telephone port on the wireless home gateway by the cable telephony service provider. Contact your cable telephony service provider to get telephone service through the wireless home gateway.

Q. How do I arrange for installation?

A. Professional installation from your cable telephony service provider may be provided. A professional installer can connect the telephone service to your existing telephone wiring in your home or install new wiring if needed. Professional installation also ensures proper cable connection to the modem and to your PC, and ensures proper configuration of all hardware and software settings. Contact your cable telephony service provider for more information about installation.

Q. Can I use my existing phone number with the wireless home gateway?

A. Telephone numbers are portable in some areas. Contact your telephone service provider for more information about using an existing telephone number.

Q. Do I automatically receive high-speed Internet service with the wireless home gateway?

A. Your wireless home gateway may be used to provide telephone service, high-speed Internet service, or both services. Your cable service provider enables Internet service. Contact your cable service provider for more information if you are not currently subscribing to Internet service.

Q. How many telephones can I connect?

A. The RJ-11 telephone-style connectors on the wireless home gateway can each provide telephone service to multiple telephones, fax machines, and analog modems. The maximum number of telephone devices connected to each RJ-11 port is limited by the total Ringing Load of the telephone devices that are connected. Many telephone devices are marked with a Ringer Equivalent Number (REN). Each telephone port on the wireless home gateway can support up to a 5 REN load. The sum of the REN load on all of the telephone devices attached to each port must not exceed 5 REN.

Q. Can I surf the Internet and make telephone calls at the same time?

A. Absolutely! Telephone service is provided separately from Internet data services. Internet surfing and other data services do not affect the quality of your telephone calls. If these services are enabled by your cable service provider, you can make telephone calls and surf the net at the same time.

Having Difficulty?

Common Troubleshooting Suggestions

The modem does not register a cable connection

The modem works with a standard, 75-ohm, RF coaxial cable. If you are using a different cable, your wireless home gateway will not function properly. Contact your service provider to determine whether you are using the correct cable.

There is no dial tone when I lift the telephone handset

- Your telephone wiring may be connected to the wrong RJ-11 port on the wireless home gateway. The wireless home gateway has two telephone ports. Verify that you are connected to the correct telephone port.
- There may be a problem with your telephone set. Use a different telephone set and listen to hear dial tone.
- There may be a problem with your home telephone wiring. Use a telephone and connect directly to the same RJ-11 port on the back of the unit. If the dial tone is working here but does not work at other locations in the home, a professional may need to diagnose and repair a problem with your telephone wiring.
- Verify that the phone company has removed the previous telephone service from your home telephone wiring.
- Your telephone service may not be enabled from your cable telephony service provider. Contact your cable telephony service provider for more information.

Frequently Asked Questions

Q. What if I don't subscribe to cable TV?

A. If cable TV is available in your area, data service may be made available with or without subscribing to cable TV service. Contact your local cable service provider for complete information on cable services, including high-speed Internet access.

Q. How do I arrange for installation?

A. Call your cable telephony service provider to inquire about professional installation. A professional installation ensures proper cable connection to the modem and to your PC, and it ensures the proper configuration of all hardware and software settings. Contact your cable telephony service provider for more information about installation.

Q. How does the wireless home gateway connect to my computer?

A. The wireless home gateway connects to the USB port or the 10/100BaseT Ethernet port on your PC. If your PC is not equipped with an Ethernet interface, an Ethernet card is available from your local PC or office supply retailer, or from your cable service provider.

Q. After my wireless home gateway is connected, how do I access the Internet?

A. Your local service provider becomes your Internet Service Provider (ISP). They offer a wide range of services including e-mail, chat, news, and information services. Your cable service provider will provide the software you will need.

Q. Can I watch TV and surf the Internet at the same time?

A. Absolutely! If you subscribe to cable television service, you can watch TV and use your wireless home gateway at the same time by connecting your TV and your wireless home gateway to the cable network using an optional cable signal splitter.

Q. Can I run more than one device on the modem?

A. Yes. A single wireless home gateway will theoretically support up to 253 Ethernet devices utilizing user-supplied Ethernet hubs or routers that you can purchase at your local PC or office supply retailer. Another user at your location can simultaneously connect to the USB port on the wireless home gateway. Contact your service provider for further assistance.

Common Troubleshooting Issues

I don't understand the front panel status indicators

See *Front Panel LED Status Indicator Functions* (on page 130), for more detailed information on front panel LED status indicator operation and function.

The modem does not register an Ethernet connection

- Verify that your computer has an Ethernet card and that the Ethernet driver software is properly installed. If you purchase and install an Ethernet card, follow the installation instructions very carefully.
- Verify the status of the front panel status indicator lights.

The modem does not register an Ethernet connection after connecting to a hub

If you are connecting multiple PCs to the wireless home gateway, you should first connect the modem to the uplink port of the hub using the correct crossover cable. The LINK LED of the hub will illuminate continuously.

Having Difficulty?

The modem does not register a cable connection

- The modem works with a standard 75-ohm RF coaxial cable. If you are using a different cable, your wireless home gateway will not function properly. Contact your cable service provider to determine whether you are using the correct cable.
- Verify that you have followed the procedures in *How Do I Troubleshoot My Internet Service Installation?* (on page 35).
- Your NIC card or USB interface may be malfunctioning. Refer to the troubleshooting information in the NIC or USB documentation provided with the device.

Tips for Improved Performance

Check and Correct

If your wireless home gateway does not perform as expected, the following tips may help. If you need further assistance, contact your service provider.

- Verify that the plug to your wireless home gateway AC power is properly inserted into an electrical outlet.
- Verify that your wireless home gateway AC power cord is not plugged into an electrical outlet that is controlled by a wall switch. If a wall switch controls the electrical outlet, make sure the switch is in the **ON** position.
- Verify that the **POWER** and **ONLINE** LED status indicators on the front panel of your wireless home gateway are illuminated.
- Verify that all cables are properly connected, and that you are using the correct cables.
- Verify that your cable service is active and that it supports two-way service.
- Verify that your TCP/IP is properly installed and configured if you are using the Ethernet connection.
- Verify that you have followed the procedures in *How Do I Install USB Drivers?* (on page 25), if you are using the USB connection.
- Verify that you have called your service provider and given them the serial number and MAC address of your wireless home gateway.
- If you are using a cable signal splitter so that you can connect the wireless home gateway to other devices, remove the splitter and reconnect the cables so that the wireless home gateway is connected directly to the cable input. If the wireless home gateway now functions properly, the cable signal splitter may be defective and may need to be replaced.
- For best performance over an Ethernet connection, your PC should be equipped with a 10/100BaseT network interface card.

Front Panel LED Status Indicator Functions

Initial Power Up, Calibration, and Registration (AC Power applied)

The following chart illustrates the sequence of steps and the corresponding appearance of the wireless home gateway front panel LED status indicators during power up, calibration, and registration on the network when AC power is applied to the wireless home gateway. Use this chart to troubleshoot the power up, calibration, and registration process of your wireless home gateway.

Note: After the wireless home gateway completes Step 7 (Registration Completed), the modem proceeds immediately to Normal Operations. See *Normal Operations (AC Power applied)* (on page 131).

Front Panel LED Status Indicators During Initial Power Up, Calibration, and Registration								
Step		1	2	3	4	5	6	7
Front Panel Indicator		Self Test	Downstream Scan	Downstream Signal Lock	Ranging	Requesting IP Address	Registering	Registration Completed
1	POWER	ON	ON	ON	ON	ON	ON	ON
2	DS	ON	BLINKING	ON	ON	ON	ON	ON
3	US	ON	OFF	OFF	BLINKING	ON	ON	ON
4	ONLINE	ON	OFF	OFF	OFF	OFF	BLINKING	ON
5	LAN1 through LAN4/USB	ON	ON or BLINKING	ON or BLINKING	ON or BLINKING	ON or BLINKING	ON or BLINKING	ON or BLINKING
6	WIRELESS	ON	ON or BLINKING	ON or BLINKING	ON or BLINKING	ON or BLINKING	ON or BLINKING	
7	TEL1	ON	OFF	OFF	OFF	OFF	OFF	OFF
8	TEL2	ON	OFF	OFF	OFF	OFF	OFF	OFF
9	BATTERY	OFF	OFF	OFF	OFF	OFF	OFF	OFF

* The ONLINE LED is on whenever a PC is connected to the modem, and it blinks to indicate that data is being transferred. If the modem is used to provide telephone service only and is not connected to a PC, the ONLINE LED is off.

Normal Operations (AC Power applied)

The following chart illustrates the appearance of the wireless home gateway front panel LED status indicators during normal operations when AC power is applied to the gateway.

Step		8
Front Panel LED Status Indicators During Normal Operations		
Front Panel Indicator		Normal Operations
1	POWER	ON
2	DS	BLINKS - To indicate data is being transferred between the modem and the network
3	US	BLINKS - To indicate data is being transferred between the modem and the network
4	ONLINE	ON
5	LAN 1 through LAN 4/USB	<p>ON - When a single device is connected to either the Ethernet or USB port and no data is being sent to or from the modem</p> <p>BLINKS - When only one Ethernet or USB device is connected and data is being transferred between the consumer premise equipment (CPE) and the wireless home gateway</p> <p>OFF - When no devices are connected to either the Ethernet or USB ports</p> <p>NOTE: With both Ethernet and USB devices connected to the modem at the same time, when data is being transferred through only one of the devices (Ethernet or USB), the indicator will illuminate continuously. Whenever data is being sent through both data ports (Ethernet and USB) simultaneously, the indicator will blink as described above.</p>
6	WIRELESS	<ul style="list-style-type: none"> ■ ON when the wireless access point is enabled and operational ■ BLINKS when data is being transferred between the CPE and the wireless home gateway ■ OFF when the wireless access point is disabled by the user
7	TEL1	<ul style="list-style-type: none"> ■ ON when telephony service is enabled ■ BLINKS when line 1 is in use
8	TEL2	<ul style="list-style-type: none"> ■ ON when telephony service is enabled ■ BLINKS when line 2 is in use
9	BATTERY	<ul style="list-style-type: none"> ■ ON when battery is charged ■ BLINKS when battery charge is low ■ OFF when there is no battery in the unit

Front Panel LED Status Indicator Functions

Special Conditions

The following chart describes the appearance of the cable modem front panel LED status indicators during special conditions to show when you have been denied network access or when the modem is operating on battery power.

Front Panel LED Status Indicators During Special Conditions			
Front Panel Indicator		Network Access Denied	Operating on Battery Power
1	POWER	Slow Blinking 1 time per second	Slow Blinking 1 time per second
2	DS	Slow Blinking 1 time per second	Off
3	US	Slow Blinking 1 time per second	Off
4	ONLINE	Slow Blinking 1 time per second	Slow Blinking 1 time per second
5	LAN 1 through LAN 4	Slow Blinking 1 time per second	Off
6	WIRELESS	On	Off
7	TEL1	Off	Off
8	TEL2	Off	Off
9	BATTERY	On	Off

Notices

Trademarks

Scientific Atlanta is a registered trademark of Scientific-Atlanta, Inc.

DPC2434 is a trademark of Scientific-Atlanta, Inc.

Cisco, Cisco Systems, and the Cisco Systems logo are registered trademarks of Cisco Systems, Inc. and/or its affiliates in the U.S. and certain other countries.

DOCSIS is a registered trademarks of Cable Television Laboratories, Inc.

PacketCable is a trademark of Cable Television Laboratories, Inc.

Other trademarks listed herein are the property of their respective owners.

Disclaimer

Scientific-Atlanta, Inc. assumes no responsibility for errors or omissions that may appear in this guide. Scientific-Atlanta, Inc. reserves the right to change this guide at any time without notice.

Documentation Copyright Notice

© 2006 Scientific-Atlanta, Inc. All rights reserved.

Printed in the United States of America.

Information in this document is subject to change without notice. No part of this document may be reproduced in any form without the express written permission of Scientific-Atlanta, Inc.

Software Use Notice

The software described in this document is copyrighted and furnished to you under a license agreement. You may only use or copy this software in accordance with the terms of your license agreement.

Firmware Use Notice

The firmware in this equipment is copyrighted. You may only use the firmware in the equipment in which it is provided. Any reproduction or distribution of this firmware, or any portion of it, without express written consent is prohibited.

Notices

FCC Radiation Exposure Statement

This equipment complies with FCC radiation exposure limits set forth for an uncontrolled environment. To maintain compliance with the FCC RF exposure guidelines, this equipment should be installed and operated with minimum distance of at least 7.8 in. (20cm) from all persons.

For Information

If You Have Questions

If you have technical questions, contact your local cable service provider.



Scientific-Atlanta, A Cisco Company
5030 Sugarloaf Parkway, P.O. Box 465477
Lawrenceville, GA 30042

770.236.5000
www.scientificatlanta.com

Product and service availability subject to change without notice.

© 2006 Scientific-Atlanta, Inc. All rights reserved.

Printed in United States of America

August 2006

Part Number 4011350 Rev A