



Radio Test Report

FCC ID: MSQCPVAMW65001

This report concerns (check one) : Original Grant Class I Change

Issued Date : Apr. 20, 2009
Project No. : R0902003
Equipment : Wireless Mouse
Model Name : MW-65X (X=0-9, A-Z or blank)

Applicant : ASUSTeK Computer Inc
Address : NO. 15, LI-TE RD., Peitou, Taipei 112,
Taiwan

Tested by:

Neutron Engineering Inc. EMC Laboratory

Date of Test:

Mar. 31, 2009 ~ Apr. 07, 2009

Testing Engineer : Rush Kao
(Rush Kao)

Technical Manager : Jeff Yang
(Jeff Yang)

Authorized Signatory : Andy Chiu
(Andy Chiu)

Neutron Engineering Inc.

B1, No. 37, Lane 365, YangGuang St.,
NeiHu District 114, Taipei, Taiwan.

TEL: +886-2-2657-3299

FAX: +886-2-2657-3331





Declaration

Neutron represents to the client that testing is done in accordance with standard procedures as applicable and that test instruments used has been calibrated with the standards traceable to National Measurement Laboratory (**NML**) of **R.O.C.**, or National Institute of Standards and Technology (**NIST**) of **U.S.A.**

Neutron's reports apply only to the specific samples tested under conditions. It is manufacture's responsibility to ensure that additional production units of this model are manufactured with the identical electrical and mechanical components. **Neutron** shall have no liability for any declarations, inferences or generalizations drawn by the client or others from **Neutron** issued reports.

Neutron's reports must not be used by the client to claim product endorsement by the authorities or any agency of the Government.

This report is the confidential property of the client. As a mutual protection to the clients, the public and **Neutron-self**, extracts from the test report shall not be reproduced except in full with **Neutron's** authorized written approval.

Neutron's laboratory quality assurance procedures are in compliance with the **ISO Guide 17025** requirements, and accredited by the conformity assessment authorities listed in this test report.

Limitation

For the use of the authority's logo is limited unless the Test Standard(s)/Scope(s)/Item(s) mentioned in this test report is (are) included in the conformity assessment authorities acceptance respective.



Table of Contents	Page
1 . CERTIFICATION	4
2 . SUMMARY OF TEST RESULTS	5
2.1 TEST FACILITY	6
2.2 MEASUREMENT UNCERTAINTY	6
3 . GENERAL INFORMATION	7
3.1 GENERAL DESCRIPTION OF EUT	7
3.2 DESCRIPTION OF TEST MODES	9
3.3 BLOCK DIAGRAM SHOWING THE CONFIGURATION OF SYSTEM TESTED	10
3.4 DESCRIPTION OF SUPPORT UNITS	11
4 . EMC EMISSION TEST	12
4.1 RADIATED EMISSION MEASUREMENT	12
4.1.1 RADIATED EMISSION LIMITS	12
4.1.2 MEASUREMENT INSTRUMENTS LIST	13
4.1.3 TEST PROCEDURE	13
4.1.4 DEVIATION FROM TEST STANDARD	13
4.1.5 TEST SETUP	14
4.1.6 EUT OPERATING CONDITIONS	14
4.1.7 TEST RESULTS-BETWEEN 30MHz – 1000MHz	15
4.1.8 TEST RESULTS-ABOVE 1000MHz	17
4.1.9 TEST RESULTS-2402MHz – 2480MHz	29
4.1.10 TEST RESULTS-RESTRICTED BANDS REQUIREMENTS	30
5 . EUT TEST PHOTO	35



1. CERTIFICATION

Equipment : Wireless Mouse
Brand Name : ASUS
Model No. : MW-65X (X=0-9, A-Z or blank)
Applicant : ASUSTeK Computer Inc
Date of Test : Mar. 31, 2009 ~ Apr. 07, 2009
Test Item : ENGINEERING SAMPLE
Standards : FCC Part15, Subpart C(15.249) / RSS-210: 2004/ ANCI C63.4 : 2003

The above equipment has been tested and found compliance with the requirement of the relative standards by Neutron Engineering Inc. EMC Laboratory.

The test data, data evaluation, and equipment configuration contained in our test report (Ref No. NEI-FCCP-1-R0902003) were obtained utilizing the test procedures, test instruments, test sites that has been accredited by the Authority of NVLAP and TAF according to the ISO-17025 quality assessment standard and technical standard(s).



2. SUMMARY OF TEST RESULTS

Test procedures according to the technical standards:

FCC Part15, Subpart C			
Standard Section	Test Item	Judgment	Remark
15.207	Conducted Emission	N/A	
15.249	Radiated Spurious Emission	PASS	

NOTE:

(1) "N/A" denotes test is not applicable in this Test Report



2.1 TEST FACILITY

The test facilities used to collect the test data in this report is **OS01(FCC R.N.: 95335)** at the location of No.132-1, Lane 329, Sec. 2, Palain Road, Shijr City, Taipei, Taiwan.

Neutron's test firm number is 95335

2.2 MEASUREMENT UNCERTAINTY

The reported uncertainty of measurement $y \pm U$, where expended uncertainty **U** is based on a standard uncertainty multiplied by a coverage factor of **k=2**, providing a level of confidence of approximately **95 %**.

A. Conducted Measurement :

Test Site	Method	Measurement Frequency Range	U , (dB)	NOTE
C01	ANSI	150 KHz ~ 30MHz	1.94	

B. Radiated Measurement :

Test Site	Method	Measurement Frequency Range	Ant. H / V	U , (dB)	NOTE
OS-01	ANSI	30MHz ~ 200MHz	V	2.86	
		30MHz ~ 200MHz	H	2.56	
		200MHz ~ 1,000MHz	V	2.88	
		200MHz ~ 1,000MHz	H	2.98	
OS-02	ANSI	30MHz ~ 200MHz	V	2.48	
		30MHz ~ 200MHz	H	2.16	
		200MHz ~ 1,000MHz	V	2.50	
		200MHz ~ 1,000MHz	H	2.66	



3. GENERAL INFORMATION

3.1 GENERAL DESCRIPTION OF EUT

Equipment	Wireless Mouse												
Brand Name	ASUS												
Model No.	MW-65X (X=0-9, A-Z or blank)												
OEM Brand/Model No.	N/A												
Model Difference	Model MW-65X, X may be 0-9, A-Z or blank. Models' differences between each other only the changes of model name which do not affect the EMI performance. Model MW-65 was used for final testing and collecting test data included in this report.												
Product Description	<p>The EUT is a Wireless Mouse.</p> <table border="1"> <tr> <td>Operation Frequency:</td> <td>2402~2480MHz</td> </tr> <tr> <td>Modulation Type:</td> <td>GFSK</td> </tr> <tr> <td>Number Of Channel</td> <td>7CH</td> </tr> <tr> <td>Antenna Designation:</td> <td>Printer Antenna</td> </tr> <tr> <td>Antenna Gain(Peak)</td> <td>3.82dBi</td> </tr> <tr> <td>Output Power:</td> <td>83.92dBuV/m (Max.)</td> </tr> </table> <p>Based on the application, features, or specification exhibited in User's Manual, the EUT is considered as an ITE/Computing Device. More details of EUT technical specification, please refer to the User's Manual.</p>	Operation Frequency:	2402~2480MHz	Modulation Type:	GFSK	Number Of Channel	7CH	Antenna Designation:	Printer Antenna	Antenna Gain(Peak)	3.82dBi	Output Power:	83.92dBuV/m (Max.)
Operation Frequency:	2402~2480MHz												
Modulation Type:	GFSK												
Number Of Channel	7CH												
Antenna Designation:	Printer Antenna												
Antenna Gain(Peak)	3.82dBi												
Output Power:	83.92dBuV/m (Max.)												
Channel List	Please refer to the Note 2.												
Power Source	Battery supplied												
Power Rating	DC 3V												
Connecting I/O Port(s)	Please refer to the User's Manual												

Note:

1. For a more detailed features description, please refer to the manufacturer's specifications or the User's Manual.



2.

Channel List							
Channel	Frequency (MHz)	Channel	Frequency (MHz)	Channel	Frequency (MHz)	Channel	Frequency (MHz)
01	2402	03	2440	05	2474	07	2480
02	2408	04	2471	06	2477		

3. Table for Filed Antenna

Ant.	Brand	Model Name	Antenna Type	Connector	Gain (dBi)
1	N/A	N/A	Printer Antenna	N/A	3.82



3.2 DESCRIPTION OF TEST MODES

To investigate the maximum EMI emission characteristics generated from EUT, the test system was pre-scanning tested based on the consideration of following EUT operation mode or test configuration mode which possible have effect on EMI emission level. Each of these EUT operation mode(s) or test configuration mode(s) mentioned above was evaluated respectively.

Pretest Test Mode	Description
Mode 1	CH01
Mode 2	CH03
Mode 3	CH07

For Radiated Test	
Final Test Mode	Description
Mode 1	CH01
Mode 2	CH03
Mode 3	CH07



3.3 BLOCK DIAGRAM SHOWING THE CONFIGURATION OF SYSTEM TESTED

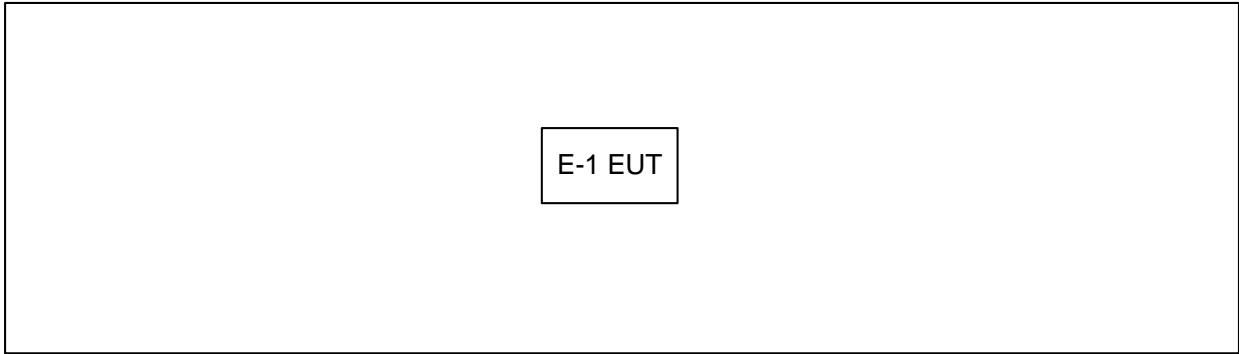



3.4 DESCRIPTION OF SUPPORT UNITS

The EUT has been tested as an independent unit together with other necessary accessories or support units. The following support units or accessories were used to form a representative test configuration during the tests.

Item	Equipment	Mfr/Brand	Model/Type No.	FCC ID	Series No.	Note
E-1	Wireless Mouse	ASUS	MW-65	MSQCPVAMW65001	N/A	EUT

Item	Shielded Type	Ferrite Core	Length	Note
	N/A	N/A	N/A	

Note:

- (1) The support equipment was authorized by Declaration of Confirmation.
- (2) For detachable type I/O cable should be specified the length in cm in 『Length』 column.



4. EMC EMISSION TEST

4.1 RADIATED EMISSION MEASUREMENT

4.1.1 RADIATED EMISSION LIMITS (FCC 15.209)

requencies (MHz)	Field Strength (micorvolts/meter)	Measurement Distance (meters)
0.009~0.490	2400/F(KHz)	300
0.490~1.705	24000/F(KHz)	30
1.705~30.0	30	30
30~88	100	3
88~216	150	3
216~960	200	3
Above 960	500	3

Harmonic emissions limits comply with below 54 dBuV/m at 3m. Other emissions radiated outside of the specified frequency bands, except for harmonics, shall be attenuated by at least 50 dB below the level of the fundamental or comply with the radiated emissions limits specified in section 15.209(a) limit in the table below has to be followed.

Note:

- (1) The tighter limit applies at the band edges.
- (2) Emission level (dBuV/m)=20log Emission level (uV/m).

LIMITS OF RADIATED EMISSION MEASUREMENT (FCC 15.209)

FREQUENCY (MHz)	Class A (dBuV/m) (at 3m)		Class B (dBuV/m) (at 3m)	
	PEAK	AVERAGE	PEAK	AVERAGE
Above 1000	80	60	74	54

Notes:

- (1) The limit for radiated test was performed according to FCC PART 15B.
- (2) The tighter limit applies at the band edges.
- (3) Emission level (dBuV/m)=20log Emission level (uV/m).

LIMITS OF RADIATED EMISSION MEASUREMENT (FCC Part 15.249)

FCC Part15 (15.249) , Subpart C	
Limit	Frequency Range (MHz)
Field strength of fundamental 50000 μV/m (94 dBμV/m) @ 3 m	2400-2483.5
Field strength of harmonics 500 μV/m (54 dBμV/m) @ 3 m	Above 2483.5



4.1.2 MEASUREMENT INSTRUMENTS LIST

Item	Kind of Equipment	Manufacturer	Type No.	Serial No.	Calibrated until
1	Log-Bicon Antenna	Schwarzbeck	VULB 9160	3176	Jul. 24, 2009
2	Test Cable	N/A	10M_OS01	N/A	Oct. 20, 2009
3	Test Cable	N/A	OS01-1/-2	N/A	Oct. 08, 2009
4	Pre-Amplifier	Anritsu	MH648A	M09961	Dec. 29, 2009
5	Spectrum Analyzer	HP	8591EM	3536A006810 10	Mar. 13, 2010
6	EMI Measuring Receiver	SHCAFFNER	SCR 3501	408	Nov. 24.2009
7	Spectrum Analyzer	R&S	FSP-30	100854	Apr. 14, 2009
8	Horn Antenna	Schwarzbeck	BBHA 9120 D	9120D-546	May 27, 2009
9	Microwave Pre_amplifier	Agilent	8449B	3008A02331	Jan. 19, 2010
10	Microflex Cable	NA	NA	1m	Sep. 15, 2009
11	Microflex Cable	NA	NA	10M	Feb. 19, 2010

Remark: " N/A" denotes No Model No. / Serial No. and No Calibration specified.

4.1.3 TEST PROCEDURE

- a. The measuring distance of at 3 m shall be used for measurements at frequency up to 1GHz. For frequencies above 1GHz, any suitable measuring distance may be used.
- b. The EUT was placed on the top of a rotating table 0.8 meters above the ground at a 3m meter open area test site. The table was rotated 360 degrees to determine the position of the highest radiation.
- c. The height of the equipment or of the substitution antenna shall be 0.8 m; the height of the test antenna shall vary between 1 m to 4 m. Both horizontal and vertical polarizations of the antenna are set to make the measurement.
- d. The initial step in collecting conducted emission data is a spectrum analyzer peak detector mode pre-scanning the measurement frequency range. Significant peaks are then marked and then Quasi Peak detector mode re-measured.
- e. If the Peak Mode measured value compliance with and lower than Quasi Peak Mode Limit, the EUT shall be deemed to meet QP Limits and then no additional QP Mode measurement performed.
- f. For the actual test configuration, please refer to the related Item –EUT Test Photos.

4.1.4 DEVIATION FROM TEST STANDARD

No deviation

4.1.5 TEST SETUP

(A) Radiated Emission Test Set-Up, Frequency Below 1000MHz

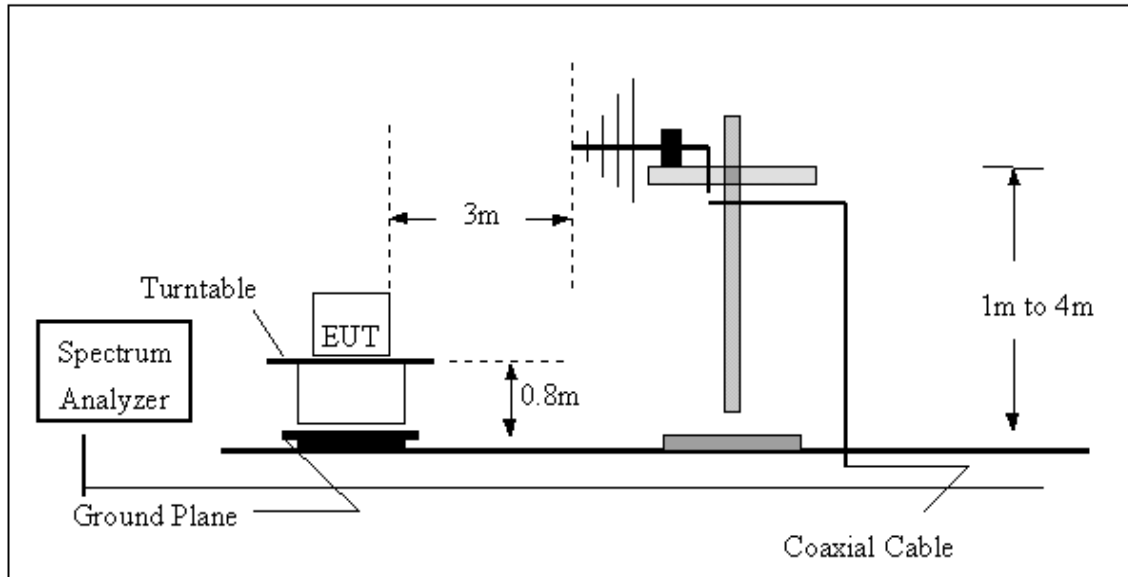

(B) Radiated Emission Test Set-Up Frequency Above 1 GHz

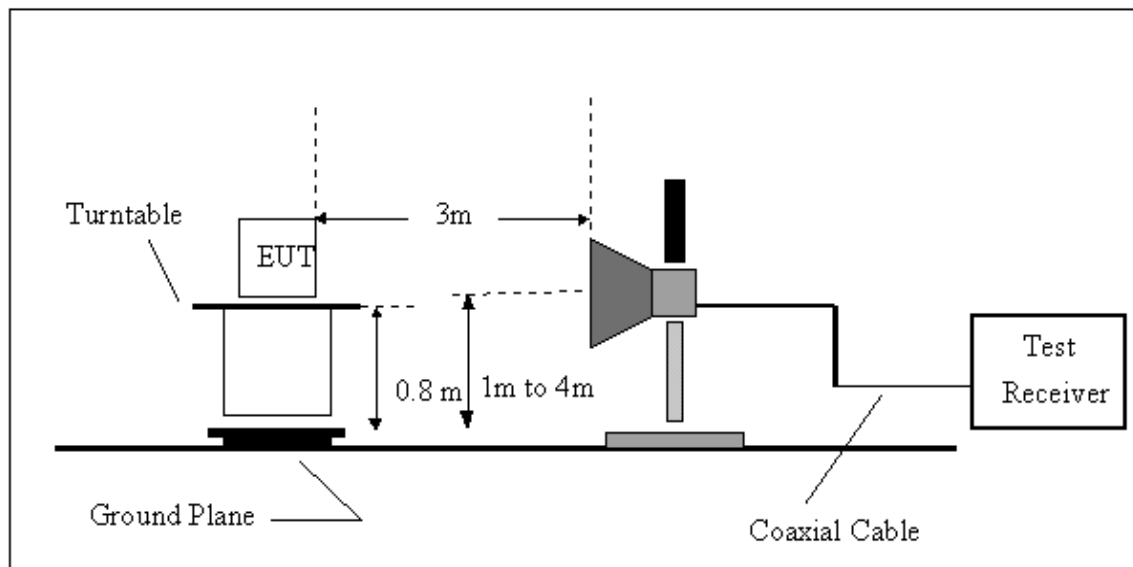

4.1.6 EUT OPERATING CONDITIONS

The EUT was configured for testing in a typical fashion (as a customer would normally use it). The EUT has been programmed to continuously transmit during test. This operation condition was tested and used to collect the included data.



4.1.7 TEST RESULTS-BETWEEN 30MHz – 1000MHz

EUT :	Wireless Mouse	Model No. :	MW-65X
Temperature :	26°C	Relative Humidity :	38%
Test Power :	DC 3V		
Test Mode :	CH03		

Freq. (MHz)	Ant. H/V	Reading(RA) (dBuV)	Corr.Factor(CF) (dB)	Measured(FS) (dBuV/m)	Limits(QP) (dBuV/m)	Margin (dB)	Note
165.86	V	43.38	-13.58	29.80	43.50	- 13.70	
260.88	V	39.69	-13.39	26.30	46.00	- 19.70	
280.26	V	41.23	-12.26	28.97	46.00	- 17.03	
575.20	V	37.57	-3.64	33.93	46.00	- 12.07	
736.10	V	33.59	-0.68	32.91	46.00	- 13.09	
893.30	V	32.27	2.39	34.66	46.00	- 11.34	

Remark :

- (1) Reading in which marked as QP or Peak means measurements by using are Quasi-Peak Mode or Peak Mode with Detector BW=120KHz ; SPA setting in RBW=120KHz, VBW =120KHz, Swp. Time = 0.3 sec./MHz ◦
- (2) All readings are Peak unless otherwise stated QP in column of 『Note』 . Peak denotes that the Peak reading compliance with the QP Limits and then QP Mode measurement didn't perform ◦
- (3) Measuring frequency range from 30MHz to 1000MHz ◦
- (4) If the peak scan value is under the limit for more than 20dB, the signal will not show in table ◦

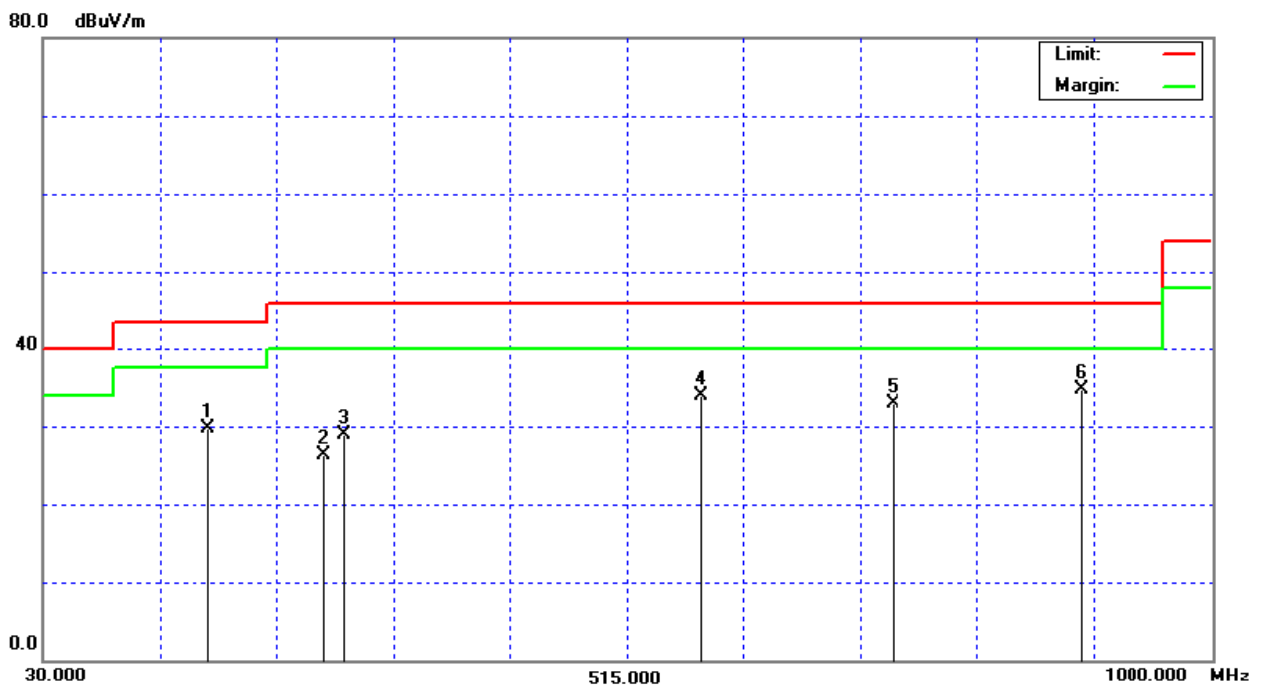



EUT :	Wireless Mouse	Model No. :	MW-65X
Temperature :	26°C	Relative Humidity :	38%
Test Power :	DC 3V		
Test Mode :	CH03		

Freq. (MHz)	Ant. H/V	Reading(RA) (dBuV)	Corr.Factor(CF) (dB)	Measured(FS) (dBuV/m)	Limits(QP) (dBuV/m)	Margin (dB)	Note
95.96	H	43.44	-18.77	24.67	43.50	- 18.83	
132.84	H	44.06	-14.77	29.29	43.50	- 14.21	
266.67	H	41.23	-13.11	28.12	46.00	- 17.88	
392.77	H	39.90	-8.17	31.73	46.00	- 14.27	
592.60	H	35.33	-3.25	32.08	46.00	- 13.92	
807.98	H	34.89	0.96	35.85	46.00	- 10.15	

Remark :

- (1) Reading in which marked as QP or Peak means measurements by using are Quasi-Peak Mode or Peak Mode with Detector BW=120KHz ; SPA setting in RBW=120KHz, VBW =120KHz, Swp. Time = 0.3 sec./MHz ◦
- (2) All readings are Peak unless otherwise stated QP in column of 『Note』 . Peak denotes that the Peak reading compliance with the QP Limits and then QP Mode measurement didn't perform ◦
- (3) Measuring frequency range from 30MHz to 1000MHz ◦
- (4) If the peak scan value is under the limit for more than 20dB, the signal will not show in table ◦

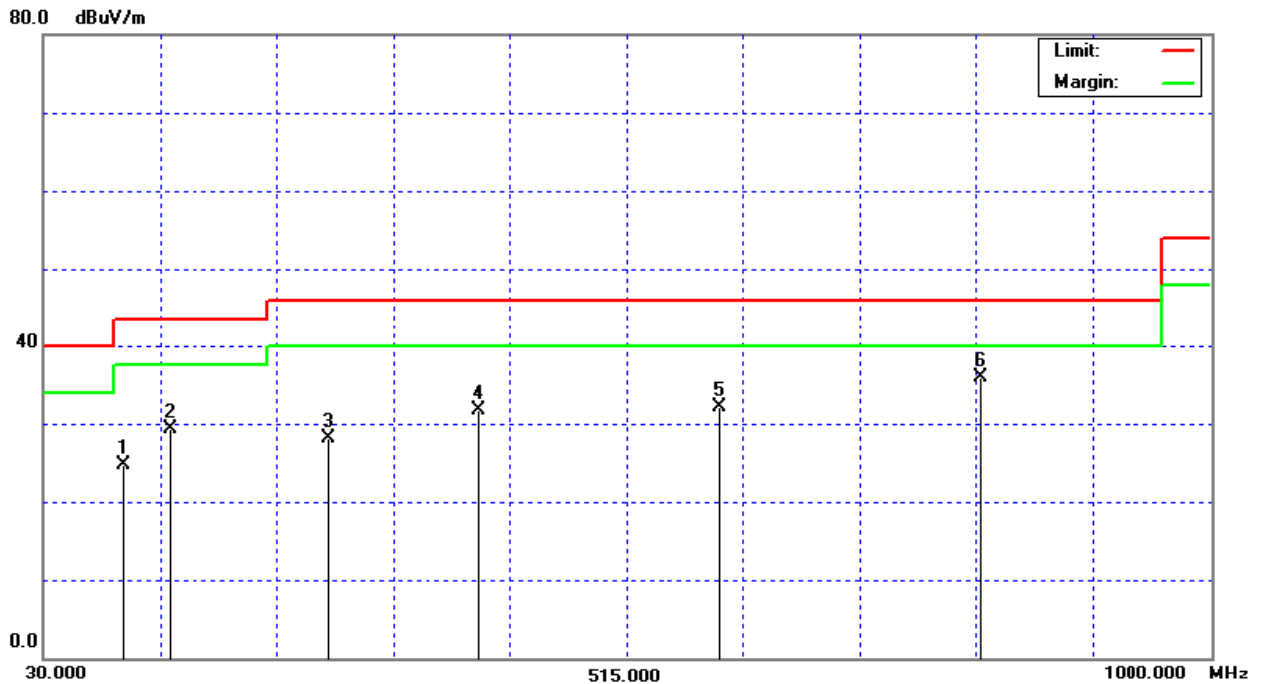



4.1.8 TEST RESULTS-ABOVE 1000MHZ

EUT :	Wireless Mouse	Model No. :	MW-65X
Temperature :	26°C	Relative Humidity :	38%
Test Power :	DC 3V		
Test Mode :	CH01		

Freq. (MHz)	Ant.Pol. H/V	Reading		Ant./CF CF(dB)	Act.		Limit		Note
		Peak (dBuV)	AV (dBuV)		Peak (dBuV/m)	AV (dBuV/m)	Peak (dBuV/m)	AV (dBuV/m)	
2390.00	V	22.98	-0.11	32.57	55.55	32.46	74.00	54.00	X/E
2400.00	V	23.68	0.59	32.63	56.31	33.22	74.00	54.00	X/E
2402.00	V								X/F
4804.10	V	48.46	25.37	4.50	52.96	29.87	74.00	54.00	X/H
7205.92	V	42.98	19.89	11.03	54.01	30.92	74.00	54.00	X/H

Remark :

- (1) All readings are Peak unless otherwise stated QP in column of 『Note』 . Peak denotes that the Peak reading compliance with the QP Limits and then QP Mode measurement didn't perform ◦
- (2) Measuring frequency range from 30MHz to 1000MHz or the 10th harmonic of highest fundamental frequency ◦ "F" denotes fundamental frequency; "H" denotes spurious frequency. "E" denotes band edge frequency. (This judgment method includes the Band Edge Requirement.)
- (3) Radiated emissions measured in frequency range above 1000MHz were made with an instrument using Peak detector mode and AV detector mode of the emission ◦
- (4) Data of measurement within this frequency range shown " * " in the table above means the reading of emissions are attenuated more than 20dB below the permissible limits or the field strength is too small to be measured.
- (5) A preamp and high pass filter were used for this test in order to provide sufficient measurement sensitivity.
- (6) EUT Orthogonal Axes :
"X" - denotes Laid on Table ; "Y" - denotes Vertical Stand ; "Z" - denotes Side Stand



Orthogonal Axes : X
CH01 (Above 1000 MHz, Vertical)

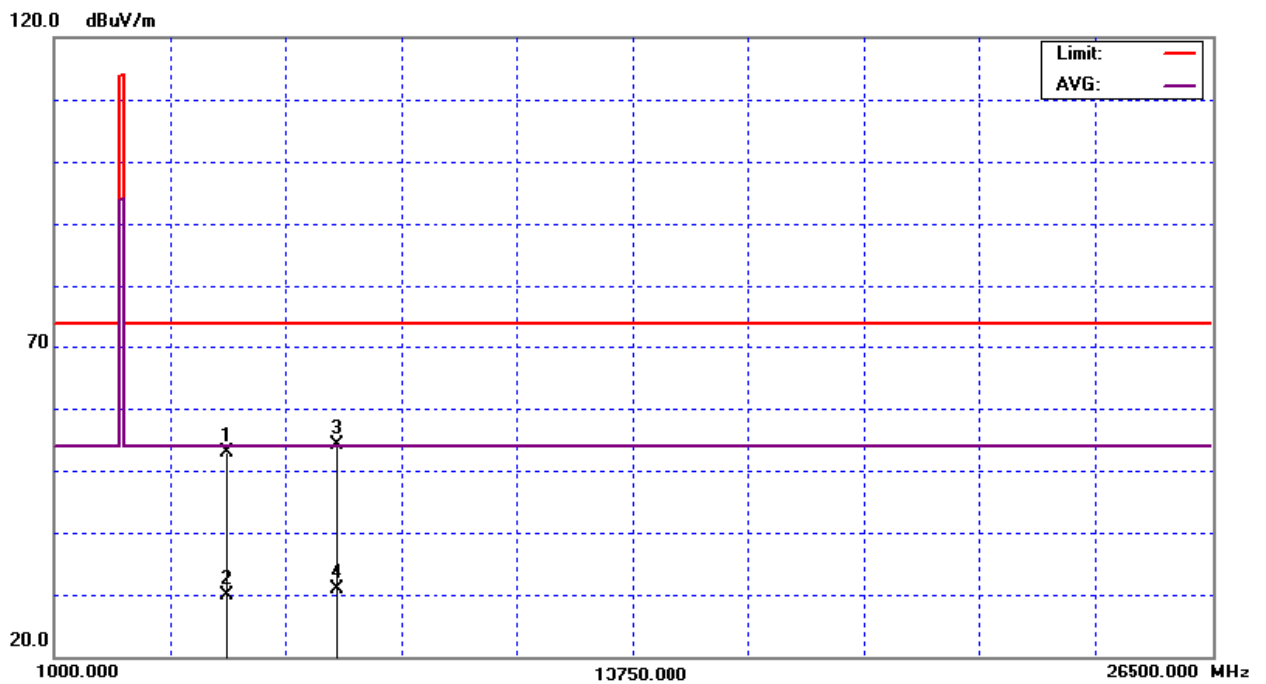
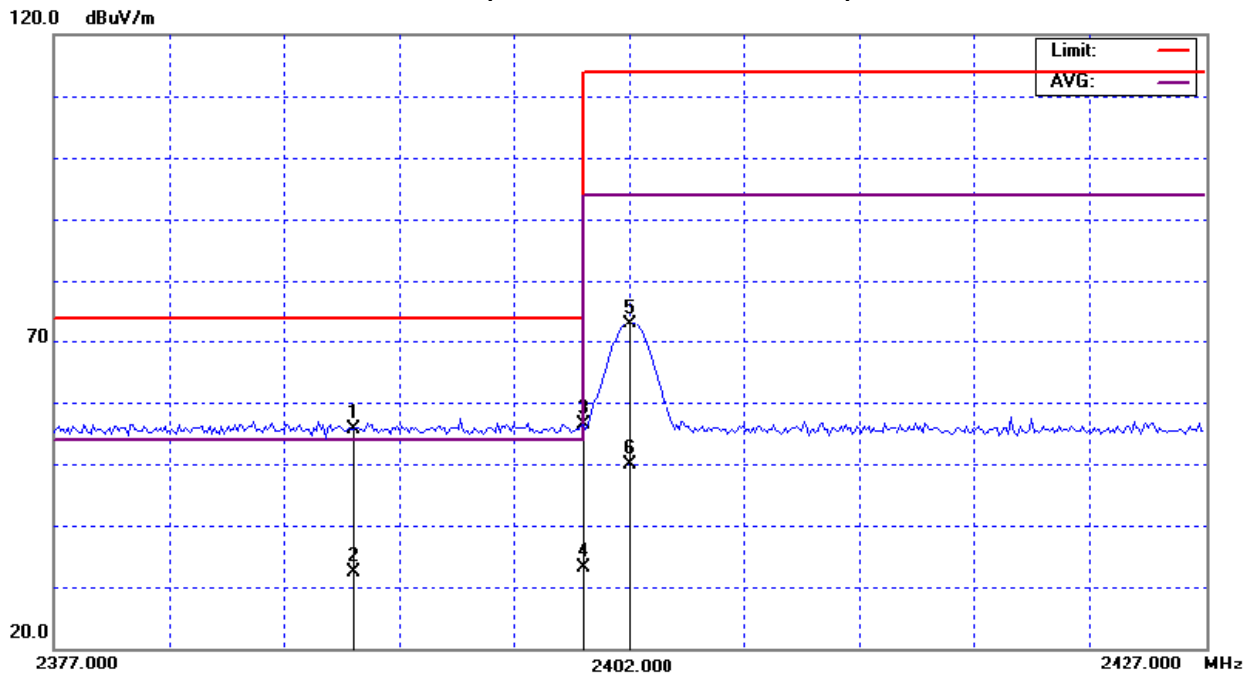



EUT :	Wireless Mouse	Model No. :	MW-65X
Temperature :	26°C	Relative Humidity :	38%
Test Power :	DC 3V		
Test Mode :	CH01		

Freq. (MHz)	Ant.Pol. H/V	Reading		Ant./CF CF(dB)	Act.		Limit		Note
		Peak (dBuV)	AV (dBuV)		Peak (dBuV/m)	AV (dBuV/m)	Peak (dBuV/m)	AV (dBuV/m)	
2390.00	H	23.33	0.24	32.57	55.90	32.81	74.00	54.00	X/E
2400.00	H	32.00	8.91	32.63	64.63	41.54	74.00	54.00	X/E
2402.00	H								X/F
4803.86	H	44.20	21.11	4.50	48.70	25.61	74.00	54.00	X/H
7205.88	H	42.40	19.31	11.03	53.43	30.34	74.00	54.00	X/H

Remark :

- (1) All readings are Peak unless otherwise stated QP in column of 『Note』 . Peak denotes that the Peak reading compliance with the QP Limits and then QP Mode measurement didn't perform ◦
- (2) Measuring frequency range from 30MHz to 1000MHz or the 10th harmonic of highest fundamental frequency ◦ "F" denotes fundamental frequency; "H" denotes spurious frequency. "E" denotes band edge frequency. (This judgment method includes the Band Edge Requirement.)
- (3) Radiated emissions measured in frequency range above 1000MHz were made with an instrument using Peak detector mode and AV detector mode of the emission ◦
- (4) Data of measurement within this frequency range shown " * " in the table above means the reading of emissions are attenuated more than 20dB below the permissible limits or the field strength is too small to be measured.
- (5) A preamp and high pass filter were used for this test in order to provide sufficient measurement sensitivity.
- (6) EUT Orthogonal Axes :
 "X" - denotes Laid on Table ; "Y" - denotes Vertical Stand ; "Z" - denotes Side Stand



Orthogonal Axes : X
CH01 (Above 1000 MHz, Horizontal)

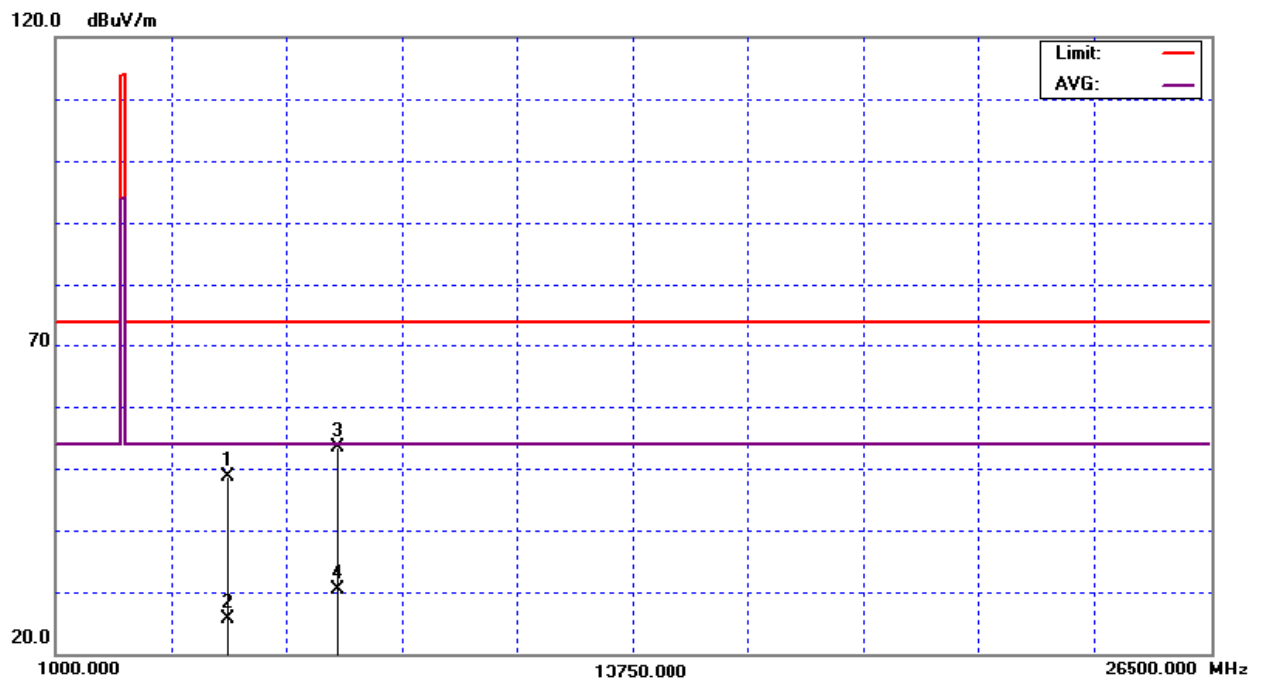
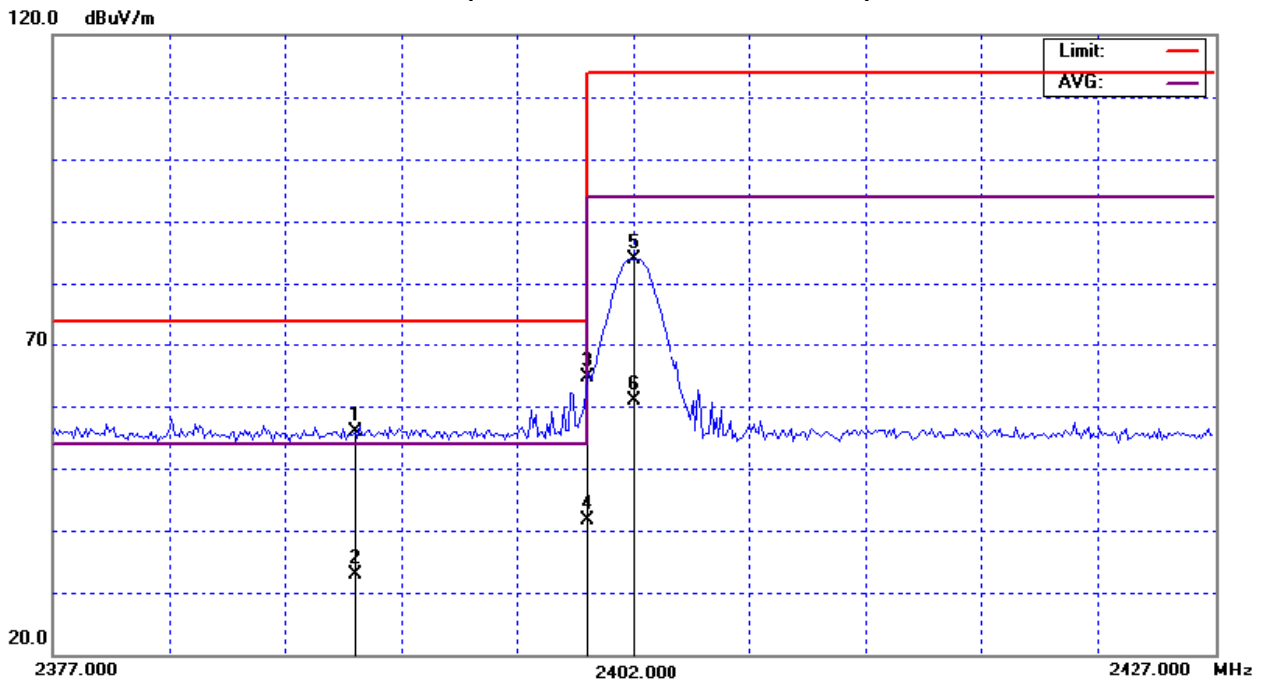



EUT :	Wireless Mouse	Model No. :	MW-65X
Temperature :	26°C	Relative Humidity :	38%
Test Power :	DC 3V		
Test Mode :	CH03		

Freq. (MHz)	Ant.Pol. H/V	Reading		Ant./CF CF(dB)	Act.		Limit		Note
		Peak (dBuV)	AV (dBuV)		Peak (dBuV/m)	AV (dBuV/m)	Peak (dBuV/m)	AV (dBuV/m)	
2440.20	V								X/F
4880.20	V	49.44	26.35	4.75	54.19	31.10	74.00	54.00	X/H
7319.90	V	43.48	20.39	11.39	54.87	31.78	74.00	54.00	X/H

Remark :

- (1) All readings are Peak unless otherwise stated QP in column of 『Note』 . Peak denotes that the Peak reading compliance with the QP Limits and then QP Mode measurement didn't perform ◦
- (2) Measuring frequency range from 30MHz to 1000MHz or the 10th harmonic of highest fundamental frequency ◦ "F" denotes fundamental frequency; "H" denotes spurious frequency. "E" denotes band edge frequency. (This judgment method includes the Band Edge Requirement.)
- (3) Radiated emissions measured in frequency range above 1000MHz were made with an instrument using Peak detector mode and AV detector mode of the emission ◦
- (4) Data of measurement within this frequency range shown " * " in the table above means the reading of emissions are attenuated more than 20dB below the permissible limits or the field strength is too small to be measured.
- (5) A preamp and high pass filter were used for this test in order to provide sufficient measurement sensitivity.
- (6) EUT Orthogonal Axes :
 "X" - denotes Laid on Table ; "Y" - denotes Vertical Stand ; "Z" - denotes Side Stand



Orthogonal Axes : X
CH03(Above 1000 MHz, Vertical)

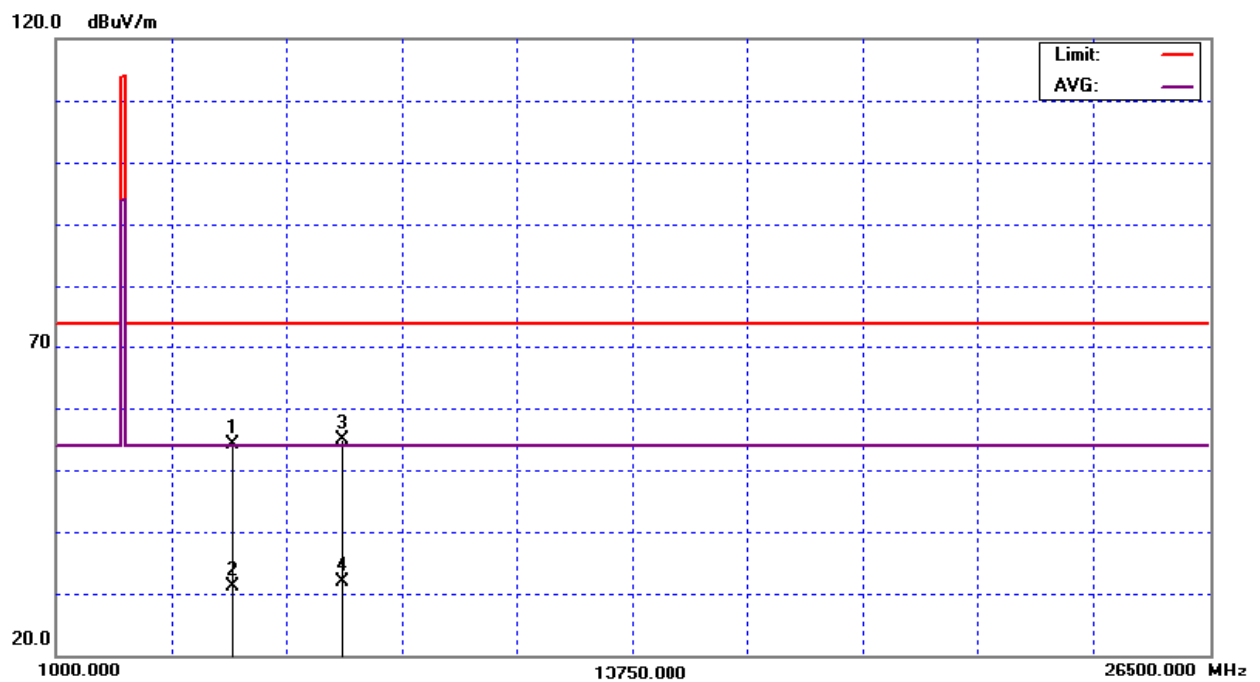
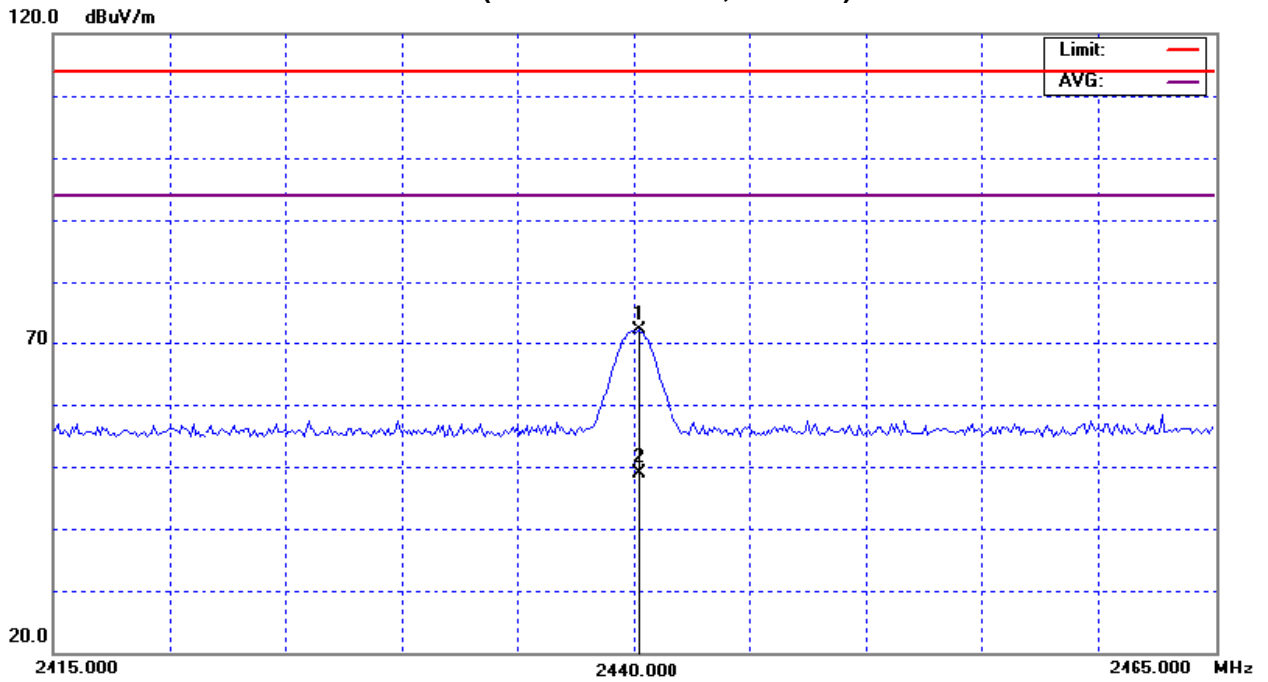



EUT :	Wireless Mouse	Model No. :	MW-65X
Temperature :	26°C	Relative Humidity :	38%
Test Power :	DC 3V		
Test Mode :	CH03		

Freq. (MHz)	Ant.Pol. H/V	Reading		Ant./CF CF(dB)	Act.		Limit		Note
		Peak (dBuV)	AV (dBuV)		Peak (dBuV/m)	AV (dBuV/m)	Peak (dBuV/m)	AV (dBuV/m)	
2440.10	H								X/F
4880.08	H	44.37	21.28	4.75	49.12	26.03	74.00	54.00	X/H
7319.70	H	43.12	20.03	11.39	54.51	31.42	74.00	54.00	X/H

Remark :

- (1) All readings are Peak unless otherwise stated QP in column of 『Note』 . Peak denotes that the Peak reading compliance with the QP Limits and then QP Mode measurement didn't perform ◦
- (2) Measuring frequency range from 30MHz to 1000MHz or the 10th harmonic of highest fundamental frequency ◦ "F" denotes fundamental frequency; "H" denotes spurious frequency. "E" denotes band edge frequency. (This judgment method includes the Band Edge Requirement.)
- (3) Radiated emissions measured in frequency range above 1000MHz were made with an instrument using Peak detector mode and AV detector mode of the emission ◦
- (4) Data of measurement within this frequency range shown " * " in the table above means the reading of emissions are attenuated more than 20dB below the permissible limits or the field strength is too small to be measured.
- (5) A preamp and high pass filter were used for this test in order to provide sufficient measurement sensitivity.
- (6) EUT Orthogonal Axes :
 "X" - denotes Laid on Table ; "Y" - denotes Vertical Stand ; "Z" - denotes Side Stand



Orthogonal Axes : X
CH03(Above 1000 MHz, Horizontal)

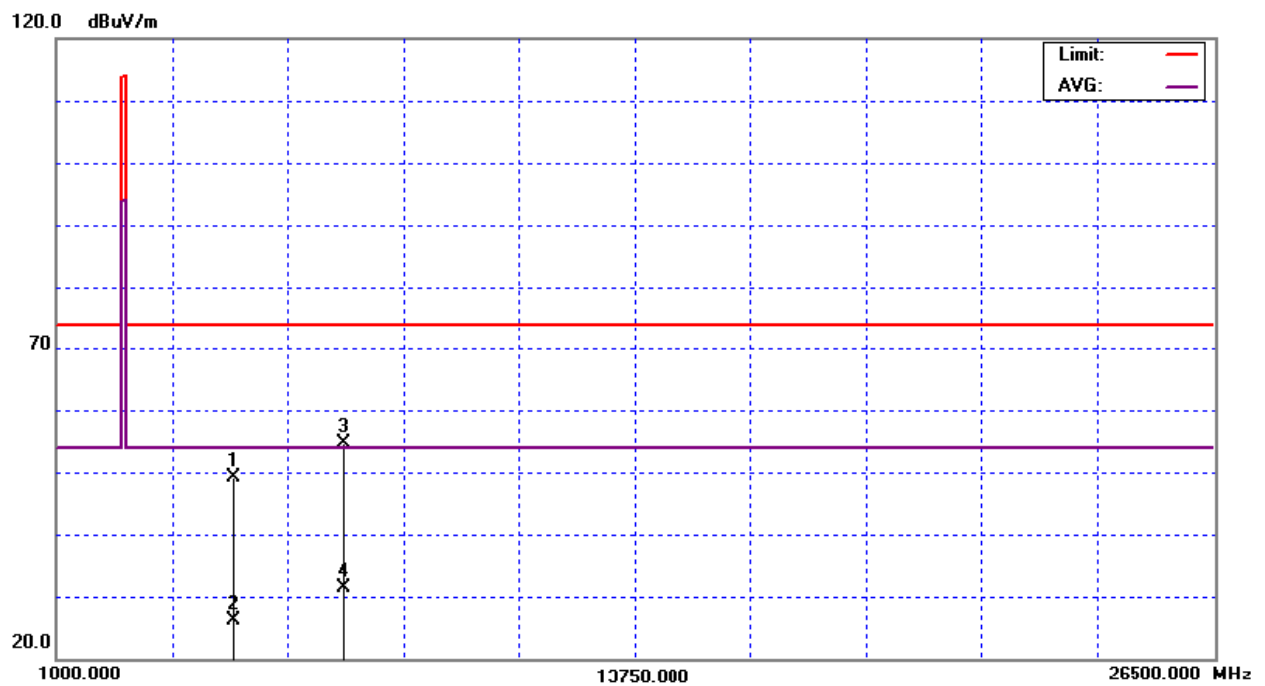
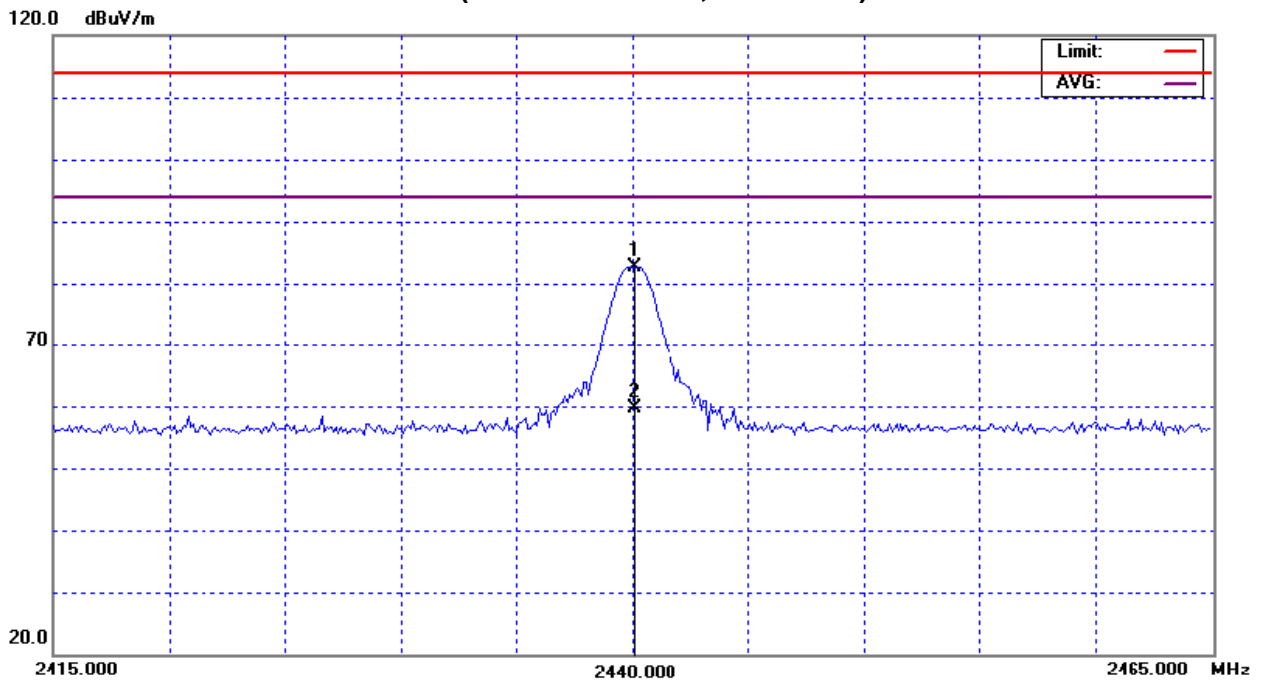



EUT :	Wireless Mouse	Model No. :	MW-65X
Temperature :	26°C	Relative Humidity :	38%
Test Power :	DC 3V		
Test Mode :	CH07		

Freq. (MHz)	Ant.Pol. H/V	Reading		Ant./CF CF(dB)	Act.		Limit		Note
		Peak (dBuV)	AV (dBuV)		Peak (dBuV/m)	AV (dBuV/m)	Peak (dBuV/m)	AV (dBuV/m)	
2480.00	V								X/F
2483.50	V	22.82	-0.27	33.10	55.92	32.83	74.00	54.00	X/E
4960.16	V	47.33	24.24	5.01	52.34	29.25	74.00	54.00	X/H
7439.84	V	43.23	20.14	11.76	54.99	31.90	74.00	54.00	X/H

Remark :

- (1) All readings are Peak unless otherwise stated QP in column of 『Note』 . Peak denotes that the Peak reading compliance with the QP Limits and then QP Mode measurement didn't perform ◦
- (2) Measuring frequency range from 30MHz to 1000MHz or the 10th harmonic of highest fundamental frequency ◦“F” denotes fundamental frequency; “H” denotes spurious frequency. “E” denotes band edge frequency. (This judgment method includes the Band Edge Requirement.)
- (3) Radiated emissions measured in frequency range above 1000MHz were made with an instrument using Peak detector mode and AV detector mode of the emission ◦
- (4) Data of measurement within this frequency range shown “ * ” in the table above means the reading of emissions are attenuated more than 20dB below the permissible limits or the field strength is too small to be measured.
- (5) A preamp and high pass filter were used for this test in order to provide sufficient measurement sensitivity.
- (6) EUT Orthogonal Axes :
 “X” - denotes Laid on Table ; ”Y” - denotes Vertical Stand ; ”Z” - denotes Side Stand



Orthogonal Axes : X
CH07 (Above 1000 MHz, Vertical)

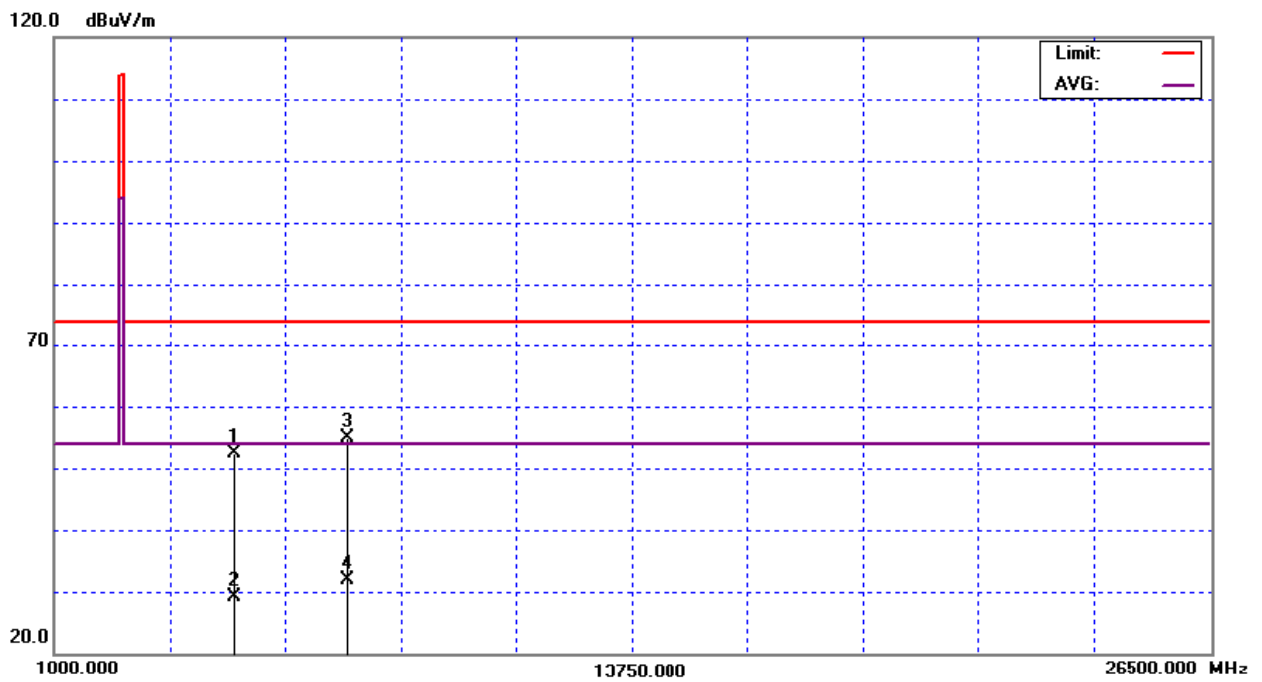
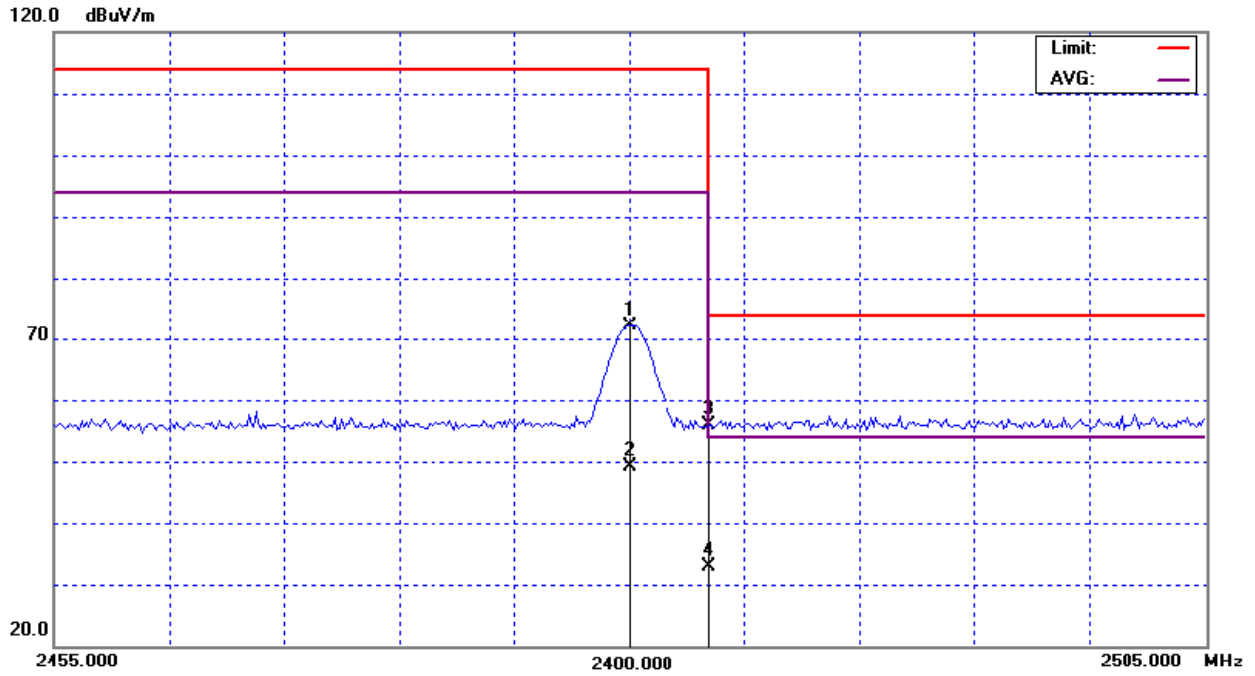



EUT :	Wireless Mouse	Model No. :	MW-65X
Temperature :	26°C	Relative Humidity :	38%
Test Power :	DC 3V		
Test Mode :	CH07		

Freq. (MHz)	Ant. Pol. H/V	Reading		Ant./CF CF(dB)	Act.		Limit		Note
		Peak (dBuV)	AV (dBuV)		Peak (dBuV/m)	AV (dBuV/m)	Peak (dBuV/m)	AV (dBuV/m)	
2480.20	H								X/F
2483.70	H	26.66	3.57	33.10	59.76	36.67	74.00	54.00	X/E
4959.78	H	43.19	20.10	5.01	48.20	25.11	74.00	54.00	X/H
7440.08	H	43.04	19.95	11.76	54.80	31.71	74.00	54.00	X/H

Remark :

- (1) All readings are Peak unless otherwise stated QP in column of 『Note』 . Peak denotes that the Peak reading compliance with the QP Limits and then QP Mode measurement didn't perform ◦
- (2) Measuring frequency range from 30MHz to 1000MHz or the 10th harmonic of highest fundamental frequency ◦ “F” denotes fundamental frequency; “H” denotes spurious frequency. “E” denotes band edge frequency. (This judgment method includes the Band Edge Requirement.)
- (3) Radiated emissions measured in frequency range above 1000MHz were made with an instrument using Peak detector mode and AV detector mode of the emission ◦
- (4) Data of measurement within this frequency range shown “ * ” in the table above means the reading of emissions are attenuated more than 20dB below the permissible limits or the field strength is too small to be measured.
- (5) A preamp and high pass filter were used for this test in order to provide sufficient measurement sensitivity.
- (6) EUT Orthogonal Axes :
 “X” - denotes Laid on Table ; “Y” - denotes Vertical Stand ; “Z” - denotes Side Stand



Orthogonal Axes : X
CH07 (Above 1000 MHz, Horizontal)

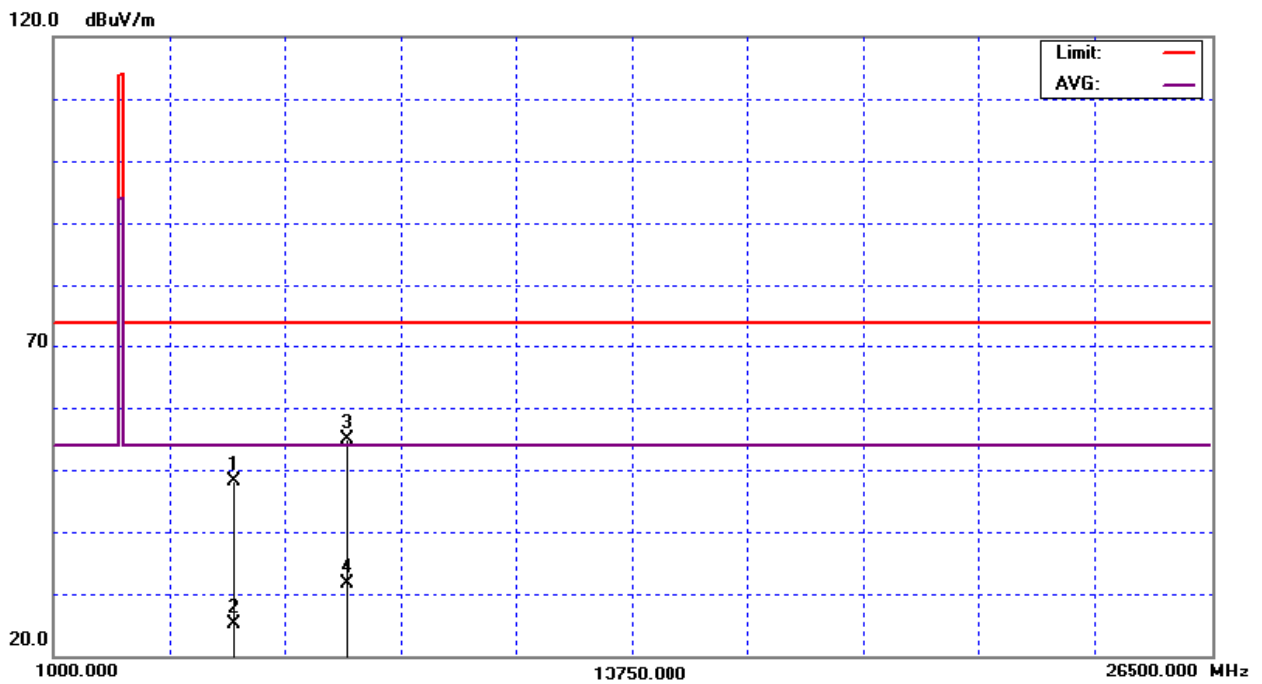
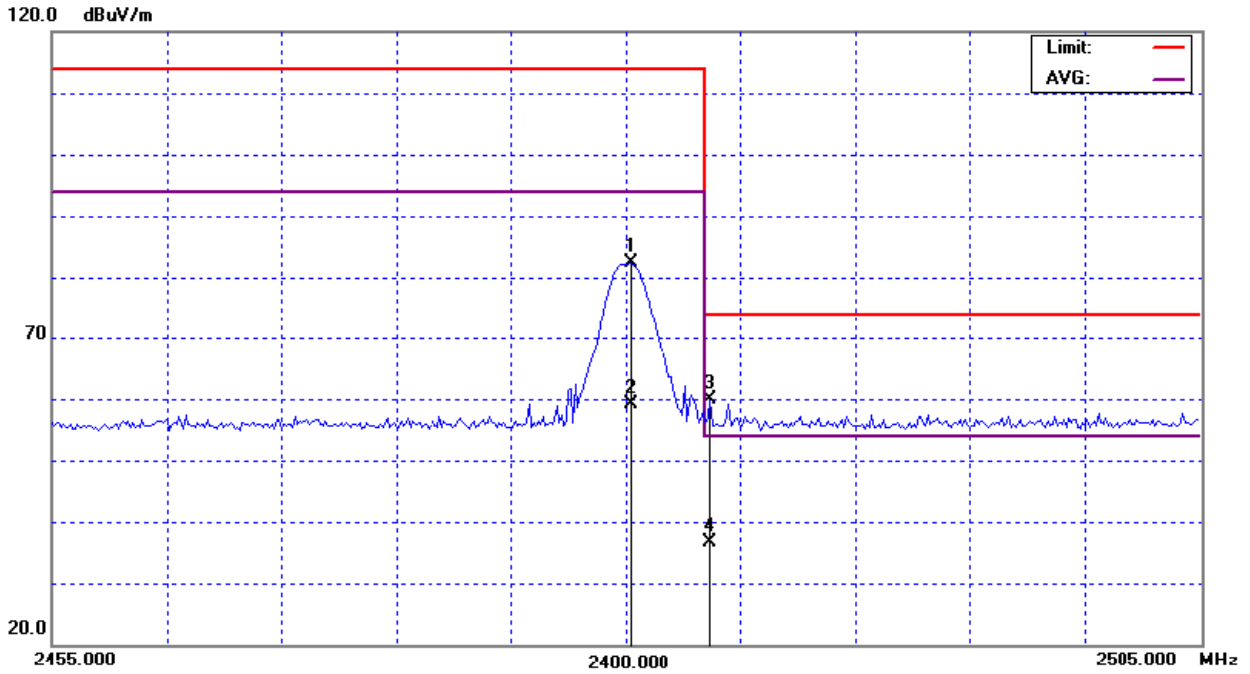



4.1.9 TEST RESULTS-2402MHz – 2480MHz

EUT :	Wireless Mouse	Model No. :	MW-65X
Temperature :	26°C	Relative Humidity :	38%
Test Power :	DC 3V		
Test Mode :	TX CH 2402MHz/2440MHz/2480MHz		

Freq. (MHz)	Ant.Pol. (H/V)	Reading		Ant./CF CF(dB)	Actual FS		Limit3m		Note
		Peak (dBuV)	AV (dBuV)		Peak (dBuV/m)	AV (dBuV/m)	Peak (dBuV/m)	AV (dBuV/m)	
2402.00	V	40.34	17.25	32.64	72.98	49.89	114.00	94.00	CH01
2402.00	H	51.28	28.19	32.64	83.92	60.83	114.00	94.00	CH01
2440.20	V	39.20	16.11	32.86	72.06	48.97	114.00	94.00	CH03
2440.10	H	49.84	26.75	32.85	82.69	59.60	114.00	94.00	CH03
2480.00	V	39.13	16.04	33.08	72.21	49.12	114.00	94.00	CH07
2480.20	H	49.18	26.09	33.08	82.26	59.17	114.00	94.00	CH07

Remark :

- (1) All readings are Peak unless otherwise stated QP in column of 『Note』 . Peak denotes that the Peak reading compliance with the QP Limits and then QP Mode measurement didn't perform ◦
- (2) Radiated emissions measured in frequency range above 1000MHz were made with an instrument using Peak detector mode and AV detector mode of the emission ◦
- (3) Data of measurement within this frequency range shown “ * ” in the table above means the reading of emissions are attenuated more than 20dB below the permissible limits or the field strength is too small to be measured.
- (4) EUT Orthogonal Axes :
 “X” - denotes Laid on Table ; “Y” - denotes Vertical Stand ; “Z” - denotes Side Stand



4.1.10 TEST RESULTS-RESTRICTED BANDS REQUIREMENTS

EUT :	Wireless Mouse	Model No. :	MW-65X
Temperature :	26°C	Relative Humidity :	38%
Test Power :	DC 3V		
Test Mode :	TX CH 2402MHz/2480MHz(Vertical)		
Note :	<p>The emission of the carrier radiated field strength is measured for (Peak and AV) as following:</p> <ol style="list-style-type: none"> 1. The transmitter was then configured with the worst case antenna and setup to transmit at the lowest channel (CH01). Then the field strength was measured at 2310-2390 MHz. 2. The transmitter was configured with the worst case antenna and setup to transmit at the highest channel (CH07). Then the field strength was measured at 2483.5-2500 MHz. 		

Freq. (MHz)	Ant.Pol. H/V	Reading		Ant./CF CF(dB)	Act.		Limit		Note
		Peak (dBuV)	AV (dBuV)		Peak (dBuV/m)	AV (dBuV/m)	Peak (dBuV/m)	AV (dBuV/m)	
2390.00	V	22.98	-0.11	32.57	55.55	32.46	74.00	54.00	CH01
2483.50	V	22.82	-0.27	33.10	55.92	32.83	74.00	54.00	CH07

Remark :

- (1) Radiated emissions measured in frequency range above 1000MHz were made with an instrument using Peak detector mode and AV detector mode of the emission ◦
- (2) EUT Orthogonal Axes :
 "X" - denotes Laid on Table ; "Y" - denotes Vertical Stand ; "Z" - denotes Side Stand



TX CH01 (Restricted Bands Requirements, Vertical)

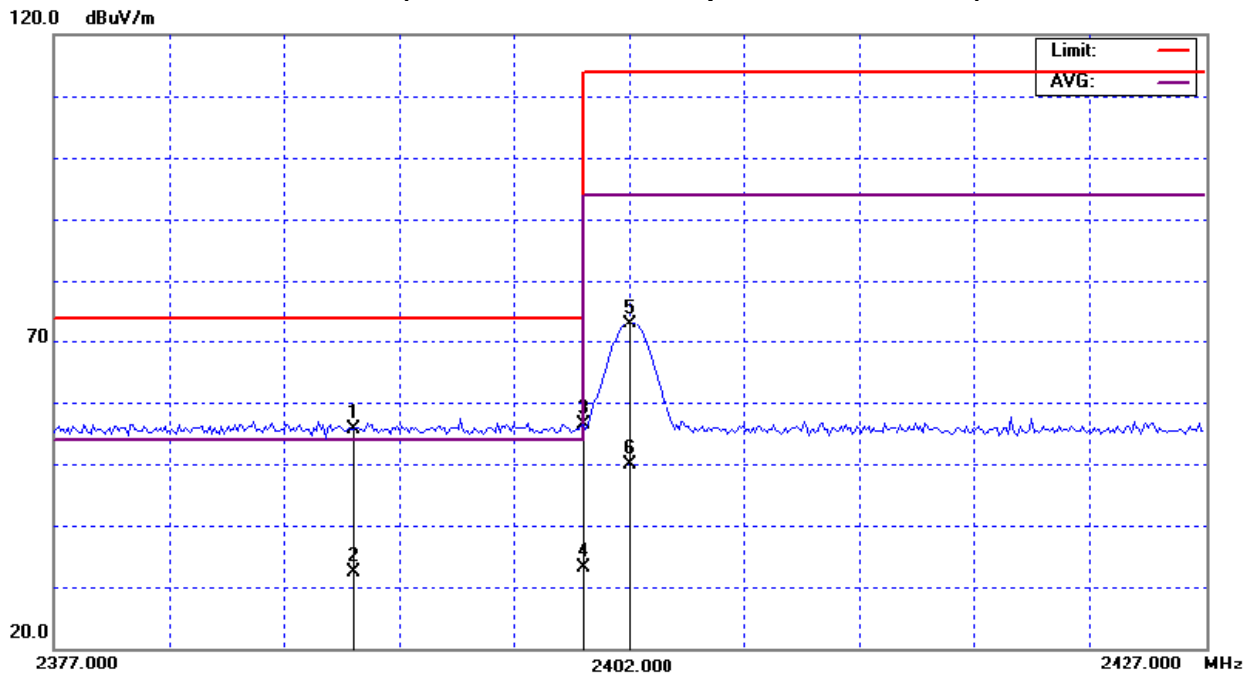

TX CH07 (Restricted Bands Requirements, Vertical)

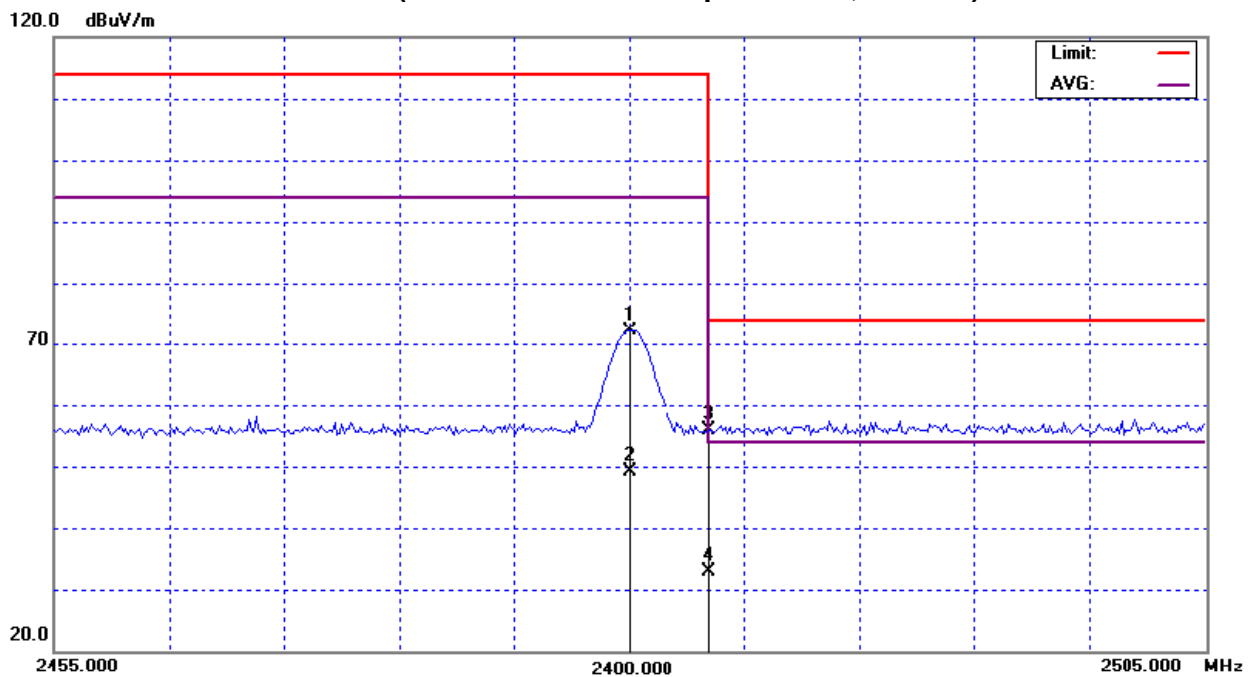



EUT :	Wireless Mouse	Model No. :	MW-65X
Temperature :	26°C	Relative Humidity :	38%
Test Power :	DC 3V		
Test Mode :	TX CH 2402MHz/2480MHz (Horizontal)		
Note :	<p>The emission of the carrier radiated field strength is measured for (Peak and AV) as following:</p> <ol style="list-style-type: none"> 1. The transmitter was then configured with the worst case antenna and setup to transmit at the lowest channel (CH01). Then the field strength was measured at 2310-2390 MHz. 2. The transmitter was configured with the worst case antenna and setup to transmit at the highest channel (CH07). Then the field strength was measured at 2483.5-2500 MHz. 		

Freq. (MHz)	Ant.Pol. H/V	Reading		Ant./CF CF(dB)	Act.		Limit		Note
		Peak (dBuV)	AV (dBuV)		Peak (dBuV/m)	AV (dBuV/m)	Peak (dBuV/m)	AV (dBuV/m)	
2390.00	H	23.33	0.24	32.57	55.90	32.81	74.00	54.00	CH01
2483.70	H	26.66	3.57	33.10	59.76	36.67	74.00	54.00	CH07

Remark :

- (1) Radiated emissions measured in frequency range above 1000MHz were made with an instrument using Peak detector mode and AV detector mode of the emission ◦
- (2) EUT Orthogonal Axes :
 "X" - denotes Laid on Table ; "Y" - denotes Vertical Stand ; "Z" - denotes Side Stand



TX CH01 (Restricted Bands Requirements, Horizontal)

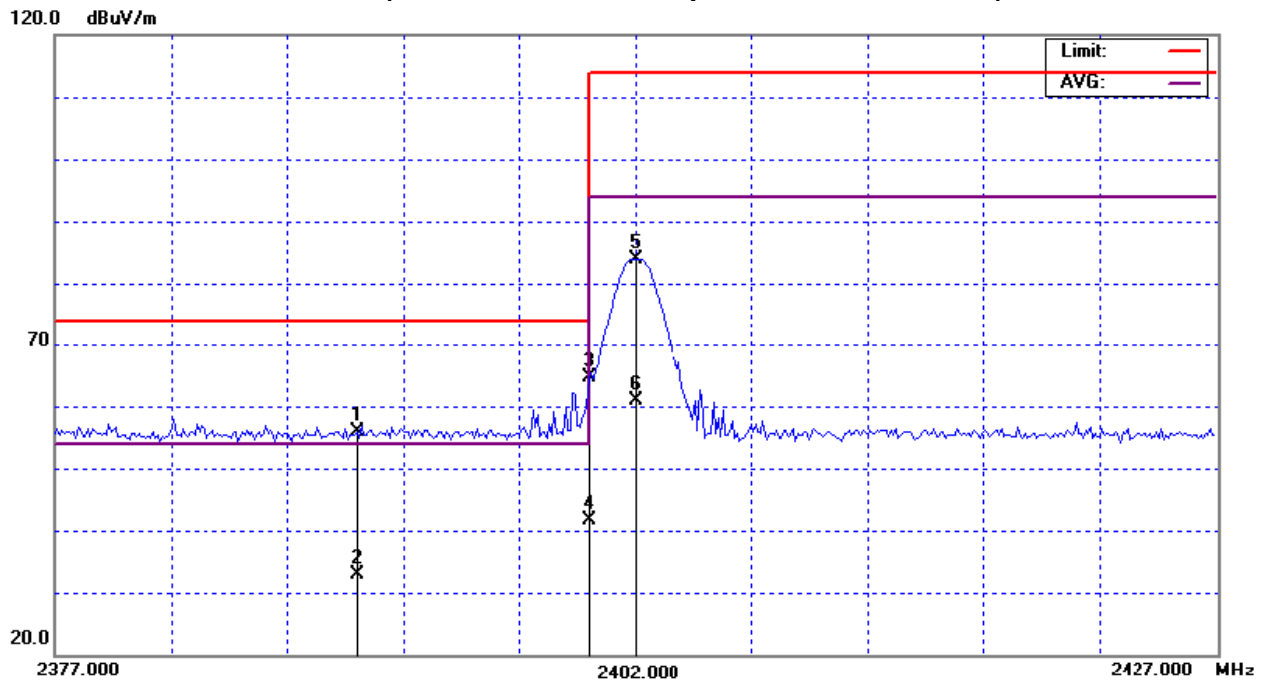

TX CH07 (Restricted Bands Requirements, Horizontal)

