

TAS Algorithm Validation Report for FCC

Applicant Name : ASUSTeK COMPUTER INC.
Applicant Address : 1F., No. 15, Lide Rd., Beitou Dist., Taipei City 112, Taiwan
Product Name : Intel® Wi-Fi 6E AX211
Brand Name : Intel
Model Number : AX211D2W
FCC ID : MSQAX211D2

Report Number : USSC23D039001
Compliant Standards : FCC 47 CFR §2.1093
Sample Received Date : Dec. 05, 2023
Date of Testing : Dec. 14, 2023 ~ Dec. 19, 2023
Report Issue Date : Dec. 26, 2023

The above equipment have been tested by **Eurofins E&E Wireless Taiwan Co., Ltd.**, and found compliance with the requirement of the above standards. The test record, data evaluation & Device Under Test (DUT) configurations represented herein are true and accurate accounts of the measurements of the sample's characteristics under the conditions specified in this report.

Note:

1. The test results are valid only for samples provided by customers and under the test conditions described in this report.
2. This report shall not be reproduced except in full, without the written approval of Eurofins E&E Wireless Taiwan Co., Ltd.
3. The relevant information is provided by customers in this test report. According to the correctness, appropriateness or completeness of the information provided by the customer, if there is any doubt or error in the information which affects the validity of the test results, the laboratory does not take the responsibility.

Approved By :

Roy Wu / Technical Director

Table of Contents

Revision History	3
1. Information of Testing Laboratory	4
2. Device Under Test Information.....	5
3. TAS Validation Test System	6
3.1. Conducted Power Test Setup.....	6
4. Test Result for TAS Validation	7
4.1. Maximum SAR Tune-up Power per SAR Assessment	7
4.2. TAS Validation for 2.4 GHz Band	7
4.3. TAS Validation for 5 GHz Band	9
5. Conclusions for Time-Averaging Feature Validation	11
6. Equipment List.....	12

1. Information of Testing Laboratory

Test Facilities

Company Name: Eurofins E&E Wireless Taiwan Co., Ltd.
 Address No.: 140-1, Changan Street, Bade District, Taoyuan City 334025, Taiwan
 Website: <https://www.atl.com.tw>
 Telephone: +886-3-271-0188
 Fax: +886-3-271-0190
 E-mail: infoEETW@eurofins.com

Test Site Location

- No. 140-1, Changan Street, Bade District, Taoyuan City 334025, Taiwan
- No. 2, Wuquan 5th Rd. Wugu Dist., New Taipei City, Taiwan

Laboratory Accreditation

Location	TAF	FCC	ISED
No. 140-1, Changan Street, Bade District, Taoyuan City 334025, Taiwan	Accreditation No.: 1330	Designation No.: TW0010	Company No.: 7381A CAB ID: TW1330
No. 2, Wuquan 5th Rd. Wugu Dist., New Taipei City, Taiwan	Accreditation No.: 1330	Designation No.: TW0034	Company No.: 28922 CAB ID: TW1330

2. Device Under Test Information

Product Name	Intel® WI-FI 6E AX211	
Brand Name	Intel	
Model Name	AX211D2W	
FCC ID	MSQAX211D2	
Host Information	Product Name: Notebook PC Trade Name: ASUS Model Name: UX8406M, BX8406M, RX8406M	
Supported Wireless Technologies	Tx Frequency (MHz)	Operating Mode
	WLAN 2.4G : 2400.0 ~ 2483.5 5G : 5150 ~ 5250, 5250 ~ 5350, 5470 ~ 5725, 5725 ~ 5850, 5850 ~ 5895 6G : 5925 ~ 7125	2.4G : 802.11b/g/n/ax 5G : 802.11a/n/ac/ax 6G : 802.11ax
	Bluetooth 2400.0 ~ 2483.5	BDR, EDR, LE

Note:

The above DUT information is declared by manufacturer and for more detailed features description please refers to the manufacturer's specifications or User's Manual.

Time-Averaging for SAR

This device is enabled with Intel time-averaging algorithm to control and manage Wi-Fi transmitting power in real time and to ensure that the time-averaged RF exposure for Wi-Fi is in compliance with FCC requirements.

The compliance test under the static transmission scenario and simultaneous transmission analysis are reported in **SAR Evaluation Report**. The validation of the time-averaging algorithm and compliance under the dynamic (time-varying) transmission scenario for Wi-Fi technology is reported in this **TAS Algorithm Validation Report**.

3. TAS Validation Test System

3.1. Conducted Power Test Setup

The TAS algorithm is validated through conducted power measurement and the test setup is described in the following and illustrated in *Figure 3-1*.

- The DUT which AX211D2W Wi-Fi module is installed inside Notebook Computer from ASUS model UX8406M.
- A control PC is used to configure the call box as an access point to manage the uplink and downlink data traffic.
- Uplink signal power is measured with the spectrum analyzer and recorded by the control PC with a maximum time resolution of 0.3333 millisecond.
- Uplink signal from the module is fed through a 3 dB power splitter, which delivers an equal amount of signal to the spectrum analyzer and the call box. The splitter has high isolation between the spectrum analyzer and the call box.

Figure 3-1: Conducted Power Test Setup for TAS Validation

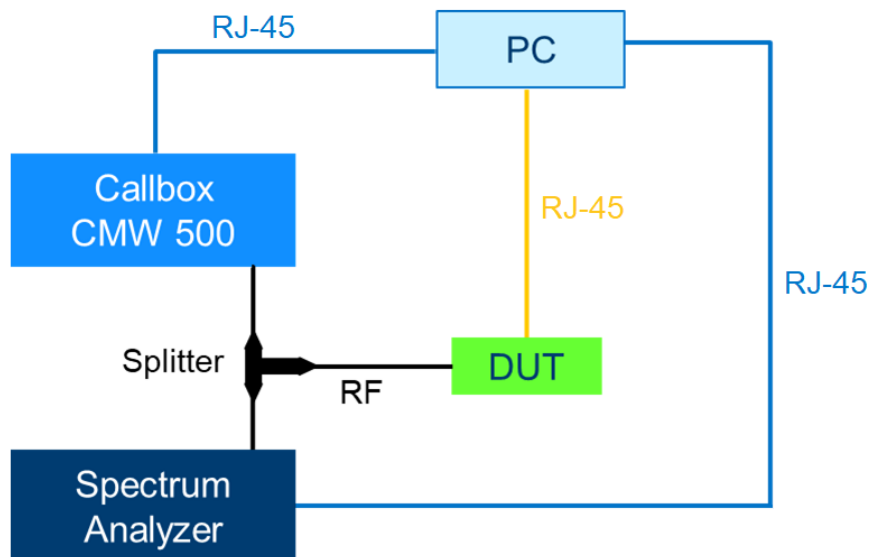

4. Test Result for TAS Validation

4.1. Maximum SAR Tune-up Power per SAR Assessment

Chain A		Chain B	
IEEE 802.11g CH 6	IEEE 802.11a CH 120	IEEE 802.11g CH 6	IEEE 802.11a CH 120
15.0	12.5	15.0	13.5

4.2. TAS Validation for 2.4 GHz Band

Test Case #	Channel	Chain	Channel Bandwidth (MHz)	Measurement Averaging Period (second)	Measurement Time Resolution (millisecond)	Max. Tune-up Power (dBm)	SAR Power in BIOS (dBm)
1	6	A	20	100	0.3333	21.0	15.0
2	6	B	20	100	0.3333	21.0	15.0

Results of test cases in above table are shown in the following plots.

Case #1: 2.4 GHz, CH 6, Chain A, BW 20 MHz, Rate 12 Mbps
Averaging Period: 100 second; T_{max} : 720 second

Max. Tune-up Power (dBm)	SAR Power in BIOS Table (dBm)
21.0	15.0

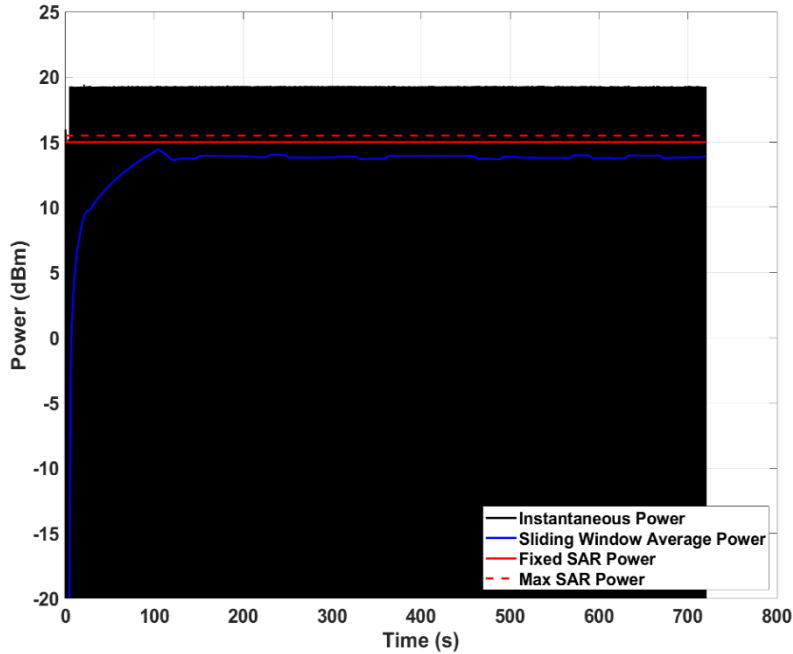

Case #2: 2.4 GHz, CH 6, Chain B, BW 20 MHz, Rate 12 Mbps
Averaging Period: 100 second; T_{max} : 720 second

Max. Tune-up Power (dBm)	SAR Power in BIOS Table (dBm)
21.0	15.0

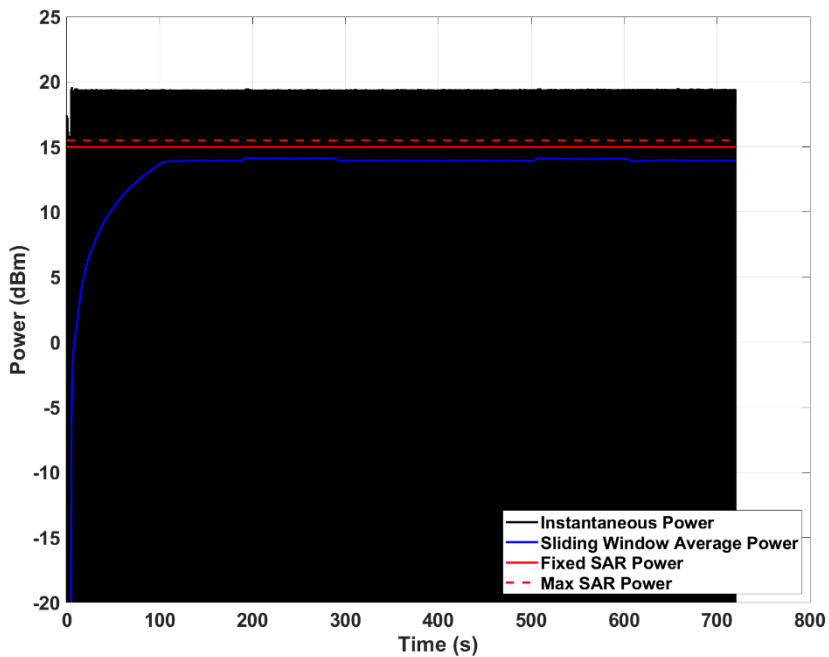

4.3. TAS Validation for 5 GHz Band

Test Case #	Channel	Chain	Channel Bandwidth (MHz)	Measurement Averaging Period (second)	Measurement Time Resolution (millisecond)	Max. Tune-up Power (dBm)	SAR Power in BIOS (dBm)
1	120	A	20	60	0.3333	21.0	12.5
2	120	B	20	60	0.3333	21.0	13.5

Results of test cases in above table are shown in the following plots.

Case #1: 5 GHz, CH 120, Chain A, BW 20 MHz, Rate 12 Mbps
Averaging Period: 60 second; T_{max} : 720 second

Max. Tune-up Power (dBm)	SAR Power in BIOS Table (dBm)
21.0	12.5

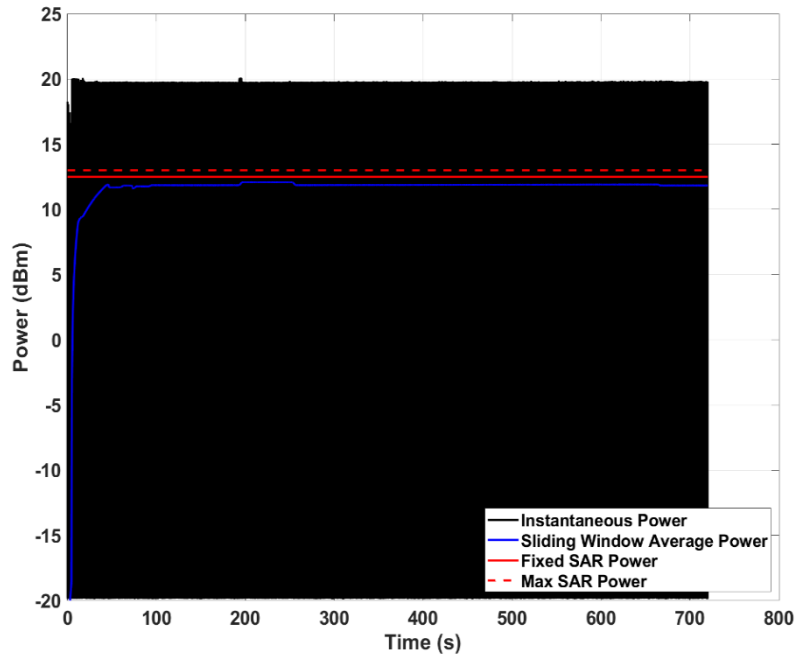

Case #2: 5 GHz, CH 120, Chain B, BW 20 MHz, Rate 12 Mbps
Averaging Period: 60 second; T_{max} : 720 second

Max. Tune-up Power (dBm)	SAR Power in BIOS Table (dBm)
21.0	13.5

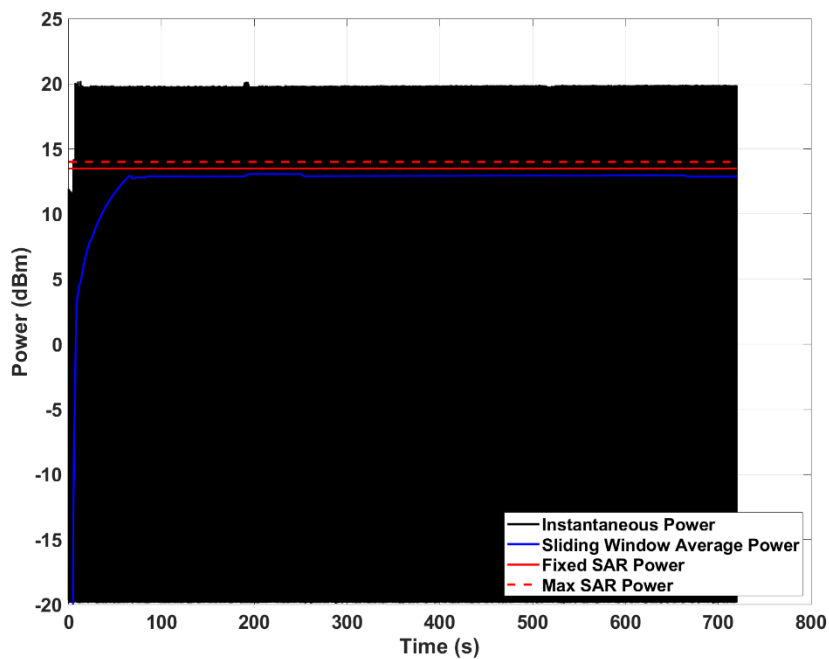

5. Conclusions for Time-Averaging Feature Validation

The Intel's Time-Averaging feature for Wi-Fi employed in this device has been validated through the conducted power measurement (as demonstrated in Chapter 4).

With the combination of the **SAR Evaluation Report (Test Under Static Transmission Scenario)** for FCC equipment authorization, and this **TAS Algorithm Validation Report** for time-averaging feature validation, it can be concluded that the time-averaged RF exposure for this device is compliant with the FCC limits in all transmission scenarios for all the supported radios.

6. Equipment List

Manufacturer	Equipment	Model	Serial No.	Cal. Date	Cal. Interval
R&S	Wireless Communication Test Set	CMW500	170768	Nov. 30, 2022	2 year
R&S	Spectrum Analyzer	FSV3044	101255	Nov. 30, 2023	1 year

Test Engineer : Joanna Chen

***** End of Report *****