

TEST REPORT

EUT Description	WLAN and BT, 2x2 PCIe M.2 2230 adapter card
Brand Name	Intel® Wi-Fi 6 AX201
Model Name	AX201NGW
FCC ID	PD9AX201NG
Date of Test Start/End	2021-06-24 /2021-08-26
Features	802.11ax, Dual Band, 2x2 Wi-Fi + Bluetooth® 5.2 (see section 5)

Applicant	Intel Mobile Communications
Address	100 Center Point Circle, Suite 200 Columbia, South Carolina 29210 USA
Contact Person	Steven Hackett
Telephone/Fax/ Email	steven.c.hackett@intel.com

Reference Standards	FCC CFR Title 47 Part 15 E (see section 1)
---------------------	---

Test Report identification	210209-01.TR30
Revision Control	Rev. 01 This test report revision replaces any previous test report revision (see section 8)

The test results relate only to the samples tested.
Reference to accreditation shall be used only by full reproduction of test report.

_____ Issued by _____ Reviewed by _____

Cedric REQUIN
(Test Engineer Lead)

Zayd OUACHICHA
(Technical Manager)

Table of Contents

1. Standards, reference documents and applicable test methods	3
2. General conditions, competences and guarantees	3
3. Environmental Conditions	3
4. Test samples	4
5. EUT Features	4
6. Remarks and comments	5
7. Test Verdicts summary	5
7.1. 802.11 a/n/ac/ax – U-NII- 4	5
8. Document Revision History	5
A.1 MEASUREMENT SYSTEM	6
A.2 TEST EQUIPMENT LIST	8
A.3 MEASUREMENT UNCERTAINTY EVALUATION	10
B.1 TEST CONDITIONS	11
B.2 TEST RESULTS TABLES	12
B.2.1 6dB & 99% BANDWIDTH	12
B.2.2 MAXIMUM OUTPUT POWER & MAXIMUM POWER SPECTRAL DENSITY	14
B.2.3 UNDESIRABLE EMISSION LIMITS : OUT OF BAND (CONDUCTED)	20
B.2.4 RADIATED SPURIOUS EMISSION	21
B.3 TEST RESULTS SCREENSHOT	39
B.3.1 6dB BANDWIDTH	39
B.3.2 99% BANDWIDTH	43
B.3.3 MAXIMUM OUTPUT POWER	48
B.3.4 MAXIMUM POWER SPECTRAL DENSITY (PSD)	52
B.3.5 UNDESIRABLE EMISSION LIMITS : OUT OF BAND (CONDUCTED)	57
C.1 TEST SETUP	78
C.2 TEST SAMPLE	80

1. Standards, reference documents and applicable test methods

FCC	<ol style="list-style-type: none"> 1. FCC Title 47 CFR part 15 – Subpart E – Unlicensed National Information Infrastructure Devices. 2021-05-03 online Edition 2. FCC Title 47 CFR part 15 – Subpart C – §15.209 Radiated emission limits; general requirements. 2019-10-01 Edition 3. FCC OET KDB 662911 D01 v02r01 - Emissions Testing of Transmitters with Multiple Outputs in the Same Band. 4. FCC OET KDB 789033 D02 v02r01 - Guidelines for compliance testing of unlicensed national information infrastructure (U-NII) devices part 15, subpart E 5. ANSI C63.10-2013 American National Standard of Procedures for Compliance Testing of Unlicensed Wireless Devices. 6. FCC OET KDB 291074 D01 v01 - General Requirements 7. FCC OET KDB 291074 D02 v01 - EMC Measurement 8. FCC OET KDB 291074 D03 v01 - QA General Questions and Answers
-----	--

2. General conditions, competences and guarantees

- ✓ Tests performed under FCC standards identified in section 1 are covered by A2LA accreditation.
- ✓ Intel Corporation SAS Wireless RF Lab (Intel WRF Lab) is an ISO/IEC 17025:2017 laboratory accredited by the American Association for Laboratory Accreditation (A2LA) with the certificate number 3478.01.
- ✓ Intel Corporation SAS Wireless RF Lab (Intel WRF Lab) is an Accredited Test Firm recognized by the FCC, with Designation Number FR0011.
- ✓ Intel WRF Lab only provides testing services and is committed to providing reliable, unbiased test results and interpretations.
- ✓ Intel WRF Lab is liable to the client for the maintenance of the confidentiality of all information related to the item under test and the results of the test.
- ✓ Intel WRF Lab has developed calibration and proficiency programs for its measurement equipment to ensure correlated and reliable results to its customers.
- ✓ This report is only referred to the item that has undergone the test.
- ✓ This report does not imply an approval of the product by the Certification Bodies or competent Authorities.

3. Environmental Conditions

- ✓ At the site where the measurements were performed the following limits were not exceeded during the tests:

Temperature	24.2%±1.8C
Humidity	49.6%±4.4%

4. Test samples

Sample	Control #	Description	Model	Serial #	Date of receipt	Note
#01	201210-02.S16	RF Module	AX201NGW	WFM:3413E8E4FDCC	18-01-2021	RF Conducted
	180717-03.S16	EXTENDER	PCB00651	6510818-127	21-08-2018	
	170000-01.S02	Laptop	Latitude E5470	21HTPF2	28-03-2017	
#02	201210-02.S16	RF Module	AX201NGW	WFM:3413E8E4FDCC	2021-01-18	Used for 1 GHz-40 GHz Radiated Spurious Emission tests
	200611-03.S26	Extender	ADEXELEC	-	2020-07-01	
	200928-02.S11	Adaptor	M2 Adaptor	6961919-172	2020-10-27	
	170000-01.S01	Laptop	Latitude E5470	DBPLMC2	2017-03-28	
	200611-03.S28	Main Antenna	SkyCross	-	2020-07-01	
	200611-03.S29	Aux Antenna	SkyCross	-	2020-07-01	
#03	201210-02.S16	RF Module	AX201NGW	WFM:3413E8E4FDCC	2021-01-18	Used for 30 MHz-1 GHz Radiated Spurious Emission tests
	200504-04.S07	Laptop	Latitude 5401	BVHLK13	2020-06-02	
	200504-04.S07	Extender	ADEXELEC	-	2020-06-02	
	200928-02.S11	Adaptor	M2 Adaptor	6961919-172	2020-10-27	
	200611-03.S28	Main Antenna	SkyCross	-	2020-07-01	
	200611-03.S29	Aux Antenna	SkyCross	-	2020-07-01	

5. EUT Features

The herein information is provided by the customer

Brand Name	Intel® Wi-Fi 6 AX201		
Model Name	AX201NGW		
Software Version	DRTU Version: 22.21040.0.0-OEM.DRTU.11758		
Driver Version	99.0.62.2		
Prototype / Production	Production		
Supported Radios	802.11b/g/n/ax	2.4 GHz (2400.0 – 2483.5 MHz)	
	802.11a/n/ac/ax	5.2 GHz (5150.0 – 5350.0 MHz) 5.6 GHz (5470.0 – 5725.0 MHz) 5.8 GHz (5725.0 – 5895.0 MHz) 5.9 GHz (5850.0 – 5895.0 MHz)	
	Bluetooth 5.2	2.4 GHz (2400.0 – 2483.5 MHz)	
Antenna Information	Transmitter	Main (chain A)	Aux (chain B)
	Manufacturer	SkyCross	Skycross
	Antenna type	PIFA antenna	PIFA antenna
	Part number	N/A	N/A
	Declared antenna gain (dBi)	+5	+5

6. Remarks and comments

1. No deviations were made from the test methods listed in section 1 of this report
2. Only the worst-case plot per 802.11 mode and test case measurements have been reported excepted for band edge measurements where all plots are reported
3. Tests have been performed with the KDB draft. No deviation between the KDB draft and the KDB has been identified.

7. Test Verdicts summary

The statement of conformity to applicable standards in the table below are based on the measured values, without taking into account the measurement uncertainties.

7.1. 802.11 a/n/ac/ax – U-NII- 4

FCC part	Test name	Verdict
15.407 (e)	6dB Bandwidth	P
15.407 (a) (3)	Maximum output power	P
15.407 (a) (3)	Power spectral density	P
15.407 (b) (5)	Undesirable emissions limits: out of band (conducted)	P
15.407 (b) (5) 15.209	Undesirable emissions limits: Spurious emissions (radiated)	P

P: Pass
 F: Fail
 NM: Not Measured
 NA: Not Applicable

8. Document Revision History

Revision #	Modified by	Revision Details
Rev. 00	C.Requin	First Issue
Rev. 01	C.Requin	PSD500kHz plots added

Annex A. Test & System Description

A.1 Measurement System

Measurements were performed using the following setups, made in accordance to the general provisions of ANSI C63.10-2013

The DUT was installed in a test fixture and this test fixture is connected to a laptop computer and AC/DC power adapter. The laptop computer was used to configure the EUT to continuously transmit at a specified output power using all different modes and modulation schemes, using the Intel proprietary tool DRTU.

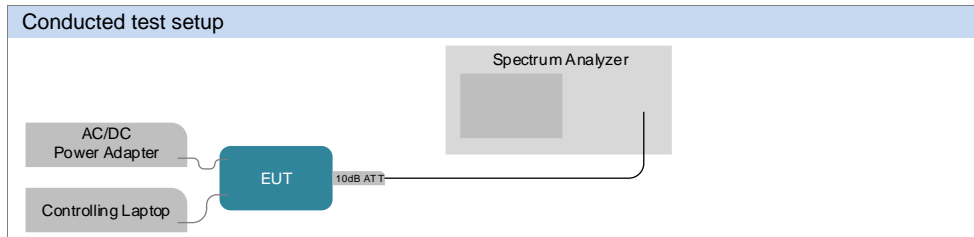

Radiated test setup

Radiated Setup 30 MHz - 1 GHz (Transmitter tests)

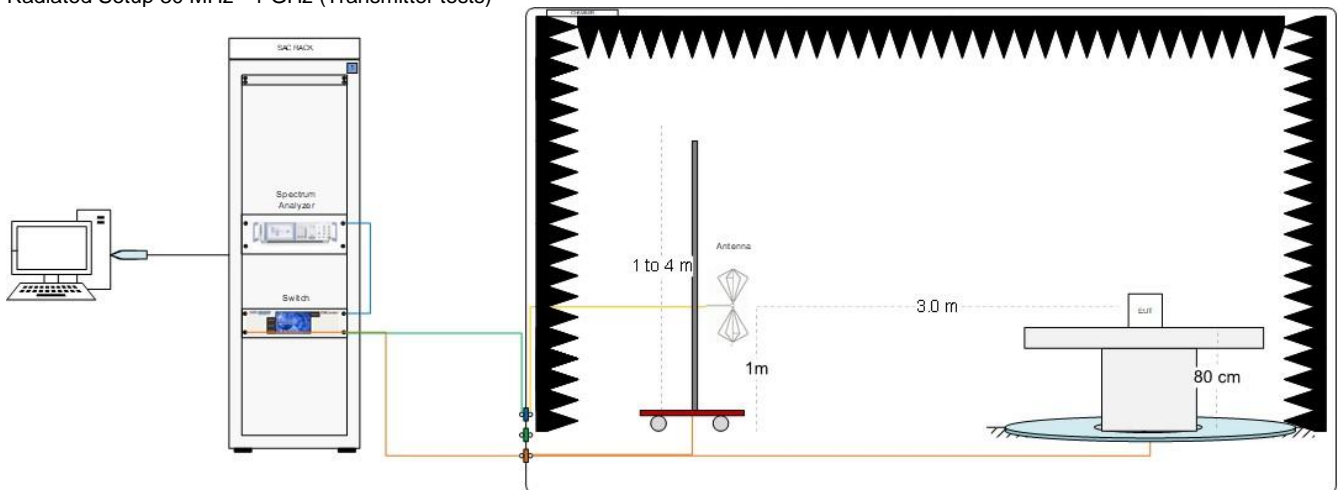

Radiated Setup 1 GHz - 6.4 GHz (Transmitter tests)

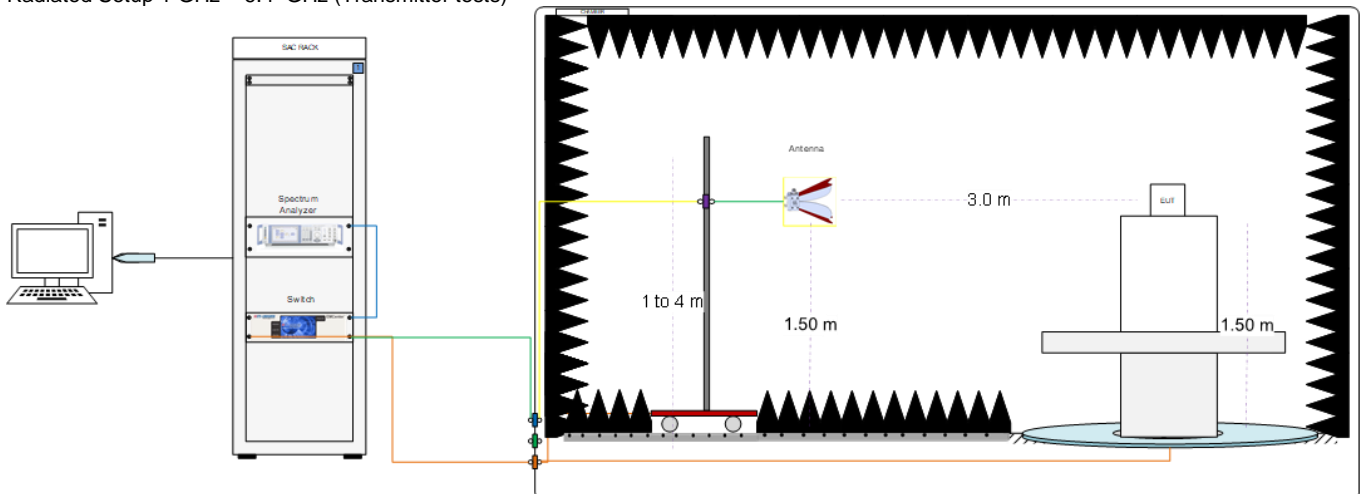

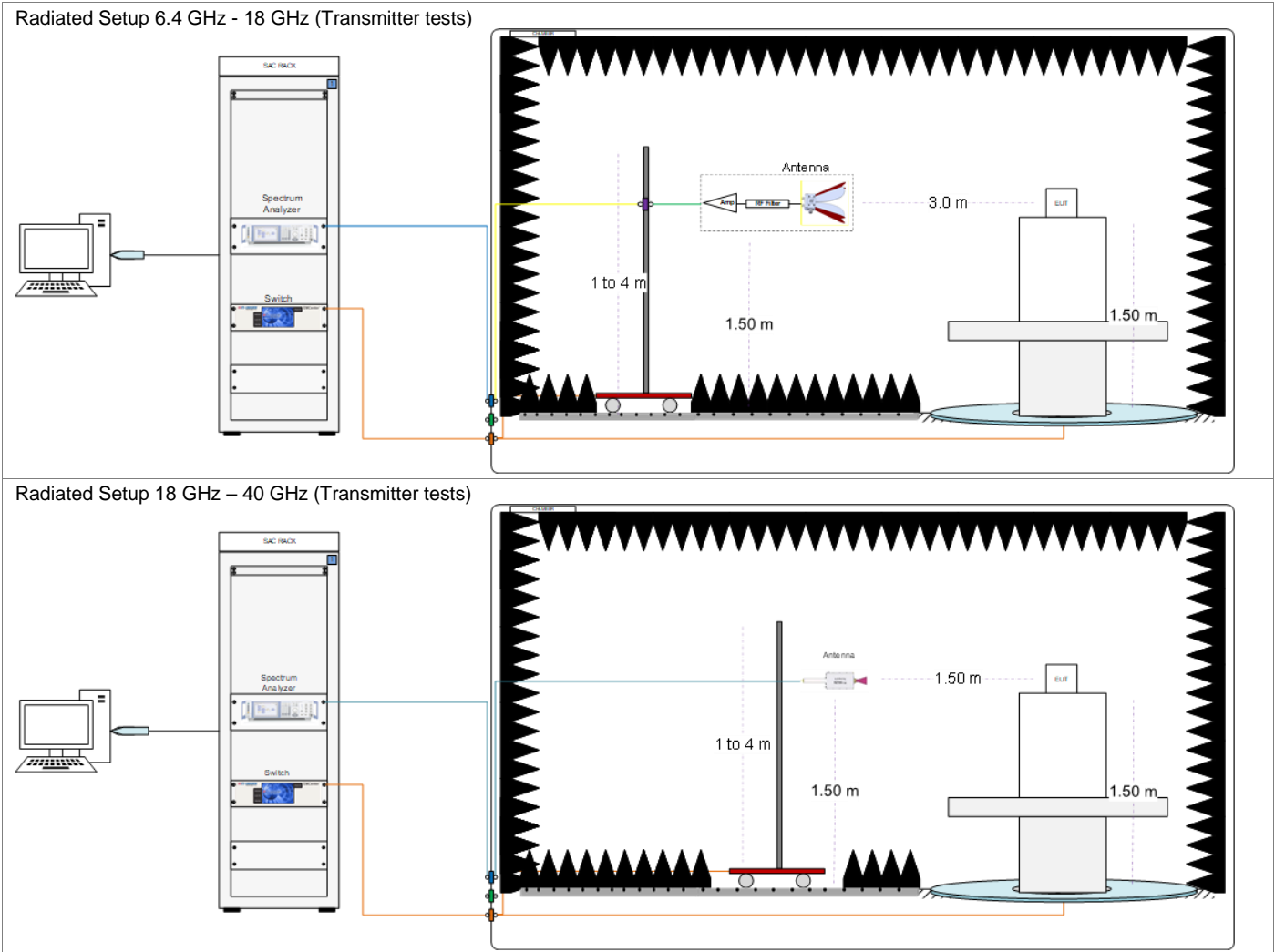

Sample Calculation

The spurious received voltage V (dB μ V) in the spectrum Analyzer is converted to Electric field strength using the transducer factor F corresponding to the Rx path Loss:

$$F \text{ (dB/m)} = \text{Rx Antenna Factor (dB/m)} + \text{Cable losses (dB)} - \text{Amplifiers Gain (dBi)}$$

$$E \text{ (dB}\mu\text{V/m)} = V \text{ (dB}\mu\text{V)} + F \text{ (dB/m)}$$

For field strength measurements made at other than the distance at which the applicable limit is specified, the field strength of the emission at the distance specified by the limit is deduced as follows:

$$E_{\text{SpecLimit}} = E_{\text{Meas}} + 20 \cdot \log(D_{\text{Meas}}/D_{\text{SpecLimit}})$$

where

- $E_{\text{SpecLimit}}$ is the field strength of the emission at the distance specified by the limit, in dB μ V/m
- E_{Meas} is the field strength of the emission at the measurement distance, in dB μ V/m
- D_{Meas} is the measurement distance, in m
- $D_{\text{SpecLimit}}$ is the distance specified by the limit, in m

A.2 Test Equipment List

Conducted setup

ID#	Device	Type/Model	Serial #	Manufacturer	Cal. Date	Cal. Due Date
273-000	Spectrum Analyzer	FSV30	103309	Rohde & Schwarz	2019-09-02	2021-09-02
017-003	Power supply	E3640A	MY40006885	Agilent	NA	NA
018-003	RF cable 50cm	PE360-50CM	N/A	PASTERNAK	2021-02-21	2022-02-21
018-001	10dB Attenuator + MH4	N/A	N/A	N/A	2021-03-09	2022-02-23
408-000	Temp & Humidity Logger	RA12E-TH1-RAS	RA12-E21FC8	AVTECH	2021-06-26	2023-06-03
413-000	Measurement SW v1.5.4.2	Octopi	N/A	Step AT	N/A	N/A

N/A: Not applicable

Radiated Setup #1

ID#	Device	Type/Model	Serial #	Manufacturer	Cal. Date	Cal. Due Date
006-000	Anechoic Chamber	FACT3	5720	ETS-Lindgren	2020-07-06	2022-07-06
006-001	Turn Table	ETS	-	ETS-Lindgren	N/A	N/A
006-002	Switch & Positioning systems	EMC Center	00159757	ETS-Lindgren	N/A	N/A
006-008	Measurement SW, v10.40.10	EMC32	100623	Rohde & Schwarz	N/A	N/A
006-011	Boresight antenna mast	BAM 4.0-P	P/278/2890.01	Maturo	N/A	N/A
006-019	Biconical antenna 30 MHz – 1 GHz	UBAA9115 + BBVU9135 + DGA9552N	0286 + CH 9044	Schwarzbeck	2019-11-22	2021-11-22
147-000	Spectrum analyzer	FSW43	101847	Rohde & Schwarz	2020-11-02	2022-11-02
*006-020	Horn antenna 3117	3117	00157734	ETS-Lindgren	2019-08-12	2021-08-12
056-000	Horn Antenna 3117 + Amplifier + HPF6.4	3117	00157736	ETS-Lindgren	2020-04-01	2022-04-01
*007-008	Double Horn Ridged antenna	3116C-PA	00169308bis + 00196308	ETS-Lindgren	2019-07-24	2021-07-24
*006-039	Cable 2.5m - 30MHz to 18GHz	0500990992500KE	19.23.395	Radiall	2021-02-23	2021-08-23
*006-030	Cable 1.2m – 18 to 40 GHz	UFA147A-0-0480-200200	MFR 64639223720-003	Micro-coax	2021-02-14	2021-08-14
*006-034	Cable 1m - 1GHz to 18GHz	UFA147A	-	Utilflex	2021-02-18	2021-08-18
*006-036	Cable 1m – 30 MHz - 18GHz	UFB311A-0-0590-50U50U	MFR 64639 223230-001	Micro-coax	2021-02-23	2021-08-23
*006-052	RF Cable 7.5m	0501051057000GX	19.35.850	Radiall	2021-02-23	2021-08-23
*006-038	Cable 7m - 18GHz to 40GHz	R286304009	-	Radiall	2021-02-14	2021-08-14
*006-051	RF Cable 1.0m	CBL-1.5M-SMSM+	202879	Mini-Circuits	2021-02-23	2021-08-23
*363-000	Temperature & Humidity logger	RA12E-TH1-RAS	RA12-D0EB1A	Avtech	2019-07-03	2021-07-03
365-000	Temperature & Humidity logger	RA12E-TH1-RAS	00-80-A3-E1-6E-55	Avtech	2021-03-08	2023-03-08

N/A: Not Applicable

*Items not used during out of calibration period

Radiated Setup #2

ID#	Device	Type/Model	Serial #	Manufacturer	Cal. Date	Cal. Due Date
007-000	Anechoic chamber	RFD-FA-100	5996	ETS Lindgren	2020-07-06	2022-07-06
007-002	Turntable	-	-	ETS Lindgren	N/A	N/A
007-003	Antenna Tower	2171B-3.0M	00150123	ETS Lindgren	N/A	N/A
007-006	Switch & Positioner	EMCenter	00151232	ETS Lindgren	N/A	N/A
007-005	Measurement SW, V11.20.00	EMC32	100401	Rohde & Schwarz	N/A	N/A
127-000	Spectrum Analyzer	FSV40	101358	Rohde & Schwarz	2021-01-15	2023-01-15
007-007	Double Ridge Horn (1-18GHz)	3117	00152266	ETS Lindgren	2020-03-18	2022-03-18
056-000	Horn Antenna 3117 + Amplifier + HPF6.4	3117	00157736	ETS-Lindgren	2020-04-01	2022-04-01
*007-008	Double Horn Ridged antenna	3116C-PA	00169308bis + 00196308	ETS-Lindgren	2019-07-24	2021-07-24
*007-022	RF Cable 1-18GHz, 1.5m	0501050991200GX	19.23.493	Radiall	2021-02-14	2021-08-14
*007-020	RF Cable 1-18GHz, 1.2 m	2301761761200PJ	12.22.1104	Radiall	2021-02-14	2021-08-14
*007-011	RF Cable 1-18GHz - 6.5m	140-8500-11-51	001	Spectrum	2021-02-14	2021-08-14
*007-015	RF Cable 1GHz-18GHz 1.5m	-	-	Spirent	2021-02-15	2021-08-15
*007-014	RF Cable 18-40 GHz 6m	R286304009	1747364	Radiall	2021-02-14	2021-08-14
*007-023	RF Cable 1m DC-40GHz	PE360-100CM	-	Pasternack	2021-02-16	2021-08-16
*007-018	RF Cable 1-9.5GHz 1.2m	0500990991200KE	-	Radiall	2021-02-15	2021-08-15
*362-000	Temp & Humidity Logger	RA12E-TH1-RAS	RA12-D4F316	Avtech	2019-07-05	2021-07-05
145-000	Temp & Humidity Logger	RA12E-TH1-RAS	RA12-B89BE3	Avtech	2020-01-22	2022-01-22

N/A: Not Applicable

*Items not used during out of calibration period

Shared Radiated Equipment

ID#	Device	Type/Model	Serial #	Manufacturer	Cal. Date	Cal. Due Date
412-000	DRTU Power finder V2.0	-	-	Intel	NA	NA
022-000	Power Sensor	NRP-Z81	104385	Rohde & Schwarz	2020-04-08	2022-04-08
061-000	Power Sensor	NRP-Z81	104386	Rohde & Schwarz	2020-04-08	2022-04-08
140-000	Power Sensor	NRP-Z81	104382	Rohde & Schwarz	2020-04-08	2022-04-08

A.3 Measurement Uncertainty Evaluation

The system uncertainty evaluation is shown in the table below with a coverage factor of $k = 2$ to indicate a 95% level of confidence:

Measurement type	Uncertainty	Unit
Timing	± 0.12	%
Power Spectral density	± 1.47	dB
Occupied bandwidth	± 2.07	%
Conducted Power	± 1.03	dB
Conducted Out of band Emission <7 GHz	± 1.67	dB
Radiated tests <1GHz	± 5.99	dB
Radiated tests 1GHz – 40 GHz	± 5.85	dB

Annex B. Test Results U-NII-4

The herein test results were performed by:

Test case measurement	Test Personnel
6dB and 99% Bandwidth	C.Requin Y Haddad
Maximum output power & Maximum PSD	C.Requin
Undesirable emission limits: out of band	C.Requin Y Haddad
Radiated spurious emissions	A.Lounes, N.Bui

B.1 Test Conditions

For 802.11a mode the EUT can transmit at both CHAIN A and CHAIN B RF outputs individually, but not simultaneously.

For 802.11n20 & 802.11ax20 (20 MHz channel bandwidth), 802.11n40 & 802.11ax40 (40MHz channel bandwidth), 802.11ac80 & 802.11ax80 (80MHz channel bandwidth) and 802.11ac160 & 802.11ax160 (160MHz channel bandwidth) modes the EUT can transmit at both CHAIN A and CHAIN B RF outputs individually, and also simultaneously.

The following data rates were selected based on preliminary testing that identified those rates as the worst cases for output power and spurious levels at the band edges:

Transmission	Mode	Bandwidth (MHz)	Worst Case Data Rate
SISO	802.11a	20	6Mbps
	802.11n	20	HT0
		40	HT0
	802.11ac	80/160	VHT0
	802.11ax	20/40/80/160	HE0
MIMO	802.11n	20/40	HT8
	802.11ac	80/160	VHT0
	802.11ax	20/40/80/160	HE0

B.2 Test Results Tables

B.2.1 6dB & 99% Bandwidth

Test limits

FCC part	Limits
15.407 (e)	For equipment operating in the band 5725-5895 MHz, the minimum 6 dB bandwidth shall be at least 500 kHz.

Test procedure

The conducted setup shown in section *Test & System Description* was used to measure the 6dB & 99% Bandwidth. The antenna terminal of the EUT is connected to the spectrum analyzer through an attenuator, and the spectrum analyzer reading is compensated to include the RF path loss.

Results tables

Mode	Rate	Antenna	Channel	Freq [MHz]	6dB BW [MHz]	99% BW [MHz]			
802.11a	6Mbps	SISO A	169	5845	15.10	16.72			
			173	5865	15.01	16.72			
			177	5885	15.10	16.72			
		SISO B	169	5845	15.29	16.72			
			173	5865	15.08	16.72			
			177	5885	15.10	16.76			
802.11n20	HT0	SISO A	169	5845	14.99	17.88			
			173	5865	15.00	17.88			
			177	5885	16.50	17.92			
		SISO B	169	5845	15.01	17.88			
			173	5865	15.41	17.92			
			177	5885	15.07	18.00			
	HT8	MIMO A	169	5845	15.03	17.80			
			173	5865	15.11	17.72			
			177	5885	15.75	17.76			
		MIMO B	169	5845	15.65	17.76			
			173	5865	15.28	17.76			
			177	5885	16.90	17.76			
802.11n40	HT0	SISO A	167	5835	35.05	38.24			
			175	5875	35.01	37.28			
		SISO B	167	5835	33.77	38.16			
			175	5875	35.01	39.84			
	HT8	MIMO A	167	5835	33.75	36.40			
			175	5875	33.79	36.40			
		MIMO B	167	5835	35.07	36.40			
			175	5875	35.09	36.32			
			802.11ac80	VHT0	SISO A	171	5855	70.13	75.20
					SISO B			72.75	75.52
MIMO A	72.64	75.36							
MIMO B	72.64	75.52							
802.11ac160	VHT0	SISO A	163	5815	132.63	153.60			
		SISO B			118.93	153.60			
		MIMO A			131.43	153.28			
		MIMO B			141.43	153.28			

Max Value

Mode	Rate	Antenna	Channel	Freq [MHz]	6dB BW [MHz]	99% BW [MHz]
802.11ax20	HE0	SISO A	169	5845	16.08	19.04
			173	5865	16.61	18.96
			177	5885	13.38	18.96
		SISO B	169	5845	16.70	19.04
			173	5865	15.89	19.08
			177	5885	15.09	19.00
		MIMO A	169	5845	16.97	19.00
			173	5865	15.75	18.88
			177	5885	15.38	18.88
		MIMO B	169	5845	13.89	18.96
			173	5865	15.76	18.96
			177	5885	15.44	18.92
802.11ax40	HE0	SISO A	167	5835	35.24	38.24
			175	5875	35.86	37.92
		SISO B	167	5835	35.06	38.24
			175	5875	35.07	38.16
		MIMO A	167	5835	35.44	37.92
			175	5875	33.72	37.84
		MIMO B	167	5835	35.03	37.92
			175	5875	35.07	37.76
802.11ax80	HE0	SISO A	171	5855	72.69	76.64
		SISO B			73.92	76.96
		MIMO A			73.81	76.80
		MIMO B			73.87	76.96
802.11ax160	HE0	SISO A	163	5815	152.63	154.88
		SISO B			148.88	154.88
		MIMO A			152.63	154.88
		MIMO B			150.13	154.56

Max Value

See Section B.3.1, B.3.2 for the screenshot results.

B.2.2 Maximum output power & Maximum power spectral Density

Test limits

FCC part	Limits
15.407 (a) (3) (iii)	For client devices operating under the control of an indoor access point in the 5.850-5.895 GHz band, the maximum power spectral density must not exceed 14 dBm e.i.r.p. in any 1-megahertz band, and the maximum e.i.r.p. over the frequency band of operation must not exceed 30 dBm. Client devices operating on a channel that spans the 5.725-5.850 GHz and 5.850-5.895 GHz bands must not exceed an e.i.r.p. of 30 dBm.
15.407 (a) (12)	Power spectral density measurement: The maximum power spectral density is measured as a conducted emission by direct connection of a calibrated test instrument to the equipment under test. Measurements in the 5.725-5.895 GHz band are made over a reference bandwidth of 500 kHz or the 26 dB emission bandwidth of the device, whichever is less.

Test procedure

The Maximum Conducted Output Power was measured using the channel integration method over the entire 99% occupied bandwidth according to section E) 2) d) (Method SA-2) of KDB 789033

The maximum power spectral density (PSD) was measured using the method according to section F) of KDB 789033.

In the measure-and-sum approach for MIMO mode, the conducted emission level (e.g., transmit power or power in specified bandwidth) is measured at each antenna port. The measured results at the various antenna ports are then summed mathematically in linear power units to determine the total emission level from the device.

The EIRP power (dBm) is calculated by adding the declared maximum antenna gain to the measured conducted power.

The conducted setup shown in section *Test & System Description* was used to measure the maximum conducted output power and power spectral density. The antenna terminal of the EUT is connected to the spectrum analyser through an attenuator, and the spectrum analyzer reading is compensated to include the RF path loss.

Results tables
Duty cycle

Mode	Rate	Antenna	Duty Cycle [%]
802.11a	6Mbps	SISO A	97.76
		SISO B	97.76
802.11n20	HT0	SISO A	98.50
		SISO B	98.50
	HT8	MIMO A	97.90
		MIMO B	97.90
802.11ax20	HE0	SISO A	98.00
		SISO B	98.00
		MIMO A	98.00
		MIMO B	98.00
802.11n40	HT0	SISO A	98.00
		SISO B	98.00
	HT8	MIMO A	98.00
		MIMO B	98.00
802.11ax40	HE0	SISO A	98.00
		SISO B	98.00
		MIMO A	98.70
		MIMO B	98.70
802.11ac80	VHT0	SISO A	98.00
		SISO B	98.00
		MIMO A	98.00
		MIMO B	98.00
802.11ax80	HE0	SISO A	98.00
		SISO B	98.00
		MIMO A	98.00
		MIMO B	98.00
802.11ac160	VTH0	SISO A	98.00
		SISO B	98.00
		MIMO A	97.90
		MIMO B	97.90
802.11ax160	HE0	SISO A	98.40
		SISO B	98.40
		MIMO A	97.00
		MIMO B	97.00

Maximum output power – U-NII-4 Channels

Mode	Rate	Channel	Freq [MHz]	Antenna	Average Conducted Ouput Power [dBm]	Avg Max* Conducted Ouput Power [dBm]	Avg Max*. EIRP [dBm]	Avg Max* Conducted Ouput Power [mW]
802.11a	6Mbps	169	5845	SISO A	19.73	19.83	24.83	96.13
				SISO B	19.54	19.64	24.64	92.01
		173	5865	SISO A	19.63	19.73	24.73	93.94
				SISO B	19.69	19.79	24.79	95.24
		177	5885	SISO A	19.73	19.83	24.83	96.13
SISO B	19.57			19.67	24.67	92.65		
802.11n20	HT0	169	5845	SISO A	19.87	19.87	24.87	97.05
				SISO B	19.74	19.74	24.74	94.19
		173	5865	SISO A	19.77	19.77	24.77	94.84
				SISO B	19.90	19.90	24.90	97.72
		177	5885	SISO A	19.84	19.84	24.84	96.38
				SISO B	19.77	19.77	24.77	94.84
	HT8	169	5845	MIMO A	16.78	16.87	21.87	48.67
				MIMO B	16.80	16.89	21.89	48.89
				Combined A+B	19.80	19.89	24.89	97.55
		173	5865	MIMO A	16.67	16.76	21.76	47.45
				MIMO B	17.06	17.15	22.15	51.91
				Combined A+B	19.88	19.97	24.97	99.36
		177	5885	MIMO A	16.82	16.91	21.91	49.12
				MIMO B	16.77	16.86	21.86	48.55
				Combined A+B	19.81	19.90	24.90	97.77
802.11n40	HT0	167	5835	SISO A	21.21	21.21	26.21	132.13
				SISO B	21.07	21.07	26.07	127.94
		175	5875	SISO A	20.70	20.70	25.70	117.49
				SISO B	21.05	21.05	26.05	127.35
	HT8	167	5835	MIMO A	20.12	20.12	25.12	102.80
				MIMO B	20.09	20.09	25.09	102.09
				Combined A+B	23.12	23.12	28.12	205.12
		175	5875	MIMO A	18.91	18.91	23.91	77.80
				MIMO B	20.00	20.00	25.00	100.00
				Combined A+B	22.50	22.50	27.50	177.83
802.11ac80	VHT0	171	5855	SISO A	19.02	19.02	24.02	79.80
				SISO B	18.84	18.84	23.84	76.56
				MIMO A	17.54	17.54	22.54	56.75
				MIMO B	17.60	17.60	22.60	57.54
				Combined A+B	20.58	20.58	25.58	114.29
802.11ac160	VHT0	163	5815	SISO A	14.17	14.17	19.17	26.12
				SISO B	13.35	13.35	18.35	21.63
				MIMO A	13.59	13.68	18.68	23.35
				MIMO B	12.33	12.42	17.42	17.47
				Combined A+B	16.02	16.11	21.11	40.85

* Maximum values are the duty cycle compensated values calculated from the average (measured)

Max Value

Min Value

Mode	Rate	Channel	Freq [MHz]	Antenna	Average Conducted Ouput Power [dBm]	Avg Max* Conducted Ouput Power [dBm]	Avg Max*. EIRP [dBm]	Avg Max* Conducted Ouput Power [mW]
802.11ax20	HE0	169	5845	SISO A	19.93	19.93	24.93	98.40
				SISO B	20.03	20.03	25.03	100.69
				MIMO A	16.83	16.83	21.83	48.19
				MIMO B	16.80	16.80	21.80	47.86
				Combined A+B	19.83	19.83	24.83	96.16
		173	5865	SISO A	20.12	20.12	25.12	102.80
				SISO B	19.95	19.95	24.95	98.86
				MIMO A	17.07	17.07	22.07	50.93
				MIMO B	16.99	16.99	21.99	50.00
		177	5885	Combined A+B	20.04	20.04	25.04	100.93
				SISO A	19.92	19.92	24.92	98.17
				SISO B	20.09	20.09	25.09	102.09
802.11ax40	HE0	167	5835	MIMO A	16.87	16.87	21.87	48.64
				MIMO B	16.91	16.91	21.91	49.09
				Combined A+B	19.90	19.90	24.90	97.72
				SISO A	21.13	21.13	26.13	129.72
				SISO B	21.00	21.00	26.00	125.89
		175	5875	MIMO A	20.38	20.38	25.38	109.14
				MIMO B	20.40	20.40	25.40	109.65
				Combined A+B	23.40	23.40	28.40	218.78
				SISO A	20.71	20.71	25.71	117.76
		175	5875	SISO B	20.86	20.86	25.86	121.90
				MIMO A	19.27	19.27	24.27	84.53
				MIMO B	20.29	20.29	25.29	106.91
175	5875	Combined A+B	22.82	22.82	27.82	191.43		
		SISO A	18.86	18.86	23.86	76.91		
		SISO B	18.66	18.66	23.66	73.45		
		MIMO A	17.23	17.23	22.23	52.84		
802.1ax80	HE0	171	5855	MIMO B	17.30	17.30	22.30	53.70
				Combined A+B	20.28	20.28	25.28	106.66
				SISO A	14.75	14.75	19.75	29.85
				SISO B	13.33	13.33	18.33	21.53
802.11ax160	HE0	163	5815	MIMO A	13.53	13.66	18.66	23.24
				MIMO B	12.54	12.67	17.67	18.50
				Combined A+B	16.07	16.20	21.20	41.71
				SISO A	14.75	14.75	19.75	29.85
				SISO B	13.33	13.33	18.33	21.53

* Maximum values are the duty cycle compensated values calculated from the average (measured)

Max Value

Min Value

See Section B.3.3 for the screenshot results

Maximum Power Spectral Density (PSD) – U-NII-4 channels

Mode	Rate	Channel	Freq [MHz]	Antenna	Average conducted PSD [dBm/500kHz]	Max.* conducted PSD [dBm/500kHz]	Max.* conducted PSD [dBm/MHz]	EIRP PSD* [dBm/MHz]	
802.11a	6Mbps	169	5845	SISO A	5.80	5.90	8.91	13.91	
				SISO B	5.59	5.69	8.70	13.70	
		173	5865	SISO A	5.74	5.84	8.85	13.85	
				SISO B	5.76	5.86	8.87	13.87	
		177	5885	SISO A	5.82	5.92	8.93	13.93	
				SISO B	5.69	5.79	8.80	13.80	
802.11n20	HT0	169	5845	SISO A	5.77	5.77	8.78	13.78	
				SISO B	5.64	5.64	8.65	13.65	
		173	5865	SISO A	5.75	5.75	8.76	13.76	
				SISO B	5.80	5.80	8.81	13.81	
		177	5885	SISO A	5.81	5.81	8.82	13.82	
				SISO B	5.70	5.70	8.71	13.71	
	HT8	169	5845	MIMO A	2.73	2.82	5.83	10.83	
				MIMO B	2.76	2.85	5.86	10.86	
				Combined A+B	5.76	5.85	8.86	13.86	
		173	5865	MIMO A	2.58	2.67	5.68	10.68	
				MIMO B	2.87	2.96	5.97	10.97	
				Combined A+B	5.74	5.83	8.84	13.84	
	177	5885	MIMO A	2.66	2.75	5.76	10.76		
			MIMO B	2.68	2.77	5.78	10.78		
			Combined A+B	5.68	5.77	8.78	13.78		
	802.11n40	HT0	167	5835	SISO A	3.71	3.71	6.72	11.72
					SISO B	3.57	3.57	6.58	11.58
			175	5875	SISO A	3.19	3.19	6.20	11.20
SISO B					3.54	3.54	6.55	11.55	
HT8		167	5835	MIMO A	2.64	2.64	5.65	10.65	
				MIMO B	2.62	2.62	5.63	10.63	
				Combined A+B	5.64	5.64	8.65	13.65	
		175	5875	MIMO A	1.42	1.42	4.43	9.43	
MIMO B				2.58	2.58	5.59	10.59		
Combined A+B				5.05	5.05	8.06	13.06		
802.11ac80		VHT0	171	5855	SISO A	-1.53	-1.53	1.48	6.48
					SISO B	-1.73	-1.73	1.28	6.28
	MIMO A				-3.04	-3.04	-0.03	4.97	
	MIMO B				-3.01	-3.01	0.00	5.00	
	Combined A+B				-0.01	-0.01	3.00	8.00	
802.11ac160	VHT0	163	5815	SISO A	-9.27	-9.27	-6.26	-1.26	
				SISO B	-10.07	-10.07	-7.06	-2.06	
				MIMO A	-9.79	-9.70	-6.69	-1.69	
				MIMO B	-11.03	-10.94	-7.93	-2.93	
				Combined A+B	-7.36	-7.26	-4.25	0.75	

* Maximum values are the duty cycle compensated values calculated from the average (measured)

Note :PSD [dBm/500kHz] corresponds to the measurement done using a RBW = 500kHz of the spectrum analyser. To obtain the PSD [dBm/1MHz] a correction factor is applied: $10\log\left(\frac{1MHz}{500kHz}\right) = +3.01dB$

Mode	Rate	Channel	Freq [MHz]	Antenna	Average conducted PSD [dBm/500kHz]	Max.* conducted PSD [dBm/500kHz]	Max.* conducted PSD [dBm/MHz]	EIRP PSD* [dBm/MHz]
802.11ax20	HE0	169	5845	SISO A	5.60	5.60	8.61	13.61
				SISO B	5.75	5.75	8.76	13.76
				MIMO A	2.60	2.60	5.61	10.61
				MIMO B	2.57	2.57	5.58	10.58
				Combined A+B	5.60	5.60	8.61	13.61
		173	5865	SISO A	5.82	5.82	8.83	13.83
				SISO B	5.67	5.67	8.68	13.68
				MIMO A	2.75	2.75	5.76	10.76
				MIMO B	2.69	2.69	5.70	10.70
				Combined A+B	5.73	5.73	8.74	13.74
		177	5885	SISO A	5.65	5.65	8.66	13.66
				SISO B	5.77	5.77	8.78	13.78
				MIMO A	2.53	2.53	5.54	10.54
				MIMO B	2.64	2.64	5.65	10.65
				Combined A+B	5.60	5.60	8.61	13.61
802.11ax40	HE0	167	5835	SISO A	3.55	3.55	6.56	11.56
				SISO B	3.38	3.38	6.39	11.39
				MIMO A	2.79	2.79	5.80	10.80
				MIMO B	2.76	2.76	5.77	10.77
				Combined A+B	5.79	5.79	8.80	13.80
		175	5875	SISO A	3.03	3.03	6.04	11.04
				SISO B	3.17	3.17	6.18	11.18
				MIMO A	1.60	1.60	4.61	9.61
				MIMO B	2.65	2.65	5.66	10.66
				Combined A+B	5.17	5.17	8.18	13.18
802.1axc80	HE0	171	5855	SISO A	-1.76	-1.76	1.25	6.25
				SISO B	-2.07	-2.07	0.94	5.94
				MIMO A	-3.38	-3.38	-0.37	4.63
				MIMO B	-3.36	-3.36	-0.35	4.65
				Combined A+B	-0.36	-0.36	2.65	7.65
802.11ax160	HE0	163	5815	SISO A	-8.85	-8.85	-5.84	-0.84
				SISO B	-10.20	-10.20	-7.19	-2.19
				MIMO A	-9.96	-9.83	-6.82	-1.82
				MIMO B	-11.05	-10.92	-7.91	-2.91
				Combined A+B	-7.46	-7.33	-4.32	0.68

* Maximum values are the duty cycle compensated values calculated from the average (measured)

Max Value

Min Value

Note :PSD [dBm/500KHz] corresponds to the measurement done using RBW = 500KHz. To obtain the PSD [dBm/1MHz] a correction factor is applied: $10\log\left(\frac{1MHz}{500kHz}\right) = +3.01dB$

See Section B.3.4. for the screenshot results

B.2.3 Undesirable emission limits : out of band (Conducted)Test limits

FCC part	Limits
15.407 (b) (5) (iii)	All emissions below 5.725 GHz shall not exceed an e.i.r.p of -27 dBm/MHz at 5.65GHz increasing linearly to 10dBm/MHz at 5.7 GHz, and from 5.7GHz increasing linearly to a level of 15.6 dBm/MHz at 5.72GHz, and from 5.72 GHz increasing linearly to a level of 27dBm/MHz at 5.725GHz.
15.407 (b) (5) (ii)	All emissions at or above 5.895GHz shall not exceed an e.i.r.p of -5dBm/MHz and shall decrease linearly to an e.i.r.p of -27dBm/MHz at or above 5.925GHz.

Test procedure

The conducted setup shown in section *Test & System Description* was used to measure undesirable emissions on the Band Edge domain. The antenna terminal of the EUT is connected to the spectrum analyzer through an attenuator, and the spectrum analyzer reading is compensated to include the RF path loss and the declared antenna gain.

For lower OOBE, Peak detector is used according to FCC OET KDB 789033 D02 v02r01.

For upper OOBE, RMS detector is used according to FCC OET KDB 291074 D01 v01.

See Section B.3.5. for the screenshot results.

B.2.4 Radiated spurious emission

Standard references

FCC part	Limits																				
15.407 (b) (5) (ii)	For transmitters operating solely in the 5.850-5.895 GHz band or operating on a channel that spans across 5.725-5.895 GHz: For a client device, all emissions at or above 5.895 GHz shall not exceed an e.i.r.p. of -5 dBm/MHz and shall decrease linearly to an e.i.r.p. of -27 dBm/MHz at or above 5.925 GHz.																				
15.407 (b) (5) (iii)	For a client device or indoor access point or subordinate device, all emissions below 5.725 GHz shall not exceed an e.i.r.p. of -27 dBm/MHz at 5.65 GHz increasing linearly to 10 dBm/MHz at 5.7 GHz, and from 5.7 GHz increasing linearly to a level of 15.6 dBm/MHz at 5.72 GHz, and from 5.72 GHz increasing linearly to a level of 27 dBm/MHz at 5.725 GHz.																				
15.209	<p>Radiated emissions which fall in the restricted bands, as defined in §15.205(a), must also comply with the radiated emission limits specified in §15.209(a):</p> <table border="1"> <thead> <tr> <th>Freq Range (MHz)</th> <th>Field Strength (μV/m)</th> <th>Field Strength (dBμV/m)</th> <th>Meas. Distance (m)</th> </tr> </thead> <tbody> <tr> <td>30-88</td> <td>100</td> <td>40</td> <td>3</td> </tr> <tr> <td>88-216</td> <td>150</td> <td>43.5</td> <td>3</td> </tr> <tr> <td>216-960</td> <td>200</td> <td>46</td> <td>3</td> </tr> <tr> <td>Above 960</td> <td>500</td> <td>54</td> <td>3</td> </tr> </tbody> </table> <p>The emission limits shown in the above table are based on measurements employing CISPR quasi-peak detector except for the frequency bands 9-90 kHz, 110-490 kHz and above 1000 MHz. Radiated emission limits in these three bands are based on measurements employing an average detector.</p> <p>For average radiated emission measurements above 1000 MHz, there is also a limit specified when measuring with peak detector function, corresponding to 20 dB above the indicated values in the table.</p>	Freq Range (MHz)	Field Strength (μ V/m)	Field Strength (dB μ V/m)	Meas. Distance (m)	30-88	100	40	3	88-216	150	43.5	3	216-960	200	46	3	Above 960	500	54	3
Freq Range (MHz)	Field Strength (μ V/m)	Field Strength (dB μ V/m)	Meas. Distance (m)																		
30-88	100	40	3																		
88-216	150	43.5	3																		
216-960	200	46	3																		
Above 960	500	54	3																		

Test procedure

The radiated setups shown in section *Test & System Description* were used to measure the radiated spurious emissions.

Depending of the frequency range and bands being tested, different antennas and filters were used.

- For frequencies less than or equal to 1000 MHz, measurements were made with the CISPR quasi-peak detector with a resolution bandwidth of 120kHz and a video bandwidth 3 times of the resolution bandwidth.
- For restricted bands, measurements above 1000 MHz were performed using average and peak detectors with a minimum resolution bandwidth of 1 MHz and a video bandwidth 3 times of the resolution bandwidth
- For unrestricted bands, measurements above 1000 MHz were performed using RMS and peak detectors with a minimum resolution bandwidth of 1 MHz and a video bandwidth 3 times of the resolution bandwidth

The final measurement is done by varying the antenna height, the EUT azimuth over 360° and for both Vertical and Horizontal polarizations.

The radiated spurious emission was measured on the worst case configuration selected from the chapter B.1 and using the low, middle and high channels.

Test Results

30 MHz – 1 GHz, Radiated spurious emissions**Radiated Spurious – All modes**

Frequency	QuasiPeak	Limit	Margin	Polar
MHz	dB μ V/m	dB μ V/m	dB μ V/m	---
74.9	37.0	40.0	3.0	H

Note 1: The detected spurious signals do not depend on either the operating channel or the modulation mode.

[802.11a](#)**1 GHz – 40 GHz, 802.11a, 6Mbps, Chain A****Radiated Spurious – CH169**

Frequency	Level	Detector	Limit	Margin	Polar
MHz	dB μ V/m	---	dB μ V/m	dB	---
3399.0	46.1	RMS	68.2	22.1	V
3399.5	57.8	Peak	88.2	30.4	V
17789.8	51.2	Peak	74.0	22.8	H
17809.1	40.0	Average	54.0	14.0	H
39633.1	57.2	Peak	74.0	16.8	V
39653.8	46.0	Average	54.0	8.0	H

Radiated Spurious – CH173

Frequency	Level	Detector	Limit	Margin	Polar
MHz	dB μ V/m	---	dB μ V/m	dB	---
3374.5	59.6	Peak	88.2	28.6	H
3376.5	46.4	RMS	68.2	21.8	V
17785.4	50.9	Peak	74.0	23.1	H
17826.0	40.0	Average	54.0	14.1	V
31052.4	37.5	RMS	68.2	30.7	V
31053.8	50.6	Peak	88.2	37.6	V

Radiated Spurious – CH177

Frequency	Level	Detector	Limit	Margin	Polar
MHz	dBµV/m	---	dBµV/m	dB	---
7280.9	56.4	Peak	74.0	17.6	V
7350.6	44.2	Average	54.0	9.8	H
17792.7	40.4	Average	54.0	13.6	H
17794.6	51.2	Peak	74.0	22.8	V
39501.9	56.3	Peak	74.0	17.7	H
39604.6	45.7	Average	54.0	8.3	V

1 GHz – 40 GHz, 802.11a, 6Mbps, Chain B

Radiated Spurious – CH169

Frequency	Level	Detector	Limit	Margin	Polar
MHz	dBµV/m	---	dBµV/m	dB	---
3392.5	58.0	Peak	88.2	30.2	V
3400.0	46.1	RMS	68.2	22.1	H
17780.1	39.9	Average	54.0	14.1	H
17816.3	51.0	Peak	74.0	23.0	V
39584.9	46.2	Average	54.0	7.8	V
39688.5	56.7	Peak	74.0	17.3	H

Radiated Spurious – CH173

Frequency	Level	Detector	Limit	Margin	Polar
MHz	dBµV/m	---	dBµV/m	dB	---
6841.7	43.8	RMS	68.2	24.4	V
6849.1	56.2	Peak	88.2	32.0	H
17811.0	39.9	Average	54.0	14.1	H
17813.0	50.7	Peak	74.0	23.3	H
33872.9	38.3	RMS	68.2	29.9	H
33873.9	51.6	Peak	88.2	36.6	V

Radiated Spurious – CH177

Frequency	Level	Detector	Limit	Margin	Polar
MHz	dB μ V/m	---	dB μ V/m	dB	---
3376.0	46.6	RMS	68.2	21.6	H
3396.5	58.2	Peak	88.2	30.0	H
17787.8	50.8	Peak	74.0	23.2	H
17825.5	39.9	Average	54.0	14.1	H
23490.1	35.0	RMS	68.2	33.2	V
23490.1	48.0	Peak	88.2	40.2	H

802.11n

1 GHz – 40 GHz, 802.11n20, HT0, Chain A

Radiated Spurious – CH169

Frequency	Level	Detector	Limit	Margin	Polar
MHz	dB μ V/m	---	dB μ V/m	dB	---
3378.0	58.3	Peak	88.2	29.9	V
3399.5	46.3	RMS	68.2	21.9	H
17109.2	52.0	Peak	88.2	36.2	H
17131.5	41.0	RMS	68.2	27.1	H
39560.8	56.6	Peak	74.0	17.4	H
39644.7	46.0	Average	54.0	8.0	H

Radiated Spurious – CH173

Frequency	Level	Detector	Limit	Margin	Polar
MHz	dB μ V/m	---	dB μ V/m	dB	---
3384.5	59.2	Peak	88.2	29.0	H
3388.0	46.1	RMS	68.2	22.1	H
11733.1	49.4	Peak	74.0	24.6	H
11733.1	39.1	Average	54.0	14.8	V
39611.9	57.0	Peak	74.0	17.0	V
39654.3	46.1	Average	54.0	7.9	V

Radiated Spurious – CH177

Frequency	Level	Detector	Limit	Margin	Polar
MHz	dB μ V/m	---	dB μ V/m	dB	---
3376.0	46.5	RMS	68.2	21.7	V
3391.5	57.9	Peak	88.2	30.3	V
11768.4	39.5	Average	54.0	14.5	V
11772.2	49.9	Peak	74.0	24.1	H
39598.4	55.9	Peak	74.0	18.1	V
39692.4	45.7	Average	54.0	8.3	V

1 GHz – 40 GHz, 802.11n20, HT0, Chain B**Radiated Spurious – CH169**

Frequency	Level	Detector	Limit	Margin	Polar
MHz	dB μ V/m	---	dB μ V/m	dB	---
3370.5	59.0	Peak	88.2	29.2	V
3375.0	46.4	RMS	68.2	21.8	V
17061.8	52.0	Peak	88.2	36.2	V
17164.8	41.3	RMS	68.2	26.9	V
39611.4	46.0	Average	54.0	8.1	V
39632.6	56.3	Peak	74.0	17.7	H

Radiated Spurious – CH173

Frequency	Level	Detector	Limit	Margin	Polar
MHz	dB μ V/m	---	dB μ V/m	dB	---
3379.5	59.0	Peak	88.2	29.2	H
3390.0	46.1	RMS	68.2	22.1	H
17076.3	41.4	RMS	68.2	26.8	V
17155.6	52.2	Peak	88.2	36.0	H
39580.1	56.3	Peak	74.0	17.7	H
39636.5	45.7	Average	54.0	8.3	H

Radiated Spurious – CH177

Frequency	Level	Detector	Limit	Margin	Polar
MHz	dBµV/m	---	dBµV/m	dB	---
3376.5	46.5	RMS	68.2	21.8	H
3383.5	58.4	Peak	88.2	29.8	V
17133.9	40.7	RMS	68.2	27.5	H
17143.0	52.0	Peak	88.2	36.2	V
39653.8	56.3	Peak	74.0	17.7	H
39655.3	45.8	Average	54.0	8.2	V

1 GHz – 40 GHz, 802.11n20, HT8, Chain A+B**Radiated Spurious – CH169**

Frequency	Level	Detector	Limit	Margin	Polar
MHz	dBµV/m	---	dBµV/m	dB	---
3395.0	57.8	Peak	88.2	30.4	V
3400.0	46.1	RMS	68.2	22.1	H
17060.9	52.6	Peak	88.2	35.6	H
17105.8	41.3	RMS	68.2	26.9	V
26272.4	35.9	RMS	68.2	32.3	V
26272.4	49.5	Peak	88.2	38.7	H

Radiated Spurious – CH173

Frequency	Level	Detector	Limit	Margin	Polar
MHz	dBµV/m	---	dBµV/m	dB	---
3385.5	59.0	Peak	88.2	29.2	H
3389.0	46.1	RMS	68.2	22.1	V
17084.1	41.0	RMS	68.2	27.2	H
17142.1	52.5	Peak	88.2	35.7	H
39665.9	45.7	Average	54.0	8.3	V
39675.5	56.1	Peak	74.0	17.9	H

Radiated Spurious – CH177

Frequency	Level	Detector	Limit	Margin	Polar
MHz	dBμV/m	---	dBμV/m	dB	---
3374.5	58.4	Peak	88.2	29.8	V
3376.0	46.4	RMS	68.2	21.8	V
17076.3	52.1	Peak	88.2	36.1	H
17087.0	41.3	RMS	68.2	26.9	V
39636.5	45.7	Average	54.0	8.3	V
39683.7	56.4	Peak	74.0	17.6	H

1 GHz – 40 GHz, 802.11n40, HT0, Chain A

Radiated Spurious – CH167

Frequency	Level	Detector	Limit	Margin	Polar
MHz	dBμV/m	---	dBμV/m	dB	---
3375.5	46.4	RMS	68.2	21.8	H
3388.5	57.9	Peak	88.2	30.3	V
14414.6	37.1	RMS	68.2	31.1	H
14415.1	50.5	Peak	88.2	37.7	H
39595.0	56.7	Peak	74.0	17.3	H
39627.8	45.8	Average	54.0	8.2	H

Radiated Spurious – CH175

Frequency	Level	Detector	Limit	Margin	Polar
MHz	dBμV/m	---	dBμV/m	dB	---
3388.0	46.1	RMS	68.2	22.1	V
3388.0	58.3	Peak	88.2	29.9	H
17107.3	41.2	RMS	68.2	27.0	V
17131.9	51.8	Peak	88.2	36.4	V
39562.2	45.9	Average	54.0	8.1	V
39566.6	56.6	Peak	74.0	17.4	H

1 GHz – 40 GHz, 802.11n40, HT0, Chain B

Radiated Spurious – CH167

Frequency	Level	Detector	Limit	Margin	Polar
MHz	dB μ V/m	---	dB μ V/m	dB	---
3376.0	46.4	RMS	68.2	21.8	V
3376.0	59.7	Peak	88.2	28.5	H
17136.8	41.2	RMS	68.2	27.0	H
17156.1	51.8	Peak	88.2	36.4	H
39637.9	45.9	Average	54.0	8.1	H
39675.0	56.6	Peak	74.0	17.4	H

Radiated Spurious – CH175

Frequency	Level	Detector	Limit	Margin	Polar
MHz	dB μ V/m	---	dB μ V/m	dB	---
3375.0	46.4	RMS	68.2	21.8	H
3400.0	58.4	Peak	88.2	29.8	V
17055.1	41.2	RMS	68.2	27.0	H
17106.3	51.9	Peak	88.2	36.3	V
30276.1	37.5	RMS	68.2	30.7	V
30276.1	50.0	Peak	88.2	38.2	V

1 GHz – 40 GHz, 802.11n40, HT8, Chain A+B

Radiated Spurious – CH167

Frequency	Level	Detector	Limit	Margin	Polar
MHz	dB μ V/m	---	dB μ V/m	dB	---
3381.0	46.2	RMS	68.2	22.0	V
3398.5	58.5	Peak	88.2	29.7	H
17073.9	53.1	Peak	88.2	35.1	H
17102.5	41.1	RMS	68.2	27.1	V
39574.8	45.7	Average	54.0	8.3	V
39636.5	56.7	Peak	74.0	17.3	H

Radiated Spurious – CH175

Frequency	Level	Detector	Limit	Margin	Polar
MHz	dBµV/m	---	dBµV/m	dB	---
3393.5	45.9	RMS	68.2	22.3	H
3399.5	58.7	Peak	88.2	29.5	H
17103.4	52.4	Peak	88.2	35.8	V
17135.3	41.0	RMS	68.2	27.2	V
39608.0	45.7	Average	54.0	8.3	V
39696.7	56.7	Peak	74.0	17.3	H

802.11ax

1 GHz – 40 GHz, 802.11ax20, HE0, Chain A

Radiated Spurious – CH169

Frequency	Level	Detector	Limit	Margin	Polar
MHz	dBµV/m	---	dBµV/m	dB	---
3398.5	57.5	Peak	88.2	30.7	H
3398.5	46.2	RMS	68.2	22.0	V
17087.0	40.7	RMS	68.2	27.5	H
17093.3	52.4	Peak	88.2	35.8	H
39557.4	56.9	Peak	74.0	17.1	H
39665.4	45.9	Average	54.0	8.1	H

Radiated Spurious – CH173

Frequency	Level	Detector	Limit	Margin	Polar
MHz	dBµV/m	---	dBµV/m	dB	---
3369.5	46.4	RMS	68.2	21.8	V
3385.5	58.7	Peak	88.2	29.5	H
17087.0	41.2	RMS	68.2	27.0	V
17140.2	52.2	Peak	88.2	36.0	V
39628.8	56.8	Peak	74.0	17.2	H
39637.9	46.0	Average	54.0	8.0	V

Radiated Spurious – CH177

Frequency	Level	Detector	Limit	Margin	Polar
MHz	dB μ V/m	---	dB μ V/m	dB	---
3372.0	59.8	Peak	88.2	28.4	V
3374.5	46.4	RMS	68.2	21.8	V
17138.7	52.2	Peak	88.2	35.9	H
17152.7	41.0	RMS	68.2	27.2	V
39616.2	56.5	Peak	74.0	17.5	V
39674.6	45.6	Average	54.0	8.4	V

1 GHz – 40 GHz, 802.11ax20, HE0, Chain B**Radiated Spurious – CH169**

Frequency	Level	Detector	Limit	Margin	Polar
MHz	dB μ V/m	---	dB μ V/m	dB	---
3375.5	46.4	RMS	68.2	21.8	V
3394.0	58.3	Peak	88.2	29.9	V
17063.3	51.6	Peak	88.2	36.6	V
17151.3	41.0	RMS	68.2	27.2	H
39586.3	45.8	Average	54.0	8.2	H
39670.2	56.5	Peak	74.0	17.5	V

Radiated Spurious – CH173

Frequency	Level	Detector	Limit	Margin	Polar
MHz	dB μ V/m	---	dB μ V/m	dB	---
3376.0	46.5	RMS	68.2	21.8	V
3377.0	58.3	Peak	88.2	29.9	H
17072.5	51.5	Peak	88.2	36.7	H
17105.8	41.0	RMS	68.2	27.2	H
27334.1	37.5	RMS	68.2	30.7	V
27334.1	49.9	Peak	88.2	38.3	V

Radiated Spurious – CH177

Frequency	Level	Detector	Limit	Margin	Polar
MHz	dB μ V/m	---	dB μ V/m	dB	---
3377.5	58.5	Peak	88.2	29.7	V
3377.5	46.4	RMS	68.2	21.8	H
17096.7	41.2	RMS	68.2	27.0	H
17153.7	52.5	Peak	88.2	35.8	V
39612.4	45.9	Average	54.0	8.1	V
39686.6	57.4	Peak	74.0	16.6	V

1 GHz – 40 GHz, 802.11ax20, HE0, Chain A+B

Radiated Spurious – CH169

Frequency	Level	Detector	Limit	Margin	Polar
MHz	dB μ V/m	---	dB μ V/m	dB	---
3365.0	46.6	RMS	68.2	21.6	H
3370.5	59.0	Peak	88.2	29.2	H
17030.4	52.4	Peak	88.2	35.8	V
17066.7	41.0	RMS	68.2	27.2	V
39665.9	45.9	Average	54.0	8.1	H
39718.9	56.6	Peak	74.0	17.4	H

Radiated Spurious – CH173

Frequency	Level	Detector	Limit	Margin	Polar
MHz	dB μ V/m	---	dB μ V/m	dB	---
4037.5	39.2	Average	54.0	14.8	H
4038.3	52.0	Peak	74.0	22.0	H
17101.0	52.0	Peak	88.2	36.2	H
17163.8	41.0	RMS	68.2	27.2	V
32209.1	38.8	RMS	68.2	29.4	H
32209.1	50.9	Peak	88.2	37.3	H

Radiated Spurious – CH177

Frequency	Level	Detector	Limit	Margin	Polar
MHz	dB μ V/m	---	dB μ V/m	dB	---
3374.5	59.0	Peak	88.2	29.2	H
3377.0	46.7	RMS	68.2	21.5	V
17063.3	41.5	RMS	68.2	26.7	V
17122.3	52.2	Peak	88.2	36.0	H
39415.6	56.5	Peak	74.0	17.5	H
39665.4	45.8	Average	54.0	8.2	H

1 GHz – 40 GHz, 802.11ax40, HE0, Chain A

Radiated Spurious – CH167

Frequency	Level	Detector	Limit	Margin	Polar
MHz	dB μ V/m	---	dB μ V/m	dB	---
3385.0	58.8	Peak	88.2	29.4	V
3394.0	46.1	RMS	68.2	22.1	H
17105.8	41.3	RMS	68.2	26.9	V
17115.0	52.2	Peak	88.2	36.0	H
37299.5	40.3	RMS	68.2	27.9	V
37299.5	53.1	Peak	88.2	35.1	V

Radiated Spurious – CH175

Frequency	Level	Detector	Limit	Margin	Polar
MHz	dB μ V/m	---	dB μ V/m	dB	---
3376.0	46.4	RMS	68.2	21.8	H
3380.0	58.8	Peak	88.2	29.4	V
17092.3	52.6	Peak	88.2	35.6	H
17096.7	41.3	RMS	68.2	26.9	H
39579.6	56.3	Peak	74.0	17.7	V
39627.8	45.8	Average	54.0	8.2	V

1 GHz – 40 GHz, 802.11ax40, HE0, Chain B

Radiated Spurious – CH167

Frequency	Level	Detector	Limit	Margin	Polar
MHz	dB μ V/m	---	dB μ V/m	dB	---
3369.0	58.6	Peak	88.2	29.6	V
3373.5	46.5	RMS	68.2	21.7	V
17079.2	41.2	RMS	68.2	27.0	H
17183.7	52.2	Peak	88.2	36.0	V
39623.0	56.6	Peak	74.0	17.4	V
39721.3	45.7	Average	54.0	8.3	H

Radiated Spurious – CH175

Frequency	Level	Detector	Limit	Margin	Polar
MHz	dB μ V/m	---	dB μ V/m	dB	---
3376.0	46.5	RMS	68.2	21.7	V
3379.0	59.6	Peak	88.2	28.6	V
17065.2	41.2	RMS	68.2	27.0	V
17131.9	52.0	Peak	88.2	36.2	H
39631.6	45.7	Average	54.0	8.3	H
39634.1	56.6	Peak	74.0	17.4	H

1 GHz – 40 GHz, 802.11ax40, HE0, Chain A+B

Radiated Spurious – CH167

Frequency	Level	Detector	Limit	Margin	Polar
MHz	dB μ V/m	---	dB μ V/m	dB	---
3388.0	57.8	Peak	88.2	30.4	H
3400.0	46.2	RMS	68.2	22.0	H
17114.5	52.5	Peak	88.2	35.8	H
17149.8	41.0	RMS	68.2	27.2	H
26824.0	37.0	RMS	68.2	31.2	H
26824.5	50.1	Peak	88.2	38.1	V

Radiated Spurious – CH175

Frequency	Level	Detector	Limit	Margin	Polar
MHz	dBµV/m	---	dBµV/m	dB	---
3382.5	46.1	RMS	68.2	22.1	V
3394.5	58.5	Peak	88.2	29.7	V
17112.6	41.1	RMS	68.2	27.1	H
17153.7	51.7	Peak	88.2	36.5	V
39592.6	56.8	Peak	74.0	17.2	V
39636.9	46.0	Average	54.0	8.0	H

1 GHz – 40 GHz, 802.11ax80, HE0, Chain A

Radiated Spurious – CH171

Frequency	Level	Detector	Limit	Margin	Polar
MHz	dBµV/m	---	dBµV/m	dB	---
3395.0	58.2	Peak	88.2	30.0	V
3395.5	46.1	RMS	68.2	22.1	H
17148.8	41.1	RMS	68.2	27.1	V
17155.1	51.9	Peak	88.2	36.3	H
39607.5	56.9	Peak	74.0	17.1	V
39694.3	45.7	Average	54.0	8.3	V

1 GHz – 40 GHz, 802.11ax80, HE0, Chain B

Radiated Spurious – CH171

Frequency	Level	Detector	Limit	Margin	Polar
MHz	dBµV/m	---	dBµV/m	dB	---
3376.0	46.4	RMS	68.2	21.8	H
3387.0	58.7	Peak	88.2	29.5	H
17118.9	51.8	Peak	88.2	36.4	V
17157.1	41.0	RMS	68.2	27.2	V
39569.4	56.3	Peak	74.0	17.7	H
39634.1	45.7	Average	54.0	8.3	V

1 GHz – 40 GHz, 802.11ax80, HE0, Chain A+B

Radiated Spurious – CH171

Frequency	Level	Detector	Limit	Margin	Polar
MHz	dB μ V/m	---	dB μ V/m	dB	---
3376.0	46.4	RMS	68.2	21.8	H
3380.5	59.3	Peak	88.2	28.9	H
17076.8	41.1	RMS	68.2	27.1	V
17157.1	52.8	Peak	88.2	35.4	V
39636.9	56.3	Peak	74.0	17.7	H
39658.2	45.8	Average	54.0	8.2	V

1 GHz – 40 GHz, 802.11ax160, HE0, Chain A

Radiated Spurious – CH163

Frequency	Level	Detector	Limit	Margin	Polar
MHz	dB μ V/m	---	dB μ V/m	dB	---
3311.0	59.4	Peak	88.2	28.8	V
3313.5	46.2	RMS	68.2	22.0	V
17109.7	52.0	Peak	88.2	36.2	V
17127.1	41.0	RMS	68.2	27.2	H
39641.8	56.2	Peak	74.0	17.8	H
39645.6	45.8	Average	54.0	8.2	V

1 GHz – 40 GHz, 802.11ax160, HE0, Chain B

Radiated Spurious – CH163

Frequency	Level	Detector	Limit	Margin	Polar
MHz	dB μ V/m	---	dB μ V/m	dB	---
3368.5	46.4	RMS	68.2	21.8	H
3375.5	58.1	Peak	88.2	30.1	V
17094.2	52.5	Peak	88.2	35.7	V
17153.7	41.3	RMS	68.2	26.9	V
39650.0	45.9	Average	54.0	8.1	H
39731.4	57.0	Peak	74.0	17.0	V

1 GHz – 40 GHz, 802.11ax160, HE0, Chain A+B

Radiated Spurious – CH163

Frequency	Level	Detector	Limit	Margin	Polar
MHz	dB μ V/m	---	dB μ V/m	dB	---
3374.0	46.7	RMS	68.2	21.5	V
3388.5	58.0	Peak	88.2	30.2	V
17073.0	52.4	Peak	88.2	35.8	V
17092.8	41.0	RMS	68.2	27.2	V
39599.3	56.6	Peak	74.0	17.4	H
39659.1	45.8	Average	54.0	8.2	V

802.11ac

1 GHz – 40 GHz, 802.11ac80, VHT0, Chain A

Radiated Spurious – CH171

Frequency	Level	Detector	Limit	Margin	Polar
MHz	dB μ V/m	---	dB μ V/m	dB	---
3399.0	58.1	Peak	88.2	30.1	V
3400.0	46.1	RMS	68.2	22.1	H
17788.3	51.5	Peak	74.0	22.6	V
17817.8	40.3	Average	54.0	13.7	V
39624.4	45.9	Average	54.0	8.1	V
39632.1	56.4	Peak	74.0	17.6	V

1 GHz – 40 GHz, 802.11ac80, VHT0, Chain B

Radiated Spurious – CH171

Frequency	Level	Detector	Limit	Margin	Polar
MHz	dB μ V/m	---	dB μ V/m	dB	---
3382.0	46.4	RMS	68.2	21.8	H
3390.0	59.1	Peak	88.2	29.1	V
17106.3	41.4	RMS	68.2	26.9	V
17131.9	52.7	Peak	88.2	35.5	H
39575.2	45.8	Average	54.0	8.2	H
39640.3	56.5	Peak	74.0	17.4	V

1 GHz – 40 GHz, 802.11ac80, VHT0, Chain A+B

Radiated Spurious – CH171

Frequency	Level	Detector	Limit	Margin	Polar
MHz	dB μ V/m	---	dB μ V/m	dB	---
3376.0	46.5	RMS	68.2	21.7	H
3388.5	58.5	Peak	88.2	29.8	V
17069.1	52.2	Peak	88.2	36.0	H
17102.9	41.0	RMS	68.2	27.2	V
39574.8	46.0	Average	54.0	8.0	H
39657.2	56.1	Peak	74.0	17.9	H

1 GHz – 40 GHz, 802.11ac160, VHT0, Chain A

Radiated Spurious – CH163

Frequency	Level	Detector	Limit	Margin	Polar
MHz	dB μ V/m	---	dB μ V/m	dB	---
3397.5	58.1	Peak	88.2	30.1	H
3400.0	46.3	RMS	68.2	21.9	H
17808.6	50.7	Peak	74.0	23.3	H
17816.8	40.2	Average	54.0	13.8	H
39654.3	56.6	Peak	74.0	17.4	V
39690.9	46.0	Average	54.0	8.0	H

1 GHz – 40 GHz, 802.11ac160, VHT0, Chain B

Radiated Spurious – CH163

Frequency	Level	Detector	Limit	Margin	Polar
MHz	dB μ V/m	---	dB μ V/m	dB	---
3376.0	46.5	RMS	68.2	21.7	H
3389.5	59.0	Peak	88.2	29.2	H
17113.1	53.0	Peak	88.2	35.2	H
17149.3	41.0	RMS	68.2	27.2	V
39648.0	45.8	Average	54.0	8.2	H
39705.9	56.4	Peak	74.0	17.6	H

1 GHz – 40 GHz, 802.11ac160, VHT0, Chain A+B

Radiated Spurious – CH163

Frequency	Level	Detector	Limit	Margin	Polar
MHz	dB μ V/m	---	dB μ V/m	dB	---
4608.7	40.5	Average	54.0	13.5	H
4608.7	53.5	Peak	74.0	20.5	V
17789.8	40.3	Average	54.0	13.7	V
17813.9	50.7	Peak	74.0	23.3	H
39590.7	46.1	Average	54.0	7.9	V
39648.0	57.1	Peak	74.0	16.9	H

B.3 Test Results Screenshot

B.3.1 6dB Bandwidth

SISO-B, 802.11a, 6Mbps-CH169

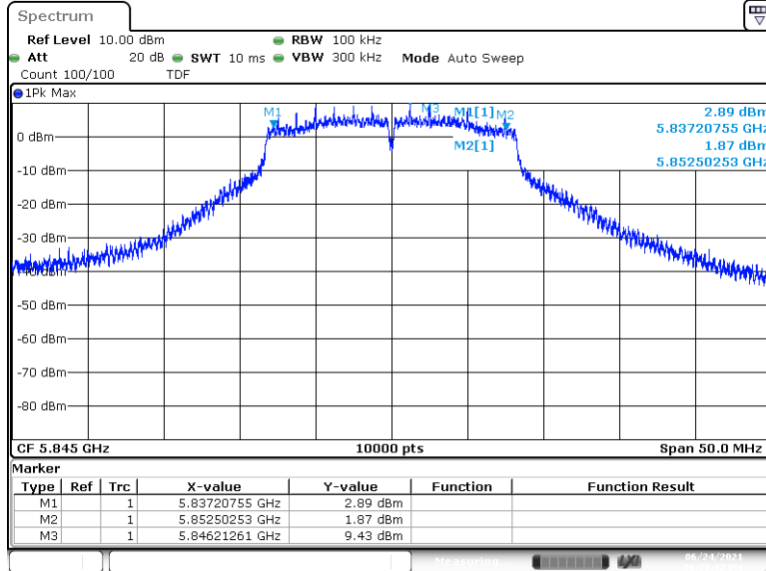

Date: 24.JUN.2021 18:39:33

MIMO-B, 802.11n20, HT8-CH177

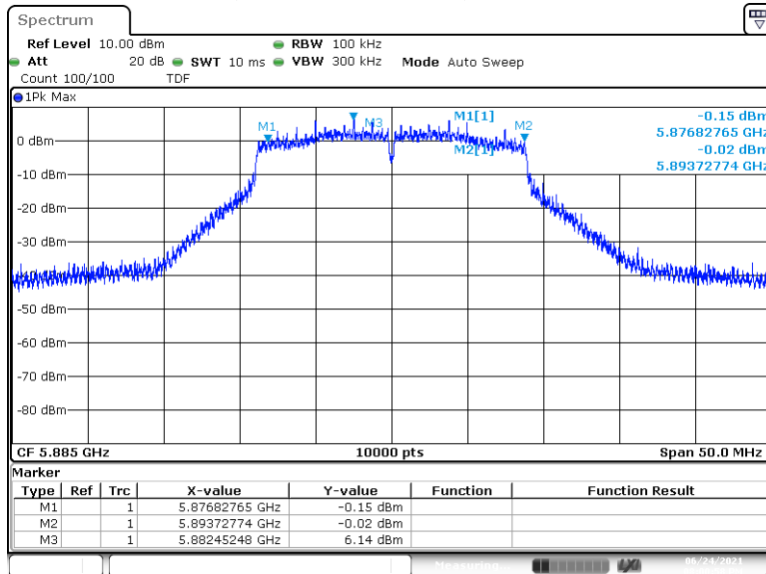

Date: 24.JUN.2021 20:00:58

MIMO-B, 802.11n40, HT8-CH175

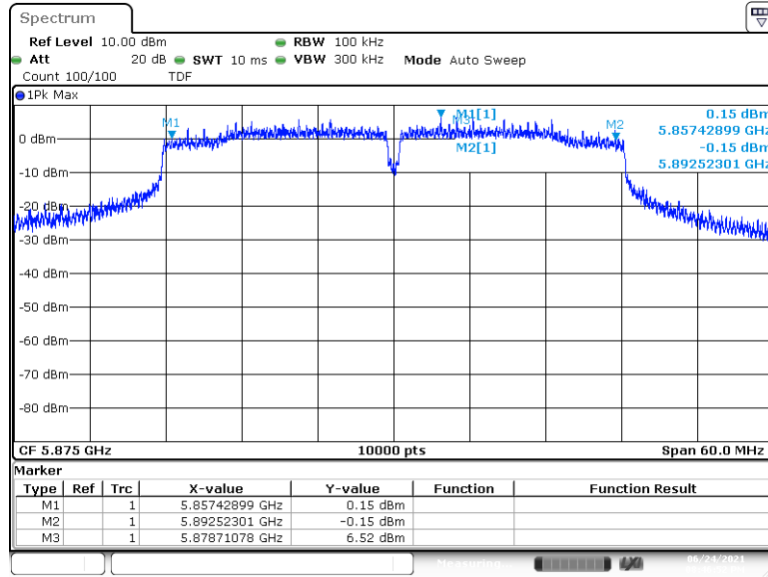

Date: 24 JUN 2021 20:46:52

SISO-B, 802.11ac80, VHT0-CH171

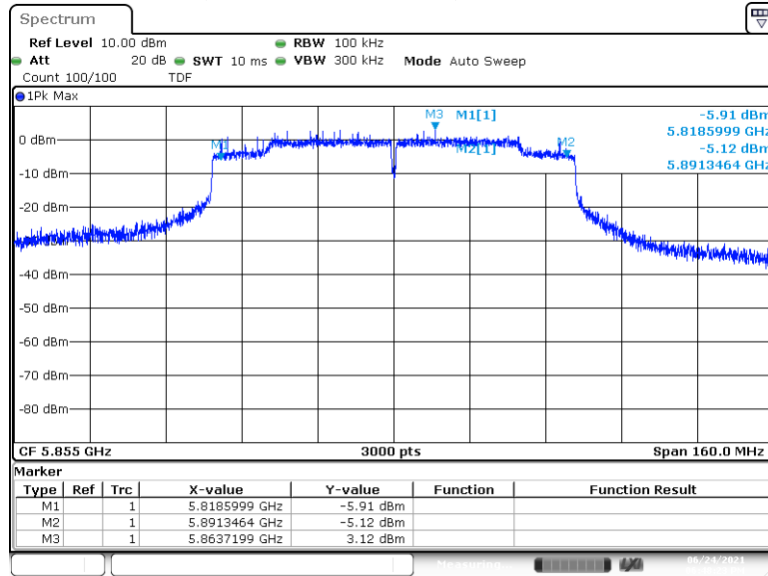

Date: 24 JUN 2021 18:48:24

MIMO-B, 802.11ac160, VHT0-CH163

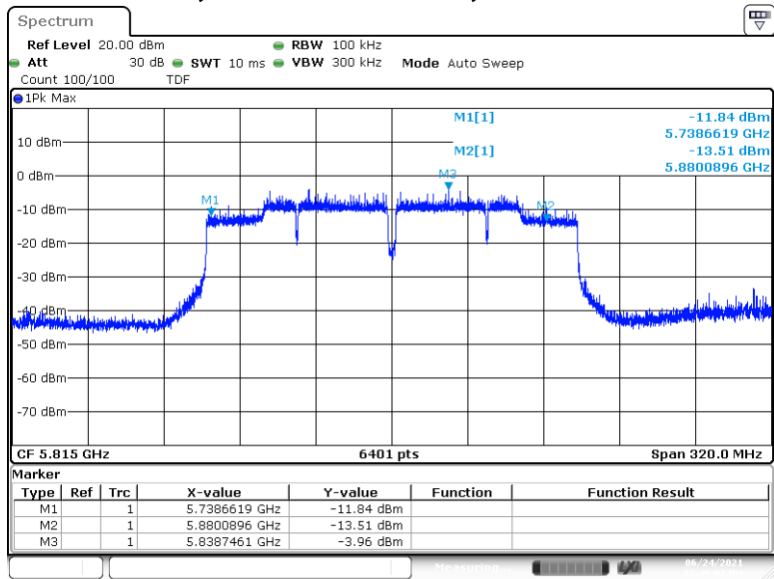

Date: 24 JUN 2021 20:49:06

MIMO-A, 802.11ax20, HE0-CH169

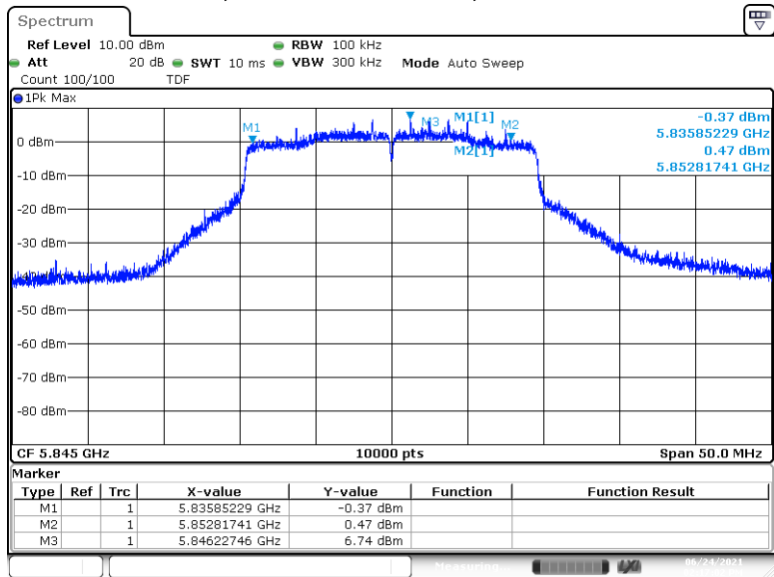

Date: 24 JUN 2021 14:17:02

SISO-A, 802.11ax40, HE0-CH175

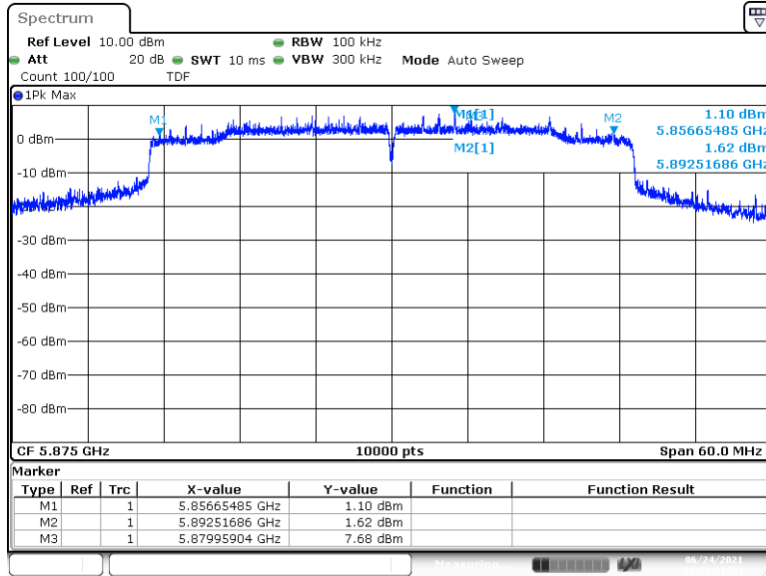

Date: 24.JUN.2021 13:01:31

SISO-B, 802.11ax80, HE0-CH171

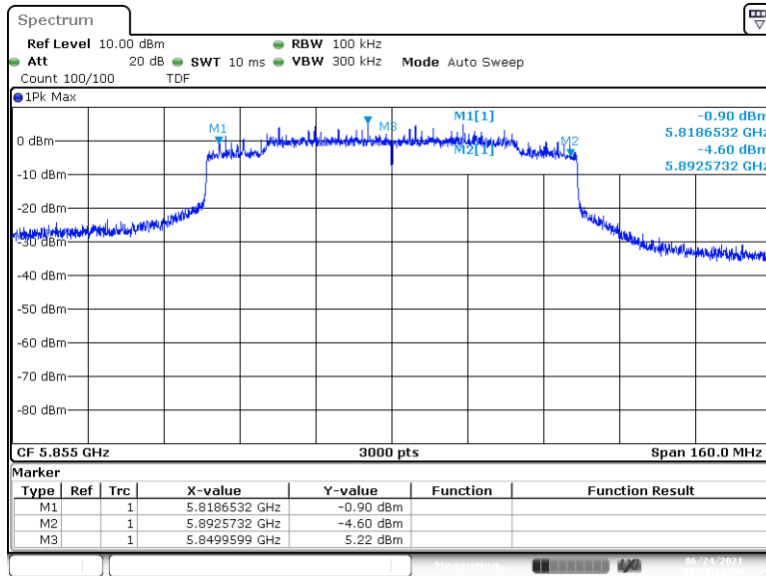

Date: 24.JUN.2021 18:56:11

SISO-A, 802.11ax160, HE0-CH163

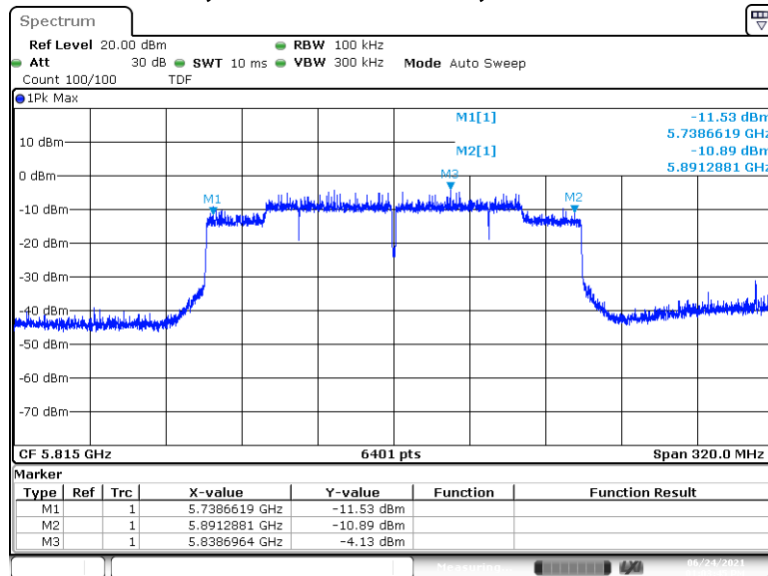

Date: 24.JUN.2021 13:03:45

B.3.2 99% Bandwidth

SISO-B, 802.11a, 6Mbps-CH177

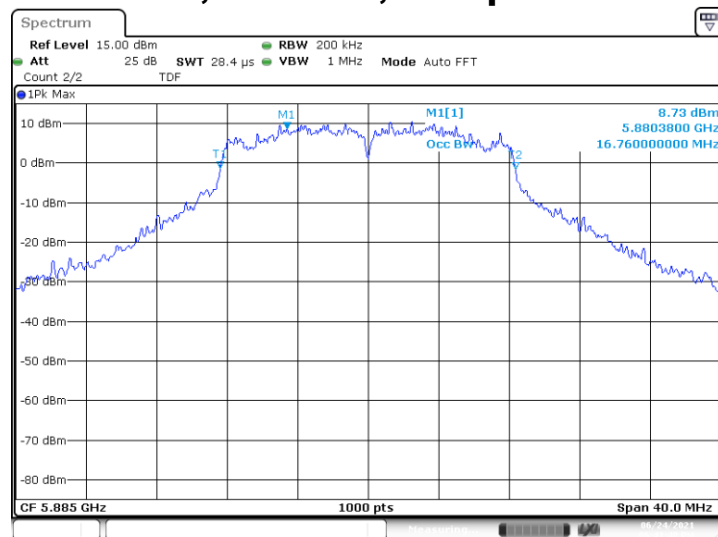

Date: 24.JUN.2021 18:41:48

SISO-B, 802.11n20, HT0-CH177

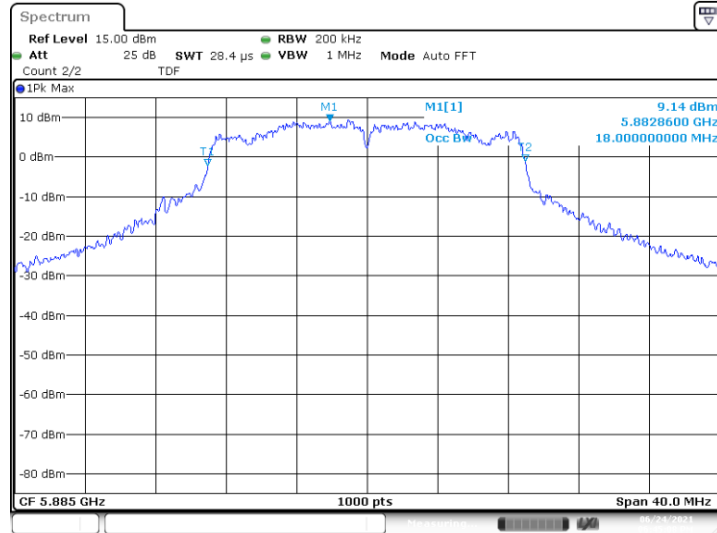

Date: 24.JUN.2021 18:45:08

SISO-B, 802.11n40, HT0-CH175

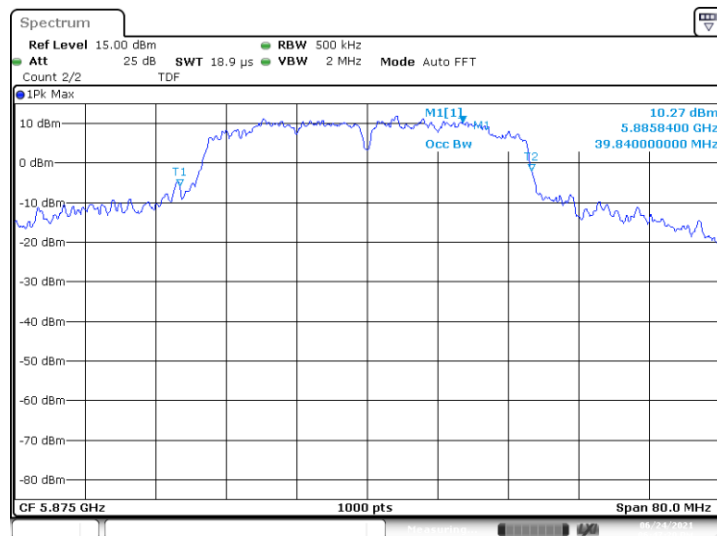

Date: 24.JUN.2021 18:47:20

SISO-B, 802.11ac80, VHT0-CH171

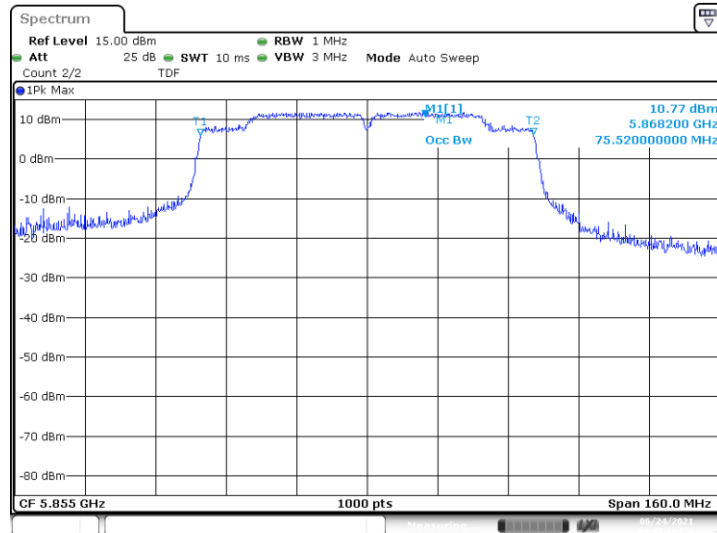

Date: 24.JUN.2021 18:48:27

SISO-A, 802.11ac160, VHT0-CH163

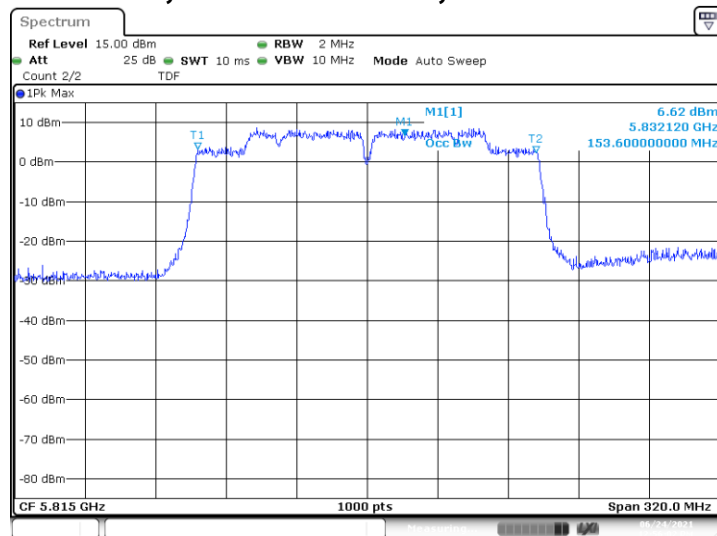

Date: 24.JUN.2021 12:58:03

SISO-B, 802.11ax20, HE0-CH173

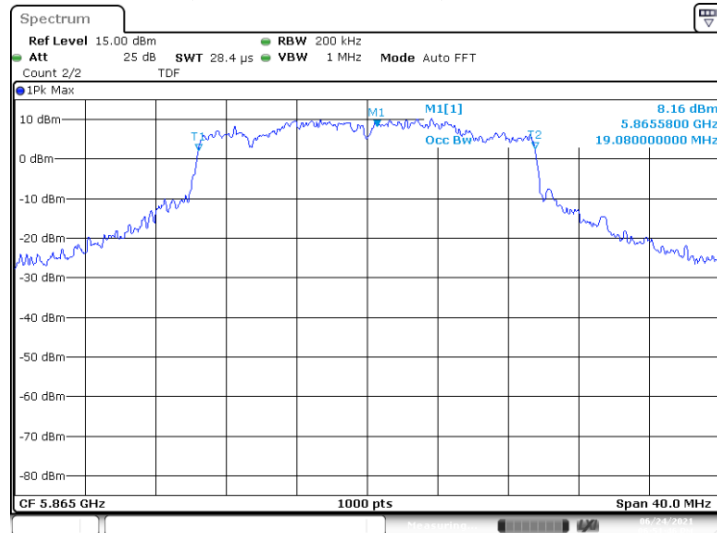

Date: 24.JUN.2021 18:51:47

SISO-A, 802.11ax40, HE0-CH167

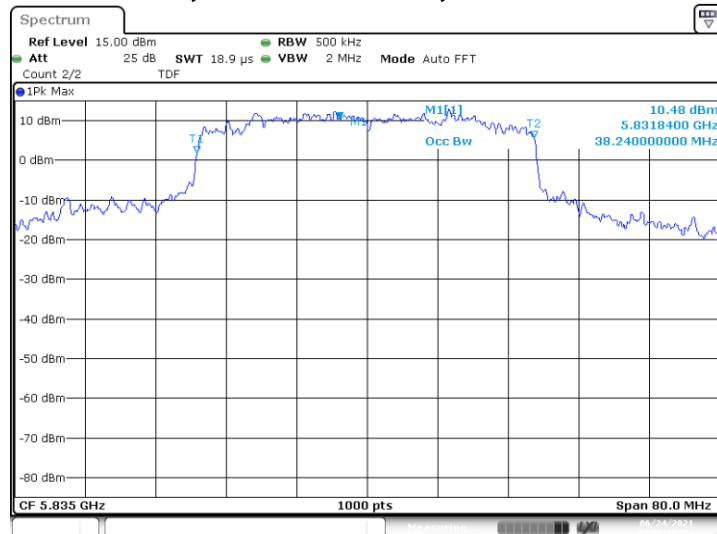

Date: 24.JUN.2021 13:00:29

SISO-B, 802.11ax80, HE0-CH171

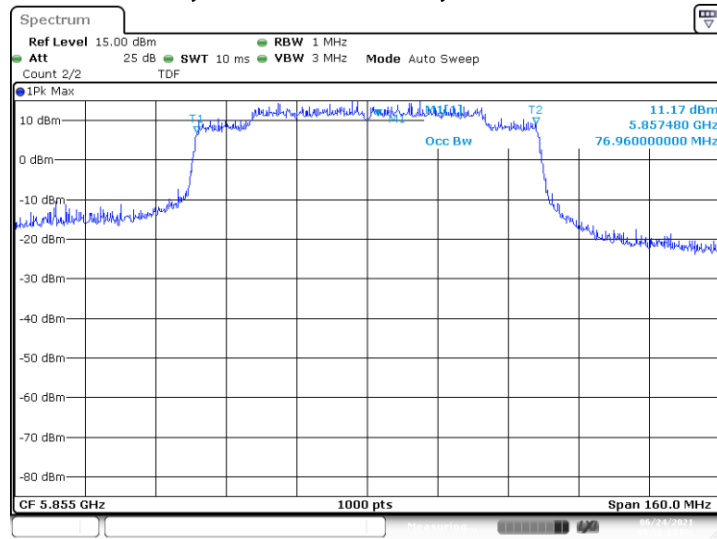

Date: 24.JUN.2021 18:53:14

SISO-A, 802.11ax160, HE0-CH163

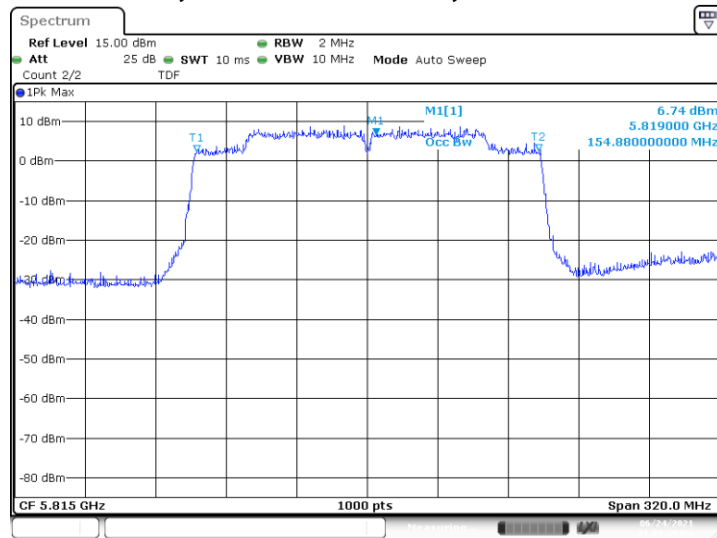

Date: 24.JUN.2021 13:03:43

B.3.3 Maximum output power

SISO-A, 802.11a, 6Mbps-CH-177

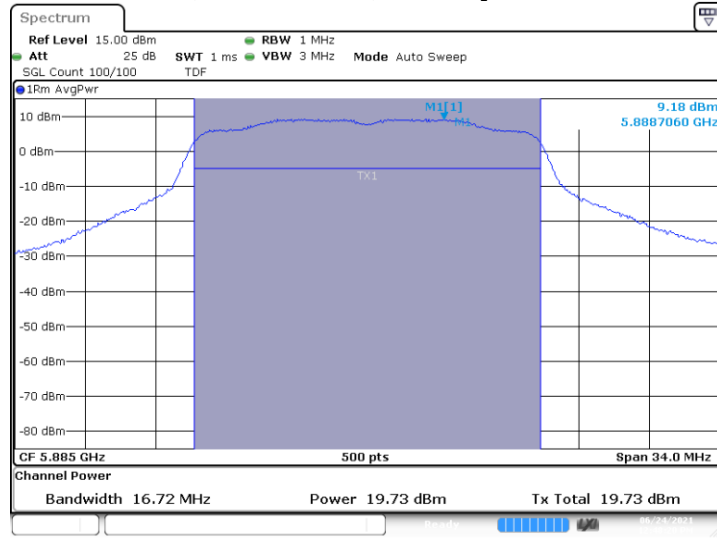

MIMO-A, 802.11n20, HT8-CH-173

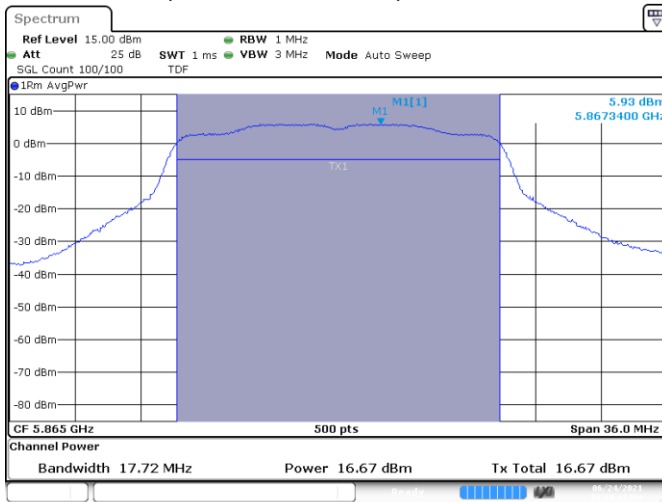

MIMO-B, 802.11n20, HT8-CH-173

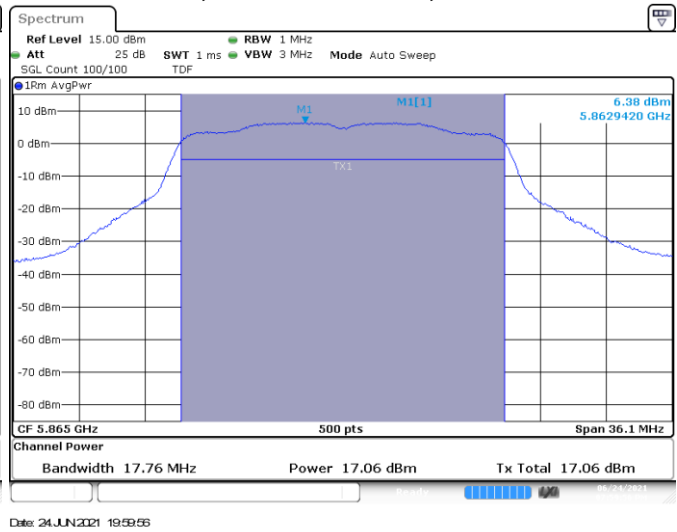

MIMO-A, 802.11n40, HT8-CH-167

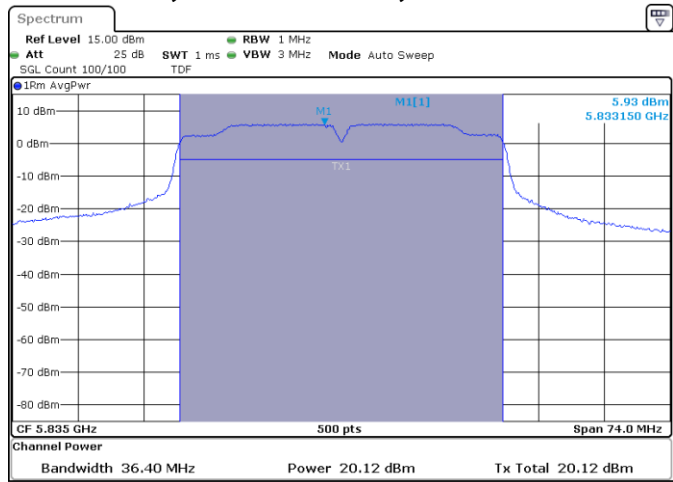

Date: 24.JUN.2021 14:12:27

MIMO-B, 802.11n40, HT8-CH-167

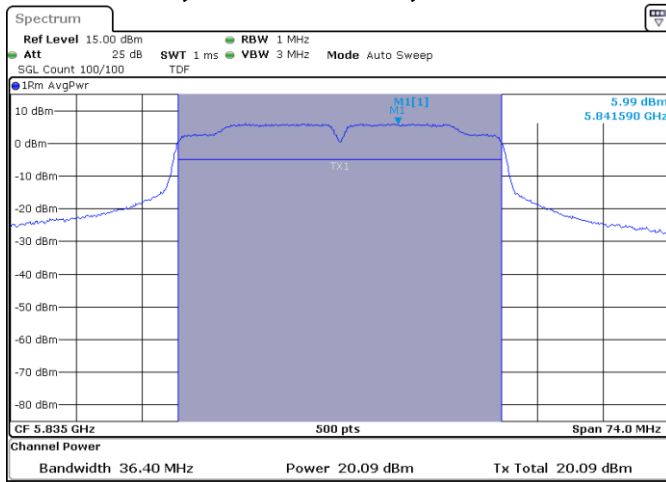

Date: 24.JUN.2021 20:02:10

MIMO-A, 802.11ac80, VHT0-CH171

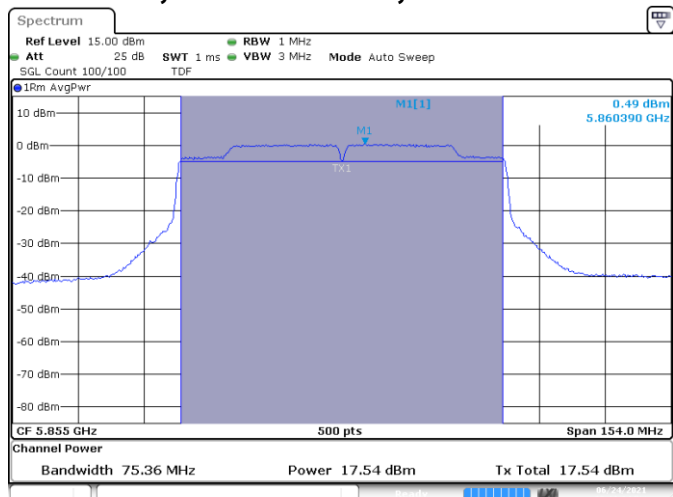

Date: 24.JUN.2021 15:12:05

MIMO-B, 802.11ac80, VHT0-CH171

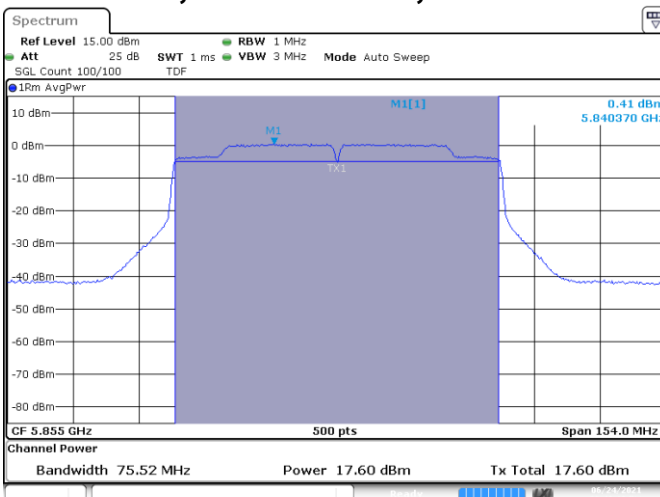

Date: 24.JUN.2021 21:48:18

MIMO-A, 802.11ac160, VHT0-CH163

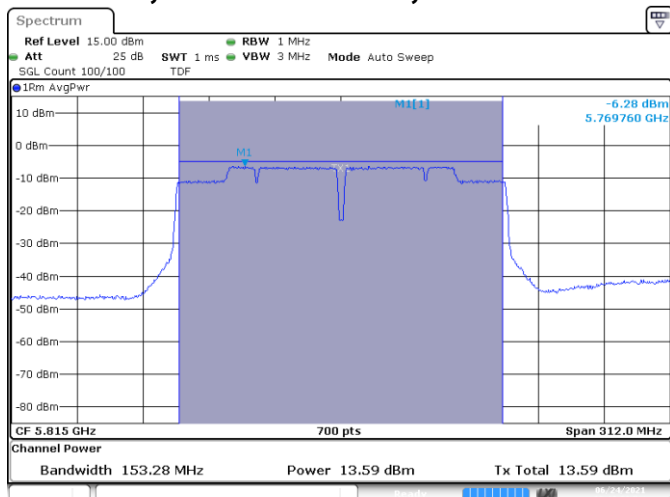

Date: 24.JUN.2021 15:18:50

MIMO-B, 802.11ac160, VHT0-CH163

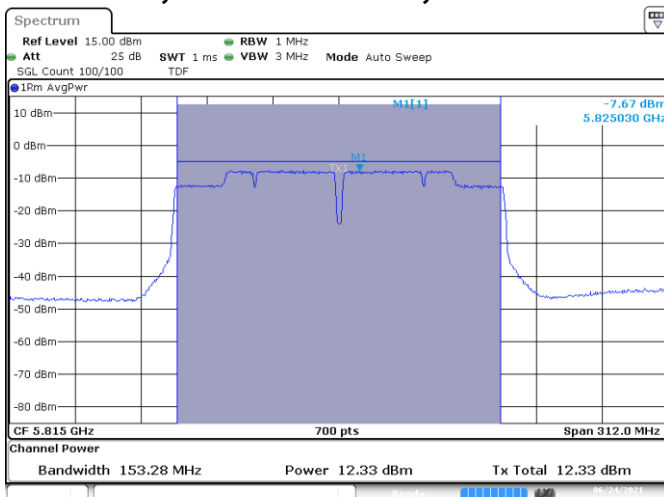

Date: 24.JUN.2021 21:54:29

SISO-A, 802.11ax20, HE0-CH-173

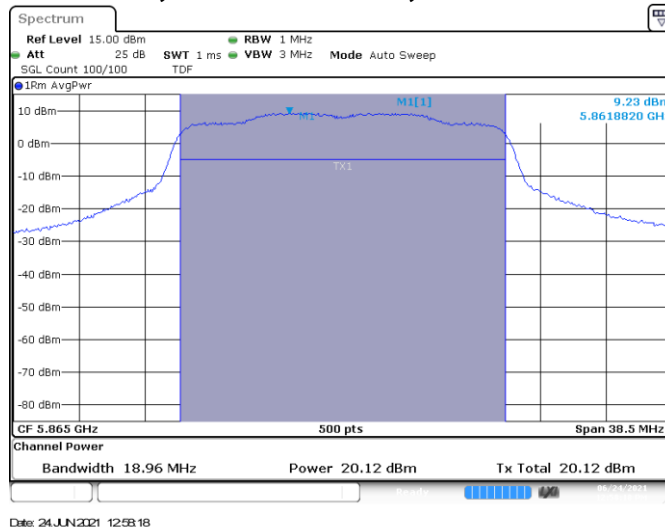

MIMO-A, 802.11ax40, HE0-CH167

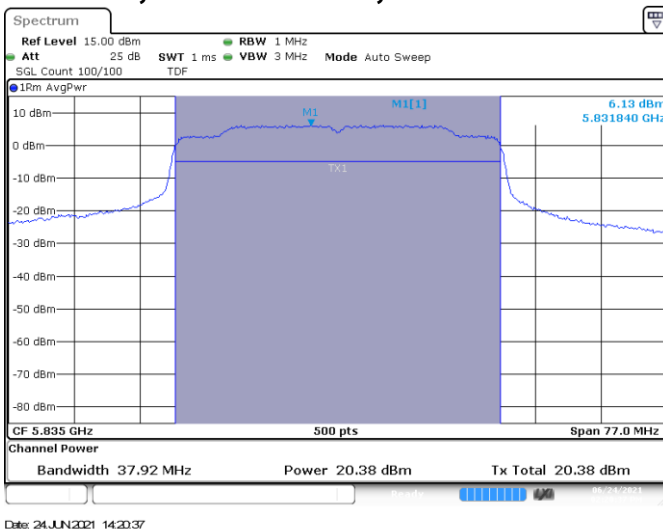

MIMO-B, 802.11ax40, HE0-CH167

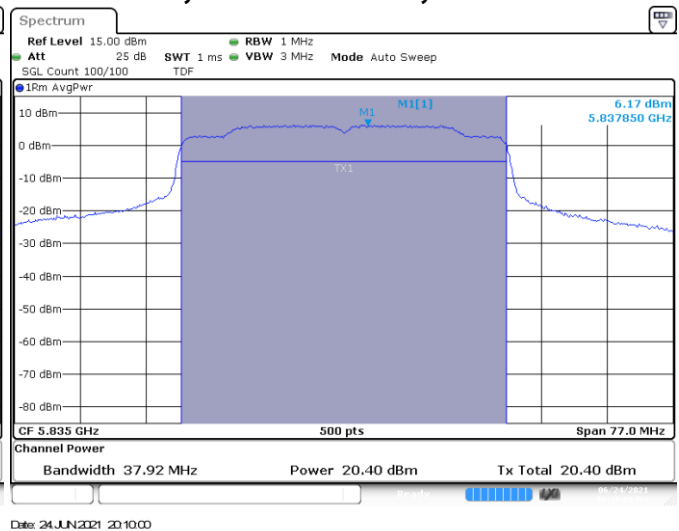

MIMO-A, 802.11ax80, HE0-CH171 MIMO-B, 802.11ax80, HE0-CH171

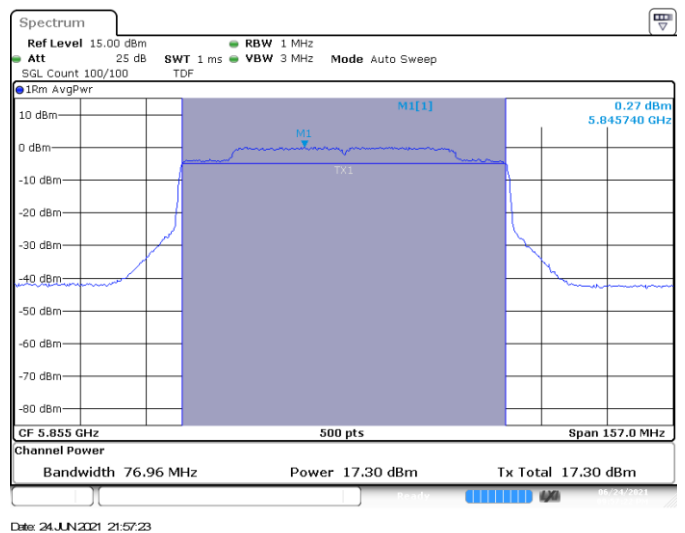
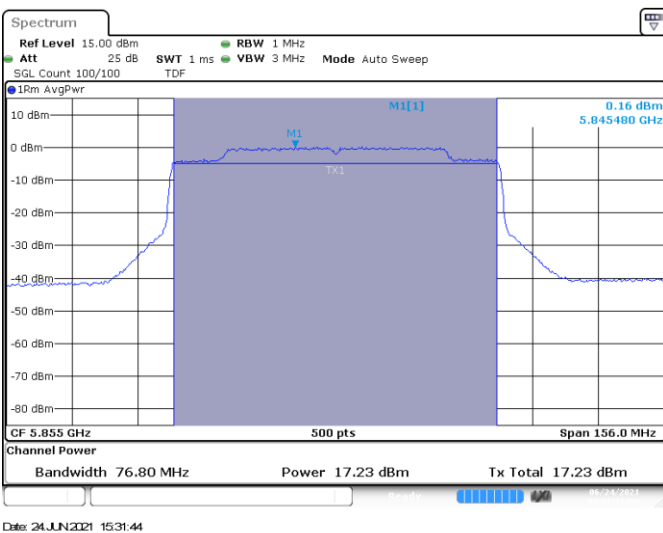

MIMO-A,802.11ax160,HE0-CH163

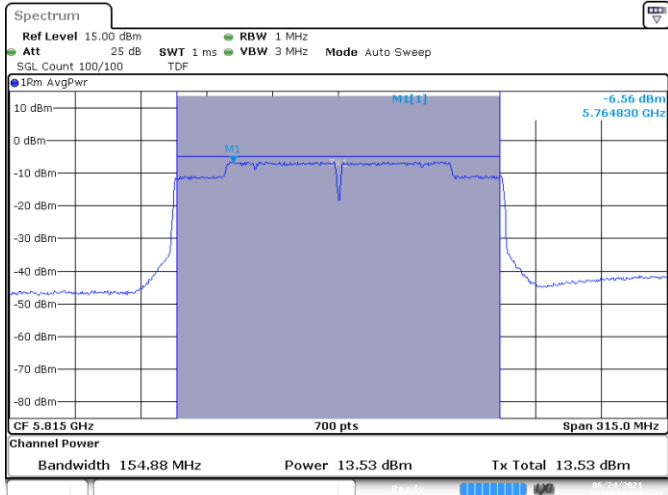

MIMO-B,802.11ax160,HE0-CH163

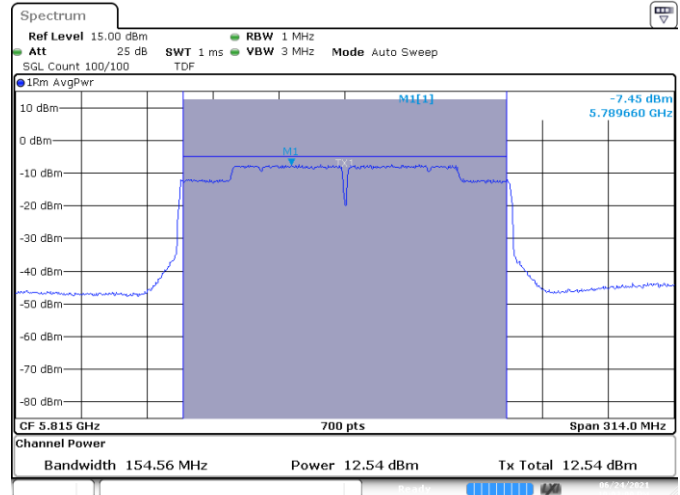

B.3.4 Maximum Power Spectral Density (PSD)

SISO-A, 802.11a, 6Mbps-CH-177

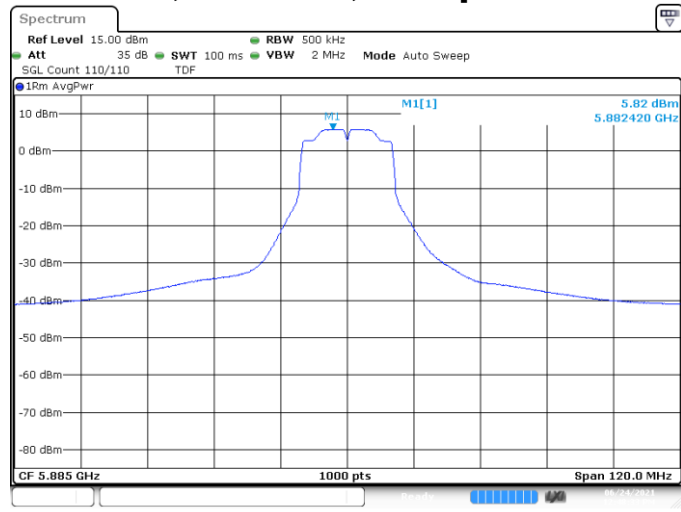

Date: 24.JUN.2021 12:48:34

MIMO-A, 802.11n20, HT8-CH-169 MIMO-B, 802.11n20, HT8-CH-169

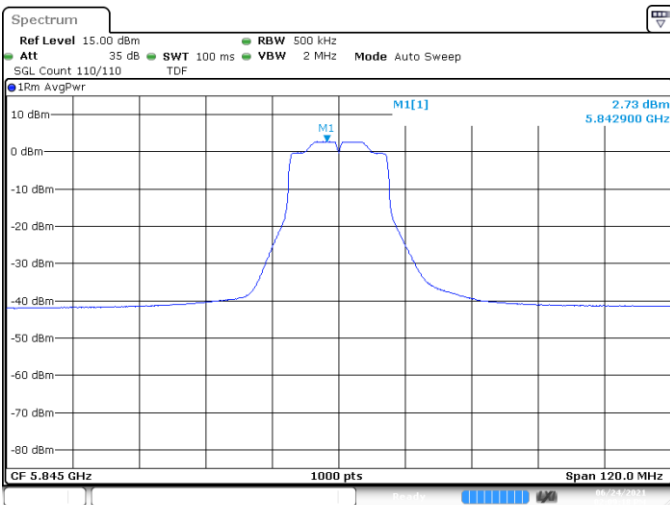

Date: 24.JUN.2021 14:09:19

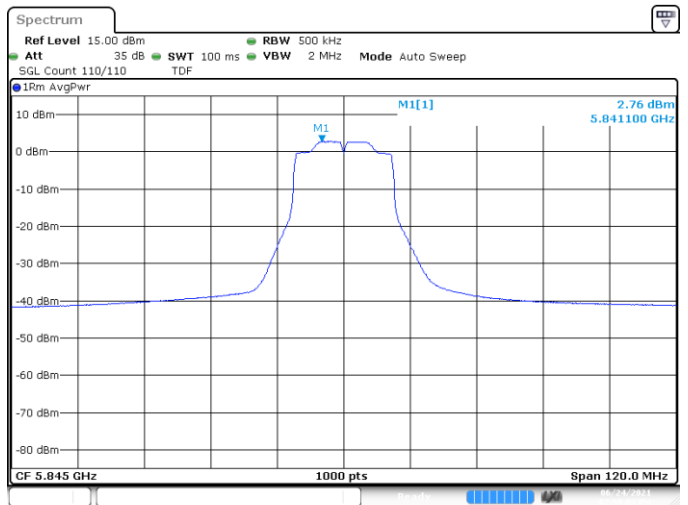

Date: 24.JUN.2021 19:59:03

MIMO-A, 802.11n40, HT8-CH-167

MIMO-B, 802.11n40, HT8-CH-167

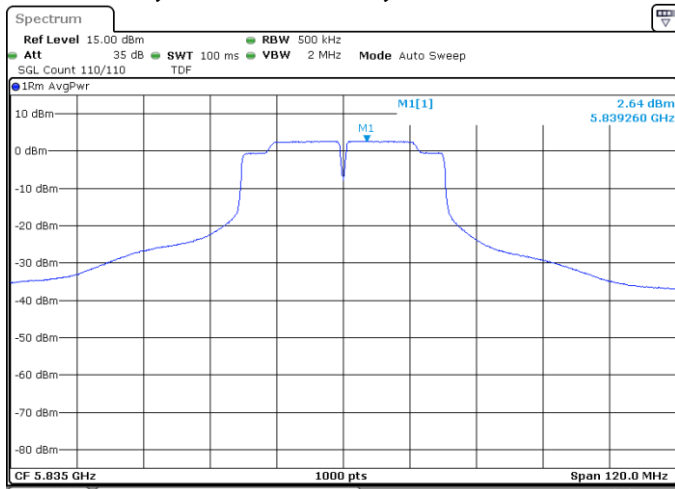

Date: 24.JUN.2021 14:12:40

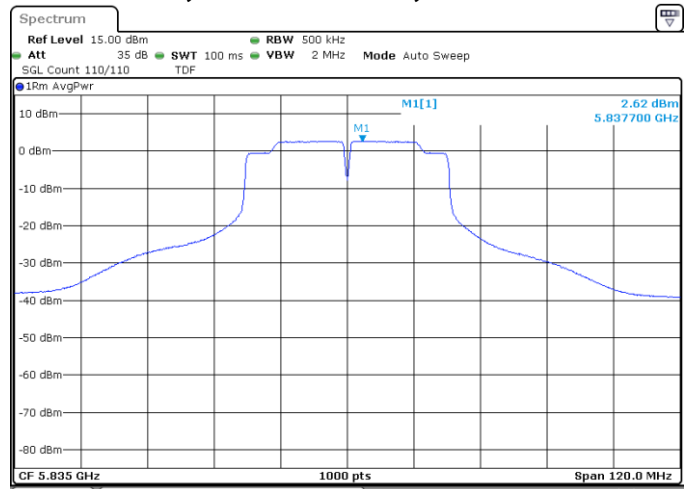

Date: 24.JUN.2021 20:02:23

MIMO-A,802.11ac80, VHT0-CH171

MIMO-B,802.11ac80, VHT0-CH171

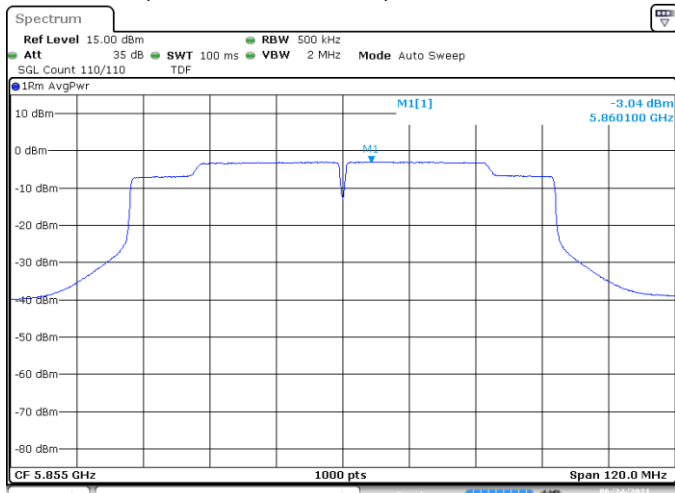

Date: 24.JUN.2021 15:12:19

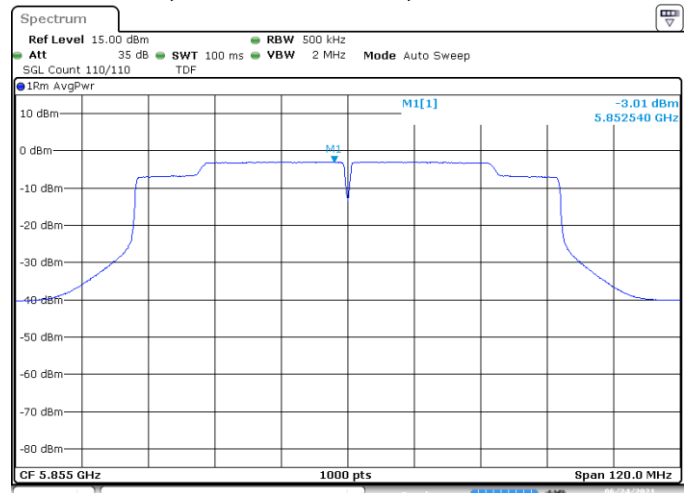

Date: 24.JUN.2021 21:48:32

MIMO-A,802.11ac160,VHT0-CH163 MIMO-B,802.11ac160,VHT0-CH163

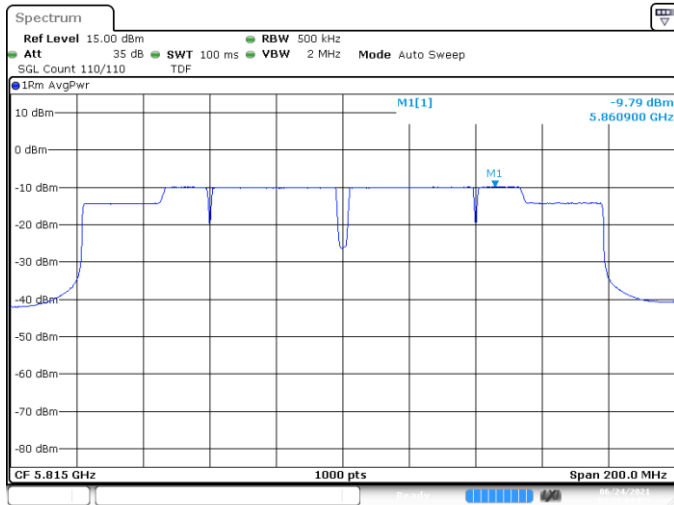

Date: 24.JUN.2021 15:19:04

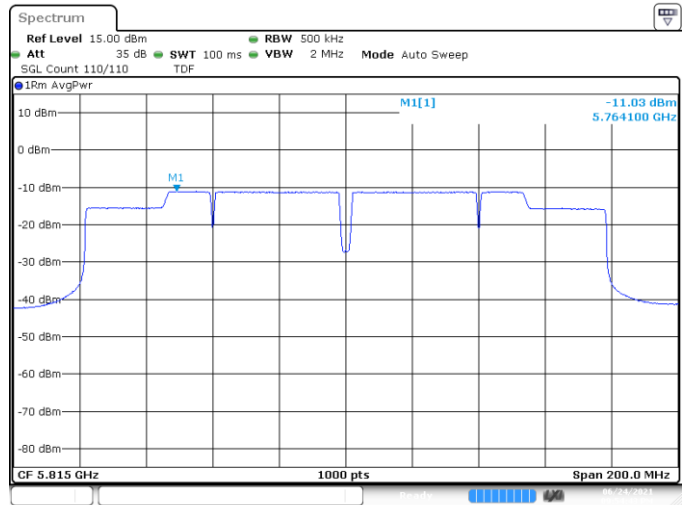

Date: 24.JUN.2021 21:54:43

SISO-A, 802.11ax20, HE0-CH-173

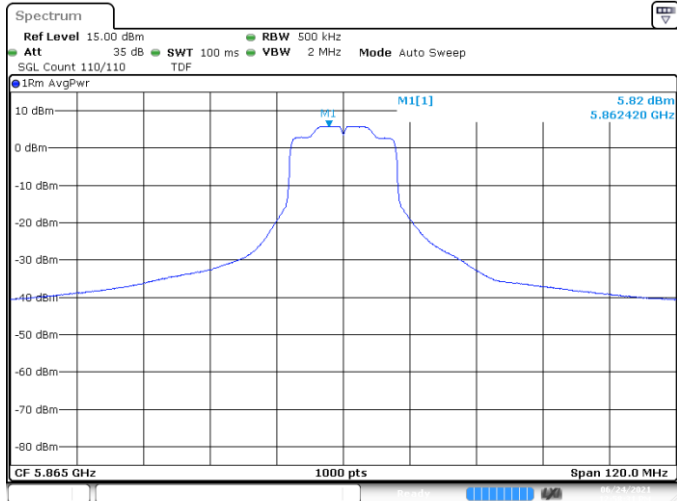

Date: 24.JUN.2021 12:58:32

MIMO-A, 802.11ax40, HE0-CH-167

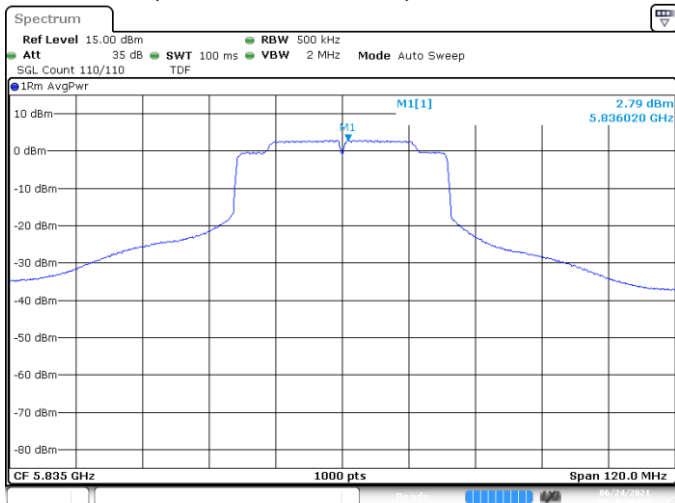

Date: 24.JUN.2021 14:20:50

MIMO-B, 802.11ax40, HE0-CH-167



Date: 24.JUN.2021 20:10:13

MIMO-A,802.11ax80,HE0-CH171

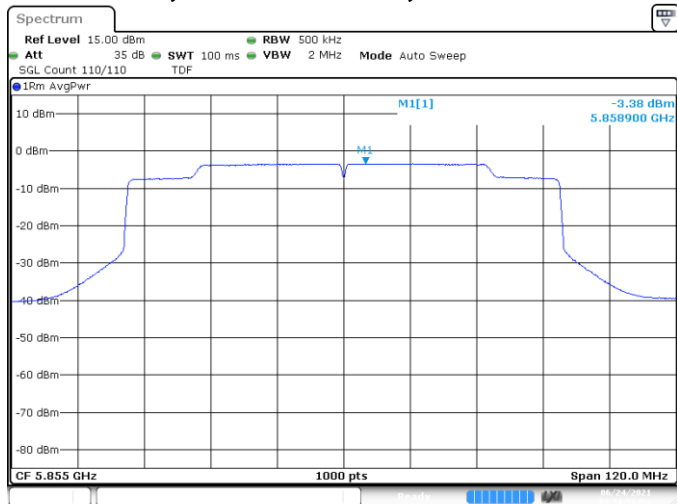

Date: 24.JUN.2021 15:31:58

MIMO-B,802.11ax80,HE0-CH171

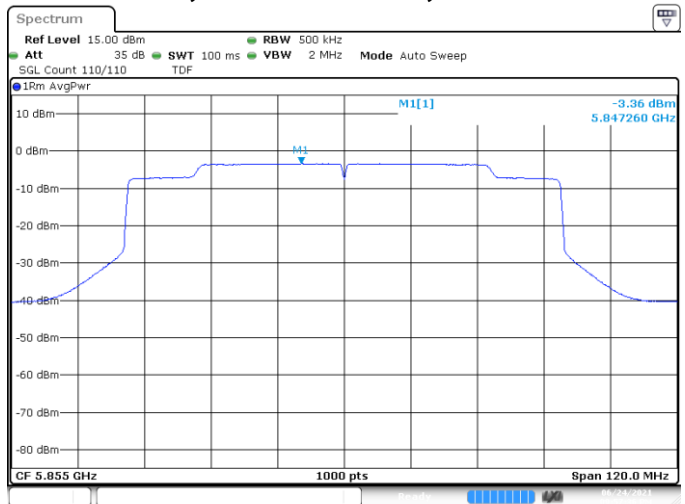

Date: 24.JUN.2021 21:57:36

MIMO-A,802.11ax160,HE0-CH163

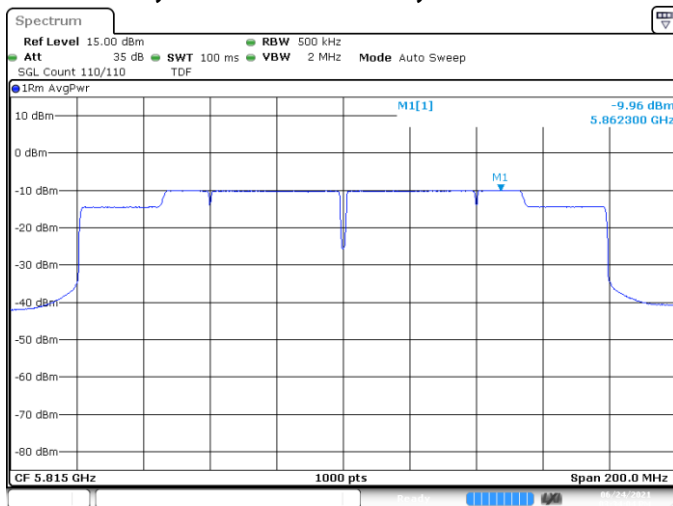

Date: 24.JUN.2021 15:34:04

MIMO-B,802.11ax160,HE0-CH163

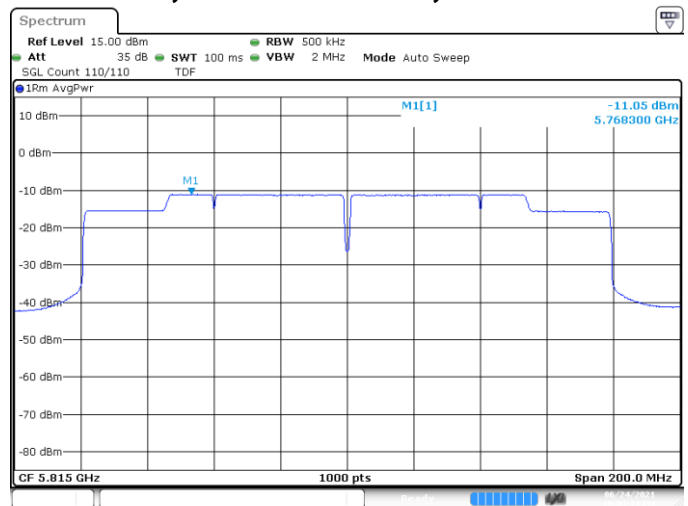

Date: 24.JUN.2021 22:03:14

B.3.5 Undesirable emission limits : out of band (Conducted)

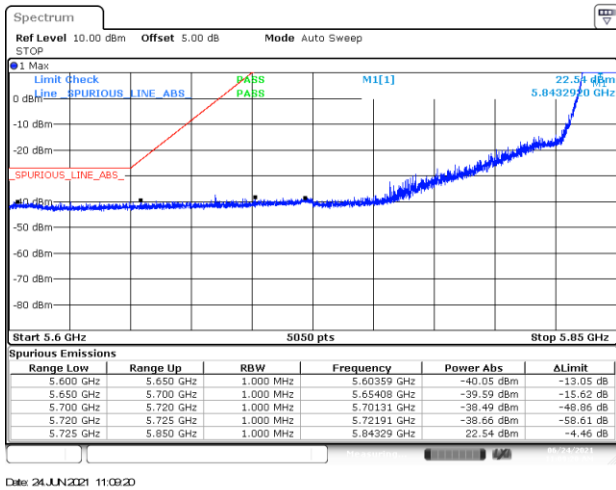

BE-NR-LOW, SISO-A, 802.11a20-6Mbps, Ch169

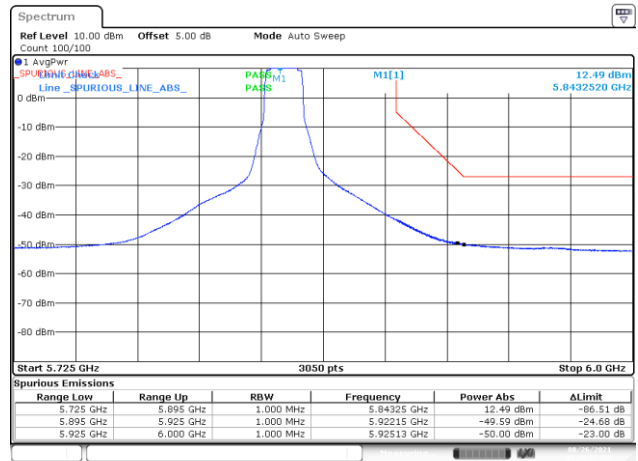

-BE-NR-HIGH, SISO-A, 802.11a20-6Mbps, Ch169

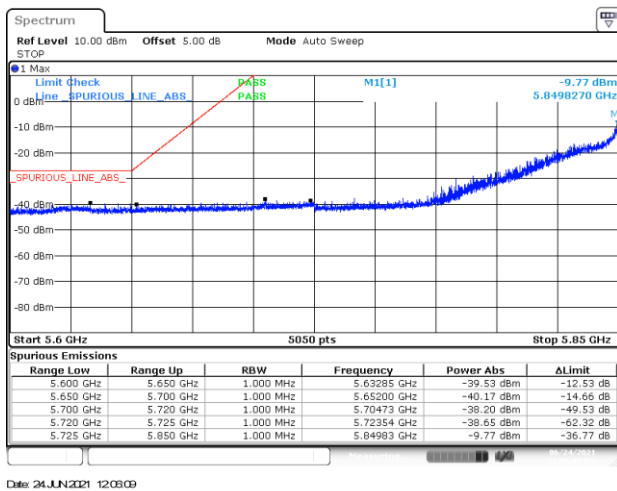

-BE-NR-LOW, SISO-A, 802.11a20-6Mbps, Ch173

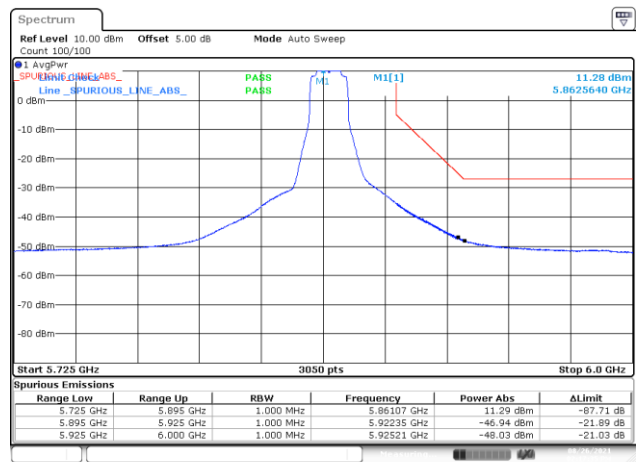

-BE-NR-HIGH, SISO-A, 802.11a20-6Mbps, Ch173

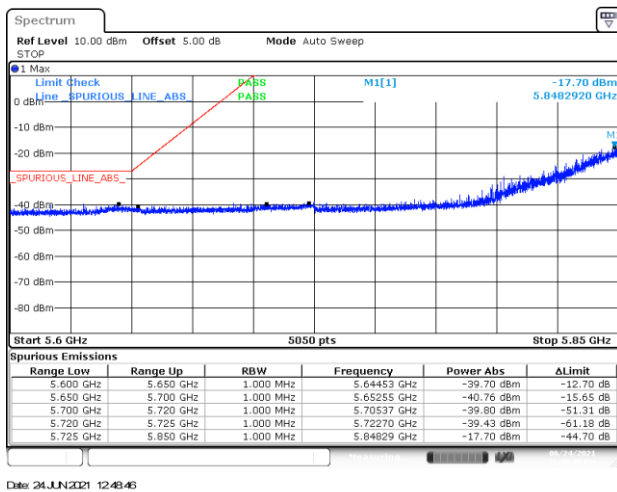

-BE-NR-LOW, SISO-A, 802.11a20-6Mbps, Ch177

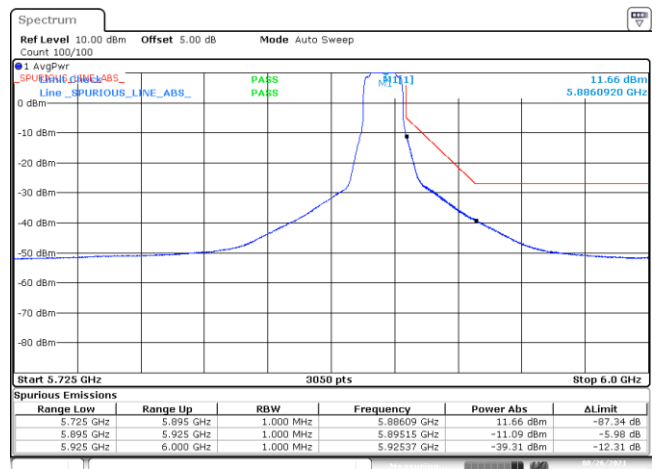

-BE-NR-HIGH, SISO-A, 802.11a20-6Mbps, Ch177

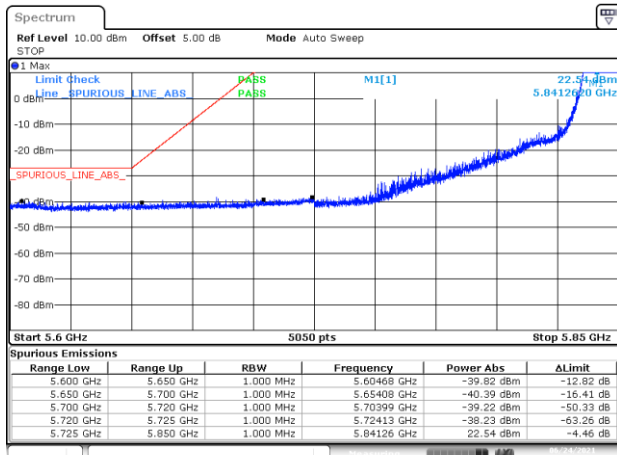

Date: 24.JUN.2021 12:49:52

-BE-NR-LOW, SISO-A, 802.11n20-HT0, Ch169

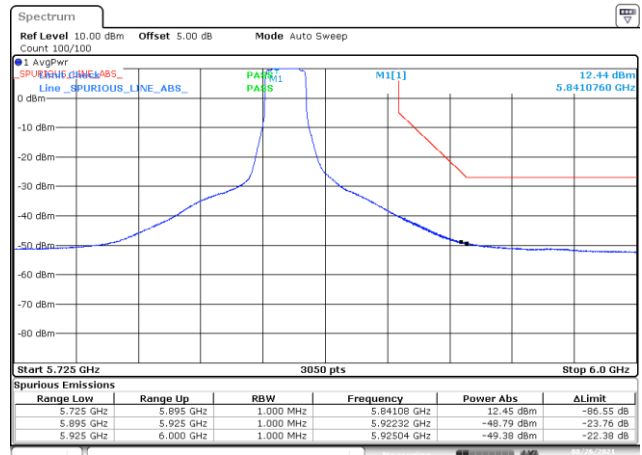

-BE-NR-HIGH, SISO-A, 802.11n20-HT0, Ch169

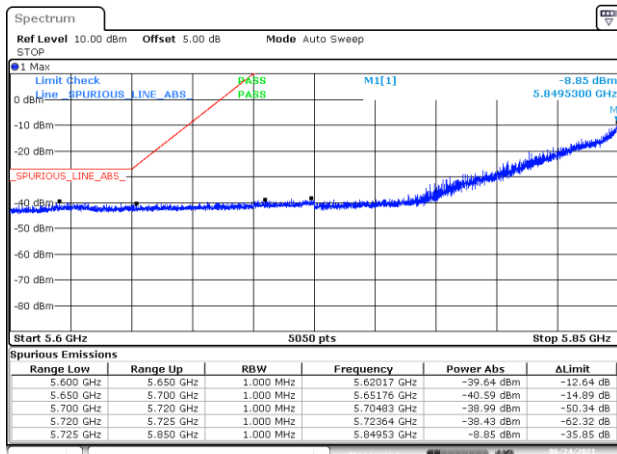

Date: 24.JUN.2021 12:50:58

-BE-NR-LOW, SISO-A, 802.11n20-HT0, Ch173

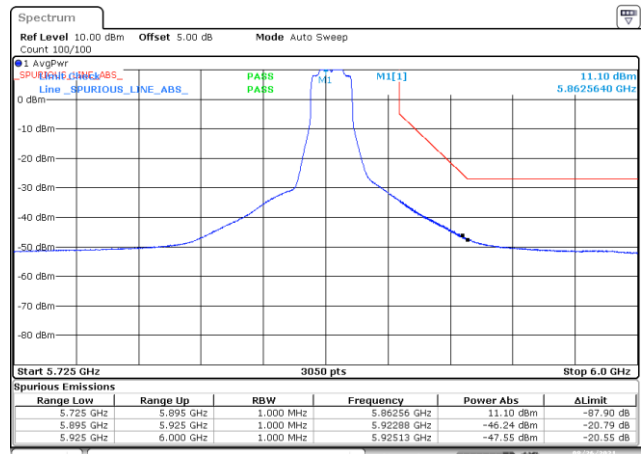

-BE-NR-HIGH SISO-A, 802.11n20-HT0, Ch173

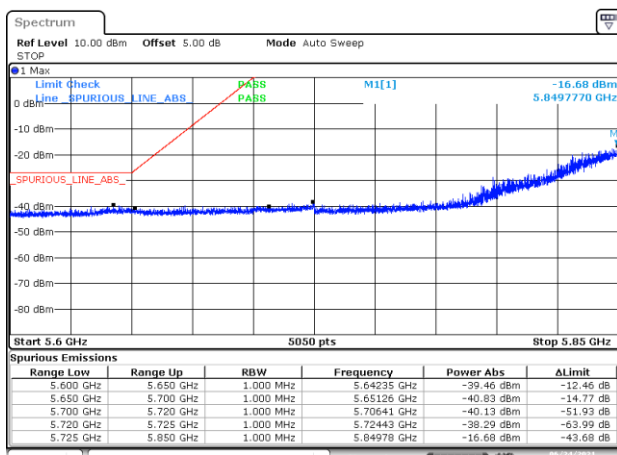

Date: 24.JUN.2021 12:52:04

-BE-NR-LOW, SISO-A, 802.11n20-HT0, Ch177

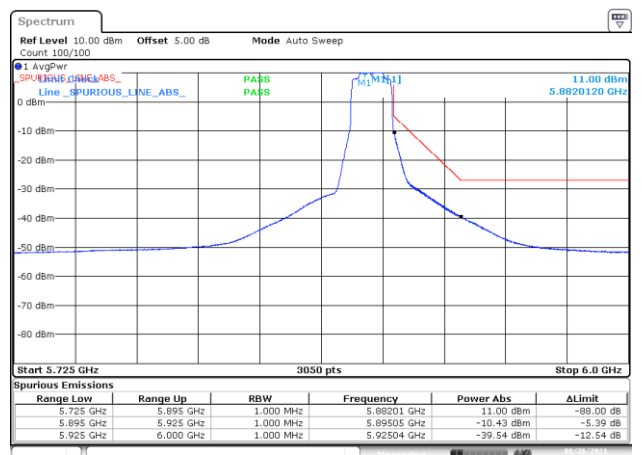

-BE-NR-HIGH, SISO-A, 802.11n20-HT0, Ch177

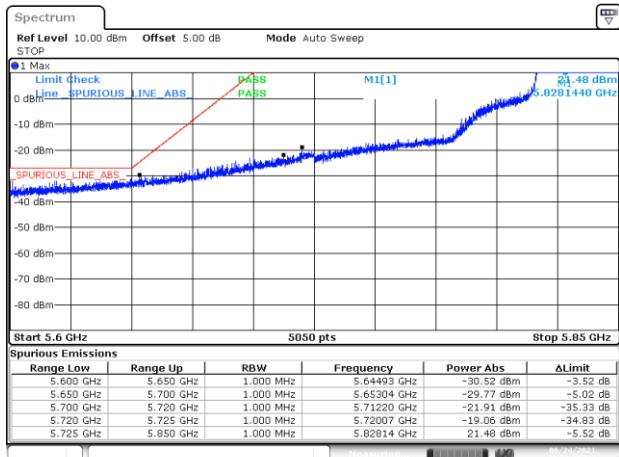

Date: 24.JUN.2021 12:53:10

-BE-NR-LOW, SISO-A, 802.11n40-HT0, Ch167

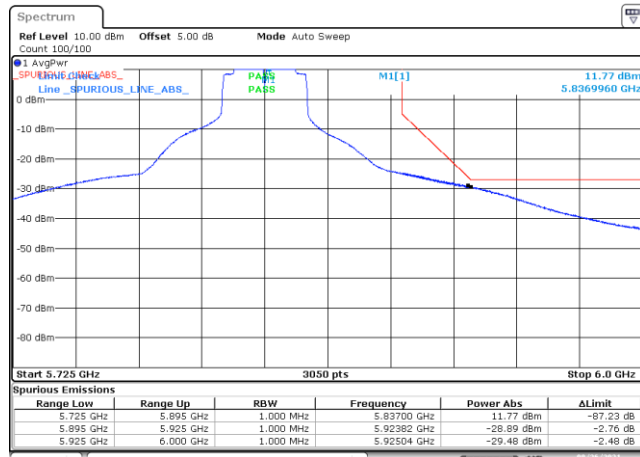

-BE-NR-HIGH, SISO-A, 802.11n40-HT0, Ch167

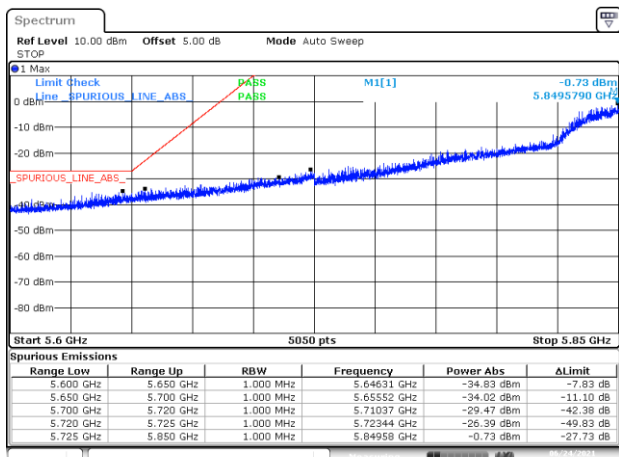

Date: 24.JUN.2021 15:59:45

-BE-NR-LOW, SISO-A, 802.11n40-HT0, Ch175

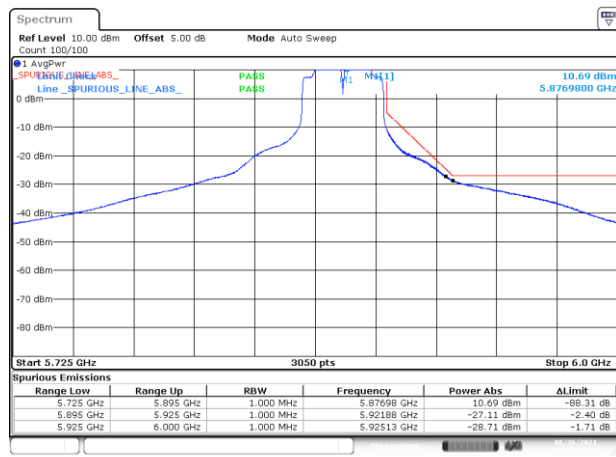

-BE-NR-HIGH, SISO-A, 802.11n40-HT0, Ch175

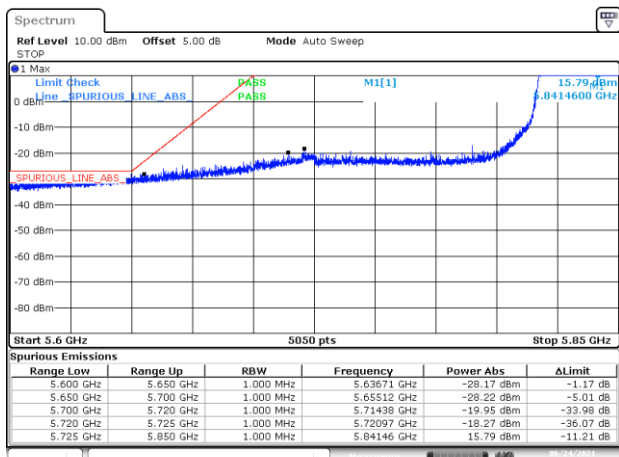

Date: 24.JUN.2021 16:08:31

-BE-NR-LOW, SISO-A, 802.11ac80-VHT0, Ch171

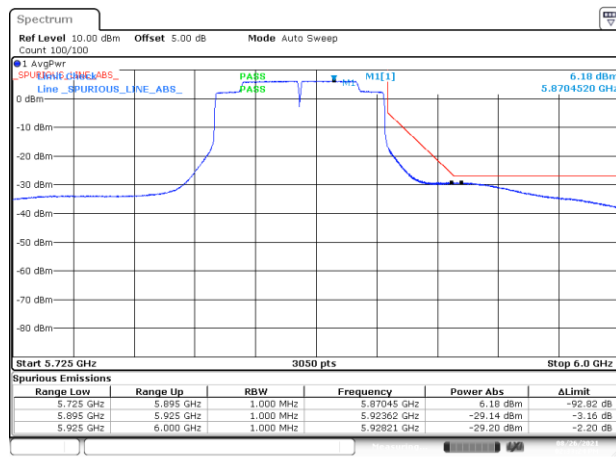

-BE-NR-HIGH, SISO-A, 802.11ac80-VHT0, Ch171

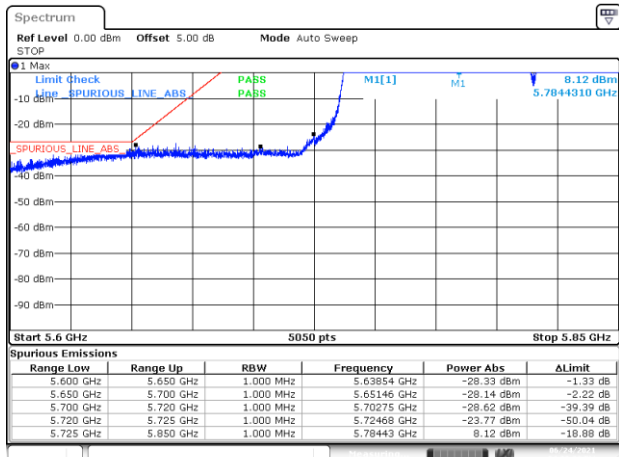

Date: 24.JUN.2021 16:03:23

-BE-NR-LOW, SISO-A, 802.11ac160-VHT0, Ch163

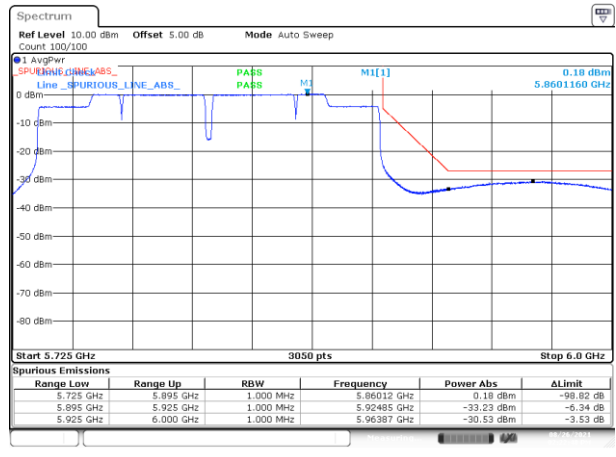

-BE-NR-HIGH, SISO-A, 802.11ac160-VHT0, Ch163

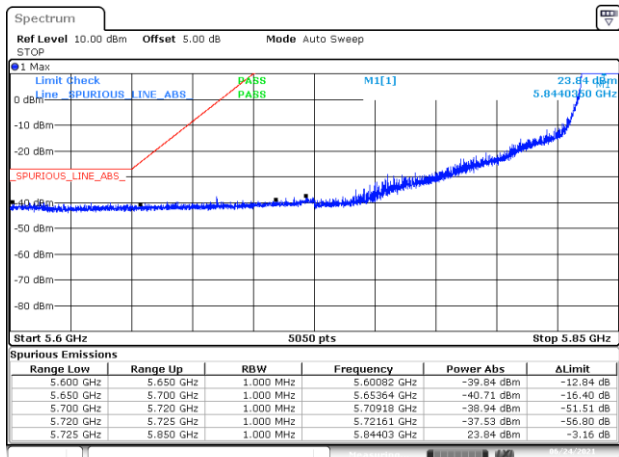

Date: 24.JUN.2021 12:57:37

-BE-NR-LOW, SISO-A, 802.11ax20-HE0, Ch169

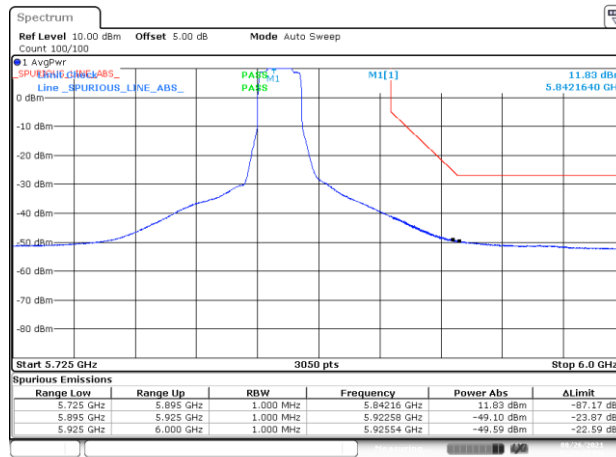

--BE-NR-HIGH, SISO-A, 802.11ax20-HE0, Ch169

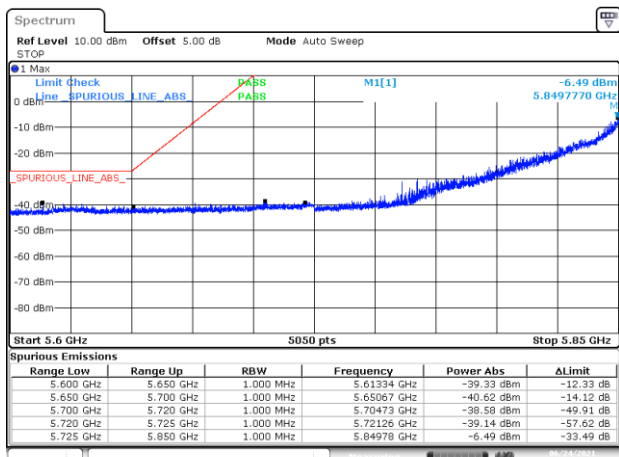

Date: 24.JUN.2021 12:58:43

-BE-NR-LOW, SISO-A, 802.11ax20-HE0, Ch173

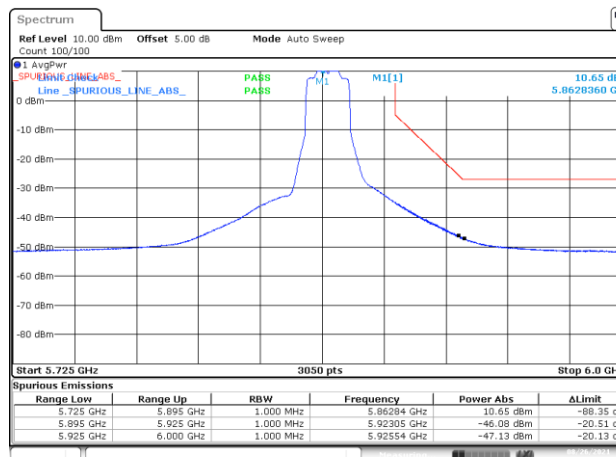

-BE-NR-HIGH, SISO-A, 802.11ax20-HE0, Ch173