



# FCC RF Test Report

APPLICANT : ASUSTeK COMPUTER INC.  
EQUIPMENT : ASUS Phone(Mobile Phone)  
BRAND NAME : ASUS  
MODEL NAME : ASUS\_AI2202  
FCC ID : MSQAI2202  
STANDARD : 47 CFR Part 2, Part 27 Subpart Q  
CLASSIFICATION : PCS Licensed Transmitter Held to Ear (PCE)  
TEST DATE(S) : May 23, 2022 ~ Aug. 22, 2022

We, Sporton International Inc. (ShenZhen), would like to declare that the tested sample has been evaluated in accordance with the procedures given in ANSI C63.26-2015 and shown compliance with the applicable technical standards.

This report contains data that were produced under subcontract by Sporton International Inc. (Kunshan).

The test results in this report apply exclusively to the tested model / sample. Without written approval of Sporton International Inc. (ShenZhen), the test report shall not be reproduced except in full.

Jason Jia



Approved by: Jason Jia

**Sporton International Inc. (ShenZhen)**

**1/F, 2/F, Bldg 5, Shiling Industrial Zone, Xinwei Village, Xili, Nanshan, Shenzhen, 518055**

**People's Republic of China**



TABLE OF CONTENTS

REVISION HISTORY..... 3
SUMMARY OF TEST RESULT ..... 4
1 GENERAL DESCRIPTION ..... 5
1.1 Applicant ..... 5
1.2 Manufacturer ..... 5
1.3 Product Feature of Equipment Under Test ..... 5
1.4 Product Specification of Equipment Under Test ..... 6
1.5 Modification of EUT ..... 6
1.6 Maximum EIRP Power and Emission Designator ..... 7
1.7 Testing Site ..... 8
1.8 Test Software ..... 8
1.9 Applied Standards ..... 9
2 TEST CONFIGURATION OF EQUIPMENT UNDER TEST ..... 10
2.1 Test Mode ..... 10
2.2 Connection Diagram of Test System ..... 11
2.3 Support Unit used in test configuration and system ..... 11
2.4 Measurement Results Explanation Example ..... 11
2.5 Frequency List of Low/Middle/High Channels ..... 12
3 CONDUCTED TEST ITEMS ..... 13
3.1 Measuring Instruments ..... 13
3.2 Test Setup ..... 13
3.3 Test Result of Conducted Test ..... 13
3.4 Conducted Output Power Measurement ..... 14
3.5 Peak-to-Average Ratio ..... 15
3.6 EIRP ..... 16
3.7 Occupied Bandwidth ..... 17
3.8 Conducted Band Edge Measurement ..... 18
3.9 Conducted Spurious Emission Measurement ..... 19
3.10 Frequency Stability Measurement ..... 20
4 RADIATED TEST ITEMS ..... 21
4.1 Measuring Instruments ..... 21
4.2 Test Setup ..... 21
4.3 Test Result of Radiated Test ..... 22
4.4 Radiated Spurious Emission Measurement ..... 23
5 LIST OF MEASURING EQUIPMENT ..... 24
6 UNCERTAINTY OF EVALUATION ..... 26
APPENDIX A. TEST RESULTS OF CONDUCTED TEST
APPENDIX B. TEST RESULTS OF RADIATED TEST
APPENDIX C. TEST SETUP PHOTOGRAPHS



## SUMMARY OF TEST RESULT

Report Section	FCC Rule	Description	Limit	Result	Remark
3.4	§2.1046	Conducted Output Power	—	Report Only	-
3.5	§27.50 (k)(4)	Peak-to-Average Ratio	<13dB	PASS	
3.6	§27.50 (k)(3)	EIRP	EIRP < 1W (30dBm)	PASS	-
3.7	§2.1049	Occupied Bandwidth	—	Report Only	-
3.8	§2.1051 §27.53 (n)(2)	Conducted Band Edge Measurement	-13dBm/MHz	PASS	-
3.9	§2.1051 §27.53 (n)(2)	Conducted Spurious Emission	-13dBm/MHz	PASS	-
3.10	§2.1055 §27.54	Frequency Stability Temperature & Voltage	Within the band	PASS	-
4.4	§2.1053 §27.53 (n)(2)	Radiated Spurious Emission	-13dBm/MHz	PASS	Under limit 38.93 dB at 13800.000 MHz

<b>Declaration of Conformity:</b>
The test results with all measurement uncertainty excluded are presented in accordance with the regulation limits or requirements declared by manufacturers.
<b>Comments and Explanations:</b>
The declared of product specification for EUT presented in the report are provided by the manufacturer, and the manufacturer takes all the responsibilities for the accuracy of product specification.



# 1 General Description

## 1.1 Applicant

**ASUSTeK COMPUTER INC.**

1F., No. 15, Lide Rd., Beitou Dist., Taipei City 112, Taiwan

## 1.2 Manufacturer

**ASUSTeK COMPUTER INC.**

1F., No. 15, Lide Rd., Beitou Dist., Taipei City 112, Taiwan

## 1.3 Product Feature of Equipment Under Test

Product Feature	
Equipment	ASUS Phone(Mobile Phone)
Brand Name	ASUS
Model Name	ASUS_AI2202
FCC ID	MSQAI2202
IMEI Code	Conducted : 355316920101376 Radiation : 354283690001593/354283690001601
HW Version	AI2202_MB_ER2 R2.0
SW Version	Android R
EUT Stage	Production Unit

### 1.4 Product Specification of Equipment Under Test

Product Feature	
<b>Tx/Rx Frequency</b>	5G NR n77: 3450 MHz ~ 3550 MHz 5G NR n78: 3450 MHz ~ 3550 MHz
<b>Bandwidth</b>	10MHz / 15MHz / 20MHz / 30MHz / 40MHz / 50MHz / 60MHz / 70MHz / 80MHz / 90MHz / 100MHz
<b>SCS</b>	30kHz
<b>Antenna Gain</b>	<b>&lt;Ant. 2&gt;</b> 5G NR n77 : -5.04 dBi 5G NR n78 : -5.04 dBi <b>&lt;Ant. 4&gt;</b> 5G NR n77 : -4.98 dBi 5G NR n78 : -4.98 dBi <b>&lt;Ant. 5&gt;</b> 5G NR n77 : -5.39 dBi 5G NR n78 : -5.39 dBi <b>&lt;Ant. 6&gt;</b> 5G NR n77 : -4.95 dBi 5G NR n78 : -4.95 dBi
<b>Type of Modulation</b>	CP-OFDM: QPSK / 16QAM / 64QAM / 256QAM DFT-s-OFDM: PI/2 BPSK / QPSK / 16QAM / 64QAM / 256QAM

**Remark:**

1. The maximum EIRP is calculated from max output power and max antenna gain, only the maximum EIRP of Antenna 5 is shown in the report.
2. 5G NR n77/n78 supports SA and NSA mode. According to the maximum power, SA covers NSA mode and 5G NR n77 covers 5G NR n78.
3. The EN-DC mode combination could be referred to the product spec.

### 1.5 Modification of EUT

No modifications are made to the EUT during all test items.

## 1.6 Maximum EIRP Power and Emission Designator

5G NR n77		PI/2 BPSK/QPSK		16QAM/64QAM/256QAM	
BW (MHz)	Frequency Range (MHz)	Maximum EIRP(W)	Emission Designator (99%OBW)	Maximum EIRP(W)	Emission Designator (99%OBW)
10	3455.01 ~ 3544.98	0.0624	8M62G7D	0.0497	8M60W7D
15	3457.50 ~ 3542.49	0.0652	13M6G7D	0.0525	13M6W7D
20	3460.02 ~ 3540.00	0.0638	18M2G7D	0.0500	18M3W7D
30	3465.00 ~ 3534.99	0.0684	27M9G7D	0.0536	27M9W7D
40	3470.01 ~ 3529.98	0.0679	37M8G7D	0.0565	37M9W7D
50	3475.02 ~ 3525.00	0.0661	47M5G7D	0.0488	47M6W7D
60	3480.00 ~ 3519.99	0.0634	57M9G7D	0.0524	57M9W7D
70	3485.01 ~ 3514.98	0.0617	67M5G7D	0.0482	67M5W7D
80	3490.02 ~ 3510.00	0.0565	77M6G7D	0.0441	77M6W7D
90	3495.00 ~ 3504.99	0.0547	87M6G7D	0.0446	87M7W7D
100	3500.01	0.0697	97M6G7D	0.0485	97M6W7D
5G NR n78		PI/2 BPSK/QPSK		16QAM/64QAM/256QAM	
BW (MHz)	Frequency Range (MHz)	Maximum EIRP(W)	Emission Designator (99%OBW)	Maximum EIRP(W)	Emission Designator (99%OBW)
10	3455.01 ~ 3544.98	0.0640	8M62G7D	0.0519	8M60W7D
15	3457.50 ~ 3542.49	0.0643	13M6G7D	0.0526	13M6W7D
20	3460.02 ~ 3540.00	0.0643	18M2G7D	0.0492	18M3W7D
30	3465.00 ~ 3534.99	0.0667	27M9G7D	0.0535	27M9W7D
40	3470.01 ~ 3529.98	0.0679	37M8G7D	0.0571	37M9W7D
50	3475.02 ~ 3525.00	0.0652	47M5G7D	0.0532	47M6W7D
60	3480.00 ~ 3519.99	0.0632	57M9G7D	0.0521	57M9W7D
70	3485.01 ~ 3514.98	0.0589	67M5G7D	0.0470	67M5W7D
80	3490.02 ~ 3510.00	0.0562	77M6G7D	0.0459	77M6W7D
90	3495.00 ~ 3504.99	0.0550	87M6G7D	0.0446	87M7W7D
100	3500.01	0.0681	97M6G7D	0.0484	97M6W7D

**Note:**

- 5G NR Band n77 overlaps the entire frequency range of Band n78 for Part 27 Subpart Q. Therefore, the test results of conducted test items provided in this report covers Band n77 as well as Band n78.
- All modulations have been evaluation, only the worst test results of PSK & QAM are shown in the report.

## 1.7 Testing Site

Sporton International Inc. (Shenzhen) is accredited to ISO/IEC 17025:2017 by American Association for Laboratory Accreditation with Certificate Number 5145.01.

<b>Test Firm</b>	Sporton International Inc. (Shenzhen)		
<b>Test Site Location</b>	1/F, 2/F, Bldg 5, Shiling Industrial Zone, Xinwei Village, Xili, Nanshan, Shenzhen, 518055 People's Republic of China TEL: +86-755-86379589 FAX: +86-755-86379595		
<b>Test Site No.</b>	<b>Sporton Site No.</b>	<b>FCC Designation No.</b>	<b>FCC Test Firm Registration No.</b>
	TH01-SZ	CN1256	421272

<b>Test Firm</b>	Sporton International Inc. (Shenzhen)		
<b>Test Site Location</b>	101, 1st Floor, Block B, Building 1, No. 2, Tengfeng 4th Road, Fenghuang Community, Fuyong Street, Baoan District, Shenzhen City Guangdong Province China 518103 TEL: +86-755-33202398		
<b>Test Site No.</b>	<b>Sporton Site No.</b>	<b>FCC Designation No.</b>	<b>FCC Test Firm Registration No.</b>
	03CH03-SZ	CN1256	421272

Sporton International Inc. (Kunshan) is accredited to ISO/IEC 17025:2017 by American Association for Laboratory Accreditation with Certificate Number 5145.02.

<b>Test Firm</b>	Sporton International Inc. (Kunshan)		
<b>Test Site Location</b>	No. 1098, Pengxi North Road, Kunshan Economic Development Zone Jiangsu Province 215300 People's Republic of China TEL : +86-512-57900158 FAX : +86-512-57900958		
<b>Test Site No.</b>	<b>Sporton Site No.</b>	<b>FCC Designation No.</b>	<b>FCC Test Firm Registration No.</b>
	03CH04-KS	CN1257	314309

Test data subcontracted: Radiated Spurious Emission test items in section 4.4 of this report.

## 1.8 Test Software

Item	Site	Manufacturer	Name	Version
1.	03CH04-KS	AUDIX	E3	6.2009-8-24a
2.	03CH03-SZ	AUDIX	E3	6.2009-8-24





## 1.9 Applied Standards

According to the specifications of the manufacturer, the EUT must comply with the requirements of the following standards:

- ♦ 47 CFR Part 2, Part 27 Subpart Q
- ♦ ANSI C63.26-2015
- ♦ FCC KDB 971168 Power Meas License Digital Systems D01 v03r01
- ♦ FCC KDB 412172 D01 Determining ERP and EIRP v01r01

### Remark:

1. All test items were verified and recorded according to the standards and without any deviation during the test.
2. This EUT has also been tested and complied with the requirements of FCC Part 15, Subpart B, recorded in a separate test report.

## 2 Test Configuration of Equipment Under Test

### 2.1 Test Mode

Antenna port conducted and radiated test items listed below are performed according to KDB 971168 D01 Power Meas. License Digital Systems v03r01 with maximum output power.

Radiated measurements are performed by rotating the EUT in three different orthogonal test planes to find the maximum emission.

Test Cases	Band	Bandwidth (MHz)	Modulation	RB #	Test Channel
		eg. 5M, 10M, 15M, 20M	eg. QPSK, 16QAM, 64QAM	1RB, Partial RB, Full RB	L/M/H
Max. Output Power	5G n77	10M, 15M, 20M, 30M, 40M, 50M, 60M, 70M, 80M, 90M, 100M	PI/2 BPSK, QPSK, 16QAM, 64QAM, 256QAM	1RB, Partial RB, Full RB	L, M, H
	5G n78	10M, 15M, 20M, 30M, 40M, 50M, 60M, 70M, 80M, 90M, 100M	PI/2 BPSK, QPSK, 16QAM, 64QAM, 256QAM	1RB, Partial RB, Full RB	L, M, H
Peak-to-Average Ratio	5G n77	20M	PI/2 BPSK, QPSK	1RB, Full RB	L, M, H
E.I.R.P	5G n77	10M, 15M, 20M, 30M, 40M, 50M, 60M, 70M, 80M, 90M, 100M	PI/2 BPSK, QPSK, 16QAM, 64QAM, 256QAM	1RB, Partial RB, Full RB	L, M, H
	5G n78	10M, 15M, 20M, 30M, 40M, 50M, 60M, 70M, 80M, 90M, 100M	PI/2 BPSK, QPSK, 16QAM, 64QAM, 256QAM	1RB, Partial RB, Full RB	L, M, H
26dB and 99% Bandwidth	5G n77	10M, 15M, 20M, 30M, 40M, 50M, 60M, 70M, 80M, 90M, 100M	PI/2 BPSK, QPSK, 16QAM, 64QAM, 256QAM	Full RB	M
Conducted Band Edge	5G n77	10M, 50M, 100M	PI/2 BPSK, QPSK	1RB, Full RB	L, H
Conducted Spurious Emission	5G n77	10M, 50M, 100M	PI/2 BPSK, QPSK	1RB	L, M, H
Frequency Stability	5G n77	20M	QPSK	Full RB	M
Radiated Spurious Emission	5G n77	Worst case from maximum power			M

**Note:**

1. The device is investigated from 30MHz to 10 times of fundamental signal for radiated spurious emission test under different RB size/offset and modulations in exploratory test. Subsequently, only the worst case emissions are reported.
2. Based on engineering evaluation, only the worst modulations test results are shown in the report.
3. The n77 conducted and RSE test results cover n78 in this report.
4. Frequency Stability: Normal Voltage = 3.89V ; Low Voltage =3.65V.; High Voltage =4.35V

## 2.2 Connection Diagram of Test System

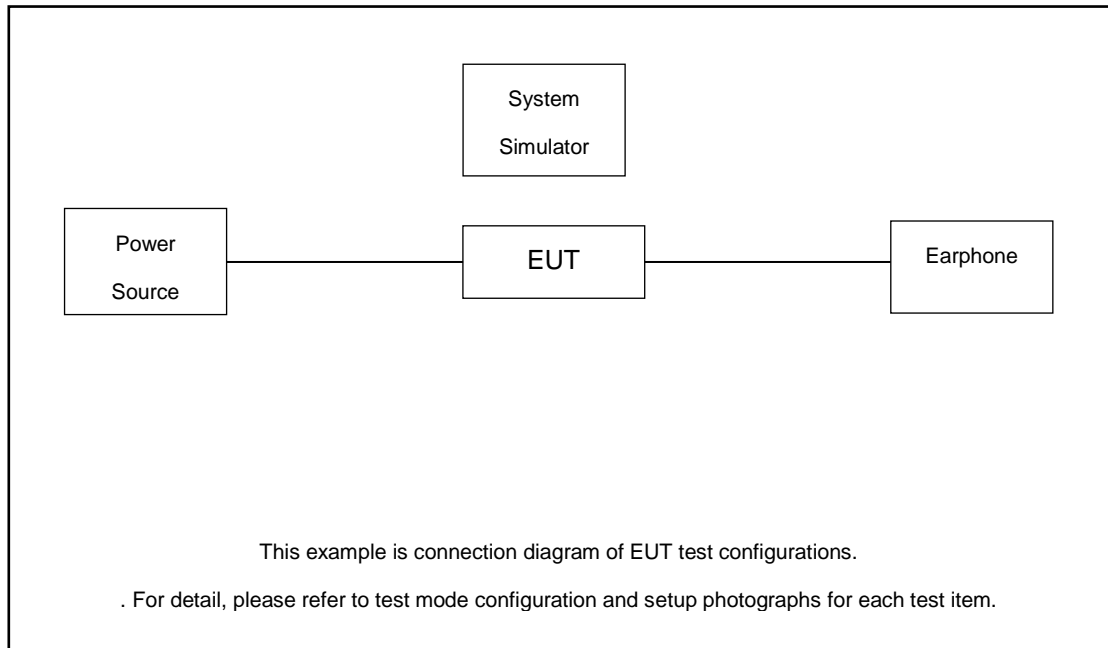

## 2.3 Support Unit used in test configuration and system

Item	Equipment	Trade Name	Model No.	FCC ID	Data Cable	Power Cord
1.	DC Power Supply	GW	GPS-3030D	N/A	N/A	Unshielded, 1.8 m
2.	Base Station	Anritsu	MT8820/8821	N/A	N/A	Unshielded,1.8m

## 2.4 Measurement Results Explanation Example

### For all conducted test items:

The offset level is set in the spectrum analyzer to compensate the RF cable loss and attenuator factor between EUT conducted output port and spectrum analyzer. With the offset compensation, the spectrum analyzer reading level is exactly the EUT RF output level.

The spectrum analyzer offset is derived from RF cable loss and attenuator factor.

*Offset = RF cable loss + attenuator factor.*

Following shows an offset computation example with cable loss 5.58 dB and 10dB attenuator.

Example :

$$\begin{aligned} \text{Offset(dB)} &= \text{RF cable loss(dB)} + \text{attenuator factor(dB)}. \\ &= 5.58 + 10 = 15.58 \text{ (dB)} \end{aligned}$$



### 2.5 Frequency List of Low/Middle/High Channels

5G n77/n78 Channel and Frequency List				
BW [MHz]	Channel/Frequency(MHz)	Lowest	Middle	Highest
100	Channel	-	633334	-
	Frequency	-	3500.01	-
90	Channel	633000	633334	633666
	Frequency	3495	3500.01	3504.99
80	Channel	632668	633334	634000
	Frequency	3490.02	3500.01	3510
70	Channel	632334	633334	634332
	Frequency	3485.01	3500.01	3514.98
60	Channel	632000	633334	634666
	Frequency	3480	3500.01	3519.99
50	Channel	631668	633334	635000
	Frequency	3475.02	3500.01	3525
40	Channel	631334	633334	635332
	Frequency	3470.01	3500.01	3529.98
30	Channel	631000	633334	635666
	Frequency	3465	3500.01	3534.99
20	Channel	630668	633334	636000
	Frequency	3460.02	3500.01	3540
15	Channel	630500	633334	636166
	Frequency	3457.5	3500.01	3542.49
10	Channel	630334	633334	636332
	Frequency	3455.01	3500.01	3544.98

### 3 Conducted Test Items

#### 3.1 Measuring Instruments

See list of measuring instruments of this test report.

#### 3.2 Test Setup

##### 3.2.1 Conducted Output Power

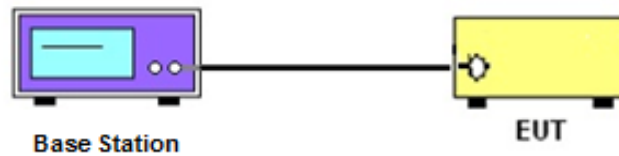

##### 3.2.2 Peak-to-Average Ratio, Occupied / 26dB Bandwidth , Band-Edge and Conducted Spurious Emission

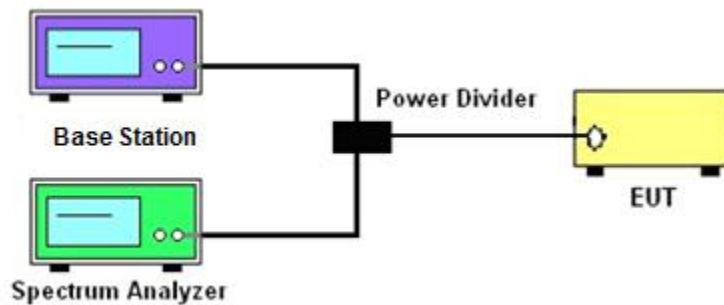

##### 3.2.3 Frequency Stability

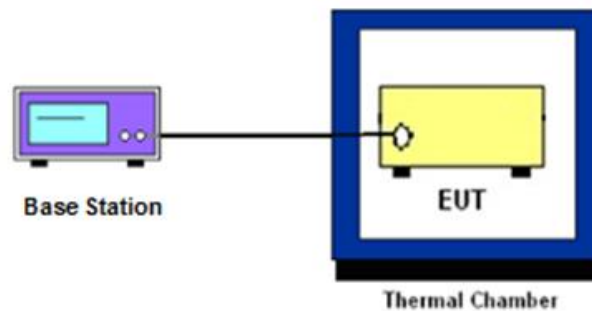

### 3.3 Test Result of Conducted Test

Please refer to Appendix A.



## 3.4 Conducted Output Power Measurement

### 3.4.1 Description of the Conducted Output Power Measurement

A base station simulator was used to establish communication with the EUT. Its parameters were set to transmit the maximum power on the EUT. The measured power in the radio frequency on the transmitter output terminals shall be reported.

### 3.4.2 Test Procedures

1. The testing follows ANSI C63.26 Section 5.2
2. The transmitter output port was connected to the system simulator.
3. Set EUT at maximum power through the system simulator.
4. Select lowest, middle, and highest channels for each band and different modulation.
5. Measure and record the power level from the system simulator.

## 3.5 Peak-to-Average Ratio

### 3.5.1 Description of the PAR Measurement

Power Complementary Cumulative Distribution Function (CCDF) curves provide a means for characterizing the power peaks of a digitally modulated signal on a statistical basis. A CCDF curve depicts the probability of the peak signal amplitude exceeding the average power level. Most contemporary measurement instrumentation include the capability to produce CCDF curves for an input signal provided that the instrument's resolution bandwidth can be set wide enough to accommodate the entire input signal bandwidth. In measuring transmissions in this band using an average power technique, the peak-to-average ratio (PAR) of the transmission may not exceed 13 dB.

### 3.5.2 Test Procedures

1. The testing follows ANSI C63.26 Section 5.2.3.4 (CCDF).
2. The EUT was connected to spectrum and system simulator via a power divider.
3. Set the CCDF (Complementary Cumulative Distribution Function) option in spectrum analyzer.
4. The highest RF powers were measured and recorded the maximum PAPR level associated with a probability of 0.1 %.
5. Record the deviation as Peak to Average Ratio.

## 3.6 EIRP

### 3.6.1 Description of EIRP Limit

#### § 27.50 (k)(3)

Mobile devices are limited to 1Watt (30 dBm) EIRP. Mobile devices operating in these bands must employ a means for limiting power to the minimum necessary for successful communications

### 3.6.2 Test Procedures

1. According to KDB 412172 D01 Power Approach,
2.  $EIRP = P_T + G_T - L_C$ ,  $ERP = EIRP - 2.15$ , where  
 $P_T$  = transmitter output power in dBm  
 $G_T$  = gain of the transmitting antenna in dBi  
 $L_C$  = signal attenuation in the connecting cable between the transmitter and antenna in dB



## 3.7 Occupied Bandwidth

### 3.7.1 Description of Occupied Bandwidth Measurement

The occupied bandwidth is the width of a frequency band such that, below the lower and above the upper frequency limits, the mean powers emitted are each equal to a specified percentage 0.5% of the total mean transmitted power.

The 26 dB emission bandwidth is defined as the frequency range between two points, one above and one below the carrier frequency, at which the spectral density of the emission is attenuated 26 dB below the maximum in-band spectral density of the modulated signal. Spectral density (power per unit bandwidth) is to be measured with a detector of resolution bandwidth equal to approximately 1.0% of the emission bandwidth.

### 3.7.2 Test Procedures

1. The testing follows ANSI C63.26 Section 5.4
2. The EUT was connected to spectrum analyzer and system simulator via a power divider.
3. The spectrum analyzer center frequency is set to the nominal EUT channel center frequency. The span range for the spectrum analyzer shall be between two and five times the anticipated OBW.
4. The nominal resolution bandwidth (RBW) shall be in the range of 1 to 5 % of the anticipated OBW, and the VBW shall be at least 3 times the RBW.
5. Set the detection mode to peak, and the trace mode to max hold.
6. Determine the reference value: Set the EUT to transmit a modulated signal. Allow the trace to stabilize. Set the spectrum analyzer marker to the highest level of the displayed trace.  
(this is the reference value)
7. Determine the “-26 dB down amplitude” as equal to (Reference Value – X).
8. Place two markers, one at the lowest and the other at the highest frequency of the envelope of the spectral display such that each marker is at or slightly below the “-X dB down amplitude” determined in step 6. If a marker is below this “-X dB down amplitude” value it shall be placed as close as possible to this value. The OBW is the positive frequency difference between the two markers.
9. Use the 99 % power bandwidth function of the spectrum analyzer and report the measured bandwidth.

## 3.8 Conducted Band Edge Measurement

### 3.8.1 Description of Conducted Band Edge Measurement

#### § 27.53 (n)(2)

For mobile operations in the 3450-3550 MHz band, the conducted power of any emission outside the licensee's authorized bandwidth shall not exceed  $-13$  dBm/MHz.

Compliance with this paragraph is based on the use of measurement instrumentation employing a resolution bandwidth of 1 megahertz or greater. However, in the 1 megahertz bands immediately outside and adjacent to the licensee's frequency block, a resolution bandwidth of at least one percent of the emission bandwidth of the fundamental emission of the transmitter may be employed, but limited to a maximum of 200 kHz. In the bands between 1 and 5 MHz removed from the licensee's frequency block, the minimum resolution bandwidth for the measurement shall be 500 kHz.

### 3.8.2 Test Procedures

1. The testing follows ANSI C63.26 section 5.7
2. The EUT was connected to spectrum analyzer and system simulator via a power divider.
3. The band edges of low and high channels for the highest RF powers were measured.
4. Set RBW  $\geq$  1% EBW but limited to a maximum of 200 kHz in the 1MHz band immediately outside and adjacent to the band edge.
5. Beyond the 1 MHz and 5 MHz removed from the band edge, set RBW  $\geq$  500KHz.
6. Beyond the 5 MHz removed from the band edge, set RBW = 1MHz.
7. Set spectrum analyzer with RMS detector.
8. The RF fundamental frequency should be excluded against the limit line in the operating frequency band.
9. Checked that all the results comply with the emission limit line.

## 3.9 Conducted Spurious Emission Measurement

### 3.9.1 Description of Conducted Spurious Emission Measurement

The power of any emission outside of the authorized operating frequency ranges shall not exceed -13 dBm/MHz.

It is measured by means of a calibrated spectrum analyzer and scanned from 9 kHz up to a frequency including its 10<sup>th</sup> harmonic.

### 3.9.2 Test Procedures

1. The testing follows ANSI C63.26 section 5.7
2. The EUT was connected to spectrum analyzer and system simulator via a power divider.
3. The RF output of EUT was connected to the spectrum analyzer by RF cable and attenuator. The path loss was compensated to the results for each measurement.
4. The middle channel for the highest RF power within the transmitting frequency was measured.
5. The conducted spurious emission for the whole frequency range was taken.
6. Make the measurement with the spectrum analyzer's RBW = 1MHz, VBW = 3MHz.
7. Set spectrum analyzer with RMS detector.
8. Taking the record of maximum spurious emission.
9. The RF fundamental frequency should be excluded against the limit line in the operating frequency band.
10. Checked that all the results comply with the emission limit line.

## 3.10 Frequency Stability Measurement

### 3.10.1 Description of Frequency Stability Measurement

The frequency stability shall be measured by variation of ambient temperature and variation of primary supply voltage to ensure that the fundamental emission stays within the authorized frequency block.

### 3.10.2 Test Procedures for Temperature Variation

1. The testing follows ANSI C63.26 section 5.6.4
2. The EUT was set up in the thermal chamber and connected with the system simulator.
3. With power OFF, the temperature was decreased to  $-30^{\circ}\text{C}$  and the EUT was stabilized before testing. Power was applied and the maximum change in frequency was recorded within one minute.
4. With power OFF, the temperature was raised in  $10^{\circ}\text{C}$  step up to  $50^{\circ}\text{C}$ . The EUT was stabilized at each step for at least half an hour. Power was applied and the maximum frequency change was recorded within one minute.

### 3.10.3 Test Procedures for Voltage Variation

1. The testing follows ANSI C63.26 section 5.6.5.
2. The EUT was placed in a temperature chamber at  $20\pm 5^{\circ}\text{C}$  and connected with the system simulator.
3. The power supply voltage to the EUT was varied from 85% to 115% of the nominal value for other than hand carried battery equipment.
4. For hand carried, battery powered equipment, reduce the primary ac or dc supply voltage to the battery operating end point, which shall be specified by the manufacturer.
5. The variation in frequency was measured for the worst case.

## 4 Radiated Test Items

### 4.1 Measuring Instruments

See list of measuring instruments of this test report.

### 4.2 Test Setup

#### 4.2.1 For radiated test below 30MHz

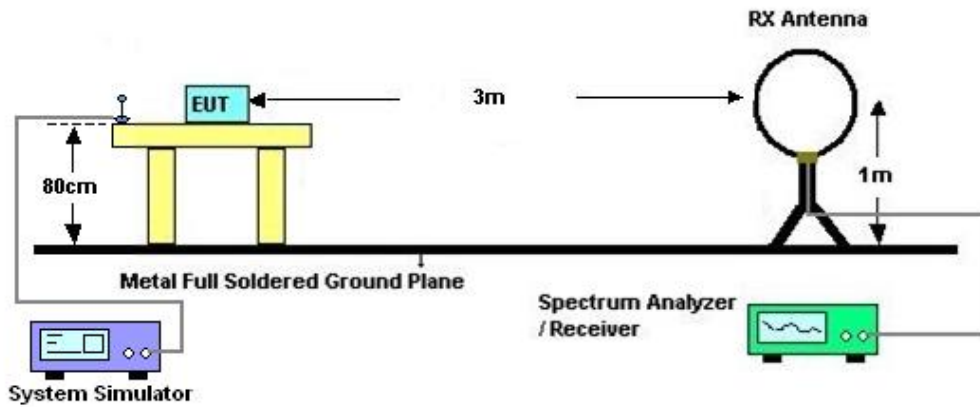

#### 4.2.2 For radiated test from 30MHz to 1GHz

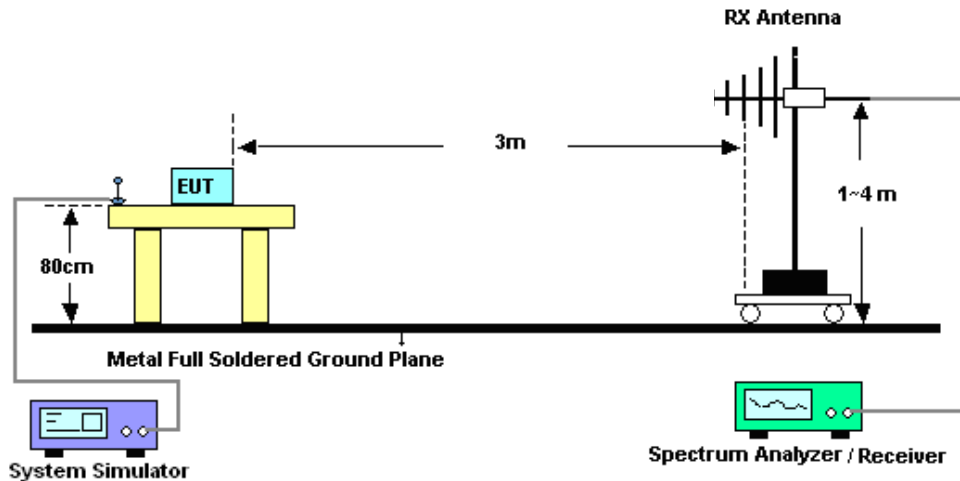

### 4.2.3 For radiated test above 1GHz

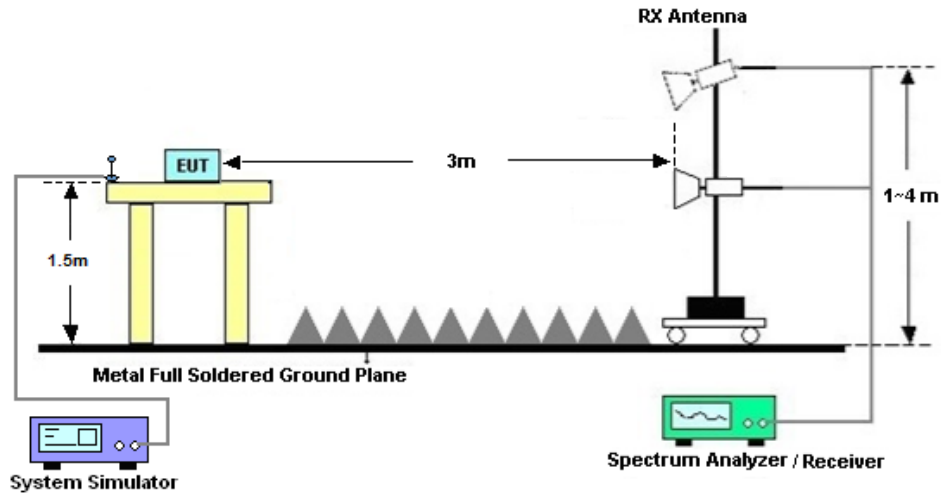

## 4.3 Test Result of Radiated Test

The low frequency, which started from 9 kHz to 30MHz, was pre-scanned and the result which was 20dB lower than the limit line was not reported.

Please refer to Appendix B.

## 4.4 Radiated Spurious Emission Measurement

### 4.4.1 Description of Radiated Spurious Emission

The radiated spurious emission was measured by substitution method according to ANSI/TIA-603-E. The power of any emission outside of the authorized operating frequency ranges shall not exceed -13 dBm/MHz.

The spectrum is scanned from 30 MHz up to a frequency including its 10th harmonic.

### 4.4.2 Test Procedures

1. The testing follows ANSI C63.26 Section 5.5
2. The EUT was placed on a turntable with 0.8 meter height for frequency below 1GHz and 1.5 meter height for frequency above 1GHz respectively above ground.
3. The EUT was set 3 meters from the receiving antenna mounted on the antenna tower.
4. The table was rotated 360 degrees to determine the position of the highest spurious emission.
5. The height of the receiving antenna is varied between 1m to 4m to search the maximum spurious emission for both horizontal and vertical polarizations.
6. During the measurement, the system simulator parameters were set to force the EUT transmitting at maximum output power.
7. Make the measurement with the spectrum analyzer's RBW = 1MHz, VBW = 3MHz, taking the record of maximum spurious emission.
8. A horn antenna was substituted in place of the EUT and was driven by a signal generator.
9. Tune the output power of signal generator to the same emission level with EUT maximum spurious emission.  
$$\text{EIRP (dBm)} = \text{S.G. Power} - \text{Tx Cable Loss} + \text{Tx Antenna Gain}$$
$$\text{ERP (dBm)} = \text{EIRP} - 2.15$$
10. The RF fundamental frequency should be excluded against the limit line in the operating frequency band.

## 5 List of Measuring Equipment

Instrument	Manufacturer	Model No.	Serial No.	Characteristics	Calibration Date	Test Date	Due Date	Remark
Spectrum Analyzer	R&S	FSV40	101078	10Hz~40GHz	Apr. 07, 2022	May 23, 2022~ Aug. 18, 2022	Apr. 06, 2023	Conducted (TH01-SZ)
Power Divider	TOJOIN	PS-2SM-04 265	60.06.020.007 7	0.4GHz~26.5GHz	Dec. 25, 2021	May 23, 2022~ Aug. 18, 2022	Dec. 24, 2022	Conducted (TH01-SZ)
Thermal Chamber	Ten Billion Hongzhangroup	LP-150U	H2014081803	-40~+150°C	Jul. 14, 2021	May 23, 2022~ Aug. 18, 2022	Jul. 13, 2022	Conducted (TH01-SZ)
Thermal Chamber	Ten Billion Hongzhangroup	LP-150U	H2014081803	-40~+150°C	Jul. 13, 2022		Jul. 12, 2023	Conducted (TH01-SZ)
EXA Spectrum Analyzer	Keysight	N9010B	MY57541079	10Hz-44G,MAX 30dB	Oct. 14, 2022	May 31, 2022	Oct. 13, 2023	Radiation (03CH04-KS)
Loop Antenna	R&S	HFH2-Z2	100321	9kHz~30MHz	Oct. 30, 2021	May 31, 2022	Oct. 29, 2022	Radiation (03CH04-KS)
Bilog Antenna	TeseQ	CBL6111D	49922	30MHz-1GHz	May 24, 2022	May 31, 2022	May 23, 2023	Radiation (03CH04-KS)
Horn Antenna	Schwarzbeck	BBHA9120D	1284	1GHz~18GHz	Jan. 05, 2022	May 31, 2022	Jan. 04, 2023	Radiation (03CH04-KS)
SHF-EHF Horn	Com-power	AH-840	101070	18GHz~40GHz	Jan. 05, 2022	May 31, 2022	Jan. 04, 2023	Radiation (03CH04-KS)
Amplifier	SONOMA	310N	187289	9KHz-1GHz	Jan. 05, 2022	May 31, 2022	Jan. 04, 2023	Radiation (03CH04-KS)
Amplifier	MITEQ	EM18G40G GA	060728	18~40GHz	Jan. 05, 2022	May 31, 2022	Jan. 04, 2023	Radiation (03CH04-KS)
high gain Amplifier	MITEQ	AMF-7D-00 101800-30-1 0P	2025788	1Ghz-18Ghz	Jul. 30, 2021	May 31, 2022	Jul. 29, 2022	Radiation (03CH04-KS)
Amplifier	Keysight	83017A	MY57280106	500MHz~26.5GHz	Oct. 13, 2021	May 31, 2022	Oct. 12, 2022	Radiation (03CH04-KS)
AC Power Source	Chroma	61601	F104090004	N/A	NCR	May 31, 2022	NCR	Radiation (03CH04-KS)
Turn Table	ChamPro	EM 1000-T	060762-T	0~360 degree	NCR	May 31, 2022	NCR	Radiation (03CH04-KS)
Antenna Mast	ChamPro	EM 1000-A	060762-A	1 m~4 m	NCR	May 31, 2022	NCR	Radiation (03CH04-KS)
EMI Test Receiver&SA	KEYSIGHT	N9038A	MY54450083	20Hz~8.4GHz	Apr. 06, 2022	Aug. 22, 2022	Apr. 05, 2023	Radiation (03CH03-SZ)
Loop Antenna	R&S	HFH2-Z2	100354	9kHz~30MHz	Jun. 28, 2022	Aug. 22, 2022	Jun. 27, 2024	Radiation (03CH03-SZ)
EXA Spectrum Anaiyzer	KEYSIGHT	N9010A	MY55150246	10Hz~44GHz;	Apr. 06, 2022	Aug. 22, 2022	Apr. 05, 2023	Radiation (03CH03-SZ)
Bilog Antenna	TeseQ	CBL6112D	35408	30MHz-2GHz	Aug. 09, 2021	Aug. 22, 2022	Aug. 08, 2023	Radiation (03CH03-SZ)
Double Ridge Horn Antenna	SCHWARZBECK	BBHA9120D	9120D-1355	1GHz~18GHz	Apr. 08, 2022	Aug. 22, 2022	Apr. 07, 2023	Radiation (03CH03-SZ)
Amplifier	Burgeon	BPA-530	102211	0.01Hz ~3000MHz	Oct. 22, 2021	Aug. 22, 2022	Oct. 21, 2022	Radiation (03CH03-SZ)
HF Amplifier	MITEQ	TTA1840-35 -HG	1871923	18GHz~40GHz	Oct. 22, 2021	Aug. 22, 2022	Oct. 21, 2022	Radiation (03CH03-SZ)





SHF-EHF Horn	com-power	AH-840	101071	18Ghz-40GHz	Apr. 10, 2022	Aug. 22, 2022	Apr. 09, 2023	Radiation (03CH03-SZ)
Amplifier	Agilent Technologies	83017A	MY39501302	500MHz~26.5GHz	Dec. 27,2021	Aug. 22, 2022	Dec. 26,2022	Radiation (03CH03-SZ)
AC Power Source	Chroma	61601	616010001985	N/A	NCR	Aug. 22, 2022	NCR	Radiation (03CH03-SZ)
Turn Table	EM	EM1000	N/A	0~360 degree	NCR	Aug. 22, 2022	NCR	Radiation (03CH03-SZ)
Antenna Mast	EM	EM1000	N/A	1 m~4 m	NCR	Aug. 22, 2022	NCR	Radiation (03CH03-SZ)

NCR: No Calibration Required

## 6 Uncertainty of Evaluation

The measurement uncertainties shown below were calculated in accordance with the requirements of ANSI 63.26-2015. All the measurement uncertainty value were shown with a coverage K=2 to indicate 95% level of confidence. The measurement data show herein meets or exceeds the CISPR measurement uncertainty values specified in CISPR 16-4-2 and can be compared directly to specified limit to determine compliance.

### 03CH04-KS

#### Uncertainty of Radiated Emission Measurement (30 MHz ~ 1000 MHz)

Measuring Uncertainty for a Level of Confidence of 95% (U = 2Uc(y))	3.3dB
---	-------

#### Uncertainty of Radiated Emission Measurement (1 GHz ~ 18 GHz)

Measuring Uncertainty for a Level of Confidence of 95% (U = 2Uc(y))	2.8dB
---	-------

#### Uncertainty of Radiated Emission Measurement (18 GHz ~ 40 GHz)

Measuring Uncertainty for a Level of Confidence of 95% (U = 2Uc(y))	2.8dB
---	-------

### 03CH03-SZ

#### Uncertainty of Radiated Emission Measurement (30 MHz ~ 1000 MHz)

Measuring Uncertainty for a Level of Confidence of 95% (U = 2Uc(y))	3.0dB
---	-------

#### Uncertainty of Radiated Emission Measurement (1 GHz ~ 18 GHz)

Measuring Uncertainty for a Level of Confidence of 95% (U = 2Uc(y))	3.6dB
---	-------

#### Uncertainty of Radiated Emission Measurement (18 GHz ~ 40 GHz)

Measuring Uncertainty for a Level of Confidence of 95% (U = 2Uc(y))	3.8dB
---	-------

----- THE END -----



## Appendix A. Test Results of Conducted Test

Test Engineer :	Jung Guo	Temperature :	22~23°C
		Relative Humidity :	40~42%

## FR1 N77 (ANT5)

### Transmitter Conducted Output Power And EIRP, (G<sub>T</sub> - L<sub>C</sub>)= -5.39dB

NR Band	SCS (kHz)	Bandwidth (MHz)	Arfcn	Freq (MHz)	Modulation	RB	Conducted Power(dBm)	EIRP (dBm)	EIRP (W)
77	30	10	630334	3455.01	DFT-s-OFDM QPSK	1@1	22.53	17.14	0.0518
77	30	10	630334	3455.01	DFT-s-OFDM 16 QAM	1@1	21.61	16.22	0.0419
77	30	10	633334	3500.01	DFT-s-OFDM QPSK	1@1	23.34	17.95	0.0624
77	30	10	633334	3500.01	DFT-s-OFDM 16 QAM	1@1	22.35	16.96	0.0497
77	30	10	636332	3544.98	DFT-s-OFDM QPSK	1@1	22.96	17.57	0.0571
77	30	10	636332	3544.98	DFT-s-OFDM 16 QAM	1@1	22.01	16.62	0.0459
77	30	15	630500	3457.5	DFT-s-OFDM QPSK	1@1	22.75	17.36	0.0545
77	30	15	630500	3457.5	DFT-s-OFDM 16 QAM	1@1	21.91	16.52	0.0449
77	30	15	633334	3500.01	DFT-s-OFDM QPSK	1@1	23.53	18.14	0.0652
77	30	15	633334	3500.01	DFT-s-OFDM 16 QAM	1@1	22.59	17.2	0.0525
77	30	15	636166	3542.49	DFT-s-OFDM QPSK	1@1	23.14	17.75	0.0596
77	30	15	636166	3542.49	DFT-s-OFDM 16 QAM	1@1	22.26	16.87	0.0486
77	30	20	630668	3460.02	DFT-s-OFDM QPSK	1@1	22.79	17.4	0.0550
77	30	20	630668	3460.02	DFT-s-OFDM 16 QAM	1@1	21.78	16.39	0.0436
77	30	20	633334	3500.01	DFT-s-OFDM QPSK	1@1	23.44	18.05	0.0638
77	30	20	633334	3500.01	DFT-s-OFDM 16 QAM	1@1	21.82	16.43	0.0440
77	30	20	636000	3540	DFT-s-OFDM QPSK	1@1	23.27	17.88	0.0614
77	30	20	636000	3540	DFT-s-OFDM 16 QAM	1@1	22.38	16.99	0.0500
77	30	30	631000	3465	DFT-s-OFDM QPSK	1@1	22.88	17.49	0.0561
77	30	30	631000	3465	DFT-s-OFDM 16 QAM	1@1	21.98	16.59	0.0456
77	30	30	633334	3500.01	DFT-s-OFDM QPSK	1@1	23.45	18.06	0.0640
77	30	30	633334	3500.01	DFT-s-OFDM 16 QAM	1@1	22.58	17.19	0.0524
77	30	30	635666	3534.99	DFT-s-OFDM QPSK	1@1	23.74	18.35	0.0684
77	30	30	635666	3534.99	DFT-s-OFDM 16 QAM	1@1	22.68	17.29	0.0536
77	30	40	631334	3470.01	DFT-s-OFDM QPSK	1@1	22.88	17.49	0.0561
77	30	40	631334	3470.01	DFT-s-OFDM 16 QAM	1@1	21.93	16.54	0.0451
77	30	40	633334	3500.01	DFT-s-OFDM QPSK	1@1	23.45	18.06	0.0640
77	30	40	633334	3500.01	DFT-s-OFDM 16 QAM	1@1	22.47	17.08	0.0511
77	30	40	635332	3529.98	DFT-s-OFDM QPSK	1@1	23.71	18.32	0.0679

77	30	40	635332	3529.98	DFT-s-OFDM 16 QAM	1@1	22.91	17.52	0.0565
77	30	50	631668	3475.02	DFT-s-OFDM QPSK	1@1	22.65	17.26	0.0532
77	30	50	631668	3475.02	DFT-s-OFDM 16 QAM	1@1	21.72	16.33	0.0430
77	30	50	633334	3500.01	DFT-s-OFDM QPSK	1@1	23.13	17.74	0.0594
77	30	50	633334	3500.01	DFT-s-OFDM 16 QAM	1@1	22.27	16.88	0.0488
77	30	50	635000	3525	DFT-s-OFDM QPSK	1@1	23.59	18.2	0.0661
77	30	50	635000	3525	DFT-s-OFDM 16 QAM	1@1	22.21	16.82	0.0481
77	30	60	632000	3480	DFT-s-OFDM QPSK	1@1	22.64	17.25	0.0531
77	30	60	632000	3480	DFT-s-OFDM 16 QAM	1@1	21.71	16.32	0.0429
77	30	60	633334	3500.01	DFT-s-OFDM QPSK	1@1	22.99	17.6	0.0575
77	30	60	633334	3500.01	DFT-s-OFDM 16 QAM	1@1	21.83	16.44	0.0441
77	30	60	634666	3519.99	DFT-s-OFDM QPSK	1@1	23.41	18.02	0.0634
77	30	60	634666	3519.99	DFT-s-OFDM 16 QAM	1@1	22.58	17.19	0.0524
77	30	70	632334	3485.01	DFT-s-OFDM QPSK	1@1	23.29	17.9	0.0617
77	30	70	632334	3485.01	DFT-s-OFDM 16 QAM	1@1	21.78	16.39	0.0436
77	30	70	633334	3500.01	DFT-s-OFDM QPSK	1@1	22.73	17.34	0.0542
77	30	70	633334	3500.01	DFT-s-OFDM 16 QAM	1@1	21.89	16.5	0.0447
77	30	70	634332	3514.98	DFT-s-OFDM QPSK	1@1	23.12	17.73	0.0593
77	30	70	634332	3514.98	DFT-s-OFDM 16 QAM	1@1	22.22	16.83	0.0482
77	30	80	632668	3490.02	DFT-s-OFDM QPSK	1@1	22.63	17.24	0.0530
77	30	80	632668	3490.02	DFT-s-OFDM 16 QAM	1@1	21.75	16.36	0.0433
77	30	80	633334	3500.01	DFT-s-OFDM QPSK	1@1	22.66	17.27	0.0533
77	30	80	633334	3500.01	DFT-s-OFDM 16 QAM	1@1	21.83	16.44	0.0441
77	30	80	634000	3510	DFT-s-OFDM QPSK	1@1	22.91	17.52	0.0565
77	30	80	634000	3510	DFT-s-OFDM 16 QAM	1@1	-32.92	-38.31	0.0000
77	30	90	633000	3495	DFT-s-OFDM QPSK	1@1	22.54	17.15	0.0519
77	30	90	633000	3495	DFT-s-OFDM 16 QAM	1@1	21.73	16.34	0.0431
77	30	90	633334	3500.01	DFT-s-OFDM QPSK	1@1	22.61	17.22	0.0527
77	30	90	633334	3500.01	DFT-s-OFDM 16 QAM	1@1	21.78	16.39	0.0436
77	30	90	633666	3504.99	DFT-s-OFDM QPSK	1@1	22.77	17.38	0.0547
77	30	90	633666	3504.99	DFT-s-OFDM 16 QAM	1@1	21.88	16.49	0.0446
77	30	100	633334	3500.01	DFT-s-OFDM PI/2 BPSK	135@67	23.26	17.87	0.0612
77	30	100	633334	3500.01	DFT-s-OFDM PI/2 BPSK	1@1	22.61	17.22	0.0527
77	30	100	633334	3500.01	DFT-s-OFDM PI/2 BPSK	1@271	22.56	17.17	0.0521

77	30	100	633334	3500.01	DFT-s-OFDM QPSK	135@67	23.82	18.43	0.0697
77	30	100	633334	3500.01	DFT-s-OFDM QPSK	1@1	22.47	17.08	0.0511
77	30	100	633334	3500.01	DFT-s-OFDM QPSK	1@271	22.55	17.16	0.0520
77	30	100	633334	3500.01	DFT-s-OFDM 16 QAM	135@67	22.25	16.86	0.0485
77	30	100	633334	3500.01	DFT-s-OFDM 16 QAM	1@1	21.57	16.18	0.0415
77	30	100	633334	3500.01	DFT-s-OFDM 16 QAM	1@271	21.58	16.19	0.0416
77	30	100	633334	3500.01	DFT-s-OFDM 64 QAM	135@67	20.75	15.36	0.0344
77	30	100	633334	3500.01	DFT-s-OFDM 64 QAM	1@1	20.05	14.66	0.0292
77	30	100	633334	3500.01	DFT-s-OFDM 64 QAM	1@271	20.05	14.66	0.0292
77	30	100	633334	3500.01	DFT-s-OFDM 256 QAM	135@67	18.76	13.37	0.0217
77	30	100	633334	3500.01	DFT-s-OFDM 256 QAM	1@1	17.98	12.59	0.0182
77	30	100	633334	3500.01	DFT-s-OFDM 256 QAM	1@271	17.95	12.56	0.0180
77	30	100	633334	3500.01	CP-OFDM QPSK	137@68	21.71	16.32	0.0429
77	30	100	633334	3500.01	CP-OFDM QPSK	1@1	20.99	15.6	0.0363
77	30	100	633334	3500.01	CP-OFDM QPSK	1@271	20.95	15.56	0.0360

## Frequency Stability

NR Band	SCS (kHz)	Bandwidth (MHz)	Arfcn	Freq (MHz)	Modulation	RB	Deviation (ppm)	Verdict	Environment
77	30	20	633334	3500.01	DFT-s-OFDM QPSK	50@0	0.00756	PASS	NV
77	30	20	633334	3500.01	DFT-s-OFDM QPSK	50@0	0.00471	PASS	LV
77	30	20	633334	3500.01	DFT-s-OFDM QPSK	50@0	0.00523	PASS	HV
77	30	20	633334	3500.01	DFT-s-OFDM QPSK	50@0	0.00645	PASS	-30°C
77	30	20	633334	3500.01	DFT-s-OFDM QPSK	50@0	0.00451	PASS	-20°C
77	30	20	633334	3500.01	DFT-s-OFDM QPSK	50@0	0.00543	PASS	-10°C
77	30	20	633334	3500.01	DFT-s-OFDM QPSK	50@0	0.00153	PASS	0°C
77	30	20	633334	3500.01	DFT-s-OFDM QPSK	50@0	0.00602	PASS	10°C
77	30	20	633334	3500.01	DFT-s-OFDM QPSK	50@0	0.00654	PASS	20°C
77	30	20	633334	3500.01	DFT-s-OFDM QPSK	50@0	0.00581	PASS	30°C
77	30	20	633334	3500.01	DFT-s-OFDM QPSK	50@0	0.00232	PASS	40°C
77	30	20	633334	3500.01	DFT-s-OFDM QPSK	50@0	0.00464	PASS	50°C

## Peak to Average Ratio

NR Band	SCS (kHz)	Bandwidth (MHz)	Arfcn	Freq (MHz)	Modulation	RB	Result (dB)	Limit (dB)	Verdict
77	30	20	630668	3460.02	DFT-s-OFDM PI/2 BPSK	50@0	7.23	13	PASS
77	30	20	630668	3460.02	DFT-s-OFDM PI/2 BPSK	1@0	7.75	13	PASS
77	30	20	630668	3460.02	DFT-s-OFDM QPSK	50@0	8.94	13	PASS
77	30	20	630668	3460.02	DFT-s-OFDM QPSK	1@0	9.11	13	PASS
77	30	20	633334	3500.01	DFT-s-OFDM PI/2 BPSK	50@0	7.56	13	PASS
77	30	20	633334	3500.01	DFT-s-OFDM PI/2 BPSK	1@0	7.79	13	PASS
77	30	20	633334	3500.01	DFT-s-OFDM QPSK	50@0	9.43	13	PASS
77	30	20	633334	3500.01	DFT-s-OFDM QPSK	1@0	8.3	13	PASS
77	30	20	636000	3540.0	DFT-s-OFDM PI/2 BPSK	50@0	7.52	13	PASS
77	30	20	636000	3540.0	DFT-s-OFDM PI/2 BPSK	1@0	8.07	13	PASS
77	30	20	636000	3540.0	DFT-s-OFDM QPSK	50@0	8.55	13	PASS
77	30	20	636000	3540.0	DFT-s-OFDM QPSK	1@0	8.9	13	PASS



N77(20M)\_DFT-s-OFDM\_PI\_2-BPSK\_Outer\_Full\_Low\_CH



N77(20M)\_DFT-s-OFDM\_PI\_2-BPSK\_Edge\_1RB\_Left\_Low\_CH



N77(20M)\_DFT-s-OFDM\_QPSK\_Outer\_Full\_Low\_CH

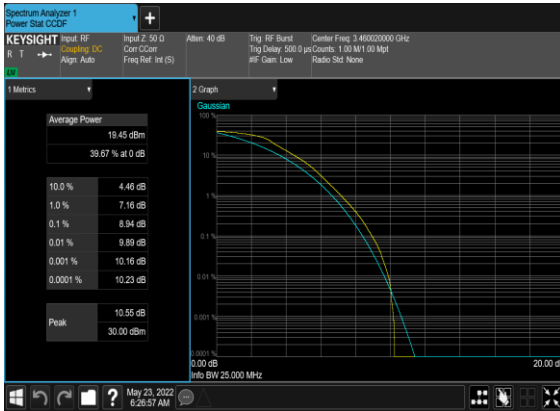

N77(20M)\_DFT-s-OFDM\_QPSK\_Edge\_1RB\_Left\_Low\_CH

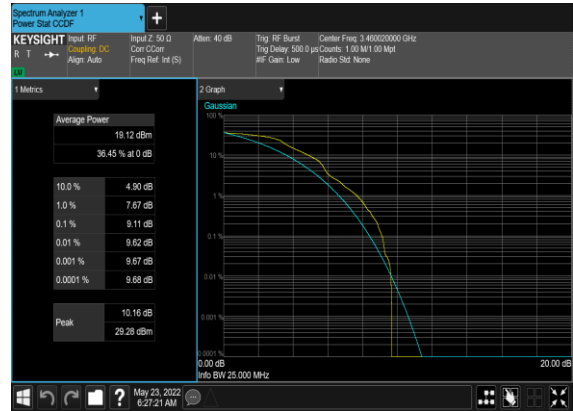

N77(20M)\_DFT-s-OFDM\_PI\_2-BPSK\_Outer\_Full\_Mid\_CH



N77(20M)\_DFT-s-OFDM\_PI\_2-BPSK\_Edge\_1RB\_Left\_Mid\_CH

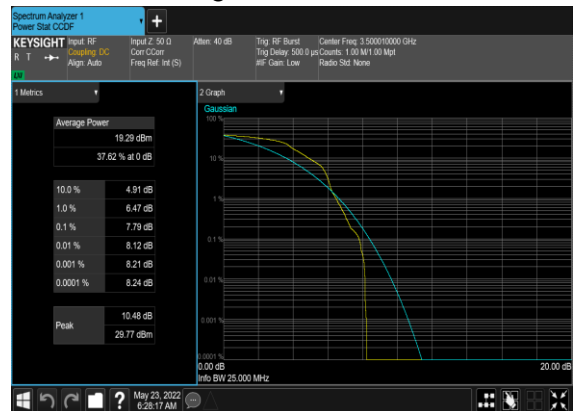

N77(20M)\_DFT-s-OFDM\_QPSK\_Outer\_Full\_Mid\_CH



N77(20M)\_DFT-s-OFDM\_QPSK\_Edge\_1RB\_Left\_Mid\_CH

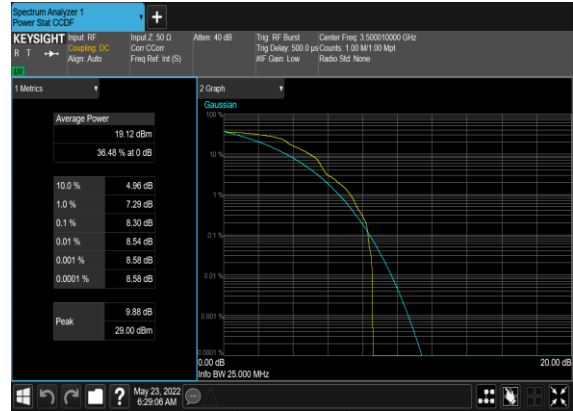

N77(20M)\_DFT-s-OFDM\_PI\_2-BPSK\_Outer\_Full\_High\_CH

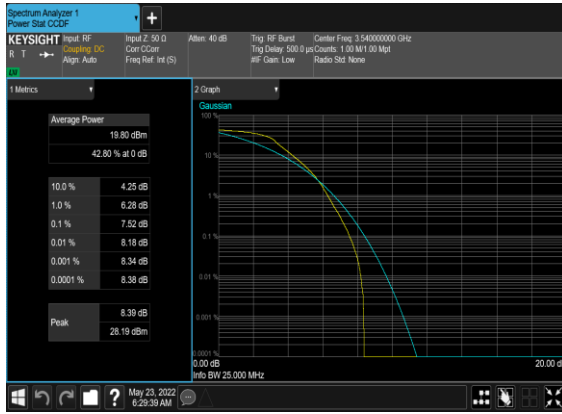

N77(20M)\_DFT-s-OFDM\_PI\_2-BPSK\_Edge\_1RB\_Left\_High\_CH

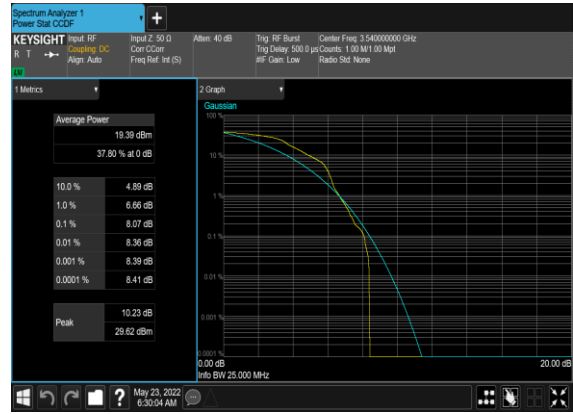

N77(20M)\_DFT-s-OFDM\_QPSK\_Outer\_Full\_High\_CH

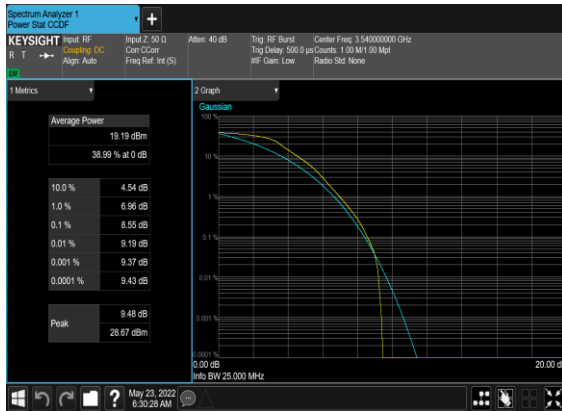

N77(20M)\_DFT-s-OFDM\_QPSK\_Edge\_1RB\_Left\_High\_CH



## Occupied Bandwidth

NR Band	SCS (kHz)	Bandwidth (MHz)	Arfcn	Freq (MHz)	Modulation	RB	OBW (MHz)	26dB OBW (MHz)
77	30	10	633334	3500.01	DFT-s-OFDM PI/2 BPSK	24@0	8.6178	9.986
77	30	10	633334	3500.01	DFT-s-OFDM QPSK	24@0	8.5926	10.43
77	30	10	633334	3500.01	CP-OFDM QPSK	24@0	8.5976	10.06
77	30	10	633334	3500.01	CP-OFDM 16 QAM	24@0	8.5932	9.607
77	30	10	633334	3500.01	CP-OFDM 64 QAM	24@0	8.5988	9.941
77	30	10	633334	3500.01	CP-OFDM 256 QAM	24@0	8.5665	9.707
77	30	15	633334	3500.01	DFT-s-OFDM PI/2 BPSK	36@0	12.836	14.91
77	30	15	633334	3500.01	DFT-s-OFDM QPSK	36@0	12.856	13.97
77	30	15	633334	3500.01	CP-OFDM QPSK	38@0	13.6	15.75
77	30	15	633334	3500.01	CP-OFDM 16 QAM	38@0	13.583	14.88
77	30	15	633334	3500.01	CP-OFDM 64 QAM	38@0	13.584	15.89
77	30	15	633334	3500.01	CP-OFDM 256 QAM	38@0	13.567	15.63
77	30	20	633334	3500.01	DFT-s-OFDM PI/2 BPSK	50@0	17.796	19.25
77	30	20	633334	3500.01	DFT-s-OFDM QPSK	50@0	17.788	20.13
77	30	20	633334	3500.01	CP-OFDM QPSK	51@0	18.2	21.42
77	30	20	633334	3500.01	CP-OFDM 16 QAM	51@0	18.225	19.84
77	30	20	633334	3500.01	CP-OFDM 64 QAM	51@0	18.246	19.76
77	30	20	633334	3500.01	CP-OFDM 256 QAM	51@0	18.2	20.13
77	30	30	633334	3500.01	DFT-s-OFDM PI/2 BPSK	75@0	26.728	28.39
77	30	30	633334	3500.01	DFT-s-OFDM QPSK	75@0	26.742	28.98
77	30	30	633334	3500.01	CP-OFDM QPSK	78@0	27.846	30.14
77	30	30	633334	3500.01	CP-OFDM 16 QAM	78@0	27.927	30.17
77	30	30	633334	3500.01	CP-OFDM 64 QAM	78@0	27.859	29.83
77	30	30	633334	3500.01	CP-OFDM 256 QAM	78@0	27.82	29.35
77	30	40	633334	3500.01	DFT-s-OFDM PI/2 BPSK	100@0	35.742	37.49

77	30	40	633334	3500.01	DFT-s-OFDM QPSK	100@0	35.744	38.34
77	30	40	633334	3500.01	CP-OFDM QPSK	106@0	37.818	40.08
77	30	40	633334	3500.01	CP-OFDM 16 QAM	106@0	37.856	40.02
77	30	40	633334	3500.01	CP-OFDM 64 QAM	106@0	37.817	39.48
77	30	40	633334	3500.01	CP-OFDM 256 QAM	106@0	37.849	39.66
77	30	50	633334	3500.01	DFT-s-OFDM PI/2 BPSK	128@0	45.781	47.76
77	30	50	633334	3500.01	DFT-s-OFDM QPSK	128@0	45.74	48.1
77	30	50	633334	3500.01	CP-OFDM QPSK	133@0	47.535	54.9
77	30	50	633334	3500.01	CP-OFDM 16 QAM	133@0	47.502	49.39
77	30	50	633334	3500.01	CP-OFDM 64 QAM	133@0	47.533	49.35
77	30	50	633334	3500.01	CP-OFDM 256 QAM	133@0	47.567	49.27
77	30	60	633334	3500.01	DFT-s-OFDM PI/2 BPSK	162@0	57.878	60.13
77	30	60	633334	3500.01	DFT-s-OFDM QPSK	162@0	57.91	60.23
77	30	60	633334	3500.01	CP-OFDM QPSK	162@0	57.801	61.5
77	30	60	633334	3500.01	CP-OFDM 16 QAM	162@0	57.832	60.15
77	30	60	633334	3500.01	CP-OFDM 64 QAM	162@0	57.853	60.21
77	30	60	633334	3500.01	CP-OFDM 256 QAM	162@0	57.849	60.24
77	30	70	633334	3500.01	DFT-s-OFDM PI/2 BPSK	180@0	64.443	66.54
77	30	70	633334	3500.01	DFT-s-OFDM QPSK	180@0	64.281	66.6
77	30	70	633334	3500.01	CP-OFDM QPSK	189@0	67.456	69.84
77	30	70	633334	3500.01	CP-OFDM 16 QAM	189@0	67.396	70.58
77	30	70	633334	3500.01	CP-OFDM 64 QAM	189@0	67.371	70.77
77	30	70	633334	3500.01	CP-OFDM 256 QAM	189@0	67.514	69.8
77	30	80	633334	3500.01	DFT-s-OFDM PI/2 BPSK	216@0	77.171	80.02
77	30	80	633334	3500.01	DFT-s-OFDM QPSK	216@0	77.126	79.75
77	30	80	633334	3500.01	CP-OFDM QPSK	217@0	77.552	81.2
77	30	80	633334	3500.01	CP-OFDM 16 QAM	217@0	77.549	80.54

77	30	80	633334	3500.01	CP-OFDM 64 QAM	217@0	77.583	80.17
77	30	80	633334	3500.01	CP-OFDM 256 QAM	217@0	77.363	80.53
77	30	90	633334	3500.01	DFT-s-OFDM PI/2 BPSK	240@0	85.74	88.57
77	30	90	633334	3500.01	DFT-s-OFDM QPSK	240@0	85.799	91.55
77	30	90	633334	3500.01	CP-OFDM QPSK	245@0	87.634	92.57
77	30	90	633334	3500.01	CP-OFDM 16 QAM	245@0	87.248	91.13
77	30	90	633334	3500.01	CP-OFDM 64 QAM	245@0	87.409	90.39
77	30	90	633334	3500.01	CP-OFDM 256 QAM	245@0	87.691	90.9
77	30	100	633334	3500.01	DFT-s-OFDM PI/2 BPSK	270@0	96.577	99.5
77	30	100	633334	3500.01	DFT-s-OFDM QPSK	270@0	96.42	99.76
77	30	100	633334	3500.01	CP-OFDM QPSK	273@0	97.597	101.9
77	30	100	633334	3500.01	CP-OFDM 16 QAM	273@0	97.481	100.6
77	30	100	633334	3500.01	CP-OFDM 64 QAM	273@0	97.395	101.0
77	30	100	633334	3500.01	CP-OFDM 256 QAM	273@0	97.546	100.6

### N77(10M)\_DFT-s-OFDM\_PI\_2- BPSK\_Outer\_Full\_Mid\_CH

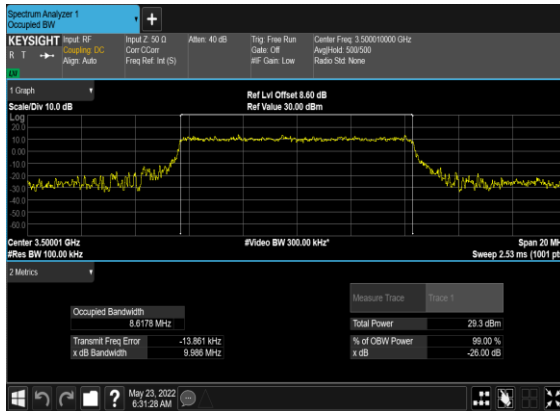

### N77(10M)\_DFT-s- OFDM\_QPSK\_Outer\_Full\_Mid\_CH

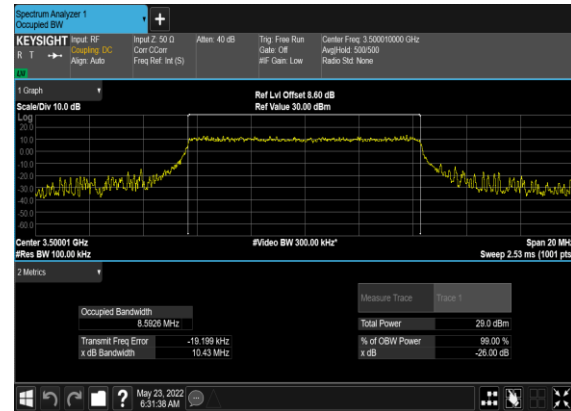

### N77(10M)\_CP- OFDM\_QPSK\_Outer\_Full\_Mid\_CH

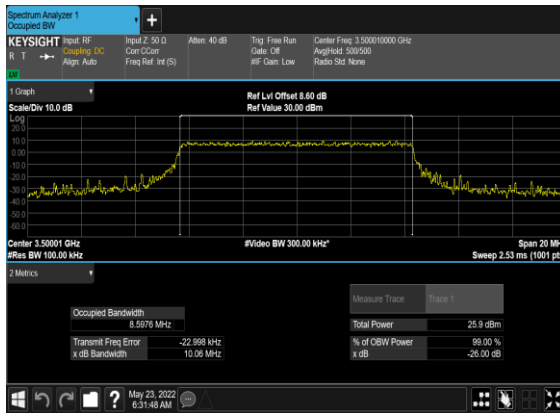

### N77(10M)\_CP-OFDM\_16 QAM\_Outer\_Full\_Mid\_CH

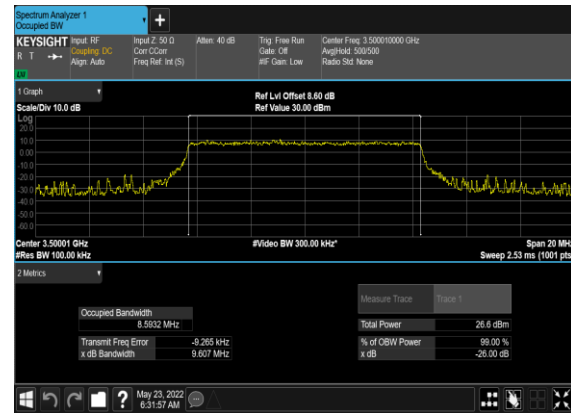

### N77(10M)\_CP-OFDM\_64 QAM\_Outer\_Full\_Mid\_CH

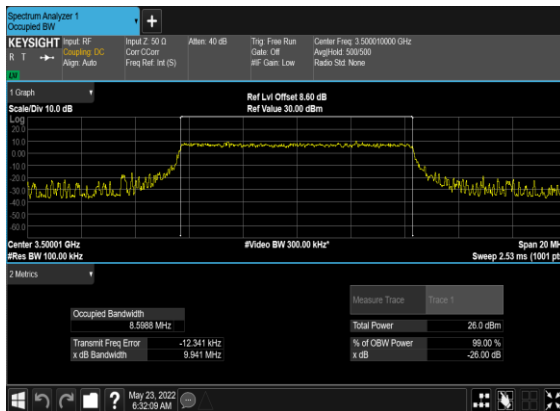

### N77(10M)\_CP-OFDM\_256 QAM\_Outer\_Full\_Mid\_CH

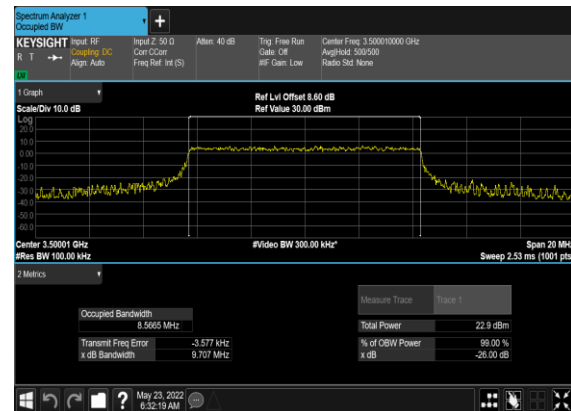

### N77(15M)\_DFT-s-OFDM\_PI\_2-BPSK\_Outer\_Full\_Mid\_CH

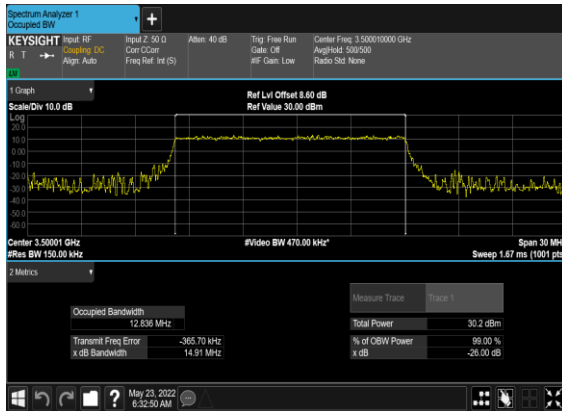

### N77(15M)\_DFT-s-OFDM\_QPSK\_Outer\_Full\_Mid\_CH

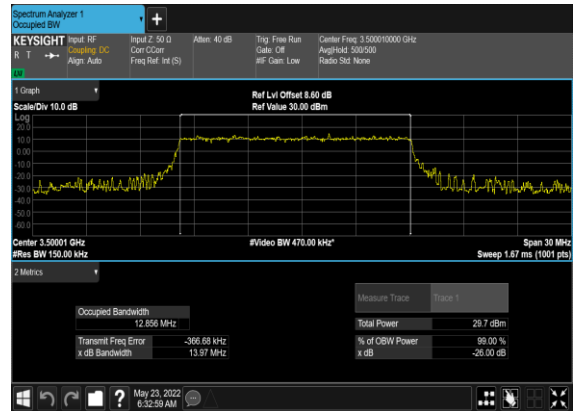

### N77(15M)\_CP-OFDM\_QPSK\_Outer\_Full\_Mid\_CH

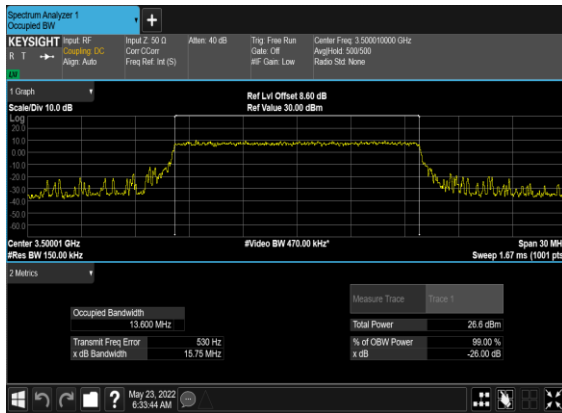

### N77(15M)\_CP-OFDM\_16QAM\_Outer\_Full\_Mid\_CH



### N77(15M)\_CP-OFDM\_64QAM\_Outer\_Full\_Mid\_CH

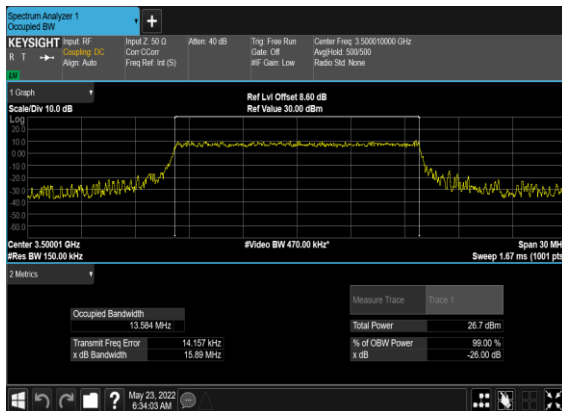

### N77(15M)\_CP-OFDM\_256QAM\_Outer\_Full\_Mid\_CH

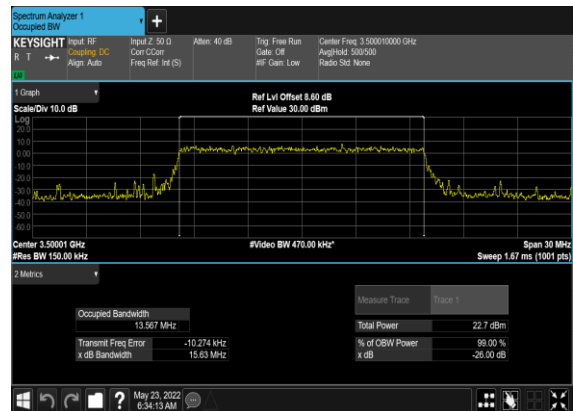

N77(20M)\_DFT-s-OFDM\_PI\_2-BPSK\_Outer\_Full\_Mid\_CH

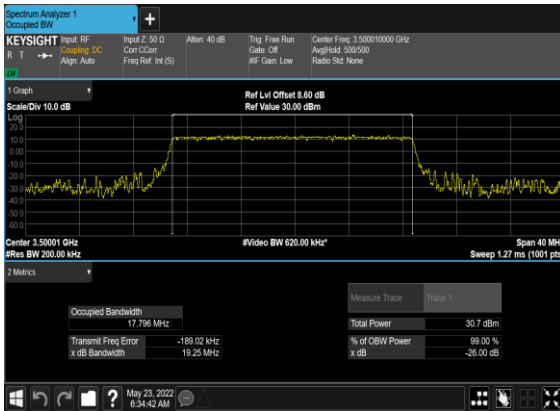

N77(20M)\_DFT-s-OFDM\_QPSK\_Outer\_Full\_Mid\_CH

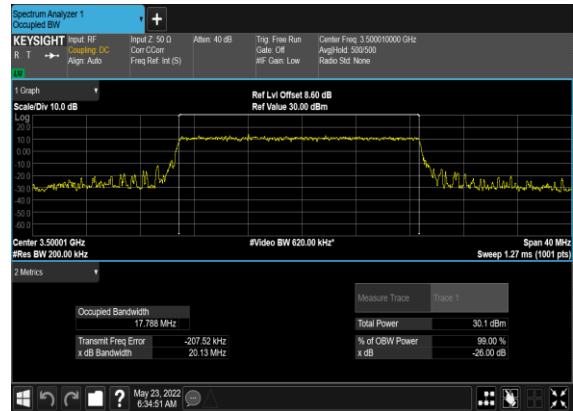

N77(20M)\_CP-OFDM\_QPSK\_Outer\_Full\_Mid\_CH



N77(20M)\_CP-OFDM\_16QAM\_Outer\_Full\_Mid\_CH



N77(20M)\_CP-OFDM\_64QAM\_Outer\_Full\_Mid\_CH

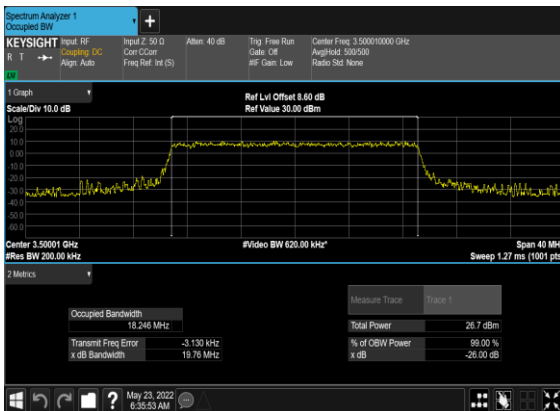

N77(20M)\_CP-OFDM\_256QAM\_Outer\_Full\_Mid\_CH

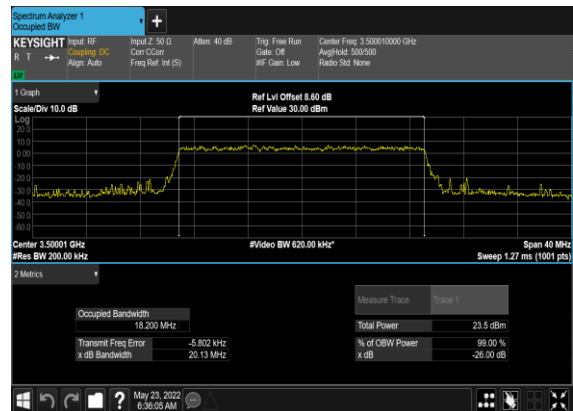



### N77(30M)\_DFT-s-OFDM\_PI\_2- BPSK\_Outer\_Full\_Mid\_CH

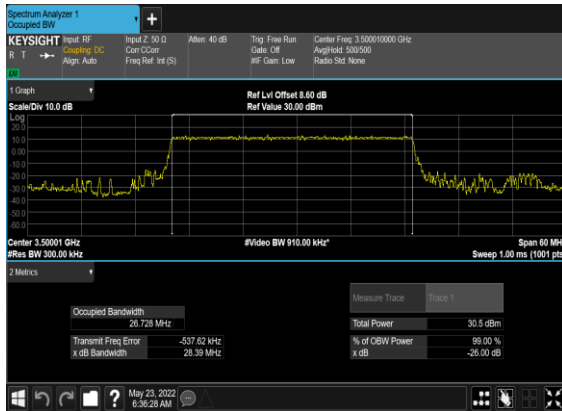

### N77(30M)\_DFT-s- OFDM\_QPSK\_Outer\_Full\_Mid\_CH

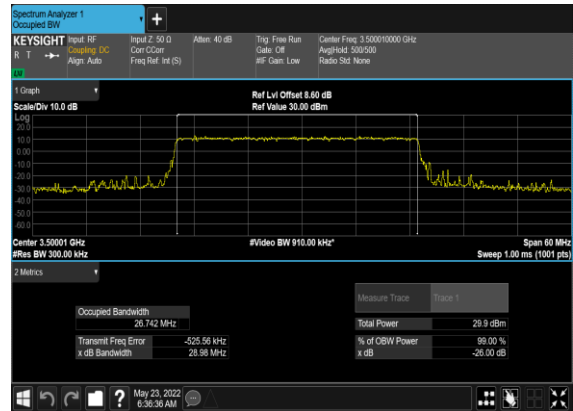

### N77(30M)\_CP- OFDM\_QPSK\_Outer\_Full\_Mid\_CH



### N77(30M)\_CP-OFDM\_16 QAM\_Outer\_Full\_Mid\_CH

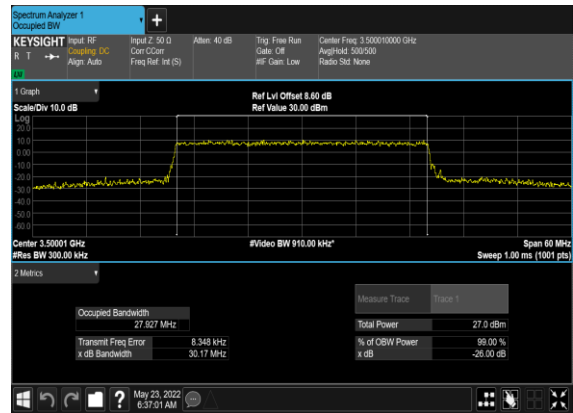

### N77(30M)\_CP-OFDM\_64 QAM\_Outer\_Full\_Mid\_CH

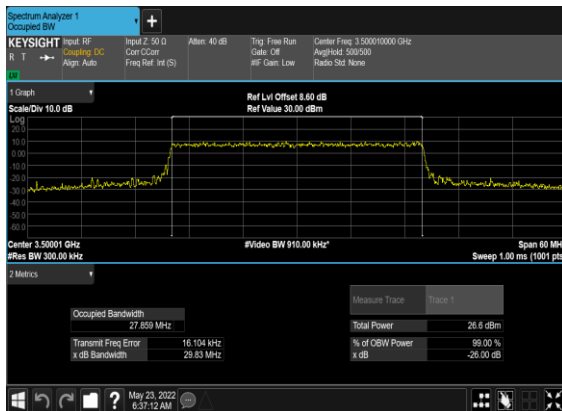

### N77(30M)\_CP-OFDM\_256 QAM\_Outer\_Full\_Mid\_CH

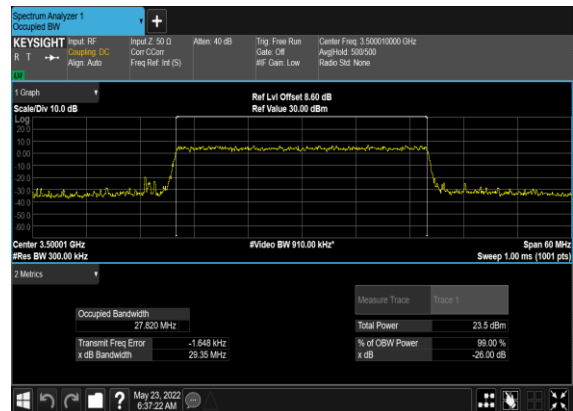

### N77(40M)\_DFT-s-OFDM\_PI\_2-BPSK\_Outer\_Full\_Mid\_CH

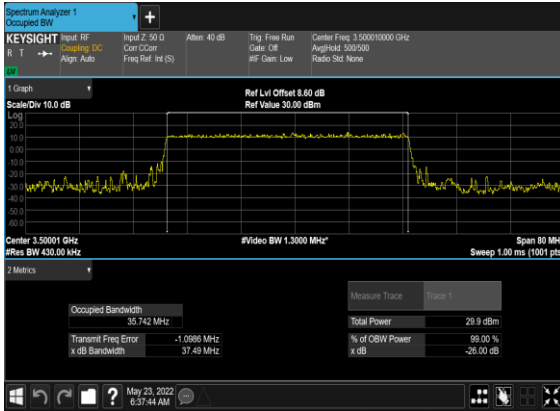

### N77(40M)\_DFT-s-OFDM\_QPSK\_Outer\_Full\_Mid\_CH

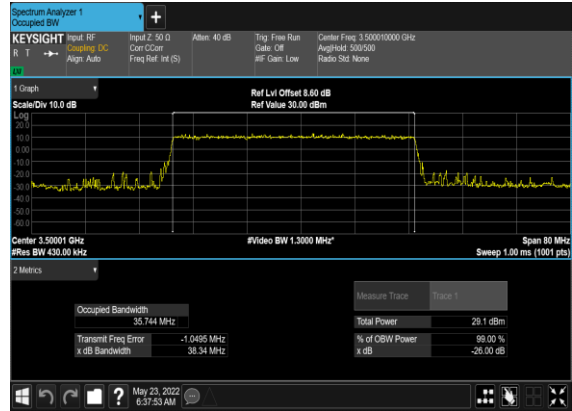

### N77(40M)\_CP-OFDM\_QPSK\_Outer\_Full\_Mid\_CH

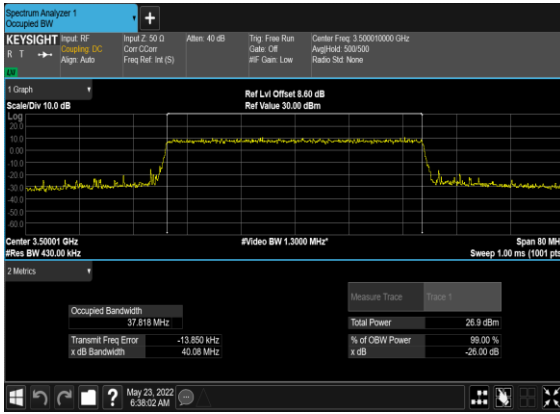

### N77(40M)\_CP-OFDM\_16QAM\_Outer\_Full\_Mid\_CH

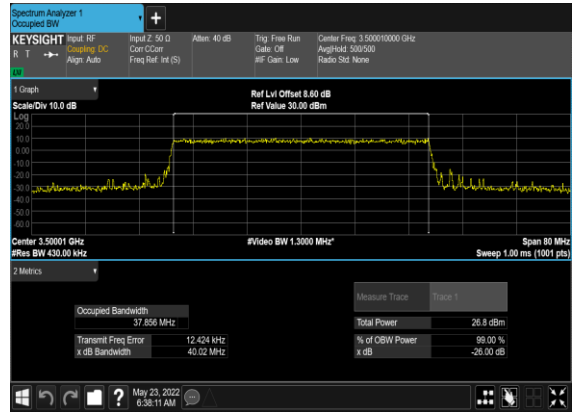

### N77(40M)\_CP-OFDM\_64QAM\_Outer\_Full\_Mid\_CH

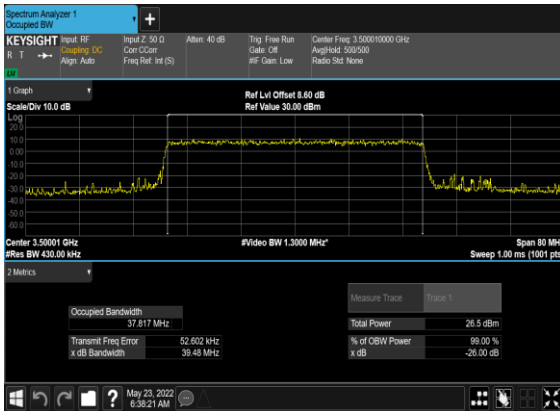

### N77(40M)\_CP-OFDM\_256QAM\_Outer\_Full\_Mid\_CH

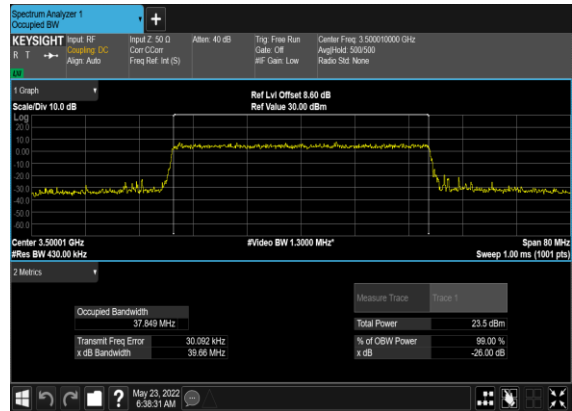

### N77(50M)\_DFT-s-OFDM\_PI\_2-BPSK\_Outer\_Full\_Mid\_CH

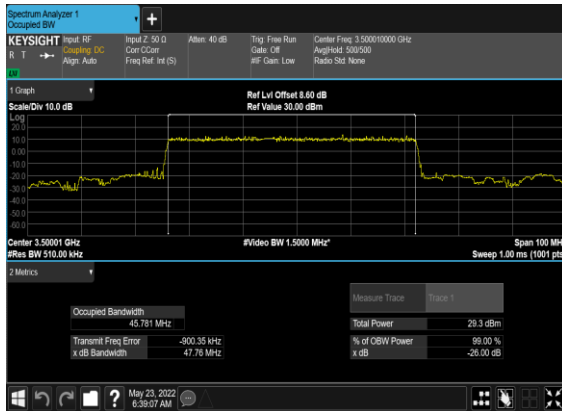

### N77(50M)\_DFT-s-OFDM\_QPSK\_Outer\_Full\_Mid\_CH

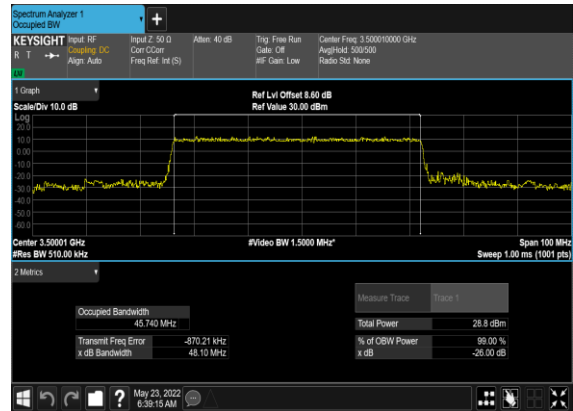

### N77(50M)\_CP-OFDM\_QPSK\_Outer\_Full\_Mid\_CH

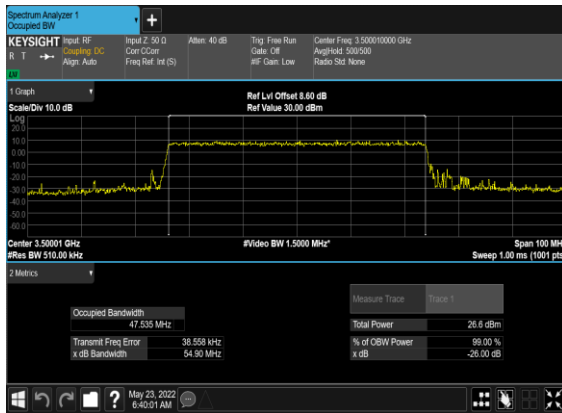

### N77(50M)\_CP-OFDM\_16QAM\_Outer\_Full\_Mid\_CH

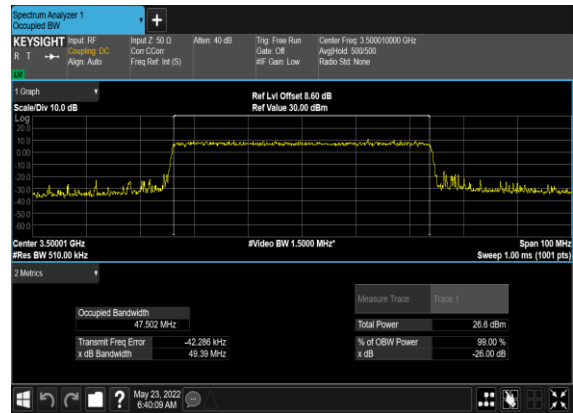

### N77(50M)\_CP-OFDM\_64QAM\_Outer\_Full\_Mid\_CH

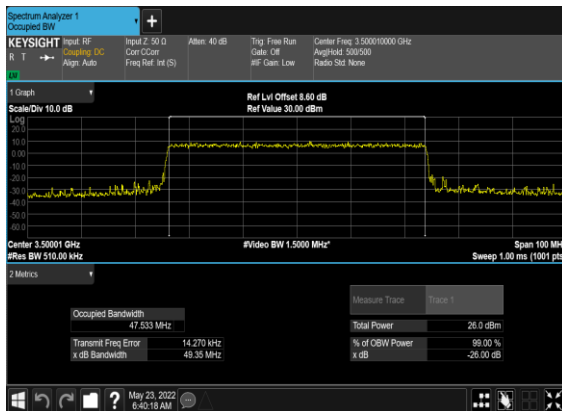

### N77(50M)\_CP-OFDM\_256QAM\_Outer\_Full\_Mid\_CH

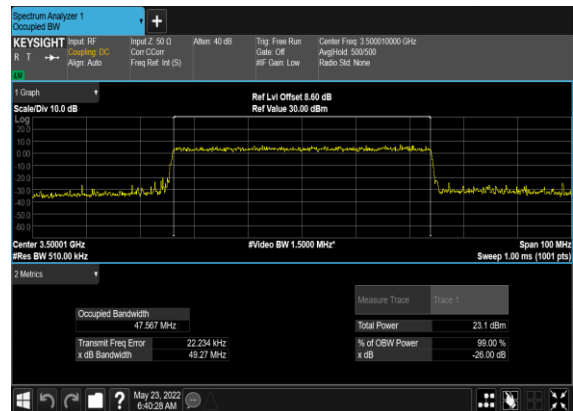

### N77(60M)\_DFT-s-OFDM\_PI\_2-BPSK\_Outer\_Full\_Mid\_CH

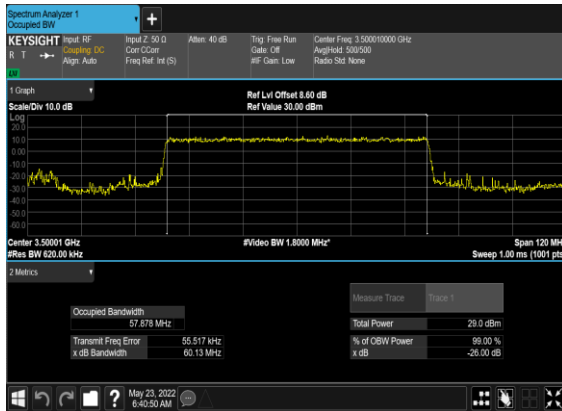

### N77(60M)\_DFT-s-OFDM\_QPSK\_Outer\_Full\_Mid\_CH

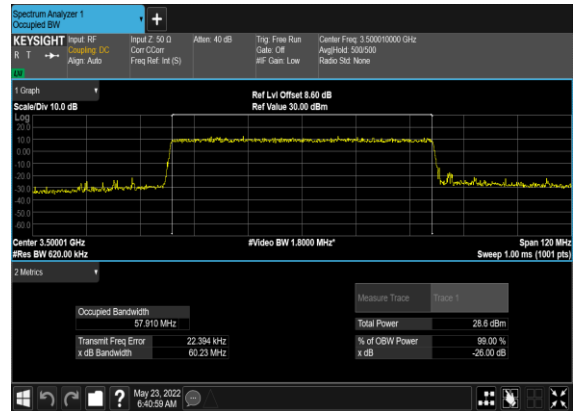

### N77(60M)\_CP-OFDM\_QPSK\_Outer\_Full\_Mid\_CH

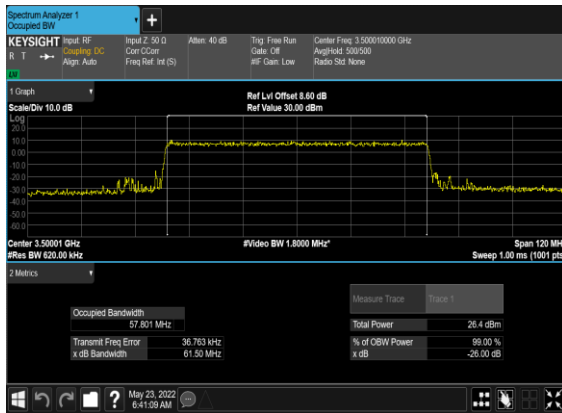

### N77(60M)\_CP-OFDM\_16QAM\_Outer\_Full\_Mid\_CH

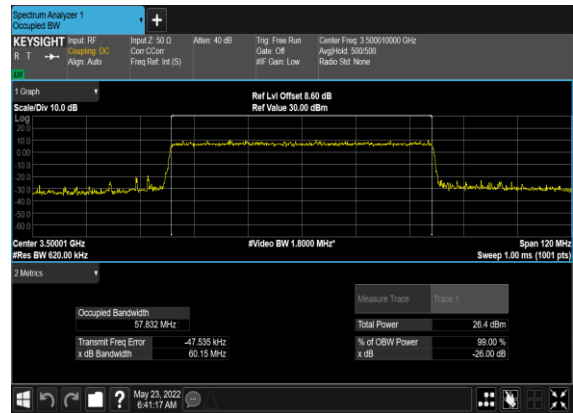

### N77(60M)\_CP-OFDM\_64QAM\_Outer\_Full\_Mid\_CH

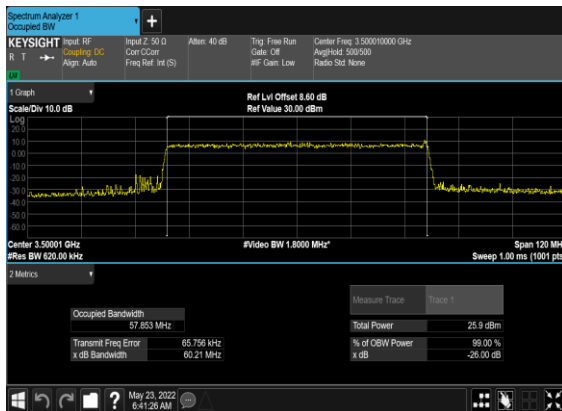

### N77(60M)\_CP-OFDM\_256QAM\_Outer\_Full\_Mid\_CH

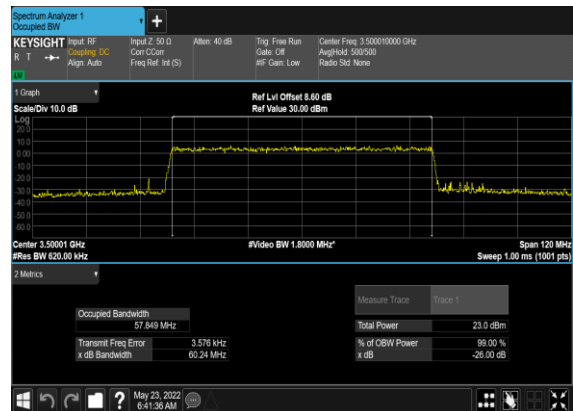

### N77(70M)\_DFT-s-OFDM\_PI\_2-BPSK\_Outer\_Full\_Mid\_CH

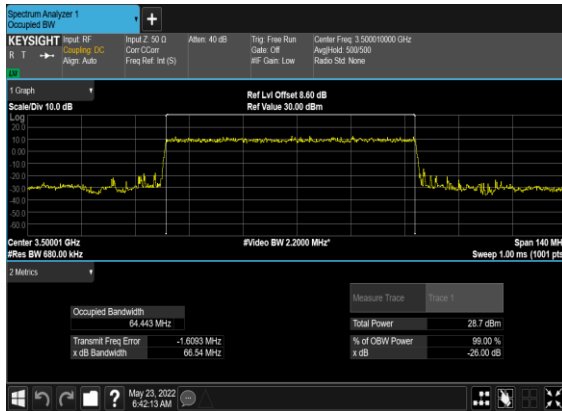

### N77(70M)\_DFT-s-OFDM\_QPSK\_Outer\_Full\_Mid\_CH

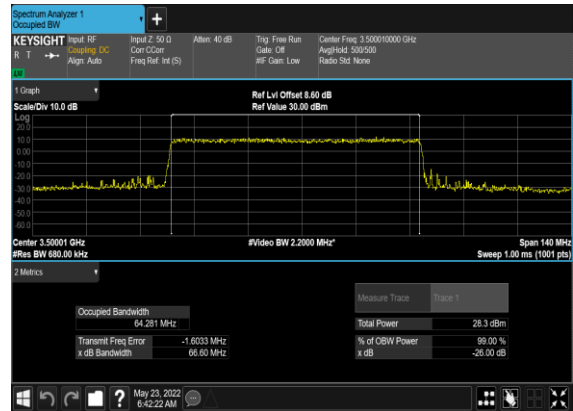

### N77(70M)\_CP-OFDM\_QPSK\_Outer\_Full\_Mid\_CH

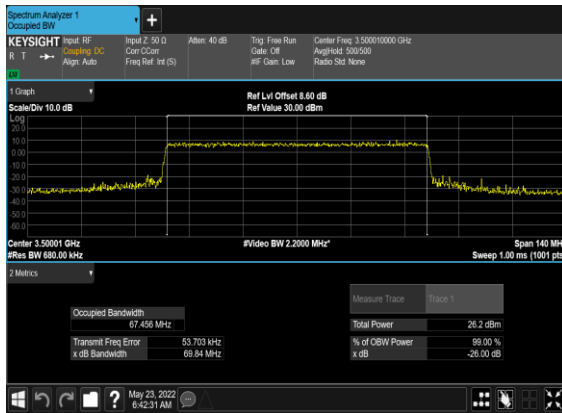

### N77(70M)\_CP-OFDM\_16QAM\_Outer\_Full\_Mid\_CH

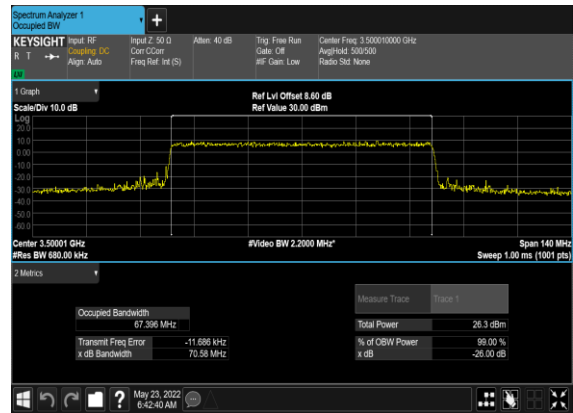

### N77(70M)\_CP-OFDM\_64QAM\_Outer\_Full\_Mid\_CH

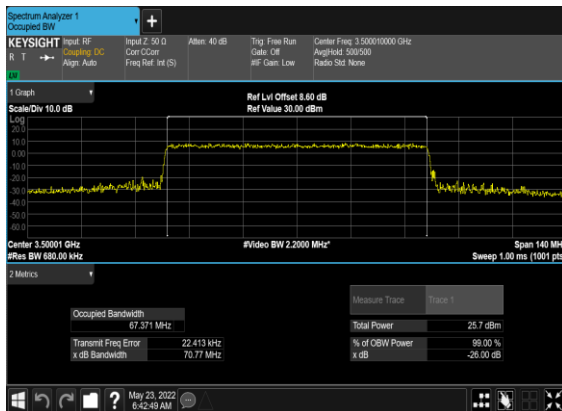

### N77(70M)\_CP-OFDM\_256QAM\_Outer\_Full\_Mid\_CH

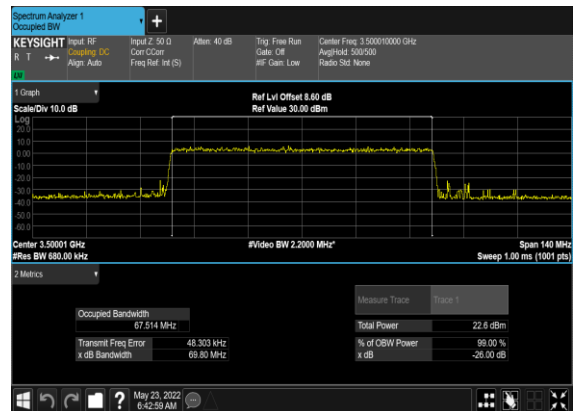

N77(80M)\_DFT-s-OFDM\_PI\_2-BPSK\_Outer\_Full\_Mid\_CH

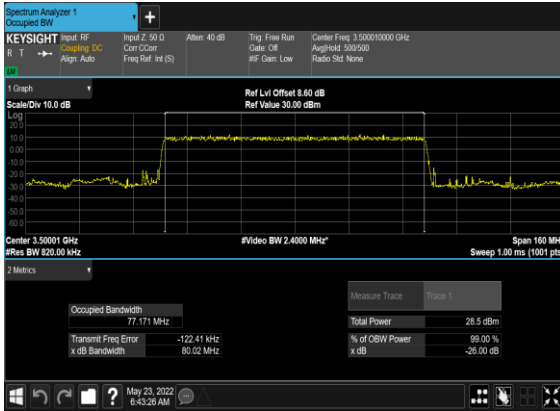

N77(80M)\_DFT-s-OFDM\_QPSK\_Outer\_Full\_Mid\_CH

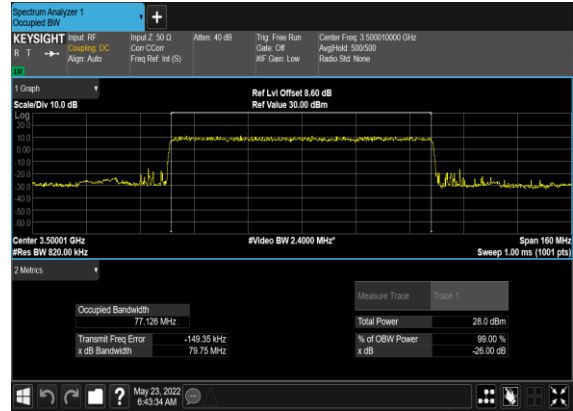

N77(80M)\_CP-OFDM\_QPSK\_Outer\_Full\_Mid\_CH



N77(80M)\_CP-OFDM\_16QAM\_Outer\_Full\_Mid\_CH

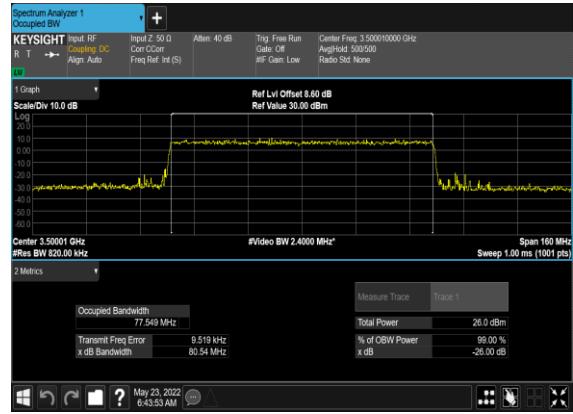

N77(80M)\_CP-OFDM\_64QAM\_Outer\_Full\_Mid\_CH

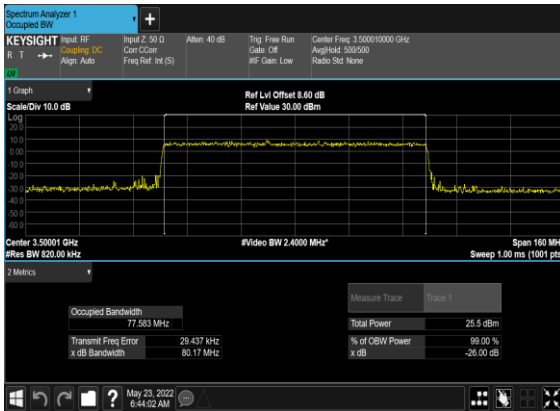

N77(80M)\_CP-OFDM\_256QAM\_Outer\_Full\_Mid\_CH

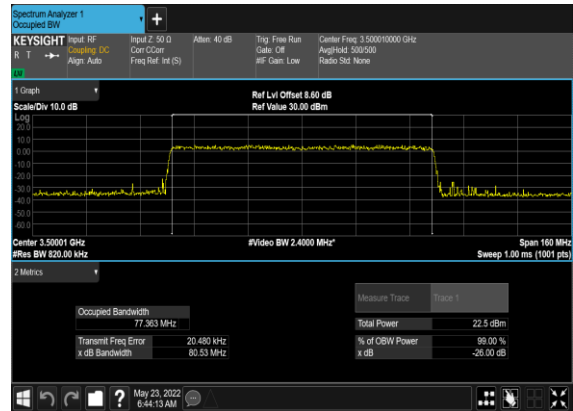

### N77(90M)\_DFT-s-OFDM\_PI\_2-BPSK\_Outer\_Full\_Mid\_CH

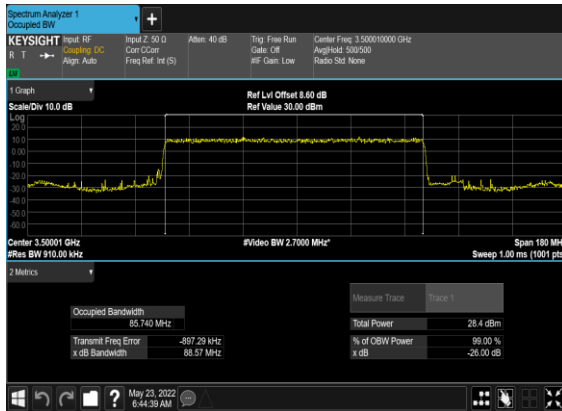

### N77(90M)\_DFT-s-OFDM\_QPSK\_Outer\_Full\_Mid\_CH

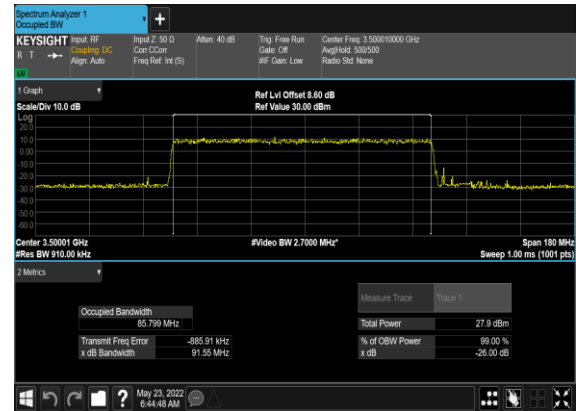

### N77(90M)\_CP-OFDM\_QPSK\_Outer\_Full\_Mid\_CH

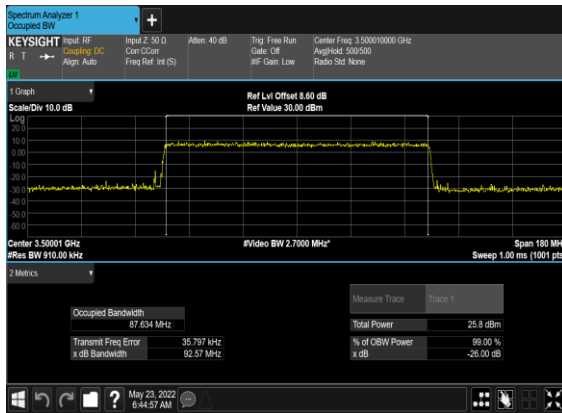

### N77(90M)\_CP-OFDM\_16QAM\_Outer\_Full\_Mid\_CH

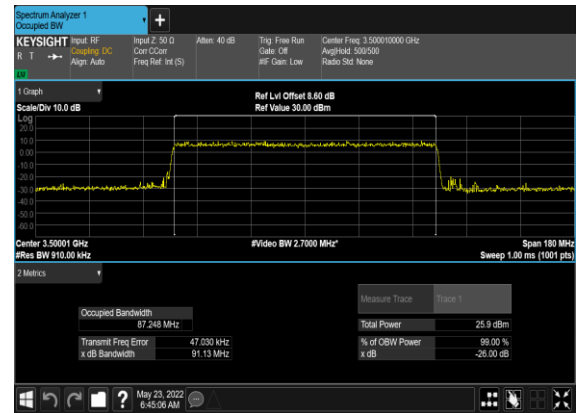

### N77(90M)\_CP-OFDM\_64QAM\_Outer\_Full\_Mid\_CH

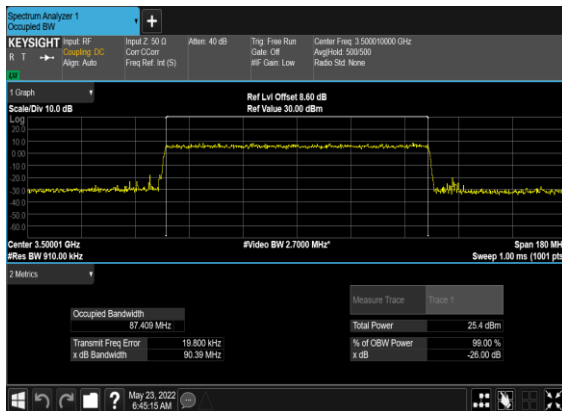

### N77(90M)\_CP-OFDM\_256QAM\_Outer\_Full\_Mid\_CH

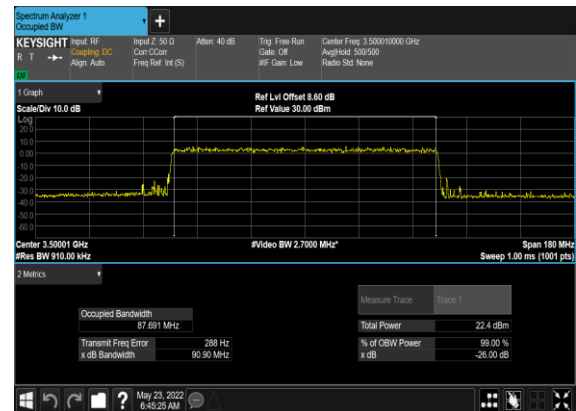

### N77(100M)\_DFT-s-OFDM\_PI\_2- BPSK\_Outer\_Full\_Mid\_CH

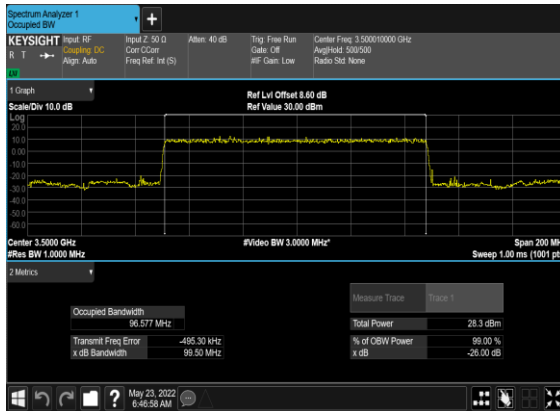

### N77(100M)\_DFT-s- OFDM\_QPSK\_Outer\_Full\_Mid\_CH

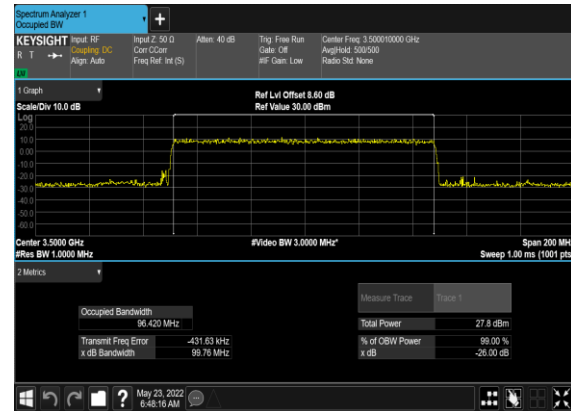

### N77(100M)\_CP- OFDM\_QPSK\_Outer\_Full\_Mid\_CH

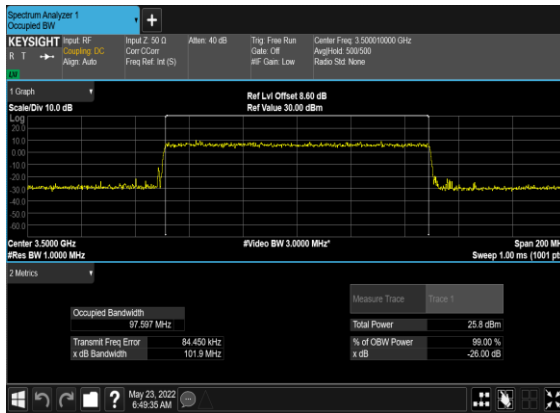

### N77(100M)\_CP-OFDM\_16 QAM\_Outer\_Full\_Mid\_CH

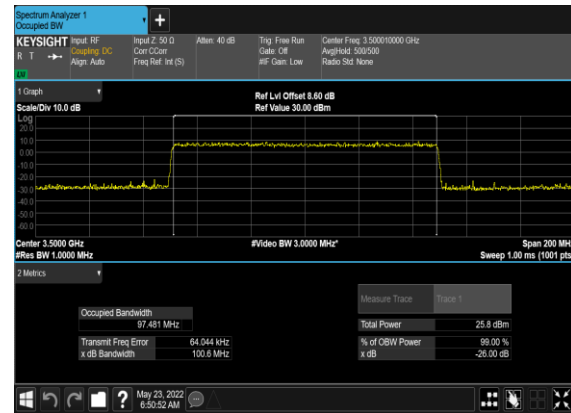

### N77(100M)\_CP-OFDM\_64 QAM\_Outer\_Full\_Mid\_CH

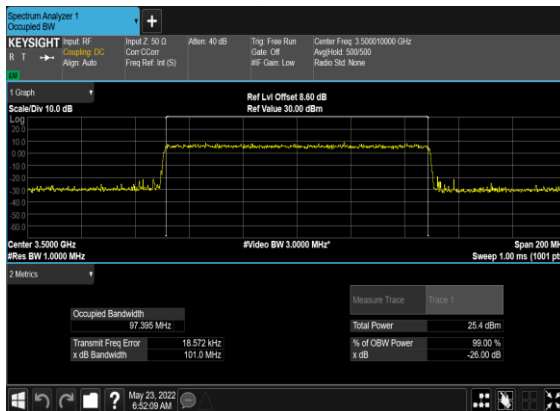

### N77(100M)\_CP-OFDM\_256 QAM\_Outer\_Full\_Mid\_CH

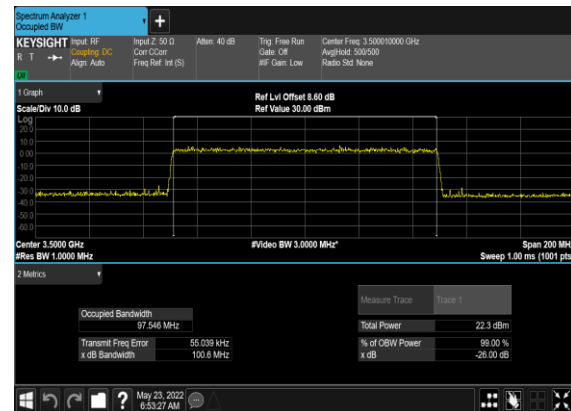



## Conducted Spurious Emissions

NR Band	SCS (kHz)	Bandwidth (MHz)	Arfcn	Freq (MHz)	Modulation	RB	Result	Verdict
77	30	10	630334	3455.01	DFT-s-OFDM BPSK	1@0	see graph	---
77	30	10	630334	3455.01	DFT-s-OFDM BPSK	1@0	see graph	<b>PASS</b>
77	30	10	630334	3455.01	DFT-s-OFDM BPSK	1@0	see graph	<b>PASS</b>
77	30	10	630334	3455.01	DFT-s-OFDM QPSK	1@0	see graph	---
77	30	10	630334	3455.01	DFT-s-OFDM QPSK	1@0	see graph	<b>PASS</b>
77	30	10	630334	3455.01	DFT-s-OFDM QPSK	1@0	see graph	<b>PASS</b>
77	30	10	633334	3500.01	DFT-s-OFDM BPSK	1@0	see graph	---
77	30	10	633334	3500.01	DFT-s-OFDM BPSK	1@0	see graph	<b>PASS</b>
77	30	10	633334	3500.01	DFT-s-OFDM BPSK	1@0	see graph	<b>PASS</b>
77	30	10	633334	3500.01	DFT-s-OFDM QPSK	1@0	see graph	---
77	30	10	633334	3500.01	DFT-s-OFDM QPSK	1@0	see graph	<b>PASS</b>
77	30	10	633334	3500.01	DFT-s-OFDM QPSK	1@0	see graph	<b>PASS</b>
77	30	10	636332	3544.98	DFT-s-OFDM BPSK	1@0	see graph	---
77	30	10	636332	3544.98	DFT-s-OFDM BPSK	1@0	see graph	<b>PASS</b>
77	30	10	636332	3544.98	DFT-s-OFDM BPSK	1@0	see graph	<b>PASS</b>
77	30	10	636332	3544.98	DFT-s-OFDM QPSK	1@0	see graph	---
77	30	10	636332	3544.98	DFT-s-OFDM QPSK	1@0	see graph	<b>PASS</b>
77	30	10	636332	3544.98	DFT-s-OFDM QPSK	1@0	see graph	<b>PASS</b>
77	30	50	631668	3475.02	DFT-s-OFDM BPSK	1@0	see graph	---
77	30	50	631668	3475.02	DFT-s-OFDM BPSK	1@0	see graph	<b>PASS</b>
77	30	50	631668	3475.02	DFT-s-OFDM BPSK	1@0	see graph	<b>PASS</b>
77	30	50	631668	3475.02	DFT-s-OFDM QPSK	1@0	see graph	---

77	30	50	631668	3475.02	DFT-s-OFDM QPSK	1@0	see graph	<b>PASS</b>
77	30	50	631668	3475.02	DFT-s-OFDM QPSK	1@0	see graph	<b>PASS</b>
77	30	50	633334	3500.01	DFT-s-OFDM BPSK	1@0	see graph	---
77	30	50	633334	3500.01	DFT-s-OFDM BPSK	1@0	see graph	<b>PASS</b>
77	30	50	633334	3500.01	DFT-s-OFDM BPSK	1@0	see graph	<b>PASS</b>
77	30	50	633334	3500.01	DFT-s-OFDM QPSK	1@0	see graph	---
77	30	50	633334	3500.01	DFT-s-OFDM QPSK	1@0	see graph	<b>PASS</b>
77	30	50	633334	3500.01	DFT-s-OFDM QPSK	1@0	see graph	<b>PASS</b>
77	30	50	635000	3525.0	DFT-s-OFDM BPSK	1@0	see graph	---
77	30	50	635000	3525.0	DFT-s-OFDM BPSK	1@0	see graph	<b>PASS</b>
77	30	50	635000	3525.0	DFT-s-OFDM BPSK	1@0	see graph	<b>PASS</b>
77	30	50	635000	3525.0	DFT-s-OFDM QPSK	1@0	see graph	---
77	30	50	635000	3525.0	DFT-s-OFDM QPSK	1@0	see graph	<b>PASS</b>
77	30	50	635000	3525.0	DFT-s-OFDM QPSK	1@0	see graph	<b>PASS</b>
77	30	100	633334	3500.01	DFT-s-OFDM BPSK	1@0	see graph	---
77	30	100	633334	3500.01	DFT-s-OFDM BPSK	1@0	see graph	<b>PASS</b>
77	30	100	633334	3500.01	DFT-s-OFDM BPSK	1@0	see graph	<b>PASS</b>
77	30	100	633334	3500.01	DFT-s-OFDM QPSK	1@0	see graph	---
77	30	100	633334	3500.01	DFT-s-OFDM QPSK	1@0	see graph	<b>PASS</b>
77	30	100	633334	3500.01	DFT-s-OFDM QPSK	1@0	see graph	<b>PASS</b>

### N77(10M)\_DFT-s-OFDM\_BPSK\_Edge\_1RB\_Left\_Low\_CH

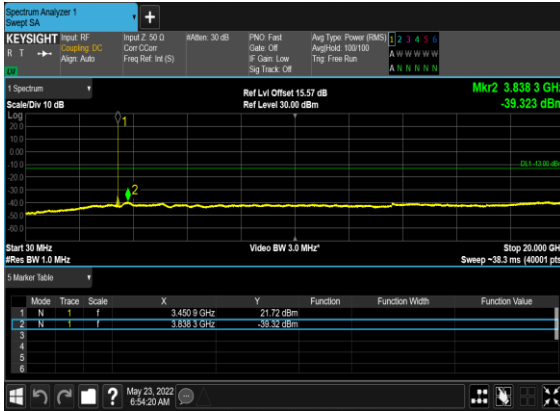

### N77(10M)\_DFT-s-OFDM\_BPSK\_Edge\_1RB\_Left\_Low\_CH

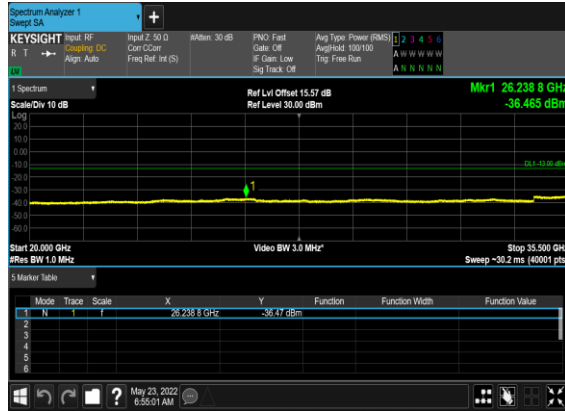

### N77(10M)\_DFT-s-OFDM\_QPSK\_Edge\_1RB\_Left\_Low\_CH

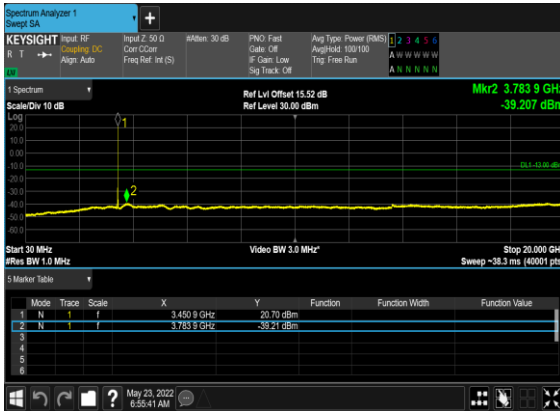

### N77(10M)\_DFT-s-OFDM\_QPSK\_Edge\_1RB\_Left\_Low\_CH

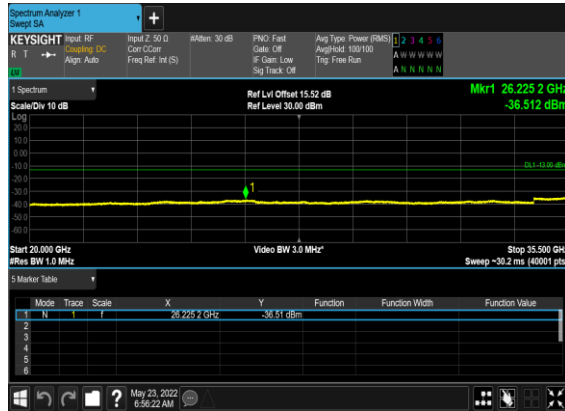

### N77(10M)\_DFT-s-OFDM\_BPSK\_Edge\_1RB\_Left\_Mid\_CH

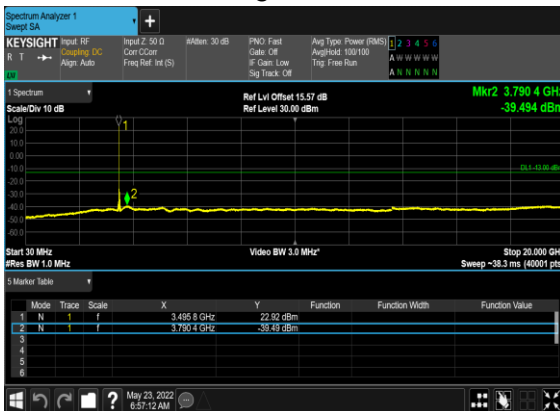

### N77(10M)\_DFT-s-OFDM\_BPSK\_Edge\_1RB\_Left\_Mid\_CH

