

MEASUREMENT REPORT
of
WLAN and Bluetooth Pocket PC

Applicant : ASUSTek Computer Inc.
EUT : ASUS MyPal A730 Pocket PC
Model No. : A730
FCC ID : MSQA730
Report No. : A5415597

Tested by :

Training Research Co., Ltd.

TEL : 886-2-26935155

FAX : 886-2-26934440

No. 255, Nanyang Street, Shijr, Taipei Hsien 221, Taiwan, R.O.C.

CERTIFICATION

We here by verify that:

The test data, data evaluation, test procedures and equipment configurations shown in this report were made mainly in accordance with the procedures given in ANSI C63.4 (1992) as a reference. All test were conducted by *Training Research Co., Ltd.*, 255 Nanyang Street, Shijr, Taipei Hsien 221, Taiwan, R.O.C. Also, we attest to the accuracy of each.

We further submit that the energy emitted by the sample EUT tested as described in the report is **in compliance with** the technical requirements set forth in the FCC Rules Part 15 Subpart B (Declaration of Conformity) and C Section 15.247.

Applicant : ASUSTek Computer Inc.
Applicant address : 4Fl., No. 150, Li-Te Rd., Peitou, Taipei, Taiwan
Product Name : ASUS MyPal A730 Pocket PC
Model Name : A730
FCC ID : MSQA730
Report No. : A5415597
Test Date : June 28, 2004

Prepared by:

Jack Tsai

Approved by:

Frank Tsai

Conditions of issue :

- (1) **This test report shall not be reproduced except in full, without written approval of TRC. And the test result contained within this report only relate to the sample submitted for testing.**
- (2) **This report must not be used by the client to claim product endorsement by NVLAP or any agency of U.S. Government.**
- (3) **This test report, measurements made by TRC are traceable to the NIST only Conducted and Radiated Method.**

★ NVLAP LAB CODE: 200174-0

Federal Communications Commission **Declaration of Conformity** **(DoC)**

For the Following Equipment:

Product name : ASUS MyPal A730 Pocket PC
Model name : A730
Trade name : ASUS

Is herewith confirmed and found to comply with the requirements of CFR 47 part15 Subpart B - Unintentional Radiators regulation. The results of electromagnetic mission evaluation are shown in the report number : A5415597

This device complies with Part 15 of the FCC Rules. Operation is subject to the following two conditions:

- (1) This device may not cause harmful interference, and
- (2) This device must accept any interference received,
 including interference that may cause undesired operation

<i>Manufacturer</i>	<i>USA local representative</i>
Company name: ASUSTeK Computer Inc.	To be determined
Computer address: 4/F, 150, Li-Te Rd., Peitou, Taipei, Taiwan	
ZIP / Postal code: 112	
Contact person: Lawrence Yu	
Title: Manager	
Internet e-mail address: Lawrence_yu@asus.com.tw	
Tel / Fax: 886-2-28943447 / 886-2-28950113	

Tables of Contents

I. GENERAL	6
1.1 Introduction	6
1.2 Description of EUT	6
1.3 Test method	6
1.4 Description of Support Equipment	7
1.5 Configuration of System Under Test	10
1.6 Verify the Frequency and Channel	13
1.7 Test Procedure	14
1.8 Location of the Test Site	14
1.9 General Test Condition	14
II. Section 15.101(a) : Equipment Authorization of Unintentional Radiators	15
III. Section 15.203 : Antenna Requirement	16
IV. Section 15.207 : Power Line Conducted Emissions for AC Powered Units	17
4.1 Test Condition & Setup	17
4.2 List of Test Instruments	18
4.3 Test Result of Conducted Emissions	19
RX mode	19
WLAN Channel 01	20
WLAN Channel 06	21
WLAN Channel 11	22
WLAN+BT	23
V. Section 15.247(a) : Technical Description of the EUT	24

- VI. Section 15.247(a)(2) : Bandwidth for Direct Sequence System** 25
 - 6.1 Test Condition & Setup 25
 - 6.2 Test Instruments Configuration 25
 - 6.3 List of Test Instruments 25
 - 6.4 Test Result of Bandwidth 25
 - Channel 01 26
 - Channel 06 26
 - Channel 11 27

- VII. Section 15.247(b) : Power Output** 28
 - 7.1 Test Condition & Setup 28
 - 7.2 List of Test Instruments 28
 - 7.3 Test Result 28

- VIII. Section 15.247(c) : Spurious Emissions (Radiated)** 29
 - 8.1 Test Condition & Setup 29
 - 8.2 List of Test Instruments 31
 - 8.3 Test Result of Spurious Radiated Emissions 32
 - RX mode 32
 - WLAN + BT 33
 - WLAN Channel 01 34
 - WLAN Channel 06 36
 - WLAN Channel 11 38
 - 8.4 Test Result of Bandedge 40
 - Channel 01 41
 - Channel 11 42

- IX. Section 15.247(d) : Power Spectral Density** 43
 - 9.1 Test Condition & Setup 43
 - 9.2 Test Instruments Configuration 43
 - 9.3 List of Test Instruments..... 43
 - 9.4 Test Result of Power Spectral Density 43
 - Channel 01 44
 - Channel 06 44
 - Channel 11 45

I . GENERAL

1.1 Introduction

The following measurement report is submitted on behalf of applicant in support that the certification in accordance with Part 2 Subpart J and Part 15 Subpart A, B and C of the Commission's Rules and Regulations.

1.2 Description of EUT

FCC ID	:	MSQA730
Product Name	:	ASUS MyPal A730 Pocket PC
Model Name	:	A730
Frequency Range	:	2412MHz to 2462MHz
Support Channel	:	11 Channels
Channel Spacing	:	5 MHz
Modulation Skill	:	DBPSK / DQPSK / CCK
Power Type	:	(1) Battery-powered by the client's device, or (2) Power adapter Manufacture: PIE Model: AD3110 I/P: 100-240VAC, 50-60Hz, 0.36-0.2A ; O/P: 5VDC, 2.4A Power cable: (between AC source and adapter) 183cm length, non-shielded, no ferrite core Power cable: (between adapter and cradle) 154cm length, non-shielded, no ferrite core
Data Cable	:	USB cable: 110cm length, shielded, no ferrite core

1.3 Test method

A) PDA with Cradle (Power jack in cradle):

- (1) Put the PDA into the cradle.
- (2) The POWER jack of cradle is connected with the AC power source via a power adaptor.
- (3) The USB jack of cradle is connected with the USB cable to USB port of PC.
- (4) The HEADPHONE jack of PDA is connected with the earphone.

B) PDA with Cradle (Power jack in sync cable):

- (5) Put the PDA into the cradle.
- (6) The POWER jack of sync cable adaptor is connected with the AC power source via a power adaptor.
- (7) The USB jack of cradle is connected with the USB cable to USB port of PC.
- (8) The HEADPHONE jack of PDA is connected with the earphone.

C) PDA without Cradle:

- (9) The 26-pin connector of PDA body is connected with the USB port of PC via the sync cable.
- (10) The POWER jack of sync cable is connected with the AC power source via a power adaptor.
- (11) The HEADPHONE jack of PDA is connected with the earphone.

Notes: A, B and C modes were pre-tested, the B mode worst case one, was chosen for final test.

D) PDA only: (EUT Stand on three orthogonal planes respectively, record worst-case in report)

- (12) The HEADPHONE jack of PDA is connected with the earphone.
- (13) Powered by battery.
- (14) Using PC and software provided by the applicant to linking EUT. The software is operated under the Windows to linking the EUT in the unintentional test.
- (15) Set different channel (CH1/CH6/CH11, co-location for Bluetooth) being tested and repeat the procedures above.
 - (a) Radiated for intentional test:
 - making EUT to the mode of continuous TX or RX
 - (b) Conducted and radiated for unintentional test:
 - making EUT to the linking mode with another PDA.

1.4 Description of Support Equipment

In order to construct the minimum testing, following equipment were used as the support units.

PC	: HP Pavilion 500
Model No.	: P8574A
Serial No.	: TW219204335
FCC ID	: N/A, DoC (Declaration of Confirmation) Approved
檢磁	: 3902H097
Power type	: 100 ~ 127/ 200 ~ 240VAC, 4A/2A 50/60 Hz, Switching
Power cord	: Non-shielded, 2.3m length, Plastic, No ferrite core
Monitor	: HP 15" Color Monitor
Model No.	: D2827A
Serial No.	: KR91161719
FCC ID	: C5F7NFCMC1518X
檢磁	: 3872B039
Power type	: 110 ~ 240 VAC / 50 ~ 60 Hz, Switching
Power cord	: Shielded, 1.83m long, No ferrite core
Data cable	: Shielded, 1.46m long, with two ferrite cores
Keyboard	: HP
Model No.	: 5181
Serial No.	: BE21700405
FCC ID	: Doc Approved
檢磁	: 3892C981
Power type	: By PC
Data cable	: Shielded, 1.70m length, with ferrite core
Mouse	: HP
Model No.	: M-UR89
Serial No.	: LZS21750238
FCC ID	: Doc Approved
檢磁	: 3892D767
Power type	: By PC
Power cord	: Shielded, 1.80m length, No ferrite core

USB

Gamepad:Rockfire

Model No. : QF-337uv
Serial No. : 10600545
FCC ID : None (CE approval)
檢磁 : 3862A574
Power type : By computer
Data Cable : Shielded, 1.81m long, Plastic, with ferrite core

Fax/Modem : Aceex

Model No. : DM-1414
Serial No. : 9010582
FCC ID : IFAXDM1414
Power type : 110 VAC / 50 ~ 60 Hz, Switching
Power Cord : Non-shielded, 1.90m long, Plastic hoods, and no ferrite bead
Data Cable : RS-232→Shielded, 1.30m long, Metal hoods , No bead
RJ-11Cx2→Non-shielded, 7' long, Plastic hoods, No bead

Printer : HP

Model No. : C6464A
Serial No. : TH16LEB5PK
FCC ID : N/A, DoC Approved
檢磁 : 3892H381
Power type : Switching adaptor
Power cord : Non-shielded, 173cm long, No ferrite core
(between adaptor and AC source)
Non-shielded, 180cm long, with ferrite core
(between printer and adaptor)
Data cable : Shielded, 1.70m long, No ferrite core

Stereo Earphones: Panasonic

Model No :RP-HV152
Serial No. :5 025232 242418
FCC ID :N/A
Power type :By EUT
Data Cable :Non-shielded, 1.1m length, Plastic hood, No ferrite core

CF card : NIKON

Model No. : EC-16CF
Serial No. : 4027012
FCC ID : Doc approval
Power type : By PDA

1.5 Configuration of System Under Test

1.5.1 Conducted and Radiated of Unintentional, with Cradle

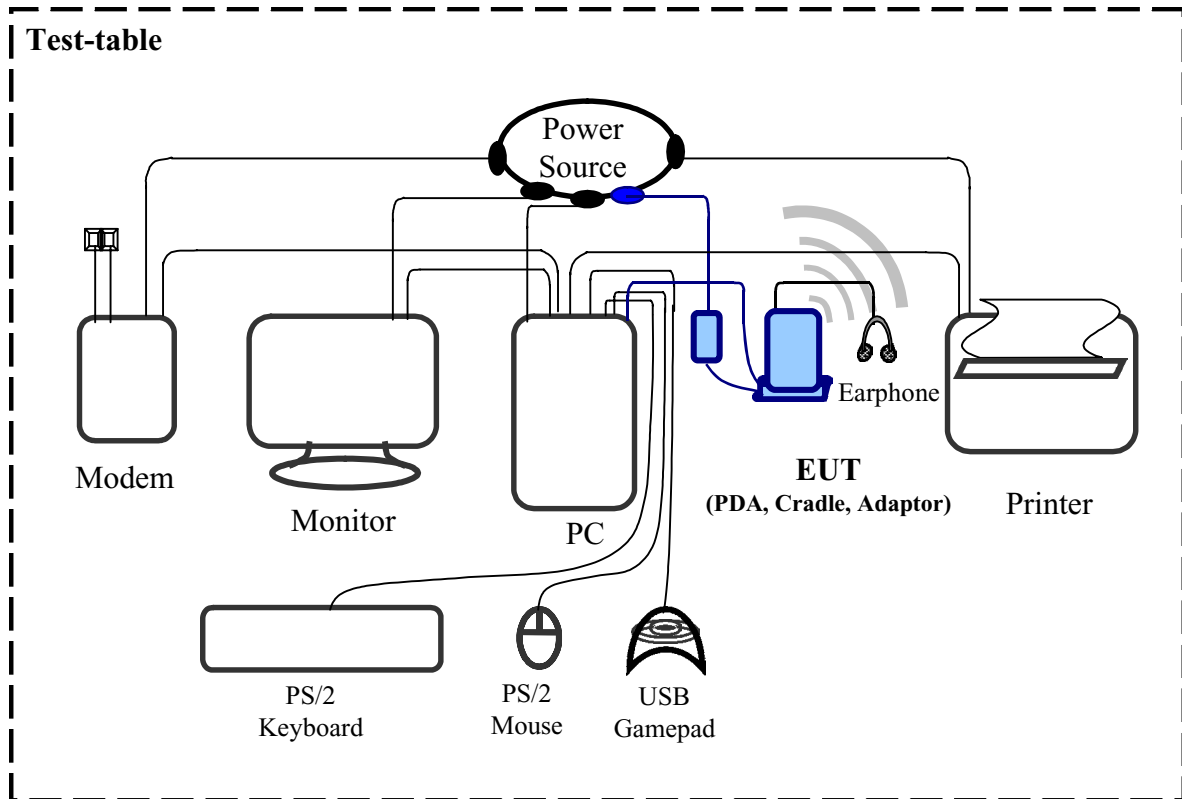

Connections of Equipment

PC:

- *VGA Port --- a monitor
- *Serial A-Port --- an external modem
- *Parallel Port --- a printer
- *PS/2 Ports --- a PS/2 keyboard and PS/2 mouse
- *USB A-Port --- a USB gamepad
- *USB B-Port --- EUT

EUT:

USB Cradle

- *Sync USB Cable x 1 --- 110cm length, shielded, no ferrite core

Switching Adaptor

- *Power Cable (between AC source and adaptor) x 1 --- 183cm length, non-shielded, no ferrite core
- *Power Cable (between adaptor and cradle) x 1 --- 154cm length, non-shielded, no ferrite core

Earphone:

- *Data cable x 1 --- 110cm length, non-shielded, no ferrite core

CF socket:

- *CF Card

1.5.2 Conducted and Radiated of Unintentional, without Cradle

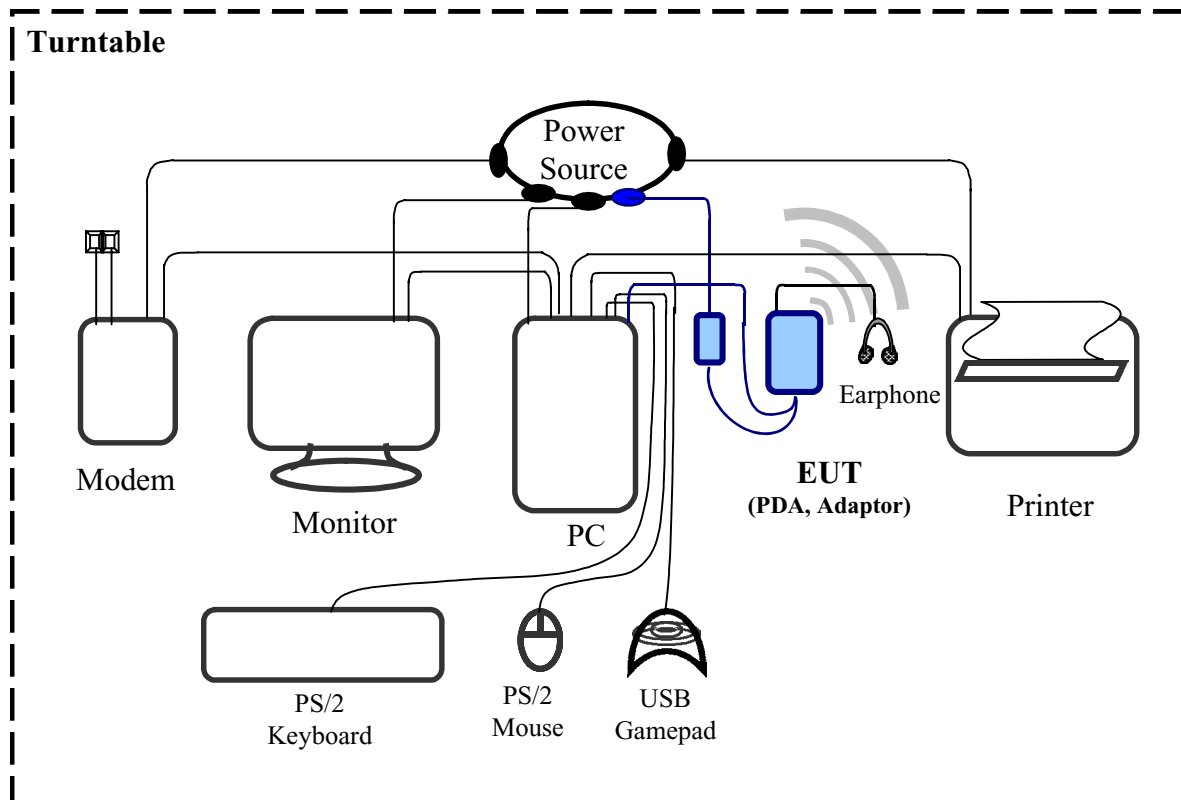

Connections of Equipment

PC:

- *VGA Port --- a monitor
- *Serial A-Port --- an external modem
- *Parallel Port --- a printer
- *PS/2 Ports --- a PS/2 keyboard and PS/2 mouse
- *USB A-Port --- a USB gamepad
- *USB B-Port --- EUT

EUT:

USB Cradle

- *USB Cable x 1 --- 110cm length, shielded, no ferrite core

Switching Adaptor

- *Power Cable (between AC source and adaptor) x 1 --- 183cm length, non-shielded, no ferrite core
- *Power Cable (between adaptor and cradle) x 1 --- 154cm length, non-shielded, no ferrite core

Earphone:

- *Data cable x 1 --- 110cm length, non-shielded, no ferrite core

1.5.3 Radiated of Intentional, PDA Only

Turntable

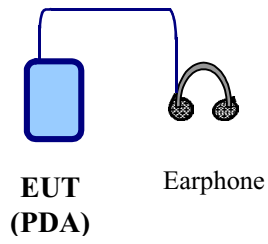
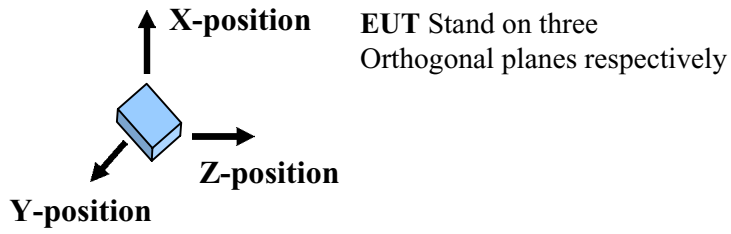

1.6 Verify the Frequency and Channel

Channel	Frequency (GHz)
1	2.412
2	2.417
3	2.422
4	2.427
5	2.432
6	2.437
7	2.442
8	2.447
9	2.452
10	2.457
11	2.462

Note:

1. This is for confirming that all frequencies are in 2.412GHz to 2.462GHz.
2. Section 15.31(m): Measurements on intentional radiators or receivers shall be performed at three frequencies for operating frequency range over 10 MHz.
(The locations of these frequencies one near the top, one near the middle and one near the bottom.)
3. After test, the EUT operating frequencies are in 2.412GHz to 2.462GHz. So all the items as followed in testing report are need to test these three frequencies:
Top: Channel – 1; Middle: Channel – 6; Bottom: Channel – 11.

1.7 Test Procedure

All measurements contained in this report were performed mainly according to the techniques described in ANSI C63.4 (1992) and the pre-setup was written on 1.3 test method, the detail setup was written on each test item.

1.8 Location of the Test Site

The radiated emissions measurements required by the rules were performed on the **three-meter, Anechoic Chamber (FCC Registration Number: 93906)** maintained by *Training Research Co., Ltd.* 1F, No. 255 Nanyang Street, Shijr, Taipei Hsien 221, Taiwan, R.O.C. Complete description and measurement data have been placed on file with the commission. The conducted power line emissions tests and other test items were performed in a anechoic chamber also located at Training Research Co., Ltd.

No. 255 Nanyang Street, Shijr, Taipei Hsien 221, Taiwan, R.O.C. *Training Research Co., Ltd.* is listed by the FCC as a facility available to do measurement work for others on a contract basis.

1.9 General Test Condition

The conditions under which the EUT operates were varied to determine their effect on the equipment's emission characteristics. The final configuration of the test system and the mode of operation used during these tests were chosen as that which produced the highest emission levels. However, only those conditions, which the EUT was considered likely to encounter in normal use were investigated.

In test, they were set in high power and continuously transmitting mode that controlled by computer. The ch01, ch06 and ch11 of EUT were all tested. The setting up procedure is recorded on 1.3 test method.

II. Section 15.101(a): Equipment authorization of unintentional radiators

The EUT equipped with a USB interface and should be operated with the computer. It was categorized to *Class B personal computers and peripherals* as cannot be operated stand-alone. The authorization requires **Declaration of Conformity (DoC)** and the items required such as Section 15.107 (Conducted limits) and Section 15.109 (Radiated emission limits) is same as Section 15.207 and 15.247(C).

III. Section 15.203: Antenna requirement

The EUT can be equipped with undetachable antenna. The internal antenna is affixed to the EUT using a unique connector, there is no external antenna or external connector employed. The antenna requirement stated in Section 15.203 is inapplicable to this EUT.

The custom antenna specification of list as below:

Manufacturer : WHA YU INDUSTRIAL CO., LTD.
Model : C660-520008-A
Antenna Type : Dipole Antenna
Antenna Gain : -1.2dBi (for WLAN Max.)

IV. Section 15.207: Power Line Conducted Emissions for AC Powered Units

4.1 Test Condition & Setup

The power line conducted emission measurements were performed in an anechoic chamber. The EUT was assembled on a wooden table, which is 80 centimeters high, was placed 40 centimeters from the backwall and at least 1 meter from the sidewall.

Power was fed to the EUT from the public utility power grid through a line filter and Line Impedance Stabilization Networks (LISNs). The LISN housing, measuring instrumentation case, ground plane, etc., were electrically bonded together at the same RF potential. The Spectrum analyzer (or EMI receiver) was connected to the AC line through an isolation transformer. The 50-ohm output of the LISN was connected to the spectrum analyzer directly. Conducted emission levels were in the CISPR quasi-peak and average detection mode. The analyzer's 6 dB bandwidth was set to 9 KHz. No post-detector video filter was used.

The spectrum was scanned from 150KHz to 30MHz. The physical arrangement of the test system and associated cabling was varied (within the scope of arrangements likely to be encountered in actual use) to determine the effect on the unit's emanations in amplitude and frequency. All spurious emission frequencies were observed. The highest emission amplitudes relative to the appropriate limit were measured and have been recorded in paragraph 4.3.

There is a test condition apply in this test item, the test procedure description as <1.3>. Three channels were tested, one in the top (CH01), one in the middle (CH06) and the other in bottom (CH11).

4.2 List of Test Instruments

Instrument Name	Model	Brand	Serial No.	<u>Calibration Date</u>
				Next time
EMI Receiver	8546A	HP	3520A00242	07/28/04
RF Filter Section	85460A	HP	3448A00217	07/28/04
LISN (EUT)	LISN-01	TRC	99-05	09/21/04
LISN (Support E.)	LISN-01	TRC	9912-03, 04	07/21/04
Pre-amplifier	15542 ZFL-500	Mini – Circuits	0 0117	05/20/05
6dB Attenuator	MCL BW-S6W2	Mini – Circuits	9915 – Conducted	05/20/05
10dB Attenuator	A5542 VAT010	Mini – Circuits	0215 – Conducted	05/20/05
Coaxial Cable (2 meter)	A30A30-0058-50FS-2M	Jyebao	SMA-08	05/20/05
Coaxial Cable (1.1 meter)	A30A30-0058-50FS-1M	Jyebao	SMA-09	05/20/05
Coaxial Cable (20 meter)	RG-214/U	Jyebao	NP-01	05/20/05
Coaxial Cable (20 meter)	RG-214/U	Jyebao	NP-02	05/20/05
Auto Switch Box (< 30MHz)	ASB-01	TRC	9904-01	05/20/05

4.3 Test Result of Power Line Conducted Emissions

The following table shows a summary of the highest emissions of power line conducted emissions on the LIVE and NETURAL conductors of the EUT power cord. Show as follows.

Test Conditions: Temperature : 25 °C Humidity : 73 % RH

Test Mode: (B) mode for RX

Power Connected Emissions					FCC Class B		
Conductor	Frequency (KHz)	Peak (dBµV)	QP (dBµV)	Average (dBµV)	QP-limit (dBµV)	AVG-limit (dBµV)	Margin (dB)
Line 1	305.000	32.01	---	---	61.57	51.57	-19.56
	499.000	26.78	---	---	56.03	46.03	-19.25
	681.000	29.60	---	---	56.00	46.00	-16.40
	788.000	31.04	---	---	56.00	46.00	-14.96
	902.000	28.42	---	---	56.00	46.00	-17.58
	10290.000	32.79	---	---	60.00	50.00	-17.21
	12060.000	45.83	---	---	60.00	50.00	-4.17
	16230.000	32.88	---	---	60.00	50.00	-17.12
	23900.420	47.38	41.50	33.66	60.00	50.00	-2.62
Line 2	300.000	41.37	---	---	61.71	51.71	-10.34
	598.000	34.64	---	---	56.00	46.00	-11.36
	893.000	40.86	---	---	56.00	46.00	-5.14
	1208.000	38.93	---	---	56.00	46.00	-7.07
	1503.000	35.21	---	---	56.00	46.00	-10.79
	1766.000	38.90	---	---	56.00	46.00	-7.10
	2094.000	37.71	---	---	56.00	46.00	-8.29
	2689.000	37.96	---	---	56.00	46.00	-8.04
	12000.000	46.90	---	---	60.00	50.00	-3.10
	23840.000	46.84	---	---	60.00	50.00	-3.16

NOTE:

- (1)Margin = Peak Amplitude – Limit, *The reading amplitudes are all under limit.*
- (2)A "+" sign in the margin column means the emission is OVER the Class B Limit and "-" sign of means UNDER the Class B limit

Test Mode: (B) Mode for WLAN CH01

<i>Power Connected Emissions</i>					<i>FCC Class B</i>		
<i>Conductor</i>	<i>Frequency (KHz)</i>	<i>Peak (dBμV)</i>	<i>QP (dBμV)</i>	<i>Average (dBμV)</i>	<i>QP-limit (dBμV)</i>	<i>AVG-limit (dBμV)</i>	<i>Margin (dB)</i>
Line 1	297.000	38.67	---	---	61.80	51.80	-13.13
	592.000	34.21	---	---	56.00	46.00	-11.79
	884.000	30.47	---	---	56.00	46.00	-15.53
	1176.000	33.03	---	---	56.00	46.00	-12.97
	1490.000	31.09	---	---	56.00	46.00	-14.91
	1748.000	30.11	---	---	56.00	46.00	-15.89
	3510.000	32.89	---	---	56.00	46.00	-13.11
	5050.000	28.56	---	---	60.00	50.00	-21.44
	10780.000	41.23	---	---	60.00	50.00	-8.77
	12980.000	29.31	---	---	60.00	50.00	-20.69
Line 2	158.000	35.38	---	---	67.77	57.77	-22.39
	297.000	42.19	---	---	61.80	51.80	-9.61
	592.000	35.54	---	---	56.00	46.00	-10.46
	902.000	26.41	---	---	56.00	46.00	-19.59
	1464.000	27.76	---	---	56.00	46.00	-18.24
	2094.000	27.60	---	---	56.00	46.00	-18.40
	2610.000	27.58	---	---	56.00	46.00	-18.42
	3285.000	30.86	---	---	56.00	46.00	-15.14
	3819.000	28.63	---	---	56.00	46.00	-17.37
	6000.000	21.73	---	---	60.00	50.00	-28.27

Test Mode: (B) Mode for WLAN CH06

Power Connected Emissions					FCC Class B		
Conductor	Frequency (KHz)	Peak (dBμV)	QP (dBμV)	Average (dBμV)	QP-limit (dBμV)	AVG-limit (dBμV)	Margin (dB)
Line 1	153.000	28.63	---	---	65.91	55.91	-27.28
	172.000	27.90	---	---	63.37	53.37	-25.47
	297.000	38.37	---	---	61.80	51.80	-13.43
	587.000	34.00	---	---	56.00	46.00	-12.00
	1166.000	33.05	---	---	56.00	46.00	-12.95
	1766.000	28.70	---	---	56.00	46.00	-17.30
	3004.000	28.35	---	---	56.00	46.00	-17.65
	3221.000	32.11	---	---	56.00	46.00	-13.89
	3819.000	31.07	---	---	56.00	46.00	-14.93
Line 2	155.000	36.02	---	---	65.86	55.86	-19.84
	297.000	42.05	---	---	61.80	51.80	-9.75
	581.000	35.08	---	---	56.00	46.00	-10.92
	876.000	27.02	---	---	56.00	46.00	-18.98
	1166.000	28.84	---	---	56.00	46.00	-17.16
	1766.000	25.95	---	---	56.00	46.00	-20.05
	2072.000	28.77	---	---	56.00	46.00	-17.23
	2925.000	27.39	---	---	56.00	46.00	-18.61
	3542.000	30.54	---	---	56.00	46.00	-15.46
	20390.000	23.50	---	---	60.00	50.00	-26.50

Test Mode: (B) Mode for WLAN CH11

Power Connected Emissions					FCC Class B		
Conductor	Frequency (KHz)	Peak (dBμV)	QP (dBμV)	Average (dBμV)	QP-limit (dBμV)	AVG-limit (dBμV)	Margin (dB)
Line 1	297.000	37.87	---	---	61.80	51.80	-13.93
	592.000	33.85	---	---	56.00	46.00	-12.15
	893.000	32.89	---	---	56.00	46.00	-13.11
	1166.000	32.84	---	---	56.00	46.00	-13.16
	1490.000	28.84	---	---	56.00	46.00	-17.16
	1801.000	30.31	---	---	56.00	46.00	-15.69
	3221.000	31.92	---	---	56.00	46.00	-14.08
	3477.000	33.39	---	---	56.00	46.00	-12.61
	3780.000	31.92	---	---	56.00	46.00	-14.08
Line 2	158.000	35.40	---	---	65.77	55.77	-20.37
	291.000	41.86	---	---	61.97	51.97	-10.11
	598.000	30.38	---	---	56.00	46.00	-15.62
	876.000	27.14	---	---	56.00	46.00	-18.86
	1166.000	28.11	---	---	56.00	46.00	-17.89
	1490.000	27.67	---	---	56.00	46.00	-18.33
	2029.000	28.16	---	---	56.00	46.00	-17.84
	3221.000	28.18	---	---	56.00	46.00	-17.82
	3819.000	27.86	---	---	56.00	46.00	-18.14
	18750.000	22.52	---	---	60.00	50.00	-27.48

Test Mode: (B) Mode for WLAN + BT

Power Connected Emissions					FCC Class B		
Conductor	Frequency (KHz)	Peak (dBμV)	QP (dBμV)	Average (dBμV)	QP-limit (dBμV)	AVG-limit (dBμV)	Margin (dB)
Line 1	297.000	35.84	---	---	61.80	51.80	-15.96
	592.000	34.12	---	---	56.00	46.00	-11.88
	884.000	35.52	---	---	56.00	46.00	-10.48
	1208.000	34.62	---	---	56.00	46.00	-11.38
	1503.000	31.25	---	---	56.00	46.00	-14.75
	1801.000	31.28	---	---	56.00	46.00	-14.72
	3253.000	32.32	---	---	56.00	46.00	-13.68
	3542.000	34.19	---	---	56.00	46.00	-11.81
	3858.000	31.59	---	---	56.00	46.00	-14.41
	5910.000	28.02	---	---	60.00	50.00	-21.98
Line 2	164.000	35.26	---	---	65.60	55.60	-20.34
	206.000	30.15	---	---	64.40	54.40	-24.25
	291.000	43.12	---	---	61.97	51.97	-8.85
	598.000	36.30	---	---	56.00	46.00	-9.70
	884.000	28.24	---	---	56.00	46.00	-17.76
	1198.000	29.97	---	---	56.00	46.00	-16.03
	1766.000	29.26	---	---	56.00	46.00	-16.74
	2072.000	30.04	---	---	56.00	46.00	-15.96
	2663.000	28.66	---	---	56.00	46.00	-17.34
	3285.000	28.14	---	---	56.00	46.00	-17.86

V. Section 15.247 (a): Technical description of the EUT

Based on the Section 2.1, *Direct Sequence System* is a spread spectrum system in which the carrier has been modulated by a high speed spreading code and an information data stream. The high speed code sequence dominates the “modulating function” and is the direct cause of the wide spreading of the transmitted signal. In the operational description demonstrates the operation principles of the Baseband processor employed by the EUT, shows that which is a complete DSSS baseband processor and meets the definition of the Direct sequence spread spectrum system.

VI. Section 15.247(a)(2): Bandwidth for Direct Sequence System.

6.1 Test Condition & Setup

The transmitter bandwidth measurements were performed by the contact manner. The EUT was set to transmit continuously, also various channels were investigated to find the maximum occupied bandwidth. The output of the EUT was connected to the spectrum analyzer. The bandwidth of the fundamental frequency is observed by the spectrum analyzer with 100kHz RBW and 100kHz VBW.

6.2 Test Instruments Configuration

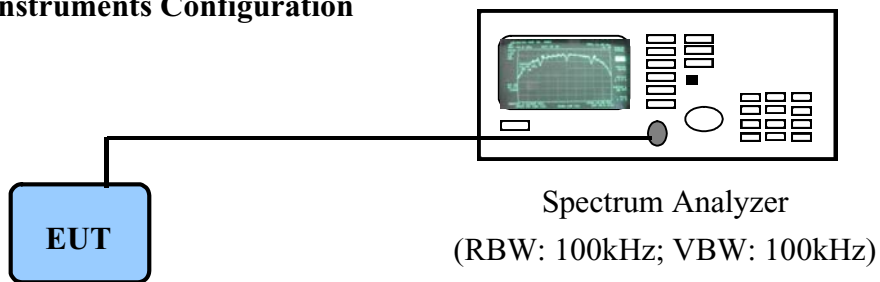

P.S.: The computer to control the EUT at maximal power output and channel Number and set antenna kit

6.3 List of Test Instruments

Instrument Name	Model No.	Brand	Serial No.	Last time	Next time
Spectrum Analyzer	MS2665C	ANRITSU	6200175476	09/30/03	09/30/04

6.4 Test Result of Bandwidth

Channel	Bandwidth
01	10.24 MHz
06	10.32 MHz
11	10.28 MHz

- Note:
- The data in the above table are summarizing the following attachment spectrum analyzer hard copy. According to the guidance, we'd made the measurement with the spectrum analyzer's resolution bandwidth (RBW)=100kHz and set the span>>RBW. The results show the measured 6dB bandwidth comply with the minimum 500kHz requirement.
 - The attachments show these on the following pages.

6dB Bandwidth of Channel 1: 10.24MHz (The minimum 6dB BW at least 500kHz)

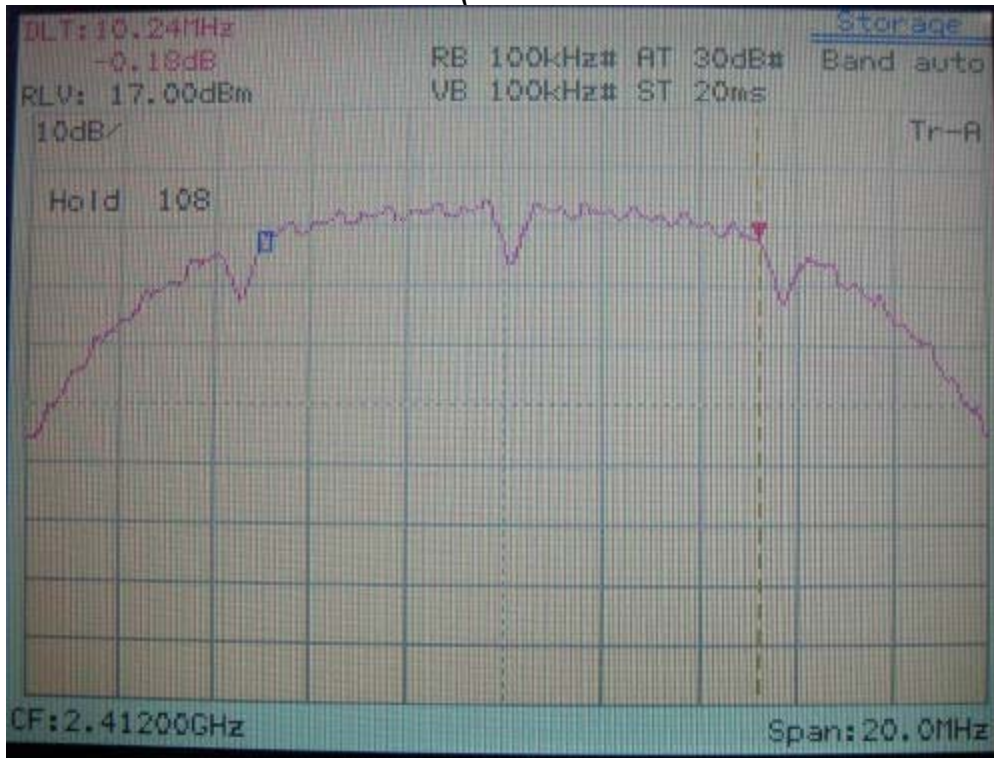

6dB Bandwidth of Channel 6: 10.326MHz (The minimum 6dB BW at least 500kHz)

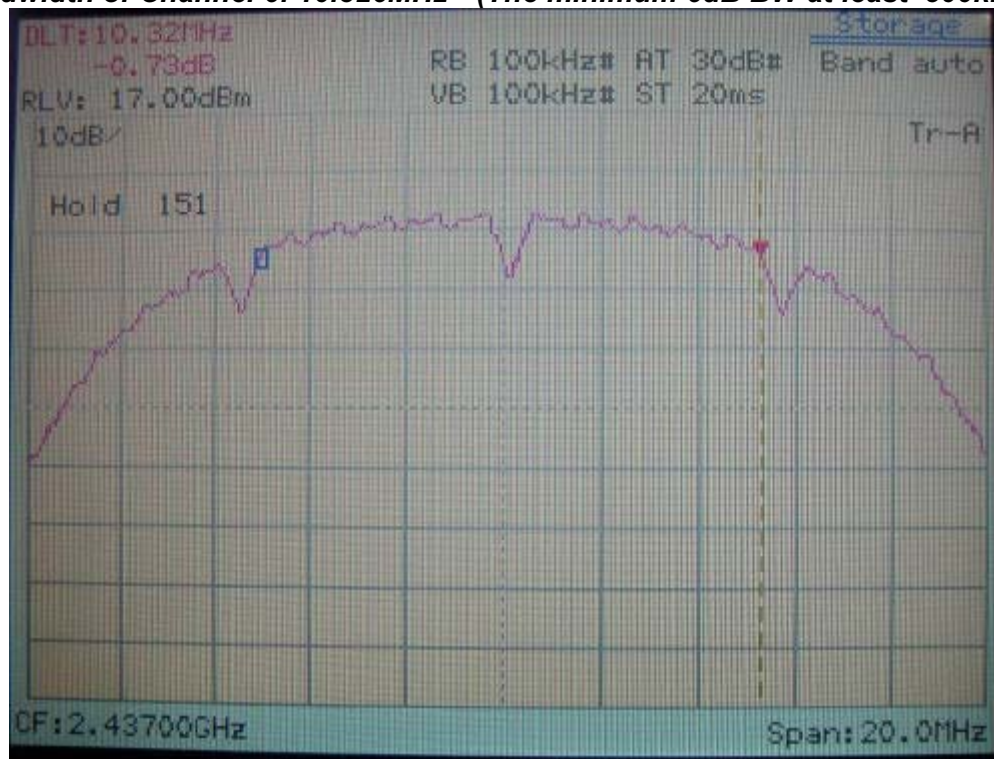

6dB Bandwidth of Channel 1: 10.28MHz (The minimum 6dB BW at least 500kHz)



VII. Section 15.247(b): Power Output

7.1 Test Condition & Setup



1. The output of the transmitter is connected to the BOONTON RF Power Meter.
2. The calibration is performed before every test. The values of the output power of the EUT will shown in the dBm directly are the transmitter output peak power. Recording as follows.

7.2 List of Test Instruments

Instrument Name	Model No.	Brand	Serial No.	Last time	Next time
RF Power Meter	4532	BOONTON	117501	04/16/04	04/16/05
Peak Power Sensor	57340	BOONTON	2698	04/16/04	04/16/05

7.3 Test Result

Formula:

$$\text{RF output power of EUT} + |\text{Cable loss}| = \text{Output peak power}$$

Channel	RF Output	Cable Loss	Output peak power	
	dBm		dBm	dBm
CH 1	14.59	1.00	15.59	38.90
CH 6	13.86	1.00	14.86	30.62
CH 11	13.04	1.00	14.04	25.35

VIII. Section 15.247 (C): Spurious Emissions (Radiated)

8.1 Test Condition & Setup

We'd performed the test by the *radiated emission* skill: The EUT was placed in an anechoic chamber, and set the EUT transmitting continuously and scanned at 3-meter distance to determine its emission characteristics. The physical arrangement of the EUT was varied (within the scope of arrangements likely to be encountered in actual use) to determine the effect on the unit's emanations in amplitude, directivity, and frequency. The exact system configuration, which produced the highest emissions was noted so it could be reproduced later during the final tests. For the measurement above 1GHz, according to the guidance we'd set the spectrum analyzer's 6dB bandwidth RBW to 1MHz.

This was done to ensure that the final measurements would demonstrate the worst-case interference potential of the EUT.

Final radiation measurements were made on a three-meter, anechoic chamber. The EUT system was placed on a nonconductive turntable, which is 0.8 meters height, top surface 1.0 x 1.5 meter.

The spectrum was examined from 30 MHz to 1000 MHz using an Hewlett Packard 85460A EMI Receiver, SCHWARZECK whole range Small Biconical Antenna (Model No.: UBAA9114 & BBVU9135) is used to measure frequency from 30 MHz to 1GHz. The final test is used the HP 85460A spectrum and 8564E spectrum was examined from 1GHz to 25GHz using an Hewlett Packard Spectrum Analyzer, EMCO/HP Horn Antenna (Model 3115 / 84125-80008) for 1G - 25GHz.

At each frequency, the EUT was rotated 360 degrees, stand on three orthogonal planes respectively and the antenna was raised and lowered from one to four meters to find the maximum emission levels. Measurements were taken using both horizontal and vertical antenna polarization.

Appropriate preamplifiers were used for improving sensitivity and precautions were taken to avoid overloading or desensitizing the spectrum analyzer. There are two spectrum analyzers use on this testing, HP 85460A for frequency 30MHz to 1000MHz, and 8564E for frequency 1GHz to 25GHz. No post-detector video filters were used in the test. The spectrum analyzer's 6dB bandwidth was set to 120KHz (spectrum was examined from 30 MHz to 1000 MHz), the spectrum analyzer's 6 dB bandwidth was set to 1 MHz (spectrum was examined from 1GHz to 25GHz) and the analyzer was operated in the maximum hold mode. There is a test condition applies in this test item, the test procedure description as the following:

Three channels were tested, one in the top (CH01), one in the middle (CH06) and the other in bottom (CH11). The setting up procedure is recorded on <1.3>

With the transmitter operating from a AC source and using the internal of EUT, radiates spurious emissions falling within the restricted bands of 15.209 were measured at operating frequencies corresponding to upper, middle and bottom channels in the 2400 ~ 2483.5 MHz band.

The actual field intensity in decibels referenced to 1 microvolt per meter (dB μ V/m) is determined by algebraically adding the measured reading in dB μ V, the antenna factor (dB), and cable loss (dB) at the appropriate frequency. Since the EUT was set to transmit continuously, no *duty cycle* is present.

For frequency between 30MHz to 1000MHz

$$F_{Ia} \text{ (dB}\mu\text{V/m)} = F_{Ir} \text{ (dB}\mu\text{V)} + \text{Correction Factors}$$

F_{Ia} : Actual Field Intensity

F_{Ir} : Reading of the Field Intensity

$$\text{Correction Factors} = \text{Antenna Factor} + \text{Cable Loss} - \text{Amplifier Gain}$$

For frequency between 1GHz to 25GHz

$$F_{Ia} \text{ (dB}\mu\text{V/m)} = F_{Ir} \text{ (dB}\mu\text{V)} + \text{Correction Factor}$$

F_{Ia} : Actual Field Intensity

F_{Ir} : Reading of the Field Intensity

$$\text{Correction Factors} = \text{Antenna Factor} + \text{Cable Loss} - \text{Amplifier Gain}$$

8.2 List of Test Instruments

				Calibration Date
Instrument Name	Model	Brand	Serial No.	Next time
EMI Receiver	8546A	HP	3520A00242	07/28/04
RF Filter Section	85460A	HP	3448A00217	07/28/04
Small Biconical Antenna	UBAA9114 & BBVU9135	SCHWARZECK	127	09/21/04
Pre-amplifier	PA1F	TRC	1FAC	05/20/05
Auto Switch Box (>30MHz)	ASB-01	TRC	9904-01	05/20/05
Coaxial Cable (Double shielded, 15 meter)	A30A30-0058-50FS-15M	JYEBAO	SMA-01	05/20/05
Coaxial Cable (1.1 meter)	A30A30-0058-50FS-1M	JYEBAO	SMA-02	05/20/05
Spectrum Analyzer	8564E	HP	3720A00840	07/23/04
Microwave Preamplifier	84125C	HP	US36433002	07/30/04
Horn Antenna	3115	EMCO	9104-3668	12/18/04
Standard Guide Horn Antenna	84125-80008	HP	18-26.5GHz	09/18/04
Standard Guide Horn Antenna	84125-80001	HP	26.5-40GHz	09/18/04
Pre-amplifier	84125C	HP	US36433002	11/19/04
Horn Antenna	1196E (3115)	HP (EMCO)	9704-5178	12/12/04
Pre-amplifier	PA2F	TRC	2F1GZ	03/20/05
Coaxial Cable (3 miter)	A30A30-0058-50FS T118	JYEBAO	MSA-05	03/20/05
Coaxial Cable (1 meter)	A30A30-0058-50FS T118	JYEBAO	MSA-04	03/20/05

8.3 Test Result of Spurious Radiated Emissions

The highest peak values of radiated emissions from the EUT at various antenna heights, antenna polarizations, EUT orientation, etc. are recorded on the following. (worst case)

Test Conditions: Temperature : 25 ° C Humidity : 73 % RH

Test mode: RX mode for 30MHz to 25GHz [Horizontal]

Radiated Emission				Correction Factors (dB)	Corrected Amplitude (dBµV/m)	Class B (3 m)	
Frequency (MHz)	Amplitude (dBµV)	Ant. H. (m)	Table (°)			Limit (dBµV/m)	Margin (dB)
207.02	44.14	1.00	219	-3.87	40.27	43.50	-3.23
314.94	47.42	1.00	248	-3.42	44.00	46.00	-2.00
376.77	40.86	1.00	222	-1.80	39.06	46.00	-6.94
495.60	36.36	1.00	199	2.73	39.09	46.00	-6.91
11476.25	28.41	1.00	297	21.76	50.17	53.96	-3.79
13813.75	32.74	1.00	29	19.34	52.08	53.96	-1.88

Test mode: RX mode for 30MHz to 25GHz [Vertical]

Radiated Emission				Correction Factors (dB)	Corrected Amplitude (dBµV/m)	Class B (3 m)	
Frequency (MHz)	Amplitude (dBµV)	Ant. H. (m)	Table (°)			Limit (dBµV/m)	Margin (dB)
32.42	28.30	1.00	226	7.24	35.54	43.50	-7.96
154.89	37.85	1.00	46	-3.30	34.55	43.50	-8.95
205.81	39.66	1.00	64	-3.86	35.80	43.50	-7.70
210.66	40.99	1.00	64	-3.90	37.09	43.50	-6.41
728.40	32.00	1.00	302	10.05	42.05	46.00	-3.95
13771.25	30.74	1.00	310	19.63	50.37	53.96	-3.59

Note:

1. Margin = Amplitude – limit, *if margin is minus means under limit.*
2. Corrected Amplitude = Reading Amplitude + Correction Factors
3. Correction factor = Antenna factor + (Cable Loss – Amplitude gain) + Switching Box Loss

Test mode: WLAN+BT mode for 30MHz to 25GHz, EUT X-axis [Horizontal]

<i>Radiated Emission</i>				<i>Correction Factors</i>	<i>Corrected Amplitude</i>	<i>Class B (3 m)</i>	
<i>Frequency (MHz)</i>	<i>Amplitude (dBμV)</i>	<i>Ant. H. (m)</i>	<i>Table (°)</i>			<i>Limit (dBμV/m)</i>	<i>Margin (dB)</i>
191.26	37.44	1.00	207	-3.68	33.76	43.50	-9.74
210.66	45.15	1.00	207	-3.90	41.25	43.50	-2.25
339.19	41.13	1.00	256	-2.94	38.19	46.00	-7.81
386.47	43.77	1.00	84	-1.47	42.30	46.00	-3.70
410.72	36.22	1.00	84	-0.57	35.65	46.00	-10.35
847.22	21.59	1.00	270	13.10	34.69	46.00	-11.31

Test mode: WLAN+BT mode for 30MHz to 25GHz, EUT Z-axis [Vertical]

<i>Radiated Emission</i>				<i>Correction Factors</i>	<i>Corrected Amplitude</i>	<i>Class B (3 m)</i>	
<i>Frequency (MHz)</i>	<i>Amplitude (dBμV)</i>	<i>Ant. H. (m)</i>	<i>Table (°)</i>			<i>Limit (dBμV/m)</i>	<i>Margin (dB)</i>
159.74	39.12	1.00	290	-3.46	35.66	43.50	-7.84
205.81	35.42	1.00	328	-3.86	31.56	43.50	-11.94
216.72	38.03	1.00	6	-3.94	34.09	46.00	-11.91
673.84	26.69	1.00	48	8.99	35.68	46.00	-10.32
722.34	24.07	1.00	357	9.95	34.02	46.00	-11.98
772.05	23.74	1.00	39	10.94	34.68	46.00	-11.32

Test mode: WLAN CH01 for 30MHz to 1GHz, EUT Z-axis [Horizontal]

<i>Radiated Emission</i>				<i>Correction Factors (dB)</i>	<i>Corrected Amplitude (dBμV/m)</i>	<i>Class B (3 m)</i>	
<i>Frequency (MHz)</i>	<i>Amplitude (dBμV)</i>	<i>Ant. H. (m)</i>	<i>Table (°)</i>			<i>Limit (dBμV/m)</i>	<i>Margin (dB)</i>
128.21	34.22	1.00	263	-2.55	31.67	43.50	-11.83
180.35	36.87	1.00	255	-3.76	33.11	43.50	-10.39
204.60	44.34	1.00	281	-3.85	40.49	43.50	-3.01
294.32	37.75	1.00	299	-3.74	34.01	46.00	-11.99
413.15	36.41	1.00	155	-0.47	35.94	46.00	-10.06
838.74	25.03	1.00	18	12.83	37.86	46.00	-8.14

Test mode: WLAN CH01 for 30MHz to 1GHz, EUT X-axis [Vertical]

<i>Radiated Emission</i>				<i>Correction Factors (dB)</i>	<i>Corrected Amplitude (dBμV/m)</i>	<i>Class B (3 m)</i>	
<i>Frequency (MHz)</i>	<i>Amplitude (dBμV)</i>	<i>Ant. H. (m)</i>	<i>Table (°)</i>			<i>Limit (dBμV/m)</i>	<i>Margin (dB)</i>
173.07	40.44	1.00	208	-3.78	36.66	43.50	-6.84
180.35	41.75	1.00	228	-3.76	37.99	43.50	-5.51
188.84	39.86	1.00	38	-3.67	36.19	43.50	-7.31
205.81	37.02	1.00	184	-3.86	33.16	43.50	-10.34
551.37	27.42	1.00	241	5.06	32.48	46.00	-13.52
673.84	25.12	1.00	137	8.99	34.11	46.00	-11.89

Test mode: WLAN CH01 for 1GHz to 25GHz, EUT X-axis [Horizontal]

Frequency	Ant. H.	Table	Amplitude		Correction Factor	Corrected Amplitude		Limit		Margin
			Peak / Ave.			Peak / Ave.		Peak / Ave.		
MHz	m	degree	dBµV		dB/m	dBµV/m		dBµV/m		dB
2547.92	1.00	12	36.33	---	9.58	45.91	---	73.96	53.96	-8.05
7233.75	1.00	180	35.44	---	10.07	45.51	---	73.96	53.96	-8.45
9644.37	1.00	190	35.61	---	11.44	47.05	---	73.96	53.96	-6.91
12055.00	1.00	0	37.77	---	9.83	47.60	---	73.96	53.96	-6.36
19296.25	1.00	79	47.83	---	1.22	49.05	---	73.96	53.96	-4.91

Test mode: WLAN CH01 for 1GHz to 25GHz, EUT Z-axis [Vertical]

Frequency	Ant. H.	Table	Amplitude		Correction Factor	Corrected Amplitude		Limit		Margin
			Peak / Ave.			Peak / Ave.		Peak / Ave.		
MHz	m	degree	dBµV		dB/m	dBµV/m		dBµV/m		dB
4823.12	1.00	207	40.27	---	3.76	44.03	---	73.96	53.96	-9.93
7233.75	1.00	48	35.44	---	10.07	45.51	---	73.96	53.96	-8.45
9644.37	1.00	238	35.44	---	11.44	46.88	---	73.96	53.96	-7.08
12055.00	1.00	303	37.27	---	9.83	47.10	---	73.96	53.96	-6.86
19296.25	1.00	98	46.00	---	1.22	47.22	---	73.96	53.96	-6.74

Note:

1. Margin = Corrected - Limit.
2. The EUT utilizes a *permanently attached antenna*. In addition the spurious RF radiated emissions levels do comply with the *20dBc limit* both at its bandedges and other spurious emissions.
3. As stated in Section 15.35(b), for any frequencies above 1000MHz, radiated limits shown are based upon the use of measurement instrumentation employing an average detector function. As the results of our test, the peak amplitudes are already below the FCC limit. Thus the average amplitudes of the rest are omitted.

Test mode: WLAN CH06 for 30MHz to 1GHz, EUT Z-axis [Horizontal]

<i>Radiated Emission</i>				<i>Correction Factors</i>	<i>Corrected Amplitude</i>	<i>Class B (3 m)</i>	
<i>Frequency (MHz)</i>	<i>Amplitude (dBµV)</i>	<i>Ant. H. (m)</i>	<i>Table (°)</i>			<i>Limit (dBµV/m)</i>	<i>Margin (dB)</i>
86.99	29.48	1.00	165	-0.25	29.23	40.00	-10.77
170.65	36.27	1.00	259	-3.79	32.48	43.50	-11.02
187.62	40.33	1.00	259	-3.68	36.65	43.50	-6.85
204.60	44.68	1.00	116	-3.85	40.83	43.50	-2.67
210.66	45.36	1.00	139	-3.90	41.46	43.50	-2.04
310.09	40.85	1.00	259	-3.51	37.34	46.00	-8.66

Test mode: WLAN CH06 for 30MHz to 1GHz, EUT Z-axis [Vertical]

<i>Radiated Emission</i>				<i>Correction Factors</i>	<i>Corrected Amplitude</i>	<i>Class B (3 m)</i>	
<i>Frequency (MHz)</i>	<i>Amplitude (dBµV)</i>	<i>Ant. H. (m)</i>	<i>Table (°)</i>			<i>Limit (dBµV/m)</i>	<i>Margin (dB)</i>
204.60	33.85	1.00	227	-3.85	30.00	43.50	-13.50
288.26	36.06	1.00	155	-3.80	32.26	46.00	-13.74
413.15	27.93	1.00	307	-0.47	27.46	46.00	-18.54
519.85	25.71	1.00	203	3.74	29.45	46.00	-16.55
612.00	28.14	1.00	20	7.10	35.24	46.00	-10.76
661.71	27.84	1.00	348	8.72	36.56	46.00	-9.44

Test mode: WLAN CH06 for 1GHz to 25GHz, EUT X-axis [Horizontal]

<i>Frequency</i>	<i>Ant. H.</i>	<i>Table</i>	<i>Amplitude</i>		<i>Correction Factor</i>	<i>Corrected Amplitude</i>		<i>Limit</i>		<i>Margin</i>
			<i>Peak / Ave.</i>			<i>Peak / Ave.</i>		<i>Peak / Ave.</i>		
<i>MHz</i>	<i>m</i>	<i>degree</i>	<i>dBμV</i>		<i>dB/m</i>	<i>dBμV/m</i>		<i>dBμV/m</i>		<i>dB</i>
2925.00	1.00	169	36.33	---	10.29	46.62	---	73.96	53.96	-7.34
7306.25	1.00	360	35.94	---	10.29	46.23	---	73.96	53.96	-7.73
9747.08	1.00	312	35.60	---	11.89	47.49	---	73.96	53.96	-6.47
12181.87	1.00	273	38.10	---	9.72	47.82	---	73.96	53.96	-6.14
19494.58	1.00	173	46.17	---	1.19	47.36	---	73.96	53.96	-6.60

Test mode: WLAN CH06 for 1GHz to 25GHz, EUT Z-axis [Vertical]

<i>Frequency</i>	<i>Ant. H.</i>	<i>Table</i>	<i>Amplitude</i>		<i>Correction Factor</i>	<i>Corrected Amplitude</i>		<i>Limit</i>		<i>Margin</i>
			<i>Peak / Ave.</i>			<i>Peak / Ave.</i>		<i>Peak / Ave.</i>		
<i>MHz</i>	<i>m</i>	<i>degree</i>	<i>dBμV</i>		<i>dB/m</i>	<i>dBμV/m</i>		<i>dBμV/m</i>		<i>dB</i>
7306.25	1.00	116	35.27	---	10.29	45.56	---	73.96	53.96	-8.40
9747.08	1.00	63	35.27	---	11.89	47.16	---	73.96	53.96	-6.80
12181.87	1.00	28	38.77	---	9.72	48.49	---	73.96	53.96	-5.47
21931.25	1.00	93	45.67	---	0.84	46.51	---	73.96	53.96	-7.45
24367.92	1.00	0	45.50	---	0.50	46.00	---	73.96	53.96	-7.96

Test mode: WLAN CH11 for 30MHz to 1GHz, EUT Y-axis [Horizontal]

<i>Radiated Emission</i>				<i>Correction Factors</i>	<i>Corrected Amplitude</i>	<i>Class B (3 m)</i>	
<i>Frequency (MHz)</i>	<i>Amplitude (dBμV)</i>	<i>Ant. H. (m)</i>	<i>Table (°)</i>			<i>Limit (dBμV/m)</i>	<i>Margin (dB)</i>
91.84	29.92	1.00	89	-0.57	29.35	43.50	-14.15
127.00	37.62	1.00	223	-2.49	35.13	43.50	-8.37
204.60	41.16	1.00	252	-3.85	37.31	43.50	-6.19
374.35	33.75	1.00	119	-1.89	31.86	46.00	-14.14
710.21	23.93	1.00	356	9.75	33.68	46.00	-12.32
759.92	23.95	1.00	4	10.65	34.60	46.00	-11.40

Test mode: WLAN CH11 for 30MHz to 1GHz, EUT Y-axis [Vertical]

<i>Radiated Emission</i>				<i>Correction Factors</i>	<i>Corrected Amplitude</i>	<i>Class B (3 m)</i>	
<i>Frequency (MHz)</i>	<i>Amplitude (dBμV)</i>	<i>Ant. H. (m)</i>	<i>Table (°)</i>			<i>Limit (dBμV/m)</i>	<i>Margin (dB)</i>
288.26	35.61	1.00	171	-3.80	31.81	46.00	-14.19
456.80	27.03	1.00	319	1.27	28.30	46.00	-17.70
511.36	27.74	1.00	330	3.38	31.12	46.00	-14.88
551.37	26.65	1.00	356	5.06	31.71	46.00	-14.29
624.12	25.97	1.00	56	7.53	33.50	46.00	-12.50
673.84	25.50	1.00	334	8.99	34.49	46.00	-11.51

Test mode: WLAN CH11 for 1GHz to 25GHz, EUT X-axis [Horizontal]

<i>Frequency</i>	<i>Ant. H.</i>	<i>Table</i>	<i>Amplitude</i>		<i>Correction Factor</i>	<i>Corrected Amplitude</i>		<i>Limit</i>		<i>Margin</i>
			<i>Peak / Ave.</i>			<i>Peak / Ave.</i>		<i>Peak / Ave.</i>		
<i>MHz</i>	<i>m</i>	<i>degree</i>	<i>dBμV</i>		<i>dB/m</i>	<i>dBμV/m</i>		<i>dBμV/m</i>		<i>dB</i>
7384.79	1.00	113	37.11	---	10.42	47.53	---	73.96	53.96	-6.43
9849.79	1.00	163	35.28	---	11.93	47.21	---	73.96	53.96	-6.75
12308.75	1.00	57	36.77	---	9.56	46.33	---	73.96	53.96	-7.63
19696.46	1.00	124	46.17	---	1.16	47.33	---	73.96	53.96	-6.63
24619.37	1.00	8	45.50	---	0.47	45.97	---	73.96	53.96	-7.99

Test mode: WLAN CH11 for 1GHz to 25GHz, EUT Y-axis [Vertical]

<i>Frequency</i>	<i>Ant. H.</i>	<i>Table</i>	<i>Amplitude</i>		<i>Correction Factor</i>	<i>Corrected Amplitude</i>		<i>Limit</i>		<i>Margin</i>
			<i>Peak / Ave.</i>			<i>Peak / Ave.</i>		<i>Peak / Ave.</i>		
<i>MHz</i>	<i>m</i>	<i>degree</i>	<i>dBμV</i>		<i>dB/m</i>	<i>dBμV/m</i>		<i>dBμV/m</i>		<i>dB</i>
7384.79	1.00	54	36.61	---	10.42	47.03	---	73.96	53.96	-6.93
9849.79	1.00	153	35.61	---	11.93	47.54	---	73.96	53.96	-6.42
12308.75	1.00	109	36.94	---	9.56	46.50	---	73.96	53.96	-7.46
19696.46	1.00	320	46.67	---	1.16	47.83	---	73.96	53.96	-6.13
24619.37	1.00	122	46.00	---	0.47	46.47	---	73.96	53.96	-7.49

8.4 Test Result of the Bandedge

If any 100 kHz bandwidth outside these frequency bands, the radio frequency power that is produced by the modulation products of the spreading sequence, the information sequence and the carrier frequency shall be either *at least 20 dB below that in any 100 kHz bandwidth within the band that contains the highest level of the desired power or shall not exceed the general levels specified in § 15.209(a)*,

We perform this section by the *radiated manner*, the RBW is set to 100kHz and VBW>RBW. We'd made the observation *up to 10th harmonics and the criterion is all the harmonic/spurious emissions must be 20dB below the highest emission level measured*. If the emissions fall in the restricted bands stated in the Part15.205(a) must also *comply with the radiated emission limits specified in Part15.209(a)*. (*Peak mode: RBW=VBW=1MHz, Average mode: RBW=1MHz; VBW=10Hz*)

The following pages show our observations referring to the channel 1 and 11 respectively.

Test Condition & Setup: same as < 8.1 >

Channel 1

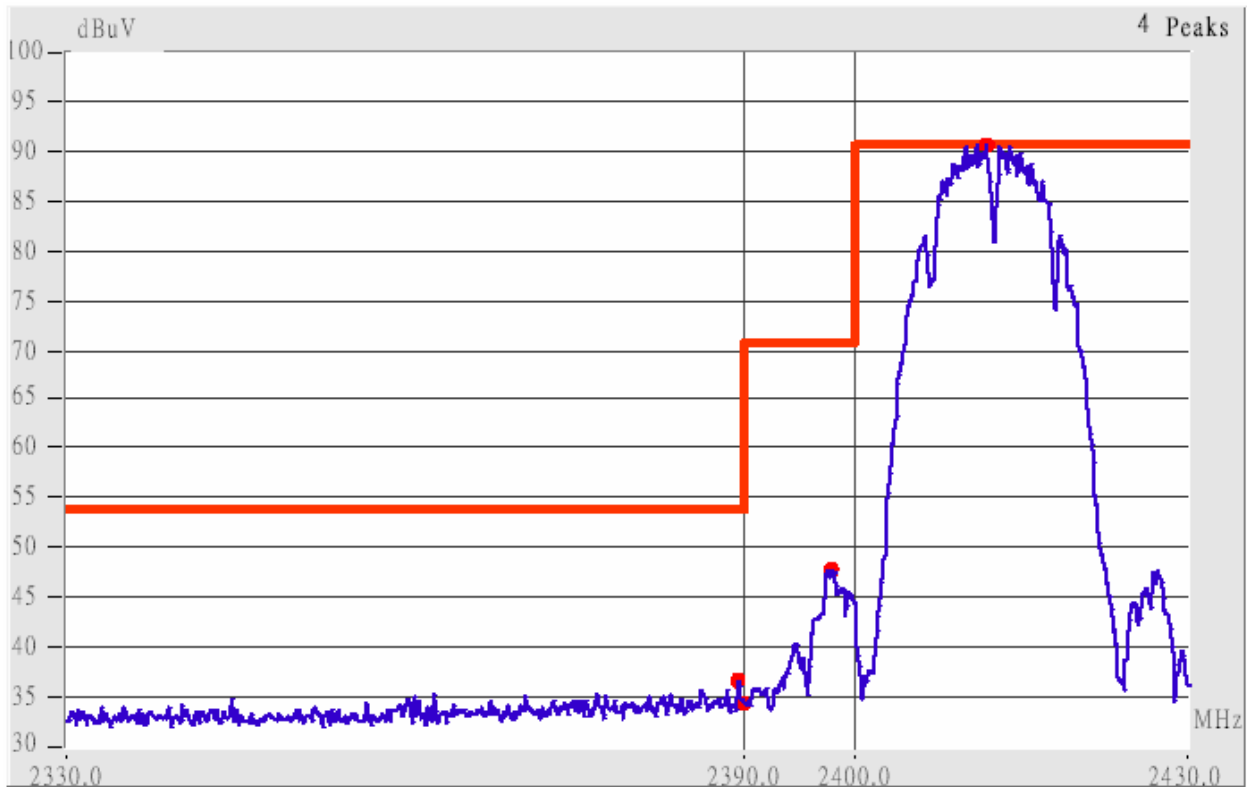

This is the hard copy of our bandedge measurement generated by our bandedge testing program. The plot shown above is the bandedge of channel 1.

1. The lobe left by the fundamental side is already 20dB below the highest emission level.
2. The emissions recorded in the restricted band is do comply with the Part 15.209(a) – as below.

<i>Radiated Emission</i>					<i>Corrected Amplitude</i>		<i>Class B (3m)</i>		
<i>Frequency (MHz)</i>	<i>Ant. P.</i>	<i>Ant. H. (m)</i>	<i>Table (°)</i>	<i>Factors (dB)</i>	<i>(dBµV/m)</i>		<i>Limit (dBµV/m)</i>		<i>Margin (dB)</i>
					<i>Peak</i>	<i>Average</i>	<i>Peak</i>	<i>Ave.</i>	
2385.74	Hor	1.00	64	9.17	47.34	---	74.00	53.96	-6.62
2390.02	Hor	1.00	65	9.18	45.85	---	74.00	53.96	-8.11
2386.55	Ver	1.00	135	9.17	46.51	---	74.00	53.96	-7.45
2390.02	Ver	1.00	21	9.18	45.02	---	74.00	53.96	-8.94

Channel 11

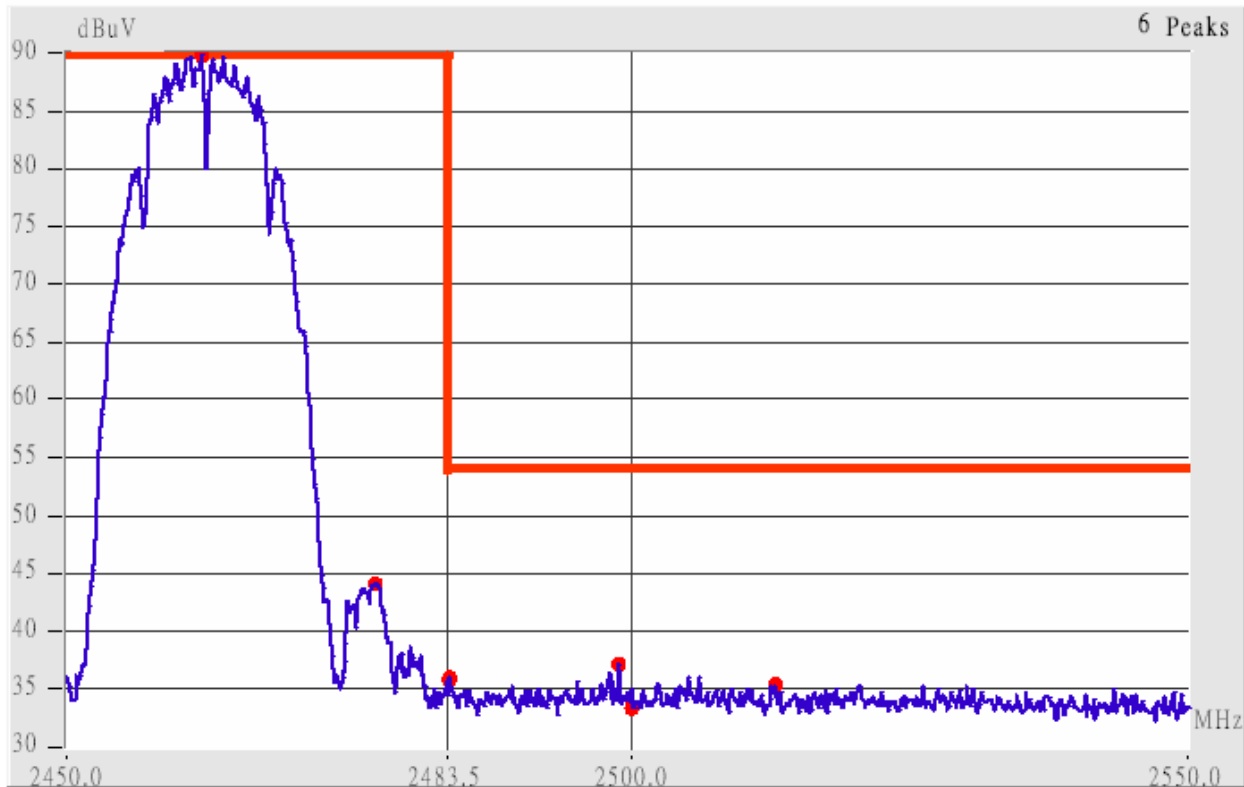

This is the hard copy of our bandedge measurement generated by our bandedge testing program. The plot shown above is the bandedge of channel 11.

1. The lobe right by the fundamental side is already 20dB below the highest emission level.
2. The emissions recorded in the restricted band is do comply with the Part 15.209(a) – as below

Radiated Emission					Corrected Amplitude		Class B (3m)		
Frequency (MHz)	Ant. P.	Ant. H. (m)	Table (°)	Factors (dB)	(dBµV/m)		Limit (dBµV/m)		Margin (dB)
					Peak	Average	Peak	Ave.	
2483.50	Hor	1.00	304	9.44	45.94	---	74.00	53.96	-8.02
2494.64	Hor	1.00	95	9.47	48.31	---	74.00	53.96	-5.65
2500.01	Hor	1.00	108	9.49	44.32	---	74.00	53.96	-9.64
2519.96	Hor	1.00	3	9.53	47.36	---	74.00	53.96	-6.60
2488.11	Ver	1.00	274	9.46	45.12	---	74.00	53.96	-8.84
2506.13	Ver	1.00	103	9.51	44.83	---	74.00	53.96	-9.13

IX. Section 15.247(d): Power Spectral Density

9.1 Test Condition & Setup

The tests below are running with the EUT transmitter set at high power in TDD mode. The EUT is needed to force selection of output power level and channel number. While testing, the EUT was set to transmit continuously and to be tested by the contact manner with the spectrum analyzer.

9.2 Test Instruments Configuration

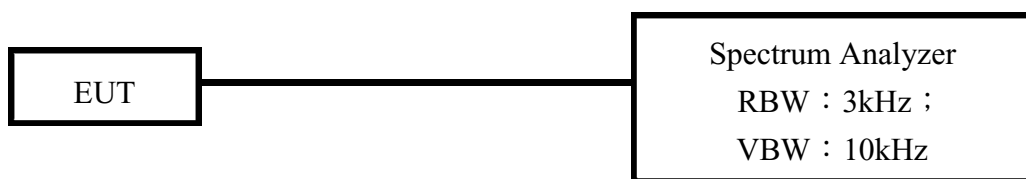

9.3 List of Test Instruments

Instrument Name	Model No.	Brand	Serial No.	Last time	Next time
Spectrum Analyzer	MS2665C	ANRITSU	6200175476	09/30/03	09/30/04

9.4 Test Result of Power spectral density

The following table shows a summary of the test results of the Power Spectral Density.

Channel	Ppr (dBm)	Cable Loss (dB)	Ppq (dBm)	Limit (dB)	Margin (dB)
CH 01	-18.14	1.00	-17.14	8.00	-25.14
CH 06	-18.74	1.00	-17.74	8.00	-25.74
CH 11	-19.22	1.00	-18.22	8.00	-26.22

Note:

1. The following pages show the results of spectrum reading.
2. Ppr: spectrum read power density (using peak search mode),
Ppq: actual peak power density in the spread spectrum band.
3. $Ppq = Ppr + |Cable Loss|$

Channel 01 of Power Spectral Density

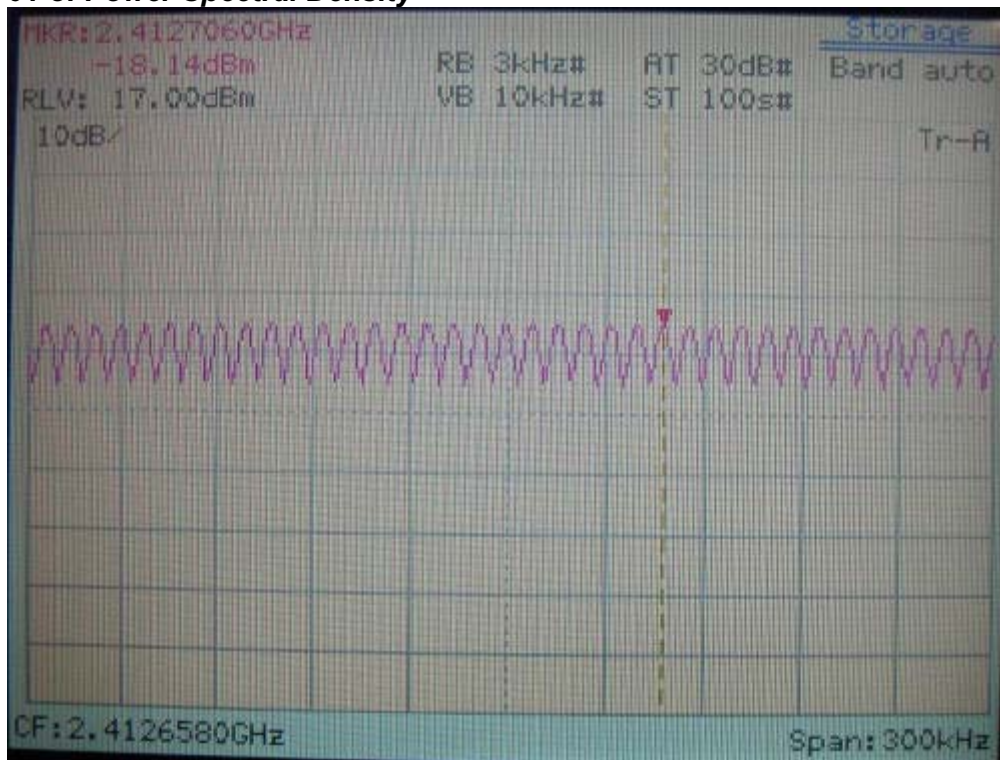

Channel 06 of Power Spectral Density

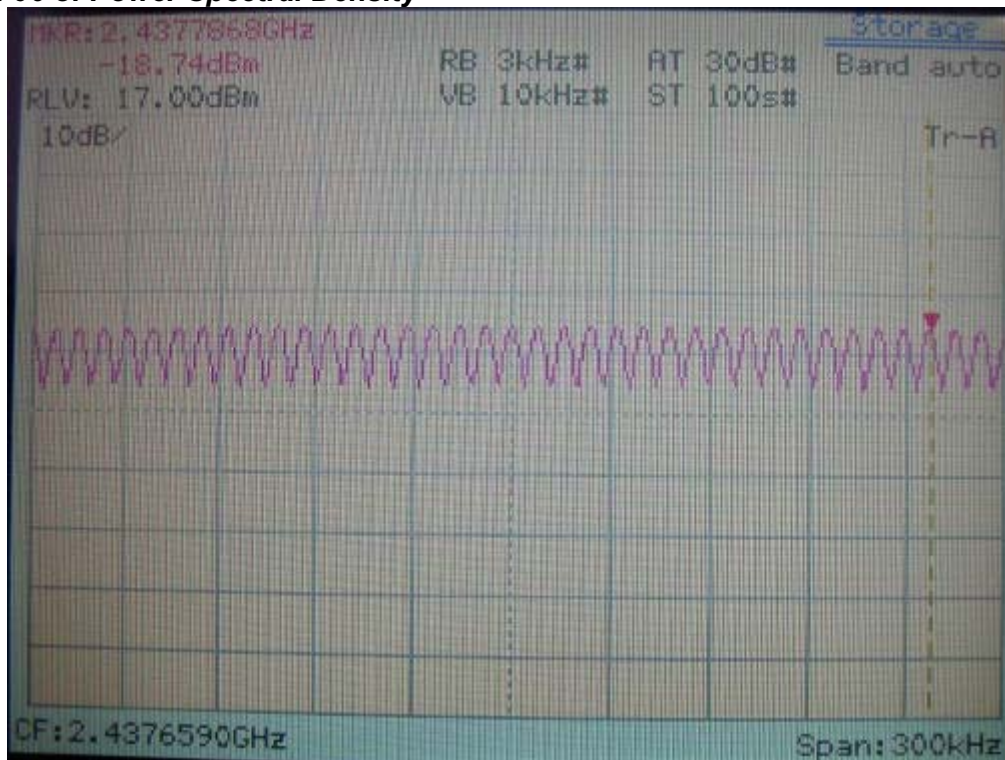

Channel 11 of Power Spectral Density

