



A Test Lab Techno Corp.

Changan Lab : No. 140-1, Changan Street, Bade District, Taoyuan City 33465, Taiwan (R.O.C.).

Tel : 886-3-271-0188 / Fax : 886-3-271-0190



SAR EVALUATION REPORT

Applicant	: ASUSTeK COMPUTER INC.
Applicant Address	: 4F, No. 150, Li-Te Rd., Peitou, Taipei, Taiwan
Product Type	: Intel Wireless-AC 9560
Trade Name	: Intel
Model Number	: 9560NGW
Received Date	: Mar. 18, 2019
Test Period	: Apr. 04 ~ Apr. 05, 2019
Issue Date	: May 08, 2019
Test Environment	: Ambient Temperature : $22 \pm 2 \text{ }^\circ\text{C}$ Relative Humidity : 40 - 70 %
Standard	: ANSI/IEEE C95.1-1992 / IEEE Std. 1528-2013 47 CFR Part §2.1093 KDB 865664 D01 v01r04 / KDB 865664 D02 v01r02 KDB 447498 D01 v06 / KDB 248227 D01 v02r02 KDB 616217 D04 v01r02
Test Firm MRA designation number	: TW0010



1. A Test Lab Techno Corp. tested the above equipment in accordance with the requirements set forth in the above standards. All indications of Pass/Fail in this report are opinions expressed by A Test Lab Techno Corp. based on interpretations and/or observations of test results. The test results show that the equipment tested is capable of demonstrating compliance with the requirements as documented in this report.
2. This report shall not be reproduced except in full, without the written approval of A Test Lab Techno Corp. This document may be altered or revised by A Test Lab Techno Corp. personnel only, and shall be noted in the revision section of the document. The client should not use it to claim product endorsement by TAF, or any government agencies. The test results in the report only apply to the tested sample.

Approved By : Edison Hu
(Edison Hu)

Tested By : Kris Pan
(Kris Pan)



Revision History

Rev.	Issue Date	Revisions	Revised By
00	May 02, 2019	Initial Issue	Shelly Chen
01	May 08, 2019	Page 18 Revised Conducted Power.	Shelly Chen



Contents

1. Summary of Maximum Reported SAR Value	4
2. Description of Equipment under Test (EUT)	5
3. Introduction.....	8
3.1 SAR Definition	8
4. SAR Measurement Setup	9
4.1 DASY E-Field Probe System.....	10
4.1.1 E-Field Probe Specification	10
4.2 Data Acquisition Electronic (DAE) System.....	11
4.3 Robot.....	11
4.4 Measurement Server.....	11
4.5 Device Holder.....	12
4.6 Oval Flat Phantom - ELI 5.0.....	12
5. Tissue Simulating Liquids.....	13
5.1 The composition of the tissue simulating liquid.....	14
5.2 Liquid Parameters	15
5.3 Liquid Depth	16
6. SAR Testing with RF Transmitters	17
6.1 WLAN RF Conducted Power.....	17
6.2 Conducted Power.....	18
6.3 Antenna location.....	22
6.4 Standalone SAR Test Exclusion Calculation	23
6.5 Simultaneous Transmitting Evaluate	23
6.5.1 Sum of 1-g SAR of all simultaneously transmitting	23
6.5.2 SAR to peak location separation ratio (SPLSR).....	24
7. System Verification and Validation	25
7.1 Symmetric Dipoles for System Verification	25
7.2 Verification Summary	26
8. Test Equipment List.....	27
9. Measurement Uncertainty	28
10. Measurement Procedure.....	30
10.1 Spatial Peak SAR Evaluation	30
10.2 Area & Zoom Scan Procedures	31
10.3 Volume Scan Procedures.....	31
10.4 Power Drift Monitoring.....	31
11. SAR Test Results Summary	32
11.1 Body SAR Measurement.....	32
11.2 SAR Variability Measurement.....	33
11.3 SAR Exposure Limit	34
12. References.....	35
Appendix A - System Performance Check.....	36
Appendix B - SAR Measurement Data.....	40
Appendix C - Calibration.....	59



1. Summary of Maximum Reported SAR Value

Equipment Class	Mode	Highest Reported
		Body standalone SAR _{1g} (W/kg)
DTS	WLAN 2.4 GHz ANT-Main	1.10
	WLAN 2.4 GHz ANT-AUX	0.42
U-NII	WLAN 5 GHz ANT-Main	1.00
	WLAN 5 GHz ANT-AUX	1.11
DSS	Bluetooth ANT-AUX	0.18
Highest Simultaneous Transmission SAR		Body standalone SAR _{1g} (W/kg)
At test position Bottom of laptop		2.29

Note: The SAR limit (Head & Body: SAR_{1g} 1.6 W/kg) for general population / uncontrolled exposure is specified in FCC 47 CFR part 2 (2.1093) and ANSI/IEEE C95.1-1992.



2. Description of Equipment under Test (EUT)

Applicant	ASUSTeK COMPUTER INC. 4F, No. 150, Li-Te Rd., Peitou, Taipei, Taiwan	
Manufacturer	ASUSTeK COMPUTER INC. 4F, No. 150, Li-Te Rd., Peitou, Taipei, Taiwan	
Product Type	Intel Wireless-AC 9560	
Trade Name	Intel	
Model Number	9560NGW	
FCC ID	MSQ9560NG	
Class II Permissive Change	<p>(1) This is to request a Class II permissive change for FCC ID: MSQ9560NG, originally granted on 11/20/2017</p> <p>The major change filed under this application is:</p> <p>Change #1: Additional Chassis added, ASUSTeK, model number: S432F, V432F, K432F. Models difference: All models are electrically identical, different model names are for marketing purpose.</p> <p>#2: Reduce the Output Power through firmware and SAR measurement were evaluated. (Only reduce Wi-Fi Output Power, Bluetooth Output Power haven't changes).</p> <p>#3: Addition one antenna, the antenna type is same, the antenna gain is lower than the original application.</p>	
Host Information	<p>Product Type: Notebook PC</p> <p>Trade Name: ASUS</p> <p>Model Name: S432F, V432F, K432F</p> <p>(All models are electrically identical, different model names are for marketing purpose.)</p>	
Frequency Range	Operate Modes	Operate Frequency (MHz)
	IEEE 802.11b / 802.11g / 802.11n 2.4 GHz 20 MHz	2412 - 2472
	IEEE 802.11n 2.4 GHz 40 MHz	2422 - 2462
	IEEE 802.11a U-NII Band I	5180 - 5240
	IEEE 802.11a U-NII Band II-A	5260 - 5320
	IEEE 802.11a U-NII Band II-C	5500 - 5700
	IEEE 802.11a U-NII Band III	5745 - 5825
	IEEE 802.11n 5 GHz 20 MHz U-NII Band I	5180 - 5240
	IEEE 802.11n 5 GHz 20 MHz U-NII Band II-A	5260 - 5320
	IEEE 802.11n 5 GHz 20 MHz U-NII Band II-C	5500 - 5700
	IEEE 802.11n 5 GHz 20 MHz U-NII Band III	5745 - 5825
	IEEE 802.11n 5 GHz 40 MHz U-NII Band I	5190 - 5230
	IEEE 802.11n 5 GHz 40 MHz U-NII Band II-A	5270 - 5310
	IEEE 802.11n 5 GHz 40 MHz U-NII Band II-C	5510 - 5670
	IEEE 802.11n 5 GHz 40 MHz U-NII Band III	5755 - 5795
	IEEE 802.11ac 80 MHz U-NII Band I	5210
	IEEE 802.11ac 80 MHz U-NII Band II-A	5290
	IEEE 802.11ac 80 MHz U-NII Band II-C	5530 - 5610
	IEEE 802.11ac 80 MHz U-NII Band III	5775
	IEEE 802.11ac 160 MHz UNII Band I + UNII Band II-A	5250
IEEE 802.11ac 160 MHz UNII Band II-C	5570	
Bluetooth BR/EDR	2402 - 2480	
Bluetooth LE	2402 - 2480	



	Operate Modes	Power (dBm)		Tune-up power (dBm)	
		Main	AUX	Main	AUX
Transmit Power (conducted power)	IEEE 802.11b	12.73	12.64	13	13
	IEEE 802.11g	12.69	12.68	13	13
	IEEE 802.11n 2.4 GHz 20 MHz	12.65	12.63	13	13
	IEEE 802.11n 2.4 GHz 40 MHz	12.71	12.47	13	13
	IEEE 802.11a U-NII Band I	10.54	10.53	11	11
	IEEE 802.11a U-NII Band II-A	10.75	10.83	11	11
	IEEE 802.11a U-NII Band II-C	10.67	10.71	11	11
	IEEE 802.11a U-NII Band III	10.91	10.95	11	11
	IEEE 802.11n 5 GHz 20 MHz U-NII Band I	10.67	10.63	11	11
	IEEE 802.11n 5 GHz 20 MHz U-NII Band II-A	10.79	10.70	11	11
	IEEE 802.11n 5 GHz 20 MHz U-NII Band II-C	10.58	10.71	11	11
	IEEE 802.11n 5 GHz 20 MHz U-NII Band III	10.91	10.71	11	11
	IEEE 802.11n 5 GHz 40 MHz U-NII Band I	10.58	10.56	11	11
	IEEE 802.11n 5 GHz 40 MHz U-NII Band II-A	10.88	10.43	11	11
	IEEE 802.11n 5 GHz 40 MHz U-NII Band II-C	10.56	10.62	11	11
	IEEE 802.11n 5 GHz 40 MHz U-NII Band III	10.71	10.77	11	11
	IEEE 802.11ac 80 MHz U-NII Band I	10.57	10.44	11	11
	IEEE 802.11ac 80 MHz U-NII Band II-A	10.61	10.11	11	11
	IEEE 802.11ac 80 MHz U-NII Band II-C (Channel 106)	10.43	10.19	11	11
	IEEE 802.11ac 80 MHz U-NII Band II-C	10.42	10.21	11	11
	IEEE 802.11ac 80 MHz U-NII Band III	10.63	10.17	11	11
	IEEE 802.11ac 160 MHz UNII Band I+ UNII Band II-A	10.52	10.57	11	11
	IEEE 802.11ac 160 MHz UNII Band II-C	10.51	10.43	11	11
	Bluetooth BR	---	10.06	---	11
Bluetooth EDR	---	5.76	---	7	
Bluetooth LE	---	5.49	---	7	
Device Category	Portable Device				
Application Type	Certification				

Note: The above EUT's information was declared by manufacturer. Please refer to the specifications or user's manual for more detailed description.



Antenna list:

Antenna Source	ANT	Manufacturer	Part No. (Vendor)	ASUS Part No.	Type	Frequency	Max. Gain (dBi)
1	Chain A	luxshare-ict	NA02-034011-012HS	04072-03360000	PIFA Antenna	2402 - 2480	-4.15
						5180 - 5240	0.34
						5260 - 5320	0.34
						5500 - 5720	0.24
						5745 - 5825	0.43
	Chain B	luxshare-ict	NA02-034011-012HS	04072-03360000	PIFA Antenna	2402 - 2480	-2.45
						5180 - 5240	-2.26
						5260 - 5320	-2.82
						5500 - 5720	-2.38
						5745 - 5825	-3.14

Note: The Chain A is connected to AUX port / Chain B is connected to Main port of module.



3. Introduction

The A Test Lab Techno Corp. has performed measurements of the maximum potential exposure to the user of **ASUSTeK COMPUTER INC. Trade Name : Intel Model(s) : 9560NGW**. The test procedures, as described in American National Standards, Institute C95.1-1999 [1] were employed and they specify the maximum exposure limit of 1.6 mW/g as averaged over any 1 gram of tissue for portable devices being used within 20 cm between user and EUT in the uncontrolled environment. A description of the product and operating configuration, detailed summary of the test results, methodology and procedures used in the equipment used are included within this test report.

3.1 SAR Definition

Specific Absorption Rate (SAR) is defined as the time derivative (rate) of the incremental energy (dw) absorbed by (dissipated in) an incremental mass (dm) contained in a volume element (dv) of a given density (ρ). The equation description is as below :

$$\text{SAR} = \frac{d}{dt} \left(\frac{dw}{dm} \right) = \frac{d}{dt} \left(\frac{dw}{\rho dv} \right)$$

SAR is expressed in units of Watts per kilogram (W/kg)

SAR measurement can be related to the electrical field in the tissue by

$$\text{SAR} = \frac{\sigma |E|^2}{\rho}$$

Where :

- σ = conductivity of the tissue (S/m)
- ρ = mass density of the tissue (kg/m³)
- E = RMS electric field strength (V/m)

4. SAR Measurement Setup

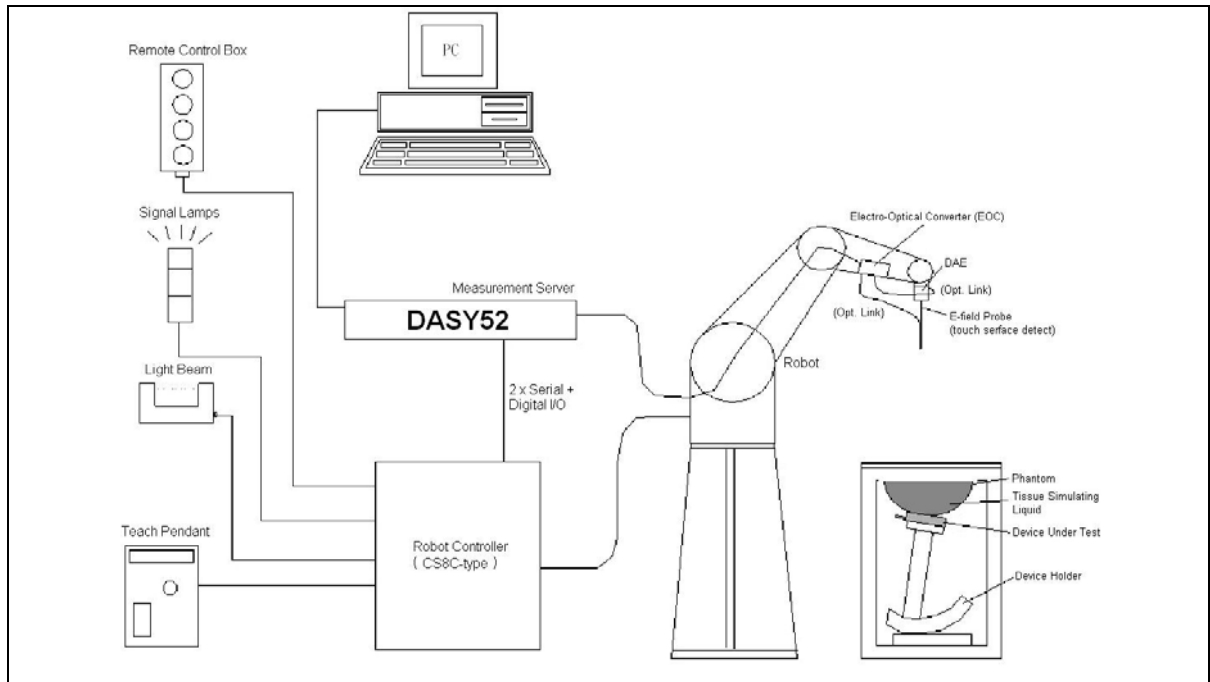

The DASY52 system for performing compliance tests consists of the following items:

1. A standard high precision 6-axis robot (Stäubli TX family) with controller, teach pendant and software. An arm extension for accommodating the data acquisition electronics (DAE).
2. A dosimetric probe, i.e., an isotropic E-field probe optimized and calibrated for usage in tissue simulating liquid. The probe is equipped with an optical surface detector system.
3. A data acquisition electronics (DAE) which performs the signal amplification, signal multiplexing, AD-conversion, offset measurements, mechanical surface detection, collision detection, etc. The unit is battery powered with standard or rechargeable batteries. The signal is optically transmitted to the EOC.
4. The function of the measurement server is to perform the time critical tasks such as signal filtering, control of the robot operation and fast movement interrupts.
5. A probe alignment unit which improves the (absolute) accuracy of the probe positioning.
6. A computer operating Windows 2000 or Windows XP.
7. DASY52 software.
8. Remote controls with teach pendant and additional circuitry for robot safety such as warning lamps, etc.
9. The SAM twin phantom enabling testing left-hand and right-hand usage.
10. The device holder for handheld mobile phones.
11. Tissue simulating liquid mixed according to the given recipes.
12. Validation dipole kits allowing validating the proper functioning of the system.

4.1 DASY E-Field Probe System

The SAR measurements were conducted with the dosimetric probe (manufactured by SPEAG), designed in the classical triangular configuration [3] and optimized for dosimetric evaluation. The probe is constructed using the thick film technique; with printed resistive lines on ceramic substrates. The probe is equipped with an optical multi-fiber line ending at the front of the probe tip. It is connected to the EOC box on the robot arm and provides an automatic detection of the phantom surface. Half of the fibers are connected to a pulsed infrared transmitter, the other half to a synchronized receiver. As the probe approaches the surface, the reflection from the surface produces a coupling from the transmitting to the receiving fibers. This reflection increases first during the approach, reaches maximum and then decreases. If the probe is flatly touching the surface, the coupling is zero. The distance of the coupling maximum to the surface is independent of the surface reflectivity and largely independent of the surface to probe angle. The DASY software reads the reflection during a software approach and looks for the maximum using a 2nd order fitting. The approach is stopped when reaching the maximum.

4.1.1 E-Field Probe Specification

Construction	Symmetrical design with triangular core Built-in shielding against static charges PEEK enclosure material (resistant to organic solvents, e.g., DGBE)
Calibration	ISO/IEC 17025 calibration service available
Frequency	10 MHz to > 6 GHz Linearity: ± 0.2 dB (30 MHz to 6 GHz)
Directivity	± 0.3 dB in brain tissue (rotation around probe axis) ± 0.5 dB in brain tissue (rotation normal probe axis)
Dimensions	Overall length: 337 mm (Tip: 20 mm) Tip diameter: 2.5 mm (Body: 12 mm) Typical distance from probe tip to dipole centers: 1 mm

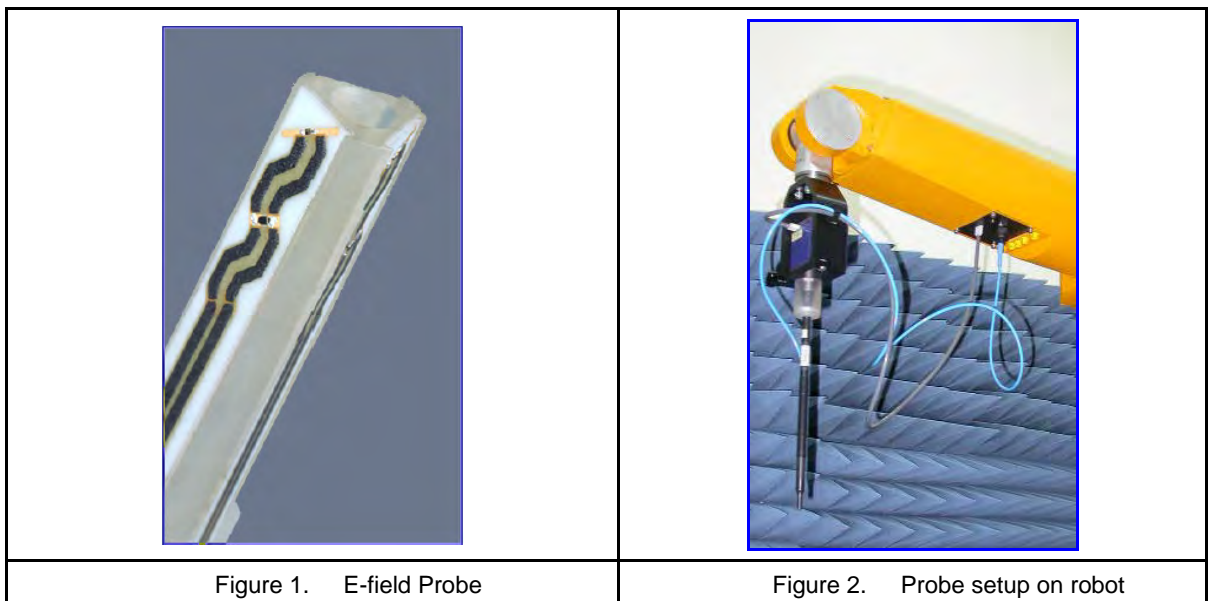



4.2 Data Acquisition Electronic (DAE) System

Model : DAE3, DAE4
Construction : Signal amplifier, multiplexer, A/D converter and control logic. Serial optical link for communication with DASY4/5 embedded system (fully remote controlled). Two step probe touch detector for mechanical surface detection and emergency robot stop.
Measurement Range : -100 to +300 mV (16 bit resolution and two range settings: 4 mV, 400 mV)
Input Offset Voltage : < 5 μ V (with auto zero)
Input Bias Current : < 50 fA
Dimensions : 60 x 60 x 68 mm

4.3 Robot

Positioner : Stäubli Unimation Corp. Robot Model: TX90XL
Repeatability : ± 0.02 mm
No. of Axis : 6

4.4 Measurement Server

Processor : PC/104 with a 400MHz intel ULV Celeron
I/O-board : Link to DAE4 (or DAE3)
16-bit A/D converter for surface detection system
Digital I/O interface
Serial link to robot
Direct emergency stop output for robot

4.5 Device Holder

The DASY device holder is constructed of low-loss POM material having the following dielectric parameters: relative permittivity $\epsilon=3$ and loss tangent $\delta=0.02$. The amount of dielectric material has been reduced in the closest vicinity of the device, since measurements have suggested that the influence of the clamp on the test results could thus be lowered.

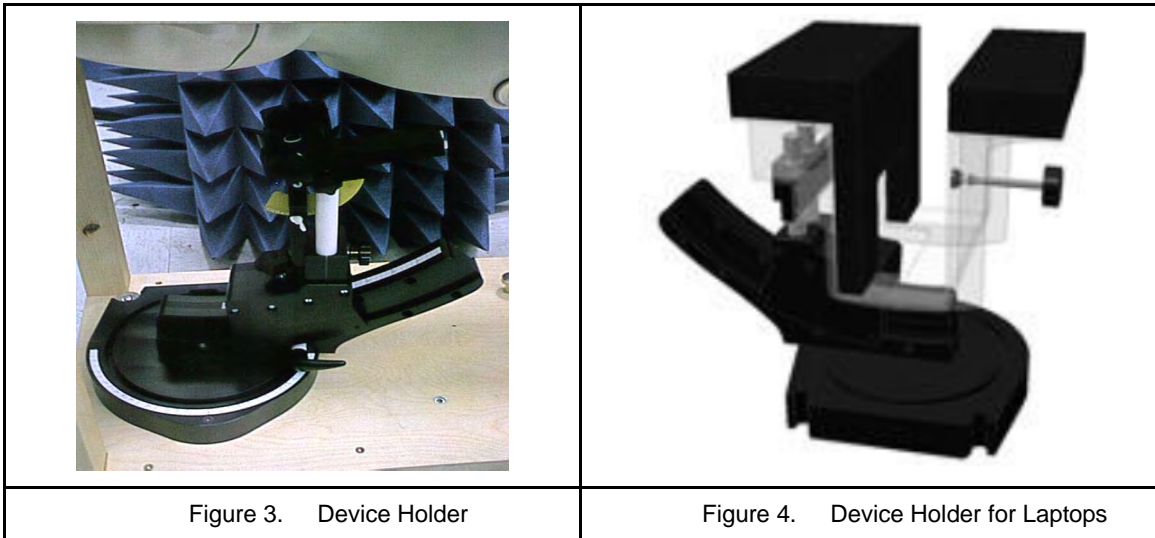

4.6 Oval Flat Phantom - ELI 5.0

The shell corresponds to the specifications of the Specific Anthropomorphic Mannequin (Oval Flat) phantom defined in IEEE 1528-2013, CENELEC 50361 and IEC 62209-2. It enables the dosimetric evaluation of wireless portable device usage as well as body mounted usage at the flat phantom region. A cover prevents evaporation of the liquid. Reference markings on the phantom allow the complete setup of all predefined phantom positions and measurement grids by manually teaching three points with the robot.

Shell Thickness	2 ±0.2 mm
Filling Volume	Approx. 30 liters
Dimensions	190x600x400 mm (HxLxW)
Table 1. Specification of ELI 5.0	

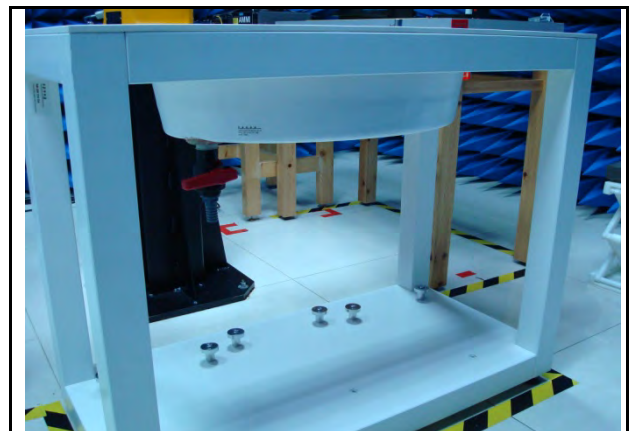

Figure 1. Oval Flat Phantom



5. Tissue Simulating Liquids

IEEE SCC-34/SC-2 in 1528 recommended Tissue Dielectric Parameters

The head tissue dielectric parameters recommended by the IEEE SCC-34/SC-2 in 1528 have been incorporated in the following table. These head parameters are derived from planar layer models simulating the highest expected SAR for the dielectric properties and tissue thickness variations in human head. Other head and body tissue parameters that have not been specified in 1528 are derived from the tissue dielectric parameters computed from the 4-Cole-Cole equation and extrapolated according to the head parameter specified in 1528.

Target Frequency (MHz)	Head		Body	
	ϵ_r	σ (S/m)	ϵ_r	σ (S/m)
150	52.3	0.76	61.9	0.80
300	45.3	0.87	58.2	0.92
450	43.5	0.87	56.7	0.94
835	41.5	0.90	55.2	0.97
900	41.5	0.97	55.0	1.05
915	41.5	0.98	55.0	1.06
1450	40.5	1.20	54.0	1.30
1610	40.3	1.29	53.8	1.40
1800 - 2000	40.0	1.40	53.3	1.52
2450	39.2	1.80	52.7	1.95
3000	38.5	2.40	52.0	2.73
5800	35.3	5.27	48.2	6.00

(ϵ_r = relative permittivity, σ = conductivity and $\rho = 1000 \text{ kg/m}^3$)

Table 2. Tissue dielectric parameters for head and body phantoms



5.1 The composition of the tissue simulating liquid

Ingredients (% by weight)	Frequency (MHz)												Frequency (GHz)	
	750		835		1750		1900		2450		2600		5 GHz	
Tissue Type	Head	Body	Head	Body	Head	Body	Head	Body	Head	Body	Head	Body	Head	Body
Water	39.28	51.30	41.45	52.40	54.50	40.20	54.90	40.40	62.70	73.20	60.30	71.40	65.5	78.6
Salt (NaCl)	1.47	1.42	1.45	1.50	0.17	0.49	0.18	0.50	0.50	0.10	0.60	0.20	0.00	0.00
Sugar	58.15	46.18	56.00	45.00	0.00	0.00	0.00	0.00	0.00	0.00	0.00	0.00	0.00	0.00
HEC	1.00	1.00	1.00	1.00	0.00	0.00	0.00	0.00	0.00	0.00	0.00	0.00	0.00	0.00
Bactericide	0.10	0.10	0.10	0.10	0.00	0.00	0.00	0.00	0.00	0.00	0.00	0.00	0.00	0.00
Triton X-100	0.00	0.00	0.00	0.00	0.00	0.00	0.00	0.00	0.00	0.00	0.00	0.00	17.2	10.7
DGBE	0.00	0.00	0.00	0.00	45.33	59.31	44.92	59.10	36.80	26.70	39.10	28.40	0.00	0.00
Diethylene Glycol Mono-hexlether	0.00	0.00	0.00	0.00	0.00	0.00	0.00	0.00	0.00	0.00	0.00	0.00	17.3	10.7
Dielectric Constant	41.88	54.60	42.54	56.10	40.10	53.60	39.90	54.00	39.80	52.50	39.80	52.50	35.1~ 36.2	47.9~ 49.3
Conductivity (S/m)	0.90	0.97	0.91	0.95	1.39	1.49	1.42	1.45	1.88	1.78	1.88	1.78	4.45~ 5.48	5.07~ 6.23



5.2 Liquid Parameters

The dielectric parameters of the liquids were verified prior to the SAR evaluation using an 85070C Dielectric Probe Kit and an E5071B Network Analyzer.

Tissue Temp (°C)	Head / Body	Frequency (MHz)	Cond.	Perm.	target Cond.	target Perm.	σ (Delta) (%)	ϵ_r (Delta) (%)	Limit (%)	Date
			σ	ϵ_r	σ	ϵ_r				
22.2	Body	2402 MHz	1.96	54.130	1.90	52.76	2.73	2.60	±5	Apr. 04, 2019
22.2	Body	2441 MHz	2.00	53.968	1.94	52.71	3.25	2.39	±5	Apr. 04, 2019
22.2	Body	2480 MHz	2.05	53.843	1.99	52.66	3.01	2.25	±5	Apr. 04, 2019
22.2	Body	2412 MHz	1.97	54.101	1.91	52.75	2.82	2.56	±5	Apr. 04, 2019
22.2	Body	2437 MHz	2.00	53.986	1.94	52.72	3.15	2.40	±5	Apr. 04, 2019
22.2	Body	2462 MHz	2.03	53.892	1.97	52.68	3.25	2.30	±5	Apr. 04, 2019
22.2	Body	2450 MHz	2.02	53.933	1.95	52.70	3.33	2.34	±5	Apr. 04, 2019
22.3	Body	5290 MHz	5.32	50.016	5.40	48.89	-1.65	2.30	±5	Apr. 05, 2019
22.3	Body	5530 MHz	5.69	49.362	5.68	48.57	0.12	1.63	±5	Apr. 05, 2019
22.3	Body	5610 MHz	5.82	49.285	5.78	48.46	0.71	1.70	±5	Apr. 05, 2019
22.3	Body	5690 MHz	5.98	48.919	5.87	48.35	1.77	1.18	±5	Apr. 05, 2019
22.3	Body	5775 MHz	6.10	48.587	5.97	48.23	2.14	0.74	±5	Apr. 05, 2019
22.3	Body	5250 MHz	5.29	50.197	5.36	48.95	-1.33	2.55	±5	Apr. 05, 2019
22.3	Body	5600 MHz	5.81	49.308	5.77	48.47	0.83	1.73	±5	Apr. 05, 2019
22.3	Body	5750 MHz	6.03	48.787	5.94	48.27	1.55	1.07	±5	Apr. 05, 2019

5.3 Liquid Depth

According to KDB865664, the depth of tissue-equivalent liquid in a phantom must be ≥ 15.0 cm.

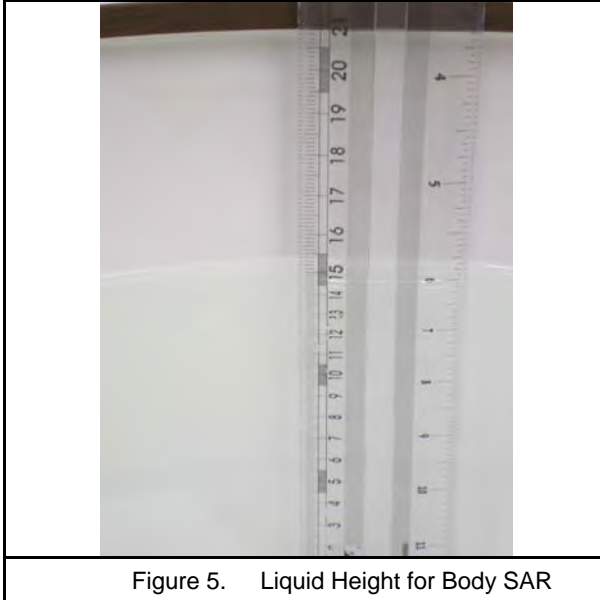

Figure 5. Liquid Height for Body SAR



6. SAR Testing with RF Transmitters

6.1 WLAN RF Conducted Power

SAR test reduction for 802.11 Wi-Fi transmission mode configurations are considered separately for DSSS and OFDM. An initial test position is determined to reduce the number of tests required for certain exposure configurations with multiple test positions. An initial test configuration is determined for each frequency band and aggregated band according to maximum output power, channel bandwidth, wireless mode configurations and other operating parameters to streamline the measurement requirements. For 2.4 GHz DSSS, either the initial test position or DSSS procedure is applied to reduce the number of SAR tests; these are mutually exclusive. For OFDM, an initial test position is only applicable to next to the ear, UMPC mini-tablet and hotspot mode configurations, which is tested using the initial test configuration to facilitate test reduction. For other exposure conditions with a fixed test position, SAR test reduction is determined using only the initial test configuration.

The multiple test positions require SAR measurements in head, hotspot mode or UMPC mini-tablet configurations may be reduced according to the highest reported SAR determined using the initial test position(s) by applying the DSSS or OFDM SAR measurement procedures in the required wireless mode test configuration(s). The initial test position(s) is measured using the highest measured maximum output power channel in the required wireless mode test configuration(s). When the reported SAR for the initial test position is:

- ≤ 0.4 W/kg, further SAR measurement is not required for the other test positions in that exposure configuration and wireless mode combination within the frequency band or aggregated band. DSSS and OFDM configurations are considered separately according to the required SAR procedures.
- > 0.4 W/kg, SAR is repeated using the same wireless mode test configuration tested in the initial test position to measure the subsequent next closest/smallest test separation distance and maximum coupling test position, on the highest maximum output power channel, until the reported SAR is ≤ 0.8 W/kg or all required test positions are tested.
 - For subsequent test positions with equivalent test separation distance or when exposure is dominated by coupling conditions, the position for maximum coupling condition should be tested.
 - When it is unclear, all equivalent conditions must be tested.
- For all positions/configurations tested using the initial test position and subsequent test positions, when the reported SAR is > 0.8 W/kg, measure the SAR for these positions/configurations on the subsequent next highest measured output power channel(s) until the reported SAR is ≤ 1.2 W/kg or all required test channels are considered.
 - The additional power measurements required for this step should be limited to those necessary for identifying subsequent highest output power channels to apply the test reduction.
- When the specified maximum output power is the same for both UNII 1 and UNII 2A, begin SAR measurements in UNII 2A with the channel with the highest measured output power. If the reported SAR for UNII 2A is ≤ 1.2 W/kg, SAR is not required for UNII 1; otherwise treat the remaining bands separately and test them independently for SAR.
- When the specified maximum output power is different between UNII 1 and UNII 2A, begin SAR with the band that has the higher specified maximum output. If the highest reported SAR for the band with the highest specified power is ≤ 1.2 W/kg, testing for the band with the lower specified output power is not required; otherwise test the remaining bands independently for SAR.

To determine the initial test position, Area Scans were performed to determine the position with the Maximum Value of SAR (measured). The position that produced the highest Maximum Value of SAR is considered the worst case position; thus used as the initial test position.



6.2 Conducted Power

Band	Data Rate	CH	Frequency (MHz)	Average Power (dBm)	
				MAIN (Chain B)	AUX (Chain A)
IEEE 802.11b	1M	1	2412.0	12.45	12.41
		6	2437.0	12.65	12.61
		11	2462.0	12.73	12.64
		12	2467.0	12.68	12.41
		13	2472.0	12.71	12.61
IEEE 802.11g	6M	1	2412.0	12.69	12.33
		6	2437.0	12.69	12.47
		11	2462.0	12.61	12.46
		12	2467.0	12.39	12.68
		13	2472.0	-7.54	-6.70
IEEE 802.11n 2.4 GHz 20 MHz	6.5M	1	2412.0	12.65	12.37
		6	2437.0	12.62	12.47
		11	2462.0	12.61	12.49
		12	2467.0	12.38	12.63
		13	2472.0	-7.61	-6.70
IEEE 802.11n 2.4 GHz 40 MHz	13.5M	3	2422.0	12.28	11.97
		6	2437.0	12.71	12.47
		9	2452.0	12.31	12.02
		10	2457.0	9.41	10.32
		11	2462.0	2.61	2.34



Band	Data Rate	CH	Frequency (MHz)	Average Power (dBm)	
				MAIN (Chain B)	AUX (Chain A)
IEEE 802.11a	6M	36	5180.0	10.54	10.53
		40	5200.0	10.51	10.52
		44	5220.0	10.46	10.53
		48	5240.0	10.48	10.48
		52	5260.0	10.64	10.80
		56	5280.0	10.75	10.83
		60	5300.0	10.62	10.72
		64	5320.0	10.52	10.52
		100	5500.0	10.48	10.54
		104	5520.0	10.38	10.61
		108	5540.0	10.31	10.53
		112	5560.0	10.42	10.46
		116	5580.0	10.52	10.71
		120	5600.0	10.67	10.61
		124	5620.0	10.41	10.53
		128	5640.0	10.29	10.59
		132	5660.0	10.21	10.61
		136	5680.0	10.34	10.51
		140	5700.0	10.41	10.39
		149	5745.0	10.91	10.92
153	5765.0	10.81	10.83		
157	5785.0	10.89	10.81		
161	5805.0	10.81	10.86		
165	5825.0	10.67	10.95		



Band	Data Rate	CH	Frequency (MHz)	Average Power (dBm)	
				MAIN (Chain B)	AUX (Chain A)
IEEE 802.11n 5 GHz 20 MHz	6.5M	36	5180.0	10.53	10.43
		40	5200.0	10.67	10.63
		44	5220.0	10.48	10.58
		48	5240.0	10.51	10.52
		52	5260.0	10.69	10.70
		56	5280.0	10.79	10.67
		60	5300.0	10.49	10.63
		64	5320.0	10.46	10.48
		100	5500.0	10.47	10.41
		104	5520.0	10.28	10.52
		108	5540.0	10.17	10.67
		112	5560.0	10.36	10.43
		116	5580.0	10.32	10.69
		120	5600.0	10.58	10.62
		124	5620.0	10.28	10.71
		128	5640.0	10.24	10.67
		132	5660.0	10.29	10.65
		136	5680.0	10.25	10.71
		140	5700.0	10.46	10.34
		149	5745.0	10.84	10.71
153	5765.0	10.75	10.68		
157	5785.0	10.91	10.56		
161	5805.0	10.71	10.61		
165	5825.0	10.67	10.69		



Band	Data Rate	CH	Frequency (MHz)	Average Power (dBm)	
				MAIN (Chain B)	AUX (Chain A)
IEEE 802.11n 5 GHz 40 MHz	13.5M	38	5190.0	10.46	10.56
		46	5230.0	10.58	10.38
		54	5270.0	10.88	10.42
		62	5310.0	10.57	10.43
		102	5510.0	10.41	10.53
		110	5550.0	10.52	10.56
		118	5590.0	10.41	10.62
		126	5630.0	10.52	10.56
		134	5670.0	10.56	10.57
		151	5755.0	10.70	10.75
		159	5795.0	10.71	10.77
IEEE 802.11ac 80 MHz	29.3M	42	5210.0	10.57	10.44
		58	5290.0	10.61	10.11
		106	5530.0	10.43	10.19
		122	5610.0	10.42	10.21
		155	5775.0	10.63	10.17
IEEE 802.11ac 160 MHz	65M	50	5250.0	10.52	10.57
		114	5570.0	10.51	10.43

Band	CH	Frequency (MHz)	Average Power (dBm)	
			MAIN (Chain B)	AUX (Chain A)
Bluetooth BR	0	2402.0	---	9.48
	39	2441.0	---	10.06
GFSK	78	2480.0	---	10.05
	0	2402.0	---	5.67
Bluetooth EDR	39	2441.0	---	5.76
	78	2480.0	---	5.17

Band	CH	Frequency (MHz)	Bandwidth	Average Power (dBm)	
				MAIN (Chain B)	AUX (Chain A)
Bluetooth LE	0	2402.0	1M	---	5.45
	19	2440.0		---	5.49
	39	2480.0		---	4.98

6.3 Antenna location

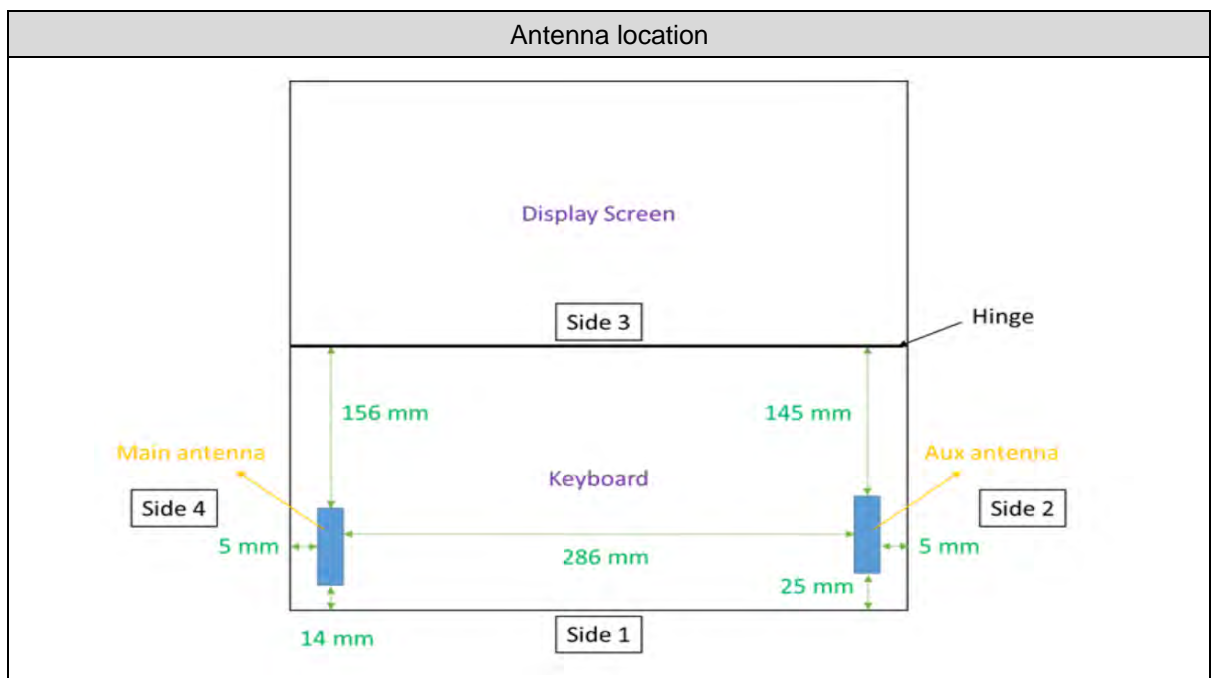



6.4 Standalone SAR Test Exclusion Calculation

We did not simplify any test configurations, except for following KDB 248227, so there was no provide results of the test exclusion in KDB 447498 D01.

6.5 Simultaneous Transmitting Evaluate

Simultaneous transmission configurations as below:

Condition	Band				
	WLAN 2.4 GHz ANT-Main	WLAN 2.4 GHz ANT-AUX	WLAN 5 GHz ANT-Main	WLAN 5 GHz ANT-AUX	Bluetooth ANT-AUX
1	V	---	---	---	V
2	V	V	---	---	---
3	---	---	V	---	V
4	---	---	V	V	---
5	---	---	V	V	V

6.5.1 Sum of 1-g SAR of all simultaneously transmitting

When the sum of 1-g SAR of all simultaneously transmitting antennas in an operating mode and exposure condition combination is within the SAR limit, SAR test exclusion applies to that simultaneous transmission configuration.

Sum of 1-g SAR of summary as below:

Phantom Position		Spacing (mm)	ASSY	2.4 GHz WLAN ANT-Main (1)		2.4 GHz WLAN ANT-AUX (2)	
				Band	SAR _{1g} (W/Kg)	Band	SAR _{1g} (W/Kg)
Flat	Bottom of laptop	0	N/A	IEEE 802.11b	1.10	IEEE 802.11b	0.42

Phantom Position		Spacing (mm)	ASSY	5 GHz WLAN ANT-Main (3)		5 GHz WLAN ANT-AUX (4)		Bluetooth ANT-AUX (5)	
				Band	SAR _{1g} (W/Kg)	Band	SAR _{1g} (W/Kg)	Band	SAR _{1g} (W/Kg)
Flat	Bottom of laptop	0	N/A	IEEE 802.11ac 80 MHz	1.00	IEEE 802.11ac 80 MHz	1.11	Bluetooth	0.18

Phantom Position		Spacing (mm)	ASSY	(1) + (5)	(1) + (2)	(3) + (5)	(3) + (4)	(3) + (4) + (5)
				\sum SAR _{1g} (W/Kg)	\sum SAR _{1g} (W/Kg)	\sum SAR _{1g} (W/Kg)	\sum SAR _{1g} (W/Kg)	\sum SAR _{1g} (W/Kg)
Flat	Bottom of laptop	0	N/A	1.28	1.52	1.16	2.11	2.29



6.5.2 SAR to peak location separation ratio (SPLSR)

When the sum of SAR is larger than the limit, SAR test exclusion is determined by the SAR to peak location separation ratio. The ratio is determined by $(SAR_1 + SAR_2)^{1.5}/R_i$, rounded to two decimal digits, and must be ≤ 0.04 for all antenna pairs in the configuration to qualify for 1-g SAR test exclusion.

5 GHz Main + 5 GHz AUX

Antenna	Plot.	Frequency (GHz)	SAR _{1g} (W/Kg)	Σ SAR _{1g} (W/Kg)	Antenna pair (mm)	Peak location separation ratio
5 GHz Main	5	5.29	0.914	1.82	302.4	0.01
5 GHz AUX	6	5.29	0.901			

Maxima and position w.r.t. Grid Reference Point		associated 1g averages
Zoom Scan (D:\Test Date\2019\4\19-0207-SER_ASUS_Intel9560 (X432)\FCC\DA52\5g\5_IEEE 802.11ac 80 CH58_MCS0_Bottom of laptop_0mm_ant Main.da53:0/Flat)		0.91 W/kg
Max. 1 at (-59.20, -160.20, -0.80) mm		
Zoom Scan (D:\Test Date\2019\4\19-0207-SER_ASUS_Intel9560 (X432)\FCC\DA52\5g\6_IEEE 802.11ac 80 CH58_MCS0_Bottom of laptop_0mm_ant AUX.da53:0/Flat)		0.90 W/kg
Max. 2 at (-74.80, 141.80, -1.10) mm		
Distances and Separation Ratios		
Max. 1 - Max. 2		Distance [mm]: 302.40 / Separation ratio [W/kg/mm]: 0.01

5 GHz Main + 5 GHz AUX + Bluetooth AUX

Antenna	Plot.	Frequency (GHz)	SAR _{1g} (W/Kg)	Σ SAR _{1g} (W/Kg)	Antenna pair (mm)	Peak location separation ratio
5 GHz Main	5	5.29	0.914	1.911	302.4	0.01
5 GHz AUX	6	5.29	0.901			
Bluetooth AUX	16	2.441	0.096			

5 GHz Main + 5GHz AUX

Maxima and position w.r.t. Grid Reference Point		associated 1g averages
Zoom Scan (D:\Test Date\2019\4\19-0207-SER_ASUS_Intel9560 (X432)\FCC\DA52\5g\5_IEEE 802.11ac 80 CH58_MCS0_Bottom of laptop_0mm_ant Main.da53:0/Flat)		0.91 W/kg
Max. 1 at (-59.20, -160.20, -0.80) mm		
Zoom Scan (D:\Test Date\2019\4\19-0207-SER_ASUS_Intel9560 (X432)\FCC\DA52\5g\6_IEEE 802.11ac 80 CH58_MCS0_Bottom of laptop_0mm_ant AUX.da53:0/Flat)		0.90 W/kg
Max. 2 at (-74.80, 141.80, -1.10) mm		
Distances and Separation Ratios		
Max. 1 - Max. 2		Distance [mm]: 302.40 / Separation ratio [W/kg/mm]: 0.01

5 GHz Main + Bluetooth AUX

Maxima and position w.r.t. Grid Reference Point		associated 1g averages
Zoom Scan (D:\Test Date\2019\4\19-0207-SER_ASUS_Intel9560 (X432)\FCC\DA52\5g\5_IEEE 802.11ac 80 CH58_MCS0_Bottom of laptop_0mm_ant Main.da53:0/Flat)		0.91 W/kg
Max. 1 at (-59.20, -160.20, -0.80) mm		
Zoom Scan (D:\Test Date\2019\4\19-0207-SER_ASUS_Intel9560 (X432)\FCC\DA52\2.4\15_Bluetooth CH0_1M_Bottom of laptop_0mm_ant A_Aux.da53:0/Flat)		0.10 W/kg
Max. 2 at (-75.60, 140.00, -0.77) mm		
Distances and Separation Ratios		
Max. 1 - Max. 2		Distance [mm]: 300.65 / Separation ratio [W/kg/mm]: 0.00

7. System Verification and Validation

7.1 Symmetric Dipoles for System Verification

Construction	Symmetrical dipole with 1/4 balun enables measurement of feed point impedance with NWA matched for use near flat phantoms filled with head simulating solutions Includes distance holder and tripod adaptor Calibration Calibrated SAR value for specified position and input power at the flat phantom in head simulating solutions.
Return Loss	> 20 dB at specified verification position
Options	Dipoles for other frequencies or solutions and other calibration conditions are available upon request

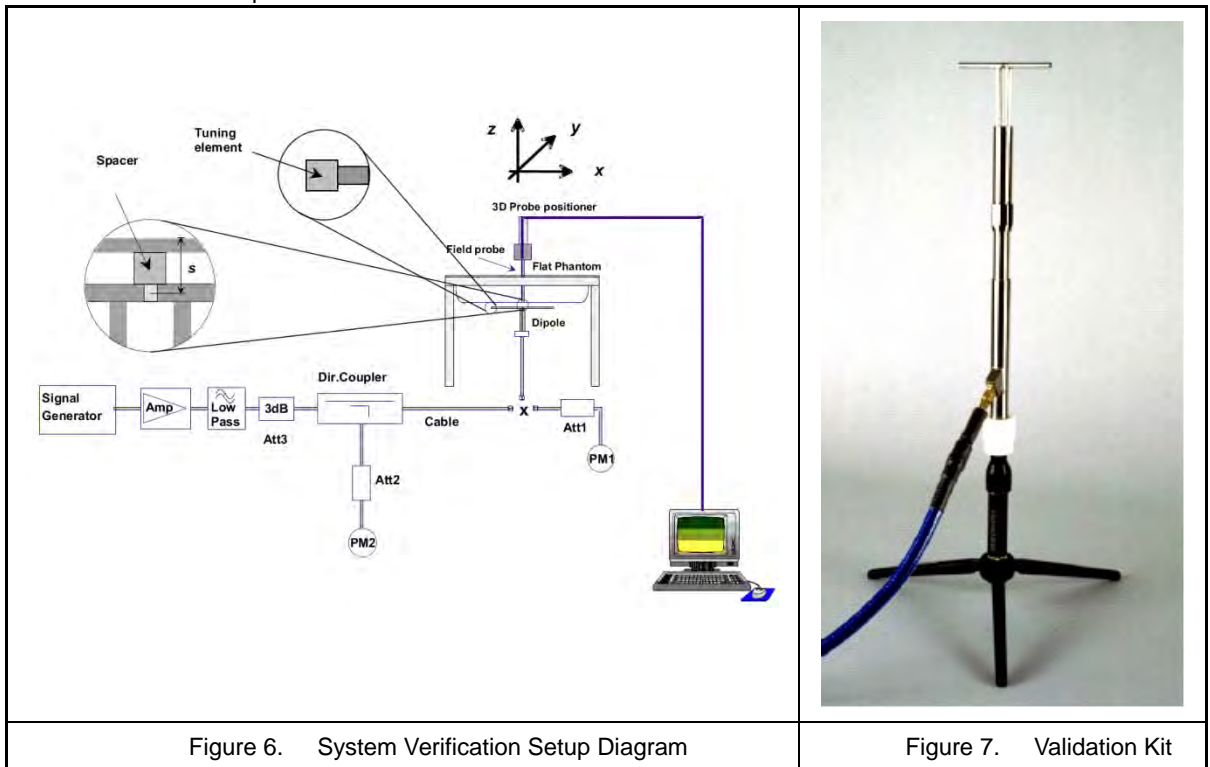

Figure 6. System Verification Setup Diagram



Figure 7. Validation Kit



7.2 Verification Summary

Prior to the assessment, the system validation kit was used to test whether the system was operating within its specifications of $\pm 10\%$. The measured SAR will be normalized to 1 W input power. The verification was performed at 2450, 5250, 5500 and 5750 MHz.

Mixture Type	Frequency (MHz)	Power	Probe Model / Serial No.	Dipole Model / Serial No.	SAR _{1g} (W/Kg)	SAR _{10g} (W/Kg)	1 W Target		Difference percentage		Date
							SAR _{1g} [W/kg]	SAR _{10g} [W/kg]	1 g	10 g	
Body	2450	250 mW	EX3DV4-SN3977	D2450V2-SN735	13	5.95	50.20	23.70	3.5 %	0.4 %	Apr. 04, 2019
		Normalize to 1 Watt			52.00	23.80					
Body	5250	100 mW	EX3DV4-SN3977	D5250V2-SN1203	7.34	2.08	74.90	20.90	-2.0 %	-0.5 %	Apr. 05, 2019
		Normalize to 1 Watt			73.40	20.80					
Body	5600	100 mW	EX3DV4-SN3977	D5600V2-SN1203	7.88	2.19	79.70	22.30	-1.1 %	-1.8 %	Apr. 05, 2019
		Normalize to 1 Watt			78.80	21.90					
Body	5750	100 mW	EX3DV4-SN3977	D5750V2-SN1203	7.62	2.11	76.80	21.30	-0.8 %	-0.9 %	Apr. 05, 2019
		Normalize to 1 Watt			76.20	21.10					



8. Test Equipment List

Manufacturer	Name of Equipment	Type/Model	Serial Number	Calibration	
				Cal. Date	Cal.Period
SPEAG	2450 MHz System Validation Kit	D2450V2	735	12/11/2018	1 year
SPEAG	5 GHz System Validation Kit	D5GHzV2	1203	12/13/2018	1 year
SPEAG	Dosimetric E-Field Probe	EX3DV4	3977	08/30/2018	1 year
SPEAG	Data Acquisition Electronics	DAE4	779	08/14/2018	1 year
SPEAG	Measurement Server	SE UMS 011 AA	1025	NCR	
SPEAG	Device Holder	N/A	N/A	NCR	
SPEAG	Phantom	ELI V5.0	1133	NCR	
SPEAG	Robot	Staubli TX90XL	F16/54FTA1/A/01	NCR	
SPEAG	Software	DASY52 V52.10 (0)	N/A	NCR	
SPEAG	Software	SEMCAD X V14.6.10(7331)	N/A	NCR	
Agilent	ENA Series Network Analyzer	E5071B	MY42404655	04/17/2018	1 year
Agilent	Dielectric Probe Kit	85070C	US99360094	NCR	
HILA	Digital Thermometer	TM-906	GF-006	05/22/2018	1 year
Agilent	Power Sensor	8481H	3318A20779	06/12/2018	1 year
Agilent	Power Meter	EDM Series E4418B	GB40206143	06/12/2018	1 year
Agilent	Signal Generator	E8257D	MY44320425	03/05/2019	1 year
Agilent	Dual Directional Coupler	778D	50334	NCR	
Woken	Dual Directional Coupler	0100AZ20200801O	11012409517	NCR	
Mini-Circuits	Power Amplifier	EMC014225P	980292	NCR	
Mini-Circuits	Power Amplifier	EMC2830P	980293	NCR	
Aisi	Attenuator	IEAT 3dB	N/A	NCR	

Table 1. Test Equipment List



9. Measurement Uncertainty

Item	Uncertainty Component	Uncertainty Value	Prob. Dist	Div.	c_i (1 g)	c_i (10 g)	Std. Unc. (1-g)	Std. Unc. (10-g)	v_i or v_{eff}
Measurement System									
u1	Probe Calibration ($k=1$)	±6.0 %	Normal	1	1	1	±6.0 %	±6.0 %	∞
u2	Axial Isotropy	±4.7 %	Rectangular	$\sqrt{3}$	0.7	0.7	±1.9 %	±1.9 %	∞
u3	Hemispherical Isotropy	±9.6 %	Rectangular	$\sqrt{3}$	0.7	0.7	±3.9 %	±3.9 %	
u4	Boundary Effect	±1.0 %	Rectangular	$\sqrt{3}$	1	1	±0.6 %	±0.6 %	∞
u5	Linearity	±4.7 %	Rectangular	$\sqrt{3}$	1	1	±2.7 %	±2.7 %	∞
u6	System Detection Limit	±1.0 %	Rectangular	$\sqrt{3}$	1	1	±0.6 %	±0.6 %	∞
u7	Readout Electronics	±0.3 %	Normal	1	1	1	±0.3 %	±0.3 %	∞
u8	Response Time	±0.8 %	Rectangular	$\sqrt{3}$	1	1	±0.5 %	±0.5 %	∞
u9	Integration Time	±1.9 %	Rectangular	$\sqrt{3}$	1	1	±1.1 %	±1.1 %	∞
u10	RF Ambient Conditions	±3.0 %	Rectangular	$\sqrt{3}$	1	1	±1.7 %	±1.7 %	∞
u11	RF Ambient Reflections	±3.0 %	Rectangular	$\sqrt{3}$	1	1	±1.7 %	±1.7 %	∞
u12	Probe Positioner Mechanical Tolerance	±0.4 %	Rectangular	$\sqrt{3}$	1	1	±0.2 %	±0.2 %	∞
u13	Probe Positioning with respect to Phantom Shell	±2.9 %	Rectangular	$\sqrt{3}$	1	1	±1.7 %	±1.7 %	∞
u14	Extrapolation, interpolation and integration Algorithms for Max. SAR Evaluation	±1.0 %	Rectangular	$\sqrt{3}$	1	1	±0.6 %	±0.6 %	∞
Test sample Related									
u15	Test sample Positioning	±2.9 %	Normal	1	1	1	±2.9 %	±2.9 %	89
u16	Device Holder Uncertainty	±3.6 %	Normal	1	1	1	±3.6 %	±3.6 %	5
u17	Output Power Variation - SAR drift measurement	±5.0 %	Rectangular	$\sqrt{3}$	1	1	±2.9 %	±2.9 %	∞
Phantom and Tissue Parameters									
u18	Phantom Uncertainty (shape and thickness tolerances)	±4.0 %	Rectangular	$\sqrt{3}$	1	1	±2.3 %	±2.3 %	∞
u19	Liquid Conductivity - deviation from target values	±5.0 %	Rectangular	$\sqrt{3}$	0.64	0.43	±1.8 %	±1.2 %	∞
u20	Liquid Conductivity - measurement uncertainty	±2.5 %	Normal	1	0.64	0.43	±1.6 %	±1.08 %	69
u21	Liquid Permittivity - deviation from target values	±5.0 %	Rectangular	$\sqrt{3}$	0.6	0.49	±1.7 %	±1.4 %	∞
u22	Liquid Permittivity - measurement uncertainty	±2.5 %	Normal	1	0.6	0.49	±1.5 %	±1.23 %	69
Combined standard uncertainty			RSS				±10.94 %	±10.71 %	380
Expanded uncertainty (95 % CONFIDENCE LEVEL)			$k=2$				±21.88 %	±21.41 %	

Table 2. Uncertainty Budget for frequency range 300 MHz to 3 GHz



Item	Uncertainty Component	Uncertainty Value	Prob. Dist	Div.	c_i (1 g)	c_i (10 g)	Std. Unc. (1-g)	Std. Unc. (10-g)	v_i or v_{eff}
Measurement System									
u1	Probe Calibration ($k=1$)	±6.5 %	Normal	1	1	1	±6.5 %	±6.5 %	∞
u2	Axial Isotropy	±4.7 %	Rectangular	$\sqrt{3}$	0.7	0.7	±1.9 %	±1.9 %	∞
u3	Hemispherical Isotropy	±9.6 %	Rectangular	$\sqrt{3}$	0.7	0.7	±3.9 %	±3.9 %	
u4	Boundary Effect	±2.0 %	Rectangular	$\sqrt{3}$	1	1	±1.2 %	±1.2 %	∞
u5	Linearity	±4.7 %	Rectangular	$\sqrt{3}$	1	1	±2.7 %	±2.7 %	∞
u6	System Detection Limit	±1.0 %	Rectangular	$\sqrt{3}$	1	1	±0.6 %	±0.6 %	∞
u7	Readout Electronics	±0.0 %	Normal	1	1	1	±0.0 %	±0.0 %	∞
u8	Response Time	±0.8 %	Rectangular	$\sqrt{3}$	1	1	±0.5 %	±0.5 %	∞
u9	Integration Time	±2.8 %	Rectangular	$\sqrt{3}$	1	1	±2.8 %	±2.8 %	∞
u10	RF Ambient Conditions	±3.0 %	Rectangular	$\sqrt{3}$	1	1	±1.7 %	±1.7 %	∞
u11	RF Ambient Reflections	±3.0 %	Rectangular	$\sqrt{3}$	1	1	±1.7 %	±1.7 %	∞
u12	Probe Positioner Mechanical Tolerance	±0.7 %	Rectangular	$\sqrt{3}$	1	1	±0.7 %	±0.7 %	∞
u13	Probe Positioning with respect to Phantom Shell	±9.9 %	Rectangular	$\sqrt{3}$	1	1	±5.7 %	±5.7 %	∞
u14	Extrapolation, interpolation and integration Algorithms for Max. SAR Evaluation	±3.0 %	Rectangular	$\sqrt{3}$	1	1	±1.7 %	±1.7 %	∞
Test sample Related									
u15	Test sample Positioning	±2.9 %	Normal	1	1	1	±2.9 %	±2.9 %	89
u16	Device Holder Uncertainty	±3.6 %	Normal	1	1	1	±3.6 %	±3.6 %	5
u17	Output Power Variation - SAR drift measurement	±5.0 %	Rectangular	$\sqrt{3}$	1	1	±2.9 %	±2.9 %	∞
Phantom and Tissue Parameters									
u18	Phantom Uncertainty (shape and thickness tolerances)	±4.0 %	Rectangular	$\sqrt{3}$	1	1	±2.3 %	±2.3 %	∞
u19	Liquid Conductivity - deviation from target values	±5.0 %	Rectangular	$\sqrt{3}$	0.64	0.43	±1.8 %	±1.2 %	∞
u20	Liquid Conductivity - measurement uncertainty	±2.5 %	Normal	1	0.64	0.43	±1.6 %	±1.08 %	69
u21	Liquid Permittivity - deviation from target values	±5.0 %	Rectangular	$\sqrt{3}$	0.6	0.49	±1.7 %	±1.4 %	∞
u22	Liquid Permittivity - measurement uncertainty	±2.5 %	Normal	1	0.6	0.49	±1.5 %	±1.23 %	69
Combined standard uncertainty			RSS				±12.68 %	±12.48 %	700
Expanded uncertainty (95 % CONFIDENCE LEVEL)			$k=2$				±25.37 %	±24.97 %	

Table 3. Uncertainty Budget for frequency range 3 GHz to 6 GHz



10. Measurement Procedure

The measurement procedures are as follows:

1. For WLAN function, engineering testing software installed on DUTs can provide continuous transmitting signal.
2. Measure output power through RF cable and power meter
3. Set scan area, grid size and other setting on the DASY software
4. Find out the largest SAR result on these testing positions of each band
5. Measure SAR results for other channels in worst SAR testing position if the SAR of highest power channel is larger than 0.8 W/kg

According to the test standard, the recommended procedure for assessing the peak spatial-average SAR value consists of the following steps:

1. Power reference measurement
2. Area scan
3. Zoom scan
4. Power drift measurement

10.1 Spatial Peak SAR Evaluation

The procedure for spatial peak SAR evaluation has been implemented according to the test standard. It can be conducted for 1 g and 10 g, as well as for user-specific masses. The DASY software includes all numerical procedures necessary to evaluate the spatial peak SAR value.

The base for the evaluation is a "cube" measurement. The measured volume must include the 1 g and 10 g cubes with the highest averaged SAR values. For that purpose, the center of the measured volume is aligned to the interpolated peak SAR value of a previously performed area scan.

The entire evaluation of the spatial peak values is performed within the post-processing engine (SEMCAD). The system always gives the maximum values for the 1 g and 10 g cubes. The algorithm to find the cube with highest averaged SAR is divided into the following stages

1. Extraction of the measured data (grid and values) from the Zoom Scan
2. Calculation of the SAR value at every measurement point based on all stored data (A/D values and measurement parameters)
3. Generation of a high-resolution mesh within the measured volume
4. Interpolation of all measured values from the measurement grid to the high-resolution grid
5. Extrapolation of the entire 3-D field distribution to the phantom surface over the distance from sensor to surface
6. Calculation of the averaged SAR within masses of 1 g and 10 g



10.2 Area & Zoom Scan Procedures

First Area Scan is used to locate the approximate location(s) of the local peak SAR value(s). The measurement grid within an Area Scan is defined by the grid extent, grid step size and grid offset. Next, in order to determine the EM field distribution in a three-dimensional spatial extension, Zoom Scan is required. The Zoom Scan measures points and step size follow as below. The Zoom Scan is performed around the highest E-field value to determine the averaged SAR-distribution over 10 g.

Grid Type	Frequency		Step size (mm)			X*Y*Z (Point)	Cube size			Step size		
			X	Y	Z		X	Y	Z	X	Y	Z
uniform grid	≤ 3 GHz	≤ 2 GHz	≤ 8	≤ 8	≤ 5	5*5*7	32	32	30	8	8	5
		2 G – 3 G	≤ 5	≤ 5	≤ 5	7*7*7	30	30	30	5	5	5
	3 – 6 GHz	3 – 4 GHz	≤ 5	≤ 5	≤ 4	7*7*8	30	30	28	5	5	4
		4 – 5 GHz	≤ 4	≤ 4	≤ 3	8*8*10	28	28	27	4	4	3
		5 – 6 GHz	≤ 4	≤ 4	≤ 1.4	8*8*12	24	24	22	4	4	1.4

(Our measure settings are refer KDB Publication 865664 D01v01r04)

10.3 Volume Scan Procedures

The volume scan is used for assess overlapping SAR distributions for antennas transmitting in different frequency bands. It is equivalent to an oversized zoom scan used in standalone measurements. The measurement volume will be used to enclose all the simultaneous transmitting antennas. For antennas transmitting simultaneously in different frequency bands, the volume scan is measured separately in each frequency band. In order to sum correctly to compute the 1 g aggregate SAR, the DUT remain in the same test position for all measurements and all volume scan use the same spatial resolution and grid spacing. When all volume scan were completed, the software, SEMCAD postprocessor can combine and subsequently superpose these measurement data to calculating the multiband SAR.

10.4 Power Drift Monitoring

All SAR testing is under the DUT install full charged battery and transmit maximum output power. In DASY measurement software, the power reference measurement and power drift measurement procedures are used for monitoring the power drift of DUT during SAR test. Both these procedures measure the field at a specified reference position before and after the SAR testing. The software will calculate the field difference in dB. If the power drifts more than 5 %, the SAR will be retested.



11. SAR Test Results Summary

Note:

1. When the reported SAR of the highest measured maximum output power channel is ≤ 0.8 W/kg, no further SAR testing is required for 802.11b DSSS.
2. When the highest reported SAR for DSSS is adjusted by the ratio of OFDM to DSSS specified maximum output power and the adjusted SAR is ≤ 1.2 W/kg, SAR is not required for 2.4G OFDM configuration.
3. SAR for the initial test configuration is measured using the highest maximum output power channel.
4. When the same maximum output power is specified for both bands, begin SAR measurement in U-NII-2A band by applying the OFDM SAR requirements. If the highest reported SAR for a test configuration is ≤ 1.2 W/kg, SAR is not required for U-NII-1 band for that configuration (802.11 mode and exposure condition); otherwise, each band is tested independently for SAR.

11.1 Body SAR Measurement

Measurement Results													
Index	Band	Mode	Frequency		Data Rate	Test Position	Spacing (mm)	SAR _{1g} (W/Kg)	Burst Avg Power	Max tune-up	Duty Cycle %	Reported SAR _{1g}	Note
			Ch.	MHz									
#1	WLAN 2.4 GHz	802.11b	6	2437.0	1 Mbps	Bottom of laptop	0	0.943	12.65	13.00	100	1.02	ANT-Main
#3	WLAN 2.4 GHz	802.11b	1	2412.0	1 Mbps	Bottom of laptop	0	0.879	12.45	13.00	100	1.00	ANT-Main
#4	WLAN 2.4 GHz	802.11b	11	2462.0	1 Mbps	Bottom of laptop	0	1.03	12.73	13.00	100	1.10	ANT-Main
#2	WLAN 2.4 GHz	802.11b	6	2437.0	1 Mbps	Bottom of laptop	0	0.383	12.61	13.00	100	0.42	ANT-AUX
#5	WLAN 5 GHz	802.11ac 80 MHz	58	5290.0	58.6 Mbps	Bottom of laptop	0	0.914	10.61	11.00	100	1.00	ANT-Main
#7	WLAN 5 GHz	802.11ac 80 MHz	106	5530.0	58.6 Mbps	Bottom of laptop	0	0.666	10.43	11.00	100	0.76	ANT-Main
#9	WLAN 5 GHz	802.11ac 80 MHz	122	5610.0	58.6 Mbps	Bottom of laptop	0	0.568	10.42	11.00	100	0.65	ANT-Main
#11	WLAN 5 GHz	802.11ac 80 MHz	138	5690.0	58.6 Mbps	Bottom of laptop	0	0.519	10.54	11.00	100	0.58	ANT-Main
#13	WLAN 5 GHz	802.11ac 80 MHz	155	5775.0	58.6 Mbps	Bottom of laptop	0	0.429	10.63	11.00	100	0.47	ANT-Main
#6	WLAN 5 GHz	802.11ac 80 MHz	58	5290.0	58.6 Mbps	Bottom of laptop	0	0.901	10.11	11.00	100	1.11	ANT-AUX
#8	WLAN 5 GHz	802.11ac 80 MHz	106	5530.0	58.6 Mbps	Bottom of laptop	0	0.719	10.19	11.00	100	0.87	ANT-AUX
#10	WLAN 5 GHz	802.11ac 80 MHz	122	5610.0	58.6 Mbps	Bottom of laptop	0	0.61	10.21	11.00	100	0.73	ANT-AUX
#12	WLAN 5 GHz	802.11ac 80 MHz	138	5690.0	58.6 Mbps	Bottom of laptop	0	0.55	10.38	11.00	100	0.63	ANT-AUX
#14	WLAN 5 GHz	802.11ac 80 MHz	155	5775.0	58.6 Mbps	Bottom of laptop	0	0.493	10.17	11.00	100	0.60	ANT-AUX



Measurement Results													
Index	Band	Mode	Frequency		Data Rate	Test Position	Spacing (mm)	SAR _{1g} (W/Kg)	Burst Avg Power	Max tune-up	Duty Cycle %	Reported SAR _{1g}	Note
			Ch.	MHz									
#15	Bluetooth	---	0	2402.0	---	Bottom of laptop	0	0.096	9.48	11.00	77	0.18	ANT-AUX
#16	Bluetooth	---	39	2441.0	---	Bottom of laptop	0	0.096	10.06	11.00	77	0.16	ANT-AUX
#17	Bluetooth	---	78	2480.0	---	Bottom of laptop	0	0.075	10.05	11.00	77	0.12	ANT-AUX

11.2 SAR Variability Measurement

Measurement Results											
Index	Band	Mode	Frequency		Data Rate	Test Position	Spacing (mm)	Note	Original SAR _{1g} (W/Kg)	First SAR _{1g} (W/Kg)	Ratio SAR _{1g}
			Ch.	MHz							
#18	WLAN 2.4 GHz	802.11b	11	2462.0	1 Mbps	Bottom of laptop	0	original #4_once	1.03	0.965	1.07
#19	WLAN 5 GHz	802.11ac 80 MHz	58	5290.0	58.6 Mbps	Bottom of laptop	0	original #5_once	0.914	0.901	1.01



11.3 SAR Exposure Limit

Human Exposure	Population Uncontrolled Exposure (W/kg)	Occupational Controlled Exposure (W/kg)
Spatial Peak SAR* (head or Body)	1.60	8.00
Spatial Peak SAR** (Whole Body)	0.08	0.40
Spatial Peak SAR*** (Hands / Feet / Ankle / Wrist)	4.00	20.00

Table 4. Safety Limits for Controlled / Uncontrolled Environment Exposure

Notes :

- * The Spatial Peak value of the SAR averaged over any 1 gram of tissue. (defined as a tissue volume in the shape of a cube) and over the appropriate averaging time.
- ** The Spatial Average value of the SAR averaged over the whole – body.
- *** The Spatial Peak value of the SAR averaged over any 10 grams of tissue. (defined as a tissue volume in the shape of a cube) and over the appropriate averaging time.

Population / Uncontrolled Environments : are defined as locations where there is the exposure of individuals who have no knowledge or control of their exposure.

Occupational / Controlled Environments : are defined as locations where there is exposure that may be incurred by persons who are aware of the potential for exposure, (i.e. as a result of employment or occupation).

12. References

- [1] Std. C95.1-1999, "American National Standard safety levels with respect to human exposure to radio frequency electromagnetic fields, 300KHz to 100GHz", New York.
- [2] NCRP, National Council on Radiation Protection and Measurements, "Biological Effects and Exposure Criteria for Radio frequency Electromagnetic Fields", NCRP report NO. 86, 1986.
- [3] T. Schmid, O. Egger, and N. Kuster, "Automatic E-field scanning system for dosimetric assessments", IEEE Transactions on Microwave Theory and Techniques, vol. 44, pp, 105-113, Jan. 1996.
- [4] K. Pokovi^c, T. Schmid, and N. Kuster, "Robust setup for precise calibration of E-field probes in tissue simulating liquids at mobile communications frequency", in ICECOM'97, Dubrovnik, October 15-17, 1997, pp.120-124.
- [5] K. Pokovi^c, T. Schmid, and N. Kuster, "E-field probe with improved isotropy in brain simulating liquids", in Proceedings of the ELMAR, Zadar, Croatia, 23-25 June, 1996, pp.172-175.
- [6] N. Kuster, and Q. Balzano, "Energy absorption mechanism by biological bodies in the near field of dipole antennas above 300MHz", IEEE Transaction on Vehicular Technology, vol. 41, no. 1, Feb. 1992, pp. 17-23.
- [7] Robert J. Renka, "Multivariate Interpolation Of Large Sets Of Scattered Data", University of North Texas ACM Transactions on Mathematical Software, vol. 14, no. 2, June 1988 , pp. 139-148.
- [8] N. Kuster, R. Kastle, T. Schmid, Dosimetric evaluation of mobile communications equipment with known precision, IEEE Transaction on Communications, vol. E80-B, no. 5, May 1997, pp. 645-652.
- [9] Std. C95.3-1991, "IEEE Recommended Practice for the Measurement of Potentially Hazardous Electromagnetic Fields – RF and Microwave, New York: IEEE, Aug. 1992.
- [10] CENELEC CLC/SC111B, European Prestandard (prENV 50166-2), Human Exposure to Electromagnetic Fields High-frequency: 10KHz-300GHz, Jan. 1995.
- [11] IEEE Std 1528™-2013 - IEEE Recommended Practice for Determining the Peak Spatial-Average Specific Absorption Rate (SAR) in the Human Head From Wireless Communications Devices: Measurement Techniques

Appendix A - System Performance Check

Test Laboratory: A Test Lab Techno Corp.

Date/Time: 2019/4/4 PM 12:41:14

System Performance Check at 2450MHz_20190404_Body

DUT: Dipole 2450 MHz; Type: D2450V2; Serial: D2450V2 - SN:735

Communication System: UID 0, CW (0); Frequency: 2450 MHz; Duty Cycle: 1:1

Medium parameters used: $f = 2450$ MHz; $\sigma = 2.015$ S/m; $\epsilon_r = 53.933$; $\rho = 1000$ kg/m³

Phantom section: Flat Section

Measurement Standard: DASYS (IEEE/IEC/ANSI C63.19-2007)

DASY5.2 Configuration:

- Area Scan setting - Find Secondary Maximum Within: 2.0dB and with a peak SAR value greater than 0.5 W/Kg
- Probe: EX3DV4 - SN3977; ConvF(7.56, 7.56, 7.56); Calibrated: 2018/8/30
- Sensor-Surface: 1.4mm (Mechanical Surface Detection)
- Electronics: DAE4 Sn779; Calibrated: 2018/8/14
- Phantom: ELI V5.0 (20deg probe tilt); Type: QD OVA 002 AA; Serial: 1133
- Measurement SW: DASYS2, Version 52.10 (2); SEMCAD X Version 14.6.10 (7331)

Area Scan (81x81x1): Interpolated grid: dx=1.200 mm, dy=1.200 mm

Maximum value of SAR (interpolated) = 21.5 W/kg

Zoom Scan (7x7x7)/Cube 0: Measurement grid: dx=5mm, dy=5mm, dz=5mm

Reference Value = 106.2 V/m; Power Drift = 0.04 dB

Peak SAR (extrapolated) = 27.4 W/kg

SAR(1 g) = 13 W/kg; SAR(10 g) = 5.95 W/kg

Maximum value of SAR (measured) = 22.0 W/kg

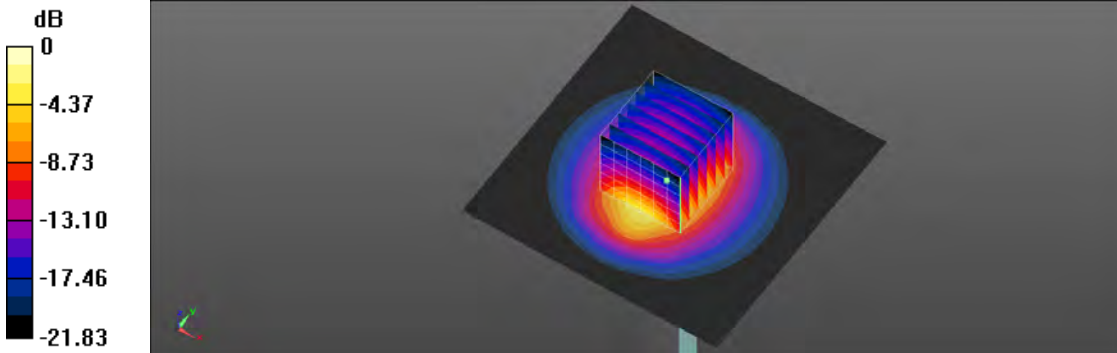

0 dB = 21.9 W/kg = 13.27 dBW/kg



Test Laboratory: A Test Lab Techno Corp.

Date/Time: 2019/4/5 PM 04:33:38

System Performance Check at 5250MHz_20190405_Body

DUT: Dipole 5GHzV2; Type: D5GHz; Serial: 1203

Communication System: UID 0, CW (0); Frequency: 5250 MHz;Duty Cycle: 1:1

Medium parameters used (interpolated): $f = 5250$ MHz; $\sigma = 5.287$ S/m; $\epsilon_r = 50.197$; $\rho = 1000$ kg/m³

Phantom section: Flat Section

Measurement Standard: DASYS5 (IEEE/IEC/ANSI C63.19-2007)

DASY5.2 Configuration:

- Area Scan setting - Find Secondary Maximum Within:2.0dB and with a peak SAR value greater than 0.5 W/Kg
- Probe: EX3DV4 - SN3977; ConvF(5.08, 5.08, 5.08); Calibrated: 2018/8/30
- Sensor-Surface: 1.4mm (Mechanical Surface Detection)
- Electronics: DAE4 Sn779; Calibrated: 2018/8/14
- Phantom: ELI V5.0 (20deg probe tilt); Type: QD OVA 002 AA; Serial: 1133
- Measurement SW: DASYS52, Version 52.10 (2); SEMCAD X Version 14.6.10 (7331)

Area Scan (91x91x1): Interpolated grid: dx=1.000 mm, dy=1.000 mm

Maximum value of SAR (interpolated) = 15.0 W/kg

Zoom Scan (7x7x7)/Cube 0: Measurement grid: dx=4mm, dy=4mm, dz=1.4mm

Reference Value = 60.41 V/m; Power Drift = -0.07 dB

Peak SAR (extrapolated) = 26.5 W/kg

SAR(1 g) = 7.34 W/kg; SAR(10 g) = 2.08 W/kg

Maximum value of SAR (measured) = 15.7 W/kg

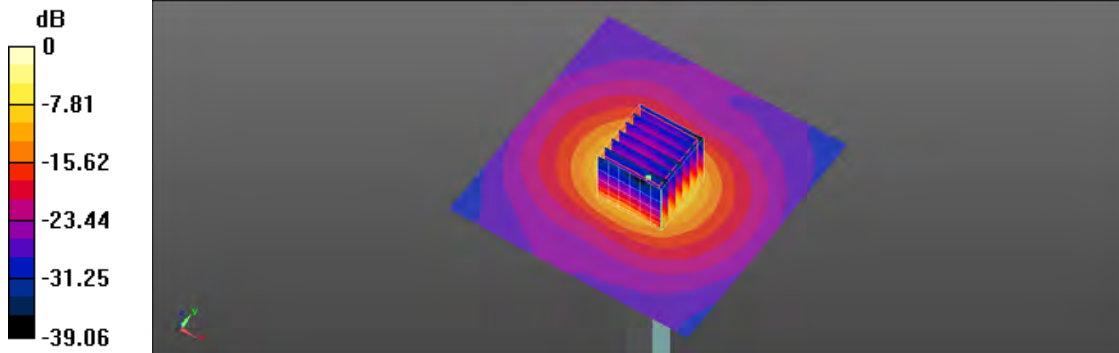

0 dB = 15.7 W/kg = 11.96 dBW/kg

Test Laboratory: A Test Lab Techno Corp.

Date/Time: 2019/4/5 PM 05:02:31

System Performance Check at 5600MHz_20190405_Body

DUT: Dipole 5GHzV2; Type: D5GHz; Serial: 1203

Communication System: UID 0, CW (0); Frequency: 5600 MHz; Duty Cycle: 1:1

Medium parameters used: $f = 5600 \text{ MHz}$; $\sigma = 5.814 \text{ S/m}$; $\epsilon_r = 49.308$; $\rho = 1000 \text{ kg/m}^3$

Phantom section: Flat Section

Measurement Standard: DASY5 (IEEE/IEC/ANSI C63.19-2007)

DASY5.2 Configuration:

- Area Scan setting - Find Secondary Maximum Within: 2.0dB and with a peak SAR value greater than 0.5 W/Kg
- Probe: EX3DV4 - SN3977; ConvF(4.41, 4.41, 4.41); Calibrated: 2018/8/30
- Sensor-Surface: 1.4mm (Mechanical Surface Detection)
- Electronics: DAE4 Sn779; Calibrated: 2018/8/14
- Phantom: ELI V5.0 (20deg probe tilt); Type: QD OVA 002 AA; Serial: 1133
- Measurement SW: DASY52, Version 52.10 (2); SEMCAD X Version 14.6.10 (7331)

Area Scan (91x91x1): Interpolated grid: $dx=1.000 \text{ mm}$, $dy=1.000 \text{ mm}$

Maximum value of SAR (interpolated) = 15.8 W/kg

Zoom Scan (7x7x7)/Cube 0: Measurement grid: $dx=4\text{mm}$, $dy=4\text{mm}$, $dz=1.4\text{mm}$

Reference Value = 59.67 V/m; Power Drift = -0.06 dB

Peak SAR (extrapolated) = 30.5 W/kg

SAR(1 g) = 7.88 W/kg; SAR(10 g) = 2.19 W/kg

Maximum value of SAR (measured) = 16.6 W/kg

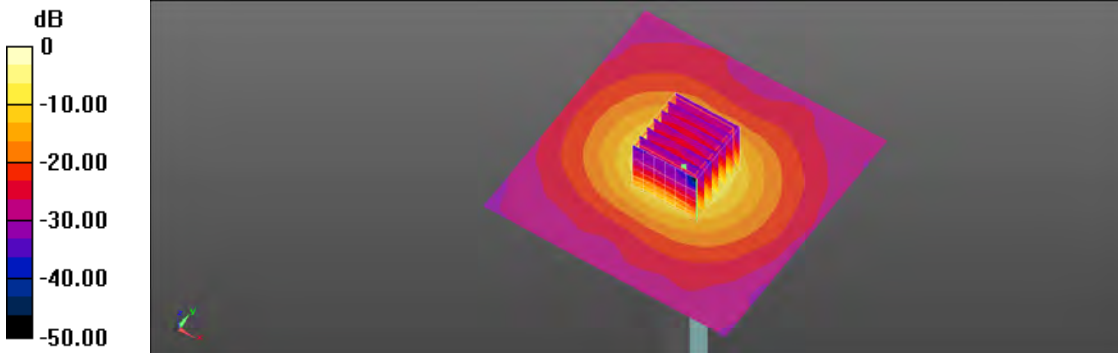

0 dB = 16.6 W/kg = 12.20 dBW/kg

Test Laboratory: A Test Lab Techno Corp.

Date/Time: 2019/4/5 PM 05:54:49

System Performance Check at 5750MHz_20190405_Body

DUT: Dipole 5GHzV2; Type: D5GHz; Serial: 1203

Communication System: UID 0, CW (0); Frequency: 5750 MHz; Duty Cycle: 1:1

Medium parameters used: $f = 5750 \text{ MHz}$; $\sigma = 6.034 \text{ S/m}$; $\epsilon_r = 48.787$; $\rho = 1000 \text{ kg/m}^3$

Phantom section: Flat Section

Measurement Standard: DASY5 (IEEE/IEC/ANSI C63.19-2007)

DASY5.2 Configuration:

- Area Scan setting - Find Secondary Maximum Within: 2.0dB and with a peak SAR value greater than 0.5 W/Kg
- Probe: EX3DV4 - SN3977; ConvF(4.49, 4.49, 4.49); Calibrated: 2018/8/30
- Sensor-Surface: 1.4mm (Mechanical Surface Detection)
- Electronics: DAE4 Sn779; Calibrated: 2018/8/14
- Phantom: ELI V5.0 (20deg probe tilt); Type: QD OVA 002 AA; Serial: 1133
- Measurement SW: DASY52, Version 52.10 (2); SEMCAD X Version 14.6.10 (7331)

Area Scan (91x91x1): Interpolated grid: $dx=1.000 \text{ mm}$, $dy=1.000 \text{ mm}$

Maximum value of SAR (interpolated) = 15.9 W/kg

Zoom Scan (7x7x7)/Cube 0: Measurement grid: $dx=4\text{mm}$, $dy=4\text{mm}$, $dz=1.4\text{mm}$

Reference Value = 58.44 V/m; Power Drift = 0.06 dB

Peak SAR (extrapolated) = 30.3 W/kg

SAR(1 g) = 7.62 W/kg; SAR(10 g) = 2.11 W/kg

Maximum value of SAR (measured) = 16.4 W/kg

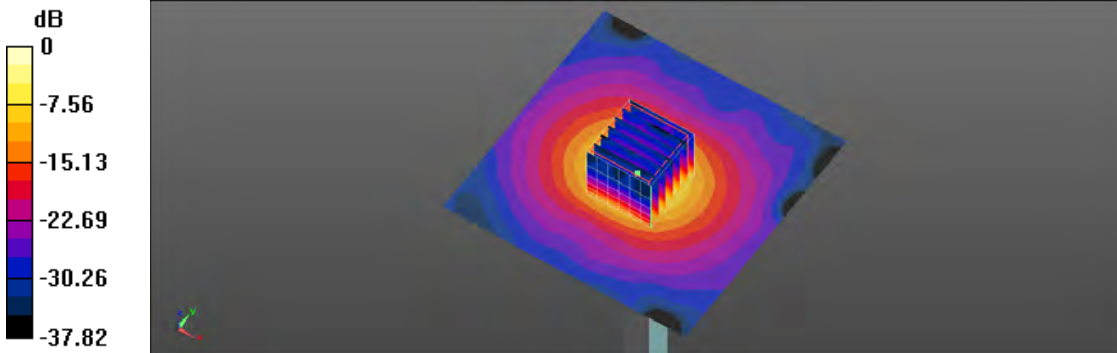

0 dB = 16.4 W/kg = 12.15 dBW/kg

Appendix B - SAR Measurement Data

Test Laboratory: A Test Lab Techno Corp.

Date/Time: 2019/4/4 PM 02:25:45

1_IEEE 802.11b CH6_1M_Bottom of Laptop_0mm_Ant Main

DUT: 9560NGW; Type: Intel Wireless-AC 9560

Communication System: UID 0, IEEE 802.11b (0); Frequency: 2437 MHz; Duty Cycle: 1:1

Medium parameters used (interpolated): $f = 2437$ MHz; $\sigma = 1.999$ S/m; $\epsilon_r = 53.986$; $\rho = 1000$ kg/m³

Phantom section: Flat Section

Measurement Standard: DASYS (IEEE/IEC/ANSI C63.19-2007)

DASY5.2 Configuration:

- Area Scan setting - Find Secondary Maximum Within: 2.0dB and with a peak SAR value greater than 0.5 W/Kg
- Probe: EX3DV4 - SN3977; ConvF(7.56, 7.56, 7.56); Calibrated: 2018/8/30;
- Sensor-Surface: 1.4mm (Mechanical Surface Detection)
- Electronics: DAE4 Sn779; Calibrated: 2018/8/14
- Phantom: ELI V5.0 (20deg probe tilt); Type: QD OVA 002 AA; Serial: 1133
- Measurement SW: DASYS2, Version 52.10 (0); SEMCAD X Version 14.6.10 (7331)

Area Scan (91x81x1): Interpolated grid: dx=1.200 mm, dy=1.200 mm

Maximum value of SAR (interpolated) = 1.75 W/kg

Zoom Scan (7x7x7)/Cube 0: Measurement grid: dx=5mm, dy=5mm, dz=5mm

Reference Value = 29.1 V/m; Power Drift = 0.04 dB

Peak SAR (extrapolated) = 2.35 W/kg

SAR(1 g) = 0.943 W/kg; SAR(10 g) = 0.356 W/kg

Maximum value of SAR (measured) = 1.81 W/kg

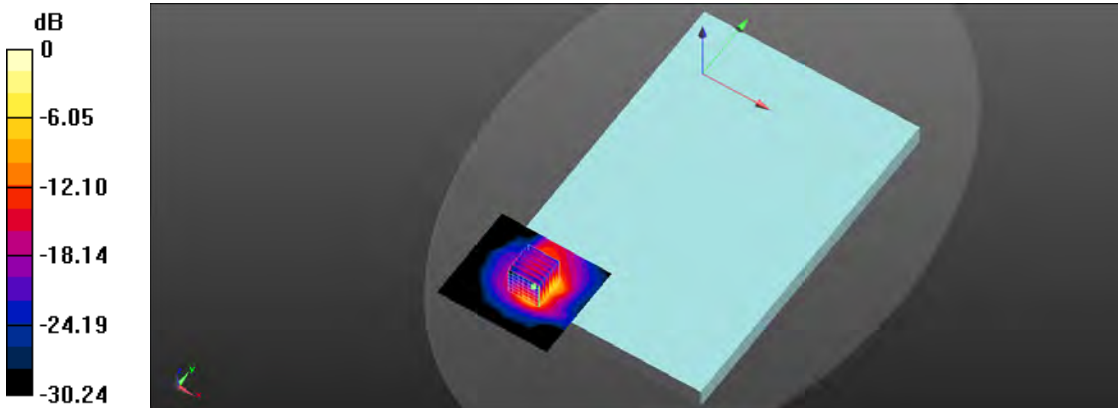

0 dB = 1.81 W/kg = 2.58 dBW/kg

Test Laboratory: A Test Lab Techno Corp.
 Date/Time: 2019/4/4 PM 02:47:05
 3_ IEEE 802.11b CH1_1M_Bottom of Laptop_0mm_Ant Main
DUT: 9560NGW; Type: Intel Wireless-AC 9560

Communication System: UID 0, IEEE 802.11b (0); Frequency: 2412 MHz; Duty Cycle: 1:1
 Medium parameters used (interpolated): $f = 2412$ MHz; $\sigma = 1.968$ S/m; $\epsilon_r = 54.101$; $\rho = 1000$ kg/m³
 Phantom section: Flat Section
 Measurement Standard: DASYS (IEEE/IEC/ANSI C63.19-2007)
 DASYS.2 Configuration:

- Area Scan setting - Find Secondary Maximum Within: 2.0dB and with a peak SAR value greater than 0.5 W/Kg
- Probe: EX3DV4 - SN3977; ConvF(7.56, 7.56, 7.56); Calibrated: 2018/8/30;
- Sensor-Surface: 1.4mm (Mechanical Surface Detection)
- Electronics: DAE4 Sn779; Calibrated: 2018/8/14
- Phantom: ELI V5.0 (20deg probe tilt); Type: QD OVA 002 AA; Serial: 1133
- Measurement SW: DASYS2, Version 52.10 (0); SEMCAD X Version 14.6.10 (7331)

Area Scan (91x81x1): Interpolated grid: $dx=1.200$ mm, $dy=1.200$ mm
 Maximum value of SAR (interpolated) = 1.72 W/kg

Zoom Scan (7x7x7)/Cube 0: Measurement grid: $dx=5$ mm, $dy=5$ mm, $dz=5$ mm
 Reference Value = 24.2 V/m; Power Drift = 0.04 dB
 Peak SAR (extrapolated) = 2.13 W/kg
SAR(1 g) = 0.879 W/kg; SAR(10 g) = 0.329 W/kg
 Maximum value of SAR (measured) = 1.71 W/kg

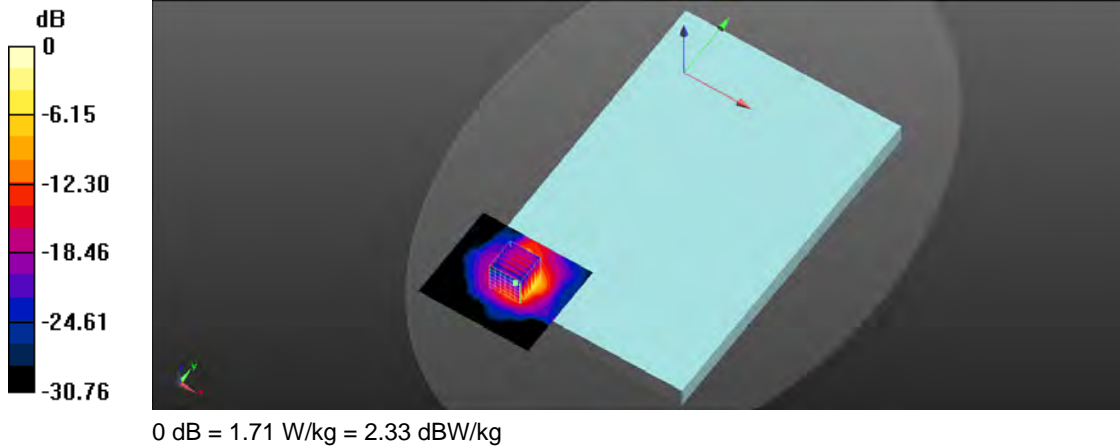

Test Laboratory: A Test Lab Techno Corp.
 Date/Time: 2019/4/4 PM 03:07:38
 4_IEEE 802.11b CH11_1M_Bottom of Laptop_0mm_Ant Main
DUT: 9560NGW; Type: Intel Wireless-AC 9560

Communication System: UID 0, IEEE 802.11b (0); Frequency: 2462 MHz; Duty Cycle: 1:1
 Medium parameters used (interpolated): $f = 2462$ MHz; $\sigma = 2.031$ S/m; $\epsilon_r = 53.892$; $\rho = 1000$ kg/m³
 Phantom section: Flat Section
 Measurement Standard: DASYS5 (IEEE/IEC/ANSI C63.19-2007)
 DASYS5.2 Configuration:

- Area Scan setting - Find Secondary Maximum Within: 2.0dB and with a peak SAR value greater than 0.5 W/Kg
- Probe: EX3DV4 - SN3977; ConvF(7.56, 7.56, 7.56); Calibrated: 2018/8/30;
- Sensor-Surface: 1.4mm (Mechanical Surface Detection)
- Electronics: DAE4 Sn779; Calibrated: 2018/8/14
- Phantom: ELI V5.0 (20deg probe tilt); Type: QD OVA 002 AA; Serial: 1133
- Measurement SW: DASYS52, Version 52.10 (0); SEMCAD X Version 14.6.10 (7331)

Area Scan (91x81x1): Interpolated grid: $dx=1.200$ mm, $dy=1.200$ mm
 Maximum value of SAR (interpolated) = 1.88 W/kg

Zoom Scan (7x7x7)/Cube 0: Measurement grid: $dx=5$ mm, $dy=5$ mm, $dz=5$ mm
 Reference Value = 28.02 V/m; Power Drift = 0.03 dB
 Peak SAR (extrapolated) = 2.54 W/kg
SAR(1 g) = 1.03 W/kg; SAR(10 g) = 0.382 W/kg
 Maximum value of SAR (measured) = 1.84 W/kg

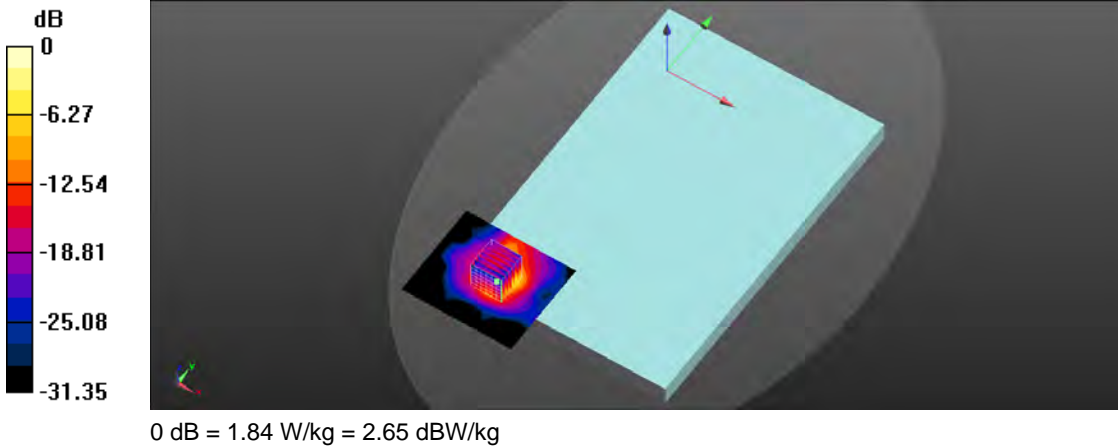

Test Laboratory: A Test Lab Techno Corp.

Date/Time: 2019/4/4 06:22:15 PM

18_IEEE 802.11b CH11_1M_Bottom of Laptop_0mm_Ant Main;repeat

DUT: 9560NGW; Type: Intel Wireless-AC 9560

Communication System: UID 0, IEEE 802.11b (0); Frequency: 2462 MHz;Duty Cycle: 1:1

Medium parameters used (interpolated): $f = 2462$ MHz; $\sigma = 2.031$ S/m; $\epsilon_r = 53.892$; $\rho = 1000$ kg/m³

Phantom section: Flat Section

Measurement Standard: DASYS5 (IEEE/IEC/ANSI C63.19-2007)

DASY5.2 Configuration:

- Area Scan setting - Find Secondary Maximum Within:2.0dB and with a peak SAR value greater than 0.5 W/Kg
- Probe: EX3DV4 - SN3977; ConvF(7.56, 7.56, 7.56); Calibrated: 2018/8/30
- Sensor-Surface: 1.4mm (Mechanical Surface Detection)
- Electronics: DAE4 Sn779; Calibrated: 2018/8/14
- Phantom: ELI V5.0 (20deg probe tilt); Type: QD OVA 002 AA; Serial: 1133
- Measurement SW: DASYS2, Version 52.10 (2); SEMCAD X Version 14.6.10 (7331)

Area Scan (91x81x1): Interpolated grid: dx=1.200 mm, dy=1.200 mm

Maximum value of SAR (interpolated) = 1.79 W/kg

Zoom Scan (7x7x7)/Cube 0: Measurement grid: dx=5mm, dy=5mm, dz=5mm

Reference Value = 29.22 V/m; Power Drift = 0.04 dB

Peak SAR (extrapolated) = 2.40 W/kg

SAR(1 g) = 0.965 W/kg; SAR(10 g) = 0.365 W/kg

Maximum value of SAR (measured) = 1.86 W/kg

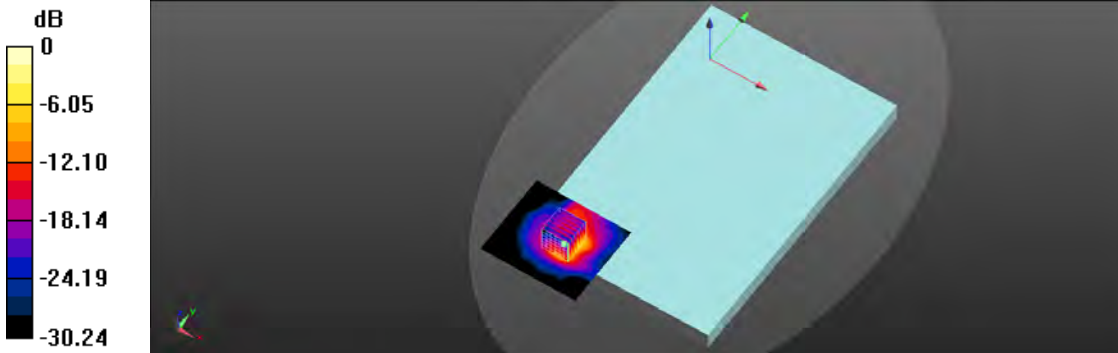

0 dB = 1.86 W/kg = 2.70 dBW/kg



Test Laboratory: A Test Lab Techno Corp.
Date/Time: 2019/4/4 PM 01:17:43
2_ IEEE 802.11b CH6_1M_Bottom of Laptop_0mm_Ant Aux
DUT: 9560NGW; Type: Intel Wireless-AC 9560

Communication System: UID 0, IEEE 802.11b (0); Frequency: 2437 MHz; Duty Cycle: 1:1
Medium parameters used (interpolated): $f = 2437$ MHz; $\sigma = 1.999$ S/m; $\epsilon_r = 53.986$; $\rho = 1000$ kg/m³
Phantom section: Flat Section
Measurement Standard: DASYS5 (IEEE/IEC/ANSI C63.19-2007)
DASY5.2 Configuration:

- Area Scan setting - Find Secondary Maximum Within: 2.0dB and with a peak SAR value greater than 0.5 W/Kg
- Probe: EX3DV4 - SN3977; ConvF(7.56, 7.56, 7.56); Calibrated: 2018/8/30;
- Sensor-Surface: 1.4mm (Mechanical Surface Detection)
- Electronics: DAE4 Sn779; Calibrated: 2018/8/14
- Phantom: ELI V5.0 (20deg probe tilt); Type: QD OVA 002 AA; Serial: 1133
- Measurement SW: DASYS52, Version 52.10 (0); SEMCAD X Version 14.6.10 (7331)

Area Scan (101x81x1): Interpolated grid: dx=1.200 mm, dy=1.200 mm
Maximum value of SAR (interpolated) = 0.593 W/kg

Zoom Scan (7x7x7)/Cube 0: Measurement grid: dx=5mm, dy=5mm, dz=5mm
Reference Value = 15.44 V/m; Power Drift = -0.15 dB
Peak SAR (extrapolated) = 0.866 W/kg
SAR(1 g) = 0.383 W/kg; SAR(10 g) = 0.172 W/kg
Maximum value of SAR (measured) = 0.673 W/kg

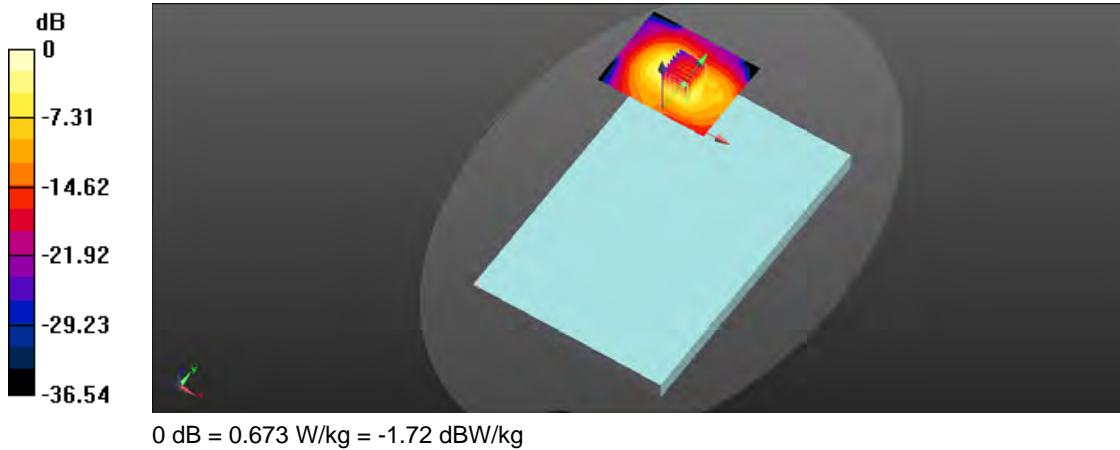

Test Laboratory: A Test Lab Techno Corp.
 Date/Time: 2019/4/5 PM 06:04:06
 5_ IEEE 802.11ac 80 CH58_MCS0_Bottom of laptop_0mm_Ant Main
DUT: 9560NGW; Type: Intel Wireless-AC 9560

Communication System: UID 0, IEEE 802.11ac (0); Frequency: 5290 MHz; Duty Cycle: 1:1
 Medium parameters used (interpolated): $f = 5290$ MHz; $\sigma = 5.315$ S/m; $\epsilon_r = 50.016$; $\rho = 1000$ kg/m³
 Phantom section: Flat Section
 Measurement Standard: DASYS (IEEE/IEC/ANSI C63.19-2007)
 DASYS5.2 Configuration:

- Area Scan setting - Find Secondary Maximum Within: 2.0dB and with a peak SAR value greater than 0.5 W/Kg
- Probe: EX3DV4 - SN3977; ConvF(5.08, 5.08, 5.08); Calibrated: 2018/8/30;
- Sensor-Surface: 1.4mm (Mechanical Surface Detection)
- Electronics: DAE4 Sn779; Calibrated: 2018/8/14
- Phantom: ELI V5.0 (20deg probe tilt); Type: QD OVA 002 AA; Serial: 1133
- Measurement SW: DASYS2, Version 52.10 (0); SEMCAD X Version 14.6.10 (7331)

Area Scan (111x91x1): Interpolated grid: dx=1.000 mm, dy=1.000 mm
 Maximum value of SAR (interpolated) = 2.33 W/kg

Zoom Scan (7x7x7)/Cube 0: Measurement grid: dx=4mm, dy=4mm, dz=1.4mm
 Reference Value = 31.14 V/m; Power Drift = 0.04 dB
 Peak SAR (extrapolated) = 4.78 W/kg

SAR(1 g) = 0.914 W/kg; SAR(10 g) = 0.236 W/kg
 Maximum value of SAR (measured) = 2.19 W/kg

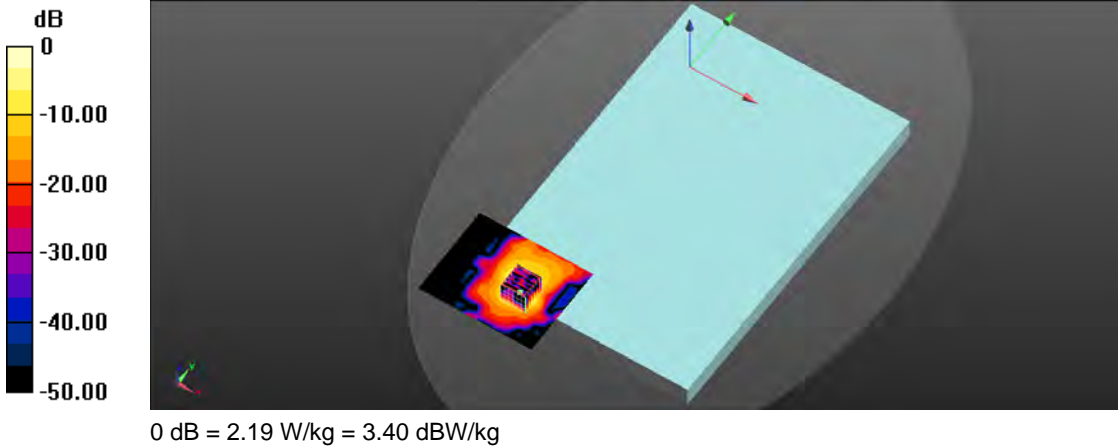

Test Laboratory: A Test Lab Techno Corp.

Date/Time: 2019/4/5 11:44:16 PM

19_IEEE 802.11ac 80 CH58_MCS0_Bottom of laptop_0mm_Ant Main;repeat

DUT: 9560NGW; Type: Intel Wireless-AC 9560

Communication System: UID 0, IEEE 802.11ac (0); Frequency: 5290 MHz;Duty Cycle: 1:1

Medium parameters used (interpolated): $f = 5290$ MHz; $\sigma = 5.315$ S/m; $\epsilon_r = 50.016$; $\rho = 1000$ kg/m³

Phantom section: Flat Section

Measurement Standard: DASYS (IEEE/IEC/ANSI C63.19-2007)

DASY5.2 Configuration:

- Area Scan setting - Find Secondary Maximum Within:2.0dB and with a peak SAR value greater than 0.5 W/Kg
- Probe: EX3DV4 - SN3977; ConvF(5.08, 5.08, 5.08); Calibrated: 2018/8/30
- Sensor-Surface: 1.4mm (Mechanical Surface Detection)
- Electronics: DAE4 Sn779; Calibrated: 2018/8/14
- Phantom: ELI V5.0 (20deg probe tilt); Type: QD OVA 002 AA; Serial: 1133
- Measurement SW: DASYS2, Version 52.10 (2); SEMCAD X Version 14.6.10 (7331)

Area Scan (111x91x1): Interpolated grid: dx=1.000 mm, dy=1.000 mm

Maximum value of SAR (interpolated) = 2.31 W/kg

Zoom Scan (7x7x7)/Cube 0: Measurement grid: dx=4mm, dy=4mm, dz=1.4mm

Reference Value = 30.69 V/m; Power Drift = 0.04 dB

Peak SAR (extrapolated) = 4.71 W/kg

SAR(1 g) = 0.901 W/kg; SAR(10 g) = 0.233 W/kg

Maximum value of SAR (measured) = 2.19 W/kg

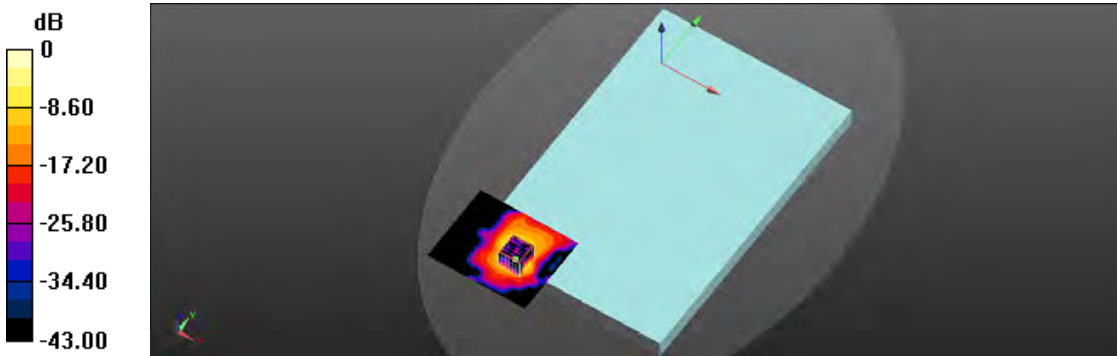

0 dB = 2.16 W/kg = 3.34 dBW/kg

Test Laboratory: A Test Lab Techno Corp.
 Date/Time: 2019/4/5 PM 08:03:41
 7_ IEEE 802.11ac 80 CH106_MCS0_Bottom of laptop_0mm_Ant Main
DUT: 9560NGW; Type: Intel Wireless-AC 9560

Communication System: UID 0, IEEE 802.11ac (0); Frequency: 5530 MHz; Duty Cycle: 1:1
 Medium parameters used (interpolated): $f = 5530$ MHz; $\sigma = 5.692$ S/m; $\epsilon_r = 49.362$; $\rho = 1000$ kg/m³
 Phantom section: Flat Section
 Measurement Standard: DASYS5 (IEEE/IEC/ANSI C63.19-2007)

DASY5.2 Configuration:

- Area Scan setting - Find Secondary Maximum Within: 2.0dB and with a peak SAR value greater than 0.5 W/Kg
- Probe: EX3DV4 - SN3977; ConvF(4.41, 4.41, 4.41); Calibrated: 2018/8/30;
- Sensor-Surface: 1.4mm (Mechanical Surface Detection)
- Electronics: DAE4 Sn779; Calibrated: 2018/8/14
- Phantom: ELI V5.0 (20deg probe tilt); Type: QD OVA 002 AA; Serial: 1133
- Measurement SW: DASYS52, Version 52.10 (0); SEMCAD X Version 14.6.10 (7331)

Area Scan (111x91x1): Interpolated grid: dx=1.000 mm, dy=1.000 mm
 Maximum value of SAR (interpolated) = 1.70 W/kg

Zoom Scan (7x7x7)/Cube 0: Measurement grid: dx=4mm, dy=4mm, dz=1.4mm
 Reference Value = 35.54 V/m; Power Drift = 0.03 dB
 Peak SAR (extrapolated) = 2.91 W/kg

SAR(1 g) = 0.666 W/kg; SAR(10 g) = 0.184 W/kg
 Maximum value of SAR (measured) = 1.60 W/kg

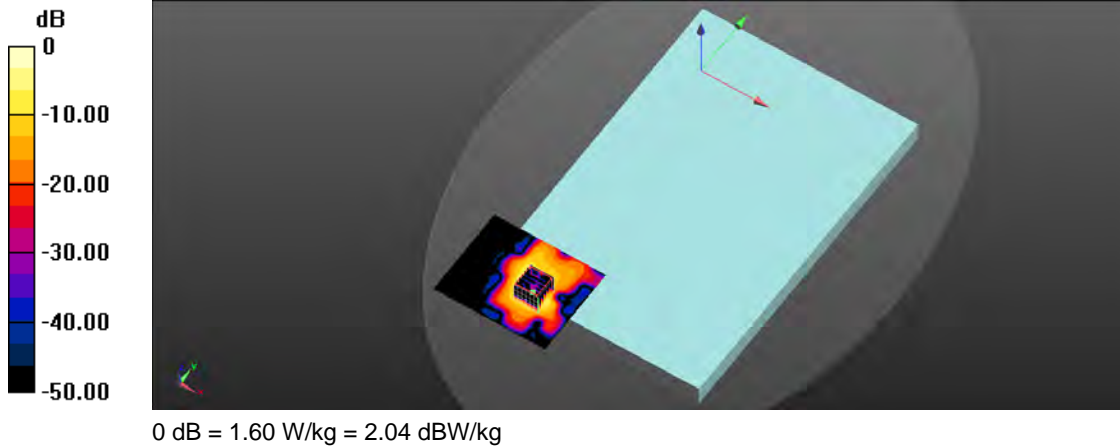

Test Laboratory: A Test Lab Techno Corp.
 Date/Time: 2019/4/5 PM 08:51:22
 9_IEEE 802.11ac 80 CH122_MCS0_Bottom of laptop_0mm_Ant Main
DUT: 9560NGW; Type: Intel Wireless-AC 9560

Communication System: UID 0, IEEE 802.11ac (0); Frequency: 5610 MHz; Duty Cycle: 1:1
 Medium parameters used (interpolated): $f = 5610$ MHz; $\sigma = 5.819$ S/m; $\epsilon_r = 49.285$; $\rho = 1000$ kg/m³
 Phantom section: Flat Section
 Measurement Standard: DASY5 (IEEE/IEC/ANSI C63.19-2007)
 DASY5.2 Configuration:

- Area Scan setting - Find Secondary Maximum Within: 2.0dB and with a peak SAR value greater than 0.5 W/Kg
- Probe: EX3DV4 - SN3977; ConvF(4.41, 4.41, 4.41); Calibrated: 2018/8/30;
- Sensor-Surface: 1.4mm (Mechanical Surface Detection)
- Electronics: DAE4 Sn779; Calibrated: 2018/8/14
- Phantom: ELI V5.0 (20deg probe tilt); Type: QD OVA 002 AA; Serial: 1133
- Measurement SW: DASY52, Version 52.10 (0); SEMCAD X Version 14.6.10 (7331)

Area Scan (111x91x1): Interpolated grid: dx=1.000 mm, dy=1.000 mm
 Maximum value of SAR (interpolated) = 1.47 W/kg

Zoom Scan (7x7x7)/Cube 0: Measurement grid: dx=4mm, dy=4mm, dz=1.4mm
 Reference Value = 37.57 V/m; Power Drift = 0.02 dB
 Peak SAR (extrapolated) = 2.55 W/kg

SAR(1 g) = 0.568 W/kg; SAR(10 g) = 0.166 W/kg
 Maximum value of SAR (measured) = 1.44 W/kg

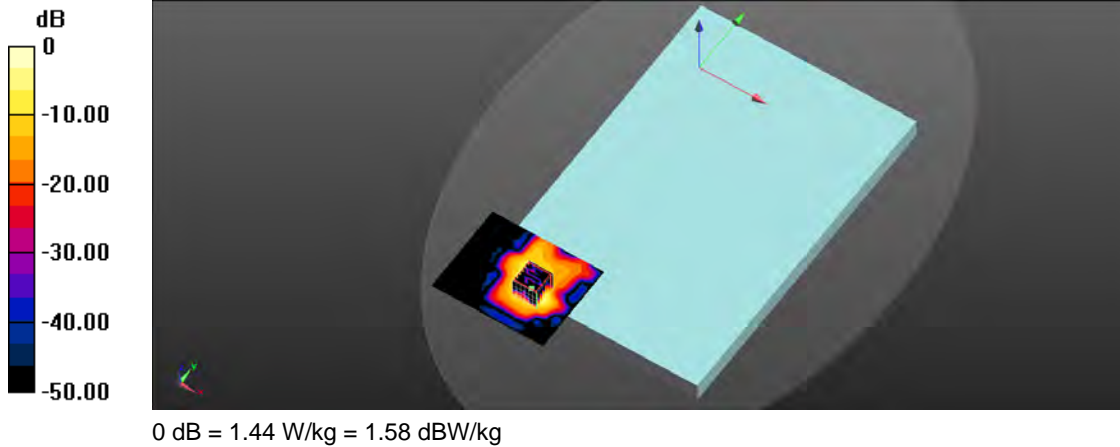

Test Laboratory: A Test Lab Techno Corp.
 Date/Time: 2019/4/5 PM 09:13:12
 11_IEEE 802.11ac 80 CH138_MCS0_Bottom of laptop_0mm_Ant Main
DUT: 9560NGW; Type: Intel Wireless-AC 9560

Communication System: UID 0, IEEE 802.11ac (0); Frequency: 5690 MHz;Duty Cycle: 1:1
 Medium parameters used (interpolated): $f = 5690$ MHz; $\sigma = 5.976$ S/m; $\epsilon_r = 48.919$; $\rho = 1000$ kg/m³
 Phantom section: Flat Section
 Measurement Standard: DASY5 (IEEE/IEC/ANSI C63.19-2007)
 DASY5.2 Configuration:

- Area Scan setting - Find Secondary Maximum Within:2.0dB and with a peak SAR value greater than 0.5 W/Kg
- Probe: EX3DV4 - SN3977; ConvF(4.41, 4.41, 4.41); Calibrated: 2018/8/30;
- Sensor-Surface: 1.4mm (Mechanical Surface Detection)
- Electronics: DAE4 Sn779; Calibrated: 2018/8/14
- Phantom: ELI V5.0 (20deg probe tilt); Type: QD OVA 002 AA; Serial: 1133
- Measurement SW: DASY52, Version 52.10 (0); SEMCAD X Version 14.6.10 (7331)

Area Scan (111x91x1): Interpolated grid: dx=1.000 mm, dy=1.000 mm
 Maximum value of SAR (interpolated) = 1.40 W/kg

Zoom Scan (7x7x7)/Cube 0: Measurement grid: dx=4mm, dy=4mm, dz=1.4mm
 Reference Value = 37.71 V/m; Power Drift = 0.04 dB
 Peak SAR (extrapolated) = 2.36 W/kg

SAR(1 g) = 0.519 W/kg; SAR(10 g) = 0.155 W/kg
 Maximum value of SAR (measured) = 1.30 W/kg

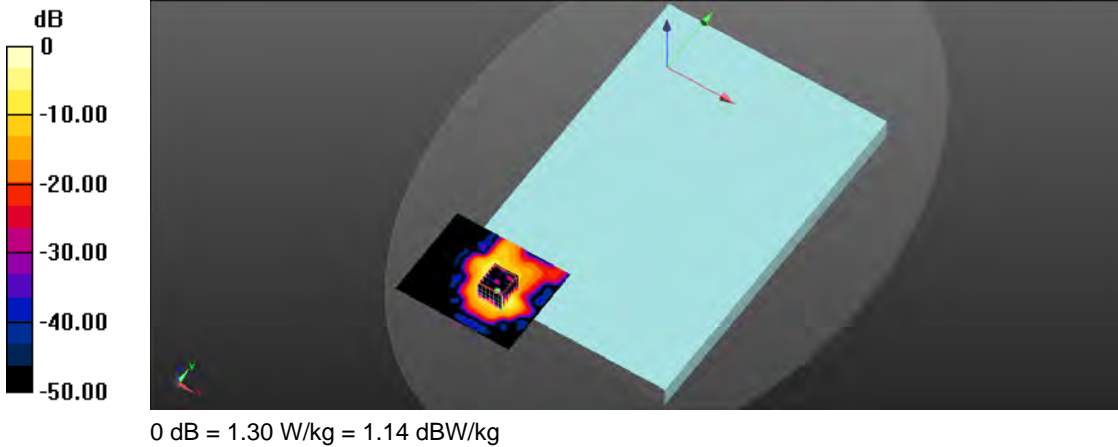

Test Laboratory: A Test Lab Techno Corp.
 Date/Time: 2019/4/5 PM 10:09:50
 13_IEEE 802.11ac 80 CH155_MCS0_Bottom of laptop_0mm_ant Main
DUT: 9560NGW; Type: Intel Wireless-AC 9560

Communication System: UID 0, IEEE 802.11ac (0); Frequency: 5775 MHz; Duty Cycle: 1:1
 Medium parameters used: $f = 5775 \text{ MHz}$; $\sigma = 6.099 \text{ S/m}$; $\epsilon_r = 48.587$; $\rho = 1000 \text{ kg/m}^3$
 Phantom section: Flat Section
 Measurement Standard: DASYS (IEEE/IEC/ANSI C63.19-2007)

DASY5.2 Configuration:

- Area Scan setting - Find Secondary Maximum Within: 2.0dB and with a peak SAR value greater than 0.5 W/Kg
- Probe: EX3DV4 - SN3977; ConvF(4.49, 4.49, 4.49); Calibrated: 2018/8/30;
- Sensor-Surface: 1.4mm (Mechanical Surface Detection)
- Electronics: DAE4 Sn779; Calibrated: 2018/8/14
- Phantom: ELI V5.0 (20deg probe tilt); Type: QD OVA 002 AA; Serial: 1133
- Measurement SW: DASYS2, Version 52.10 (0); SEMCAD X Version 14.6.10 (7331)

Area Scan (111x91x1): Interpolated grid: $dx=1.000 \text{ mm}$, $dy=1.000 \text{ mm}$
 Maximum value of SAR (interpolated) = 1.41 W/kg

Zoom Scan (7x7x7)/Cube 0: Measurement grid: $dx=4\text{mm}$, $dy=4\text{mm}$, $dz=1.4\text{mm}$
 Reference Value = 38.1 V/m; Power Drift = -0.01 dB
 Peak SAR (extrapolated) = 2.07 W/kg

SAR(1 g) = 0.429 W/kg; SAR(10 g) = 0.130 W/kg
 Maximum value of SAR (measured) = 1.15 W/kg

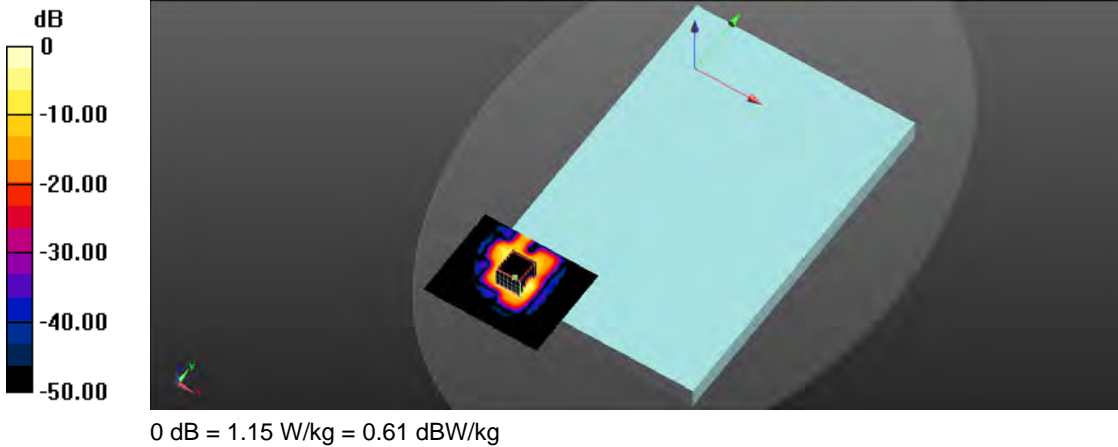

Test Laboratory: A Test Lab Techno Corp.
 Date/Time: 2019/4/5 PM 07:00:11
 6_ IEEE 802.11ac 80 CH58_MCS0_Bottom of laptop_0mm_Ant Aux
DUT: 9560NGW; Type: Intel Wireless-AC 9560

Communication System: UID 0, IEEE 802.11ac (0); Frequency: 5290 MHz; Duty Cycle: 1:1
 Medium parameters used (interpolated): $f = 5290 \text{ MHz}$; $\sigma = 5.315 \text{ S/m}$; $\epsilon_r = 50.016$; $\rho = 1000 \text{ kg/m}^3$
 Phantom section: Flat Section
 Measurement Standard: DASYS (IEEE/IEC/ANSI C63.19-2007)
 DASYS.2 Configuration:

- Area Scan setting - Find Secondary Maximum Within: 2.0dB and with a peak SAR value greater than 0.5 W/Kg
- Probe: EX3DV4 - SN3977; ConvF(5.08, 5.08, 5.08); Calibrated: 2018/8/30;
- Sensor-Surface: 1.4mm (Mechanical Surface Detection)
- Electronics: DAE4 Sn779; Calibrated: 2018/8/14
- Phantom: ELI V5.0 (20deg probe tilt); Type: QD OVA 002 AA; Serial: 1133
- Measurement SW: DASYS2, Version 52.10 (0); SEMCAD X Version 14.6.10 (7331)

Area Scan (121x91x1): Interpolated grid: $dx=1.000 \text{ mm}$, $dy=1.000 \text{ mm}$
 Maximum value of SAR (interpolated) = 2.55 W/kg

Zoom Scan (7x7x7)/Cube 0: Measurement grid: $dx=4\text{mm}$, $dy=4\text{mm}$, $dz=1.4\text{mm}$
 Reference Value = 33.44 V/m; Power Drift = -0.10 dB
 Peak SAR (extrapolated) = 3.86 W/kg
SAR(1 g) = 0.901 W/kg; SAR(10 g) = 0.240 W/kg
 Maximum value of SAR (measured) = 2.23 W/kg

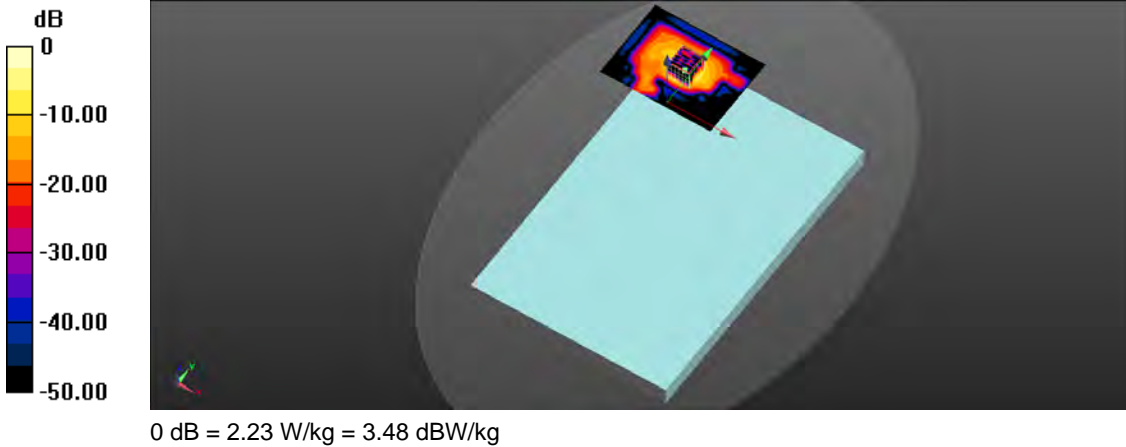

Test Laboratory: A Test Lab Techno Corp.

Date/Time: 2019/4/5 PM 07:40:18

8_ IEEE 802.11ac 80 CH106_MCS0_Bottom of laptop_0mm_Ant Aux

DUT: 9560NGW; Type: Intel Wireless-AC 9560

Communication System: UID 0, IEEE 802.11ac (0); Frequency: 5530 MHz; Duty Cycle: 1:1

Medium parameters used (interpolated): $f = 5530$ MHz; $\sigma = 5.692$ S/m; $\epsilon_r = 49.362$; $\rho = 1000$ kg/m³

Phantom section: Flat Section

Measurement Standard: DASYS (IEEE/IEC/ANSI C63.19-2007)

DASY5.2 Configuration:

- Area Scan setting - Find Secondary Maximum Within: 2.0dB and with a peak SAR value greater than 0.5 W/Kg
- Probe: EX3DV4 - SN3977; ConvF(4.41, 4.41, 4.41); Calibrated: 2018/8/30;
- Sensor-Surface: 1.4mm (Mechanical Surface Detection)
- Electronics: DAE4 Sn779; Calibrated: 2018/8/14
- Phantom: ELI V5.0 (20deg probe tilt); Type: QD OVA 002 AA; Serial: 1133
- Measurement SW: DASYS2, Version 52.10 (0); SEMCAD X Version 14.6.10 (7331)

Area Scan (121x91x1): Interpolated grid: dx=1.000 mm, dy=1.000 mm

Maximum value of SAR (interpolated) = 2.05 W/kg

Zoom Scan (7x7x7)/Cube 0: Measurement grid: dx=4mm, dy=4mm, dz=1.4mm

Reference Value = 29.75 V/m; Power Drift = -0.12 dB

Peak SAR (extrapolated) = 3.21 W/kg

SAR(1 g) = 0.719 W/kg; SAR(10 g) = 0.183 W/kg

Maximum value of SAR (measured) = 1.79 W/kg

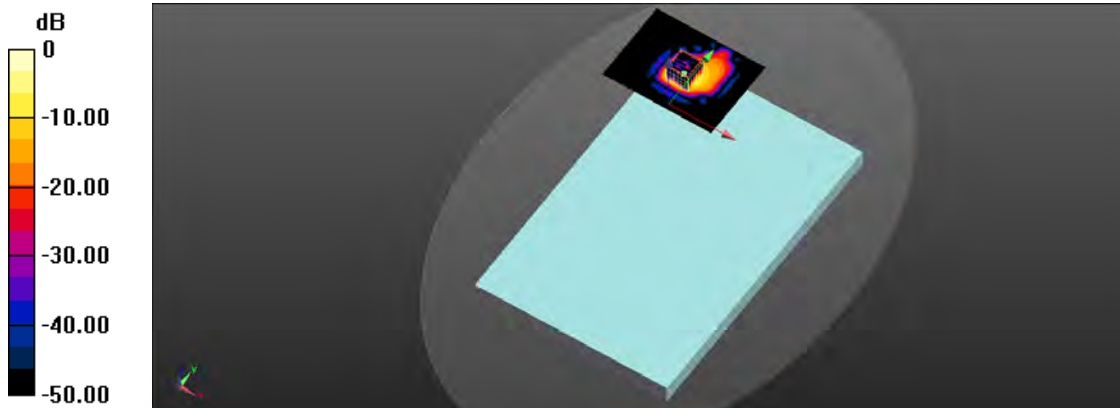

0 dB = 1.79 W/kg = 2.53 dBW/kg

Test Laboratory: A Test Lab Techno Corp.
 Date/Time: 2019/4/5 PM 08:27:22
 10_IEEE 802.11ac 80 CH122_MCS0_Bottom of laptop_0mm_Ant Aux
DUT: 9560NGW; Type: Intel Wireless-AC 9560

Communication System: UID 0, IEEE 802.11ac (0); Frequency: 5610 MHz;Duty Cycle: 1:1
 Medium parameters used (interpolated): $f = 5610$ MHz; $\sigma = 5.819$ S/m; $\epsilon_r = 49.285$; $\rho = 1000$ kg/m³
 Phantom section: Flat Section
 Measurement Standard: DASYS (IEEE/IEC/ANSI C63.19-2007)
 DASYS.2 Configuration:

- Area Scan setting - Find Secondary Maximum Within:2.0dB and with a peak SAR value greater than 0.5 W/Kg
- Probe: EX3DV4 - SN3977; ConvF(4.41, 4.41, 4.41); Calibrated: 2018/8/30;
- Sensor-Surface: 1.4mm (Mechanical Surface Detection)
- Electronics: DAE4 Sn779; Calibrated: 2018/8/14
- Phantom: ELI V5.0 (20deg probe tilt); Type: QD OVA 002 AA; Serial: 1133
- Measurement SW: DASYS2, Version 52.10 (0); SEMCAD X Version 14.6.10 (7331)

Area Scan (121x91x1): Interpolated grid: dx=1.000 mm, dy=1.000 mm
 Maximum value of SAR (interpolated) = 1.70 W/kg

Zoom Scan (7x7x7)/Cube 0: Measurement grid: dx=4mm, dy=4mm, dz=1.4mm
 Reference Value = 23.73 V/m; Power Drift = -0.14 dB
 Peak SAR (extrapolated) = 2.83 W/kg
SAR(1 g) = 0.610 W/kg; SAR(10 g) = 0.147 W/kg
 Maximum value of SAR (measured) = 1.60 W/kg

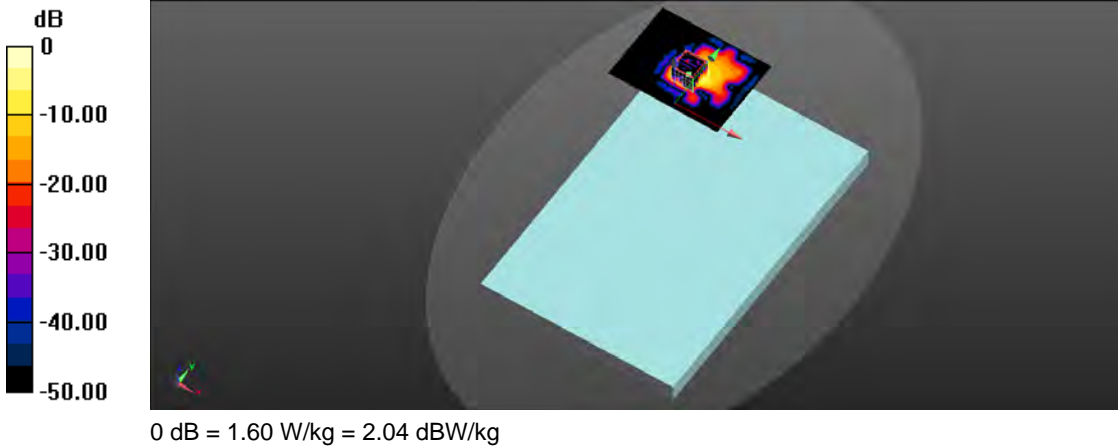

Test Laboratory: A Test Lab Techno Corp.
 Date/Time: 2019/4/5 PM 09:35:28
 12_IEEE 802.11ac 80 CH138_MCS0_Bottom of laptop_0mm_Ant Aux
DUT: 9560NGW; Type: Intel Wireless-AC 9560

Communication System: UID 0, IEEE 802.11ac (0); Frequency: 5690 MHz; Duty Cycle: 1:1
 Medium parameters used (interpolated): $f = 5690$ MHz; $\sigma = 5.976$ S/m; $\epsilon_r = 48.919$; $\rho = 1000$ kg/m³
 Phantom section: Flat Section
 Measurement Standard: DASYS (IEEE/IEC/ANSI C63.19-2007)
 DASYS.2 Configuration:

- Area Scan setting - Find Secondary Maximum Within: 2.0dB and with a peak SAR value greater than 0.5 W/Kg
- Probe: EX3DV4 - SN3977; ConvF(4.41, 4.41, 4.41); Calibrated: 2018/8/30;
- Sensor-Surface: 1.4mm (Mechanical Surface Detection)
- Electronics: DAE4 Sn779; Calibrated: 2018/8/14
- Phantom: ELI V5.0 (20deg probe tilt); Type: QD OVA 002 AA; Serial: 1133
- Measurement SW: DASYS2, Version 52.10 (0); SEMCAD X Version 14.6.10 (7331)

Area Scan (121x91x1): Interpolated grid: dx=1.000 mm, dy=1.000 mm
 Maximum value of SAR (interpolated) = 1.56 W/kg

Zoom Scan (7x7x7)/Cube 0: Measurement grid: dx=4mm, dy=4mm, dz=1.4mm
 Reference Value = 20.8 V/m; Power Drift = -0.16 dB
 Peak SAR (extrapolated) = 3.73 W/kg
SAR(1 g) = 0.550 W/kg; SAR(10 g) = 0.133 W/kg
 Maximum value of SAR (measured) = 1.56 W/kg

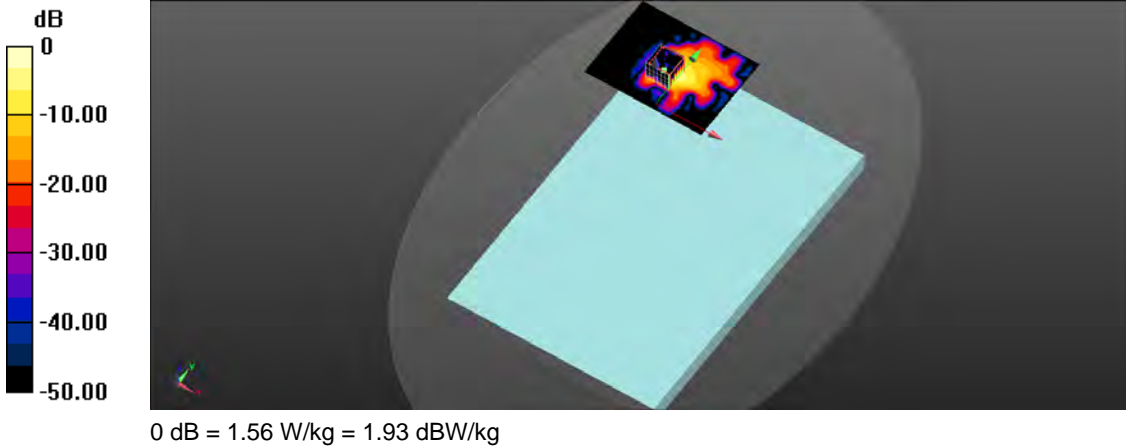

Test Laboratory: A Test Lab Techno Corp.
 Date/Time: 2019/4/5 PM 10:53:15
 14_IEEE 802.11ac 80 CH155_MCS0_Bottom of laptop_0mm_Ant Aux
DUT: 9560NGW; Type: Intel Wireless-AC 9560

Communication System: UID 0, IEEE 802.11ac (0); Frequency: 5775 MHz; Duty Cycle: 1:1
 Medium parameters used: $f = 5775 \text{ MHz}$; $\sigma = 6.099 \text{ S/m}$; $\epsilon_r = 48.587$; $\rho = 1000 \text{ kg/m}^3$
 Phantom section: Flat Section
 Measurement Standard: DASYS (IEEE/IEC/ANSI C63.19-2007)
 DASYS.2 Configuration:

- Area Scan setting - Find Secondary Maximum Within: 2.0dB and with a peak SAR value greater than 0.5 W/Kg
- Probe: EX3DV4 - SN3977; ConvF(4.49, 4.49, 4.49); Calibrated: 2018/8/30;
- Sensor-Surface: 1.4mm (Mechanical Surface Detection)
- Electronics: DAE4 Sn779; Calibrated: 2018/8/14
- Phantom: ELI V5.0 (20deg probe tilt); Type: QD OVA 002 AA; Serial: 1133
- Measurement SW: DASYS2, Version 52.10 (0); SEMCAD X Version 14.6.10 (7331)

Area Scan (121x91x1): Interpolated grid: $dx=1.000 \text{ mm}$, $dy=1.000 \text{ mm}$
 Maximum value of SAR (interpolated) = 1.84 W/kg

Zoom Scan (7x7x7)/Cube 0: Measurement grid: $dx=4\text{mm}$, $dy=4\text{mm}$, $dz=1.4\text{mm}$
 Reference Value = 33.67 V/m; Power Drift = -0.12 dB
 Peak SAR (extrapolated) = 2.52 W/kg
SAR(1 g) = 0.493 W/kg; SAR(10 g) = 0.117 W/kg
 Maximum value of SAR (measured) = 1.40 W/kg

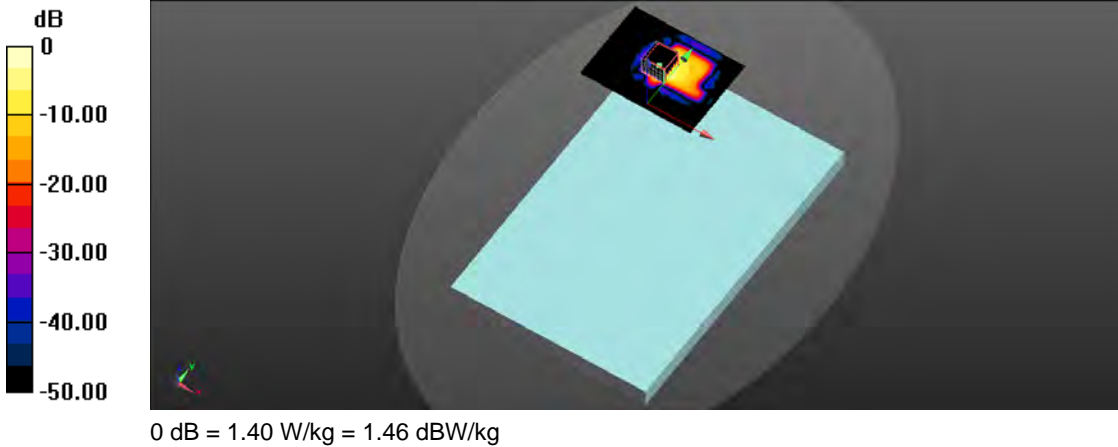

Test Laboratory: A Test Lab Techno Corp.
 Date/Time: 2019/4/4 PM 05:16:24
 15_Bluetooth CH0_1M_Bottom of laptop_0mm_Ant Aux
DUT: 9560NGW; Type: Intel Wireless-AC 9560

Communication System: UID 0, Bluetooth (0); Frequency: 2402 MHz; Duty Cycle: 1:1
 Medium parameters used (interpolated): $f = 2402$ MHz; $\sigma = 1.956$ S/m; $\epsilon_r = 54.13$; $\rho = 1000$ kg/m³
 Phantom section: Flat Section
 Measurement Standard: DASYS (IEEE/IEC/ANSI C63.19-2007)
 DASYS.2 Configuration:

- Area Scan setting - Find Secondary Maximum Within: 2.0dB and with a peak SAR value greater than 0.5 W/Kg
- Probe: EX3DV4 - SN3977; ConvF(7.56, 7.56, 7.56); Calibrated: 2018/8/30
- Sensor-Surface: 1.4mm (Mechanical Surface Detection)
- Electronics: DAE4 Sn779; Calibrated: 2018/8/14
- Phantom: ELI V5.0 (20deg probe tilt); Type: QD OVA 002 AA; Serial: 1133
- Measurement SW: DASYS2, Version 52.10 (2); SEMCAD X Version 14.6.10 (7331)

Area Scan (101x81x1): Interpolated grid: dx=1.200 mm, dy=1.200 mm
 Maximum value of SAR (interpolated) = 0.157 W/kg

Zoom Scan (7x7x7)/Cube 0: Measurement grid: dx=5mm, dy=5mm, dz=5mm
 Reference Value = 9.614 V/m; Power Drift = -0.19 dB
 Peak SAR (extrapolated) = 0.213 W/kg

SAR(1 g) = 0.096 W/kg; SAR(10 g) = 0.044 W/kg
 Maximum value of SAR (measured) = 0.165 W/kg

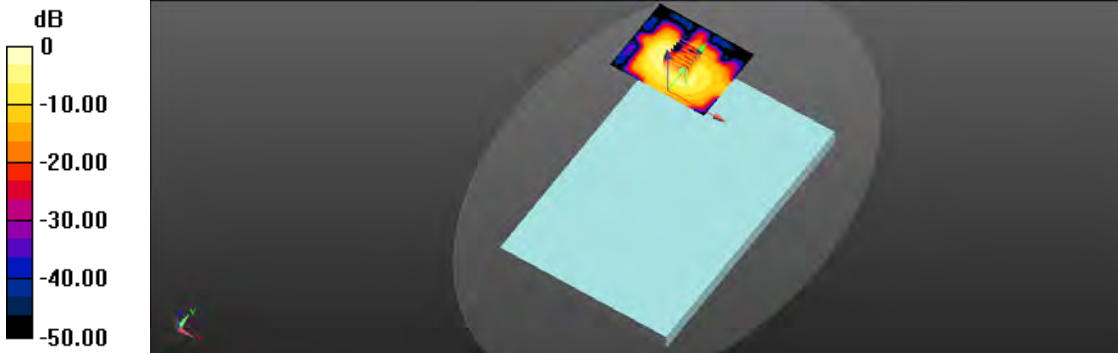

0 dB = 0.165 W/kg = -7.83 dBW/kg

Test Laboratory: A Test Lab Techno Corp.
 Date/Time: 2019/4/4 PM 05:38:23
 16_Bluetooth CH39_1M_Bottom of laptop_0mm_Ant Aux
DUT: 9560NGW; Type: Intel Wireless-AC 9560

Communication System: UID 0, Bluetooth (0); Frequency: 2441 MHz; Duty Cycle: 1:1
 Medium parameters used (interpolated): $f = 2441$ MHz; $\sigma = 2.004$ S/m; $\epsilon_r = 53.968$; $\rho = 1000$ kg/m³
 Phantom section: Flat Section
 Measurement Standard: DASYS (IEEE/IEC/ANSI C63.19-2007)
 DASYS.2 Configuration:

- Area Scan setting - Find Secondary Maximum Within: 2.0dB and with a peak SAR value greater than 0.5 W/Kg
- Probe: EX3DV4 - SN3977; ConvF(7.56, 7.56, 7.56); Calibrated: 2018/8/30
- Sensor-Surface: 1.4mm (Mechanical Surface Detection)
- Electronics: DAE4 Sn779; Calibrated: 2018/8/14
- Phantom: ELI V5.0 (20deg probe tilt); Type: QD OVA 002 AA; Serial: 1133
- Measurement SW: DASYS2, Version 52.10 (2); SEMCAD X Version 14.6.10 (7331)

Area Scan (101x81x1): Interpolated grid: dx=1.200 mm, dy=1.200 mm
 Maximum value of SAR (interpolated) = 0.160 W/kg

Zoom Scan (7x7x7)/Cube 0: Measurement grid: dx=5mm, dy=5mm, dz=5mm
 Reference Value = 11.02 V/m; Power Drift = -0.13 dB
 Peak SAR (extrapolated) = 0.217 W/kg
SAR(1 g) = 0.096 W/kg; SAR(10 g) = 0.044 W/kg
 Maximum value of SAR (measured) = 0.168 W/kg

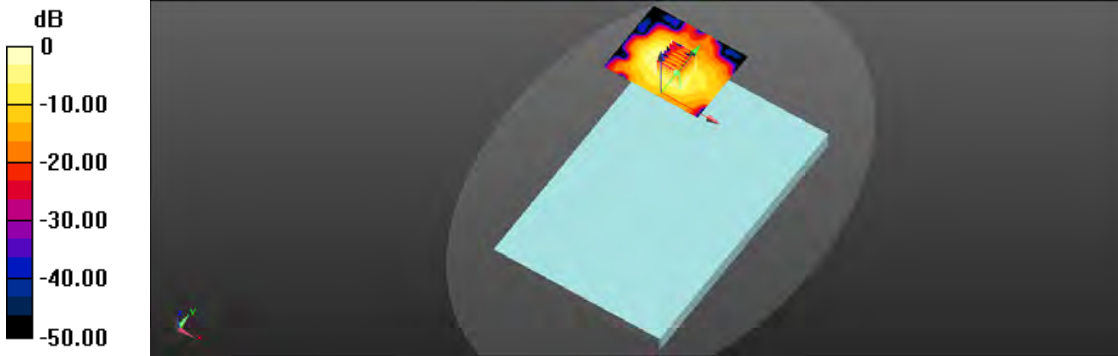

0 dB = 0.168 W/kg = -7.75 dBW/kg

Test Laboratory: A Test Lab Techno Corp.
 Date/Time: 2019/4/4 PM 05:58:27
 17_Bluetooth CH78_1M_Bottom of laptop_0mm_Ant Aux
DUT: 9560NGW; Type: Intel Wireless-AC 9560

Communication System: UID 0, Bluetooth (0); Frequency: 2480 MHz; Duty Cycle: 1:1
 Medium parameters used: $f = 2480 \text{ MHz}$; $\sigma = 2.053 \text{ S/m}$; $\epsilon_r = 53.843$; $\rho = 1000 \text{ kg/m}^3$
 Phantom section: Flat Section
 Measurement Standard: DASY5 (IEEE/IEC/ANSI C63.19-2007)
 DASY5.2 Configuration:

- Area Scan setting - Find Secondary Maximum Within: 2.0dB and with a peak SAR value greater than 0.5 W/Kg
- Probe: EX3DV4 - SN3977; ConvF(7.56, 7.56, 7.56); Calibrated: 2018/8/30
- Sensor-Surface: 1.4mm (Mechanical Surface Detection)
- Electronics: DAE4 Sn779; Calibrated: 2018/8/14
- Phantom: ELI V5.0 (20deg probe tilt); Type: QD OVA 002 AA; Serial: 1133
- Measurement SW: DASY52, Version 52.10 (2); SEMCAD X Version 14.6.10 (7331)

Area Scan (101x81x1): Interpolated grid: $dx=1.200 \text{ mm}$, $dy=1.200 \text{ mm}$
 Maximum value of SAR (interpolated) = 0.125 W/kg

Zoom Scan (7x7x7)/Cube 0: Measurement grid: $dx=5\text{mm}$, $dy=5\text{mm}$, $dz=5\text{mm}$
 Reference Value = 11.03 V/m; Power Drift = -0.18 dB
 Peak SAR (extrapolated) = 0.168 W/kg

SAR(1 g) = 0.075 W/kg; SAR(10 g) = 0.034 W/kg
 Maximum value of SAR (measured) = 0.130 W/kg

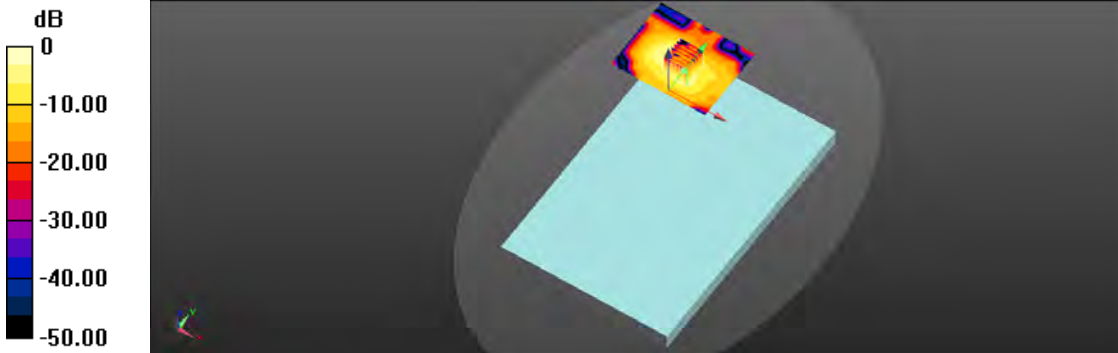

0 dB = 0.130 W/kg = -8.86 dBW/kg



Appendix C - Calibration

All of the instruments Calibration information are listed below.

- Dipole _ D2450V2 SN: 735
- Dipole _ D5GHzV2 SN: 1203
- Probe _ EX3DV4 SN: 3977
- DAE _ DAE4 SN: 779

**Calibration Laboratory of
Schmid & Partner
Engineering AG**
Zeughausstrasse 43, 8004 Zurich, Switzerland



S Schweizerischer Kalibrierdienst
C Service suisse d'étalonnage
S Servizio svizzero di taratura
S Swiss Calibration Service

Accredited by the Swiss Accreditation Service (SAS)
The Swiss Accreditation Service is one of the signatories to the EA
Multilateral Agreement for the recognition of calibration certificates

Accreditation No.: **SCS 0108**

Client **Auden**

Certificate No: **D2450V2-735_Dec18**

CALIBRATION CERTIFICATE

Object **D2450V2 - SN:735**

Calibration procedure(s) **QA CAL-05.v10
Calibration procedure for dipole validation kits above 700 MHz**

Calibration date: **December 11, 2018**

This calibration certificate documents the traceability to national standards, which realize the physical units of measurements (SI).
The measurements and the uncertainties with confidence probability are given on the following pages and are part of the certificate.

All calibrations have been conducted in the closed laboratory facility: environment temperature (22 ± 3)°C and humidity < 70%.

Calibration Equipment used (M&TE critical for calibration)

Primary Standards	ID #	Cal Date (Certificate No.)	Scheduled Calibration
Power meter NRP	SN: 104778	04-Apr-18 (No. 217-02672/02673)	Apr-19
Power sensor NRP-Z91	SN: 103244	04-Apr-18 (No. 217-02672)	Apr-19
Power sensor NRP-Z91	SN: 103245	04-Apr-18 (No. 217-02673)	Apr-19
Reference 20 dB Attenuator	SN: 5058 (20k)	04-Apr-18 (No. 217-02682)	Apr-19
Type-N mismatch combination	SN: 5047.2 / 06327	04-Apr-18 (No. 217-02683)	Apr-19
Reference Probe EX3DV4	SN: 7349	30-Dec-17 (No. EX3-7349_Dec17)	Dec-18
DAE4	SN: 601	04-Oct-18 (No. DAE4-601_Oct18)	Oct-19
Secondary Standards	ID #	Check Date (in house)	Scheduled Check
Power meter EPM-442A	SN: GB37480704	07-Oct-15 (in house check Oct-18)	In house check: Oct-20
Power sensor HP 8481A	SN: US37292783	07-Oct-15 (in house check Oct-18)	In house check: Oct-20
Power sensor HP 8481A	SN: MY41092317	07-Oct-15 (in house check Oct-18)	In house check: Oct-20
RF generator R&S SMT-06	SN: 100972	15-Jun-15 (in house check Oct-18)	In house check: Oct-20
Network Analyzer Agilent E8358A	SN: US41080477	31-Mar-14 (in house check Oct-18)	In house check: Oct-19

Calibrated by: **Name: Jeton Kastrati, Function: Laboratory Technician**

Approved by: **Name: Katja Pokovic, Function: Technical Manager**

Signature



Issued: December 13, 2018

This calibration certificate shall not be reproduced except in full without written approval of the laboratory.

Calibration Laboratory of
Schmid & Partner
Engineering AG
 Zeughausstrasse 43, 8004 Zurich, Switzerland



S Schweizerischer Kalibrierdienst
S Service suisse d'étalonnage
C Servizio svizzero di taratura
S Swiss Calibration Service

Accredited by the Swiss Accreditation Service (SAS)
 The Swiss Accreditation Service is one of the signatories to the EA
 Multilateral Agreement for the recognition of calibration certificates

Accreditation No.: **SCS 0108**

Glossary:

TSL tissue simulating liquid
 ConvF sensitivity in TSL / NORM x,y,z
 N/A not applicable or not measured

Calibration is Performed According to the Following Standards:

- a) IEEE Std 1528-2013, "IEEE Recommended Practice for Determining the Peak Spatial-Averaged Specific Absorption Rate (SAR) in the Human Head from Wireless Communications Devices: Measurement Techniques", June 2013
- b) IEC 62209-1, "Measurement procedure for the assessment of Specific Absorption Rate (SAR) from hand-held and body-mounted devices used next to the ear (frequency range of 300 MHz to 6 GHz)", July 2016
- c) IEC 62209-2, "Procedure to determine the Specific Absorption Rate (SAR) for wireless communication devices used in close proximity to the human body (frequency range of 30 MHz to 6 GHz)", March 2010
- d) KDB 865664, "SAR Measurement Requirements for 100 MHz to 6 GHz"

Additional Documentation:

- e) DASY4/5 System Handbook

Methods Applied and Interpretation of Parameters:

- *Measurement Conditions:* Further details are available from the Validation Report at the end of the certificate. All figures stated in the certificate are valid at the frequency indicated.
- *Antenna Parameters with TSL:* The dipole is mounted with the spacer to position its feed point exactly below the center marking of the flat phantom section, with the arms oriented parallel to the body axis.
- *Feed Point Impedance and Return Loss:* These parameters are measured with the dipole positioned under the liquid filled phantom. The impedance stated is transformed from the measurement at the SMA connector to the feed point. The Return Loss ensures low reflected power. No uncertainty required.
- *Electrical Delay:* One-way delay between the SMA connector and the antenna feed point. No uncertainty required.
- *SAR measured:* SAR measured at the stated antenna input power.
- *SAR normalized:* SAR as measured, normalized to an input power of 1 W at the antenna connector.
- *SAR for nominal TSL parameters:* The measured TSL parameters are used to calculate the nominal SAR result.

The reported uncertainty of measurement is stated as the standard uncertainty of measurement multiplied by the coverage factor $k=2$, which for a normal distribution corresponds to a coverage probability of approximately 95%.

Measurement Conditions

DASY system configuration, as far as not given on page 1.

DASY Version	DASY5	V52.10.2
Extrapolation	Advanced Extrapolation	
Phantom	Modular Flat Phantom	
Distance Dipole Center - TSL	10 mm	with Spacer
Zoom Scan Resolution	dx, dy, dz = 5 mm	
Frequency	2450 MHz \pm 1 MHz	

Head TSL parameters

The following parameters and calculations were applied.

	Temperature	Permittivity	Conductivity
Nominal Head TSL parameters	22.0 °C	39.2	1.80 mho/m
Measured Head TSL parameters	(22.0 \pm 0.2) °C	37.8 \pm 6 %	1.86 mho/m \pm 6 %
Head TSL temperature change during test	< 0.5 °C	----	----

SAR result with Head TSL

SAR averaged over 1 cm ³ (1 g) of Head TSL	Condition	
SAR measured	250 mW input power	13.4 W/kg
SAR for nominal Head TSL parameters	normalized to 1W	52.3 W/kg \pm 17.0 % (k=2)

SAR averaged over 10 cm ³ (10 g) of Head TSL	condition	
SAR measured	250 mW input power	6.19 W/kg
SAR for nominal Head TSL parameters	normalized to 1W	24.4 W/kg \pm 16.5 % (k=2)

Body TSL parameters

The following parameters and calculations were applied.

	Temperature	Permittivity	Conductivity
Nominal Body TSL parameters	22.0 °C	52.7	1.95 mho/m
Measured Body TSL parameters	(22.0 \pm 0.2) °C	51.0 \pm 6 %	2.03 mho/m \pm 6 %
Body TSL temperature change during test	< 0.5 °C	----	----

SAR result with Body TSL

SAR averaged over 1 cm ³ (1 g) of Body TSL	Condition	
SAR measured	250 mW input power	12.9 W/kg
SAR for nominal Body TSL parameters	normalized to 1W	50.2 W/kg \pm 17.0 % (k=2)

SAR averaged over 10 cm ³ (10 g) of Body TSL	condition	
SAR measured	250 mW input power	6.01 W/kg
SAR for nominal Body TSL parameters	normalized to 1W	23.7 W/kg \pm 16.5 % (k=2)



Appendix (Additional assessments outside the scope of SCS 0108)

Antenna Parameters with Head TSL

Impedance, transformed to feed point	$55.3 \Omega + 5.7 j\Omega$
Return Loss	- 22.6 dB

Antenna Parameters with Body TSL

Impedance, transformed to feed point	$50.5 \Omega + 6.5 j\Omega$
Return Loss	- 23.8 dB

General Antenna Parameters and Design

Electrical Delay (one direction)	1.154 ns
----------------------------------	----------

After long term use with 100W radiated power, only a slight warming of the dipole near the feedpoint can be measured.

The dipole is made of standard semirigid coaxial cable. The center conductor of the feeding line is directly connected to the second arm of the dipole. The antenna is therefore short-circuited for DC-signals. On some of the dipoles, small end caps are added to the dipole arms in order to improve matching when loaded according to the position as explained in the "Measurement Conditions" paragraph. The SAR data are not affected by this change. The overall dipole length is still according to the Standard.

No excessive force must be applied to the dipole arms, because they might bend or the soldered connections near the feedpoint may be damaged.

Additional EUT Data

Manufactured by	SPEAG
Manufactured on	May 07, 2003

DASY5 Validation Report for Head TSL

Date: 11.12.2018

Test Laboratory: SPEAG, Zurich, Switzerland

DUT: Dipole 2450 MHz; Type: D2450V2; Serial: D2450V2 - SN:735

Communication System: UID 0 - CW; Frequency: 2450 MHz

Medium parameters used: $f = 2450$ MHz; $\sigma = 1.86$ S/m; $\epsilon_r = 37.8$; $\rho = 1000$ kg/m³

Phantom section: Flat Section

Measurement Standard: DASY5 (IEEE/IEC/ANSI C63.19-2011)

DASY52 Configuration:

- Probe: EX3DV4 - SN7349; ConvF(7.88, 7.88, 7.88) @ 2450 MHz; Calibrated: 30.12.2017
- Sensor-Surface: 1.4mm (Mechanical Surface Detection)
- Electronics: DAE4 Sn601; Calibrated: 04.10.2018
- Phantom: Flat Phantom 5.0 (front); Type: QD 000 P50 AA; Serial: 1001
- DASY52 52.10.2(1495); SEMCAD X 14.6.12(7450)

Dipole Calibration for Head Tissue/Pin=250 mW, d=10mm/Zoom Scan (7x7x7)/Cube 0:

Measurement grid: dx=5mm, dy=5mm, dz=5mm

Reference Value = 117.4 V/m; Power Drift = -0.04 dB

Peak SAR (extrapolated) = 27.2 W/kg

SAR(1 g) = 13.4 W/kg; SAR(10 g) = 6.19 W/kg

Maximum value of SAR (measured) = 22.4 W/kg

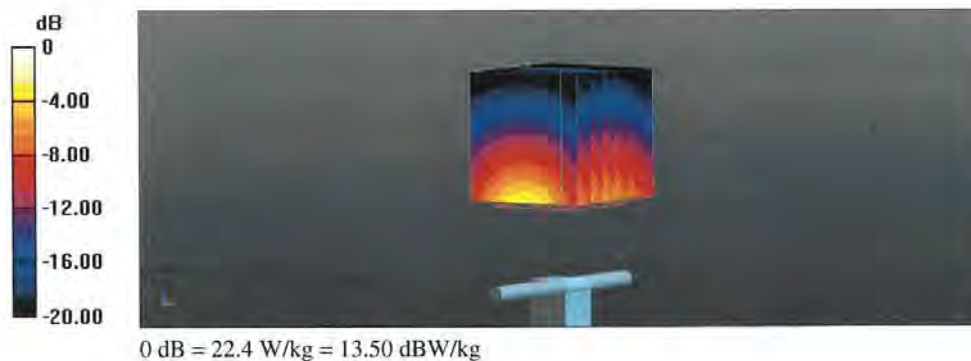



Impedance Measurement Plot for Head TSL

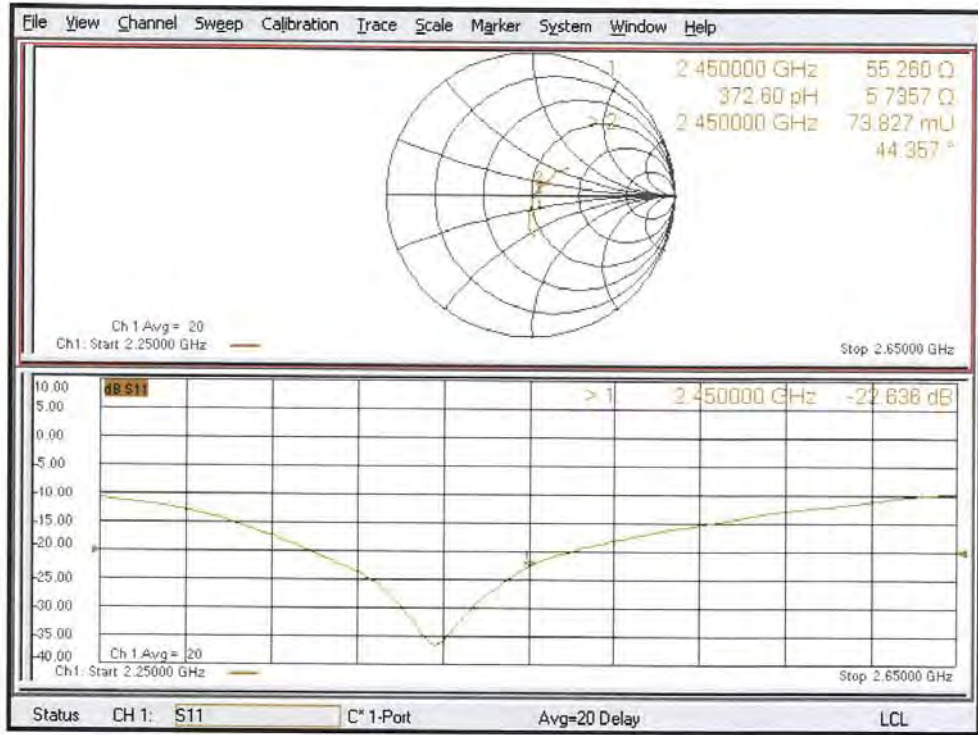

DASY5 Validation Report for Body TSL

Date: 11.12.2018

Test Laboratory: SPEAG, Zurich, Switzerland

DUT: Dipole 2450 MHz; Type: D2450V2; Serial: D2450V2 - SN:735

Communication System: UID 0 - CW; Frequency: 2450 MHz

Medium parameters used: $f = 2450$ MHz; $\sigma = 2.03$ S/m; $\epsilon_r = 51$; $\rho = 1000$ kg/m³

Phantom section: Flat Section

Measurement Standard: DASY5 (IEEE/IEC/ANSI C63.19-2011)

DASY52 Configuration:

- Probe: EX3DV4 - SN7349; ConvF(8.01, 8.01, 8.01) @ 2450 MHz; Calibrated: 30.12.2017
- Sensor-Surface: 1.4mm (Mechanical Surface Detection)
- Electronics: DAE4 Sn601; Calibrated: 04.10.2018
- Phantom: Flat Phantom 5.0 (back); Type: QD 000 P50 AA; Serial: 1002
- DASY52 52.10.2(1495); SEMCAD X 14.6.12(7450)

Dipole Calibration for Body Tissue/Pin=250 mW, d=10mm/Zoom Scan (7x7x7)/Cube 0:

Measurement grid: dx=5mm, dy=5mm, dz=5mm

Reference Value = 107.2 V/m; Power Drift = -0.03 dB

Peak SAR (extrapolated) = 25.8 W/kg

SAR(1 g) = 12.9 W/kg; SAR(10 g) = 6.01 W/kg

Maximum value of SAR (measured) = 21.0 W/kg





Impedance Measurement Plot for Body TSL

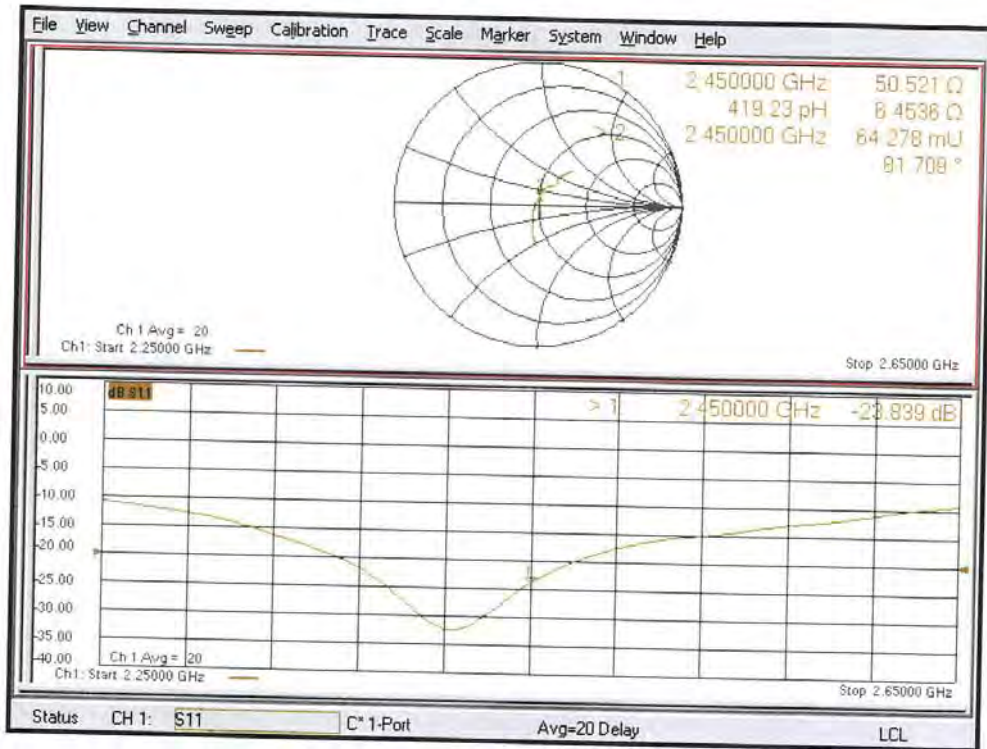

**Calibration Laboratory of
Schmid & Partner
Engineering AG**
Zeughausstrasse 43, 8004 Zurich, Switzerland



S Schweizerischer Kalibrierdienst
C Service suisse d'étalonnage
S Servizio svizzero di taratura
S Swiss Calibration Service

Accredited by the Swiss Accreditation Service (SAS)
The Swiss Accreditation Service is one of the signatories to the EA
Multilateral Agreement for the recognition of calibration certificates

Accreditation No.: **SCS 0108**

Client **Auden**

Certificate No: **D5GHzV2-1203_Dec18**

CALIBRATION CERTIFICATE

Object: **D5GHzV2 - SN:1203**

Calibration procedure(s): **QA CAL-22.v3
Calibration procedure for dipole validation kits between 3-6 GHz**

Calibration date: **December 13, 2018**

This calibration certificate documents the traceability to national standards, which realize the physical units of measurements (SI).
The measurements and the uncertainties with confidence probability are given on the following pages and are part of the certificate.

All calibrations have been conducted in the closed laboratory facility: environment temperature (22 ± 3)°C and humidity < 70%.

Calibration Equipment used (M&TE critical for calibration)

Primary Standards	ID #	Cal Date (Certificate No.)	Scheduled Calibration
Power meter NRP	SN: 104778	04-Apr-18 (No. 217-02672/02673)	Apr-19
Power sensor NRP-Z91	SN: 103244	04-Apr-18 (No. 217-02672)	Apr-19
Power sensor NRP-Z91	SN: 103245	04-Apr-18 (No. 217-02673)	Apr-19
Reference 20 dB Attenuator	SN: 5058 (20k)	04-Apr-18 (No. 217-02682)	Apr-19
Type-N mismatch combination	SN: 5047.2 / 06327	04-Apr-18 (No. 217-02683)	Apr-19
Reference Probe EX3DV4	SN: 3503	30-Dec-17 (No. EX3-3503_Dec17)	Dec-18
DAE4	SN: 601	04-Oct-18 (No. DAE4-601_Oct18)	Oct-19
Secondary Standards	ID #	Check Date (in house)	Scheduled Check
Power meter EPM-442A	SN: GB37480704	07-Oct-15 (in house check Oct-18)	In house check: Oct-20
Power sensor HP 8481A	SN: US37292783	07-Oct-15 (in house check Oct-18)	In house check: Oct-20
Power sensor HP 8481A	SN: MY41092317	07-Oct-15 (in house check Oct-18)	In house check: Oct-20
RF generator R&S SMT-06	SN: 100972	15-Jun-15 (in house check Oct-18)	In house check: Oct-20
Network Analyzer Agilent E8358A	SN: US41080477	31-Mar-14 (in house check Oct-18)	In house check: Oct-19

Calibrated by: **Jeton Kastrati** (Laboratory Technician) [Signature]

Approved by: **Katja Pokovic** (Technical Manager) [Signature]

Issued: December 14, 2018

This calibration certificate shall not be reproduced except in full without written approval of the laboratory.

Calibration Laboratory of
 Schmid & Partner
 Engineering AG
 Zeughausstrasse 43, 8004 Zurich, Switzerland



S Schweizerischer Kalibrierdienst
C Service suisse d'étalonnage
S Servizio svizzero di taratura
S Swiss Calibration Service

Accredited by the Swiss Accreditation Service (SAS)
 The Swiss Accreditation Service is one of the signatories to the EA
 Multilateral Agreement for the recognition of calibration certificates

Accreditation No.: **SCS 0108**

Glossary:

TSL tissue simulating liquid
 ConvF sensitivity in TSL / NORM x,y,z
 N/A not applicable or not measured

Calibration is Performed According to the Following Standards:

- a) IEEE Std 1528-2013, "IEEE Recommended Practice for Determining the Peak Spatial-Averaged Specific Absorption Rate (SAR) in the Human Head from Wireless Communications Devices: Measurement Techniques", June 2013
- b) IEC 62209-1, "Measurement procedure for the assessment of Specific Absorption Rate (SAR) from hand-held and body-mounted devices used next to the ear (frequency range of 300 MHz to 6 GHz)", July 2016
- c) IEC 62209-2, "Procedure to determine the Specific Absorption Rate (SAR) for wireless communication devices used in close proximity to the human body (frequency range of 30 MHz to 6 GHz)", March 2010
- d) KDB 865664, "SAR Measurement Requirements for 100 MHz to 6 GHz"

Additional Documentation:

- e) DASY4/5 System Handbook

Methods Applied and Interpretation of Parameters:

- *Measurement Conditions:* Further details are available from the Validation Report at the end of the certificate. All figures stated in the certificate are valid at the frequency indicated.
- *Antenna Parameters with TSL:* The dipole is mounted with the spacer to position its feed point exactly below the center marking of the flat phantom section, with the arms oriented parallel to the body axis.
- *Feed Point Impedance and Return Loss:* These parameters are measured with the dipole positioned under the liquid filled phantom. The impedance stated is transformed from the measurement at the SMA connector to the feed point. The Return Loss ensures low reflected power. No uncertainty required.
- *Electrical Delay:* One-way delay between the SMA connector and the antenna feed point. No uncertainty required.
- *SAR measured:* SAR measured at the stated antenna input power.
- *SAR normalized:* SAR as measured, normalized to an input power of 1 W at the antenna connector.
- *SAR for nominal TSL parameters:* The measured TSL parameters are used to calculate the nominal SAR result.

The reported uncertainty of measurement is stated as the standard uncertainty of measurement multiplied by the coverage factor $k=2$, which for a normal distribution corresponds to a coverage probability of approximately 95%.



Measurement Conditions

DASY system configuration, as far as not given on page 1.

DASY Version	DASY5	V52.10.2
Extrapolation	Advanced Extrapolation	
Phantom	Modular Flat Phantom V5.0	
Distance Dipole Center - TSL	10 mm	with Spacer
Zoom Scan Resolution	dx, dy = 4.0 mm, dz = 1.4 mm	Graded Ratio = 1.4 (Z direction)
Frequency	5250 MHz ± 1 MHz 5600 MHz ± 1 MHz 5750 MHz ± 1 MHz	

Head TSL parameters at 5250 MHz

The following parameters and calculations were applied.

	Temperature	Permittivity	Conductivity
Nominal Head TSL parameters	22.0 °C	35.9	4.71 mho/m
Measured Head TSL parameters	(22.0 ± 0.2) °C	36.3 ± 6 %	4.58 mho/m ± 6 %
Head TSL temperature change during test	< 0.5 °C	----	----

SAR result with Head TSL at 5250 MHz

SAR averaged over 1 cm ³ (1 g) of Head TSL	Condition	
SAR measured	100 mW input power	8.06 W/kg
SAR for nominal Head TSL parameters	normalized to 1W	80.7 W/kg ± 19.9 % (k=2)

SAR averaged over 10 cm ³ (10 g) of Head TSL	condition	
SAR measured	100 mW input power	2.33 W/kg
SAR for nominal Head TSL parameters	normalized to 1W	23.3 W/kg ± 19.5 % (k=2)



Head TSL parameters at 5600 MHz

The following parameters and calculations were applied.

	Temperature	Permittivity	Conductivity
Nominal Head TSL parameters	22.0 °C	35.5	5.07 mho/m
Measured Head TSL parameters	(22.0 ± 0.2) °C	35.8 ± 6 %	4.95 mho/m ± 6 %
Head TSL temperature change during test	< 0.5 °C	----	----

SAR result with Head TSL at 5600 MHz

SAR averaged over 1 cm ³ (1 g) of Head TSL	Condition	
SAR measured	100 mW input power	8.37 W/kg
SAR for nominal Head TSL parameters	normalized to 1W	83.7 W / kg ± 19.9 % (k=2)

SAR averaged over 10 cm ³ (10 g) of Head TSL	condition	
SAR measured	100 mW input power	2.40 W/kg
SAR for nominal Head TSL parameters	normalized to 1W	24.0 W/kg ± 19.5 % (k=2)

Head TSL parameters at 5750 MHz

The following parameters and calculations were applied.

	Temperature	Permittivity	Conductivity
Nominal Head TSL parameters	22.0 °C	35.4	5.22 mho/m
Measured Head TSL parameters	(22.0 ± 0.2) °C	35.6 ± 6 %	5.11 mho/m ± 6 %
Head TSL temperature change during test	< 0.5 °C	----	----

SAR result with Head TSL at 5750 MHz

SAR averaged over 1 cm ³ (1 g) of Head TSL	Condition	
SAR measured	100 mW input power	7.98 W/kg
SAR for nominal Head TSL parameters	normalized to 1W	79.8 W/kg ± 19.9 % (k=2)

SAR averaged over 10 cm ³ (10 g) of Head TSL	condition	
SAR measured	100 mW input power	2.28 W/kg
SAR for nominal Head TSL parameters	normalized to 1W	22.8 W/kg ± 19.5 % (k=2)



Body TSL parameters at 5250 MHz

The following parameters and calculations were applied.

	Temperature	Permittivity	Conductivity
Nominal Body TSL parameters	22.0 °C	48.9	5.36 mho/m
Measured Body TSL parameters	(22.0 ± 0.2) °C	47.4 ± 6 %	5.51 mho/m ± 6 %
Body TSL temperature change during test	< 0.5 °C	----	----

SAR result with Body TSL at 5250 MHz

SAR averaged over 1 cm ³ (1 g) of Body TSL	Condition	
SAR measured	100 mW input power	7.53 W/kg
SAR for nominal Body TSL parameters	normalized to 1W	74.9 W/kg ± 19.9 % (k=2)

SAR averaged over 10 cm ³ (10 g) of Body TSL	condition	
SAR measured	100 mW input power	2.10 W/kg
SAR for nominal Body TSL parameters	normalized to 1W	20.9 W/kg ± 19.5 % (k=2)

Body TSL parameters at 5600 MHz

The following parameters and calculations were applied.

	Temperature	Permittivity	Conductivity
Nominal Body TSL parameters	22.0 °C	48.5	5.77 mho/m
Measured Body TSL parameters	(22.0 ± 0.2) °C	46.8 ± 6 %	5.99 mho/m ± 6 %
Body TSL temperature change during test	< 0.5 °C	----	----

SAR result with Body TSL at 5600 MHz

SAR averaged over 1 cm ³ (1 g) of Body TSL	Condition	
SAR measured	100 mW input power	8.02 W/kg
SAR for nominal Body TSL parameters	normalized to 1W	79.7 W/kg ± 19.9 % (k=2)

SAR averaged over 10 cm ³ (10 g) of Body TSL	condition	
SAR measured	100 mW input power	2.25 W/kg
SAR for nominal Body TSL parameters	normalized to 1W	22.3 W/kg ± 19.5 % (k=2)



Body TSL parameters at 5750 MHz

The following parameters and calculations were applied.

	Temperature	Permittivity	Conductivity
Nominal Body TSL parameters	22.0 °C	48.3	5.94 mho/m
Measured Body TSL parameters	(22.0 ± 0.2) °C	46.5 ± 6 %	6.20 mho/m ± 6 %
Body TSL temperature change during test	< 0.5 °C	----	----

SAR result with Body TSL at 5750 MHz

SAR averaged over 1 cm ³ (1 g) of Body TSL	Condition	
SAR measured	100 mW input power	7.72 W/kg
SAR for nominal Body TSL parameters	normalized to 1W	76.8 W/kg ± 19.9 % (k=2)

SAR averaged over 10 cm ³ (10 g) of Body TSL	condition	
SAR measured	100 mW input power	2.15 W/kg
SAR for nominal Body TSL parameters	normalized to 1W	21.3 W/kg ± 19.5 % (k=2)

Appendix (Additional assessments outside the scope of SCS 0108)

Antenna Parameters with Head TSL at 5250 MHz

Impedance, transformed to feed point	48.4 Ω - 3.0 j Ω
Return Loss	- 29,2 dB

Antenna Parameters with Head TSL at 5600 MHz

Impedance, transformed to feed point	52.8 Ω + 1.4 j Ω
Return Loss	- 30,4 dB

Antenna Parameters with Head TSL at 5750 MHz

Impedance, transformed to feed point	53.4 Ω + 6.7 j Ω
Return Loss	- 22,7 dB

Antenna Parameters with Body TSL at 5250 MHz

Impedance, transformed to feed point	48.9 Ω - 2.2 j Ω
Return Loss	- 32,1 dB

Antenna Parameters with Body TSL at 5600 MHz

Impedance, transformed to feed point	53.8 Ω + 2.5 j Ω
Return Loss	- 27,2 dB

Antenna Parameters with Body TSL at 5750 MHz

Impedance, transformed to feed point	54.0 Ω + 6.7 j Ω
Return Loss	- 22,5 dB

General Antenna Parameters and Design

Electrical Delay (one direction)	1.190 ns
----------------------------------	----------

After long term use with 100W radiated power, only a slight warming of the dipole near the feedpoint can be measured.

The dipole is made of standard semirigid coaxial cable. The center conductor of the feeding line is directly connected to the second arm of the dipole. The antenna is therefore short-circuited for DC-signals. On some of the dipoles, small end caps are added to the dipole arms in order to improve matching when loaded according to the position as explained in the "Measurement Conditions" paragraph. The SAR data are not affected by this change. The overall dipole length is still according to the Standard.

No excessive force must be applied to the dipole arms, because they might bend or the soldered connections near the feedpoint may be damaged.

Additional EUT Data

Manufactured by	SPEAG
Manufactured on	September 11, 2014

DASY5 Validation Report for Head TSL

Date: 13.12.2018

Test Laboratory: SPEAG, Zurich, Switzerland

DUT: Dipole D5GHzV2; Type: D5GHzV2; Serial: D5GHzV2 - SN:1203

Communication System: UID 0 - CW; Frequency: 5250 MHz, Frequency: 5600 MHz, Frequency: 5750 MHz

Medium parameters used: $f = 5250$ MHz; $\sigma = 4.58$ S/m; $\epsilon_r = 36.3$; $\rho = 1000$ kg/m³,

Medium parameters used: $f = 5600$ MHz; $\sigma = 4.95$ S/m; $\epsilon_r = 35.8$; $\rho = 1000$ kg/m³,

Medium parameters used: $f = 5750$ MHz; $\sigma = 5.11$ S/m; $\epsilon_r = 35.6$; $\rho = 1000$ kg/m³

Phantom section: Flat Section

Measurement Standard: DASY5 (IEEE/IEC/ANSI C63.19-2011)

DASY52 Configuration:

- Probe: EX3DV4 - SN3503; ConvF(5.51, 5.51, 5.51) @ 5250 MHz, ConvF(5.05, 5.05, 5.05) @ 5600 MHz, ConvF(4.98, 4.98, 4.98) @ 5750 MHz; Calibrated: 30.12.2017
- Sensor-Surface: 1.4mm (Mechanical Surface Detection)
- Electronics: DAE4 Sn601 (5G); Calibrated: 04.10.2018
- Phantom: Flat Phantom 5.0 (front); Type: QD 000 P50 AA; Serial: 1001
- DASY52 52.10.2(1495); SEMCAD X 14.6.12(7450)

Dipole Calibration for Head Tissue/Pin=100mW, dist=10mm, f=5250 MHz/Zoom Scan,

dist=1.4mm (8x8x7)/Cube 0: Measurement grid: dx=4mm, dy=4mm, dz=1.4mm

Reference Value = 76.62 V/m; Power Drift = 0.06 dB

Peak SAR (extrapolated) = 27.1 W/kg

SAR(1 g) = 8.06 W/kg; SAR(10 g) = 2.33 W/kg

Maximum value of SAR (measured) = 18.8 W/kg

Dipole Calibration for Head Tissue/Pin=100mW, dist=10mm, f=5600 MHz/Zoom Scan,

dist=1.4mm (8x8x7)/Cube 0: Measurement grid: dx=4mm, dy=4mm, dz=1.4mm

Reference Value = 76.75 V/m; Power Drift = -0.09 dB

Peak SAR (extrapolated) = 30.8 W/kg

SAR(1 g) = 8.37 W/kg; SAR(10 g) = 2.4 W/kg

Maximum value of SAR (measured) = 20.0 W/kg

Dipole Calibration for Head Tissue/Pin=100mW, dist=10mm, f=5750 MHz/Zoom Scan,

dist=1.4mm (8x8x7)/Cube 0: Measurement grid: dx=4mm, dy=4mm, dz=1.4mm

Reference Value = 75.01 V/m; Power Drift = -0.08 dB

Peak SAR (extrapolated) = 30.0 W/kg

SAR(1 g) = 7.98 W/kg; SAR(10 g) = 2.28 W/kg

Maximum value of SAR (measured) = 19.3 W/kg

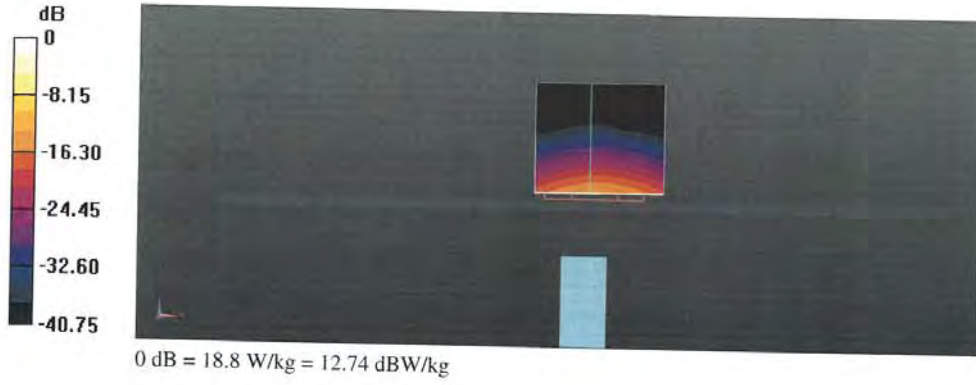

Impedance Measurement Plot for Head TSL

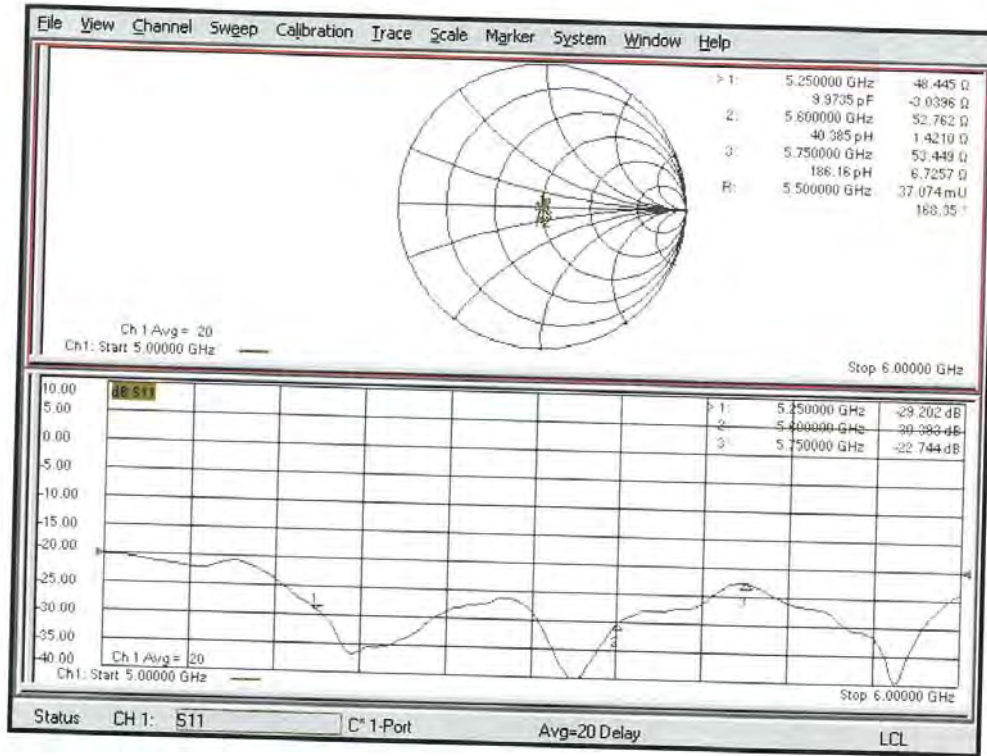

DASY5 Validation Report for Body TSL

Date: 13.12.2018

Test Laboratory: SPEAG, Zurich, Switzerland

DUT: Dipole D5GHzV2; Type: D5GHzV2; Serial: D5GHzV2 - SN:1203

Communication System: UID 0 - CW; Frequency: 5250 MHz, Frequency: 5600 MHz, Frequency: 5750 MHz
 Medium parameters used: $f = 5250$ MHz; $\sigma = 5.51$ S/m; $\epsilon_r = 47.4$; $\rho = 1000$ kg/m³,
 Medium parameters used: $f = 5600$ MHz; $\sigma = 5.99$ S/m; $\epsilon_r = 46.8$; $\rho = 1000$ kg/m³,
 Medium parameters used: $f = 5750$ MHz; $\sigma = 6.2$ S/m; $\epsilon_r = 46.5$; $\rho = 1000$ kg/m³,
 Phantom section: Flat Section
 Measurement Standard: DASY5 (IEEE/IEC/ANSI C63.19-2011)

DASY52 Configuration:

- Probe: EX3DV4 - SN3503; ConvF(5.26, 5.26, 5.26) @ 5250 MHz, ConvF(4.65, 4.65, 4.65) @ 5600 MHz, ConvF(4.57, 4.57, 4.57) @ 5750 MHz; Calibrated: 30.12.2017
- Sensor-Surface: 1.4mm (Mechanical Surface Detection)
- Electronics: DAE4 Sn601 (5G); Calibrated: 04.10.2018
- Phantom: Flat Phantom 5.0 (back); Type: QD 000 P50 AA; Serial: 1002
- DASY52 52.10.2(1495); SEMCAD X 14.6.12(7450)

Dipole Calibration for Body Tissue/Pin=100mW, dist=10mm, f=5250 MHz/Zoom Scan, dist=1.4mm (8x8x7)/Cube 0:

Measurement grid: dx=4mm, dy=4mm, dz=1.4mm
 Reference Value = 66.92 V/m; Power Drift = -0.08 dB

Peak SAR (extrapolated) = 29.3 W/kg

SAR(1 g) = 7.53 W/kg; SAR(10 g) = 2.1 W/kg

Maximum value of SAR (measured) = 17.5 W/kg

Dipole Calibration for Body Tissue/Pin=100mW, dist=10mm, f=5600 MHz/Zoom Scan, dist=1.4mm (8x8x7)/Cube 0:

Measurement grid: dx=4mm, dy=4mm, dz=1.4mm

Reference Value = 67.14 V/m; Power Drift = -0.06 dB

Peak SAR (extrapolated) = 34.0 W/kg

SAR(1 g) = 8.02 W/kg; SAR(10 g) = 2.25 W/kg

Maximum value of SAR (measured) = 19.2 W/kg

Dipole Calibration for Body Tissue/Pin=100mW, dist=10mm, f=5750 MHz/Zoom Scan, dist=1.4mm (8x8x7)/Cube 0:

Measurement grid: dx=4mm, dy=4mm, dz=1.4mm

Reference Value = 65.92 V/m; Power Drift = -0.07 dB

Peak SAR (extrapolated) = 33.3 W/kg

SAR(1 g) = 7.72 W/kg; SAR(10 g) = 2.15 W/kg

Maximum value of SAR (measured) = 18.8 W/kg

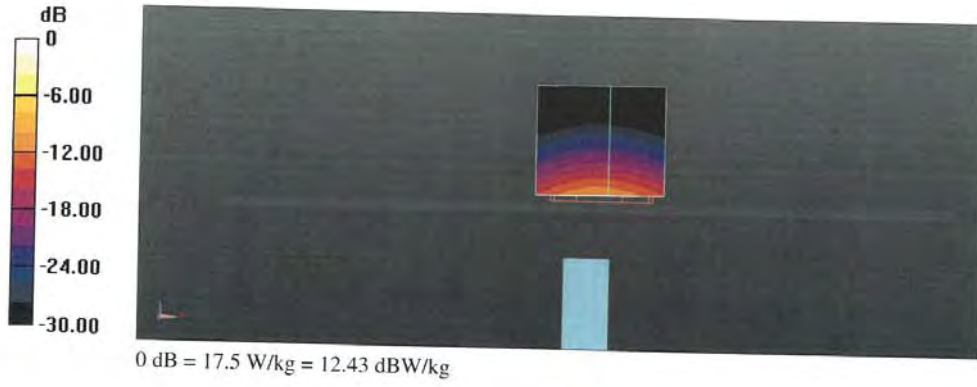



Impedance Measurement Plot for Body TSL

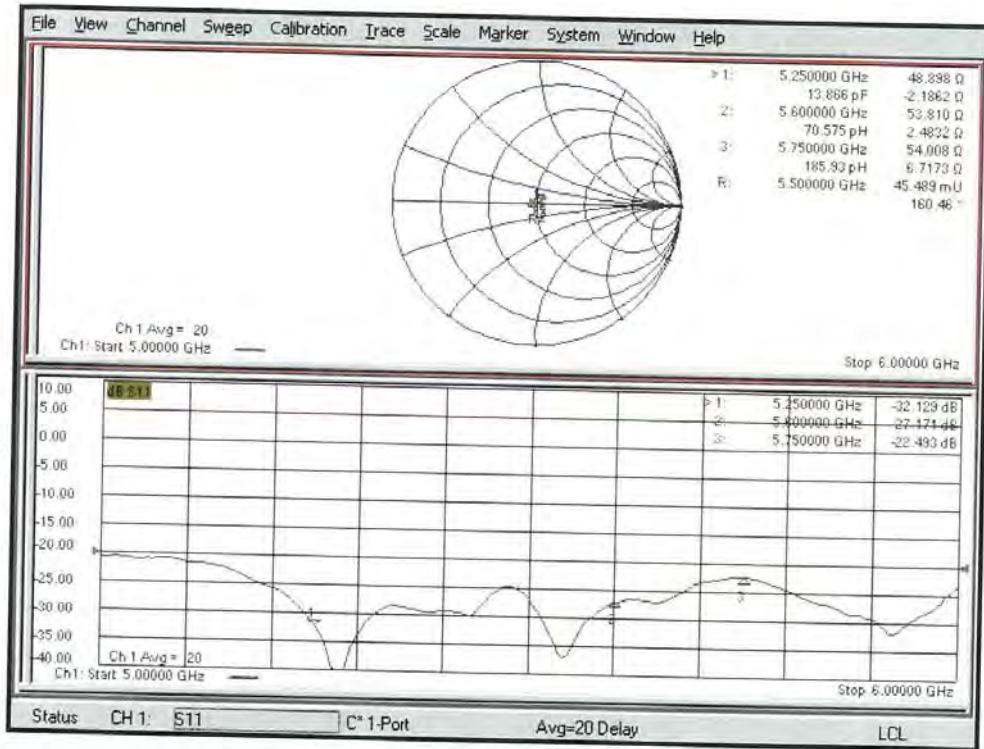



In Collaboration with
s p e a g
CALIBRATION LABORATORY



中国认可
国际互认
校准
CALIBRATION
CNAS L0570

Add: No.51 Xueyuan Road, Haidian District, Beijing, 100191, China
Tel: +86-10-62304633-2512 Fax: +86-10-62304633-2504
E-mail: cttl@chinattl.com [Http://www.chinattl.cn](http://www.chinattl.cn)

EX3DV4-SN-3977

Client **ATL**

Certificate No: **Z18-60288**

CALIBRATION CERTIFICATE

Object **EX3DV4 - SN:3977**

Calibration Procedure(s) **FF-Z11-004-01**
Calibration Procedures for Dosimetric E-field Probes

Calibration date: **August 30, 2018**

This calibration Certificate documents the traceability to national standards, which realize the physical units of measurements(SI). The measurements and the uncertainties with confidence probability are given on the following pages and are part of the certificate.

All calibrations have been conducted in the closed laboratory facility: environment temperature(22±3)°C and humidity<70%.

Calibration Equipment used (M&TE critical for calibration)

Primary Standards	ID #	Cal Date(Calibrated by, Certificate No.)	Scheduled Calibration
Power Meter NRP2	101919	20-Jun-18 (CTTL, No.J18X05032)	Jun-19
Power sensor NRP-Z91	101547	20-Jun-18 (CTTL, No.J18X05032)	Jun-19
Power sensor NRP-Z91	101548	20-Jun-18 (CTTL, No.J18X05032)	Jun-19
Reference10dBAttenuator	18N50W-10dB	09-Feb-18(CTTL, No.J18X01133)	Feb-20
Reference20dBAttenuator	18N50W-20dB	09-Feb-18(CTTL, No.J18X01132)	Feb-20
Reference Probe EX3DV4	SN 3846	25-Jan-18(SPEAG,No.EX3-3846_Jan18)	Jan-19
DAE4	SN 777	15-Dec-17(SPEAG, No.DAE4-777_Dec17)	Dec -18
Secondary Standards	ID #	Cal Date(Calibrated by, Certificate No.)	Scheduled Calibration
SignalGeneratorMG3700A	6201052605	21-Jun-18 (CTTL, No.J18X05033)	Jun-19
Network Analyzer E5071C	MY46110673	14-Jan-18 (CTTL, No.J18X00561)	Jan -19

	Name	Function	Signature
Calibrated by:	Yu Zongying	SAR Test Engineer	
Reviewed by:	Lin Hao	SAR Test Engineer	
Approved by:	Qi Dianyuan	SAR Project Leader	

Issued: August 31, 2018

This calibration certificate shall not be reproduced except in full without written approval of the laboratory.

Glossary:

TSL	tissue simulating liquid
NORM _{x,y,z}	sensitivity in free space
ConvF	sensitivity in TSL / NORM _{x,y,z}
DCP	diode compression point
CF	crest factor (1/duty_cycle) of the RF signal
A,B,C,D	modulation dependent linearization parameters
Polarization Φ	Φ rotation around probe axis
Polarization θ	θ rotation around an axis that is in the plane normal to probe axis (at measurement center), $\theta=0$ is normal to probe axis

Connector Angle information used in DASY system to align probe sensor X to the robot coordinate system

Calibration is Performed According to the Following Standards:

- IEEE Std 1528-2013, "IEEE Recommended Practice for Determining the Peak Spatial-Averaged Specific Absorption Rate (SAR) in the Human Head from Wireless Communications Devices: Measurement Techniques", June 2013
- IEC 62209-1, "Measurement procedure for the assessment of Specific Absorption Rate (SAR) from hand-held and body-mounted devices used next to the ear (frequency range of 300 MHz to 6 GHz)", July 2016
- IEC 62209-2, "Procedure to determine the Specific Absorption Rate (SAR) for wireless communication devices used in close proximity to the human body (frequency range of 30 MHz to 6 GHz)", March 2010
- KDB 865664, "SAR Measurement Requirements for 100 MHz to 6 GHz"

Methods Applied and Interpretation of Parameters:

- NORM_{x,y,z}**: Assessed for E-field polarization $\theta=0$ ($f \leq 900\text{MHz}$ in TEM-cell; $f > 1800\text{MHz}$: waveguide). NORM_{x,y,z} are only intermediate values, i.e., the uncertainties of NORM_{x,y,z} does not effect the E^2 -field uncertainty inside TSL (see below ConvF).
- NORM(f)_{x,y,z}** = NORM_{x,y,z} * frequency_response (see Frequency Response Chart). This linearization is implemented in DASY4 software versions later than 4.2. The uncertainty of the frequency response is included in the stated uncertainty of ConvF.
- DCP_{x,y,z}**: DCP are numerical linearization parameters assessed based on the data of power sweep (no uncertainty required). DCP does not depend on frequency nor media.
- PAR**: PAR is the Peak to Average Ratio that is not calibrated but determined based on the signal characteristics.
- A_{x,y,z}; B_{x,y,z}; C_{x,y,z}; VR_{x,y,z}; A,B,C** are numerical linearization parameters assessed based on the data of power sweep for specific modulation signal. The parameters do not depend on frequency nor media. VR is the maximum calibration range expressed in RMS voltage across the diode.
- ConvF and Boundary Effect Parameters**: Assessed in flat phantom using E-field (or Temperature Transfer Standard for $f \leq 800\text{MHz}$) and inside waveguide using analytical field distributions based on power measurements for $f > 800\text{MHz}$. The same setups are used for assessment of the parameters applied for boundary compensation (alpha, depth) of which typical uncertainty valued are given. These parameters are used in DASY4 software to improve probe accuracy close to the boundary. The sensitivity in TSL corresponds to NORM_{x,y,z} ConvF whereby the uncertainty corresponds to that given for ConvF. A frequency dependent ConvF is used in DASY version 4.4 and higher which allows extending the validity from $\pm 50\text{MHz}$ to $\pm 100\text{MHz}$.
- Spherical isotropy (3D deviation from isotropy)**: in a field of low gradients realized using a flat phantom exposed by a patch antenna.
- Sensor Offset**: The sensor offset corresponds to the offset of virtual measurement center from the probe tip (on probe axis). No tolerance required.
- Connector Angle**: The angle is assessed using the information gained by determining the NORM_x (no uncertainty required).



Add: No.51 Xueyuan Road, Haidian District, Beijing, 100191, China
Tel: +86-10-62304633-2512 Fax: +86-10-62304633-2504
E-mail: cttl@chinattl.com [Http://www.chinattl.cn](http://www.chinattl.cn)

Probe EX3DV4

SN: 3977

Calibrated: August 30, 2018

Calibrated for DASY/EASY Systems

(Note: non-compatible with DASY2 system!)

DASY/EASY – Parameters of Probe: EX3DV4 – SN: 3977

Basic Calibration Parameters

	Sensor X	Sensor Y	Sensor Z	Unc (k=2)
Norm($\mu\text{V}/(\text{V}/\text{m})^2$) ^A	0.53	0.58	0.52	$\pm 10.0\%$
DCP(mV) ^B	102.4	101.8	101.8	

Modulation Calibration Parameters

UID	Communication System Name		A dB	B dB μV	C	D dB	VR mV	Unc ^E (k=2)
0	CW	X	0.0	0.0	1.0	0.00	180.7	$\pm 2.0\%$
		Y	0.0	0.0	1.0		188.7	
		Z	0.0	0.0	1.0		176.8	

The reported uncertainty of measurement is stated as the standard uncertainty of Measurement multiplied by the coverage factor k=2, which for a normal distribution Corresponds to a coverage probability of approximately 95%.

^A The uncertainties of Norm X, Y, Z do not affect the E²-field uncertainty inside TSL (see Page 5 and Page 6).

^B Numerical linearization parameter: uncertainty not required.

^E Uncertainty is determined using the max. deviation from linear response applying rectangular distribution and is expressed for the square of the field value.

DASY/EASY – Parameters of Probe: EX3DV4 – SN: 3977

Calibration Parameter Determined in Head Tissue Simulating Media

f [MHz] ^C	Relative Permittivity ^F	Conductivity (S/m) ^F	ConvF X	ConvF Y	ConvF Z	Alpha ^G	Depth ^G (mm)	Unct. (k=2)
750	41.9	0.89	10.18	10.18	10.18	0.40	0.80	± 12.1%
835	41.5	0.90	9.70	9.70	9.70	0.17	1.37	± 12.1%
1750	40.1	1.37	8.38	8.38	8.38	0.28	0.94	± 12.1%
1900	40.0	1.40	8.14	8.14	8.14	0.27	0.98	± 12.1%
2450	39.2	1.80	7.63	7.63	7.63	0.41	0.96	± 12.1%
2600	39.0	1.96	7.32	7.32	7.32	0.44	0.93	± 12.1%
5250	35.9	4.71	5.52	5.52	5.52	0.50	1.15	± 13.3%
5600	35.5	5.07	4.75	4.75	4.75	0.50	1.30	± 13.3%
5750	35.4	5.22	5.02	5.02	5.02	0.50	1.40	± 13.3%

^C Frequency validity above 300 MHz of ±100MHz only applies for DASY v4.4 and higher (Page 2), else it is restricted to ±50MHz. The uncertainty is the RSS of ConvF uncertainty at calibration frequency and the uncertainty for the indicated frequency band. Frequency validity below 300 MHz is ± 10, 25, 40, 50 and 70 MHz for ConvF assessments at 30, 64, 128, 150 and 220 MHz respectively. Above 5 GHz frequency validity can be extended to ± 110 MHz.

^F At frequency below 3 GHz, the validity of tissue parameters (ϵ and σ) can be relaxed to ±10% if liquid compensation formula is applied to measured SAR values. At frequencies above 3 GHz, the validity of tissue parameters (ϵ and σ) is restricted to ±5%. The uncertainty is the RSS of the ConvF uncertainty for indicated target tissue parameters.

^G Alpha/Depth are determined during calibration. SPEAG warrants that the remaining deviation due to the boundary effect after compensation is always less than ± 1% for frequencies below 3 GHz and below ± 2% for the frequencies between 3-6 GHz at any distance larger than half the probe tip diameter from the boundary.

DASY/EASY – Parameters of Probe: EX3DV4 – SN: 3977

Calibration Parameter Determined in Body Tissue Simulating Media

f [MHz] ^C	Relative Permittivity ^F	Conductivity (S/m) ^F	ConvF X	ConvF Y	ConvF Z	Alpha ^G	Depth ^G (mm)	Unct. (k=2)
750	55.5	0.96	10.27	10.27	10.27	0.40	0.80	± 12.1%
835	55.2	0.97	9.79	9.79	9.79	0.18	1.41	± 12.1%
1750	53.4	1.49	8.10	8.10	8.10	0.23	1.10	± 12.1%
1900	53.3	1.52	7.75	7.75	7.75	0.22	1.14	± 12.1%
2450	52.7	1.95	7.56	7.56	7.56	0.65	0.75	± 12.1%
2600	52.5	2.16	7.20	7.20	7.20	0.65	0.72	± 12.1%
5250	48.9	5.36	5.08	5.08	5.08	0.50	1.25	± 13.3%
5600	48.5	5.77	4.41	4.41	4.41	0.50	1.45	± 13.3%
5750	48.3	5.94	4.49	4.49	4.49	0.50	1.50	± 13.3%

^C Frequency validity above 300 MHz of ±100MHz only applies for DASY v4.4 and higher (Page 2), else it is restricted to ±50MHz. The uncertainty is the RSS of ConvF uncertainty at calibration frequency and the uncertainty for the indicated frequency band. Frequency validity below 300 MHz is ± 10, 25, 40, 50 and 70 MHz for ConvF assessments at 30, 64, 128, 150 and 220 MHz respectively. Above 5 GHz frequency validity can be extended to ± 110 MHz.

^F At frequency below 3 GHz, the validity of tissue parameters (ϵ and σ) can be relaxed to ±10% if liquid compensation formula is applied to measured SAR values. At frequencies above 3 GHz, the validity of tissue parameters (ϵ and σ) is restricted to ±5%. The uncertainty is the RSS of the ConvF uncertainty for indicated target tissue parameters.

^G Alpha/Depth are determined during calibration. SPEAG warrants that the remaining deviation due to the boundary effect after compensation is always less than ± 1% for frequencies below 3 GHz and below ± 2% for the frequencies between 3-6 GHz at any distance larger than half the probe tip diameter from the boundary.

Frequency Response of E-Field (TEM-Cell: ifi110 EXX, Waveguide: R22)

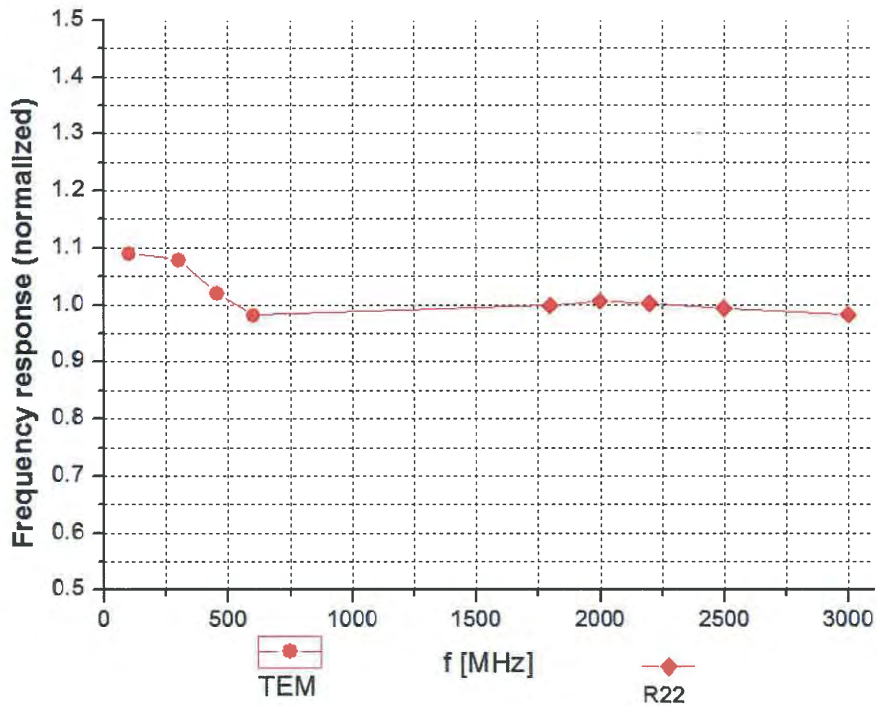

Uncertainty of Frequency Response of E-field: $\pm 7.4\%$ (k=2)

Receiving Pattern (Φ), $\theta=0^\circ$

f=600 MHz, TEM

f=1800 MHz, R22

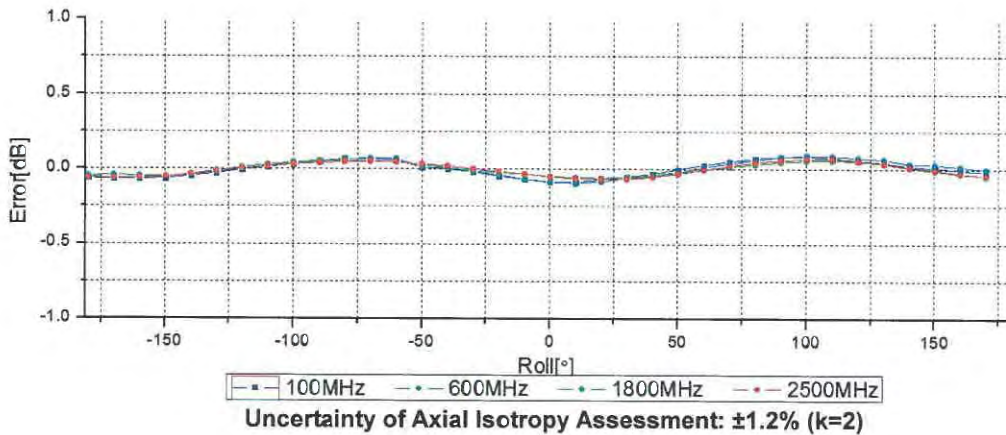
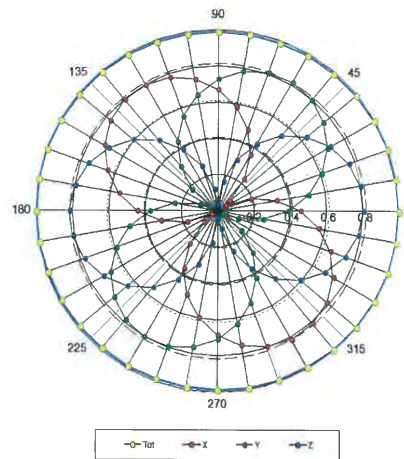
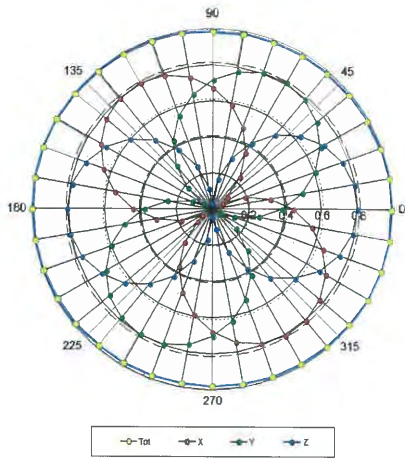

Dynamic Range $f(\text{SAR}_{\text{head}})$ (TEM cell, $f = 900 \text{ MHz}$)

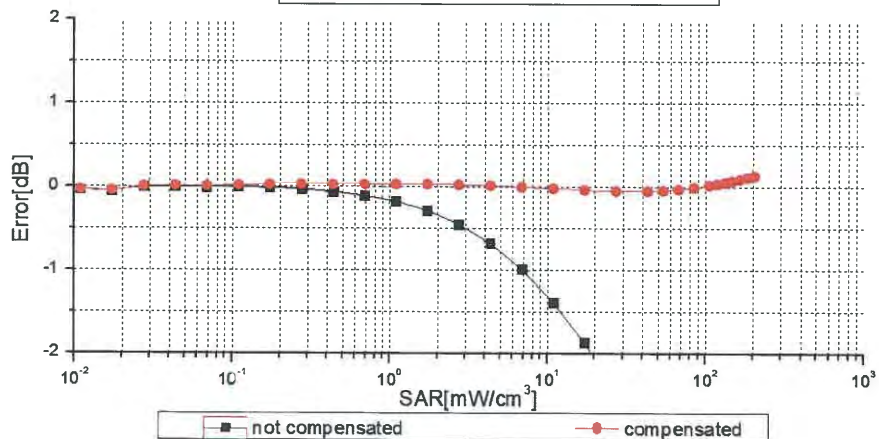
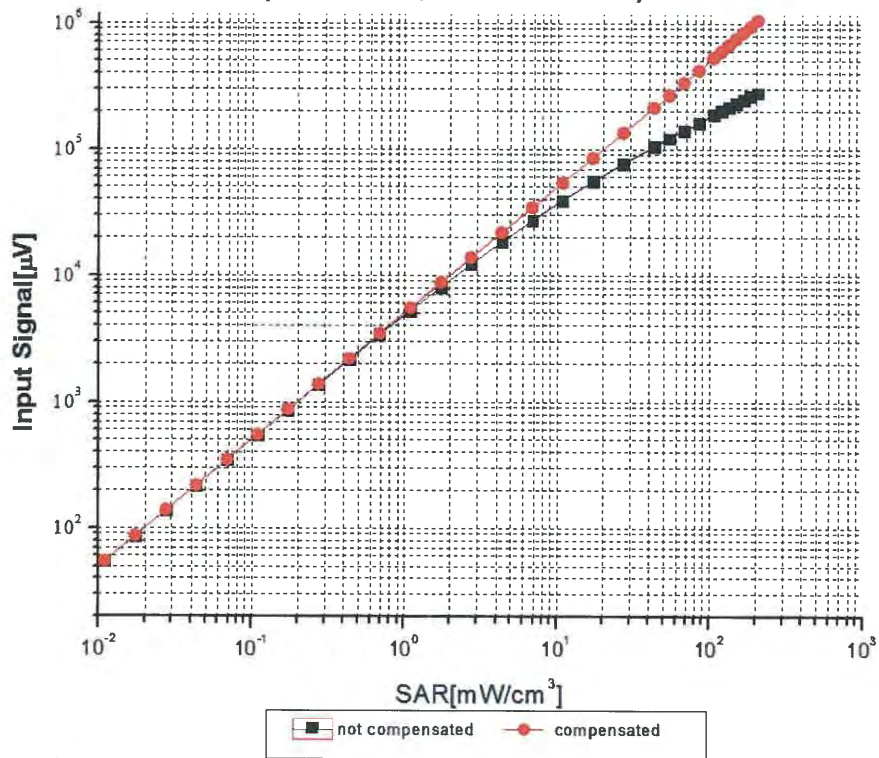

Uncertainty of Linearity Assessment: $\pm 0.9\%$ ($k=2$)

Conversion Factor Assessment

f=750 MHz, WGLS R9(H_convF)

f=1750 MHz, WGLS R22(H_convF)

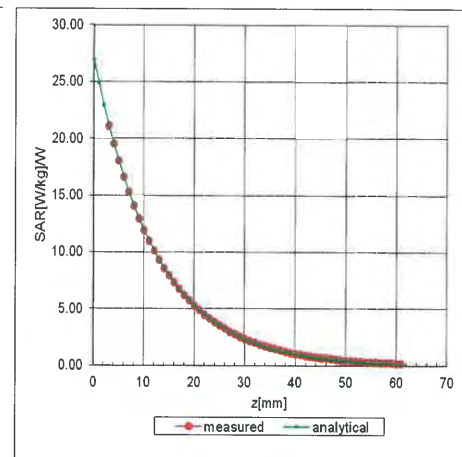
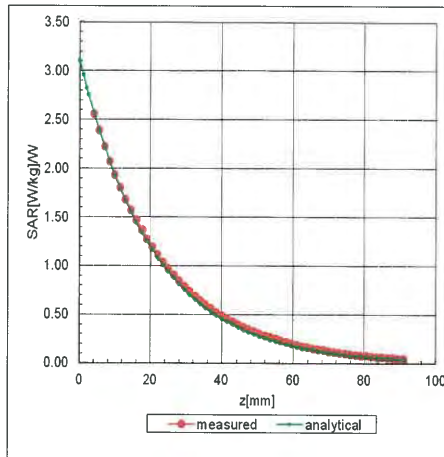

Deviation from Isotropy in Liquid

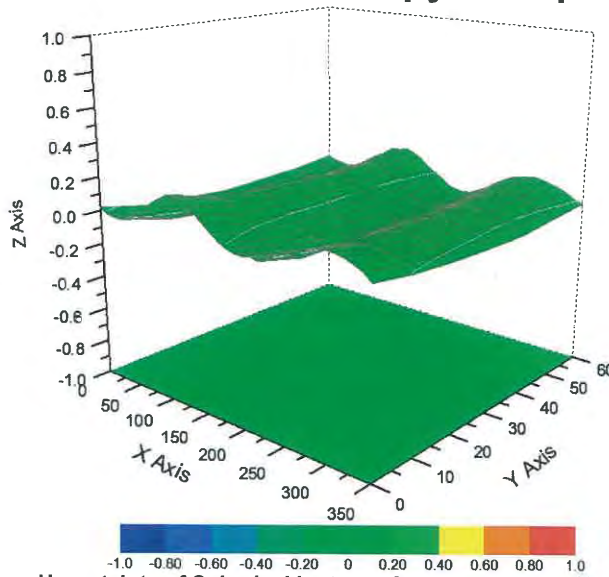

Uncertainty of Spherical Isotropy Assessment: $\pm 3.2\%$ (K=2)

DASY/EASY – Parameters of Probe: EX3DV4 – SN: 3977

Other Probe Parameters

Sensor Arrangement	Triangular
Connector Angle (°)	24.7
Mechanical Surface Detection Mode	enabled
Optical Surface Detection Mode	disable
Probe Overall Length	337mm
Probe Body Diameter	10mm
Tip Length	9mm
Tip Diameter	2.5mm
Probe Tip to Sensor X Calibration Point	1mm
Probe Tip to Sensor Y Calibration Point	1mm
Probe Tip to Sensor Z Calibration Point	1mm
Recommended Measurement Distance from Surface	1.4mm



In Collaboration with
s p e a g
CALIBRATION LABORATORY



中国认可
国际互认
校准
CALIBRATION
CNAS L0570

Add: No.51 Xueyuan Road, Haidian District, Beijing, 100191, China
Tel: +86-10-62304633-2512 Fax: +86-10-62304633-2504
E-mail: cttl@chinattl.com [Http://www.chinattl.cn](http://www.chinattl.cn)

Client : **ATL**

Certificate No: **Z18-60289**

CALIBRATION CERTIFICATE

Object: **DAE4 - SN: 779**

Calibration Procedure(s): **FF-Z11-002-01**
Calibration Procedure for the Data Acquisition Electronics (DAEx)

Calibration date: **August 14, 2018**

This calibration Certificate documents the traceability to national standards, which realize the physical units of measurements(SI). The measurements and the uncertainties with confidence probability are given on the following pages and are part of the certificate.

All calibrations have been conducted in the closed laboratory facility: environment temperature(22±3)°C and humidity<70%.

Calibration Equipment used (M&TE critical for calibration)

Primary Standards	ID #	Cal Date(Calibrated by, Certificate No.)	Scheduled Calibration
Process Calibrator 753	1971018	20-Jun-18 (CTTL, No.J18X05034)	June-19

	Name	Function	Signature
Calibrated by:	Yu Zongying	SAR Test Engineer	
Reviewed by:	Lin Hao	SAR Test Engineer	
Approved by:	Qi Dianyuan	SAR Project Leader	

Issued: August 15, 2018

This calibration certificate shall not be reproduced except in full without written approval of the laboratory.

Certificate No: Z18-60289

Page 1 of 3



Add: No.51 Xueyuan Road, Haidian District, Beijing, 100191, China
Tel: +86-10-62304633-2512 Fax: +86-10-62304633-2504
E-mail: cttl@chinattl.com Http://www.chinattl.cn

Glossary:

DAE data acquisition electronics
Connector angle information used in DASY system to align probe sensor X to the robot coordinate system.

Methods Applied and Interpretation of Parameters:

- *DC Voltage Measurement:* Calibration Factor assessed for use in DASY system by comparison with a calibrated instrument traceable to national standards. The figure given corresponds to the full scale range of the voltmeter in the respective range.
- *Connector angle:* The angle of the connector is assessed measuring the angle mechanically by a tool inserted. Uncertainty is not required.
- The report provide only calibration results for DAE, it does not contain other performance test results.



Add: No.51 Xueyuan Road, Haidian District, Beijing, 100191, China
 Tel: +86-10-62304633-2512 Fax: +86-10-62304633-2504
 E-mail: cttl@chinattl.com Http://www.chinattl.cn

DC Voltage Measurement

A/D - Converter Resolution nominal
 High Range: 1LSB = 6.1μV , full range = -100...+300 mV
 Low Range: 1LSB = 61nV , full range = -1.....+3mV
 DASY measurement parameters: Auto Zero Time: 3 sec; Measuring time: 3 sec

Calibration Factors	X	Y	Z
High Range	404.118 ± 0.15% (k=2)	403.779 ± 0.15% (k=2)	404.004 ± 0.15% (k=2)
Low Range	3.97198 ± 0.7% (k=2)	3.98234 ± 0.7% (k=2)	3.99816 ± 0.7% (k=2)

Connector Angle

Connector Angle to be used in DASY system	157.5° ± 1 °
---	--------------