



Test report No:

NIE: 46071RRF.004

Test report

REFERENCE STANDARDS:

**FCC 47CFR Part 2.1093, Published RF Exposure KDB Procedures,
 IEEE Std 1528:2013, IEEE Std C95-3:2002,
 IEEE Std C95-1:2005, IC RSS -102 Issue 5:2015**

Identification of item tested.....:	INTEL DUAL BAND WIRELESS – AC 8260
Trade	INTEL
Model and /or type reference	8260D2W
Other identification of the product	FCC ID: PD98260D2 IC ID: 1000M-8260D2
Final HW version	Engineering Sample
Final SW version	--
Features	802.11 a/b/g/n/ac Wireless LAN + BT 4.0
Manufacturer	INTEL MOBILE COMMUNICATIONS 100 Center Point Circle, Suite 200 Columbia, South Carolina 29210 USA
Test method requested, standard.....:	<ol style="list-style-type: none"> 1. FCC 47 CFR Part 2.1093. (10-1-14 Edition) Radiofrequency radiation exposure evaluation: portable devices. 2. IEEE Std. 1528 (2013) – Recommended Practice for Determining the Peak Spatial-Average Specific Absorption Rate (SAR) in the Human Head from Wireless Communications Devices: Measurements Techniques 3. IEEE Std. C95-3 (2002) – IEEE Recommended Practice for Measurement and Computations of Radio Frequency Electromagnetic Fields with Respect to Human Exposure to Such Fields, 100 kHz-300GHz. 4. IEEE Std. C95-1(2005) – IEEE Standard for Safety Levels with Respect to Human Exposure to Radio Frequency Electromagnetic Fields, 3 kHz to 300 GHz. 5. FCC OET KDB 447498 D01 General RF Exposure Guidance v05r02 (February 2014) 6. FCC OET KDB 865664 D01 v01r03 – SAR Measurement Requirements for 100 MHz to 6 GHz (February 2014). 7. FCC OET KDB 248227 D01 802.11 Wi-Fi SAR v02 (March 2015).

	<p>8. IC RSS-102 Issue 5 (2015-03) – Radio Frequency Exposure Compliance of Radiocommunication Apparatus (All Frequency Bands)</p> <p>9. Canada`s Safety Code No.6 – Limits of Human Exposure to Radiofrequency Electromag-netic Fields in the Frequency Range from 3 kHz to 300 GHz</p>
<p>Summary</p>	<p>Considering the results of the performed test according to FCC 47CFR Part 2.1093, the item under test is IN COMPLIANCE with the requested specifications specified in the standards.</p> <p>The maximum 1g volume averaged SAR found during this test has been 0.719 W/kg, at minimum 12 mm separation distance, for 802.11a mode, in the 5.2 GHz frequency band.</p> <p>The maximum 1g volume averaged SAR for MIMO transmission found during this test has been 1.434 W/kg.</p> <p>NOTE: The results presented in this Test Report apply only to the particular item under test established in page 1 of this document, as presented for test on the date(s) shown in section, “USAGE OF SAMPLES, TESTING PERIOD AND ENVIRONMENTAL CONDITIONS”.</p>
<p>Approved by (name / position & signature)</p>	<p>A. Llamas RF Lab. Manager</p>
<p>Date of issue</p>	<p>2015-06-11</p>
<p>Report template No.....</p>	<p>FDT08_16</p>

Index

Competences and guarantees.....	4
General conditions.....	4
Uncertainty	4
Usage of samples.....	5
Test sample description	5
Identification of the client	5
Testing period.....	5
Environmental conditions.....	5
Remarks and comments.....	6
Testing verdicts	7
Appendix A – Test configuration	9
Appendix B – Test results	19
Appendix C – Measurement report	56
Appendix D – System Validation Reports	67
Appendix E – Calibration data	74
Appendix F – Photographs	129

Competences and guarantees

AT4 wireless is a testing laboratory accredited by the National Accreditation Body (ENAC -Entidad Nacional de Acreditación), to perform the tests indicated in the Certificate No. 51/LE 147.

In order to assure the traceability to other national and international laboratories, AT4 wireless has a calibration and maintenance program for its measurement equipment.

AT4 wireless guarantees the reliability of the data presented in this report, which is the result of the measurements and the tests performed to the item under test on the date and under the conditions stated on the report and, it is based on the knowledge and technical facilities available at AT4 wireless at the time of performance of the test.

AT4 wireless is liable to the client for the maintenance of the confidentiality of all information related to the item under test and the results of the test.

The results presented in this Test Report apply only to the particular item under test established in this document.

IMPORTANT: No parts of this report may be reproduced or quoted out of context, in any form or by any means, except in full, without the previous written permission of AT4 wireless.

General conditions

1. This report is only referred to the item that has undergone the test.
2. This report does not constitute or imply on its own an approval of the product by the Certification Bodies or competent Authorities.
3. This document is only valid if complete; no partial reproduction can be made without previous written permission of AT4 wireless.
4. This test report cannot be used partially or in full for publicity and/or promotional purposes without previous written permission of AT4 wireless and the Accreditation Bodies.

Uncertainty

Uncertainty (factor $k=2$) was calculated according to the following documents:

1. FCC OET KDB 865664 D01 - SAR Measurement 100 MHz to 6 GHz (February 2014).

Usage of samples

Samples undergoing test have been selected by: the client

Sample M/01 is composed of the following elements:

Control N°	Description	Model	Serial N°	Date of reception
46071/01	Laptop PC	E5440	JBSYN32	23/04/2015
46071/02	Test Board	8260 Test Board	-	23/04/2015
46071/04	WiFi & BT module	8260 D2W	-	23/04/2015
46071/12	Socket adapter	D2W	-	23/04/2015
46071/13	Reference antenna	SkyCross	Wimax/WLAN	23/04/2015
46071/14	Reference antenna	SkyCross	Wimax/WLAN	23/04/2015

1. Sample M/01 has undergone the test(s) specified in subclause "Test method requested".

Test sample description

The test sample consists of a WiFi & BT module.

Identification of the client

INTEL MOBILE COMMUNICATIONS

100 Center Point Circle, Suite 200

Columbia, South Carolina 29210 USA

Contact person: Steve Hackett

Telephone: Tel: 803-216-2344

e-mail: steven.c.hackett@intel.com

Testing period

The performed test started on 2015-05-15 and finished on 2015-05-28.

The tests have been performed at AT4 wireless.

Environmental conditions

In the laboratory for measurements, the following limits were not exceeded during the test:

Temperature	Min. = 21.15 °C Max. = 24.84 °C
Relative humidity	Min. = 40.90 % Max. = 61.17 %

Remarks and comments

- 1: Testing of other required channels is not required according to FCC OET KDB 447498 D01 General RF Exposure Guidance v05r02, paragraph “4.3.3. SAR test reduction considerations”.
- 2: Testing is not required for this subsequent test configuration according to FCC OET KDB 248227 D01 802.11 Wi-Fi SAR v02, paragraph “5.3.4. Subsequent Test Configuration Procedures”.
- 3: Only the test position with the highest measured SAR for this frequency band has been tested, due to testing reductions mentioned in FCC OET KDB 447498 D01 General RF Exposure Guidance v05r02 (February 2014).
- 4: Only the plots of the highest reported SAR for each test position and mode/band are included in appendix C.

Used instrumentation

1. Dosimetric E-field probes SPEAG ES3DV3 and SPEAG EX3DV4
2. Data acquisition device SPEAG DAE4
3. Electro-optical converter SPEAG EOC3
4. 2450 MHz dipole validation kit SPEAG D2450V2
5. 5000 MHz dipole validation kit SPEAG D5GHzV2
6. Robot Stäubli RX60BL
7. Robot controller Stäubli CM7MB
8. SAR measurement software SPEAG DASY52 V52.8.8.1222
9. SAR post processing software SPEAG SEMCAD X
10. Measurement server SPEAG DASY5 SE UMS 011 BS
11. Oval flat phantom SPEAG ELI 4
12. Body Tissue Equivalent Liquids for 2450MHz and 5GHz bands
13. Vector network analyzer Agilent E5071C.
14. Dielectric probe kit SPEAG DAK-3.5
15. Power meter R&S NRVD and power sensor R&S NRV-Z51
16. RF Generator R&S SMU200A
17. DC Power supply Agilent U8002A
18. Dual directional coupler NARDA FSCM 99899
19. Power amplifier MITEQ AMF-4D-00400600-50-30P
20. Handset positioner SPEAG Device Holder
21. Anritsu MT8852A Bluetooth testing unit.

Testing verdicts

Not applicable	N/A
Pass	P
Fail	F
Not measured	N/M

2450 MHz band

FCC 47CFR Part 2.1093 Paragraph	VERDICT			
	NA	P	F	NM
(d)(2) 802.11b		P		
(d)(2) 802.11g				NM ²
(d)(2) 802.11n		P		
(d)(2) Bluetooth		P		

2: See Remarks and Comments.

5200 MHz band

FCC 47CFR Part 2.1093 Paragraph	VERDICT			
	NA	P	F	NM
(d)(2) 802.11a		P		
(d)(2) 802.11g				NM ²
(d)(2) 802.11n		P		
(d)(2) 802.11ac		P		

2: See Remarks and Comments.

5300 MHz band

FCC 47CFR Part 2.1093 Paragraph	VERDICT			
	NA	P	F	NM
(d)(2) 802.11a		P		
(d)(2) 802.11g				NM ²
(d)(2) 802.11n		P		
(d)(2) 802.11ac		P		

2: See Remarks and Comments.

5500 MHz band

FCC 47CFR Part 2.1093 Paragraph	VERDICT			
	NA	P	F	NM
(d)(2) 802.11a		P		
(d)(2) 802.11g				NM ²
(d)(2) 802.11n		P		
(d)(2) 802.11ac		P		

2: See Remarks and Comments.

5800 MHz band

FCC 47CFR Part 2.1093 Paragraph	VERDICT			
	NA	P	F	NM
(d)(2) 802.11a		P		
(d)(2) 802.11g				NM ²
(d)(2) 802.11n		P		
(d)(2) 802.11ac		P		

2: See Remarks and Comments.

Appendix A – Test configuration

INDEX

1.	GENERAL INTRODUCTION	11
1.1.	Application Standard.....	11
1.2.	General requirements	11
1.3.	Measurement system requirements	11
1.4.	Phantom requirements.....	11
1.5.	Measurement Liquids requirements.....	11
2.	MEASUREMENT SYSTEM.....	12
2.1.	Measurement System	12
2.2.	Test Positions of device relative to body	16
2.3.	Test to be performed	16
2.4.	Description of interpolation/extrapolation scheme	16
2.5.	Determination of the largest peak spatial-average SAR	16
2.6.	System Validation	16
3.	UNCERTAINTY.....	17
4.	SAR LIMIT	18
5.	DEVICE UNDER TEST	18
5.1.	Dimensions.....	18
5.2.	Wireless Technology.....	18
5.3.	Simultaneous Transmission.....	18
5.4.	Antenna Reference Positions	18

1. GENERAL INTRODUCTION

1.1. Application Standard

The Federal Communications Commission (FCC) sets the limits for General Population / Uncontrolled exposure to radio frequency electromagnetic fields for transmitting devices designed to be used within 20 centimetres of the body of the user under FCC 47 CFR Part 2.1093 - “Radiofrequency radiation exposure evaluation: portable devices”, paragraph (d)(2).

1.2. General requirements

The SAR measurement has been performed continuing the following considerations and environment conditions:

- The ambient temperature shall be in the range of 18°C to 25°C and the variation shall not exceed +/- 2°C during the test.
- The ambient humidity shall be in the range of and 30% - 70%.
- The device battery shall be fully charged before each measurement.

1.3. Measurement system requirements

The measurement system used for SAR tests fulfils the procedural and technical requirements described at the reference standards used.

1.4. Phantom requirements

The phantom model for body measurements is an elliptical open-top container with a flat bottom, with the following shape and dimension:

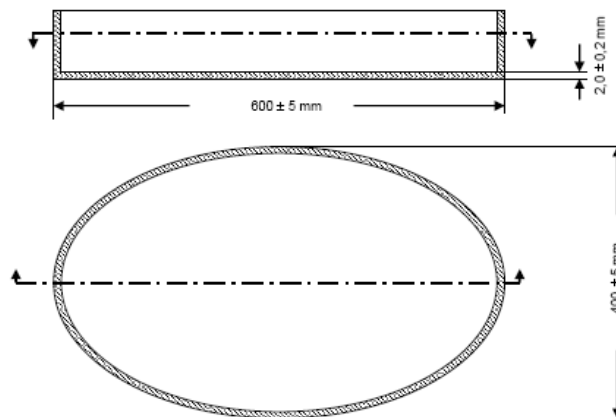

Figure 1: Proportions and shape of Phantom shell

1.5. Measurement Liquids requirements.

The liquids used to simulate the human tissues, must fulfil the requirements of the dielectric properties required. These target dielectric properties per FCC OET KDB 450824 instructions come from the dipole and probe calibration data which are included in Appendix B, Section 3, of this document.

To minimize the effect of reflections on peak spatial-average SAR values, from the upper surface of the tissue-equivalent liquid, the depth of the liquid should be at least 15 cm.

2. MEASUREMENT SYSTEM

2.1. Measurement System

The DASY5 system for performing compliance tests consists of the following items:

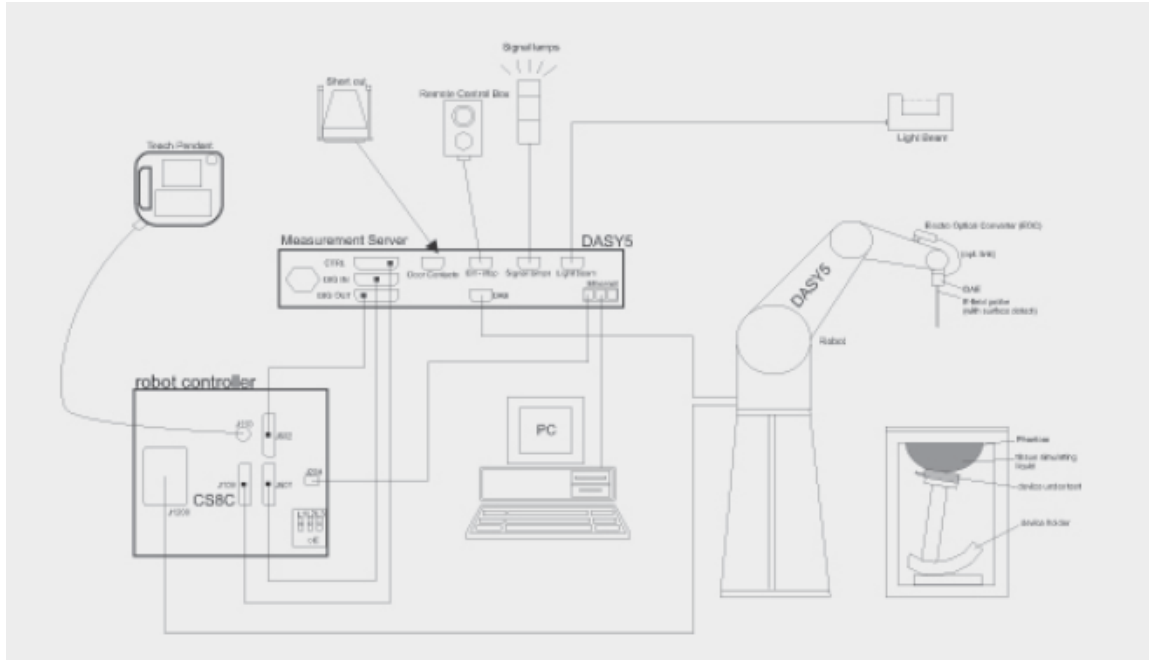



Figure 2: SAR Measurement system

- A standard high precision 6-axis robot (Stäubli TX=RX family) with controller, teach pendant and software. An arm extension for accommodating the data acquisition electronics (DAE).
- An isotropic field probe optimized and calibrated for the targeted measurement.
- A data acquisition electronics (DAE) which performs the signal amplification, signal multiplexing, AD-conversion, offset measurements, mechanical surface detection, collision detection, etc. The unit is battery powered with standard or rechargeable batteries. The signal is optically transmitted to the EOC.
- The Electro-optical converter (EOC) performs the conversion from optical to electrical signals for the digital communication to the DAE. To use optical surface detection, a special version of the EOC is required. The EOC signal is transmitted to the measurement server.
- The function of the measurement server is to perform the time critical tasks such as signal filtering, control of the robot operation and fast movement interrupts.
- The Light Beam used is for probe alignment. This improves the (absolute) accuracy of the probe positioning.
- A computer running Win7 professional operating system and the DASY5 software.
- Remote control and teach pendant as well as additional circuitry for robot safety such as warning lamps, etc.
- The phantom, the device holder and other accessories according to the targeted measurement.

Manufacturer	Device	Type
Schmid & Partner Engineering AG	Dosimetric E-Field Probe	ES3DV3
Schmid & Partner Engineering AG	Dosimetric E-Field Probe	EX3DV4
Schmid & Partner Engineering AG	Data Acquisition Electronics	DAE4
Schmid & Partner Engineering AG	Electro-Optical Converter	EOC3
Stäubli	Robot	RX60BL
Stäubli	Robot controller	CS7MB
Schmid & Partner Engineering AG	Measurement Server	DASY5 SE UMS 011 BS
Schmid & Partner Engineering AG	Oval flat phantom	SPEAG ELI 4
Schmid & Partner Engineering AG	Handset Positioner	SD000 HD1HA
Schmid & Partner Engineering AG	Measurement Software	DASY52 V52.8.8.1222
Schmid & Partner Engineering AG	Postprocessing Software	SEMCAD X
Rohde & Schwarz	RF Generator	SMU 200A
MITEQ	Power amplifier	AMF-4D-00400600-50-30P
Agilent	DC Power supply	U8002A
NARDA	Directional coupler	FSCM 99899
Weinschel	6dB attenuator	75A-6-11
Weinschel	20 dB attenuator	75A-20-11
Rohde & Schwarz	Power Meter & Power Sensor	NRVD & NRV-Z51
Agilent	Power Meter	E4419B
Schmid & Partner Engineering AG	2450 MHz System Validation Dipole	D2450V2
Schmid & Partner Engineering AG	5000 MHz System Validation Dipole	D5GHzV2
Agilent	Vector Network Analyser	E5071C
Schmid & Partner Engineering AG	Dielectric Probe Kit	DAK-3.5

Table 1: Measurement Equipment

DOSIMETRIC E-FIELD PROBE

ES3DV3 Isotropic E-Field Probe for Dosimetric Measurements	
	Symmetrical design with triangular core Interleaved sensors Built-in shielding against static charges PEEK enclosure material (resistant to organic solvents, e.g., DGBE)
Calibration	ISO/IEC 17025
Frequency	10 MHz to 4 GHz; Linearity: ± 0.2 dB (30 MHz to 4 GHz)
Directivity	± 0.2 dB in TSL (rotation around probe axis) ± 0.3 dB in TSL (rotation normal to probe axis)
Dynamic Range	5 μ W/g to > 100 mW/g; Linearity: ± 0.2 dB
Dimensions	Overall length: 337 mm (Tip: 20 mm) Tip diameter: 3.9 mm (Body: 12 mm) Distance from probe tip to dipole centers: 2.0 mm

DOSIMETRIC E-FIELD PROBE

EX3DV4 Smallest Isotropic E-Field Probe for Dosimetric Measurements	
	Symmetrical design with triangular core Built-in shielding against static charges PEEK enclosure material (resistant to organic solvents, e.g., DGBE)
Calibration	ISO/IEC 17025
Frequency	10 MHz to > 6 GHz Linearity: ± 0.2 dB (30 MHz to 6 GHz)
Directivity	± 0.3 dB in TSL (rotation around probe axis) ± 0.5 dB in TSL (rotation normal to probe axis)
Dynamic Range	10 μ W/g to > 100 mW/g Linearity: ± 0.2 dB (noise: typically < 1 μ W/g)
Dimensions	Overall length: 337 mm (Tip: 20 mm) Tip diameter: 2.5 mm (Body: 12 mm) Typical distance from probe tip to dipole centers: 1 mm

DATA ACQUISITION ELECTRONICS

DAE4 - Data Acquisition Electronics	
	Signal amplifier, multiplexer, A/D converter, and control logic Serial optical link for communication with DASY4/5 embedded system (fully remote controlled) Two-step probe touch detector for mechanical surface detection and emergency robot stop
Measurement Range	-100 to +300 mV (16 bit resolution and two range settings: 4mV, 400mV)
Input Offset Voltage	< 5 μ V (with auto zero)
Input Resistance	200 MOhm
Input Bias Current	< 50 fA

OVAL FLAT PHANTOM

ELI	
	<p>Phantom for compliance testing of handheld and body-mounted wireless devices in the frequency range of 30 MHz to 6 GHz. ELI is fully compatible with the IEC 62209-2 standard and all known tissue simulating liquids. ELI has been optimized regarding its performance and can be integrated into our standard phantom tables. A cover prevents evaporation of the liquid. Reference markings on the phantom allow installation of the complete setup, including all predefined phantom positions and measurement grids, by teaching three points. The phantom is compatible with all SPEAG dosimetric probes and dipoles.</p> <p>ELI V5.0 has the same shell geometry and is manufactured from the same material as ELI4, but has reinforced top structure.</p>
Material	Vinylester, glass fiber reinforced (VE-GF)
Liquid Compatibility	Compatible with all SPEAG tissue simulating liquids (incl. DGBE type)
Shell Thickness	2.0 ± 0.2 mm (bottom plate)
Dimensions	Major axis: 600 mm Minor axis: 400 mm
Filling Volume	approx. 30 liters
Wooden Support	SPEAG standard phantom table

HANDSET POSITIONER

	<p>Mounting Device for Hand-Held Transmitters</p> <p>In combination with the Twin SAM V5.0/V5.0c or ELI Phantoms, the Mounting Device for Hand-Held Transmitters enables rotation of the mounted transmitter device to specified spherical coordinates. At the heads, the rotation axis is at the ear opening. Transmitter devices can be easily and accurately positioned according to IEC 62209-1, IEEE 1528, FCC, or other specifications. The device holder can be locked for positioning at different phantom sections (left head, right head, flat).</p> <p>Material: Polyoxymethylene (POM)</p>
--	--

DIPOLES

System Validation Kits 300 MHz – 6 GHz			
	<p>Symmetrical dipole with 1/4 balun Enables measurement of feedpoint impedance with NWA Matched for use near flat phantoms filled with tissue simulating solutions</p>		
Calibration	ISO/IEC 17025		
Frequency	300, 400, 450, 600, 733, 750, 835, 850, 900, 1300, 1450, 1500, 1640, 1750, 1800, 1900, 1950, 2000, 2100, 2300, 2450, 2550, 2600, 3000, 3300, 3500, 3700 MHz and D5GHz (5100-5800 MHz)		
Return Loss	> 20 dB at specified validation position		
Power Capability	> 100 W (f < 1GHz); > 40 W (f > 1GHz)		
Dimensions (length and overall height in mm)	Product	Dipole length	Overall height
	D750V3	179.0	330.0
	D900V2	148.5	340.0
	D1800V2	72.5	300.0
	D2000V2	65.0	300.0
	D2450V2	52.0	290.0
	D2600V2	49.2	290.0
D5GHzV2	20.6	300.0	

2.2. Test Positions of device relative to body

The transmitter was tested using a representative antenna at different orientations relative to the phantom surface, in order to find the orientation with the highest measured SAR value. The test separation distance from the antenna to the phantom surface was 12 mm.

The transmitter was placed more than 15 cm away from the phantom to avoid interferences.

2.3. Test to be performed

Using a host laptop to configure the transmitter, all transmission modes were measured at the reference distance (12 mm) to confirm that the highest measured SAR value was ≤ 0.8 W/kg.

2.4. Description of interpolation/extrapolation scheme

The local SAR inside the Phantom is measured using small dipole sensing elements inside a probe element. The probe tip must not be in contact with the Phantoms surface in order to minimise measurement errors, but the highest local SAR is obtained from measurements at a certain distances from the shell through extrapolation. The accurate assessment of the maximum SAR averaged over 1 gr and 10 gr. requires a very fine resolution in the three dimensional scanned data array. Since the measurements have to be performed over a limited time, the measured data have to be interpolated to provide an array of sufficient resolution.

The interpolation of 2D area scan is used after the initial area scan, at a fixed distance from the Phantom shell wall. The initial scan data is collected with approx. 15 mm spatial resolution and this interpolation is used to find the location of the local maximum for positioning the subsequent 3D scanning within a 1 mm resolution.

For the 3D scan, data is collected on a spatially regular 3D grid having 5 mm steps in both directions. After the data collection by the SAR probe, the data are extrapolated in the depth direction to assign values to points in the 3D array closer to the shell wall. A notional extrapolation value is also assigned to the first point outside the shell wall so that subsequent interpolation schemes will be applicable right up to the shell wall boundary.

2.5. Determination of the largest peak spatial-average SAR

To determine the maximum value of the peak spatial-average SAR of a EUT, all device positions, configurations and operational modes should be tested for each frequency band.

The averaging volume shall be chosen as 1gr. of contiguous tissue. The cubic volumes, over which the SAR measurements are averaged after extrapolation and interpolation, are chosen in order to include the highest values of local SAR.

The maximum SAR level for the EUT will be the maximum level obtained of the performed measurements, and indicated in the previous points.

2.6. System Validation

Prior to the SAR measurements, system verification is done to verify the system accuracy. A complete SAR evaluation is done using a half-wavelength dipole as source with the frequency of the mid-band channel of the operating band, or within 10% of this channel.

The measured 1 gr. and 10 gr. SAR should be within 10% of the expected target values specified in the calibration certificate of the dipole, for the specific tissue and frequency used.

3. UNCERTAINTY

Uncertainty for 300 MHz – 6 GHz

ERROR SOURCES	Uncertainty value (\pm %)	Probability distribution	Divisor	(c_i) 1g	(c_i) 10g	Standard uncertainty (1g) (\pm %)	Standard uncertainty (10g) (\pm %)
Measurement Equipment							
Probe Calibration	6.550	N	1	1	1	6.550	6.550
Isotropy	7.558	R	$\sqrt{3}$	1	1	4.364	4.364
Linearity	4.700	R	$\sqrt{3}$	1	1	2.714	2.714
Probe modulation response	2.300	R	$\sqrt{3}$	1	1	1.328	1.328
Detection limits	0.250	R	$\sqrt{3}$	1	1	0.144	0.144
Boundary effect	2.000	R	$\sqrt{3}$	1	1	1.155	1.155
Readout electronics	0.300	N	1	1	1	0.300	0.300
Response time	0.000	R	$\sqrt{3}$	1	1	0.000	0.000
Integration time	1.900	R	$\sqrt{3}$	1	1	1.097	1.097
RF Ambien conditions - noise	3.000	R	$\sqrt{3}$	1	1	1.732	1.732
RF Ambien conditions – reflections	3.000	R	$\sqrt{3}$	1	1	1.732	1.732
Probe positioner mech. restrictions	0.400	R	$\sqrt{3}$	1	1	0.231	0.231
Probe positioning with respect to phantom shell	6.700	R	$\sqrt{3}$	1	1	3.868	3.868
Post-processing	4.000	R	$\sqrt{3}$	1	1	2.309	2.309
Test Sample Related							
Device holder uncertainty	2.900	N	1	1	1	2.900	2.900
Test sample positioning	3.600	N	1	1	1	3.600	3.600
Drift of output power	5.000	R	$\sqrt{3}$	1	1	2.887	2.887
Phantom and Setup							
Phantom uncertainty (shape and thickness tolerances)	7.900	R	$\sqrt{3}$	1	1	4.561	4.561
Algorithm for correcting SAR for deviations in permittivity and conductivity	1.900	N	1	1	0.84	1.900	1.596
Liquid conductivity (meas.)	3.350	N	1	0.78	0.71	2.613	2.379
Liquid permittivity (meas.)	1.500	N	1	0.23	0.26	0.345	0.390
Liquid conductivity – temperature uncertainty	0.440	R	$\sqrt{3}$	0.78	0.71	0.198	0.180
Liquid permittivity – temperature uncertainty	3.120	R	$\sqrt{3}$	0.23	0.26	0.414	0.468
Combined standard uncertainty	$u_c = \sqrt{\sum_{i=1}^m c_i^2 \cdot u_i^2}$					12.70	12.62
Expanded uncertainty (confidence interval of 95%)	$ue = 2.00 u_c$					25.40	25.23

Table 2: Uncertainty Assessment for 300 MHz - 6 GHz

4. SAR LIMIT

Having a worst case measurement, the SAR limit is valid for general population/uncontrolled exposure.

The SAR values have to be averaged over a mass of 1 gr. (SAR 1 gr.) with the shape of a cube and averaged over a mass of 10 gr (Extremity SAR 10 gr). These levels couldn't exceed the values indicated in the application Standard:

Standard	SAR	SAR Limit (W/Kg)
FCC 47 CFR Part 2.1093 Paragraph (d)(2)	SAR _{1 gr.}	1.6

Table 3: SAR limit

5. DEVICE UNDER TEST

5.1. Dimmensions

Dimmensions	Millimetres
Height x Width x Depth	40.0 x 75.0 x 0.8

Table 4: Antenna dimmensions

5.2. Wireless Technology

Wireless Technology	Frequency Bands	Modes
Wi-Fi	2.4 GHz	- 802.11b/g/n
	5 GHz	- 802.11a/n/ac
Bluetooth	2.4 GHz	- Bluetooth

Table 5: DUT supported modes

5.3. Simultaneous Transmission

RF Exposure Condition	Capable Transmit Configurations (Chain A + Chain B)
Portable transmitter next to the body	Wi-Fi 2.45 GHz + (Wi-Fi 2.45 GHz or BT)
	Wi-Fi 5GHz + (Wi-Fi 5GHz + BT)

Table 6: DUT simultaneous transmission

5.4. Antenna Reference Positions

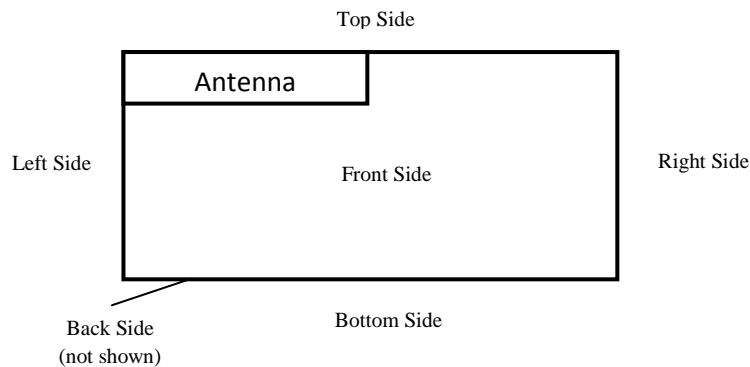

Figure 3: Antenna position against the flat phantom.

Appendix B – Test results

INDEX

1.	TEST CONDITIONS	21
1.1.	Temperature (°C):.....	21
1.2.	Test signal, Output Power and Frequencies	21
1.3.	EUT and test-site configurations.....	21
2.	CONDUCTED AVERAGE POWER MEASUREMENTS.....	22
2.1.	Wi-Fi & Bluetooth	22
3.	TISSUE PARAMETERS MEASUREMENTS	28
4.	SYSTEM CHECK MEASUREMENTS	29
4.1.	Validation results in 2450 MHz Band for Body TSL	29
4.2.	Validation results in 2450 MHz Band for Body TSL	29
4.3.	Validation results in 5200 MHz Band for Body TSL	29
4.4.	Validation results in 5200 MHz Band for Body TSL	29
4.5.	Validation results in 5500 MHz Band for Body TSL	29
4.6.	Validation results in 5800 MHz Band for Body TSL	29
5.	MEASUREMENT RESULTS FOR SAR (SPECIFIC ABSORPTION RATE)	30
5.1.	Summary maximum results for 1g SAR measurements.	30
5.2.	Result for 1g body simultaneous evaluation MIMO.....	30
5.3.	Results for Wi-Fi 2450 MHz Band.	32
5.4.	Results for Wi-Fi 5200 MHz Band.	37
5.5.	Results for Wi-Fi 5300 MHz Band.	41
5.6.	Results for Wi-Fi 5600 MHz Band.	45
5.7.	Results for Wi-Fi 5800 MHz Band.	51
5.8.	Enhanced Energy Coupling.....	55

1. TEST CONDITIONS

1.1. Temperature (°C):

$T_n = +21.15$ to $+24.84$

The subscript n indicates normal test conditions.

1.2. Test signal, Output Power and Frequencies

The device was put into operation by using manufacturer proprietary test mode software (DRTU version 1.8.1.1252). For each channel into the 802.11 modes, the output power of the device was set to transmit at maximum power for all tests (continuous transmission aprox. 100% duty cycle).

The maximum average conducted power of the device was measured with a Power meter R&S NRVD and a thermocoupled Power sensor NRV-Z51.

1.3. EUT and test-site configurations

The device under test was an INTEL 8260D2W module controlled by a host laptop (Dell E5440) computer using a SkyCross Electronics antenna as reference antenna.

The reference antenna was placed with each face against the phantom at 12 mm test separation distance. Measurements have been performed for the highest output power channel per mode, except for those with applicable test reductions, for each supported frequency band.

2. CONDUCTED AVERAGE POWER MEASUREMENTS

2.1. Wi-Fi & Bluetooth

- 2.4 GHz Band SISO:

Band	Mode	Channel / Freq (MHz)	Chain A Averaged Power (dBm)	Chain B Averaged Power (dBm)	
2.4 GHz	802.11b	1 / 2412	21.25	21.06	
		2 / 2417	21.26	21.04	
		3 / 2422	21.05	21.05	
		4 / 2427	21.07	21.06	
		5 / 2432	21.04	21.05	
		6 / 2437	21.20	21.02	
		7 / 2442	21.16	21.08	
		8 / 2447	20.98	21.05	
		9 / 2452	21.16	20.99	
		10 / 2457	21.11	20.78	
		11 / 2462	20.72	18.15	
	802.11g	1 / 2412	19.90	18.38	
		2 / 2417	20.98	20.04	
		3 / 2422	21.02	20.99	
		4 / 2427	21.05	21.24	
		5 / 2432	21.04	21.06	
		6 / 2437	21.01	21.04	
		7 / 2442	20.99	20.58	
		8 / 2447	20.94	20.06	
		9 / 2452	20.68	19.36	
		10 / 2457	19.49	18.56	
		11 / 2462	18.22	17.14	
	802.11n20	1 / 2412	19.10	18.05	
		2 / 2417	20.65	19.96	
		3 / 2422	21.19	20.92	
		4 / 2427	21.22	21.19	
		5 / 2432	21.23	20.98	
		6 / 2437	21.21	20.96	
		7 / 2442	20.67	20.24	
		8 / 2447	20.20	19.96	
		9 / 2452	19.92	18.84	
		10 / 2457	18.67	18.03	
		11 / 2462	17.20	15.91	
	802.11n40	3 / 2422	16.73	14.71	
		4 / 2427	17.17	16.60	
		5 / 2432	19.15	18.13	
		6 / 2437	18.34	17.33	
		7 / 2442	18.04	17.79	
		8 / 2447	17.26	16.41	
			9 / 2452	14.55	14.01

- 2.4 GHz Band MIMO:

Band	Mode	Channel / Freq (MHz)	Chain A Averaged Power (dBm)	Chain B Averaged Power (dBm)
2.4 GHz	802.11n20	1 / 2412	17.34	17.11
		2 / 2417	17.96	18.01
		3 / 2422	18.04	18.09
		4 / 2427	18.01	18.05
		5 / 2432	18.01	18.03
		6 / 2437	18.02	18.03
		7 / 2442	18.12	18.01
		8 / 2447	18.07	17.96
		9 / 2452	18.02	17.92
		10 / 2457	17.97	17.97
		11 / 2462	16.3	16.28
	802.11n40	3 / 2422	14.85	14.56
		4 / 2427	15.48	15.49
		5 / 2432	17.22	17.29
		6 / 2437	17.23	17.26
		7 / 2442	15.45	15.45
		8 / 2447	13.9	13.9
		9 / 2452	16.01	15.84

- Bluetooth:

Band	Mode	Channel	Frequency	Averaged Power (dBm)
2.4 GHz	Bluetooth BR (GFSK)	0	2402	9.34
		39	2441	8.91
		78	2480	9.00
	Bluetooth EDR2 (π 4DQPSK)	0	2402	8.42
		39	2441	8.67
		78	2480	8.51
	Bluetooth EDR3 (8DPSK)	0	2402	8.49
		39	2441	8.98
		78	2480	8.51
	Bluetooth LE	0	2402	6.13
		39	2441	6.09
		78	2480	6.11

- 5.2 GHz Band SISO:

Band	Mode	Channel / Freq (MHz)	Chain A Averaged Power (dBm)	Chain B Averaged Power (dBm)
5.2 GHz	802.11a	36/5180	20.28	19.21
		40/5200	21.08	21.28
		48/5240	21.25	21.39
	802.11n20	36/5180	19.94	18.61
		40/5200	21.32	21.23
		48/5240	21.27	21.34
	802.11n40	38/5190	18.23	17.37
		46/5230	21.22	21.21
	802.11ac80	42/5210	18.48	17.64

- 5.2 GHz Band MIMO:

Band	Mode	Channel / Freq (MHz)	Chain A Averaged Power (dBm)	Chain B Averaged Power (dBm)
5.2 GHz	802.11n20	36/5180	18.19	18.41
		40/5200	18.25	17.99
		48/5240	18.02	17.97
	802.11n40	38/5190	15.76	15.75
		46/5230	18.14	17.83
	802.11ac80	42/5210	14.83	14.95

- 5.3 GHz Bands SISO:

Band	Mode	Channel / Freq (MHz)	Chain A Averaged Power (dBm)	Chain B Averaged Power (dBm)
5.3 GHz	802.11a	52/5260	21.34	21.02
		60/5300	21.33	21.28
		64/5320	18.32	18.47
	802.11n20	52/5260	21.38	21.22
		60/5300	21.32	21.15
		64/5320	18.00	17.68
	802.11n40	54/5270	21.23	21.13
		62/5310	16.45	15.81
	802.11ac80	58/5290	16.25	15.59

- 5.3 GHz Band MIMO:

Band	Mode	Channel / Freq (MHz)	Chain A Averaged Power (dBm)	Chain B Averaged Power (dBm)
5.3 GHz	802.11n20	52/5260	18.25	17.81
		60/5300	18.41	17.99
		64/5320	17.01	17.32
	802.11n40	54/5270	18.24	17.71
		62/5310	14.81	14.62
	802.11ac80	58/5290	13.71	14.12

- 5.6 GHz Band SISO:

Band	Mode	Channel / Freq (MHz)	Chain A Averaged Power (dBm)	Chain B Averaged Power (dBm)
5.6 GHz	802.11a	100/5500	19.39	17.35
		116/5580	21.30	21.36
		140/5700	21.23	21.34
	802.11n20	100/5500	18.39	17.68
		116/5580	21.24	21.29
		140/5700	21.17	21.28
	802.11ac20	144/5720	17.61	17.57
	802.11n40	102/5510	16.53	16.63
		110/5550	21.33	21.15
		134/ 5670	21.25	21.27
	802.11ac40	142/5710	21.19	21.19
	802.11ac80	106/5530	15.34	14.92
138/5690		18.60	18.15	

- 5.6 GHz Band MIMO:

Band	Mode	Channel / Freq (MHz)	Chain A Averaged Power (dBm)	Chain B Averaged Power (dBm)
5.6 GHz	802.11n20	100/5500	17.21	17.74
		116/5580	18.53	17.89
		140/5700	18.68	17.61
	802.11ac20	144/5720	17.02	17.06
	802.11n40	102/5510	16.14	16.08
		110/5550	18.55	18.08
		134/ 5670	18.50	17.72
	802.11ac40	142/5710	17.19	17.53
	802.11ac80	106/5530	11.90	12.33
		138/5690	18.34	18.11

- 5.8 GHz Band SISO:

Band	Mode	Channel / Freq (MHz)	Chain A Averaged Power (dBm)	Chain B Averaged Power (dBm)
5.8 GHz	802.11a	149/5745	20.87	20.62
		157/5785	20.70	20.59
		165/5825	20.56	20.80
	802.11n20	149/5745	20.80	20.54
		157/5785	20.67	20.54
		165/5825	20.81	20.44
	802.11n40	151/5755	20.93	20.73
		159/5795	21.05	20.70
	802.11ac80	155/5775	20.82	20.63

- 5.8 GHz Band MIMO:

Band	Mode	Channel / Freq (MHz)	Chain A Averaged Power (dBm)	Chain B Averaged Power (dBm)
5.8 GHz	802.11n20	149/5745	18.13	18.11
		157/5785	18.06	17.97
		165/5825	18.03	17.96
	802.11n40	151/5755	18.12	18.07
		159/5795	18.28	18.03
	802.11ac80	155/5775	20.79	20.83

3. TISSUE PARAMETERS MEASUREMENTS

Frequency (MHz)	Target Body Tissue: Parameters used in Probe Calibration		Target Body Tissue: Parameters used in Dipole Calibration		Measured Body Tissue		Measured Date
	Permittivity	Conductivity [S/m]	Permittivity	Conductivity [S/m]	Permittivity	Conductivity [S/m]	
2450	52.70 ± 5%	1.95 ± 5%	50.5 ± 6%	2.01 ± 6%	51.61 ± 5%	1.98 ± 5%	20-05-2015
2450	52.70 ± 5%	1.95 ± 5%	50.5 ± 6%	2.01 ± 6%	51.55 ± 5%	1.95 ± 5%	28-05-2015
5200	49.01 ± 5%	5.30 ± 5%	48.9 ± 6%	5.40 ± 6%	50.19 ± 5%	5.17 ± 5%	21-05-2015
5200	49.01 ± 5%	5.30 ± 5%	48.9 ± 6%	5.40 ± 6%	50.37 ± 5%	5.20 ± 5%	25-05-2015
5500	48.61 ± 5%	5.65 ± 5%	48.4 ± 6%	5.79 ± 6%	48.35 ± 5%	5.61 ± 5%	26-05-2015
5800	48.20 ± 5%	6.00 ± 5%	47.9 ± 6%	6.21 ± 6%	47.60 ± 5%	6.20 ± 5%	27-05-2015

Note: The dielectric properties have been measured by the contact probe method at 23° C.

- Composition / Information on ingredients

Muscle Tissue Simulation Liquids HBBL1900-3800V3/M HBBL1900-3800V3

Water	50 – 73 %
Non-ionic detergents	27 – 50 % polyoxyethylenesorbitan monolaurate
NaCl	0 – 2 %
Preservative	0.05 – 0.1% Preventol-D7
Safety relevant ingredients:	
CAS-No. 55965-84-9	< 0.1 % aqueous preparation, containing 5-chloro-2-methyl-3(2H)-isothiazolone and 2-methyl-3(2H)-isothiazolone
CAS-No. 9005-64-5	<50 % polyoxyethylenesorbitan monolaurate

Muscle Tissue Simulation Liquids HBBL5GHzV2

Water	76 – 80 %
Mineral Oil	10 – 12 %
Emulsifiers	8 – 10 %
Additives and Salt	1 – 3%

4. SYSTEM CHECK MEASUREMENTS

4.1. Validation results in 2450 MHz Band for Body TSL

DATE	SAR over	Target SAR	Measured SAR	Drift (%)	± 10% Limit	SAR (W/Kg)
20/05/2015	1 gr.	51.10	48.86	-4.39	√	12.20
	10 gr.	23.90	22.83	-4.49	√	5.70

4.2. Validation results in 2450 MHz Band for Body TSL

DATE	SAR over	Target SAR	Measured SAR	Drift (%)	± 10% Limit	SAR (W/Kg)
28/05/2015	1 gr.	51.10	48.57	-4.96	√	12.10
	10 gr.	23.90	22.56	-5.56	√	5.62

4.3. Validation results in 5200 MHz Band for Body TSL

DATE	SAR over	Target SAR	Measured SAR	Drift (%)	± 10% Limit	SAR (W/Kg)
21/05/2015	1 gr.	74.70	71.43	-4.38	√	7.11
	10 gr.	20.90	20.90	-2.42	√	2.03

4.4. Validation results in 5200 MHz Band for Body TSL

DATE	SAR over	Target SAR	Measured SAR	Drift (%)	± 10% Limit	SAR (W/Kg)
25/05/2015	1 gr.	74.70	72.40	-3.08	√	7.24
	10 gr.	20.90	20.90	-1.44	√	2.06

4.5. Validation results in 5500 MHz Band for Body TSL

DATE	SAR over	Target SAR	Measured SAR	Drift (%)	± 10% Limit	SAR (W/Kg)
26/05/2015	1 gr.	78.70	76.89	-2.30	√	7.68
	10 gr.	21.90	21.42	-2.17	√	2.14

4.6. Validation results in 5800 MHz Band for Body TSL

DATE	SAR over	Target SAR	Measured SAR	Drift (%)	± 10% Limit	SAR (W/Kg)
27/05/2015	1 gr.	75.10	75.44	0.46	√	7.72
	10 gr.	20.80	20.91	0.54	√	2.14

5. MEASUREMENT RESULTS FOR SAR (SPECIFIC ABSORPTION RATE)

5.1. Summary maximum results for 1g SAR measurements.

Band	Mode	Chain / Orientation	Channel (Frequency)	Reported SAR 1g (W/Kg)	SAR limit 1g (W/Kg)
2450 MHz	802.11b	Chain B/ Back side	CH 1 (2412 Mhz)	0.532	1.6
	Bluetooth	Chain B/ Back side	CH 0 (2402 Mhz)	0.027	1.6
5200 MHz	802.11a	Chain B/ Front side	CH 48 (5240 Mhz)	0.625	1.6
5300 MHz	802.11a	Chain A/ Top side	CH 52 (5260 Mhz)	0.719	1.6
5500 MHz	802.11a	Chain B/ Front side	CH 116 (5580 Mhz)	0.663	1.6
5800 MHz	802.11ac80	Chain B/ Front side	CH 155 (5775 MHz)	0.626	1.6

5.2. Result for 1g body simultaneous evaluation MIMO

Transmission Mode	Band	Reported SAR 1g (W/Kg)	Σ SARi (W/kg)	SAR limit 1g (W/Kg)	Verdict
802.11b/Chain A	2450 MHz	0.515	1.047	1.6	Pass
802.11b/Chain B	2450 MHz	0.532			
802.11a/Chain A	5.2GHz	0.614	1.266	1.6	Pass
802.11a/Chain B	5.2GHz	0.625			
Bluetooth	2450 MHz	0.027			
802.11a/Chain A	5.3 GHz	0.719	1.434	1.6	Pass
802.11a/Chain B	5.3 GHz	0.688			
Bluetooth	2450 MHz	0.027			
802.11a/Chain A	5.5 GHz	0.578	1.268	1.6	Pass
802.11a/Chain B	5.5 GHz	0.663			
Bluetooth	2450 MHz	0.027			
802.11ac80/Chain A	5.8 GHz	0.503	1.156	1.6	Pass
802.11ac80/Chain B	5.8 GHz	0.626			
Bluetooth	2450 MHz	0.027			

To calculate the separation ratio the following formula is used:
 $(SAR_1+SAR_2)^{1.5}/R_i$, where R_i is in mm, must be ≤ 0.04

For each of the pairs, the following calculations show the separation ratio at the 50 mm separation stated in the installation guide:

$$2.4 \text{ GHz Band: } (0.515+0.532)^{1.5}/50 = 0.02$$

$$5.2 \text{ GHz Band: } (0.614+0.625+0.027)^{1.5}/50 = 0.03$$

$$5.3 \text{ GHz Band: } (0.719+0.688+0.027)^{1.5}/50 = 0.03$$

$$5.6 \text{ GHz Band: } (0.578+0.663+0.027)^{1.5}/50 = 0.03$$

$$5.8 \text{ GHz Band: } (0.503+0.626+0.027)^{1.5}/50 = 0.02$$

5.3. Results for Wi-Fi 2450 MHz Band.

- 802.11b

Side / Position	Dist (mm)	Mode	Ch #. (Freq)	1-g SAR (W/Kg)	Power Drift (%)	Max Output Power (dBm)	Max. Reported 1-g SAR	Plot No.	
Chain A/ Back side	12	802.11b	CH 1 (2412 Mhz)	0.486	1.98	21.50	0.515	1	
Chain A/ Front side	12	802.11b	CH 1 (2412 Mhz)	0.381	1.27	21.50	0.404		
Chain A/ Top side	12	802.11b	CH 1 (2412 Mhz)	0.226	0	21.50	0.239		
Chain A/ Bottom side	12	802.11b	CH 1 (2412 Mhz)	0.077	1.62	21.50	0.082		
Chain A/ Left side	12	802.11b	CH 1 (2412 Mhz)	0.167	-0.34	21.50	0.177		
Chain A/ Right side	12	802.11b	CH 1 (2412 Mhz)	0.091	1.27	21.50	0.096		
Chain A/ Back side	12	802.11b	CH 6 (2437 Mhz)	NM ¹					
Chain A/ Back side	12	802.11b	CH 11 (2462 Mhz)	NM ¹					

1: See remarks and comments

Side / Position	Dist (mm)	Mode	Ch #. (Freq)	1-g SAR (W/Kg)	Power Drift (%)	Max Output Power (dBm)	Max. Reported 1-g SAR	Plot No.	
Chain B/ Back side	12	802.11b	CH 1 (2412 Mhz)	0.481	0.35	21.50	0.532	2	
Chain B/ Front side	12	802.11b	CH 1 (2412 Mhz)	0.398	-0.80	21.50	0.440		
Chain B/ Top side	12	802.11b	CH 1 (2412 Mhz)	0.216	0.35	21.50	0.239		
Chain B/ Bottom side	12	802.11b	CH 1 (2412 Mhz)	0.071	0	21.50	0.079		
Chain B/ Left side	12	802.11b	CH 1 (2412 Mhz)	0.208	0.81	21.50	0.230		
Chain B/ Right side	12	802.11b	CH 1 (2412 Mhz)	0.062	1.04	21.50	0.069		
Chain B/ Back side	12	802.11b	CH 6 (2437 Mhz)	NM ¹					
Chain B/ Back side	12	802.11b	CH 11 (2462 Mhz)	NM ¹					

1: See remarks and comments

- 802.11g

Side / Position	Dist (mm)	Mode	Ch #. (Freq)	1-g SAR (W/Kg)	Power Drift (%)	Max Output Power (dBm)	Max. Reported 1-g SAR	Plot No.
Chain A/ Back side	12	802.11g	CH 6 (2437 Mhz)			NM ²		
Chain A/ Front side	12	802.11g	CH 6 (2437 Mhz)			NM ²		
Chain A/ Top side	12	802.11g	CH 6 (2437 Mhz)			NM ²		
Chain A/ Bottom side	12	802.11g	CH 6 (2437 Mhz)			NM ²		
Chain A/ Left side	12	802.11g	CH 6 (2437 Mhz)			NM ²		
Chain A/ Right side	12	802.11g	CH 6 (2437 Mhz)			NM ²		

2: See remarks and comments

Side / Position	Dist (mm)	Mode	Ch #. (Freq)	1-g SAR (W/Kg)	Power Drift (%)	Max Output Power (dBm)	Max. Reported 1-g SAR	Plot No.
Chain B/ Back side	12	802.11g	CH 6 (2437 Mhz)			NM ²		
Chain B/ Front side	12	802.11g	CH 6 (2437 Mhz)			NM ²		
Chain B/ Top side	12	802.11g	CH 6 (2437 Mhz)			NM ²		
Chain B/ Bottom side	12	802.11g	CH 6 (2437 Mhz)			NM ²		
Chain B/ Left side	12	802.11g	CH 6 (2437 Mhz)			NM ²		
Chain B/ Right side	12	802.11g	CH 6 (2437 Mhz)			NM ²		

2: See remarks and comments

- 802.11n20

Side / Position	Dist (mm)	Mode	Ch #. (Freq)	1-g SAR (W/Kg)	Power Drift (%)	Max Output Power (dBm)	Max. Reported 1-g SAR	Plot No.
Chain A/ Back side	12	802.11n20	CH 6 (2437 Mhz)				NM ²	
Chain A/ Front side	12	802.11 n20	CH 6 (2437 Mhz)				NM ²	
Chain A/ Top side	12	802.11 n20	CH 6 (2437 Mhz)				NM ²	
Chain A/ Bottom side	12	802.11 n20	CH 6 (2437 Mhz)				NM ²	
Chain A/ Left side	12	802.11 n20	CH 6 (2437 Mhz)				NM ²	
Chain A/ Right side	12	802.11 n20	CH 6 (2437 Mhz)				NM ²	

2: See remarks and comments

Side / Position	Dist (mm)	Mode	Ch #. (Freq)	1-g SAR (W/Kg)	Power Drift (%)	Max Output Power (dBm)	Max. Reported 1-g SAR	Plot No.
Chain B/ Back side	12	802.11n20	CH 6 (2437 Mhz)				NM ²	
Chain B/ Front side	12	802.11 n20	CH 6 (2437 Mhz)				NM ²	
Chain B/ Top side	12	802.11 n20	CH 6 (2437 Mhz)				NM ²	
Chain B/ Bottom side	12	802.11 n20	CH 6 (2437 Mhz)				NM ²	
Chain B/ Left side	12	802.11 n20	CH 6 (2437 Mhz)				NM ²	
Chain B/ Right side	12	802.11 n20	CH 6 (2437 Mhz)				NM ²	

2: See remarks and comments

- 802.11n40

Side / Position	Dist (mm)	Mode	Ch #. (Freq)	1-g SAR (W/Kg)	Power Drift (%)	Max Output Power (dBm)	Max. Reported 1-g SAR	Plot No.	
Chain A/ Back side	12	802.11n40	CH 6 (2437 Mhz)	0.246	-0.34	18.5	0.255		
Chain A/ Front side	12	802.11 n40	CH 6 (2437 Mhz)	NM ³					
Chain A/ Top side	12	802.11 n40	CH 6 (2437 Mhz)	NM ³					
Chain A/ Bottom side	12	802.11 n40	CH 6 (2437 Mhz)	NM ³					
Chain A/ Left side	12	802.11 n40	CH 6 (2437 Mhz)	NM ³					
Chain A/ Right side	12	802.11 n40	CH 6 (2437 Mhz)	NM ³					
Chain A/ Back side	12	802.11 n40	CH 6 (2437 Mhz)	NM ¹					
Chain A/ Back side	12	802.11 n40	CH 6 (2437 Mhz)	NM ¹					

1 and 3: See remarks and comments

Side / Position	Dist (mm)	Mode	Ch #. (Freq)	1-g SAR (W/Kg)	Power Drift (%)	Max Output Power (dBm)	Max. Reported 1-g SAR	Plot No.	
Chain B/ Back side	12	802.11n40	CH 6 (2437 Mhz)	0.201	2.80	17.5	0.209		
Chain B/ Front side	12	802.11 n40	CH 6 (2437 Mhz)	NM ³					
Chain B/ Top side	12	802.11 n40	CH 6 (2437 Mhz)	NM ³					
Chain B/ Bottom side	12	802.11 n40	CH 6 (2437 Mhz)	NM ³					
Chain B/ Left side	12	802.11 n40	CH 6 (2437 Mhz)	NM ³					
Chain B/ Right side	12	802.11 n40	CH 6 (2437 Mhz)	NM ³					
Chain B/ Back side	12	802.11 n40	CH 6 (2437 Mhz)	NM ¹					
Chain B/ Back side	12	802.11 n40	CH 6 (2437 Mhz)	NM ¹					

1 and 3: See remarks and comments

- Bluetooth

Side / Position	Dist (mm)	Mode	Ch #. (Freq)	1-g SAR (W/Kg)	Power Drift (%)	Max Output Power (dBm)	Max. Reported 1-g SAR	Plot No.	
Chain B/ Back side	12	GFSK	CH 0 (2402 Mhz)	0.023	-0.57	10	0.027		
Chain B/ Front side	12	GFSK	CH 0 (2402 Mhz)	0.017	0.12	10	0.02		
Chain B/ Top side	12	GFSK	CH 0 (2402 Mhz)	0.0124	4.83	10	0.014		
Chain B/ Bottom side	12	GFSK	CH 0 (2402 Mhz)	0.0043	-3.62	10	0.005		
Chain B/ Left side	12	GFSK	CH 0 (2402 Mhz)	0.0086	-3.95	10	0.01		
Chain B/ Right side	12	GFSK	CH 0 (2402 Mhz)	0.0025	-0.23	10	0.003		
Chain B/ Back side	12	GFSK	CH 39 (2442 Mhz)	NM ¹					
Chain B/ Back side	12	GFSK	CH 78 (2480 Mhz)	NM ¹					

1: See remarks and comments

5.4. Results for Wi-Fi 5200 MHz Band.

- 802.11a

Side / Position	Dist (mm)	Mode	Ch #. (Freq)	1-g SAR (W/Kg)	Power Drift (%)	Max Output Power (dBm)	Max. Reported 1-g SAR	Plot No.	
Chain A/ Back side	12	802.11a	48 (5240 Mhz)	0.265	0.46	21.50	0.281		
Chain A/ Front side	12	802.11a	48 (5240 Mhz)	0.580	1.39	21.50	0.614	3	
Chain A/ Top side	12	802.11a	48 (5240 Mhz)	0.497	1.39	21.50	0.526		
Chain A/ Bottom side	12	802.11a	48 (5240 Mhz)	0.056	4.11	21.50	0.059		
Chain A/ Left side	12	802.11a	48 (5240 Mhz)	0.106	0.35	21.50	0.112		
Chain A/ Right side	12	802.11a	48 (5240 Mhz)	0.030	2.92	21.50	0.032		
Chain A/ Front side	12	802.11a	36 (5180 Mhz)	NM ¹					
Chain A/ Front side	12	802.11a	40 (5200 Mhz)	NM ¹					

1: See remarks and comments

Side / Position	Dist (mm)	Mode	Ch #. (Freq)	1-g SAR (W/Kg)	Power Drift (%)	Max Output Power (dBm)	Max. Reported 1-g SAR	Plot No.	
Chain B/ Back side	12	802.11a	48 (5240 Mhz)	0.259	0.81	21.50	0.266		
Chain B/ Front side	12	802.11a	48 (5240 Mhz)	0.609	0.93	21.50	0.625	4	
Chain B/ Top side	12	802.11a	48 (5240 Mhz)	0.606	1.51	21.50	0.622		
Chain B/ Bottom side	12	802.11a	48 (5240 Mhz)	0.090	-0.80	21.50	0.092		
Chain B/ Left side	12	802.11a	48 (5240 Mhz)	0.109	0.93	21.50	0.112		
Chain B/ Right side	12	802.11a	48 (5240 Mhz)	0.031	-0.23	21.50	0.032		
Chain B/ Front side	12	802.11a	36 (5180 Mhz)	NM ¹					
Chain B/ Front side	12	802.11a	40 (5200 Mhz)	NM ¹					

1: See remarks and comments

- 802.11n20

Side / Position	Dist (mm)	Mode	Ch #. (Freq)	1-g SAR (W/Kg)	Power Drift (%)	Max Output Power (dBm)	Max. Reported 1-g SAR	Plot No.
Chain A/ Back side	12	802.11n20	40 (5200 Mhz)			NM ²		
Chain A/ Front side	12	802.11n20	40 (5200 Mhz)			NM ²		
Chain A/ Top side	12	802.11n20	40 (5200 Mhz)			NM ²		
Chain A/ Bottom side	12	802.11n20	40 (5200 Mhz)			NM ²		
Chain A/ Left side	12	802.11n20	40 (5200 Mhz)			NM ²		
Chain A/ Right side	12	802.11n20	40 (5200 Mhz)			NM ²		

2: See remarks and comments

Side / Position	Dist (mm)	Mode	Ch #. (Freq)	1-g SAR (W/Kg)	Power Drift (%)	Max Output Power (dBm)	Max. Reported 1-g SAR	Plot No.
Chain B/ Back side	12	802.11n20	48 (5240 Mhz)			NM ²		
Chain B/ Front side	12	802.11n20	48 (5240 Mhz)			NM ²		
Chain B/ Top side	12	802.11n20	48 (5240 Mhz)			NM ²		
Chain B/ Bottom side	12	802.11n20	48 (5240 Mhz)			NM ²		
Chain B/ Left side	12	802.11n20	48 (5240 Mhz)			NM ²		
Chain B/ Right side	12	802.11n20	48 (5240 Mhz)			NM ²		

2: See remarks and comments

- 802.11n40

Side / Position	Dist (mm)	Mode	Ch #. (Freq)	1-g SAR (W/Kg)	Power Drift (%)	Max Output Power (dBm)	Max. Reported 1-g SAR	Plot No.
Chain A/ Back side	12	802.11n40	46 (5230 Mhz)	NM ³				
Chain A/ Front side	12	802.11n40	46 (5230 Mhz)	0.573	0.12	21.50	0.611	
Chain A/ Top side	12	802.11n40	46 (5230 Mhz)	NM ³				
Chain A/ Bottom side	12	802.11n40	46 (5230 Mhz)	NM ³				
Chain A/ Left side	12	802.11n40	46 (5230 Mhz)	NM ³				
Chain A/ Right side	12	802.11n40	46 (5230 Mhz)	NM ³				
Chain A/ Front side	12	802.11n40	38 (5190 Mhz)	NM ¹				

1 and 3: See remarks and comments

Side / Position	Dist (mm)	Mode	Ch #. (Freq)	1-g SAR (W/Kg)	Power Drift (%)	Max Output Power (dBm)	Max. Reported 1-g SAR	Plot No.
Chain B/ Back side	12	802.11n40	46 (5230 Mhz)	NM ³				
Chain B/ Front side	12	802.11n40	46 (5230 Mhz)	0.575	1.98	21.50	0.615	
Chain B/ Top side	12	802.11n40	46 (5230 Mhz)	NM ³				
Chain B/ Bottom side	12	802.11n40	46 (5230 Mhz)	NM ³				
Chain B/ Left side	12	802.11n40	46 (5230 Mhz)	NM ³				
Chain B/ Right side	12	802.11n40	46 (5230 Mhz)	NM ³				
Chain B/ Front side	12	802.11n40	38 (5190 Mhz)	NM ¹				

1 and 3: See remarks and comments

- 802.11ac80

Side / Position	Dist (mm)	Mode	Ch #. (Freq)	1-g SAR (W/Kg)	Power Drift (%)	Max Output Power (dBm)	Max. Reported 1-g SAR	Plot No.	
Chain A/ Back side	12	802.11ac80	42 (5210 Mhz)	NM ³					
Chain A/ Front side	12	802.11ac80	42 (5210 Mhz)	0.317	1.74	18.50	0.318		
Chain A/ Top side	12	802.11ac80	42 (5210 Mhz)	NM ³					
Chain A/ Bottom side	12	802.11ac80	42 (5210 Mhz)	NM ³					
Chain A/ Left side	12	802.11ac80	42 (5210 Mhz)	NM ³					
Chain A/ Right side	12	802.11ac80	42 (5210 Mhz)	NM ³					

3: See remarks and comments

Side / Position	Dist (mm)	Mode	Ch #. (Freq)	1-g SAR (W/Kg)	Power Drift (%)	Max Output Power (dBm)	Max. Reported 1-g SAR	Plot No.	
Chain B/ Back side	12	802.11ac80	42 (5210 Mhz)	NM ³					
Chain B/ Front side	12	802.11ac80	42 (5210 Mhz)	0.277	0.0	18	0.301		
Chain B/ Top side	12	802.11ac80	42 (5210 Mhz)	NM ³					
Chain B/ Bottom side	12	802.11ac80	42 (5210 Mhz)	NM ³					
Chain B/ Left side	12	802.11ac80	42 (5210 Mhz)	NM ³					
Chain B/ Right side	12	802.11ac80	42 (5210 Mhz)	NM ³					

3: See remarks and comments

5.5. Results for Wi-Fi 5300 MHz Band.

- 802.11a

Side / Position	Dist (mm)	Mode	Ch #. (Freq)	1-g SAR (W/Kg)	Power Drift (%)	Max Output Power (dBm)	Max. Reported 1-g SAR	Plot No.	
Chain A/ Back side	12	802.11a	52 (5260 Mhz)	0.311	-0.57	21.50	0.323		
Chain A/ Front side	12	802.11a	52 (5260 Mhz)	0.674	1.16	21.50	0.699		
Chain A/ Top side	12	802.11a	52 (5260 Mhz)	0.693	1.27	21.50	0.719	5	
Chain A/ Bottom side	12	802.11a	52 (5260 Mhz)	0.086	2.45	21.50	0.089		
Chain A/ Left side	12	802.11a	52 (5260 Mhz)	0.1	2.68	21.50	0.104		
Chain A/ Right side	12	802.11a	52 (5260 Mhz)	0.03	2.92	21.50	0.031		
Chain A/ Top side	12	802.11a	60 (5300 Mhz)	NM ¹					
Chain A/ Top side	12	802.11a	64 (5320 Mhz)	NM ¹					

1: See remarks and comments

Side / Position	Dist (mm)	Mode	Ch #. (Freq)	1-g SAR (W/Kg)	Power Drift (%)	Max Output Power (dBm)	Max. Reported 1-g SAR	Plot No.	
Chain B/ Back side	12	802.11a	60 (5300 Mhz)	0.287	0.23	21.50	0.302		
Chain B/ Front side	12	802.11a	60 (5300 Mhz)	0.648	1.74	21.50	0.682		
Chain B/ Top side	12	802.11a	60 (5300 Mhz)	0.517	1.51	21.50	0.544		
Chain B/ Bottom side	12	802.11a	60 (5300 Mhz)	0.066	1.74	21.50	0.069		
Chain B/ Left side	12	802.11a	60 (5300 Mhz)	0.1	-0.46	21.50	0.105		
Chain B/ Right side	12	802.11a	60 (5300 Mhz)	0.035	2.80	21.50	0.037		
Chain B/ Front side	12	802.11a	52 (5260 Mhz)	NM ¹					
Chain B/ Front side	12	802.11a	64 (5320 Mhz)	NM ¹					

1: See remarks and comments

- 802.11n20

Side / Position	Dist (mm)	Mode	Ch #. (Freq)	1-g SAR (W/Kg)	Power Drift (%)	Max Output Power (dBm)	Max. Reported 1-g SAR	Plot No.
Chain A/ Back side	12	802.11n20	52 (5260 Mhz)			NM ²		
Chain A/ Front side	12	802.11n20	52 (5260 Mhz)			NM ²		
Chain A/ Top side	12	8802.11n20	52 (5260 Mhz)			NM ²		
Chain A/ Bottom side	12	802.11n20	52 (5260 Mhz)			NM ²		
Chain A/ Left side	12	802.11n20	52 (5260 Mhz)			NM ²		
Chain A/ Right side	12	802.11n20	52 (5260 Mhz)			NM ²		

2: See remarks and comments

Side / Position	Dist (mm)	Mode	Ch #. (Freq)	1-g SAR (W/Kg)	Power Drift (%)	Max Output Power (dBm)	Max. Reported 1-g SAR	Plot No.
Chain B/ Back side	12	802.11n20	52 (5260 Mhz)			NM ²		
Chain B/ Front side	12	802.11n20	52 (5260 Mhz)			NM ²		
Chain B/ Top side	12	8802.11n20	52 (5260 Mhz)			NM ²		
Chain B/ Bottom side	12	802.11n20	52 (5260 Mhz)			NM ²		
Chain B/ Left side	12	802.11n20	52 (5260 Mhz)			NM ²		
Chain B/ Right side	12	802.11n20	52 (5260 Mhz)			NM ²		

2: See remarks and comments

- 802.11n40

Side / Position	Dist (mm)	Mode	Ch #. (Freq)	1-g SAR (W/Kg)	Power Drift (%)	Max Output Power (dBm)	Max. Reported 1-g SAR	Plot No.
Chain A/ Back side	12	802.11n40	54 (5270 Mhz)	NM ³				
Chain A/ Front side	12	802.11n40	54 (5270 Mhz)	NM ³				
Chain A/ Top side	12	802.11n40	54 (5270 Mhz)	0.578	1.86	21.50	0.615	
Chain A/ Bottom side	12	802.11n40	54 (5270 Mhz)	NM ³				
Chain A/ Left side	12	802.11n40	54 (5270 Mhz)	NM ³				
Chain A/ Right side	12	802.11n40	54 (5270 Mhz)	NM ³				
Chain A/ Top side	12	802.11n40	62 (5310 Mhz)	NM ¹				

1 and 3: See remarks and comments

Side / Position	Dist (mm)	Mode	Ch #. (Freq)	1-g SAR (W/Kg)	Power Drift (%)	Max Output Power (dBm)	Max. Reported 1-g SAR	Plot No.
Chain B/ Back side	12	802.11n40	54 (5270 Mhz)	NM ³				
Chain B/ Front side	12	802.11n40	54 (5270 Mhz)	0.632	1.04	21.50	0.688	6
Chain B/ Top side	12	802.11n40	54 (5270 Mhz)	NM ³				
Chain B/ Bottom side	12	802.11n40	54 (5270 Mhz)	NM ³				
Chain B/ Left side	12	802.11n40	54 (5270 Mhz)	NM ³				
Chain B/ Right side	12	802.11n40	54 (5270 Mhz)	NM ³				
Chain B/ Front side	12	802.11n40	62 (5310 Mhz)	NM ¹				

1 and 3: See remarks and comments

- 802.11ac80

Side / Position	Dist (mm)	Mode	Ch #. (Freq)	1-g SAR (W/Kg)	Power Drift (%)	Max Output Power (dBm)	Max. Reported 1-g SAR	Plot No.	
Chain A/ Back side	12	802.11ac80	58 (5290 Mhz)	NM ²					
Chain A/ Front side	12	802.11ac80	58 (5290 Mhz)	NM ²					
Chain A/ Top side	12	802.11ac80	58 (5290 Mhz)	0.166	0.12	16.50	0.176		
Chain A/ Bottom side	12	802.11ac80	58 (5290 Mhz)	NM ²					
Chain A/ Left side	12	802.11ac80	58 (5290 Mhz)	NM ²					
Chain A/ Right side	12	802.11ac80	58 (5290 Mhz)	NM ²					

2: See remarks and comments

Side / Position	Dist (mm)	Mode	Ch #. (Freq)	1-g SAR (W/Kg)	Power Drift (%)	Max Output Power (dBm)	Max. Reported 1-g SAR	Plot No.	
Chain B/ Back side	12	802.11ac80	58 (5290 Mhz)	NM ²					
Chain B/ Front side	12	802.11ac80	58 (5290 Mhz)	0.15	1.86	16	0.165		
Chain B/ Top side	12	802.11ac80	58 (5290 Mhz)	NM ²					
Chain B/ Bottom side	12	802.11ac80	58 (5290 Mhz)	NM ²					
Chain B/ Left side	12	802.11ac80	58 (5290 Mhz)	NM ²					
Chain B/ Right side	12	802.11ac80	58 (5290 Mhz)	NM ²					

2: See remarks and comments

5.6. Results for Wi-Fi 5600 MHz Band.

- 802.11a

Side / Position	Dist (mm)	Mode	Ch #. (Freq)	1-g SAR (W/Kg)	Power Drift (%)	Max Output Power (dBm)	Max. Reported 1-g SAR	Plot No.	
Chain A/ Back side	12	802.11a	116 (5580 Mhz)	0.354	1.39	21.50	0.371		
Chain A/ Front side	12	802.11a	116 (5580 Mhz)	0.552	1.62	21.50	0.578	7	
Chain A/ Top side	12	802.11a	116 (5580 Mhz)	0.304	3.87	21.50	0.318		
Chain A/ Bottom side	12	802.11a	116 (5580 Mhz)	0.073	4.71	21.50	0.076		
Chain A/ Left side	12	802.11a	116 (5580 Mhz)	0.097	1.04	21.50	0.102		
Chain A/ Right side	12	802.11a	116 (5580 Mhz)	0.019	3.04	21.50	0.02		
Chain A/ Front side	12	802.11a	100 (5500 Mhz)	NM ¹					
Chain A/ Front side	12	802.11a	140 (5700 Mhz)	NM ¹					

1: See remarks and comments

Side / Position	Dist (mm)	Mode	Ch #. (Freq)	1-g SAR (W/Kg)	Power Drift (%)	Max Output Power (dBm)	Max. Reported 1-g SAR	Plot No.	
Chain B/ Back side	12	802.11a	116 (5580 Mhz)	0.344	0.12	21.50	0.355		
Chain B/ Front side	12	802.11a	116 (5580 Mhz)	0.642	-0.34	21.50	0.663	8	
Chain B/ Top side	12	802.11a	116 (5580 Mhz)	0.338	2.45	21.50	0.349		
Chain B/ Bottom side	12	802.11a	116 (5580 Mhz)	0.067	0.46	21.50	0.069		
Chain B/ Left side	12	802.11a	116 (5580 Mhz)	0.187	-1.26	21.50	0.193		
Chain B/ Right side	12	802.11a	116 (5580 Mhz)	0.032	-0.57	21.50	0.033		
Chain B/ Front side	12	802.11a	100 (5500 Mhz)	NM ¹					
Chain B/ Front side	12	802.11a	140 (5700 Mhz)	NM ¹					

1: See remarks and comments

- 802.11n20

Side / Position	Dist (mm)	Mode	Ch #. (Freq)	1-g SAR (W/Kg)	Power Drift (%)	Max Output Power (dBm)	Max. Reported 1-g SAR	Plot No.
Chain A/ Back side	12	802.11n20	116 (5580 Mhz)			NM ²		
Chain A/ Front side	12	802.11n20	116 (5580 Mhz)			NM ²		
Chain A/ Top side	12	802.11n20	116 (5580 Mhz)			NM ²		
Chain A/ Bottom side	12	802.11n20	116 (5580 Mhz)			NM ²		
Chain A/ Left side	12	802.11n20	116 (5580 Mhz)			NM ²		
Chain A/ Right side	12	802.11n20	116 (5580 Mhz)			NM ²		

2: See remarks and comments

Side / Position	Dist (mm)	Mode	Ch #. (Freq)	1-g SAR (W/Kg)	Power Drift (%)	Max Output Power (dBm)	Max. Reported 1-g SAR	Plot No.
Chain B/ Back side	12	802.11n20	116 (5580 Mhz)			NM ²		
Chain B/ Front side	12	802.11n20	116 (5580 Mhz)			NM ²		
Chain B/ Top side	12	802.11n20	116 (5580 Mhz)			NM ²		
Chain B/ Bottom side	12	802.11n20	116 (5580 Mhz)			NM ²		
Chain B/ Left side	12	802.11n20	116 (5580 Mhz)			NM ²		
Chain B/ Right side	12	802.11n20	116 (5580 Mhz)			NM ²		

2: See remarks and comments

- 802.11ac20

Side / Position	Dist (mm)	Mode	Ch #. (Freq)	1-g SAR (W/Kg)	Power Drift (%)	Max Output Power (dBm)	Max. Reported 1-g SAR	Plot No.
Chain A/ Back side	12	802.11ac20	144 (5720 Mhz)			NM ²		
Chain A/ Front side	12	802.11ac20	144 (5720 Mhz)			NM ²		
Chain A/ Top side	12	802.11ac20	144 (5720 Mhz)			NM ²		
Chain A/ Bottom side	12	802.11ac20	144 (5720 Mhz)			NM ²		
Chain A/ Left side	12	802.11ac20	144 (5720 Mhz)			NM ²		
Chain A/ Right side	12	802.11ac20	144 (5720 Mhz)			NM ²		

2: See remarks and comments

Side / Position	Dist (mm)	Mode	Ch #. (Freq)	1-g SAR (W/Kg)	Power Drift (%)	Max Output Power (dBm)	Max. Reported 1-g SAR	Plot No.
Chain B/ Back side	12	802.11ac20	144 (5720 Mhz)			NM ²		
Chain B/ Front side	12	802.11ac20	144 (5720 Mhz)			NM ²		
Chain B/ Top side	12	802.11ac20	144 (5720 Mhz)			NM ²		
Chain B/ Bottom side	12	802.11ac20	144 (5720 Mhz)			NM ²		
Chain B/ Left side	12	802.11ac20	144 (5720 Mhz)			NM ²		
Chain B/ Right side	12	802.11ac20	144 (5720 Mhz)			NM ²		

2: See remarks and comments

- 802.11n40

Side / Position	Dist (mm)	Mode	Ch #. (Freq)	1-g SAR (W/Kg)	Power Drift (%)	Max Output Power (dBm)	Max. Reported 1-g SAR	Plot No.
Chain A/ Back side	12	802.11n40	110 (5550 Mhz)	NM ³				
Chain A/ Front side	12	802.11n40	110 (5550 Mhz)	0.567	1.39	21.50	0.590	
Chain A/ Top side	12	802.11n40	110 (5550 Mhz)	NM ³				
Chain A/ Bottom side	12	802.11n40	110 (5550 Mhz)	NM ³				
Chain A/ Left side	12	802.11n40	110 (5550 Mhz)	NM ³				
Chain A/ Right side	12	802.11n40	110 (5550 Mhz)	NM ³				
Chain A/ Front side	12	802.11n40	102 (5510 Mhz)	NM ¹				
Chain A/ Front side	12	802.11n40	134 (5670 Mhz)	NM ¹				

1 and 3: See remarks and comments

Side / Position	Dist (mm)	Mode	Ch #. (Freq)	1-g SAR (W/Kg)	Power Drift (%)	Max Output Power (dBm)	Max. Reported 1-g SAR	Plot No.
Chain B/ Back side	12	802.11n40	134 (5670 Mhz)	NM ³				
Chain B/ Front side	12	802.11n40	134 (5670 Mhz)	0.477	0	21.50	0.503	
Chain B/ Top side	12	802.11n40	134 (5670 Mhz)	NM ³				
Chain B/ Bottom side	12	802.11n40	134 (5670 Mhz)	NM ³				
Chain B/ Left side	12	802.11n40	134 (5670 Mhz)	NM ³				
Chain B/ Right side	12	802.11n40	134 (5670 Mhz)	NM ³				
Chain B/ Front side	12	802.11n40	102 (5510 Mhz)	NM ¹				
Chain B/ Front side	12	802.11n40	110 (5550 Mhz)	NM ¹				

1 and 3: See remarks and comments

- 802.11ac40

Side / Position	Dist (mm)	Mode	Ch #. (Freq)	1-g SAR (W/Kg)	Power Drift (%)	Max Output Power (dBm)	Max. Reported 1-g SAR	Plot No.
Chain A/ Back side	12	802.11ac40	142 (5710 Mhz)			NM ²		
Chain A/ Front side	12	802.11ac40	142 (5710 Mhz)			NM ²		
Chain A/ Top side	12	802.11ac40	142 (5710 Mhz)			NM ²		
Chain A/ Bottom side	12	802.11ac40	142 (5710 Mhz)			NM ²		
Chain A/ Left side	12	802.11ac40	142 (5710 Mhz)			NM ²		
Chain A/ Right side	12	802.11ac40	142 (5710 Mhz)			NM ²		

2: See remarks and comments

Side / Position	Dist (mm)	Mode	Ch #. (Freq)	1-g SAR (W/Kg)	Power Drift (%)	Max Output Power (dBm)	Max. Reported 1-g SAR	Plot No.
Chain B/ Back side	12	802.11ac40	142 (5710 Mhz)			NM ²		
Chain B/ Front side	12	802.11ac40	142 (5710 Mhz)			NM ²		
Chain B/ Top side	12	802.11ac40	142 (5710 Mhz)			NM ²		
Chain B/ Bottom side	12	802.11ac40	142 (5710 Mhz)			NM ²		
Chain B/ Left side	12	802.11ac40	142 (5710 Mhz)			NM ²		
Chain B/ Right side	12	802.11ac40	142 (5710 Mhz)			NM ²		

2: See remarks and comments

- 802.11ac80

Side / Position	Dist (mm)	Mode	Ch #. (Freq)	1-g SAR (W/Kg)	Power Drift (%)	Max Output Power (dBm)	Max. Reported 1-g SAR	Plot No.	
Chain A/ Back side	12	802.11ac80	138 (5690 Mhz)	NM ³					
Chain A/ Front side	12	802.11ac80	138 (5690 Mhz)	0.317	3.28	19	0.348		
Chain A/ Top side	12	802.11ac80	138 (5690 Mhz)	NM ³					
Chain A/ Bottom side	12	802.11ac80	138 (5690 Mhz)	NM ³					
Chain A/ Left side	12	802.11ac80	138 (5690 Mhz)	NM ³					
Chain A/ Right side	12	802.11ac80	138 (5690 Mhz)	NM ³					
Chain A/ Front side	12	802.11ac80	106 (5530 Mhz)	NM ¹					

1 and 3: See remarks and comments

Side / Position	Dist (mm)	Mode	Ch #. (Freq)	1-g SAR (W/Kg)	Power Drift (%)	Max Output Power (dBm)	Max. Reported 1-g SAR	Plot No.	
Chain B/ Back side	12	802.11ac80	138 (5690 Mhz)	NM ³					
Chain B/ Front side	12	802.11ac80	138 (5690 Mhz)	0.317	1.04	18.50	0.344		
Chain B/ Top side	12	802.11ac80	138 (5690 Mhz)	NM ³					
Chain B/ Bottom side	12	802.11ac80	138 (5690 Mhz)	NM ³					
Chain B/ Left side	12	802.11ac80	138 (5690 Mhz)	NM ³					
Chain B/ Right side	12	802.11ac80	138 (5690 Mhz)	NM ³					
Chain B/ Front side	12	802.11ac80	106 (5530 Mhz)	NM ¹					

1 and 2: See remarks and comments

5.7. Results for Wi-Fi 5800 MHz Band.

- 802.11a

Side / Position	Dist (mm)	Mode	Ch #. (Freq)	1-g SAR (W/Kg)	Power Drift (%)	Max Output Power (dBm)	Max. Reported 1-g SAR	Plot No.	
Chain A/ Back side	12	802.11a	149 (5745 Mhz)	0.352	2.57	21	0.363		
Chain A/ Front side	12	802.11a	149 (5745 Mhz)	0.215	1.74	21	0.222		
Chain A/ Top side	12	802.11a	149 (5745 Mhz)	0.267	0.46	21	0.275		
Chain A/ Bottom side	12	802.11a	149 (5745 Mhz)	0.038	1.27	21	0.039		
Chain A/ Left side	12	802.11a	149 (5745 Mhz)	0.089	1.39	21	0.092		
Chain A/ Right side	12	802.11a	149 (5745 Mhz)	0.021	-2.28	21	0.022		
Chain A/ Front side	12	802.11a	157 (5785 Mhz)	NM ¹					
Chain A/ Front side	12	802.11a	165 (5825 Mhz)	NM ¹					

1: See remarks and comments

Side / Position	Dist (mm)	Mode	Ch #. (Freq)	1-g SAR (W/Kg)	Power Drift (%)	Max Output Power (dBm)	Max. Reported 1-g SAR	Plot No.	
Chain B/ Back side	12	802.11a	165 (5825 Mhz)	0.231	0.81	21	0.242		
Chain B/ Front side	12	802.11a	165 (5825 Mhz)	0.499	2.68	21	0.523		
Chain B/ Top side	12	802.11a	165 (5825 Mhz)	0.419	1.74	21	0.439		
Chain B/ Bottom side	12	802.11a	165 (5825 Mhz)	0.038	1.27	21	0.040		
Chain B/ Left side	12	802.11a	165 (5825 Mhz)	0.107	-0.80	21	0.112		
Chain B/ Right side	12	802.11a	165 (5825 Mhz)	0.021	-0.57	21	0.022		
Chain B/ Front side	12	802.11a	149 (5745 Mhz)	NM ¹					
Chain B/ Front side	12	802.11a	157 (5785 Mhz)	NM ¹					

1: See remarks and comments

- 802.11n20

Side / Position	Dist (mm)	Mode	Ch #. (Freq)	1-g SAR (W/Kg)	Power Drift (%)	Max Output Power (dBm)	Max. Reported 1-g SAR	Plot No.
Chain A/ Back side	12	802.11n20	165 (5825 Mhz)			NM ²		
Chain A/ Front side	12	802.11n20	165 (5825 Mhz)			NM ²		
Chain A/ Top side	12	802.11n20	165 (5825 Mhz)			NM ²		
Chain A/ Bottom side	12	802.11n20	165 (5825 Mhz)			NM ²		
Chain A/ Left side	12	802.11n20	165 (5825 Mhz)			NM ²		
Chain A/ Right side	12	802.11n20	165 (5825 Mhz)			NM ²		
Chain A/ Front side	12	802.11n20	149 (5745 Mhz)			NM ¹		
Chain A/ Front side	12	802.11n20	157 (5785 Mhz)			NM ¹		

1 and 2: See remarks and comments

Side / Position	Dist (mm)	Mode	Ch #. (Freq)	1-g SAR (W/Kg)	Power Drift (%)	Max Output Power (dBm)	Max. Reported 1-g SAR	Plot No.
Chain B/ Back side	12	802.11n20	157 (5785 Mhz)			NM ²		
Chain B/ Front side	12	802.11n20	157 (5785 Mhz)			NM ²		
Chain B/ Top side	12	802.11n20	157 (5785 Mhz)			NM ²		
Chain B/ Bottom side	12	802.11n20	157 (5785 Mhz)			NM ²		
Chain B/ Left side	12	802.11n20	157 (5785 Mhz)			NM ²		
Chain B/ Right side	12	802.11n20	157 (5785 Mhz)			NM ²		
Chain B/ Front side	12	802.11n20	149 (5745 Mhz)			NM ¹		
Chain B/ Front side	12	802.11n20	165 (5825 Mhz)			NM ¹		

1 and 2: See remarks and comments

- 802.11n40

Side / Position	Dist (mm)	Mode	Ch #. (Freq)	1-g SAR (W/Kg)	Power Drift (%)	Max Output Power (dBm)	Max. Reported 1-g SAR	Plot No.
Chain A/ Back side	12	802.11n40	159 (5795 Mhz)	NM ³				
Chain A/ Front side	12	802.11n40	159 (5795 Mhz)	0.483	0.46	21	0.483	
Chain A/ Top side	12	802.11n40	159 (5795 Mhz)	NM ³				
Chain A/ Bottom side	12	802.11n40	159 (5795 Mhz)	NM ³				
Chain A/ Left side	12	802.11n40	159 (5795 Mhz)	NM ³				
Chain A/ Right side	12	802.11n40	159 (5795 Mhz)	NM ³				
Chain A/ Front side	12	802.11n40	151 (5755 Mhz)	NM ¹				

1 and 3: See remarks and comments

Side / Position	Dist (mm)	Mode	Ch #. (Freq)	1-g SAR (W/Kg)	Power Drift (%)	Max Output Power (dBm)	Max. Reported 1-g SAR	Plot No.
Chain B/ Back side	12	802.11n40	151 (5755 Mhz)	NM ³				
Chain B/ Front side	12	802.11n40	151 (5755 Mhz)	0.446	2.21	21	0.475	
Chain B/ Top side	12	802.11n40	151 (5755 Mhz)	NM ³				
Chain B/ Bottom side	12	802.11n40	151 (5755 Mhz)	NM ³				
Chain B/ Left side	12	802.11n40	151 (5755 Mhz)	NM ³				
Chain B/ Right side	12	802.11n40	151 (5755 Mhz)	NM ³				
Chain B/ Front side	12	802.11n40	159 (5795 Mhz)	NM ¹				

1 and 3: See remarks and comments

- 802.11ac80

Side / Position	Dist (mm)	Mode	Ch #. (Freq)	1-g SAR (W/Kg)	Power Drift (%)	Max Output Power (dBm)	Max. Reported 1-g SAR	Plot No.
Chain A/ Back side	12	802.11ac80	155 (5775 Mhz)	NM ³				
Chain A/ Front side	12	802.11ac80	155 (5775 Mhz)	0.483	-0.12	21	0.503	9
Chain A/ Top side	12	802.11ac80	155 (5775 Mhz)	NM ³				
Chain A/ Bottom side	12	802.11ac80	155 (5775 Mhz)	NM ³				
Chain A/ Left side	12	802.11ac80	155 (5775 Mhz)	NM ³				
Chain A/ Right side	12	802.11ac80	155 (5775 Mhz)	NM ³				

3: See remarks and comments

Side / Position	Dist (mm)	Mode	Ch #. (Freq)	1-g SAR (W/Kg)	Power Drift (%)	Max Output Power (dBm)	Max. Reported 1-g SAR	Plot No.
Chain B/ Back side	12	802.11ac80	155 (5775 Mhz)	NM ³				
Chain B/ Front side	12	802.11ac80	155 (5775 Mhz)	0.575	1.27	21	0.626	10
Chain B/ Top side	12	802.11ac80	155 (5775 Mhz)	NM ³				
Chain B/ Bottom side	12	802.11ac80	155 (5775 Mhz)	NM ³				
Chain B/ Left side	12	802.11ac80	155 (5775 Mhz)	NM ³				
Chain B/ Right side	12	802.11ac80	155 (5775 Mhz)	NM ³				

3: See remarks and comments

5.8. Enhanced Energy Coupling.

According to KDB 447981 D01 General Exposure Guidance v05r02, section 5.2.4, only modules with no host platform restrictions would need additional SAR evaluation due to RF energy coupling enhancements at increased test separation distance.

Appendix C – Measurement report

2.4 GHz – Chain A – d=12 mm – Back Side / 802.11b – CH 6 – Plot N°1

Test Laboratory: AT4 Wireless; Date: 20/05/2015

DUT: 8260D2W + SkyCross; Type: -; Serial: REF: H66846-003

Communication System: UID 10012 - CAA, IEEE 802.11b WiFi 2.4 GHz (DSSS, 1 Mbps); Frequency: 2412 MHz; Duty Cycle: 1:1.53815

Medium parameters used (interpolated): $f = 2412$ MHz; $\sigma = 1.96$ S/m; $\epsilon_r = 51.946$; $\rho = 1000$ kg/m³

Phantom section: Flat Section

DASY5 Configuration:

- Probe: ES3DV3 - SN3052; ConvF(4.3, 4.3, 4.3); Calibrated: 24/09/2014;
- Sensor-Surface: 3mm (Mechanical Surface Detection)
- Electronics: DAE4 Sn669; Calibrated: 08/07/2014
- Phantom: Flat Phantom ELI4.0; Type: QDOVA001BA; Serial: SN:1060
- Measurement SW: DASY52, Version 52.8 (8); SEMCAD X Version 14.6.10 (7331)

Modular SAR - 2.4GHz - Chain A, d= 12 mm/Back Side, Channel 6, 802.11b, 1Mbps/Area Scan (71x101x1):

Interpolated grid: dx=1.000 mm, dy=1.000 mm

[Info: Interpolated medium parameters used for SAR evaluation.](#)

Maximum value of SAR (interpolated) = 0.600 W/kg

Modular SAR - 2.4GHz - Chain A, d= 12 mm/Back Side, Channel 6, 802.11b, 1Mbps/Zoom Scan (7x7x7)/Cube 0:

Measurement grid: dx=5mm, dy=5mm, dz=5mm

Reference Value = 8.183 V/m; Power Drift = 0.17 dB

Peak SAR (extrapolated) = 0.886 W/kg

SAR(1 g) = 0.486 W/kg; SAR(10 g) = 0.267 W/kg (SAR corrected for target medium)

[Info: Interpolated medium parameters used for SAR evaluation.](#)

Maximum value of SAR (measured) = 0.593 W/kg

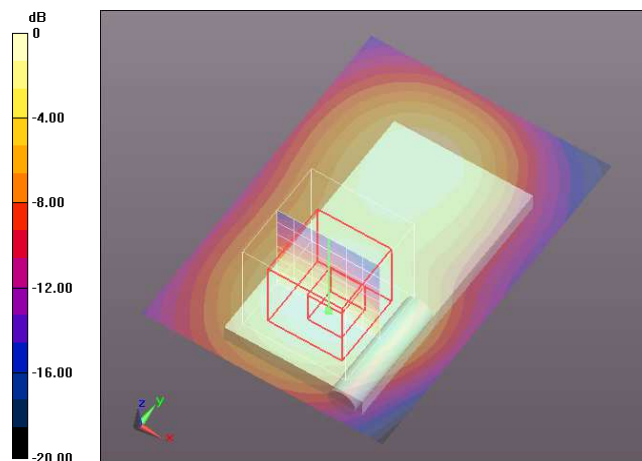

0 dB = 0.593 W/kg = -2.27 dBW/kg

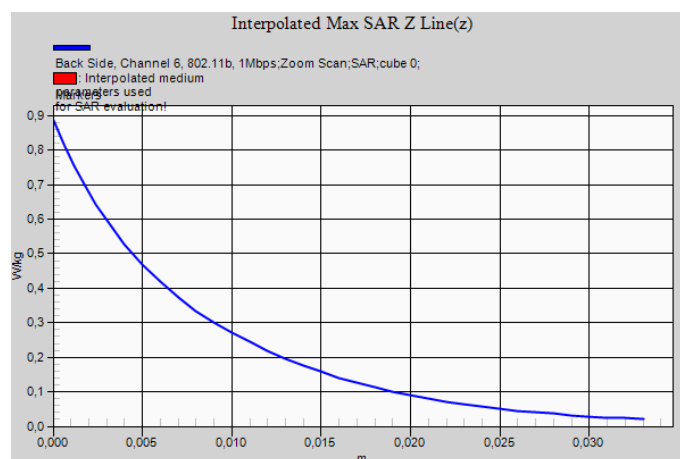

2.4 GHz – Chain B – d=12 mm – Back Side / 802.11b – CH 1 – Plot N°2

Test Laboratory: AT4 Wireless; Date: 21/05/2015

DUT: 8260D2W + SkyCross; Type: -; Serial: REF: H66846-003

Communication System: UID 10012 - CAA, IEEE 802.11b WiFi 2.4 GHz (DSSS, 1 Mbps); Frequency: 2412 MHz; Duty Cycle: 1:1.53815

Medium parameters used (interpolated): $f = 2412$ MHz; $\sigma = 1.96$ S/m; $\epsilon_r = 51.946$; $\rho = 1000$ kg/m³

Phantom section: Flat Section

DASY5 Configuration:

- Probe: ES3DV3 - SN3052; ConvF(4.3, 4.3, 4.3); Calibrated: 24/09/2014;
- Sensor-Surface: 3mm (Mechanical Surface Detection)
- Electronics: DAE4 Sn669; Calibrated: 08/07/2014
- Phantom: Flat Phantom ELI4.0; Type: QDOVA001BA; Serial: SN:1060
- Measurement SW: DASY52, Version 52.8 (8); SEMCAD X Version 14.6.10 (7331)

Modular SAR - 2.4GHz - Chain B, d= 12 mm/Back Side, Channel 1, 802.11b, 1Mbps/Area Scan (71x101x1):

Interpolated grid: dx=1.000 mm, dy=1.000 mm

[Info: Interpolated medium parameters used for SAR evaluation.](#)

Maximum value of SAR (interpolated) = 0.601 W/kg

Modular SAR - 2.4GHz - Chain B, d= 12 mm/Back Side, Channel 1, 802.11b, 1Mbps/Zoom Scan (7x7x7)/Cube 0:

Measurement grid: dx=5mm, dy=5mm, dz=5mm

Reference Value = 9.293 V/m; Power Drift = 0.03 dB

Peak SAR (extrapolated) = 0.870 W/kg

SAR(1 g) = 0.481 W/kg; SAR(10 g) = 0.267 W/kg (SAR corrected for target medium)

[Info: Interpolated medium parameters used for SAR evaluation.](#)

Maximum value of SAR (measured) = 0.588 W/kg

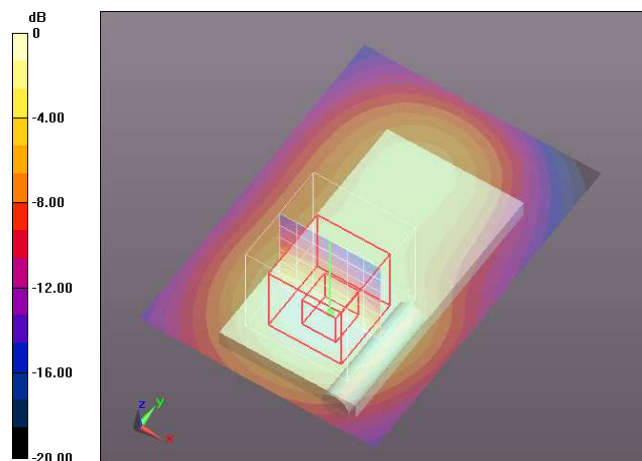

0 dB = 0.588 W/kg = -2.31 dBW/kg

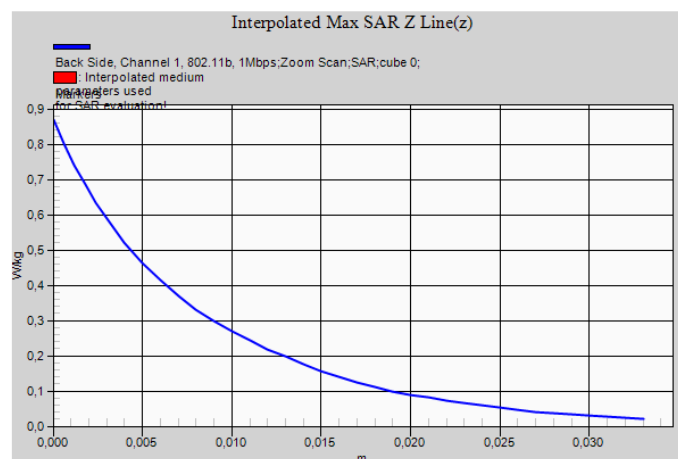

5.2 GHz – Chain A – d=12 mm – Front Side / 802.11a – CH 48 – Plot N°3

Test Laboratory: AT4 Wireless; Date: 22/05/2015

DUT: 8260D2W + SkyCross; Type: -; Serial: REF: H66846-003

Communication System: UID 10062 - CAA, IEEE 802.11a/h WiFi 5 GHz (OFDM, 6 Mbps); Frequency: 5240 MHz; Duty Cycle: 1:7.37904

Medium parameters used: $f = 5240$ MHz; $\sigma = 5.19$ S/m; $\epsilon_r = 50.04$; $\rho = 1000$ kg/m³

Phantom section: Flat Section

DASY5 Configuration:

- Probe: EX3DV4 - SN3687; ConvF(4.32, 4.32, 4.32); Calibrated: 14/07/2014;
- Sensor-Surface: 2mm (Mechanical Surface Detection (Locations From Previous Scan Used)), Sensor-Surface: 2mm (Mechanical Surface Detection)
- Electronics: DAE4 Sn669; Calibrated: 08/07/2014
- Phantom: Flat Phantom ELI4.0; Type: QDOVA001BA; Serial: SN:1060
- Measurement SW: DASY52, Version 52.8 (8); SEMCAD X Version 14.6.10 (7331)

Modular SAR - 5.2GHz - d=12mm/Chain A, Front Side, Channel 48, 802.11a, 6Mbps/Area Scan (61x91x1):

Interpolated grid: dx=1.000 mm, dy=1.000 mm

Maximum value of SAR (interpolated) = 1.10 W/kg

Modular SAR - 5.2GHz - d=12mm/Chain A, Front Side, Channel 48, 802.11a, 6Mbps/Zoom Scan (8x8x6)/Cube 0:

Measurement grid: dx=4mm, dy=4mm, dz=2mm

Reference Value = 9.649 V/m; Power Drift = 0.12 dB

Peak SAR (extrapolated) = 2.12 W/kg

SAR(1 g) = 0.580 W/kg; SAR(10 g) = 0.188 W/kg (SAR corrected for target medium)

Maximum value of SAR (measured) = 1.08 W/kg

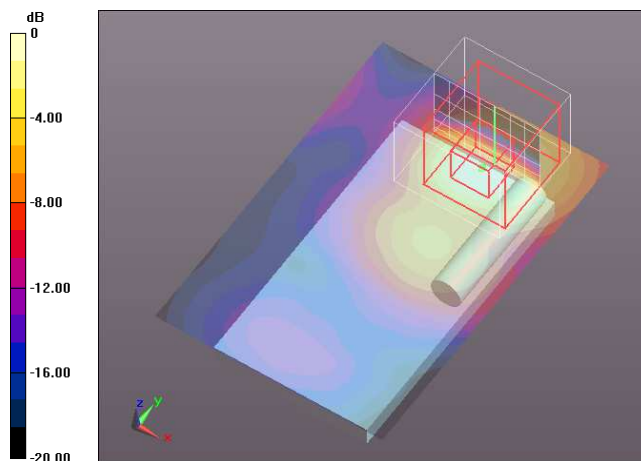

0 dB = 1.08 W/kg = 0.33 dBW/kg

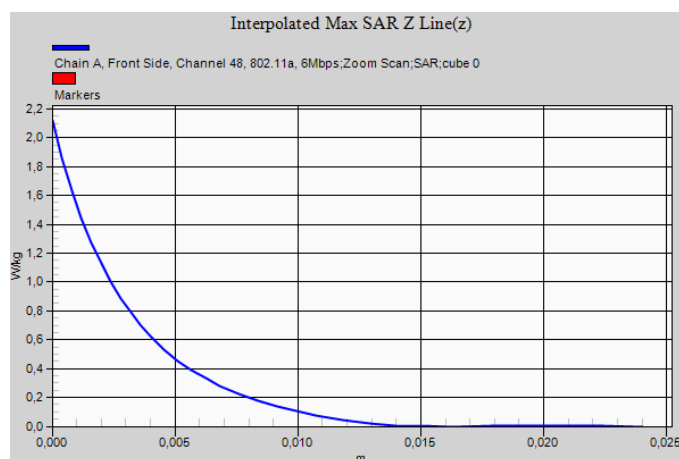

5.2 GHz – Chain B – d=12 mm – Front Side / 802.11a – CH 48 – Plot N°4

Test Laboratory: AT4 Wireless; Date: 22/05/2015

DUT: 8260D2W + SkyCross; Type: -; Serial: REF: H66846-003

Communication System: UID 10062 - CAA, IEEE 802.11a/h WiFi 5 GHz (OFDM, 6 Mbps); Frequency: 5240 MHz; Duty Cycle: 1:7.37904

Medium parameters used: $f = 5240$ MHz; $\sigma = 5.19$ S/m; $\epsilon_r = 50.04$; $\rho = 1000$ kg/m³

Phantom section: Flat Section

DASY5 Configuration:

- Probe: EX3DV4 - SN3687; ConvF(4.32, 4.32, 4.32); Calibrated: 14/07/2014;
- Sensor-Surface: 2mm (Mechanical Surface Detection (Locations From Previous Scan Used)), Sensor-Surface: 2mm (Mechanical Surface Detection)
- Electronics: DAE4 Sn669; Calibrated: 08/07/2014
- Phantom: Flat Phantom ELI4.0; Type: QDOVA001BA; Serial: SN:1060
- Measurement SW: DASY52, Version 52.8 (8); SEMCAD X Version 14.6.10 (7331)

Modular SAR - 5.2GHz - d=12mm/Chain B, Front Side, Channel 48, 802.11a, 6Mbps/Area Scan (61x91x1): Interpolated grid: dx=1.000 mm, dy=1.000 mm
Maximum value of SAR (interpolated) = 1.14 W/kg

Modular SAR - 5.2GHz - d=12mm/Chain B, Front Side, Channel 48, 802.11a, 6Mbps/Zoom Scan (8x8x6)/Cube 0:

Measurement grid: dx=4mm, dy=4mm, dz=2mm

Reference Value = 10.20 V/m; Power Drift = 0.08 dB

Peak SAR (extrapolated) = 2.22 W/kg

SAR(1 g) = 0.609 W/kg; SAR(10 g) = 0.197 W/kg (SAR corrected for target medium)

Maximum value of SAR (measured) = 1.13 W/kg

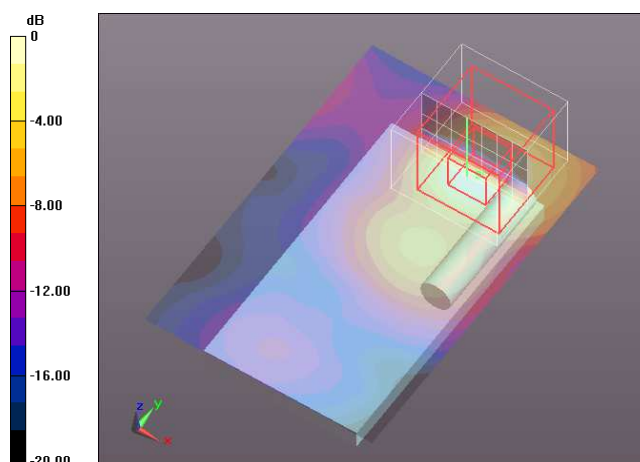

0 dB = 1.13 W/kg = 0.53 dBW/kg

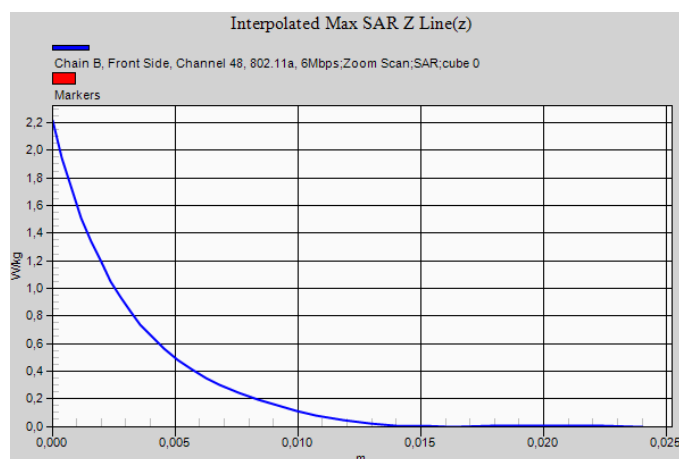

5.3 GHz – Chain A – d=12 mm – Top Side / 802.11a – CH 52 – Plot N°5

Test Laboratory: AT4 Wireless; Date: 25/05/2015

DUT: 8260D2W + SkyCross; Type: -; Serial: REF: H66846-003

Communication System: UID 10062 - CAA, IEEE 802.11a/h WiFi 5 GHz (OFDM, 6 Mbps); Frequency: 5260 MHz; Duty Cycle: 1:7.37904

Medium parameters used: $f = 5260$ MHz; $\sigma = 5.27$ S/m; $\epsilon_r = 50.18$; $\rho = 1000$ kg/m³

Phantom section: Flat Section

DASY5 Configuration:

- Probe: EX3DV4 - SN3687; ConvF(4.15, 4.15, 4.15); Calibrated: 14/07/2014;
- Sensor-Surface: 2mm (Mechanical Surface Detection)
- Electronics: DAE4 Sn669; Calibrated: 08/07/2014
- Phantom: Flat Phantom ELI4.0; Type: QDOVA001BA; Serial: SN:1060
- Measurement SW: DASY52, Version 52.8 (8); SEMCAD X Version 14.6.10 (7331)

Modular SAR - 5.3GHz - d=12mm/Chain A, Top Side, Channel 52, 802.11a, 6Mbps/Area Scan (51x91x1):

Interpolated grid: dx=1.000 mm, dy=1.000 mm

Maximum value of SAR (interpolated) = 1.24 W/kg

Modular SAR - 5.3GHz - d=12mm/Chain A, Top Side, Channel 52, 802.11a, 6Mbps/Zoom Scan (8x8x6)/Cube 0:

Measurement grid: dx=4mm, dy=4mm, dz=2mm

Reference Value = 12.65 V/m; Power Drift = 0.11 dB

Peak SAR (extrapolated) = 2.38 W/kg

SAR(1 g) = 0.693 W/kg; SAR(10 g) = 0.242 W/kg (SAR corrected for target medium)

Maximum value of SAR (measured) = 1.31 W/kg

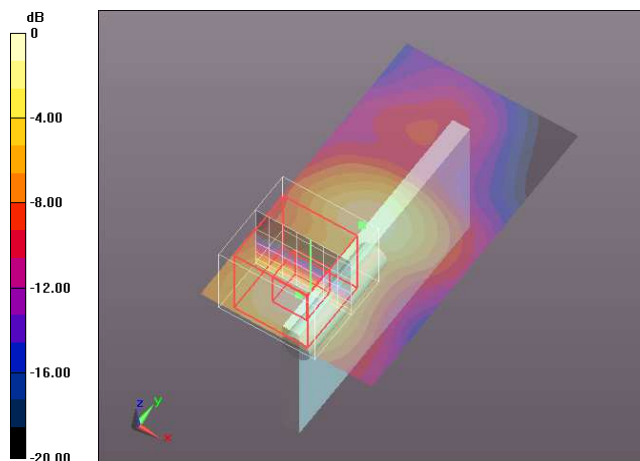

0 dB = 1.31 W/kg = 1.17 dBW/kg

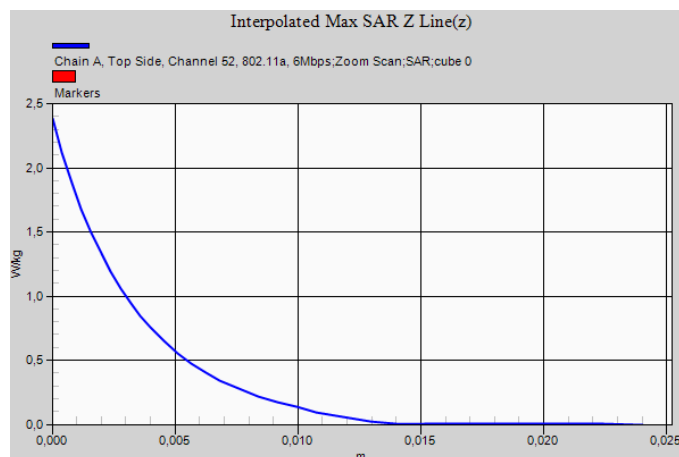

5.3 GHz – Chain B – d=12 mm – Front Side / 802.11n40 – CH 54 – Plot N°6

Test Laboratory: AT4 Wireless; Date: 25/05/2015

DUT: 8260D2W + SkyCross; Type: -; Serial: REF: H66846-003

Communication System: UID 10117 - CAA, IEEE 802.11n (HT Mixed, 13.5 Mbps, BPSK); Frequency: 5270 MHz; Duty Cycle: 1:6.4121

Medium parameters used (interpolated): $f = 5270$ MHz; $\sigma = 5.29$ S/m; $\epsilon_r = 50.175$; $\rho = 1000$ kg/m³

Phantom section: Flat Section

DASY5 Configuration:

- Probe: EX3DV4 - SN3687; ConvF(4.15, 4.15, 4.15); Calibrated: 14/07/2014;
- Sensor-Surface: 2mm (Mechanical Surface Detection (Locations From Previous Scan Used)), Sensor-Surface: 2mm (Mechanical Surface Detection)
- Electronics: DAE4 Sn669; Calibrated: 08/07/2014
- Phantom: Flat Phantom ELI4.0; Type: QDOVA001BA; Serial: SN:1060
- Measurement SW: DASY52, Version 52.8 (8); SEMCAD X Version 14.6.10 (7331)

Modular SAR - 5.3GHz - d=12mm/Chain B, Front Side, Channel 54, 802.11n40, HT0/Area Scan (61x91x1):

Interpolated grid: dx=1.000 mm, dy=1.000 mm

[Info: Interpolated medium parameters used for SAR evaluation.](#)

Maximum value of SAR (interpolated) = 1.24 W/kg

Modular SAR - 5.3GHz - d=12mm/Chain B, Front Side, Channel 54, 802.11n40, HT0/Zoom Scan (8x8x6)/Cube 0:

Measurement grid: dx=4mm, dy=4mm, dz=2mm

Reference Value = 10.38 V/m; Power Drift = 0.09 dB

Peak SAR (extrapolated) = 2.27 W/kg

SAR(1 g) = 0.632 W/kg; SAR(10 g) = 0.209 W/kg (SAR corrected for target medium)

[Info: Interpolated medium parameters used for SAR evaluation.](#)

Maximum value of SAR (measured) = 1.18 W/kg

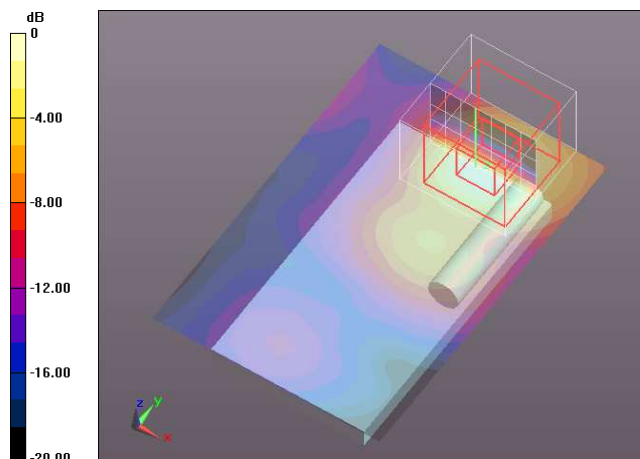

0 dB = 1.18 W/kg = 0.72 dBW/kg

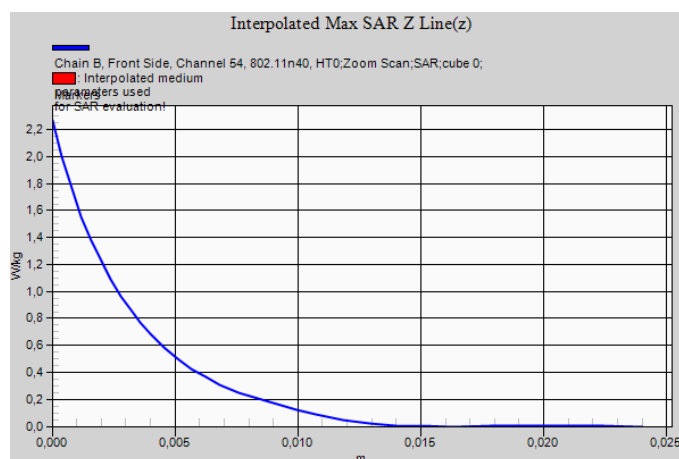

5.6 GHz – Chain A – d=12 mm – Front Side / 802.11a – CH 116 – Plot N°7

Test Laboratory: AT4 Wireless; Date: 26/05/2015

DUT: 8260D2W + SkyCross; Type: -; Serial: REF: H66846-003

Communication System: UID 10062 - CAA, IEEE 802.11a/h WiFi 5 GHz (OFDM, 6 Mbps); Frequency: 5580 MHz; Duty Cycle: 1:7.37904

Medium parameters used: $f = 5580$ MHz; $\sigma = 5.73$ S/m; $\epsilon_r = 48.11$; $\rho = 1000$ kg/m³

Phantom section: Flat Section

DASY5 Configuration:

- Probe: EX3DV4 - SN3687; ConvF(3.67, 3.67, 3.67); Calibrated: 14/07/2014;
- Sensor-Surface: 2mm (Mechanical Surface Detection)
- Electronics: DAE4 Sn669; Calibrated: 08/07/2014
- Phantom: Flat Phantom ELI4.0; Type: QDOVA001BA; Serial: SN:1060
- Measurement SW: DASY52, Version 52.8 (8); SEMCAD X Version 14.6.10 (7331)

Modular SAR - 5.5GHz - d=12mm/Chain A, Front Side, Channel 116, 802.11a, 6Mbps/Area Scan (61x91x1):

Interpolated grid: dx=1.000 mm, dy=1.000 mm

Maximum value of SAR (interpolated) = 1.10 W/kg

Modular SAR - 5.5GHz - d=12mm/Chain A, Front Side, Channel 116, 802.11a, 6Mbps/Zoom Scan (8x8x6)/Cube 0:

Measurement grid: dx=4mm, dy=4mm, dz=2mm

Reference Value = 10.86 V/m; Power Drift = 0.14 dB

Peak SAR (extrapolated) = 2.16 W/kg

SAR(1 g) = 0.552 W/kg; SAR(10 g) = 0.171 W/kg (SAR corrected for target medium)

Maximum value of SAR (measured) = 1.11 W/kg

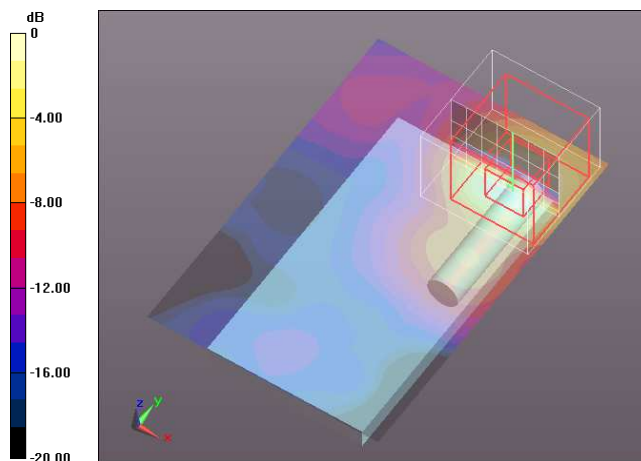

0 dB = 1.11 W/kg = 0.45 dBW/kg

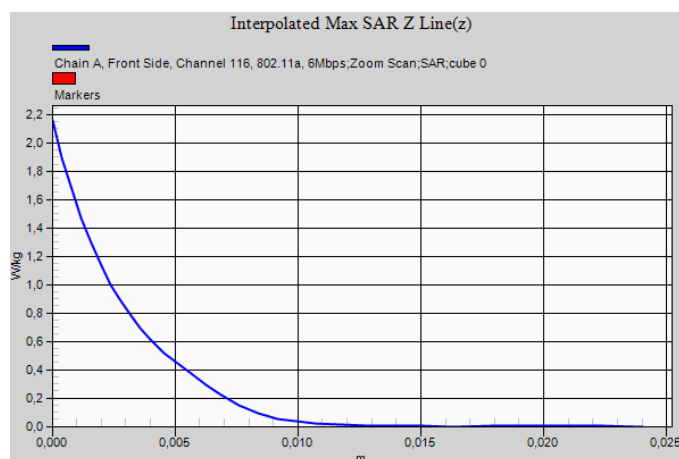

5.6 GHz – Chain B – d=12 mm – Front Side / 802.11a – CH 116 – Plot N°8

Test Laboratory: AT4 Wireless; Date: 26/05/2015

DUT: 8260D2W + SkyCross; Type: -; Serial: REF: H66846-003

Communication System: UID 10062 - CAA, IEEE 802.11a/h WiFi 5 GHz (OFDM, 6 Mbps); Frequency: 5580 MHz; Duty Cycle: 1:7.37904

Medium parameters used: $f = 5580$ MHz; $\sigma = 5.73$ S/m; $\epsilon_r = 48.11$; $\rho = 1000$ kg/m³

Phantom section: Flat Section

DASY5 Configuration:

- Probe: EX3DV4 - SN3687; ConvF(3.67, 3.67, 3.67); Calibrated: 14/07/2014;
- Sensor-Surface: 2mm (Mechanical Surface Detection (Locations From Previous Scan Used)), Sensor-Surface: 2mm (Mechanical Surface Detection)
- Electronics: DAE4 Sn669; Calibrated: 08/07/2014
- Phantom: Flat Phantom ELI4.0; Type: QDOVA001BA; Serial: SN:1060
- Measurement SW: DASY52, Version 52.8 (8); SEMCAD X Version 14.6.10 (7331)

Modular SAR - 5.5GHz - d=12mm/Chain B, Front Side, Channel 116, 802.11a, 6Mbps/Area Scan (61x91x1):

Interpolated grid: dx=1.000 mm, dy=1.000 mm

Maximum value of SAR (interpolated) = 1.26 W/kg

Modular SAR - 5.5GHz - d=12mm/Chain B, Front Side, Channel 116, 802.11a, 6Mbps/Zoom Scan (8x8x6)/Cube 0:

Measurement grid: dx=4mm, dy=4mm, dz=2mm

Reference Value = 11.74 V/m; Power Drift = -0.03 dB

Peak SAR (extrapolated) = 2.53 W/kg

SAR(1 g) = 0.642 W/kg; SAR(10 g) = 0.200 W/kg (SAR corrected for target medium)

Maximum value of SAR (measured) = 1.24 W/kg

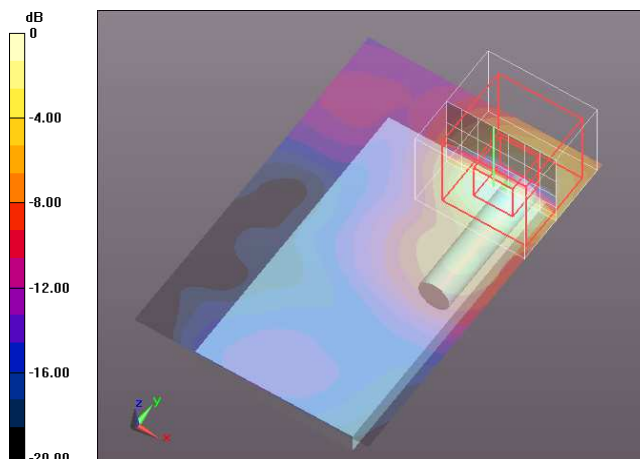

0 dB = 1.24 W/kg = 0.93 dBW/kg

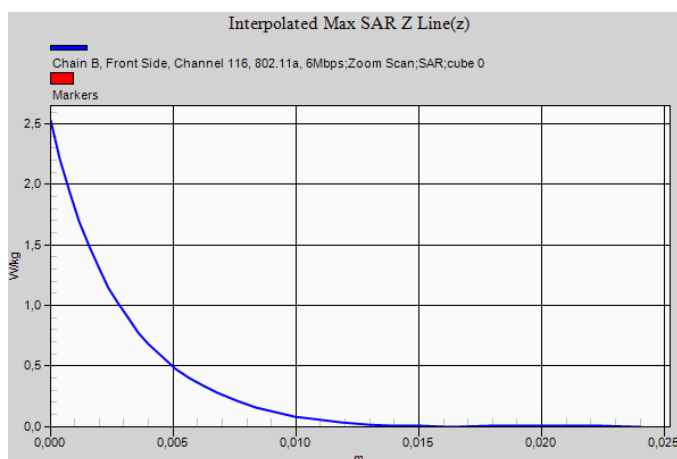

5.8 GHz – Chain A – d=12 mm – Front Side / 802.11ac80 – CH 155 – Plot N°9

Test Laboratory: AT4 Wireless; Date: 27/05/2015

DUT: 8260D2W + SkyCross; Type: -; Serial: REF: H66846-003

Communication System: UID 10402 - AAA, IEEE 802.11ac WiFi (80MHz, 64-QAM, 99pc duty cycle); Frequency: 5775 MHz; Duty Cycle: 1:7.12853

Medium parameters used (interpolated): $f = 5775$ MHz; $\sigma = 6.21$ S/m; $\epsilon_r = 47.565$; $\rho = 1000$ kg/m³

Phantom section: Flat Section

DASY5 Configuration:

- Probe: EX3DV4 - SN3687; ConvF(3.89, 3.89, 3.89); Calibrated: 14/07/2014;
- Sensor-Surface: 2mm (Mechanical Surface Detection (Locations From Previous Scan Used)), Sensor-Surface: 2mm (Mechanical Surface Detection)
- Electronics: DAE4 Sn669; Calibrated: 08/07/2014
- Phantom: Flat Phantom ELI4.0; Type: QDOVA001BA; Serial: SN:1060
- Measurement SW: DASY52, Version 52.8 (8); SEMCAD X Version 14.6.10 (7331)

Modular SAR - 5.8GHz - d=12mm/Chain A, Front Side, Channel 155, 802.11ac80, VHT0/Area Scan (61x91x1):

Interpolated grid: dx=1.000 mm, dy=1.000 mm

[Info: Interpolated medium parameters used for SAR evaluation.](#)

Maximum value of SAR (interpolated) = 0.988 W/kg

Modular SAR - 5.8GHz - d=12mm/Chain A, Front Side, Channel 155, 802.11ac80, VHT0/Zoom Scan (8x8x6)/Cube 0:

Measurement grid: dx=4mm, dy=4mm, dz=2mm

Reference Value = 7.240 V/m; Power Drift = -0.01 dB

Peak SAR (extrapolated) = 2.01 W/kg

SAR(1 g) = 0.483 W/kg; SAR(10 g) = 0.154 W/kg (SAR corrected for target medium)

[Info: Interpolated medium parameters used for SAR evaluation.](#)

Maximum value of SAR (measured) = 0.985 W/kg

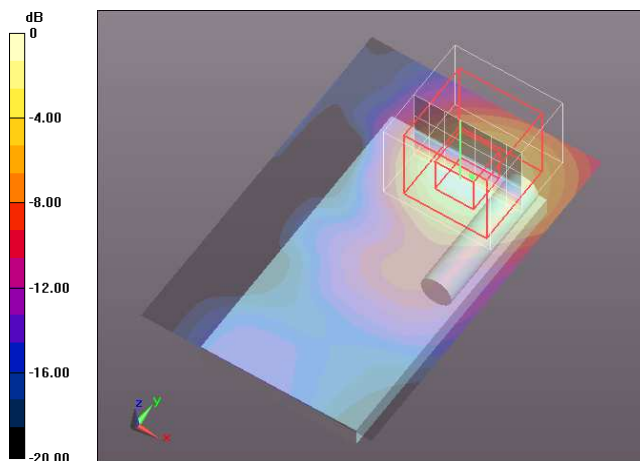

0 dB = 0.985 W/kg = -0.07 dBW/kg

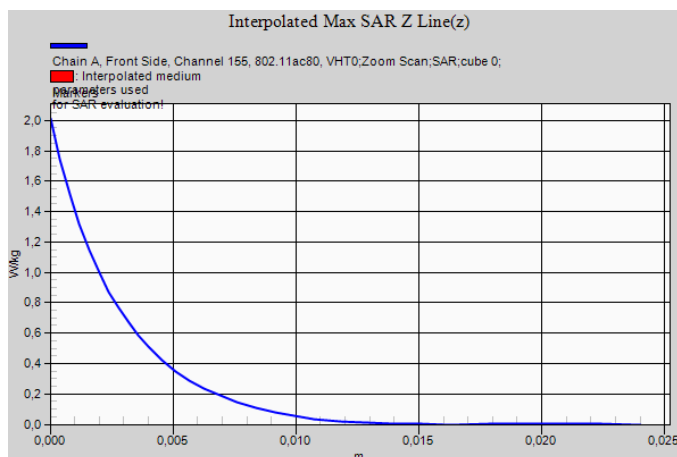

5.8 GHz – Chain B – d=12 mm – Front Side / 802.11ac80 – CH 155 – Plot N°10

Test Laboratory: AT4 Wireless; Date: 27/05/2015

DUT: 8260D2W + SkyCross; Type: -; Serial: REF: H66846-003

Communication System: UID 10402 - AAA, IEEE 802.11ac WiFi (80MHz, 64-QAM, 99pc duty cycle); Frequency: 5775 MHz; Duty Cycle: 1:7.12853

Medium parameters used (interpolated): $f = 5775$ MHz; $\sigma = 6.21$ S/m; $\epsilon_r = 47.565$; $\rho = 1000$ kg/m³

Phantom section: Flat Section

DASY5 Configuration:

- Probe: EX3DV4 - SN3687; ConvF(3.89, 3.89, 3.89); Calibrated: 14/07/2014;
- Sensor-Surface: 2mm (Mechanical Surface Detection (Locations From Previous Scan Used)), Sensor-Surface: 2mm (Mechanical Surface Detection)
- Electronics: DAE4 Sn669; Calibrated: 08/07/2014
- Phantom: Flat Phantom ELI4.0; Type: QDOVA001BA; Serial: SN:1060
- Measurement SW: DASY52, Version 52.8 (8); SEMCAD X Version 14.6.10 (7331)

Modular SAR - 5.8GHz - d=12mm/Chain B, Front Side, Channel 155, 802.11ac80, VHT0/Area Scan (61x91x1):

Interpolated grid: dx=1.000 mm, dy=1.000 mm

[Info: Interpolated medium parameters used for SAR evaluation.](#)

Maximum value of SAR (interpolated) = 1.19 W/kg

Modular SAR - 5.8GHz - d=12mm/Chain B, Front Side, Channel 155, 802.11ac80, VHT0/Zoom Scan (8x8x6)/Cube 0:

Measurement grid: dx=4mm, dy=4mm, dz=2mm

Reference Value = 7.782 V/m; Power Drift = 0.11 dB

Peak SAR (extrapolated) = 2.34 W/kg

SAR(1 g) = 0.575 W/kg; SAR(10 g) = 0.180 W/kg (SAR corrected for target medium)

[Info: Interpolated medium parameters used for SAR evaluation.](#)

Maximum value of SAR (measured) = 1.12 W/kg

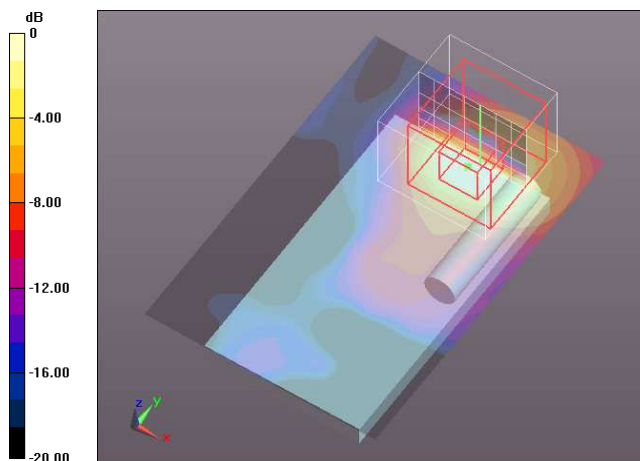

0 dB = 1.12 W/kg = 0.49 dBW/kg

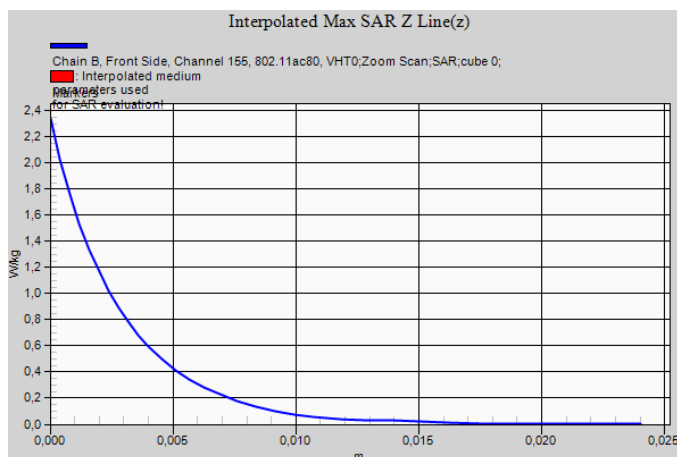

Appendix D – System Validation Reports

Validation results in 2450 MHz Band for Body TSL

Test Laboratory: AT4 Wireless; Date: 20/05/2015

DUT: Dipole 2450 MHz D2450V2; Type: D2450V2; Serial: D2450V2 - SN:756

Communication System: UID 10000, CW; Frequency: 2450 MHz; Duty Cycle: 1:1

Medium parameters used: $f = 2450$ MHz; $\sigma = 1.98$ S/m; $\epsilon_r = 51.61$; $\rho = 1000$ kg/m³

Phantom section: Flat Section

DASY5 Configuration:

- Probe: ES3DV3 - SN3052; ConvF(4.3, 4.3, 4.3); Calibrated: 24/09/2014;
- Sensor-Surface: 3mm (Mechanical Surface Detection)
- Electronics: DAE4 Sn669; Calibrated: 08/07/2014
- Phantom: Flat Phantom ELI4.0; Type: QDOVA001BA; Serial: SN:1060
- Measurement SW: DASY52, Version 52.8 (8); SEMCAD X Version 14.6.10 (7331)

System Performance Check with D2450V2 Dipole/d=10mm, Pin=250mW/Area Scan (61x61x1):

Interpolated grid: dx=1.500 mm, dy=1.500 mm

Maximum value of SAR (interpolated) = 16.8 W/kg

System Performance Check with D2450V2 Dipole/d=10mm, Pin=250mW/Zoom Scan (7x7x7)/Cube 0:

Measurement grid: dx=5mm, dy=5mm, dz=5mm

Reference Value = 94.69 V/m; Power Drift = -0.23 dB

Peak SAR (extrapolated) = 25.6 W/kg

SAR(1 g) = 12.2 W/kg; SAR(10 g) = 5.7 W/kg (SAR corrected for target medium)

Maximum value of SAR (measured) = 16.2 W/kg

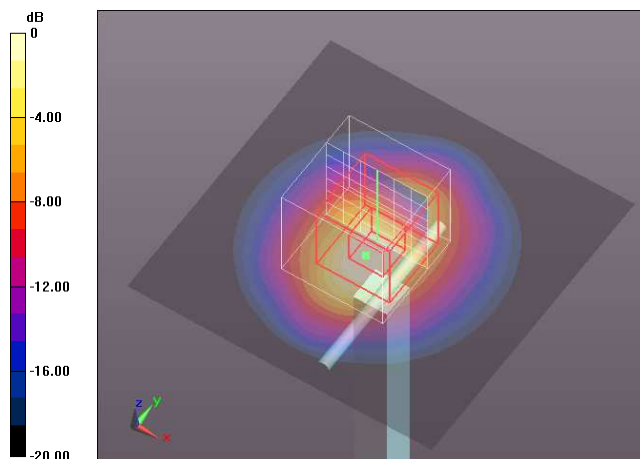

0 dB = 16.2 W/kg = 12.10 dBW/kg

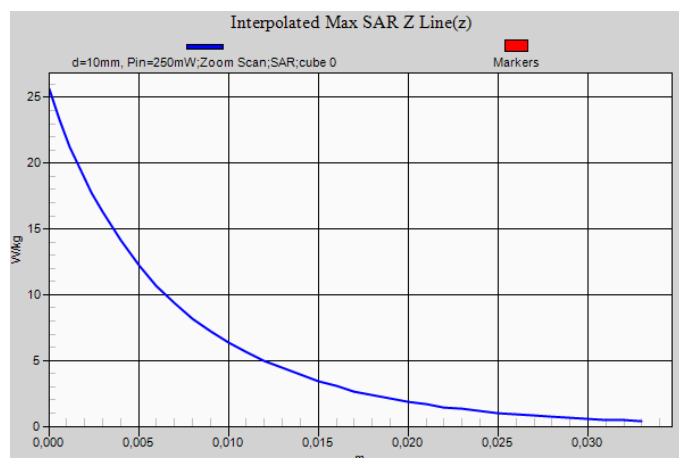

Validation results in 2450 MHz Band for Body TSL

Test Laboratory: AT4 Wireless; Date: 28/05/2015

DUT: Dipole 2450 MHz D2450V2; Type: D2450V2; Serial: D2450V2 - SN:756

Communication System: UID 10000, CW; Frequency: 2450 MHz; Duty Cycle: 1:1

Medium parameters used: $f = 2450$ MHz; $\sigma = 1.95$ S/m; $\epsilon_r = 51.55$; $\rho = 1000$ kg/m³

Phantom section: Flat Section

DASY5 Configuration:

- Probe: ES3DV3 - SN3052; ConvF(4.3, 4.3, 4.3); Calibrated: 24/09/2014;
- Sensor-Surface: 3mm (Mechanical Surface Detection)
- Electronics: DAE4 Sn669; Calibrated: 08/07/2014
- Phantom: Flat Phantom ELI4.0; Type: QDOVA001BA; Serial: SN:1060
- Measurement SW: DASY52, Version 52.8 (8); SEMCAD X Version 14.6.10 (7331)

System Performance Check with D2450V2 Dipole, 28-05-2015/d=10mm, Pin=250mW/Area Scan (61x61x1):

Interpolated grid: dx=1.500 mm, dy=1.500 mm

Maximum value of SAR (interpolated) = 16.9 W/kg

System Performance Check with D2450V2 Dipole, 28-05-2015/d=10mm, Pin=250mW/Zoom Scan (7x7x7)/Cube 0:

Measurement grid: dx=5mm, dy=5mm, dz=5mm

Reference Value = 87.60 V/m; Power Drift = 0.04 dB

Peak SAR (extrapolated) = 25.2 W/kg

SAR(1 g) = 12.1 W/kg; SAR(10 g) = 5.62 W/kg (SAR corrected for target medium)

Maximum value of SAR (measured) = 15.9 W/kg

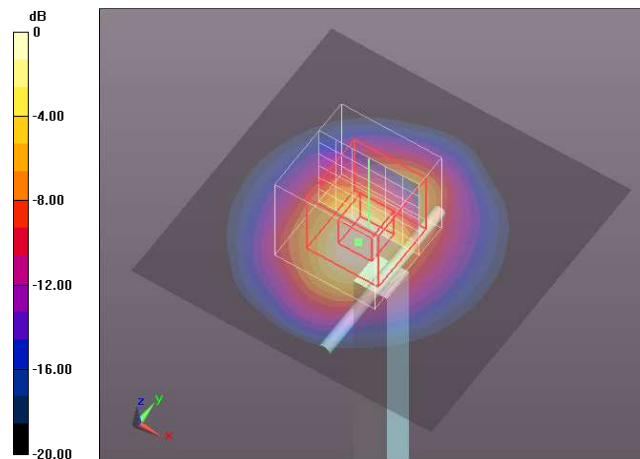

0 dB = 15.9 W/kg = 12.01 dBW/kg

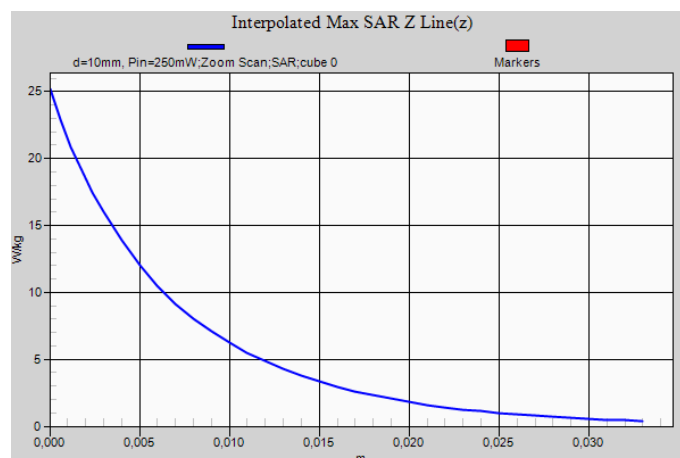

Validation results in 5200 MHz Band for Body TSL

Test Laboratory: AT4 Wireless; Date: 21/05/2015

DUT: Dipole D5GHzV2; Type: D5GHzV2; Serial: D5GHzV2 - SN:1071

Communication System: UID 0, CW-5GHz; Frequency: 5200 MHz; Duty Cycle: 1:1

Medium parameters used: $f = 5200$ MHz; $\sigma = 5.17$ S/m; $\epsilon_r = 50.19$; $\rho = 1000$ kg/m³

Phantom section: Flat Section

DASY5 Configuration:

- Probe: EX3DV4 - SN3687; ConvF(4.32, 4.32, 4.32); Calibrated: 14/07/2014;
- Sensor-Surface: 2mm (Mechanical Surface Detection)
- Electronics: DAE4 Sn669; Calibrated: 08/07/2014
- Phantom: Flat Phantom ELI4.0; Type: QDOVA001BA; Serial: SN:1060
- Measurement SW: DASY52, Version 52.8 (8); SEMCAD X Version 14.6.10 (7331)

System Performance Check with D5.2GHzV2 Dipole/d=10mm, Pin=100mW, f=5200 MHz/Area Scan (61x61x1):

Interpolated grid: dx=1.000 mm, dy=1.000 mm

Maximum value of SAR (interpolated) = 14.5 W/kg

System Performance Check with D5.2GHzV2 Dipole/d=10mm, Pin=100mW, f=5200 MHz/Zoom Scan (4x4x2mm), dist=2mm (8x8x13)/Cube 0:

Measurement grid: dx=4mm, dy=4mm, dz=2mm

Reference Value = 55.03 V/m; Power Drift = 0.20 dB

Peak SAR (extrapolated) = 27.3 W/kg

SAR(1 g) = 7.11 W/kg; SAR(10 g) = 2.03 W/kg (SAR corrected for target medium)

Maximum value of SAR (measured) = 13.7 W/kg

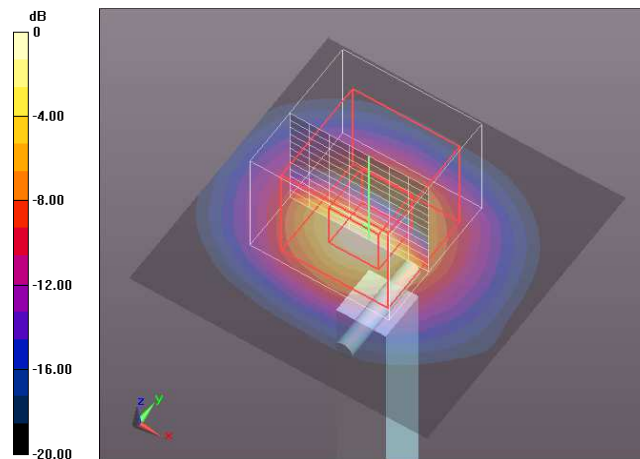

0 dB = 13.7 W/kg = 11.37 dBW/kg

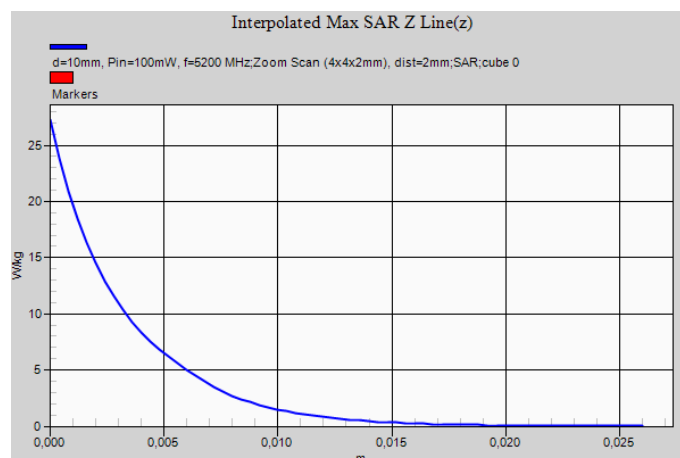

Validation results in 5200 MHz Band for Body TSL

Test Laboratory: AT4 Wireless; Date: 25/05/2015

DUT: Dipole D5GHzV2; Type: D5GHzV2; Serial: D5GHzV2 - SN:1071

Communication System: UID 0, CW-5GHz; Frequency: 5200 MHz; Duty Cycle: 1:1

Medium parameters used: $f = 5200$ MHz; $\sigma = 5.2$ S/m; $\epsilon_r = 50.37$; $\rho = 1000$ kg/m³

Phantom section: Flat Section

DASY5 Configuration:

- Probe: EX3DV4 - SN3687; ConvF(4.32, 4.32, 4.32); Calibrated: 14/07/2014;
- Sensor-Surface: 2mm (Mechanical Surface Detection)
- Electronics: DAE4 Sn669; Calibrated: 08/07/2014
- Phantom: Flat Phantom ELI4.0; Type: QDOVA001BA; Serial: SN:1060
- Measurement SW: DASY52, Version 52.8 (8); SEMCAD X Version 14.6.10 (7331)

System Performance Check with D5.2GHzV2 Dipole 25_05_2015/d=10mm, Pin=100mW, f=5200 MHz/Area Scan (61x61x1):

Interpolated grid: dx=1.000 mm, dy=1.000 mm

Maximum value of SAR (interpolated) = 14.9 W/kg

System Performance Check with D5.2GHzV2 Dipole 25_05_2015/d=10mm, Pin=100mW, f=5200 MHz/Zoom Scan (4x4x2mm), dist=2mm (8x8x13)/Cube 0:

Measurement grid: dx=4mm, dy=4mm, dz=2mm

Reference Value = 56.39 V/m; Power Drift = 0.05 dB

Peak SAR (extrapolated) = 28.1 W/kg

SAR(1 g) = 7.24 W/kg; SAR(10 g) = 2.06 W/kg (SAR corrected for target medium)

Maximum value of SAR (measured) = 13.5 W/kg

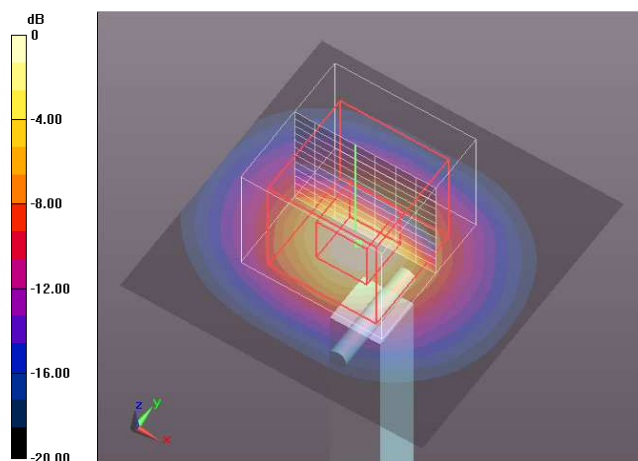

0 dB = 13.5 W/kg = 11.30 dBW/kg

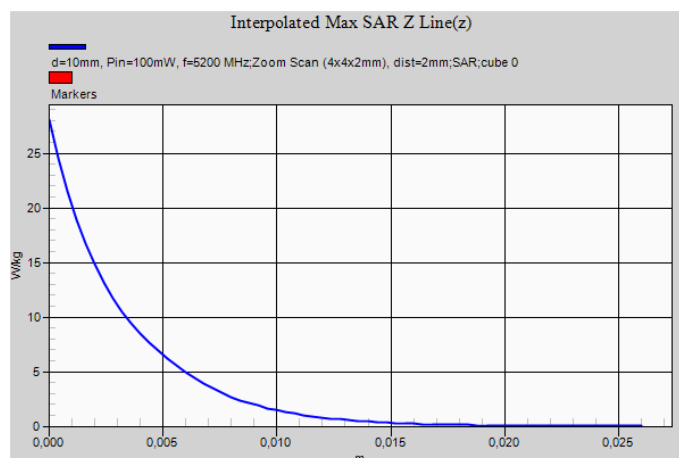

Validation results in 5500 MHz Band for Body TSL

Test Laboratory: AT4 Wireless; Date: 26/05/2015

DUT: Dipole D5GHzV2; Type: D5GHzV2; Serial: D5GHzV2 - SN:1071

Communication System: UID 0, CW-5GHz; Frequency: 5500 MHz; Duty Cycle: 1:1

Medium parameters used: $f = 5500$ MHz; $\sigma = 5.61$ S/m; $\epsilon_r = 48.35$; $\rho = 1000$ kg/m³

Phantom section: Flat Section

DASY5 Configuration:

- Probe: EX3DV4 - SN3687; ConvF(3.67, 3.67, 3.67); Calibrated: 14/07/2014;
- Sensor-Surface: 2mm (Mechanical Surface Detection)
- Electronics: DAE4 Sn669; Calibrated: 08/07/2014
- Phantom: Flat Phantom ELI4.0; Type: QDOVA001BA; Serial: SN:1060
- Measurement SW: DASY52, Version 52.8 (8); SEMCAD X Version 14.6.10 (7331)

System Performance Check with D5.5GHzV2 Dipole/d=10mm, Pin=100mW, f=5500 MHz/Area Scan (61x61x1):

Interpolated grid: dx=1.000 mm, dy=1.000 mm

Maximum value of SAR (interpolated) = 15.7 W/kg

System Performance Check with D5.5GHzV2 Dipole/d=10mm, Pin=100mW, f=5500 MHz/Zoom Scan (4x4x2mm), dist=2mm (8x8x13)/Cube 0:

Measurement grid: dx=4mm, dy=4mm, dz=2mm

Reference Value = 53.61 V/m; Power Drift = 0.39 dB

Peak SAR (extrapolated) = 31.4 W/kg

SAR(1 g) = 7.68 W/kg; SAR(10 g) = 2.14 W/kg (SAR corrected for target medium)

Maximum value of SAR (measured) = 15.4 W/kg

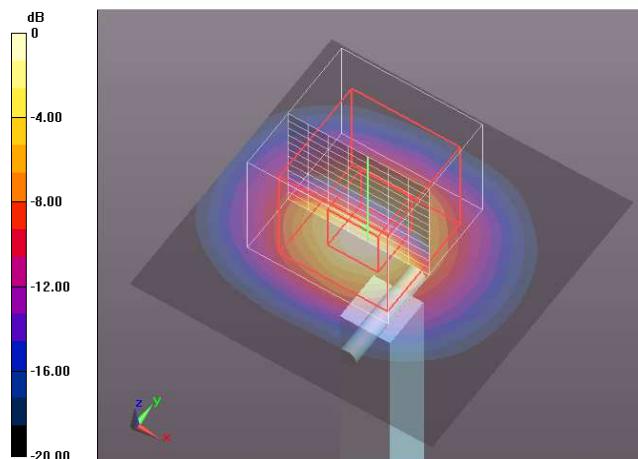

0 dB = 15.4 W/kg = 11.88 dBW/kg

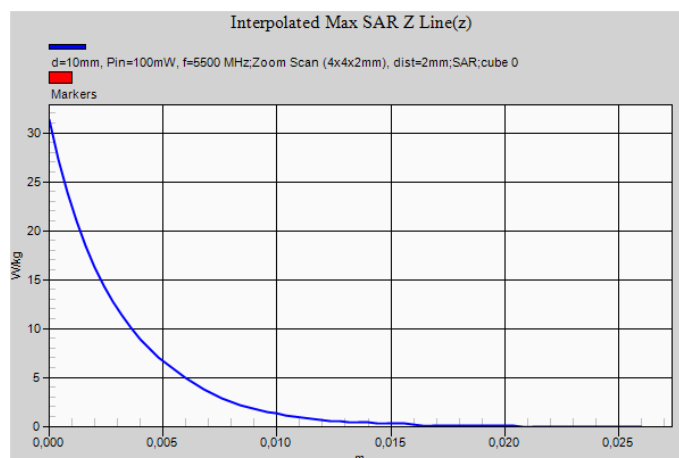

Validation results in 5800 MHz Band for Body TSL

Test Laboratory: AT4 Wireless; Date: 27/05/2015

DUT: Dipole D5GHzV2; Type: D5GHzV2; Serial: D5GHzV2 - SN:1071

Communication System: UID 0, CW-5GHz; Frequency: 5800 MHz; Duty Cycle: 1:1

Medium parameters used: $f = 5800$ MHz; $\sigma = 6.2$ S/m; $\epsilon_r = 47.6$; $\rho = 1000$ kg/m³

Phantom section: Flat Section

DASY5 Configuration:

- Probe: EX3DV4 - SN3687; ConvF(3.89, 3.89, 3.89); Calibrated: 14/07/2014;
- Sensor-Surface: 2mm (Mechanical Surface Detection)
- Electronics: DAE4 Sn669; Calibrated: 08/07/2014
- Phantom: Flat Phantom ELI4.0; Type: QDOVA001BA; Serial: SN:1060
- Measurement SW: DASY52, Version 52.8 (8); SEMCAD X Version 14.6.10 (7331)

System Performance Check with D5.8GHzV2 Dipole/d=10mm, Pin=100mW, f=5800 MHz/Area Scan (61x61x1):

Interpolated grid: dx=1.000 mm, dy=1.000 mm

Maximum value of SAR (interpolated) = 15.7 W/kg

System Performance Check with D5.8GHzV2 Dipole/d=10mm, Pin=100mW, f=5800 MHz/Zoom Scan (4x4x2mm), dist=2mm (8x8x13)/Cube 0:

Measurement grid: dx=4mm, dy=4mm, dz=2mm

Reference Value = 52.06 V/m; Power Drift = 0.12 dB

Peak SAR (extrapolated) = 33.8 W/kg

SAR(1 g) = 7.72 W/kg; SAR(10 g) = 2.14 W/kg (SAR corrected for target medium)

Maximum value of SAR (measured) = 15.3 W/kg

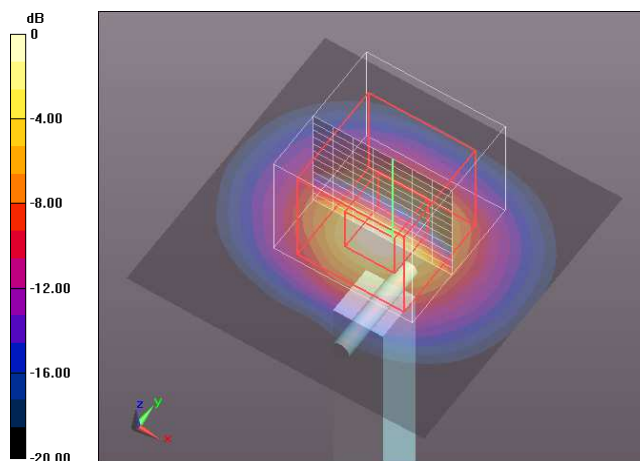

0 dB = 15.3 W/kg = 11.85 dBW/kg

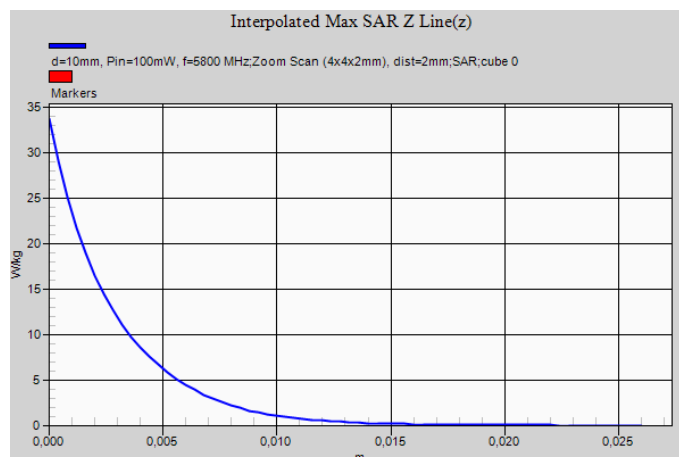

Appendix E – Calibration data



Accredited by the Swiss Accreditation Service (SAS)
The Swiss Accreditation Service is one of the signatories to the EA
Multilateral Agreement for the recognition of calibration certificates

Accreditation No.: **SCS 108**

Client **AT4 Wireless**

Certificate No: **DAE4-669_Jul14**

CALIBRATION CERTIFICATE

Object **DAE4 - SD 000 D04 BM - SN: 669**

Calibration procedure(s) **QA CAL-06.v26
Calibration procedure for the data acquisition electronics (DAE)**

Calibration date: **July 08, 2014**

This calibration certificate documents the traceability to national standards, which realize the physical units of measurements (SI).
The measurements and the uncertainties with confidence probability are given on the following pages and are part of the certificate.

All calibrations have been conducted in the closed laboratory facility: environment temperature (22 ± 3)°C and humidity < 70%.

Calibration Equipment used (M&TE critical for calibration)

Primary Standards	ID #	Cal Date (Certificate No.)	Scheduled Calibration
Keithley Multimeter Type 2001	SN: 0810278	01-Oct-13 (No:13976)	Oct-14
Secondary Standards	ID #	Check Date (in house)	Scheduled Check
Auto DAE Calibration Unit	SE UWS 053 AA 1001	07-Jan-14 (in house check)	In house check: Jan-15
Calibrator Box V2.1	SE UMS 006 AA 1002	07-Jan-14 (in house check)	In house check: Jan-15

	Name	Function	Signature
Calibrated by:	Dominique Steffen	Technician	
Approved by:	Fin Bomholt	Deputy Technical Manager	

Issued: July 8, 2014

This calibration certificate shall not be reproduced except in full without written approval of the laboratory.



Accredited by the Swiss Accreditation Service (SAS)
The Swiss Accreditation Service is one of the signatories to the EA
Multilateral Agreement for the recognition of calibration certificates

Accreditation No.: **SCS 108**

Glossary

DAE data acquisition electronics
Connector angle information used in DASY system to align probe sensor X to the robot coordinate system.

Methods Applied and Interpretation of Parameters

- *DC Voltage Measurement:* Calibration Factor assessed for use in DASY system by comparison with a calibrated instrument traceable to national standards. The figure given corresponds to the full scale range of the voltmeter in the respective range.
- *Connector angle:* The angle of the connector is assessed measuring the angle mechanically by a tool inserted. Uncertainty is not required.
- The following parameters as documented in the Appendix contain technical information as a result from the performance test and require no uncertainty.
 - *DC Voltage Measurement Linearity:* Verification of the Linearity at +10% and -10% of the nominal calibration voltage. Influence of offset voltage is included in this measurement.
 - *Common mode sensitivity:* Influence of a positive or negative common mode voltage on the differential measurement.
 - *Channel separation:* Influence of a voltage on the neighbor channels not subject to an input voltage.
 - *AD Converter Values with inputs shorted:* Values on the internal AD converter corresponding to zero input voltage
 - *Input Offset Measurement:* Output voltage and statistical results over a large number of zero voltage measurements.
 - *Input Offset Current:* Typical value for information; Maximum channel input offset current, not considering the input resistance.
 - *Input resistance:* Typical value for information: DAE input resistance at the connector, during internal auto-zeroing and during measurement.
 - *Low Battery Alarm Voltage:* Typical value for information. Below this voltage, a battery alarm signal is generated.
 - *Power consumption:* Typical value for information. Supply currents in various operating modes.

DC Voltage Measurement

A/D - Converter Resolution nominal

High Range: 1LSB = 6.1 μ V, full range = -100...+300 mV
Low Range: 1LSB = 61nV, full range = -1.....+3mV

DASY measurement parameters: Auto Zero Time: 3 sec; Measuring time: 3 sec

Calibration Factors	X	Y	Z
High Range	403.321 \pm 0.02% (k=2)	403.870 \pm 0.02% (k=2)	404.236 \pm 0.02% (k=2)
Low Range	3.95654 \pm 1.50% (k=2)	3.97463 \pm 1.50% (k=2)	3.97450 \pm 1.50% (k=2)

Connector Angle

Connector Angle to be used in DASY system	193.0 \pm 1 $^{\circ}$
---	--------------------------

Appendix (Additional assessments outside the scope of SCS108)

1. DC Voltage Linearity

High Range	Reading (μV)	Difference (μV)	Error (%)
Channel X + Input	199998.19	1.59	0.00
Channel X + Input	20005.64	5.16	0.03
Channel X - Input	-19996.31	4.81	-0.02
Channel Y + Input	199995.73	-1.00	-0.00
Channel Y + Input	20004.06	3.54	0.02
Channel Y - Input	-19997.93	3.28	-0.02
Channel Z + Input	199997.38	0.79	0.00
Channel Z + Input	20004.17	3.55	0.02
Channel Z - Input	-19997.90	3.31	-0.02

Low Range	Reading (μV)	Difference (μV)	Error (%)
Channel X + Input	2000.84	0.28	0.01
Channel X + Input	201.50	0.42	0.21
Channel X - Input	-197.83	0.90	-0.45
Channel Y + Input	2001.06	0.57	0.03
Channel Y + Input	200.71	-0.32	-0.16
Channel Y - Input	-199.39	-0.60	0.30
Channel Z + Input	2001.12	0.68	0.03
Channel Z + Input	199.84	-1.25	-0.62
Channel Z - Input	-200.65	-1.79	0.90

2. Common mode sensitivity

DASY measurement parameters: Auto Zero Time: 3 sec; Measuring time: 3 sec

	Common mode Input Voltage (mV)	High Range Average Reading (μV)	Low Range Average Reading (μV)
Channel X	200	2.02	0.88
	- 200	1.03	-0.74
Channel Y	200	11.55	10.93
	- 200	-12.37	-12.38
Channel Z	200	-9.56	-9.90
	- 200	8.49	8.06

3. Channel separation

DASY measurement parameters: Auto Zero Time: 3 sec; Measuring time: 3 sec

	Input Voltage (mV)	Channel X (μV)	Channel Y (μV)	Channel Z (μV)
Channel X	200	-	-2.27	-2.78
Channel Y	200	9.49	-	-1.75
Channel Z	200	3.99	7.50	-

4. AD-Converter Values with inputs shorted

DASY measurement parameters: Auto Zero Time: 3 sec; Measuring time: 3 sec

	High Range (LSB)	Low Range (LSB)
Channel X	16079	16148
Channel Y	15795	15263
Channel Z	15997	15243

5. Input Offset Measurement

DASY measurement parameters: Auto Zero Time: 3 sec; Measuring time: 3 sec

Input 10M Ω

	Average (μ V)	min. Offset (μ V)	max. Offset (μ V)	Std. Deviation (μ V)
Channel X	0.48	-0.54	1.65	0.44
Channel Y	-0.35	-1.84	1.53	0.54
Channel Z	0.15	-1.16	0.99	0.42

6. Input Offset Current

Nominal Input circuitry offset current on all channels: <25fA

7. Input Resistance (Typical values for information)

	Zeroing (kOhm)	Measuring (MOhm)
Channel X	200	200
Channel Y	200	200
Channel Z	200	200

8. Low Battery Alarm Voltage (Typical values for information)

Typical values	Alarm Level (VDC)
Supply (+ Vcc)	+7.9
Supply (- Vcc)	-7.6

9. Power Consumption (Typical values for information)

Typical values	Switched off (mA)	Stand by (mA)	Transmitting (mA)
Supply (+ Vcc)	+0.01	+6	+14
Supply (- Vcc)	-0.01	-8	-9



Accredited by the Swiss Accreditation Service (SAS)
The Swiss Accreditation Service is one of the signatories to the EA
Multilateral Agreement for the recognition of calibration certificates

Accreditation No.: **SCS 108**

Client **AT4 Wireless**

Certificate No: **ES3-3052_Sep14**

CALIBRATION CERTIFICATE

Object **ES3DV3 - SN:3052**

Calibration procedure(s) **QA CAL-01.v9, QA CAL-23.v5, QA CAL-25.v6
Calibration procedure for dosimetric E-field probes**

Calibration date: **September 24, 2014**

This calibration certificate documents the traceability to national standards, which realize the physical units of measurements (SI).
The measurements and the uncertainties with confidence probability are given on the following pages and are part of the certificate.

All calibrations have been conducted in the closed laboratory facility: environment temperature (22 ± 3)°C and humidity < 70%.

Calibration Equipment used (M&TE critical for calibration)

Primary Standards	ID	Cal Date (Certificate No.)	Scheduled Calibration
Power meter E4419B	GB41293874	03-Apr-14 (No. 217-01911)	Apr-15
Power sensor E4412A	MY41498087	03-Apr-14 (No. 217-01911)	Apr-15
Reference 3 dB Attenuator	SN: S5054 (3c)	03-Apr-14 (No. 217-01915)	Apr-15
Reference 20 dB Attenuator	SN: S5277 (20x)	03-Apr-14 (No. 217-01919)	Apr-15
Reference 30 dB Attenuator	SN: S5129 (30b)	03-Apr-14 (No. 217-01920)	Apr-15
Reference Probe ES3DV2	SN: 3013	30-Dec-13 (No. ES3-3013_Dec13)	Dec-14
DAE4	SN: 660	13-Dec-13 (No. DAE4-660_Dec13)	Dec-14
Secondary Standards	ID	Check Date (in house)	Scheduled Check
RF generator HP 8648C	US3642U01700	4-Aug-99 (in house check Apr-13)	In house check: Apr-16
Network Analyzer HP 8753E	US37390585	18-Oct-01 (in house check Oct-13)	In house check: Oct-14

	Name	Function	Signature
Calibrated by:	Leif Klynsner	Laboratory Technician	
Approved by:	Katja Pokovic	Technical Manager	

Issued: September 24, 2014

This calibration certificate shall not be reproduced except in full without written approval of the laboratory.



Accredited by the Swiss Accreditation Service (SAS)

Accreditation No.: **SCS 108**

The Swiss Accreditation Service is one of the signatories to the EA Multilateral Agreement for the recognition of calibration certificates

Glossary:

TSL	tissue simulating liquid
NORM _{x,y,z}	sensitivity in free space
ConvF	sensitivity in TSL / NORM _{x,y,z}
DCP	diode compression point
CF	crest factor (1/duty_cycle) of the RF signal
A, B, C, D	modulation dependent linearization parameters
Polarization ϕ	ϕ rotation around probe axis
Polarization ϑ	ϑ rotation around an axis that is in the plane normal to probe axis (at measurement center), i.e., $\vartheta = 0$ is normal to probe axis
Connector Angle	information used in DASY system to align probe sensor X to the robot coordinate system

Calibration is Performed According to the Following Standards:

- a) IEEE Std 1528-2013, "IEEE Recommended Practice for Determining the Peak Spatial-Averaged Specific Absorption Rate (SAR) in the Human Head from Wireless Communications Devices: Measurement Techniques", June 2013
- b) IEC 62209-1, "Procedure to measure the Specific Absorption Rate (SAR) for hand-held devices used in close proximity to the ear (frequency range of 300 MHz to 3 GHz)", February 2005

Methods Applied and Interpretation of Parameters:

- *NORM_{x,y,z}*: Assessed for E-field polarization $\vartheta = 0$ ($f \leq 900$ MHz in TEM-cell; $f > 1800$ MHz: R22 waveguide). *NORM_{x,y,z}* are only intermediate values, i.e., the uncertainties of *NORM_{x,y,z}* does not affect the E^2 -field uncertainty inside TSL (see below *ConvF*).
- *NORM(f)_{x,y,z}* = *NORM_{x,y,z}* * *frequency_response* (see Frequency Response Chart). This linearization is implemented in DASY4 software versions later than 4.2. The uncertainty of the frequency response is included in the stated uncertainty of *ConvF*.
- *DCP_{x,y,z}*: DCP are numerical linearization parameters assessed based on the data of power sweep with CW signal (no uncertainty required). DCP does not depend on frequency nor media.
- *PAR*: PAR is the Peak to Average Ratio that is not calibrated but determined based on the signal characteristics
- *A_{x,y,z}*; *B_{x,y,z}*; *C_{x,y,z}*; *D_{x,y,z}*; *VR_{x,y,z}*; *A, B, C, D* are numerical linearization parameters assessed based on the data of power sweep for specific modulation signal. The parameters do not depend on frequency nor media. *VR* is the maximum calibration range expressed in RMS voltage across the diode.
- *ConvF and Boundary Effect Parameters*: Assessed in flat phantom using E-field (or Temperature Transfer Standard for $f \leq 800$ MHz) and inside waveguide using analytical field distributions based on power measurements for $f > 800$ MHz. The same setups are used for assessment of the parameters applied for boundary compensation (alpha, depth) of which typical uncertainty values are given. These parameters are used in DASY4 software to improve probe accuracy close to the boundary. The sensitivity in TSL corresponds to *NORM_{x,y,z}* * *ConvF* whereby the uncertainty corresponds to that given for *ConvF*. A frequency dependent *ConvF* is used in DASY version 4.4 and higher which allows extending the validity from ± 50 MHz to ± 100 MHz.
- *Spherical isotropy (3D deviation from isotropy)*: in a field of low gradients realized using a flat phantom exposed by a patch antenna.
- *Sensor Offset*: The sensor offset corresponds to the offset of virtual measurement center from the probe tip (on probe axis). No tolerance required.
- *Connector Angle*: The angle is assessed using the information gained by determining the *NORM_x* (no uncertainty required).

Probe ES3DV3

SN:3052

Manufactured: September 30, 2003
Repaired: September 18, 2014
Calibrated: September 24, 2014

Calibrated for DASYS/EASY Systems
(Note: non-compatible with DASYS2 system!)

DASY/EASY - Parameters of Probe: ES3DV3 - SN:3052

Basic Calibration Parameters

	Sensor X	Sensor Y	Sensor Z	Unc (k=2)
Norm ($\mu\text{V}/(\text{V}/\text{m})^2$) ^A	1.13	0.42	1.10	$\pm 10.1\%$
DCP (mV) ^B	104.3	98.3	102.9	

Modulation Calibration Parameters

UID	Communication System Name		A dB	B dB $\sqrt{\mu\text{V}}$	C	D dB	VR mV	Unc ^E (k=2)
0	CW	X	0.0	0.0	1.0	0.00	199.5	$\pm 3.5\%$
		Y	0.0	0.0	1.0		180.7	
		Z	0.0	0.0	1.0		199.0	
10011- CAB	UMTS-FDD (WCDMA)	X	3.36	67.7	18.9	2.91	136.2	$\pm 0.7\%$
		Y	3.05	64.3	16.5		144.5	
		Z	3.24	66.7	18.2		136.3	
10012- CAA	IEEE 802.11b WiFi 2.4 GHz (DSSS, 1 Mbps)	X	2.93	69.1	19.0	1.87	138.2	$\pm 0.7\%$
		Y	2.41	64.0	15.8		143.3	
		Z	2.90	68.5	18.4		137.9	
10013- CAA	IEEE 802.11g WiFi 2.4 GHz (DSSS-OFDM, 6 Mbps)	X	11.13	70.8	23.4	9.46	135.8	$\pm 3.3\%$
		Y	10.99	69.1	21.9		143.7	
		Z	11.06	70.4	23.1		135.3	
10021- DAB	GSM-FDD (TDMA, GMSK)	X	10.62	86.4	23.2	9.39	144.0	$\pm 1.9\%$
		Y	2.75	68.5	16.2		87.9	
		Z	17.37	95.8	26.8		144.4	
10023- DAB	GPRS-FDD (TDMA, GMSK, TN 0)	X	15.14	93.2	25.8	9.57	145.2	$\pm 2.2\%$
		Y	2.61	67.2	15.9		82.8	
		Z	19.74	98.0	27.4		130.3	
10024- DAB	GPRS-FDD (TDMA, GMSK, TN 0-1)	X	32.39	99.8	25.1	6.56	128.1	$\pm 1.4\%$
		Y	4.81	76.8	17.9		126.8	
		Z	34.20	99.8	25.0		141.2	
10025- DAB	EDGE-FDD (TDMA, 8PSK, TN 0)	X	13.71	99.1	38.4	12.62	139.8	$\pm 3.0\%$
		Y	4.87	67.9	23.1		59.1	
		Z	13.94	99.6	38.7		126.3	
10026- DAB	EDGE-FDD (TDMA, 8PSK, TN 0-1)	X	11.01	90.1	31.4	9.55	126.7	$\pm 2.5\%$
		Y	5.75	74.5	24.4		124.5	
		Z	12.89	93.9	33.0		139.8	
10027- DAB	GPRS-FDD (TDMA, GMSK, TN 0-1-2)	X	32.71	94.5	21.4	4.80	144.2	$\pm 1.4\%$
		Y	2.79	69.7	13.7		132.6	
		Z	50.44	99.9	22.9		130.7	
10028- DAB	GPRS-FDD (TDMA, GMSK, TN 0-1-2-3)	X	47.66	99.5	22.1	3.55	126.6	$\pm 2.2\%$
		Y	24.59	92.3	19.6		146.3	
		Z	55.77	99.6	21.9		143.7	
10029- DAB	EDGE-FDD (TDMA, 8PSK, TN 0-1-2)	X	16.20	99.3	33.6	7.78	147.3	$\pm 3.3\%$
		Y	5.14	72.9	22.5		132.6	
		Z	10.86	89.3	29.7		137.0	

10048-CAA	DECT (TDD, TDMA/FDM, GFSK, Full Slot, 24)	X	7.45	83.0	25.7	13.80	90.0	±1.9 %
		Y	2.39	62.3	15.5		32.0	
		Z	7.27	82.6	25.8		84.7	
10049-CAA	DECT (TDD, TDMA/FDM, GFSK, Double Slot, 12)	X	13.92	91.7	26.1	10.79	148.8	±1.7 %
		Y	3.21	69.9	17.8		65.7	
		Z	14.37	92.6	26.6		138.7	
10058-DAB	EDGE-FDD (TDMA, 8PSK, TN 0-1-2-3)	X	7.02	80.2	25.3	6.52	128.8	±2.2 %
		Y	5.09	73.7	22.3		141.9	
		Z	14.75	96.3	31.4		144.1	
10098-CAB	UMTS-FDD (HSUPA, Subtest 2)	X	4.49	66.4	18.4	3.98	127.8	±0.9 %
		Y	4.51	65.2	17.4		150.0	
		Z	4.62	66.8	18.7		140.4	
10100-CAB	LTE-FDD (SC-FDMA, 100% RB, 20 MHz, QPSK)	X	6.34	67.3	19.6	5.67	134.3	±1.4 %
		Y	6.31	66.1	18.5		134.8	
		Z	6.54	68.0	20.0		148.0	
10102-CAB	LTE-FDD (SC-FDMA, 100% RB, 20 MHz, 64-QAM)	X	7.72	67.9	20.3	6.60	147.1	±1.9 %
		Y	7.76	66.9	19.3		148.6	
		Z	7.62	67.5	20.1		134.4	
10101-CAB	LTE-FDD (SC-FDMA, 100% RB, 20 MHz, 16-QAM)	X	7.72	67.9	20.3	6.42	147.1	±12.2 %
		Y	7.76	66.9	19.3		148.6	
		Z	7.62	67.5	20.1		134.4	
10110-CAB	LTE-FDD (SC-FDMA, 100% RB, 5 MHz, QPSK)	X	5.87	66.2	19.2	5.75	129.6	±1.4 %
		Y	5.91	65.3	18.3		130.0	
		Z	6.06	67.0	19.7		141.4	
10154-CAB	LTE-FDD (SC-FDMA, 50% RB, 10 MHz, QPSK)	X	5.87	66.2	19.2	5.75	129.6	±12.2 %
		Y	5.91	65.3	18.3		130.0	
		Z	6.06	67.0	19.7		141.4	
10112-CAB	LTE-FDD (SC-FDMA, 100% RB, 10 MHz, 64-QAM)	X	7.44	67.6	20.2	6.59	142.4	±1.9 %
		Y	7.48	66.6	19.2		144.0	
		Z	7.35	67.3	20.0		130.5	
10109-CAB	LTE-FDD (SC-FDMA, 100% RB, 10 MHz, 16-QAM)	X	7.44	67.6	20.2	6.43	142.4	±12.2 %
		Y	7.48	66.6	19.2		144.0	
		Z	7.35	67.3	20.0		130.5	
10150-CAB	LTE-FDD (SC-FDMA, 50% RB, 20 MHz, 64-QAM)	X	7.44	67.6	20.2	6.60	142.4	±12.2 %
		Y	7.48	66.6	19.2		144.0	
		Z	7.35	67.3	20.0		130.5	
10149-CAB	LTE-FDD (SC-FDMA, 50% RB, 20 MHz, 16-QAM)	X	7.44	67.6	20.2	6.42	142.4	±12.2 %
		Y	7.48	66.6	19.2		144.0	
		Z	7.35	67.3	20.0		130.5	
10117-CAA	IEEE 802.11n (HT Mixed, 13.5 Mbps, BPSK)	X	10.44	69.6	21.7	8.07	149.5	±2.7 %
		Y	10.10	67.7	20.2		124.9	
		Z	10.31	69.2	21.5		136.0	
10140-CAB	LTE-FDD (SC-FDMA, 100% RB, 15 MHz, 16-QAM)	X	7.66	68.0	20.2	6.49	147.5	±1.7 %
		Y	7.46	66.2	18.9		124.4	
		Z	7.58	67.6	20.1		134.6	

10141-CAB	LTE-FDD (SC-FDMA, 100% RB, 15 MHz, 64-QAM)	X	7.66	68.0	20.2	6.53	147.5	±12.2 %
		Y	7.46	66.2	18.9		124.4	
		Z	7.58	67.6	20.1		134.6	
10146-CAB	LTE-FDD (SC-FDMA, 100% RB, 1.4 MHz, 16-QAM)	X	6.36	66.9	19.8	6.41	127.6	±1.4 %
		Y	6.30	65.7	18.7		128.9	
		Z	6.55	67.6	20.2		139.3	
10147-CAB	LTE-FDD (SC-FDMA, 100% RB, 1.4 MHz, 64-QAM)	X	6.63	67.1	20.0	6.72	127.1	±1.7 %
		Y	6.58	65.9	19.0		128.3	
		Z	6.83	67.8	20.5		139.2	
10157-CAB	LTE-FDD (SC-FDMA, 50% RB, 5 MHz, 16-QAM)	X	6.62	66.8	19.8	6.49	130.4	±1.7 %
		Y	6.65	65.8	18.9		133.0	
		Z	6.83	67.5	20.2		142.9	
10158-CAB	LTE-FDD (SC-FDMA, 50% RB, 10 MHz, 64-QAM)	X	7.15	67.3	20.0	6.62	137.7	±1.9 %
		Y	7.22	66.4	19.2		140.7	
		Z	7.05	66.9	19.9		125.4	
10111-CAB	LTE-FDD (SC-FDMA, 100% RB, 5 MHz, 16-QAM)	X	7.15	67.3	20.0	6.44	137.7	±12.2 %
		Y	7.22	66.4	19.2		140.7	
		Z	7.05	66.9	19.9		125.4	
10113-CAB	LTE-FDD (SC-FDMA, 100% RB, 5 MHz, 64-QAM)	X	7.15	67.3	20.0	6.62	137.7	±12.2 %
		Y	7.22	66.4	19.2		140.7	
		Z	7.05	66.9	19.9		125.4	
10155-CAB	LTE-FDD (SC-FDMA, 50% RB, 10 MHz, 16-QAM)	X	7.15	67.3	20.0	6.43	137.7	±12.2 %
		Y	7.22	66.4	19.2		140.7	
		Z	7.05	66.9	19.9		125.4	
10161-CAB	LTE-FDD (SC-FDMA, 50% RB, 15 MHz, 16-QAM)	X	7.15	67.3	20.0	6.43	137.7	±12.2 %
		Y	7.22	66.4	19.2		140.7	
		Z	7.05	66.9	19.9		125.4	
10162-CAB	LTE-FDD (SC-FDMA, 50% RB, 15 MHz, 64-QAM)	X	7.15	67.3	20.0	6.58	137.7	±12.2 %
		Y	7.22	66.4	19.2		140.7	
		Z	7.05	66.9	19.9		125.4	
10159-CAB	LTE-FDD (SC-FDMA, 50% RB, 5 MHz, 64-QAM)	X	6.78	67.1	20.0	6.56	132.1	±1.9 %
		Y	6.79	66.1	19.0		135.6	
		Z	6.97	67.8	20.4		144.2	
10173-CAB	LTE-TDD (SC-FDMA, 1 RB, 20 MHz, 16-QAM)	X	8.21	77.1	27.3	9.48	128.8	±2.7 %
		Y	6.63	70.6	23.3		143.3	
		Z	9.09	80.2	29.0		142.6	
10226-CAA	LTE-TDD (SC-FDMA, 1 RB, 1.4 MHz, 16-QAM)	X	8.21	77.1	27.3	9.49	128.8	±12.2 %
		Y	6.63	70.6	23.3		143.3	
		Z	9.09	80.2	29.0		142.6	
10235-CAB	LTE-TDD (SC-FDMA, 1 RB, 10 MHz, 16-QAM)	X	8.21	77.1	27.3	9.48	128.8	±12.2 %
		Y	6.63	70.6	23.3		143.3	
		Z	9.09	80.2	29.0		142.6	
10229-CAB	LTE-TDD (SC-FDMA, 1 RB, 3 MHz, 16-QAM)	X	8.21	77.1	27.3	9.48	128.8	±12.2 %
		Y	6.63	70.6	23.3		143.3	
		Z	9.09	80.2	29.0		142.6	

10232-CAB	LTE-TDD (SC-FDMA, 1 RB, 5 MHz, 16-QAM)	X	8.21	77.1	27.3	9.48	128.8	±12.2 %
		Y	6.63	70.6	23.3		143.3	
		Z	9.09	80.2	29.0		142.6	
10238-CAB	LTE-TDD (SC-FDMA, 1 RB, 15 MHz, 16-QAM)	X	8.21	77.1	27.3	9.48	128.8	±12.2 %
		Y	6.63	70.6	23.3		143.3	
		Z	9.09	80.2	29.0		142.6	
10179-CAB	LTE-FDD (SC-FDMA, 1 RB, 10 MHz, 64-QAM)	X	5.61	67.5	20.4	6.50	131.2	±1.9 %
		Y	5.52	66.6	19.5		149.2	
		Z	5.78	68.2	20.8		142.1	
10170-CAB	LTE-FDD (SC-FDMA, 1 RB, 20 MHz, 16-QAM)	X	5.61	67.5	20.4	6.52	131.2	±12.2 %
		Y	5.52	66.6	19.5		149.2	
		Z	5.78	68.2	20.8		142.1	
10176-CAB	LTE-FDD (SC-FDMA, 1 RB, 10 MHz, 16-QAM)	X	5.61	67.5	20.4	6.52	131.2	±12.2 %
		Y	5.52	66.6	19.5		149.2	
		Z	5.78	68.2	20.8		142.1	
10188-CAB	LTE-FDD (SC-FDMA, 1 RB, 1.4 MHz, 16-QAM)	X	5.61	67.5	20.4	6.52	131.2	±12.2 %
		Y	5.52	66.6	19.5		149.2	
		Z	5.78	68.2	20.8		142.1	
10180-CAB	LTE-FDD (SC-FDMA, 1 RB, 5 MHz, 64-QAM)	X	5.61	67.5	20.4	6.50	131.2	±12.2 %
		Y	5.52	66.6	19.5		149.2	
		Z	5.78	68.2	20.8		142.1	
10178-CAB	LTE-FDD (SC-FDMA, 1 RB, 5 MHz, 16-QAM)	X	5.61	67.5	20.4	6.52	131.2	±12.2 %
		Y	5.52	66.6	19.5		149.2	
		Z	5.78	68.2	20.8		142.1	
10182-CAB	LTE-FDD (SC-FDMA, 1 RB, 15 MHz, 16-QAM)	X	5.61	67.5	20.4	6.52	131.2	±12.2 %
		Y	5.52	66.6	19.5		149.2	
		Z	5.78	68.2	20.8		142.1	
10185-CAB	LTE-FDD (SC-FDMA, 1 RB, 3 MHz, 16-QAM)	X	5.61	67.5	20.4	6.51	131.2	±12.2 %
		Y	5.52	66.6	19.5		149.2	
		Z	5.78	68.2	20.8		142.1	
10187-CAB	LTE-FDD (SC-FDMA, 1 RB, 1.4 MHz, QPSK)	X	4.91	66.6	19.6	5.73	132.5	±1.7 %
		Y	4.82	65.4	18.6		149.1	
		Z	5.03	67.1	19.9		144.0	
10166-CAB	LTE-FDD (SC-FDMA, 50% RB, 1.4 MHz, QPSK)	X	4.91	66.6	19.6	5.46	132.5	±12.2 %
		Y	4.82	65.4	18.6		149.1	
		Z	5.03	67.1	19.9		144.0	
10181-CAB	LTE-FDD (SC-FDMA, 1 RB, 15 MHz, QPSK)	X	4.91	66.6	19.6	5.72	132.5	±12.2 %
		Y	4.82	65.4	18.6		149.1	
		Z	5.03	67.1	19.9		144.0	
10169-CAB	LTE-FDD (SC-FDMA, 1 RB, 20 MHz, QPSK)	X	4.91	66.6	19.6	5.73	132.5	±12.2 %
		Y	4.82	65.4	18.6		149.1	
		Z	5.03	67.1	19.9		144.0	
10175-CAB	LTE-FDD (SC-FDMA, 1 RB, 10 MHz, QPSK)	X	4.91	66.6	19.6	5.72	132.5	±12.2 %
		Y	4.82	65.4	18.6		149.1	
		Z	5.03	67.1	19.9		144.0	

10177-CAD	LTE-FDD (SC-FDMA, 1 RB, 5 MHz, QPSK)	X	4.91	66.6	19.6	5.73	132.5	±12.2 %
		Y	4.82	65.4	18.6		149.1	
		Z	5.03	67.1	19.9		144.0	
10184-CAB	LTE-FDD (SC-FDMA, 1 RB, 3 MHz, QPSK)	X	4.91	66.6	19.6	5.73	132.5	±12.2 %
		Y	4.82	65.4	18.6		149.1	
		Z	5.03	67.1	19.9		144.0	
10196-CAA	IEEE 802.11n (HT Mixed, 6.5 Mbps, BPSK)	X	9.98	69.0	21.5	8.10	140.6	±2.7 %
		Y	10.10	68.2	20.6		140.7	
		Z	9.90	68.8	21.4		129.4	
10225-CAB	UMTS-FDD (HSPA+)	X	6.99	67.1	19.5	5.97	143.6	±1.4 %
		Y	7.11	66.4	18.8		149.0	
		Z	6.91	66.8	19.3		133.0	
10228-CAA	LTE-TDD (SC-FDMA, 1 RB, 1.4 MHz, QPSK)	X	8.00	76.7	27.1	9.22	132.0	±2.7 %
		Y	6.43	70.1	23.1		147.2	
		Z	8.85	79.7	28.7		146.7	
10237-CAB	LTE-TDD (SC-FDMA, 1 RB, 10 MHz, QPSK)	X	8.00	76.7	27.1	9.21	132.0	±12.2 %
		Y	6.43	70.1	23.1		147.2	
		Z	8.85	79.7	28.7		146.7	
10172-CAB	LTE-TDD (SC-FDMA, 1 RB, 20 MHz, QPSK)	X	8.00	76.7	27.1	9.21	132.0	±12.2 %
		Y	6.43	70.1	23.1		147.2	
		Z	8.85	79.7	28.7		146.7	
10231-CAB	LTE-TDD (SC-FDMA, 1 RB, 3 MHz, QPSK)	X	8.00	76.7	27.1	9.19	132.0	±12.2 %
		Y	6.43	70.1	23.1		147.2	
		Z	8.85	79.7	28.7		146.7	
10234-CAB	LTE-TDD (SC-FDMA, 1 RB, 5 MHz, QPSK)	X	8.00	76.7	27.1	9.21	132.0	±12.2 %
		Y	6.43	70.1	23.1		147.2	
		Z	8.85	79.7	28.7		146.7	
10240-CAB	LTE-TDD (SC-FDMA, 1 RB, 15 MHz, QPSK)	X	8.00	76.7	27.1	9.21	132.0	±12.2 %
		Y	6.43	70.1	23.1		147.2	
		Z	8.85	79.7	28.7		146.7	
10246-CAB	LTE-TDD (SC-FDMA, 50% RB, 3 MHz, QPSK)	X	8.24	73.2	25.3	9.30	124.9	±3.8 %
		Y	7.22	68.4	22.2		139.6	
		Z	8.98	75.8	26.8		140.1	
10249-CAB	LTE-TDD (SC-FDMA, 50% RB, 5 MHz, QPSK)	X	8.24	73.2	25.3	9.29	124.9	±12.2 %
		Y	7.22	68.4	22.2		139.6	
		Z	8.98	75.8	26.8		140.1	
10258-CAA	LTE-TDD (SC-FDMA, 100% RB, 1.4 MHz, QPSK)	X	8.24	73.2	25.3	9.34	124.9	±12.2 %
		Y	7.22	68.4	22.2		139.6	
		Z	8.98	75.8	26.8		140.1	
10256-CAA	LTE-TDD (SC-FDMA, 100% RB, 1.4 MHz, 16-QAM)	X	9.05	73.9	26.0	9.96	128.6	±3.8 %
		Y	8.03	69.3	22.9		146.6	
		Z	9.83	76.5	27.6		144.6	
10247-CAB	LTE-TDD (SC-FDMA, 50% RB, 5 MHz, 16-QAM)	X	9.05	73.9	26.0	9.91	128.6	±12.2 %
		Y	8.03	69.3	22.9		146.6	
		Z	9.83	76.5	27.6		144.6	

10244-CAB	LTE-TDD (SC-FDMA, 50% RB, 3 MHz, 16-QAM)	X	9.05	73.9	26.0	10.06	128.6	±12.2 %
		Y	8.03	69.3	22.9		146.6	
		Z	9.83	76.5	27.6		144.6	
10262-CAB	LTE-TDD (SC-FDMA, 100% RB, 5 MHz, 16-QAM)	X	10.05	74.8	26.4	9.83	145.4	±3.3 %
		Y	8.44	68.3	22.1		138.9	
		Z	9.81	74.1	26.1		133.2	
10250-CAB	LTE-TDD (SC-FDMA, 50% RB, 10 MHz, 16-QAM)	X	10.05	74.8	26.4	9.81	145.4	±12.2 %
		Y	8.44	68.3	22.1		138.9	
		Z	9.81	74.1	26.1		133.2	
10259-CAB	LTE-TDD (SC-FDMA, 100% RB, 3 MHz, 16-QAM)	X	10.05	74.8	26.4	9.98	145.4	±12.2 %
		Y	8.44	68.3	22.1		138.9	
		Z	9.81	74.1	26.1		133.2	
10264-CAB	LTE-TDD (SC-FDMA, 100% RB, 5 MHz, QPSK)	X	9.03	74.4	25.8	9.23	135.1	±3.3 %
		Y	7.47	67.7	21.5		132.4	
		Z	8.83	73.7	25.5		124.7	
10252-CAB	LTE-TDD (SC-FDMA, 50% RB, 10 MHz, QPSK)	X	9.03	74.4	25.8	9.24	135.1	±12.2 %
		Y	7.47	67.7	21.5		132.4	
		Z	8.83	73.7	25.5		124.7	
10261-CAB	LTE-TDD (SC-FDMA, 100% RB, 3 MHz, QPSK)	X	9.03	74.4	25.8	9.24	135.1	±12.2 %
		Y	7.47	67.7	21.5		132.4	
		Z	8.83	73.7	25.5		124.7	
10265-CAB	LTE-TDD (SC-FDMA, 100% RB, 10 MHz, 16-QAM)	X	9.82	72.7	25.2	9.92	127.0	±3.8 %
		Y	8.92	68.6	22.3		145.9	
		Z	10.52	74.9	26.6		142.0	
10152-CAB	LTE-TDD (SC-FDMA, 50% RB, 20 MHz, 16-QAM)	X	9.82	72.7	25.2	9.92	127.0	±12.2 %
		Y	8.92	68.6	22.3		145.9	
		Z	10.52	74.9	26.6		142.0	
10267-CAB	LTE-TDD (SC-FDMA, 100% RB, 10 MHz, QPSK)	X	9.90	75.7	26.4	9.30	144.2	±3.5 %
		Y	7.92	68.2	21.7		136.6	
		Z	9.53	74.6	25.9		131.7	
10151-CAB	LTE-TDD (SC-FDMA, 50% RB, 20 MHz, QPSK)	X	9.90	75.7	26.4	9.28	144.2	±12.2 %
		Y	7.92	68.2	21.7		136.6	
		Z	9.53	74.6	25.9		131.7	
10297-AAA	LTE-FDD (SC-FDMA, 50% RB, 20 MHz, QPSK)	X	6.25	67.0	19.6	5.81	133.5	±1.4 %
		Y	6.26	65.9	18.6		134.7	
		Z	6.44	67.6	19.9		147.8	
10299-AAA	LTE-FDD (SC-FDMA, 50% RB, 3 MHz, 16-QAM)	X	6.52	67.2	19.9	6.39	130.9	±1.7 %
		Y	6.48	66.0	18.9		130.5	
		Z	6.68	67.7	20.2		144.1	
10300-AAA	LTE-FDD (SC-FDMA, 50% RB, 3 MHz, 64-QAM)	X	6.71	67.2	20.0	6.60	131.2	±1.7 %
		Y	6.66	66.0	19.0		129.6	
		Z	6.89	67.9	20.4		143.8	
10415-AAA	IEEE 802.11b WiFi 2.4 GHz (DSSS, 1 Mbps, 99pc duty cycle)	X	2.67	68.6	18.7	1.54	145.7	±0.5 %
		Y	2.30	64.3	16.0		141.9	
		Z	2.54	67.4	18.1		135.2	

10416-AAA	IEEE 802.11g WiFi 2.4 GHz (ERP-OFDM, 6 Mbps, 99pc duty cycle)	X	10.13	69.3	21.7	8.23	143.5	±2.7 %
		Y	10.20	68.2	20.7		142.2	
		Z	10.02	68.9	21.5		131.6	
10418-AAA	IEEE 802.11g WiFi 2.4 GHz (DSSS-OFDM, 6 Mbps, 99pc duty cycle, Long preamble)	X	10.01	69.2	21.6	8.14	142.9	±2.5 %
		Y	10.10	68.3	20.7		142.3	
		Z	9.92	69.0	21.6		132.0	
10419-AAA	IEEE 802.11g WiFi 2.4 GHz (DSSS-OFDM, 6 Mbps, 99pc duty cycle, Short preamble)	X	10.08	69.2	21.7	8.19	144.0	±2.7 %
		Y	10.19	68.3	20.8		143.7	
		Z	10.00	69.0	21.6		132.9	

The reported uncertainty of measurement is stated as the standard uncertainty of measurement multiplied by the coverage factor $k=2$, which for a normal distribution corresponds to a coverage probability of approximately 95%.

^A The uncertainties of NormX,Y,Z do not affect the E^2 -field uncertainty inside TSL (see Pages 11 and 12).

^B Numerical linearization parameter: uncertainty not required.

^E Uncertainty is determined using the max. deviation from linear response applying rectangular distribution and is expressed for the square of the field value.

DASY/EASY - Parameters of Probe: ES3DV3 - SN:3052

Calibration Parameter Determined in Head Tissue Simulating Media

f (MHz) ^C	Relative Permittivity ^F	Conductivity (S/m) ^F	ConvF X	ConvF Y	ConvF Z	Alpha ^G	Depth ^G (mm)	Unct. (k=2)
750	41.9	0.89	6.73	6.73	6.73	0.80	1.13	± 12.0 %
835	41.5	0.90	6.50	6.50	6.50	0.52	1.40	± 12.0 %
900	41.5	0.97	6.40	6.40	6.40	0.77	1.16	± 12.0 %
1750	40.1	1.37	5.28	5.28	5.28	0.41	1.60	± 12.0 %
1900	40.0	1.40	5.12	5.12	5.12	0.43	1.62	± 12.0 %
2000	40.0	1.40	5.10	5.10	5.10	0.41	1.60	± 12.0 %
2450	39.2	1.80	4.52	4.52	4.52	0.71	1.28	± 12.0 %
2600	39.0	1.96	4.37	4.37	4.37	0.80	1.21	± 12.0 %

^C Frequency validity above 300 MHz of ± 100 MHz only applies for DASY v4.4 and higher (see Page 2), else it is restricted to ± 50 MHz. The uncertainty is the RSS of the ConvF uncertainty at calibration frequency and the uncertainty for the indicated frequency band. Frequency validity below 300 MHz is ± 10, 25, 40, 50 and 70 MHz for ConvF assessments at 30, 64, 128, 150 and 220 MHz respectively. Above 5 GHz frequency validity can be extended to ± 110 MHz.

^F At frequencies below 3 GHz, the validity of tissue parameters (ϵ and σ) can be relaxed to ± 10% if liquid compensation formula is applied to measured SAR values. At frequencies above 3 GHz, the validity of tissue parameters (ϵ and σ) is restricted to ± 5%. The uncertainty is the RSS of the ConvF uncertainty for indicated target tissue parameters.

^G Alpha/Depth are determined during calibration. SPEAG warrants that the remaining deviation due to the boundary effect after compensation is always less than ± 1% for frequencies below 3 GHz and below ± 2% for frequencies between 3-6 GHz at any distance larger than half the probe tip diameter from the boundary.