

FCC Test Report

Product Name : ASUS SRT-AC1900 Wireless Smart Router

Trade Name : ASUS

Model No. : SRT-AC1900

FCC ID. : MSQ-SRTAC1900

Applicant : ASUSTeK COMPUTER INC.

Address : 4F, No. 150, Li-Te Rd., Peitou, Taipei, Taiwan

Date of Receipt : Jun. 11, 2015

Issued Date : Aug. 20, 2015

Report No. : 1560358R-RFUSP28V00-A

Report Version : V1.0



The test results relate only to the samples tested.

The test report shall not be reproduced except in full without the written approval of QuieTek Corporation.

Test Report Certification

Issued Date : Aug. 20, 2015

Report No. : 1560358R-RFUSP28V00-A



Product Name : ASUS SRT-AC1900 Wireless Smart Router
 Applicant : ASUSTeK COMPUTER INC.
 Address : 4F, No. 150, Li-Te Rd., Peitou, Taipei, Taiwan
 Manufacturer : MAINTEK Computer(Suzhou) Co., Ltd.
 Model No. : SRT-AC1900
 FCC ID. : MSQ-SRTAC1900
 EUT Test Voltage : AC 100-240V, 50-60Hz
 Testing Voltage : AC 120V/60Hz
 Trade Name : ASUS
 Applicable Standard : FCC CFR Title 47 Part 15 Subpart C Section 15.247: 2014
 ANSI C63.10:2013
 Test Lab : QuieTek Hsin Chu Laboratory
 Test Result : Complied

The test results relate only to the samples tested.

The test report shall not be reproduced except in full without the written approval of QuieTek Corporation.

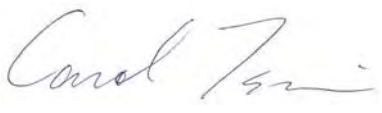
Documented By : 

 (Carol Tsai / Senior Engineering Adm. Specialist)

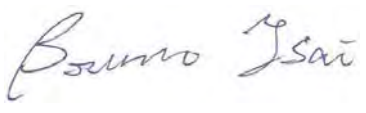
Tested By : 

 (Bruno Tsai / Engineer)

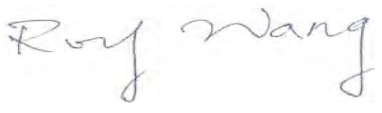
Approved By : 

 (Roy Wang / Director)

Revision History

Report No.	Version	Description	Issued Date
1560358R-RFUSP28V00-A	Rev. 1.0	Initial issue of report	Aug. 20, 2015

Laboratory Information

We, **Quietek Corporation**, are an independent RF consultancy that was established the whole facility in our laboratories. The test facility has been accredited/accepted (audited or listed) by the following related bodies in compliance with ISO 17025 specified testing scopes:

Taiwan R.O.C.	:	TAF, Accreditation Number: 3024
USA	:	FCC, Registration Number: 365520
Canada	:	IC, Submission No: 181665 / IC Registration Number: 4075C-4

The related certificate for our laboratories about the test site and management system can be downloaded from Quietek Corporation's Web Site:<http://www.quietek.com/english/about/certificates.aspx?bval=5>

The address and introduction of Quietek Corporation's laboratories can be founded in our Web site : http://www.quietek.com/index_en.aspx

If you have any comments, Please don't hesitate to contact us. Our contact information is as below:

HsinChu Testing Laboratory:

No.75-2, 3rd Lin, Wangye Keng, Yonghxing Tsuen, Qionglin Shiang, Hsinchu County 307, Taiwan, R.O.C.

TEL:+886-3-592-8858 / FAX:+886-3-592-8859

E-Mail : service@quietek.com

LinKou Testing Laboratory:

No.5-22, Ruishukeng, Linkou Dist., New Taipei City 24451, Taiwan, R.O.C.

TEL : 886-2-8601-3788 / FAX : 886-2-8601-3789

E-Mail : service@quietek.com

TABLE OF CONTENTS

Description	Page
1. General Information.....	7
1.1. EUT Description	7
1.2. Test Mode	12
1.3. Tested System Details	13
1.4. Configuration of tested System	13
1.5. EUT Exercise Software	14
1.6. Test Facility.....	15
2. Conducted Emission	16
2.1. Test Equipment.....	16
2.2. Test Setup	16
2.3. Limits	17
2.4. Test Procedure	17
2.5. Test Specification.....	17
2.6. Uncertainty	17
2.7. Test Result.....	18
3. Peak Power Output	24
3.1. Test Equipment.....	24
3.2. Test Setup	24
3.3. Test procedures.....	24
3.4. Limits	24
3.5. Test Specification.....	24
3.6. Uncertainty	24
3.7. Test Result.....	25
4. Radiated Emission	41
4.1. Test Equipment.....	41
4.2. Test Setup	41
4.3. Limits	42
4.4. Test Procedure	42
4.5. Test Specification.....	42
4.6. Uncertainty	42
4.7. Test Result.....	43
5. RF antenna conducted test	91
5.1. Test Equipment.....	91
5.2. Test Setup	91
5.3. Limits	92
5.4. Test Procedure	92
5.5. Test Specification.....	92
5.6. Uncertainty	92
5.7. Test Result.....	93

6.	Radiated Emission Band Edge.....	113
6.1.	Test Equipment.....	113
6.2.	Test Setup	113
6.3.	Limits	114
6.4.	Test Procedure	114
6.5.	Test Specification.....	114
6.6.	Uncertainty	114
6.7.	Test Result.....	115
7.	DTS Occupied Bandwidth	163
7.1.	Test Equipment.....	163
7.2.	Test Setup	163
7.3.	Test Procedures	163
7.4.	Limits	163
7.5.	Test Specification.....	163
7.6.	Uncertainty	163
7.7.	Test Result.....	164
8.	Occupied Bandwidth	176
8.1.	Test Equipment.....	176
8.2.	Test Setup	176
8.3.	Test Procedures	176
8.4.	Limits	176
8.5.	Test Specification.....	176
8.6.	Uncertainty	176
8.7.	Test Result.....	177
9.	Power Density	189
9.1.	Test Equipment.....	189
9.2.	Test Setup	189
9.3.	Limits	189
9.4.	Test Procedures	189
9.5.	Test Specification.....	189
9.6.	Uncertainty	189
9.7.	Test Result.....	190
Attachment 1	202
	ALL Channel List	202
Attachment 2	204
	Test Setup Photograph.....	204
Attachment 3	211
	EUT External Photograph.....	211
Attachment 4	217
	EUT Internal Photograph.....	217

1. General Information

1.1. EUT Description

Product Name	ASUS SRT-AC1900 Wireless Smart Router
Product Type	WLAN (1TX, 1RX)
Trade Name	ASUS
Model No.	SRT-AC1900
Frequency Range/Channel Number -IEEE 802.11b/g & IEEE 802.11n (20MHz)	2412~2462MHz / 11 Channels
Frequency Range/Channel Number IEEE 802.11n (40MHz)	2422~2452MHz / 7 Channels
Type of Modulation (IEEE 802.11b)	Direct Sequence Spread Spectrum (DSSS)
Type of Modulation (IEEE 802.11g/n)	Orthogonal Frequency Division Multiplexing (OFDM)
Data Speed (IEEE 802.11b)	1Mbps, 2Mbps, 5.5Mbps, 11Mbps
Data Speed (IEEE 802.11g)	6Mbps,9Mbps,12Mbps,18Mbps,24Mbps,36Mbps,48Mbps,54Mbps
Data Speed (IEEE 802.11n)	Support a subset of the combination of GI, MCS 0~MCS 7 and bandwidth defined in 802.11n
Antenna Type	PIFA
Antenna Gain	5.10dBi

Antenna Gain:

	V0	V1	V2	H0	H1	H2	AUX	ZB	BT
2.4G	3.82	3.90	2.36	2.90	2.26	3.27	5.10	3.56	3.61
5G-band1	4.58	4.87	4.29	5.04	5.37	4.68	4.40	X	X
5G-band2	4.65	5.10	4.59	5.04	5.35	4.28	4.40	X	X
5G-band3	4.93	4.78	5.67	5.00	4.84	4.96	2.92	X	X
5G-band4	4.23	4.70	5.07	5.55	4.55	5.11	3.95	X	X

Antenna array Gain:

	V0 V1 V2	V0 V1 H2	V0 H1 V2	V0 H1 H2	H0 V1 V2	H0 V1 H2	H0 H1 V2	H0,H1,H2
2.4G	6.35	6.10	5.71	6.05	5.50	5.18	4.76	6.25
5G-band1	8.33	7.02	7.58	7.72	7.93	6.31	7.04	9.11
5G-band2	8.33	7.02	7.58	7.74	7.93	6.19	7.06	9.16
5G-band3	8.91	7.58	7.79	7.88	7.99	7.04	7.37	9.15
5G-band4	8.95	7.51	7.80	8.41	7.36	7.17	7.48	9.34

Accessories Information	
LAN Cable	Non-Shielded, 1.8m, 2 PCS
Power Adatper	PIE., AD891M21 I/P: 100-240V~ 50/60Hz 0.8A O/P : 19V== 1.75A Cable Out: Non-Shielded, 1.8m
Power Adatper	PIE., AD890326 I/P: 100-240V~ 50/60Hz 0.8A O/P : 19V== 1.75A Cable Out: Non-Shielded, 1.8m
Power Adatper	Delta, ADP-33AW I/P: 100-240V~1A 50-60Hz O/P : 19V== 1.75A Cable Out: Non-Shielded, 1.8m

ANT-TX / RX & Bandwidth

ANT-TX / RX	TX		RX	
	20MHz	40MHz	20MHz	40MHz
IEEE802.11b	✓		✓	
IEEE802.11g	✓		✓	
IEEE802.11n	✓	✓	✓	✓

Wifi: 3TX / 3RX(H/V Antenna); Wifi: 1TX / 1RX(AUX Antenna);

BT 2.0: 1TX/1RX; BT4.0: 1TX/1RX; Zigbee: 1TX/1RX



IEEE 802.11n

MCS Index	Modulation	R	N _{BPSCS}	N _{CBPS}		N _{DBPS}		Data Rate(Mb/s)			
				20MHz	40MHz	20MHz	40MHz	800ns GI		400ns GI	
								20MHz	40MHz	20MHz	40MHz
0	BPSK	1/2	1	52	108	26	54	6.5	13.5	7.2	15.0
1	QPSK	1/2	2	104	216	52	108	13.0	27.0	14.4	30.0
2	QPSK	3/4	2	104	216	78	162	19.5	40.5	21.7	45.0
3	16-QAM	1/2	4	208	432	104	216	26.0	54.0	28.9	60.0
4	16-QAM	3/4	4	208	432	156	324	39.0	81.0	43.3	90.0
5	64-QAM	2/3	6	312	648	208	432	52.0	108.0	57.8	120.0
6	64-QAM	3/4	6	312	648	234	486	58.5	121.5	65.0	135.0
7	64-QAM	5/6	6	312	648	260	540	65.0	135.0	72.2	150.0

Note 1: Support of 400ns GI is optional on transmit and receive.

Table 1 – MCS parameters for TX Antenna number = 1

Symbol	Explanation
R	Code rate
N _{BPSCS}	Number of coded bits per single carrier
N _{CBPS}	Number of coded bits per symbol
N _{DBPS}	Number of data bits per symbol
GI	guard interval

IEEE 802.11b/g & IEEE 802.11n (20MHz)

Working Frequency of Each Channel							
Channel	Frequency	Channel	Frequency	Channel	Frequency	Channel	Frequency
001	2412 MHz	002	2417 MHz	003	2422 MHz	004	2427 MHz
005	2432 MHz	006	2437 MHz	007	2442 MHz	008	2447 MHz
009	2452 MHz	010	2457 MHz	011	2462 MHz		

IEEE 802.11n (40MHz)

Working Frequency of Each Channel							
Channel	Frequency	Channel	Frequency	Channel	Frequency	Channel	Frequency
003	2422 MHz	004	2427 MHz	005	2432 MHz	006	2437 MHz
007	2442 MHz	008	2447 MHz	009	2452 MHz		

Note:

1. This device is an ASUS SRT-AC1900 Wireless Smart Router including 2.4G & 5GHz Wifi (H/V Antenna): b/g/a/n/ac (3x3) 、 2.4G& 5GHz Wifi (AUX Antenna): b/g/a/n/ac (1x1) 、 BT 2.0 、 BT4.0 and Zigbee transmitting and receiving function.
2. These test results on a sample of the device are for the purpose of demonstrating Compliance with Part 15 Subpart C Paragraph 15.247.
3. Regards to the frequency band operation; the lowest 、 middle and highest frequency of channel were selected to perform the test, and then shown on this report.
4. The 2.4G is performed according to the DTS Test Procedures old Rules.
5. This device has USB and Ethernet ports, which can be connected to computer. It is a Class B personal computer and peripheral. Its test report number is 1560358R-RFUSP01V00 under part 15B with Declaration of Conformity letter.
6. The function of the 2.4GHz & 5GHz transmitting is measured. The test report of the number is 1560358R-RFUSP28V00 & 1560358R-RFUSP59V00 & 1560358R-RFUSP59V00-A.
7. The function of the Zigbee transmitting is measured the test report of the number is 1560358R-RFUSP24V00
8. The function of the BT2.0 and BT4.0 transmitting are measured and makes a test report of the report number: 1560358R-RFUSP01V00-A and 1560358R-RFUSP01V00-B.

1.2. Test Mode

Quietek has verified the construction and function in typical operation. The preliminary tests were performed in different data rate, and to find the worst condition, which was shown in this test report. The following table is the final test mode.

TX	Mode 1: Tx- AUX Antenna (AD891M21) Mode 2: Tx- AUX Antenna (AD890326) Mode 3: Tx- AUX Antenna (ADP-33AW)
----	--

Test Items	Modulation	Channel	Antenna	Result
Conducted Emission	11n(40MHz)	6	0	Complies
Peak Power Output	11b/g	1/ 6/ 11	0	Complies
	11n(20MHz)	1/ 6/ 11	0	Complies
	11n(40MHz)	3/ 6/ 9	0	Complies
Radiated Emission	11b/g	1/ 6/ 11	0	Complies
	11n(20MHz)	1/ 6/ 11	0	Complies
	11n(40MHz)	3/ 6/ 9	0	Complies
RF antenna conducted test	11b/g	1/ 6/ 11	0	Complies
	11n(20MHz)	1/ 6/ 11	0	Complies
	11n(40MHz)	3/ 6/ 9	0	Complies
Radiated Emission Band Edge	11b/g	1/ 11	0	Complies
	11n(20MHz)	1/ 11	0	Complies
	11n(40MHz)	3/ 9	0	Complies
DTS Occupied Bandwidth	11b/g	1/ 6/ 11	0	Complies
	11n(20MHz)	1/ 6/ 11	0	Complies
	11n(40MHz)	3/ 6/ 9	0	Complies
Occupied Bandwidth	11b/g	1/ 6/ 11	0	Complies
	11n(20MHz)	1/ 6/ 11	0	Complies
	11n(40MHz)	3/ 6/ 9	0	Complies
Power Density	11b/g	1/ 6/ 11	0	Complies
	11n(20MHz)	1/ 6/ 11	0	Complies
	11n(40MHz)	3/ 6/ 9	0	Complies

1.3. Tested System Details

The types for all equipments, plus descriptions of all cables used in the tested system (including inserted cards) are:

Product	Manufacturer	Model No.	Serial No.	FCC ID	Power Cord
1 Notebook PC	DELL	Vostro3400	7F808N1	DoC	Non-Shielded, 1.8m
2 USB 2.0 Flash Memory	Apacer	AH223	N/A	DoC	--

1.4. Configuration of tested System

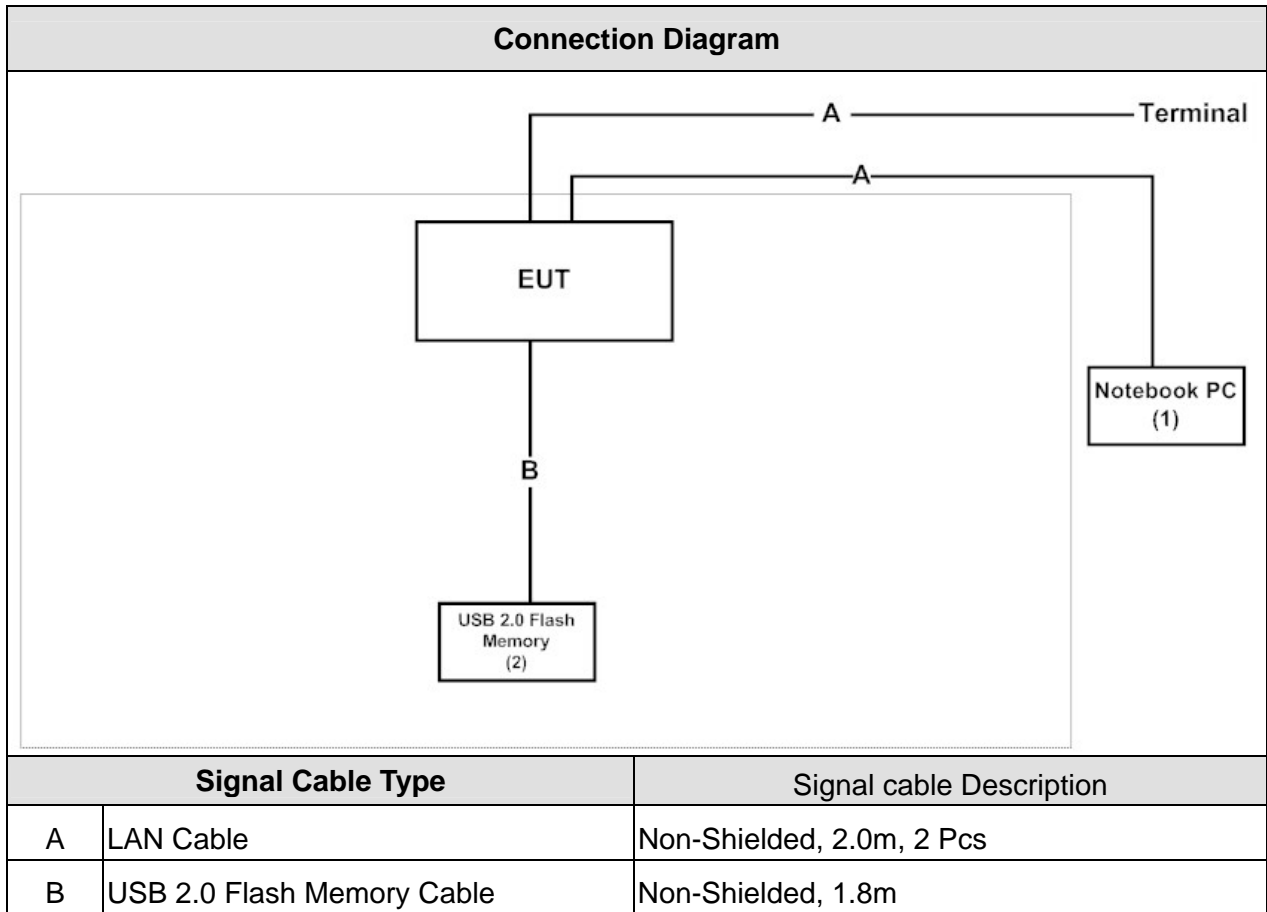

1.5. EUT Exercise Software

1	Setup the EUT as shown in Section 1.4.
2	Execute the telnet command on the EUT.
3	Configure the test mode, the test channel, and the data rate.
4	Verify that the EUT works properly.

1.6. Test Facility

Ambient conditions in the laboratory:

Items	Test Item	Required (IEC 68-1)	Actual
Temperature (°C)	FCC PART 15 C 15.207 Conducted Emission	15 - 35	20
Humidity (%RH)		25 - 75	50
Barometric pressure (mbar)		860 - 1060	950-1000
Temperature (°C)	FCC PART 15 C 15.247 Peak Power Output	15 - 35	25
Humidity (%RH)		25 - 75	45
Barometric pressure (mbar)		860 - 1060	950-1000
Temperature (°C)	FCC PART 15 C 15.247 Radiated Emission	15 - 35	20
Humidity (%RH)		25 - 75	50
Barometric pressure (mbar)		860 - 1060	950-1000
Temperature (°C)	FCC PART 15 C 15.247 RF antenna conducted test	15 - 35	25
Humidity (%RH)		25 - 75	45
Barometric pressure (mbar)		860 - 1060	950-1000
Temperature (°C)	FCC PART 15 C 15.247 Band Edge	15 - 35	20
Humidity (%RH)		25 - 75	50
Barometric pressure (mbar)		860 - 1060	950-1000
Temperature (°C)	FCC PART 15 C 15.247 Occupied Bandwidth	15 - 35	25
Humidity (%RH)		25 - 75	45
Barometric pressure (mbar)		860 - 1060	950-1000
Temperature (°C)	FCC PART 15 C 15.247 Power Density	15 - 35	25
Humidity (%RH)		25 - 75	45
Barometric pressure (mbar)		860 - 1060	950-1000

2. Conducted Emission

2.1. Test Equipment

The following test equipments are used during the test:

Conducted Emission / SR3

Instrument	Manufacturer	Model No.	Serial No	Next Cal. Date
Artificial Mains Network	R&S	ENV4200	848411/010	2016/01/25
LISN	R&S	ENV216	100092	2015/08/24
Test Receiver	R&S	ESCS 30	825442/014	2016/07/13

Note: 1. All equipments that need to calibrate are with calibration period of 1 year.

2.2. Test Setup

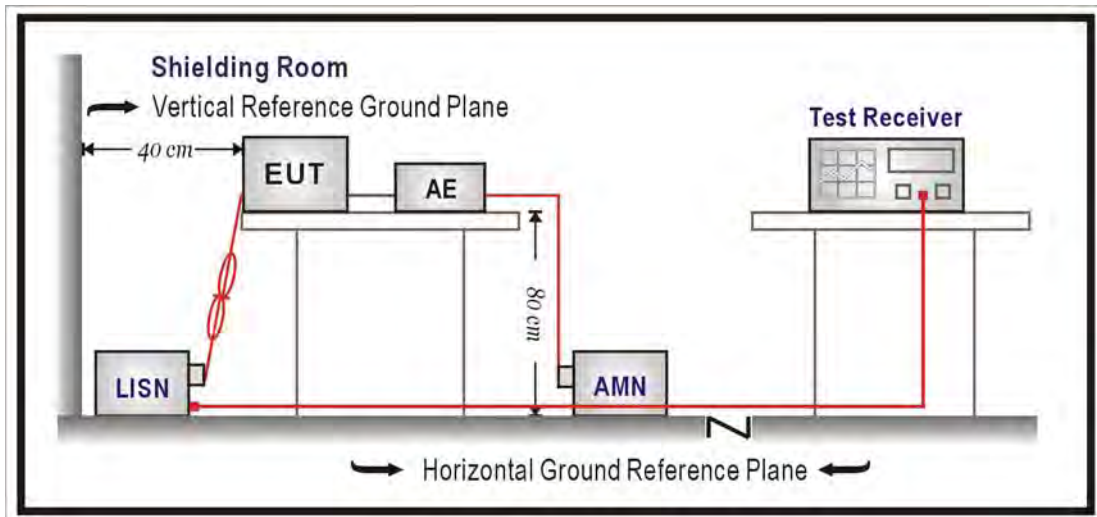

2.3. Limits

FCC Part 15 Subpart C Paragraph 15.207 Limits (dBuV)		
Frequency MHz	QP	AV
0.15 - 0.50	66-56	56-46
0.50 - 5.0	56	46
5.0 - 30	60	50

Remarks: In the above table, the tighter limit applies at the band edges.

2.4. Test Procedure

The EUT was setup according to ANSI C63.10:2013 and tested according to DTS test procedure of KDB558074 for compliance to FCC 47CFR 15.247 requirements.

The EUT was placed on a platform of nominal size, 1 m by 1.5 m, raised 80 cm above the conducting ground plane. The vertical conducting plane was located 40 cm to the rear of the EUT. All other surfaces of EUT were at least 80 cm from any other grounded conducting surface. The EUT and simulators are connected to the main power through a line impedance stabilization network (LISN). The LISN provides a 50 ohm /50uH coupling impedance for the measuring equipment. The peripheral devices are also connected to the main power through a LISN. (Please refer to the block diagram of the test setup and photographs.)

Each current-carrying conductor of the EUT power cord, except the ground (safety) conductor, was individually connected through a LISN to the input power source.

The excess length of the power cord between the EUT and the LISN receptacle were folded back and forth at the center of the lead to form a bundle not exceeding 40 cm in length.

Conducted emissions were investigated over the frequency range from 0.15MHz to 30MHz using a receiver bandwidth of 9 kHz.

2.5. Test Specification

According to FCC Part 15 Subpart C Paragraph 15.207: 2014

2.6. Uncertainty

The measurement uncertainty is defined as ± 2.26 dB.

2.7. Test Result

Site : SR3	Time : 2015/08/05 - 16:14
Limit : CISPR_B_00M_QP	Margin : 10
Probe : SR3_LISN(16A)-4_0811 - Line1	Power : AC 120V/60Hz
EUT : ASUS SRT-AC1900 Wireless Smart Router	Note : Mode 1: Tx- AUX Antenna (AD891M21) 802.11n40_2437MHz

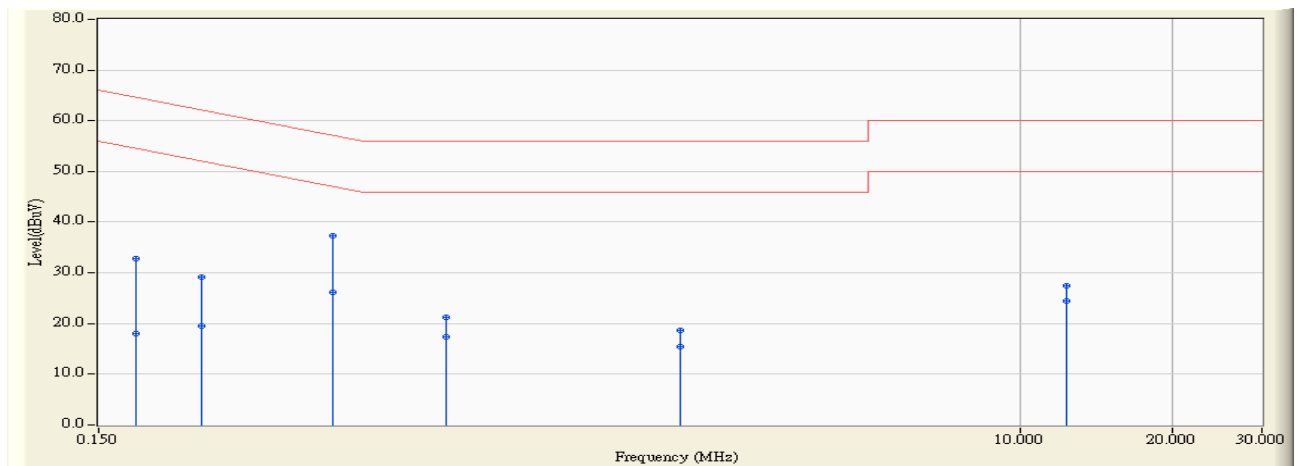

	Frequency (MHz)	Correct Factor (dB)	Reading Level (dBμV)	Measure Level (dBμV)	Margin (dB)	Limit (dBμV)	Detector Type
1	0.177	9.668	23.060	32.728	-31.881	64.609	QUASPEAK
2	0.177	9.668	8.300	17.968	-36.641	54.609	AVERAGE
3	0.240	9.702	19.500	29.202	-32.900	62.102	QUASPEAK
4	0.240	9.702	9.760	19.462	-32.640	52.102	AVERAGE
5	* 0.435	9.805	27.480	37.285	-19.869	57.154	QUASPEAK
6	0.435	9.805	16.430	26.235	-20.919	47.154	AVERAGE
7	0.732	9.896	11.260	21.156	-34.844	56.000	QUASPEAK
8	0.732	9.896	7.430	17.326	-28.674	46.000	AVERAGE
9	2.123	9.951	8.640	18.591	-37.409	56.000	QUASPEAK
10	2.123	9.951	5.400	15.351	-30.649	46.000	AVERAGE
11	12.298	10.129	17.300	27.429	-32.571	60.000	QUASPEAK
12	12.298	10.129	14.390	24.519	-25.481	50.000	AVERAGE

Note:

1. All Reading Levels are Quasi-Peak and average value.
2. " * ", means this data is the worst emission level.
3. Measurement Level = Reading Level + Correct Factor.

Site : SR3	Time : 2015/08/05 - 16:11
Limit : CISPR_B_00M_QP	Margin : 10
Probe : SR3_LISN(16A)-4_0811 - Line2	Power : AC 120V/60Hz
EUT : ASUS SRT-AC1900 Wireless Smart Router	Note : Mode 1: Tx- AUX Antenna (AD891M21) 802.11n40_2437MHz

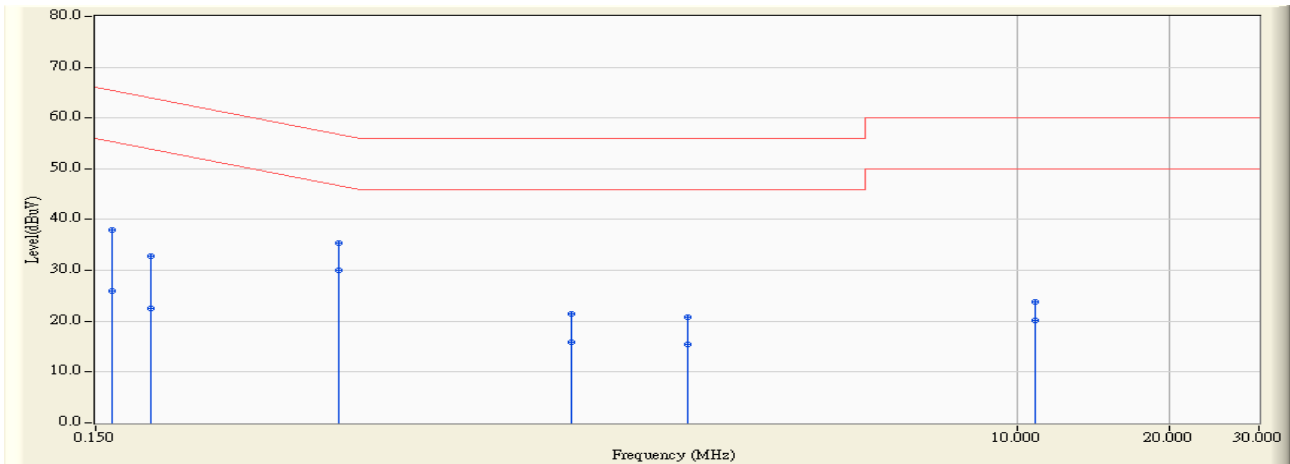

	Frequency (MHz)	Correct Factor (dB)	Reading Level (dBuV)	Measure Level (dBuV)	Margin (dB)	Limit (dBuV)	Detector Type
1	0.162	9.659	28.280	37.939	-27.437	65.375	QUASPEAK
2	0.162	9.659	16.210	25.869	-29.507	55.375	AVERAGE
3	0.193	9.665	23.080	32.744	-31.163	63.908	QUASPEAK
4	0.193	9.665	12.910	22.574	-31.333	53.908	AVERAGE
5	0.455	9.818	25.560	35.378	-21.411	56.789	QUASPEAK
6	*	9.818	20.270	30.088	-16.701	46.789	AVERAGE
7	1.306	9.953	11.480	21.433	-34.567	56.000	QUASPEAK
8	1.306	9.953	6.000	15.953	-30.047	46.000	AVERAGE
9	2.228	9.972	10.920	20.892	-35.108	56.000	QUASPEAK
10	2.228	9.972	5.400	15.372	-30.628	46.000	AVERAGE
11	10.849	10.194	13.620	23.814	-36.186	60.000	QUASPEAK
12	10.849	10.194	10.030	20.224	-29.776	50.000	AVERAGE

Note:

1. All Reading Levels are Quasi-Peak and average value.
2. " * ", means this data is the worst emission level.
3. Measurement Level = Reading Level + Correct Factor.

Site : SR3	Time : 2015/08/07 - 13:24
Limit : CISPR_B_00M_QP	Margin : 10
Probe : SR3_LISN(16A)-4_0811 - Line1	Power : AC 120V/60Hz
EUT : ASUS SRT-AC1900 Wireless Smart Router	Note : Mode 2: Tx- AUX Antenna (AD890326) 802.11n40_2437MHz

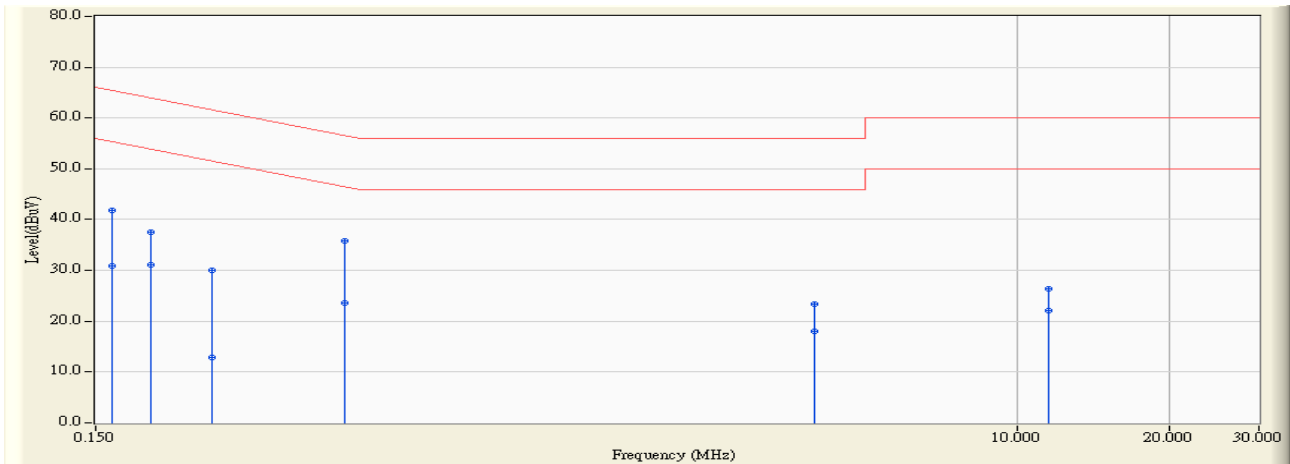

	Frequency (MHz)	Correct Factor (dB)	Reading Level (dBuV)	Measure Level (dBuV)	Margin (dB)	Limit (dBuV)	Detector Type
1	0.162	9.665	32.180	41.845	-23.530	65.375	QUASPEAK
2	0.162	9.665	21.230	30.895	-24.480	55.375	AVERAGE
3	0.193	9.674	27.940	37.613	-26.294	63.908	QUASPEAK
4	0.193	9.674	21.370	31.043	-22.864	53.908	AVERAGE
5	0.255	9.709	20.260	29.969	-31.608	61.577	QUASPEAK
6	0.255	9.709	3.120	12.829	-38.748	51.577	AVERAGE
7	*	9.824	26.060	35.884	-20.694	56.578	QUASPEAK
8	0.466	9.824	13.750	23.574	-23.004	46.578	AVERAGE
9	3.974	10.040	13.280	23.320	-32.680	56.000	QUASPEAK
10	3.974	10.040	7.950	17.990	-28.010	46.000	AVERAGE
11	11.482	10.126	16.320	26.446	-33.554	60.000	QUASPEAK
12	11.482	10.126	12.020	22.146	-27.854	50.000	AVERAGE

Note:

1. All Reading Levels are Quasi-Peak and average value.
2. " * ", means this data is the worst emission level.
3. Measurement Level = Reading Level + Correct Factor.

Site : SR3	Time : 2015/08/07 - 13:27
Limit : CISPR_B_00M_QP	Margin : 10
Probe : SR3_LISN(16A)-4_0811 - Line2	Power : AC 120V/60Hz
EUT : ASUS SRT-AC1900 Wireless Smart Router	Note : Mode 2: Tx- AUX Antenna (AD890326) 802.11n40_2437MHz

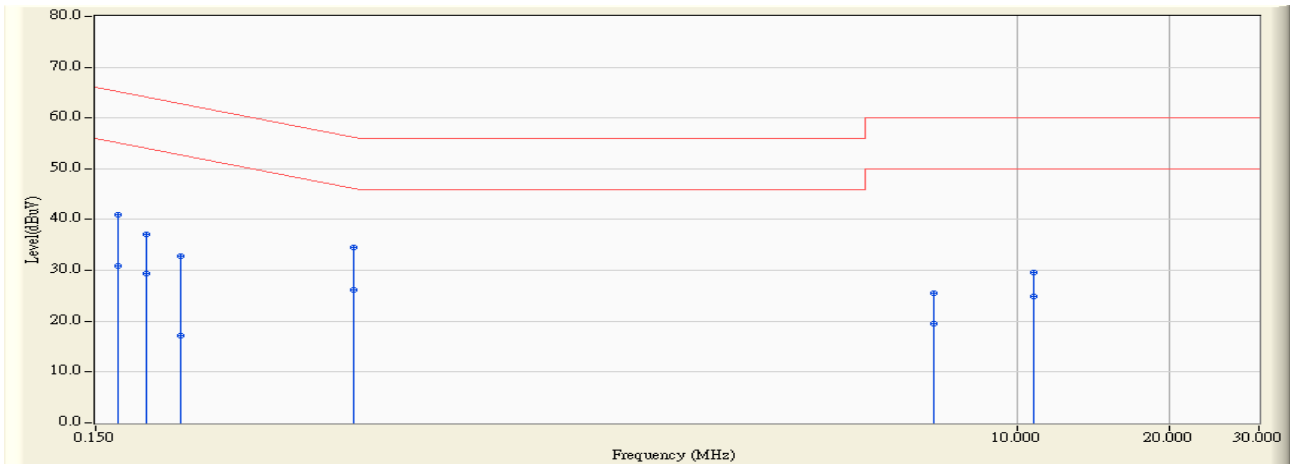

	Frequency (MHz)	Correct Factor (dB)	Reading Level (dBuV)	Measure Level (dBuV)	Margin (dB)	Limit (dBuV)	Detector Type
1	0.166	9.659	31.340	40.999	-24.178	65.177	QUASPEAK
2	0.166	9.659	21.180	30.839	-24.338	55.177	AVERAGE
3	0.189	9.662	27.520	37.182	-26.895	64.078	QUASPEAK
4	0.189	9.662	19.620	29.282	-24.795	54.078	AVERAGE
5	0.220	9.681	23.140	32.821	-29.986	62.807	QUASPEAK
6	0.220	9.681	7.580	17.261	-35.546	52.807	AVERAGE
7	0.486	9.830	24.800	34.630	-21.606	56.237	QUASPEAK
8	* 0.486	9.830	16.320	26.150	-20.086	46.237	AVERAGE
9	6.806	10.127	15.380	25.507	-34.493	60.000	QUASPEAK
10	6.806	10.127	9.390	19.517	-30.483	50.000	AVERAGE
11	10.759	10.192	19.500	29.692	-30.308	60.000	QUASPEAK
12	10.759	10.192	14.600	24.792	-25.208	50.000	AVERAGE

Note:

1. All Reading Levels are Quasi-Peak and average value.
2. " * ", means this data is the worst emission level.
3. Measurement Level = Reading Level + Correct Factor.

Site : SR3	Time : 2015/08/04 - 17:18
Limit : CISPR_B_00M_QP	Margin : 10
Probe : SR3_LISN(16A)-4_0811 - Line1	Power : AC 120V/60Hz
EUT : ASUS SRT-AC1900 Wireless Smart Router	Note : Mode 3: Tx- AUX Antenna (ADP-33AW) 802.11n40_2437MHz

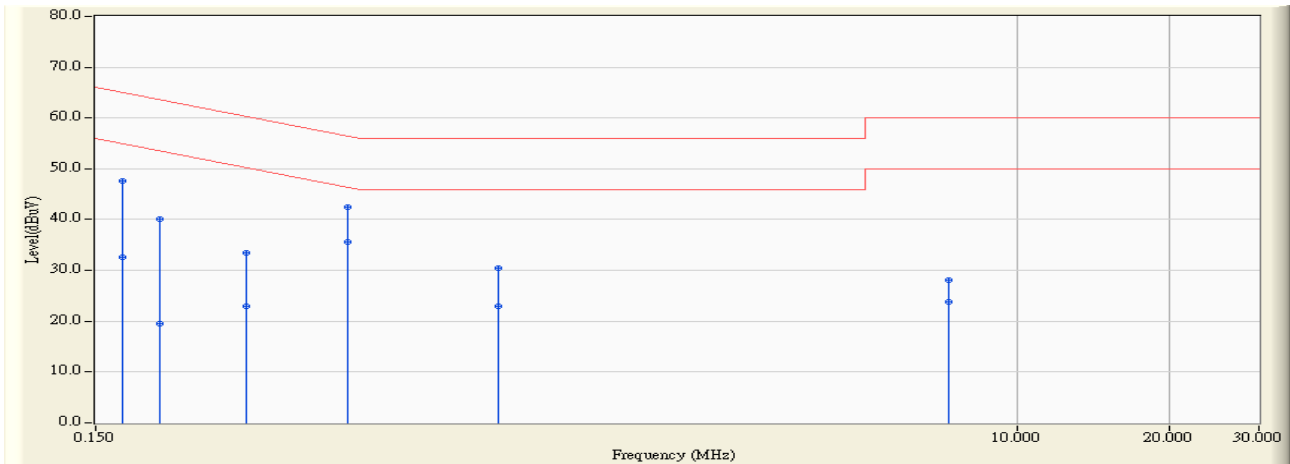

	Frequency (MHz)	Correct Factor (dB)	Reading Level (dBuV)	Measure Level (dBuV)	Margin (dB)	Limit (dBuV)	Detector Type
1	0.170	9.667	37.980	47.647	-17.337	64.983	QUASPEAK
2	0.170	9.667	22.910	32.577	-22.407	54.983	AVERAGE
3	0.201	9.678	30.380	40.058	-23.520	63.578	QUASPEAK
4	0.201	9.678	9.800	19.478	-34.100	53.578	AVERAGE
5	0.298	9.728	23.660	33.388	-26.898	60.286	QUASPEAK
6	0.298	9.728	13.150	22.878	-27.408	50.286	AVERAGE
7	0.474	9.826	32.720	42.546	-13.893	56.440	QUASPEAK
8	* 0.474	9.826	25.790	35.616	-10.823	46.440	AVERAGE
9	0.939	9.939	20.580	30.519	-25.481	56.000	QUASPEAK
10	0.939	9.939	13.000	22.939	-23.061	46.000	AVERAGE
11	7.279	10.097	18.040	28.137	-31.863	60.000	QUASPEAK
12	7.279	10.097	13.750	23.847	-26.153	50.000	AVERAGE

Note:

1. All Reading Levels are Quasi-Peak and average value.
2. " * ", means this data is the worst emission level.
3. Measurement Level = Reading Level + Correct Factor.

Site : SR3	Time : 2015/08/04 - 17:19
Limit : CISPR_B_00M_QP	Margin : 10
Probe : SR3_LISN(16A)-4_0811 - Line2	Power : AC 120V/60Hz
EUT : ASUS SRT-AC1900 Wireless Smart Router	Note : Mode 3: Tx- AUX Antenna (ADP-33AW) 802.11n40_2437MHz

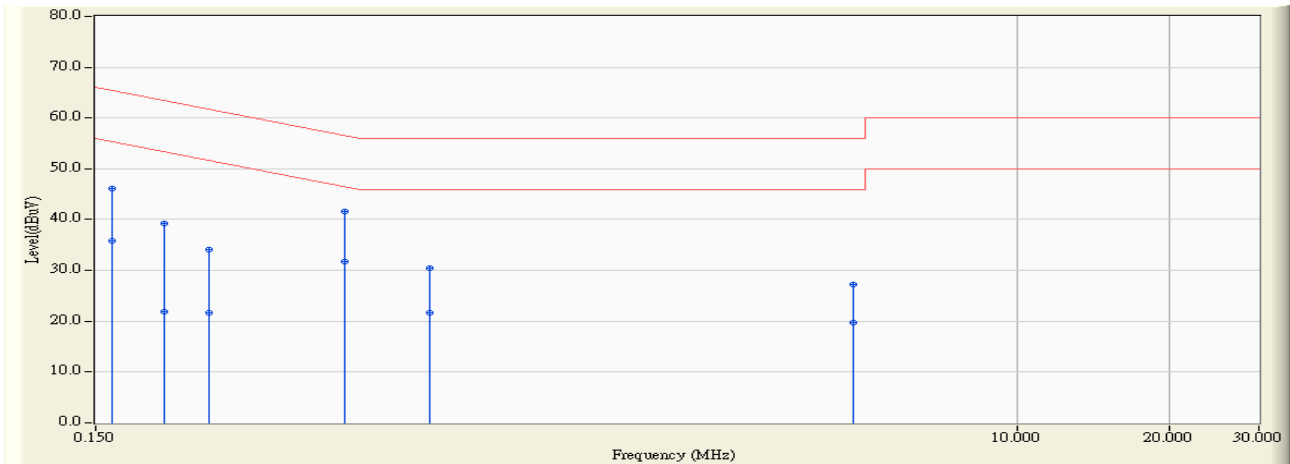

	Frequency (MHz)	Correct Factor (dB)	Reading Level (dBuV)	Measure Level (dBuV)	Margin (dB)	Limit (dBuV)	Detector Type
1	0.162	9.659	36.460	46.119	-19.257	65.375	QUASPEAK
2	0.162	9.659	26.150	35.809	-19.567	55.375	AVERAGE
3	0.205	9.671	29.480	39.152	-24.267	63.418	QUASPEAK
4	0.205	9.671	12.150	21.822	-31.597	53.418	AVERAGE
5	0.252	9.701	24.320	34.021	-27.685	61.705	QUASPEAK
6	0.252	9.701	11.930	21.631	-30.075	51.705	AVERAGE
7	0.466	9.824	31.880	41.704	-14.874	56.578	QUASPEAK
8	* 0.466	9.824	21.950	31.774	-14.804	46.578	AVERAGE
9	0.689	9.882	20.520	30.402	-25.598	56.000	QUASPEAK
10	0.689	9.882	11.800	21.682	-24.318	46.000	AVERAGE
11	4.736	10.082	17.260	27.342	-28.658	56.000	QUASPEAK
12	4.736	10.082	9.630	19.712	-26.288	46.000	AVERAGE

Note:

1. All Reading Levels are Quasi-Peak and average value.
2. " * ", means this data is the worst emission level.
3. Measurement Level = Reading Level + Correct Factor.

3. Peak Power Output

3.1. Test Equipment

The following test equipments are used during the test:

Peak Power Output / SR7

Instrument	Manufacturer	Model No.	Serial No	Next Cal. Date
Spectrum Analyzer	Agilent	N9010A-EXA	US47140172	2016/07/13

Note: 1. All equipments that need to calibrate are with calibration period of 1 year.

3.2. Test Setup

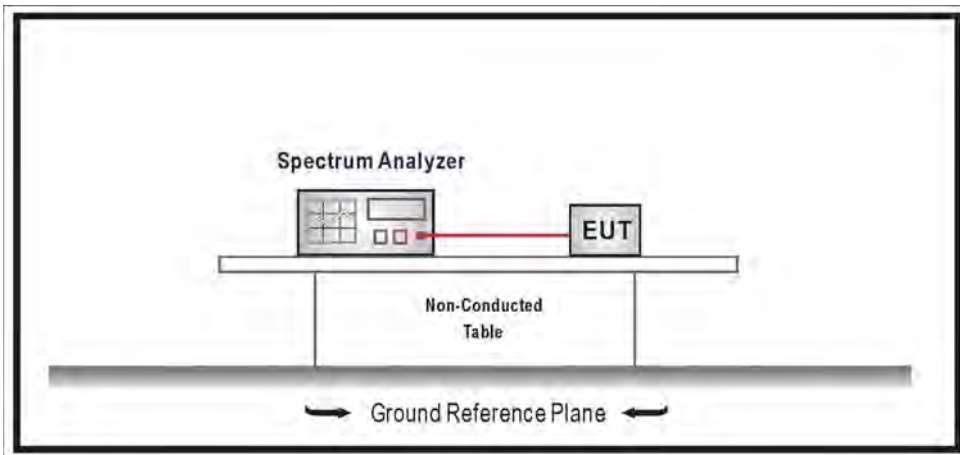

3.3. Test procedures

The EUT was tested according to DTS test procedure section 9.2.2.2 of KDB558074 v03r02 measurement to FCC 47CFR 15.247 requirements.

3.4. Limits

The maximum peak power shall be less 1 Watt.

3.5. Test Specification

According to FCC Part 15 Subpart C Paragraph 15.247: 2014

3.6. Uncertainty

The measurement uncertainty is defined as ± 1.27 dB.

3.7. Test Result

Product	ASUS SRT-AC1900 Wireless Smart Router		
Test Item	Peak Power Output		
Test Mode	Mode 1: Tx- AUX Antenna (AD891M21)		
Date of Test	2015/08/10	Test Site	SR7

IEEE 802.11b (ANT 0)			
Channel No.	Frequency (MHz)	Measure Level (dBm)	Limit (dBm)
1	2412	16.11	≤ 30
6	2437	16.20	≤ 30
11	2462	15.59	≤ 30

The worst emission of data rate is 1Mbps

Peak Power Output (dBm)						
Channel No	Frequency (MHz)	Data Rate (Mbps)				Required Limit (dBm)
		1	2	5.5	11	
1	2412	16.11	--	--	--	≤ 30
6	2437	16.20	16.15	15.11	15.08	≤ 30
11	2462	15.59	--	--	--	≤ 30

Channel 1

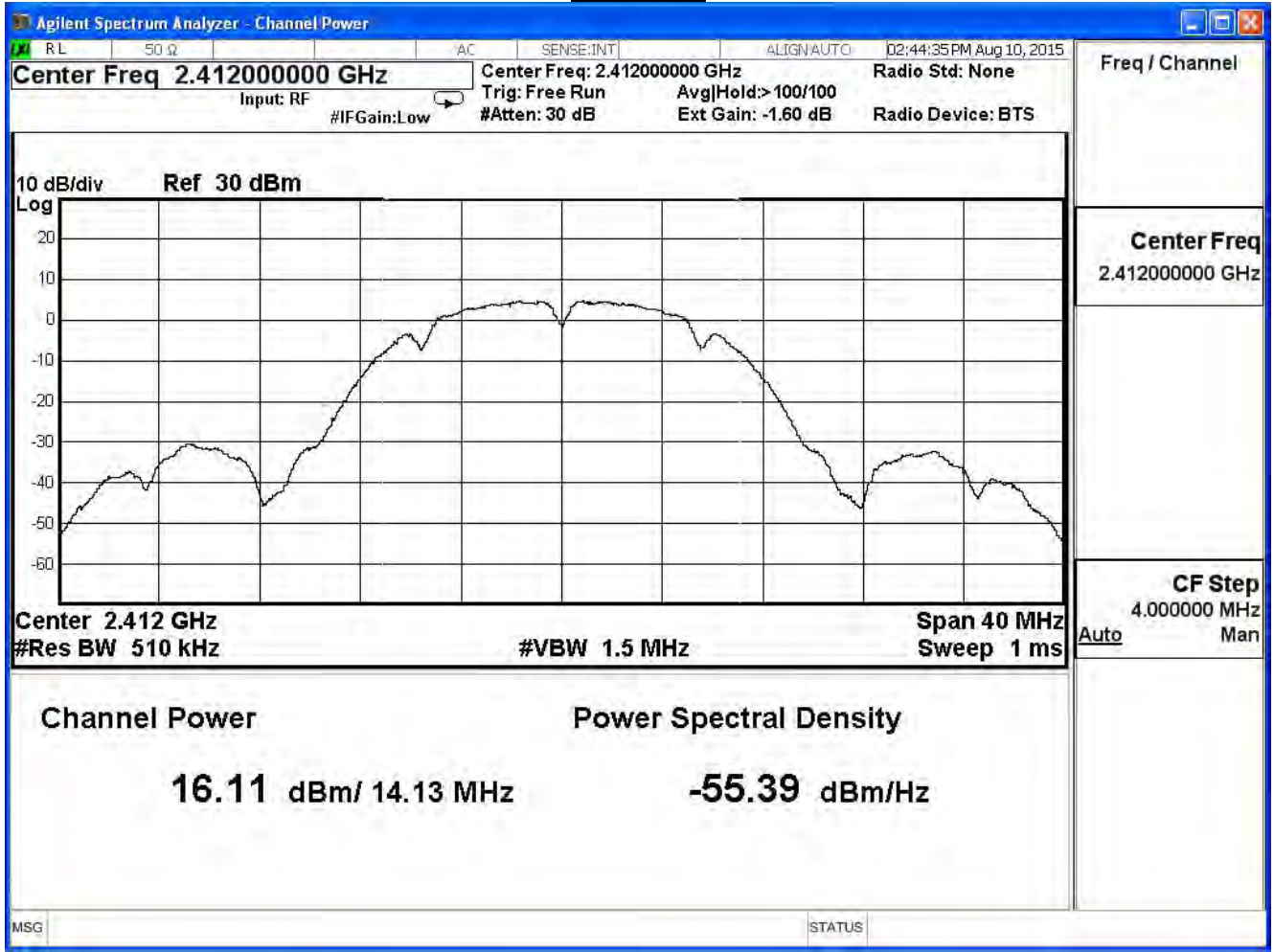

Channel 6

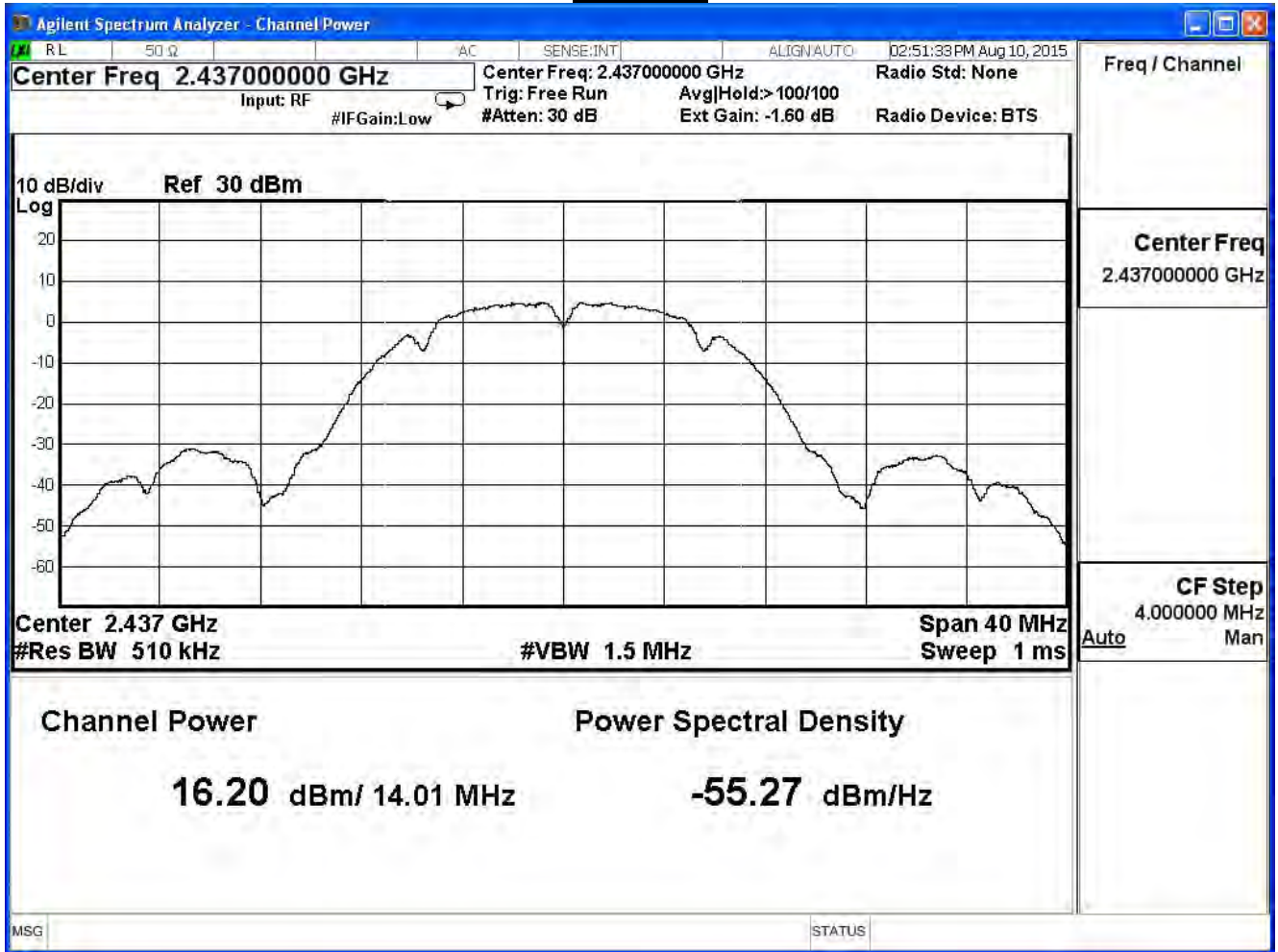

Channel 11

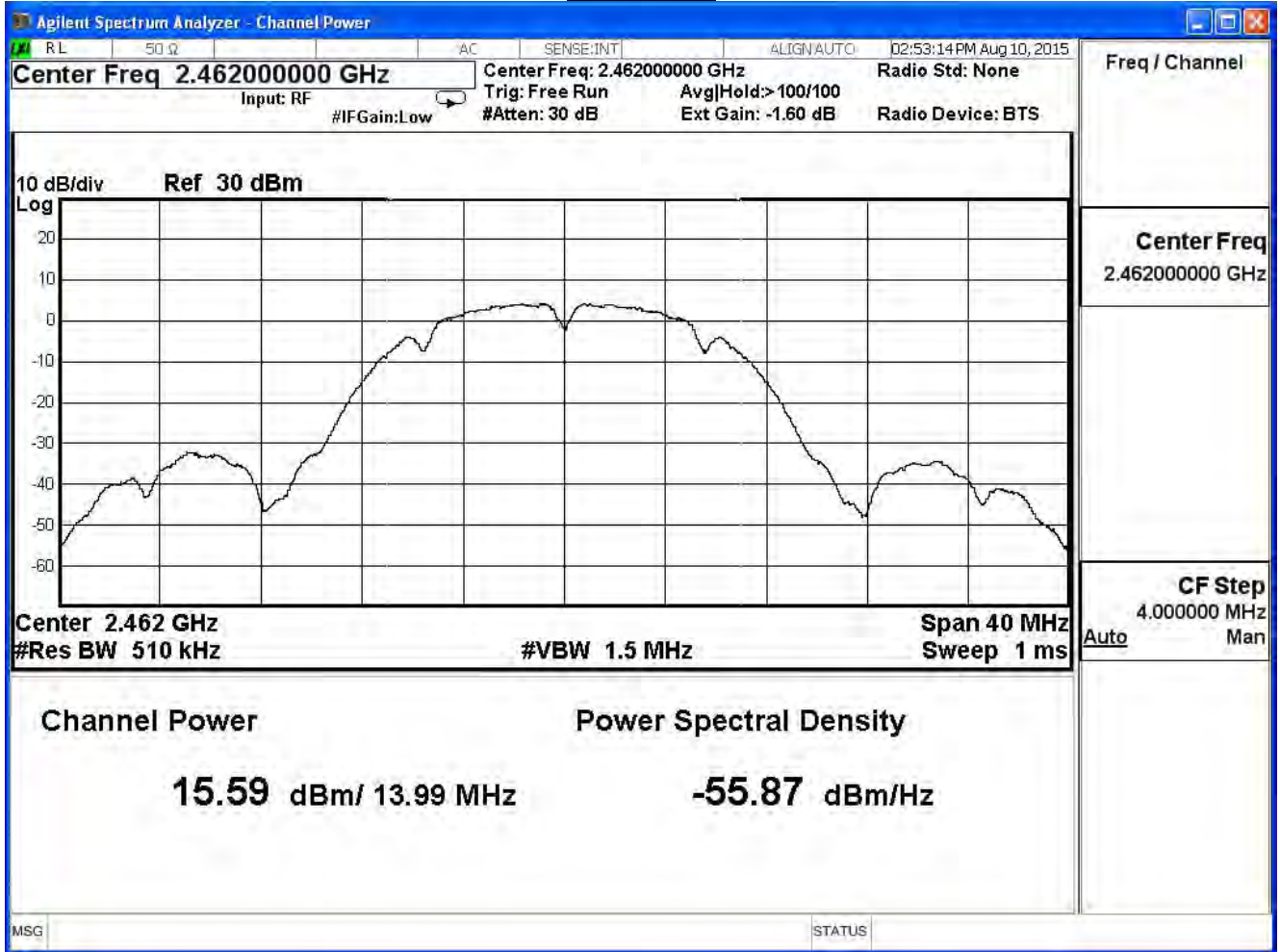

Product	ASUS SRT-AC1900 Wireless Smart Router		
Test Item	Peak Power Output		
Test Mode	Mode 1: Tx- AUX Antenna (AD891M21)		
Date of Test	2015/08/10	Test Site	SR7

IEEE 802.11g (ANT 0)			
Channel No.	Frequency (MHz)	Measure Level (dBm)	Limit (dBm)
1	2412	13.49	≤ 30
6	2437	16.28	≤ 30
11	2462	13.38	≤ 30

The worst emission of data rate is 6Mbps

Peak Power Output (dBm)									
Channel No	Frequency (MHz)	Data Rate (Mbps)							Required Limit (dBm)
		6	12	18	24	36	48	54	
1	2412	13.49	--	--	--	--	--	--	≤ 30
6	2437	16.28	16.24	16.20	16.17	16.13	16.09	15.93	≤ 30
11	2462	13.38	--	--	--	--	--	--	≤ 30

Channel 1

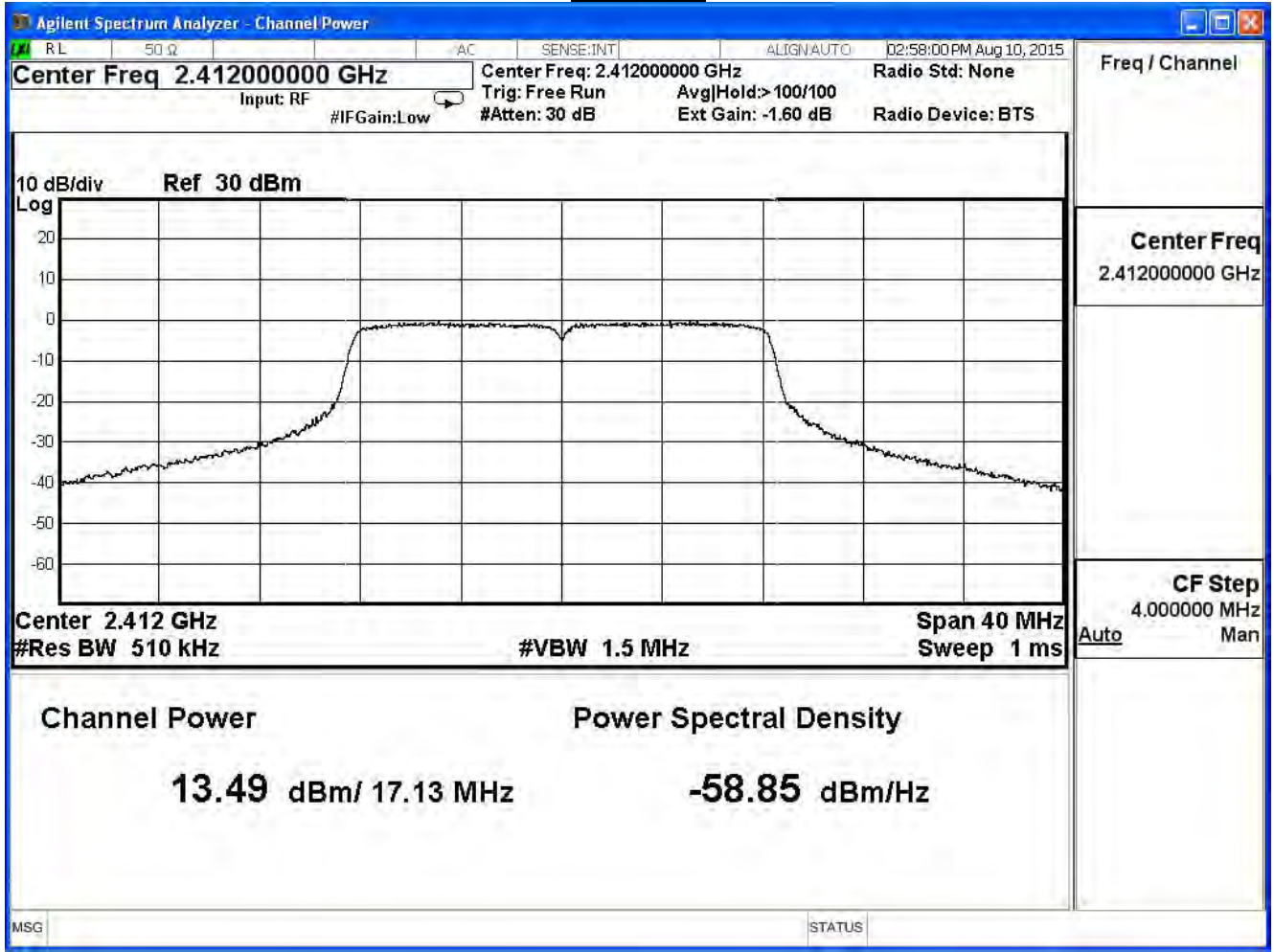

Channel 6

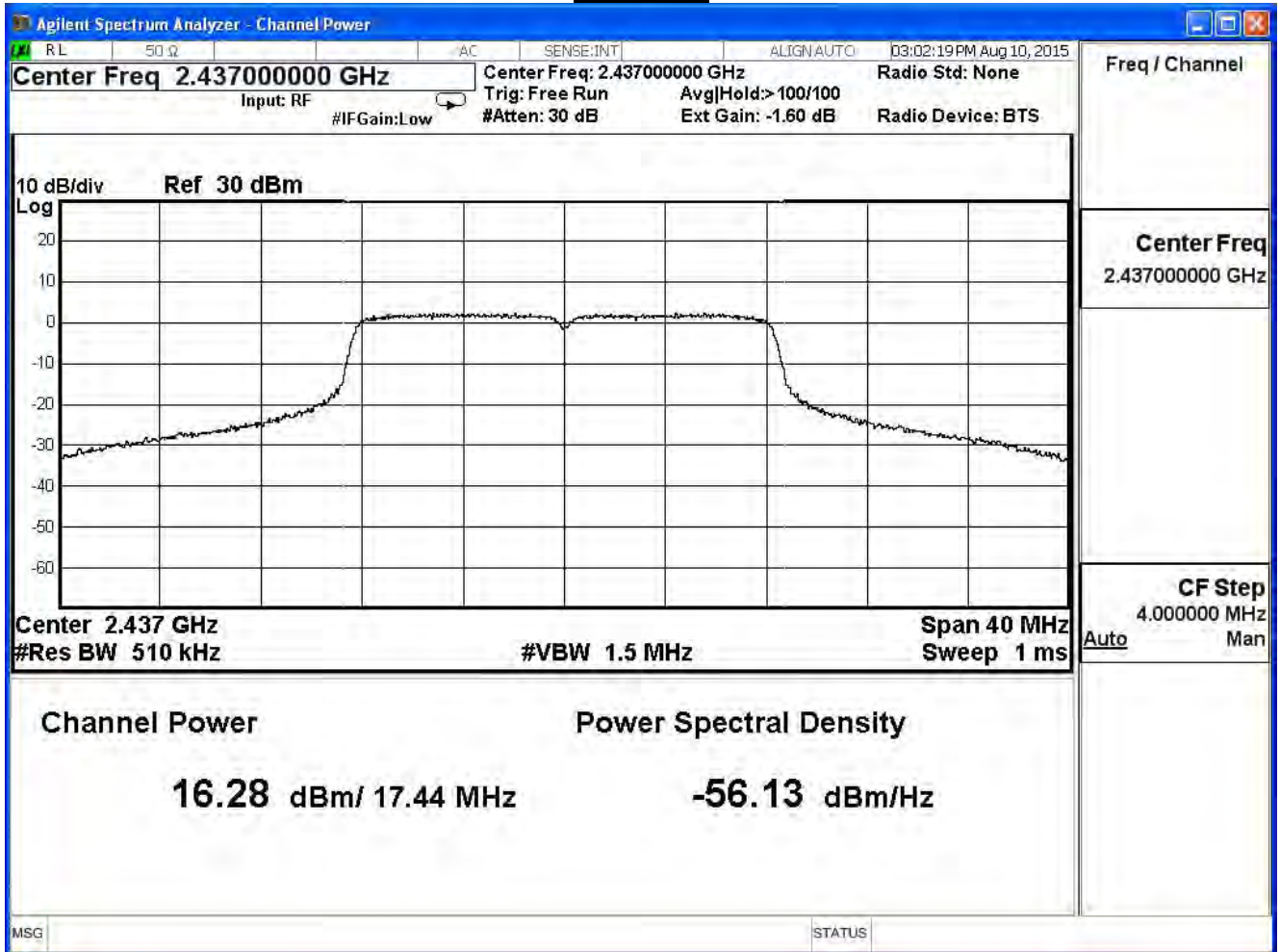

Channel 11

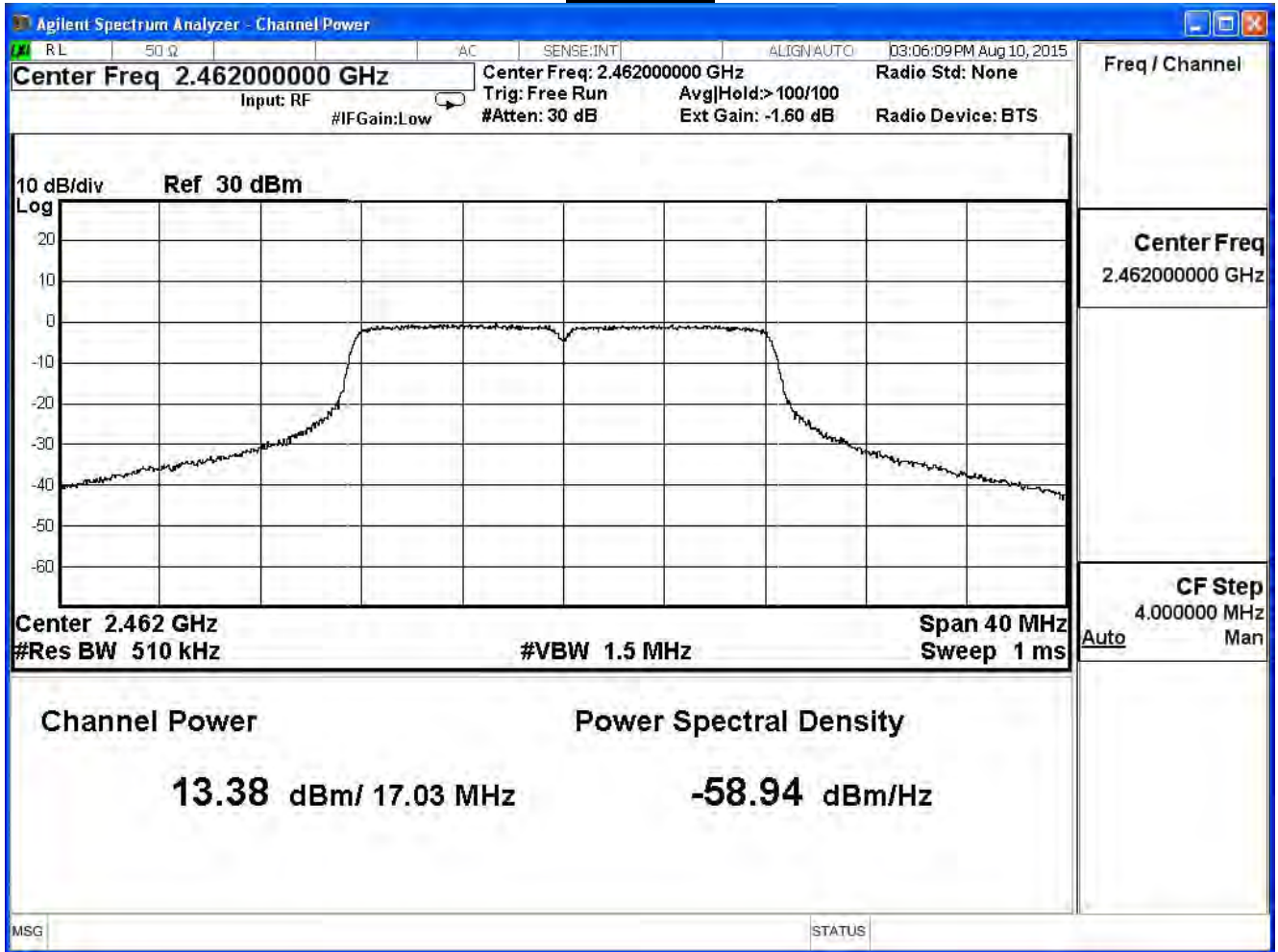

Product	ASUS SRT-AC1900 Wireless Smart Router		
Test Item	Peak Power Output		
Test Mode	Mode 1: Tx- AUX Antenna (AD891M21)		
Date of Test	2015/08/10	Test Site	SR7

IEEE 802.11n (20MHz) (ANT 0)

Channel No.	Frequency (MHz)	Measure Level (dBm)	Limit (dBm)	Result
1	2412	11.85	≤ 30	Pass
6	2437	16.17	≤ 30	Pass
11	2462	12.28	≤ 30	Pass

The worst emission of data rate is 6.5Mbps

Peak Power Output (dBm)										
MCS Index		0	1	2	3	4	5	6	7	Required Limit (dBm)
Channel No	Frequency (MHz)	Data Rate								
		6.5	13	19.5	26	39	52	58.5	65	
1	2412	11.85	--	--	--	--	--	--	--	≤ 30
6	2437	16.17	16.11	16.08	16.01	15.98	15.91	15.88	15.84	≤ 30
11	2462	12.28	--	--	--	--	--	--	--	≤ 30

Channel 1

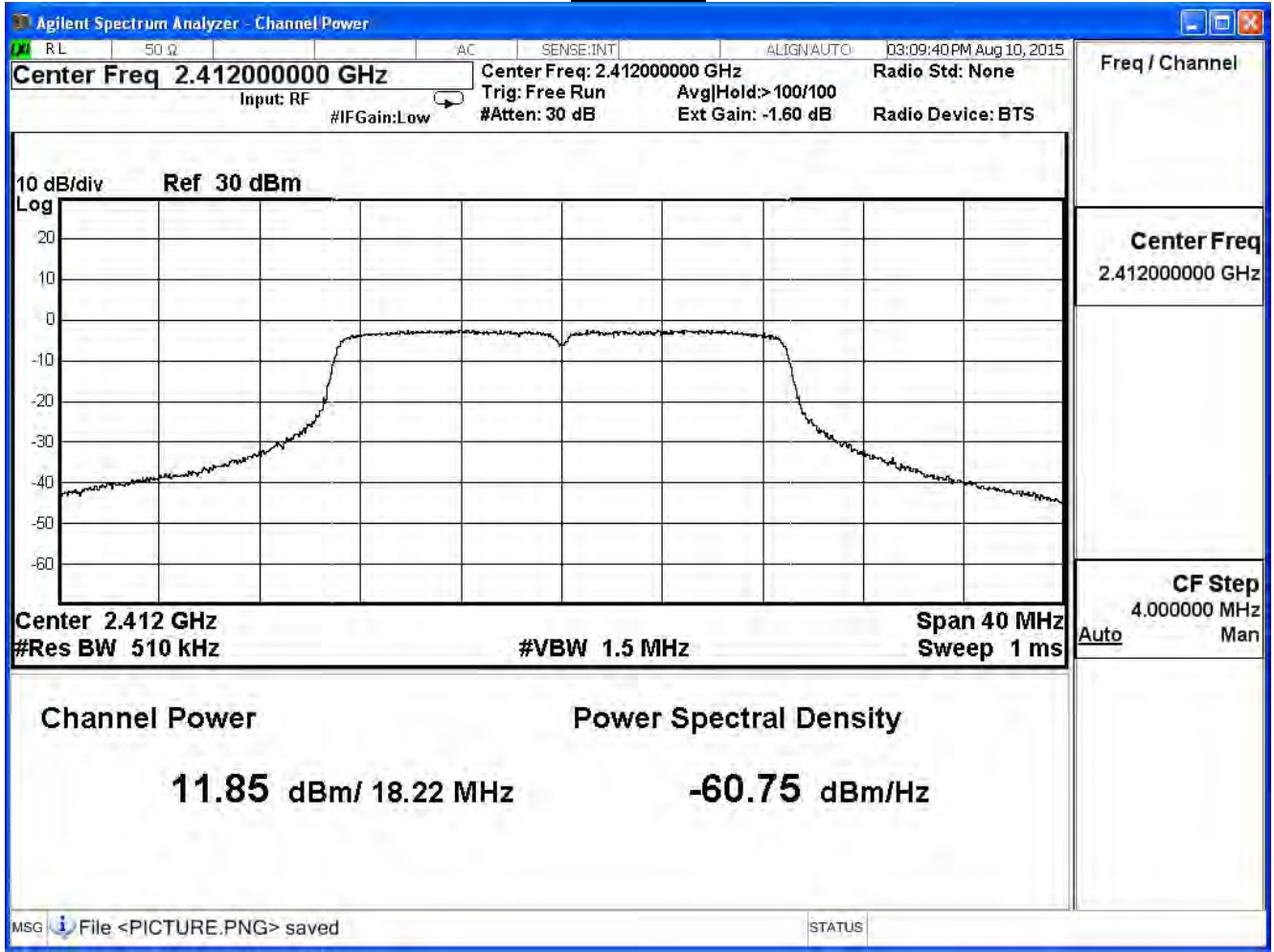

Channel 6

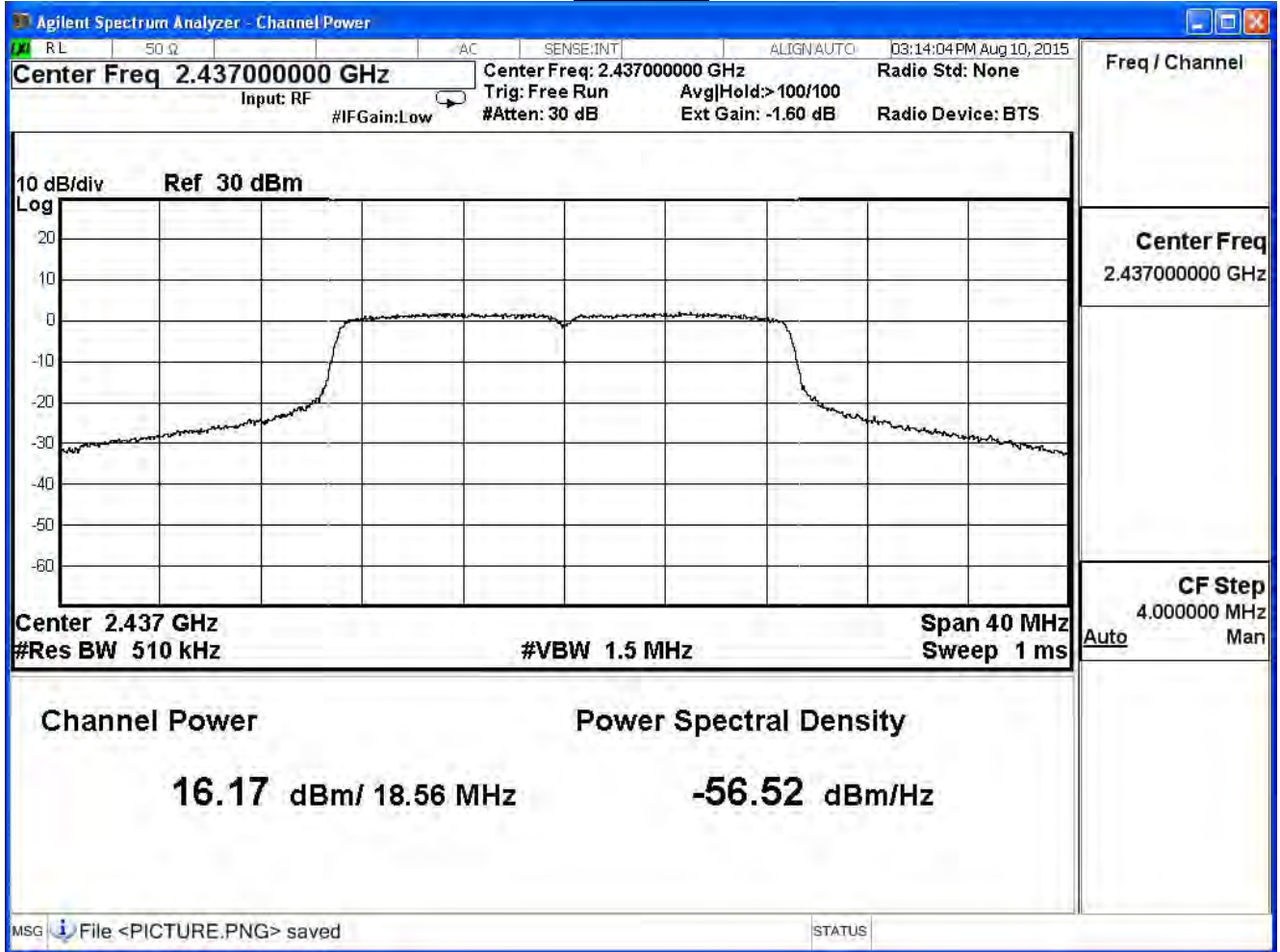

Channel 11

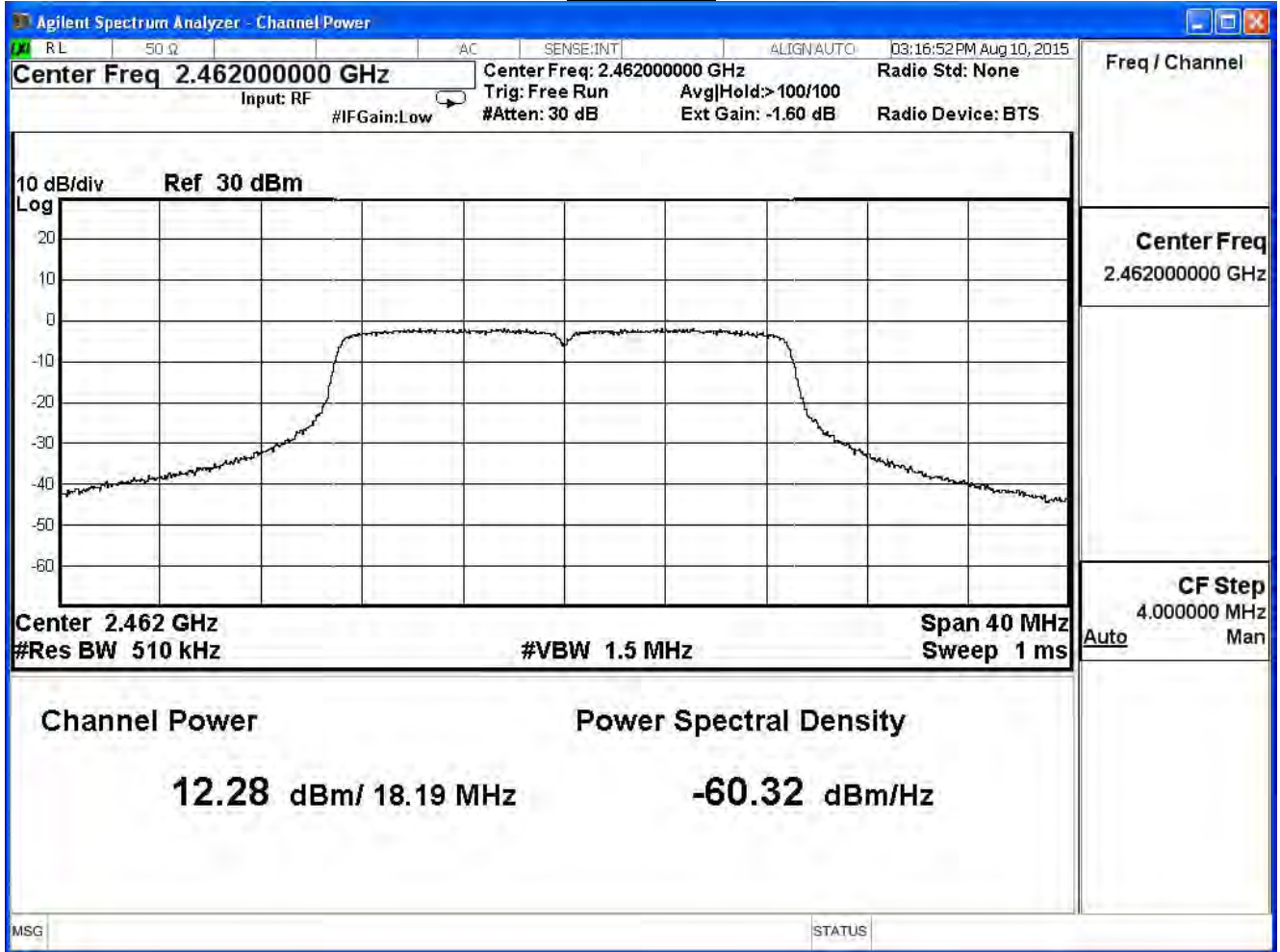

Product	ASUS SRT-AC1900 Wireless Smart Router		
Test Item	Peak Power Output		
Test Mode	Mode 1: Tx- AUX Antenna (AD891M21)		
Date of Test	2015/08/10	Test Site	SR7

IEEE 802.11n (40MHz) (ANT 0)

Channel No.	Frequency (MHz)	Measure Level (dBm)	Limit (dBm)	Result
3	2422	8.80	≤ 30	Pass
6	2437	12.26	≤ 30	Pass
9	2452	9.04	≤ 30	Pass

The worst emission of data rate is 13.5 Mbps.

Peak Power Output (dBm)										
MCS Index		0	1	2	3	4	5	6	7	Required Limit (dBm)
Channel No	Frequency (MHz)	Data Rate								
		13.5	27	40.5	54	81	108	121.5	135	
3	2422	8.80	--	--	--	--	--	--	--	≤ 30
6	2437	12.26	12.20	12.18	12.15	12.11	12.05	12.03	11.97	≤ 30
9	2452	9.04	--	--	--	--	--	--	--	≤ 30

Channel 3

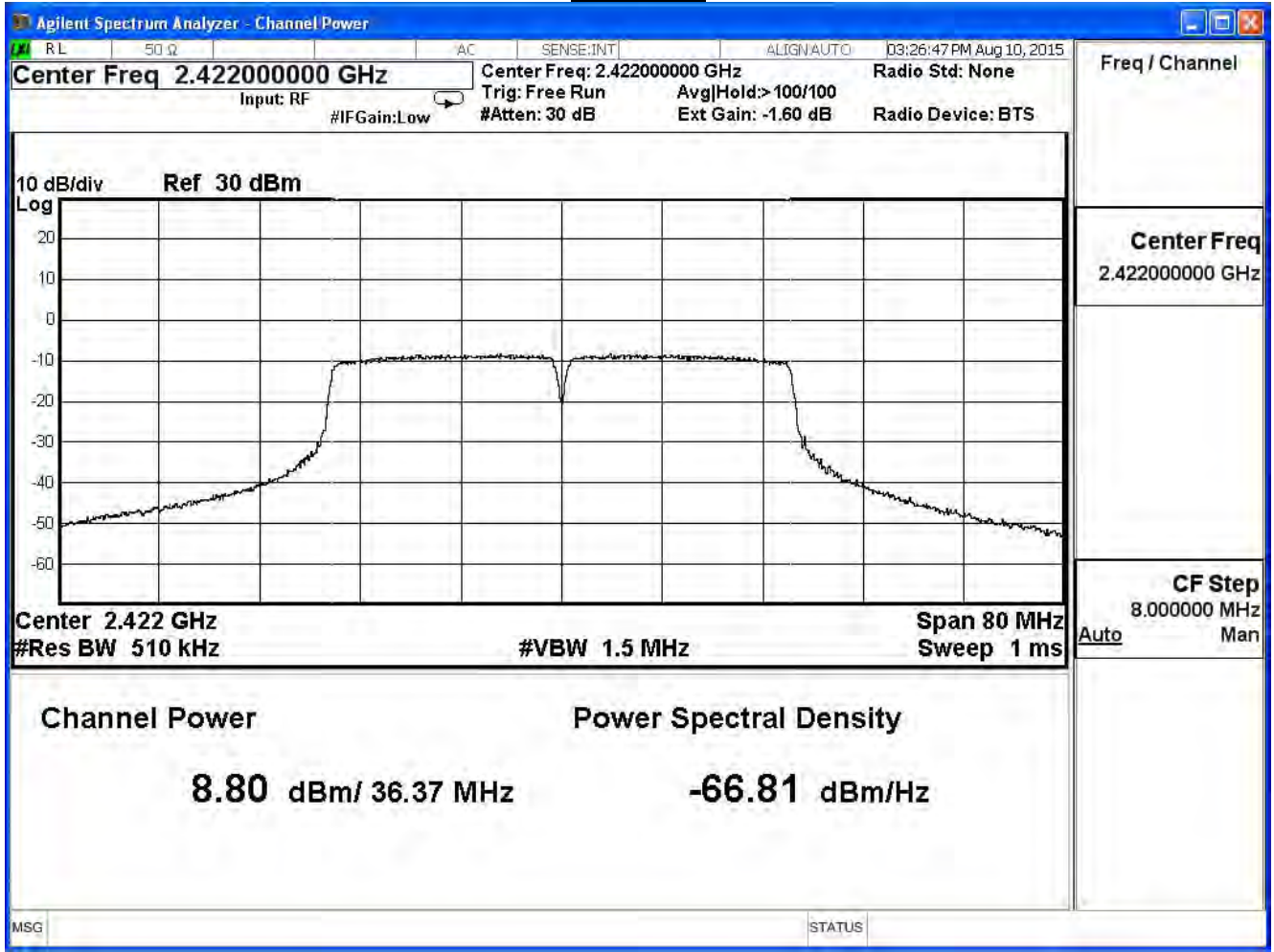

Channel 6

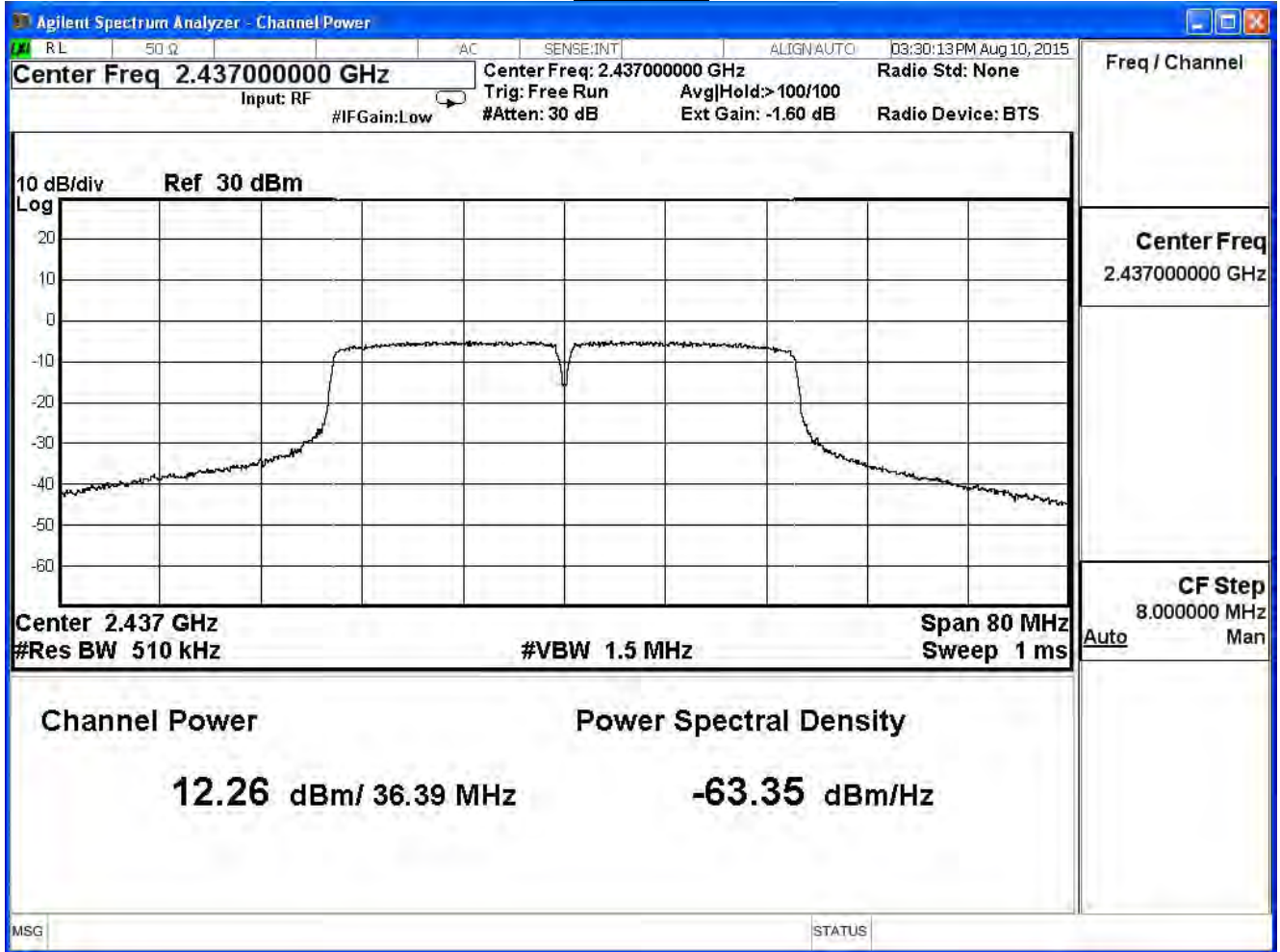

Channel 9

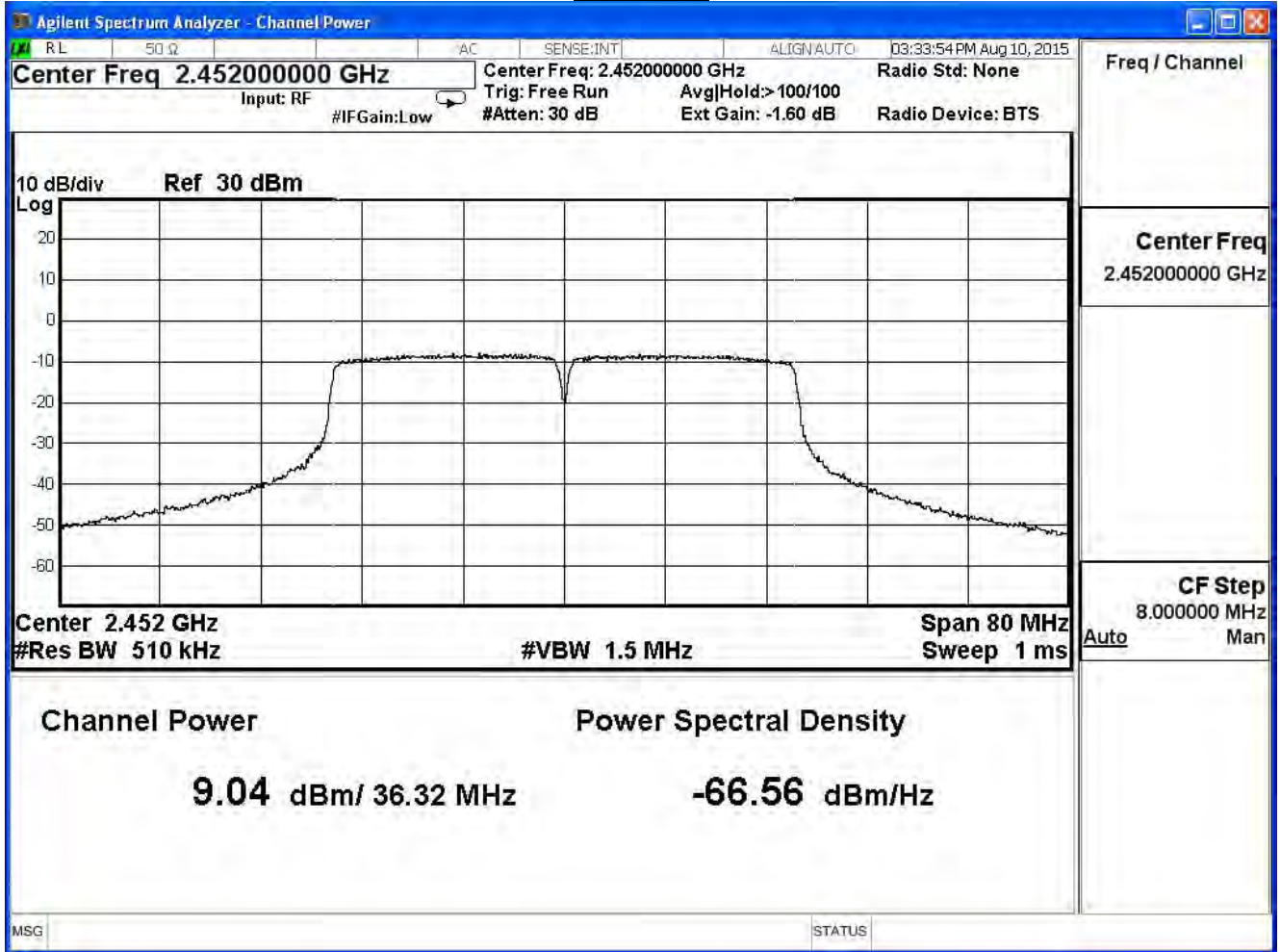

4. Radiated Emission

4.1. Test Equipment

The following test equipments are used during the test:

Radiated Emission / CB1

Instrument	Manufacturer	Model No.	Serial No	Next Cal. Date
Bilog Antenna	SCHAFFNER	CBL6112B	2895(CB1)	2016/08/14
Double Ridged Guide Horn Antenna	Schwarzback	BBHA 9120	D743	2016/01/26
Pre-Amplifier	EMCI	EMC0031835	980233	2016/01/18
Pre-Amplifier	QuieTek	AP-025C	CHM-0706049	2016/01/18
Spectrum Analyzer	Agilent	E4440A	MY46187335	2016/01/07
k Type Cable	Huber Suhner	SF 102	25623/2	2016/01/26

Note: 1. All equipments that need to calibrate are with calibration period of 1 year.

4.2. Test Setup

Under 1GHz Test Setup:

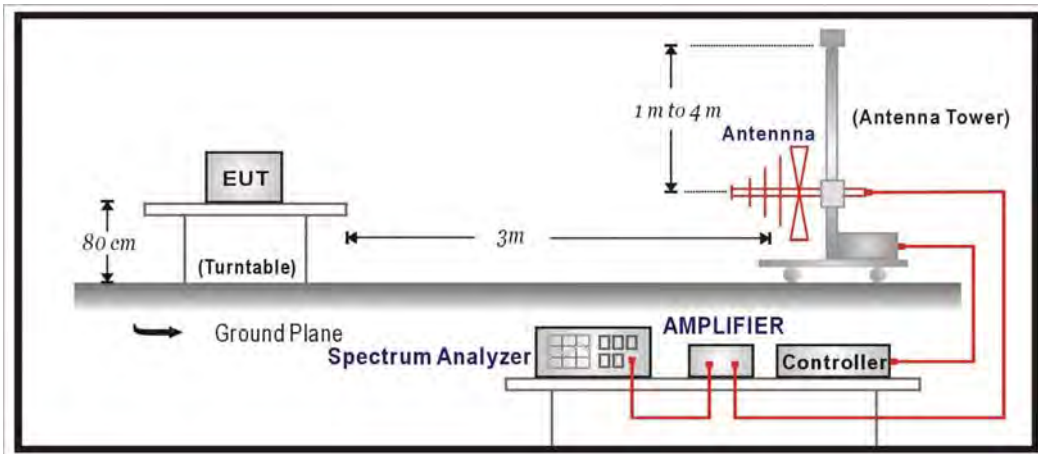

Above 1GHz Test Setup:

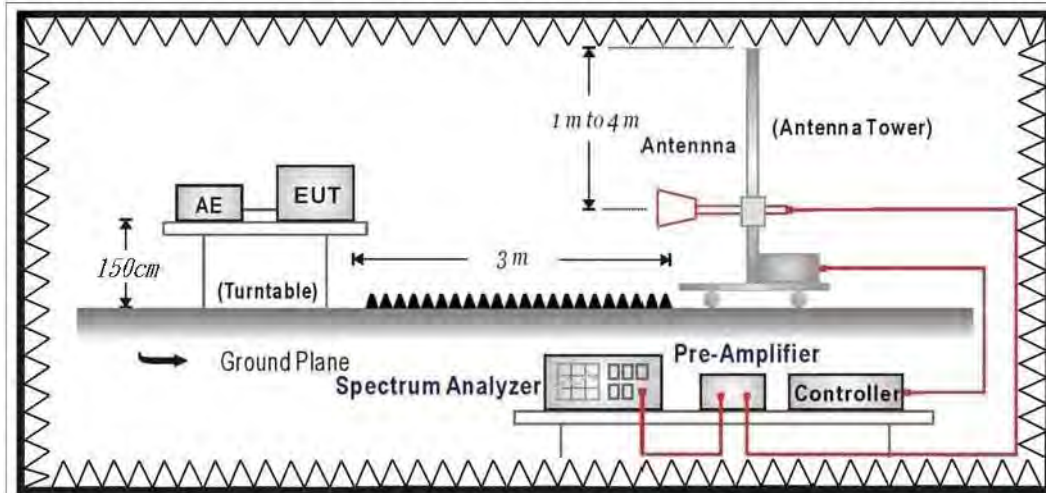

4.3. Limits

Emissions radiated outside of the specified frequency bands, except for harmonics, shall be attenuated by at least 20dB below the level of the fundamental or to the general radiated emission limits in paragraph 15.209, whichever is the lesser attenuation.

FCC Part 15 Subpart C Paragraph 15.209 Limits		
Frequency MHz	dBuV/m	dBuV/m
30-88	100	40
88-216	150	43.5
216-960	200	46
Above 960	500	54

Remarks: E field strength (dBuV/m) = 20 log E field strength (uV/m)

4.4. Test Procedure

The EUT was setup according to ANSI C63.10:2013 and tested according to DTS test procedure of KDB558074 v03r02 for compliance to FCC 47CFR 15.247 requirements. The EUT and its simulators are placed on a turn table which is 0.8 meter above ground (under 1GHz) or 1.5 meter above ground (above 1GHz). The turn table can rotate 360 degrees to determine the position of the maximum emission level.

The antenna can move up and down between 1 meter and 4 meters to find out the maximum emission level.

Both horizontal and vertical polarization of the antenna are set on measurement. In order to find the maximum emission, all of the interface cables must be manipulated according to ANSI C63.10:2013 on radiated measurement.

On any frequency or frequencies below or equal to 1000 MHz, the limits shown are based on measuring equipment employing a quasi-peak detector function and on any frequency or frequencies above 1000 MHz the radiated limits shown are based upon the use of measurement instrumentation employing an average detector function. When average radiated emission measurement are included emission measurement below 1000 MHz, there also is a limit on the radio frequency emissions, as measured using instrumentation with a peak detector function, corresponding to 20 dB above the maximum permitted average limit. The bandwidth below 1GHz setting on the field strength meter is 120 kHz and above 1GHz is 1MHz.

4.5. Test Specification

According to FCC Part 15 Subpart C Paragraph 15.247: 2014

4.6. Uncertainty

The measurement uncertainty

30MHz~1GHz as ±3.43dB

1GHz~26.5Ghz as ±3.65dB

4.7. Test Result

30MHz-1GHz Spurious

Site : CB1	Time : 2015/08/14 - 13:41
Limit : FCC_CLASS_B_03M_QP	Margin : 6
Probe : CB1_FCC_EFS_30-1G-2_1011 - HORIZONTAL	Power : AC 120V / 60Hz
EUT : ASUS SRT-AC1900 Wireless Smart Router	Note : Mode 1: Tx- AUX Antenna (AD891M21) 802.11b_2437MHz

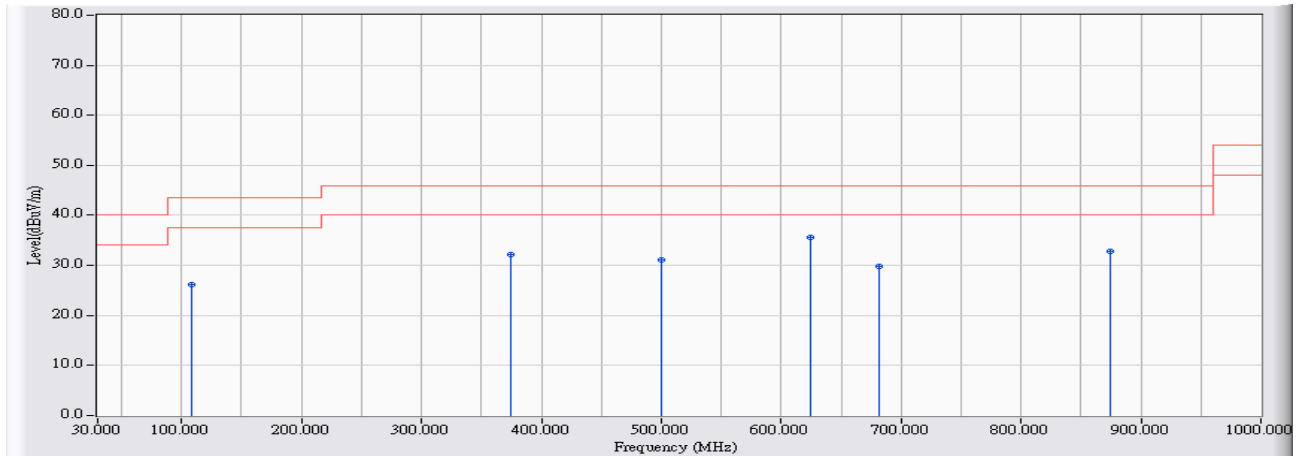

	Frequency (MHz)	Correct Factor (dB)	Reading Level (dBuV)	Measure Level (dBuV/m)	Margin (dB)	Limit (dBuV/m)	Detector Type
1	108.531	10.259	15.945	26.204	-17.296	43.500	QUASPEAK
2	374.663	14.546	17.692	32.238	-13.762	46.000	QUASPEAK
3	499.730	17.175	13.937	31.112	-14.888	46.000	QUASPEAK
4	* 624.798	17.610	18.029	35.639	-10.361	46.000	QUASPEAK
5	681.029	17.896	11.874	29.770	-16.230	46.000	QUASPEAK
6	874.933	19.407	13.511	32.918	-13.082	46.000	QUASPEAK

Note:

1. All Reading Levels are Quasi-Peak value.
2. “ * ”, means this data is the worst emission level.
3. Measurement Level = Reading Level + Correct Factor.

Site : CB1	Time : 2015/08/14 - 17:52
Limit : FCC_CLASS_B_03M_QP	Margin : 6
Probe : CB1_FCC_EFS_30-1G-2_1011 - VERTICAL	Power : AC 120V / 60Hz
EUT : ASUS SRT-AC1900 Wireless Smart Router	Note : Mode 1: Tx- AUX Antenna (AD891M21) 802.11b_2437MHz

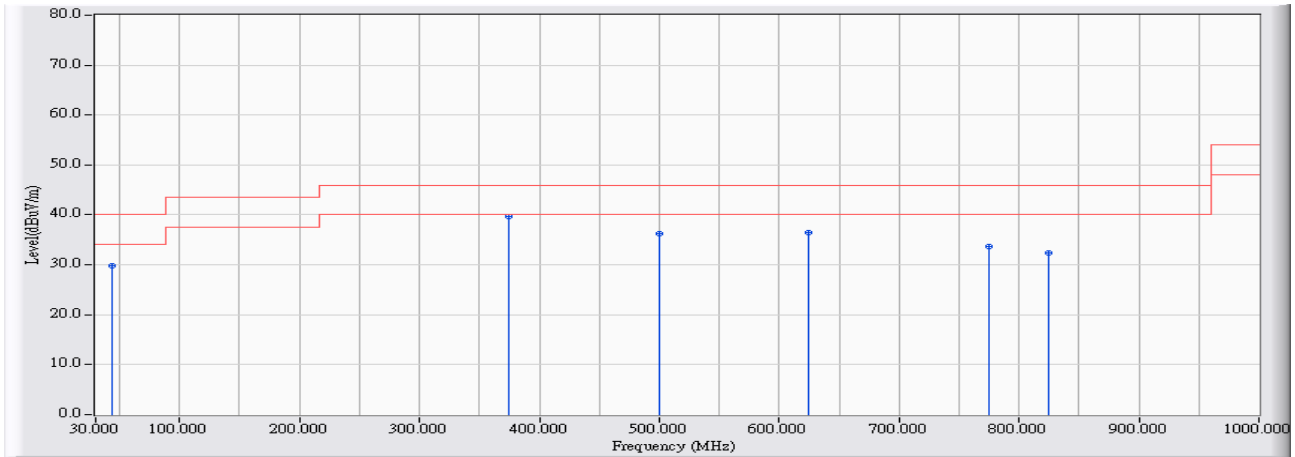

	Frequency (MHz)	Correct Factor (dB)	Reading Level (dBuV)	Measure Level (dBuV/m)	Margin (dB)	Limit (dBuV/m)	Detector Type
1	43.573	8.588	21.287	29.875	-10.125	40.000	QUASPEAK
2	* 374.663	14.546	25.091	39.637	-6.363	46.000	QUASPEAK
3	499.730	17.175	18.968	36.143	-9.857	46.000	QUASPEAK
4	624.798	17.610	18.918	36.528	-9.472	46.000	QUASPEAK
5	774.588	18.903	14.774	33.678	-12.322	46.000	QUASPEAK
6	825.002	19.279	13.062	32.341	-13.659	46.000	QUASPEAK

Note:

1. All Reading Levels are Quasi-Peak value.
2. “ * ”, means this data is the worst emission level.
3. Measurement Level = Reading Level + Correct Factor.

Site : CB1	Time : 2015/08/14 - 13:46
Limit : FCC_CLASS_B_03M_QP	Margin : 6
Probe : CB1_FCC_EFS_30-1G-2_1011 - HORIZONTAL	Power : AC 120V / 60Hz
EUT : ASUS SRT-AC1900 Wireless Smart Router	Note : Mode 1: Tx- AUX Antenna (AD891M21) 802.11g_2437MHz

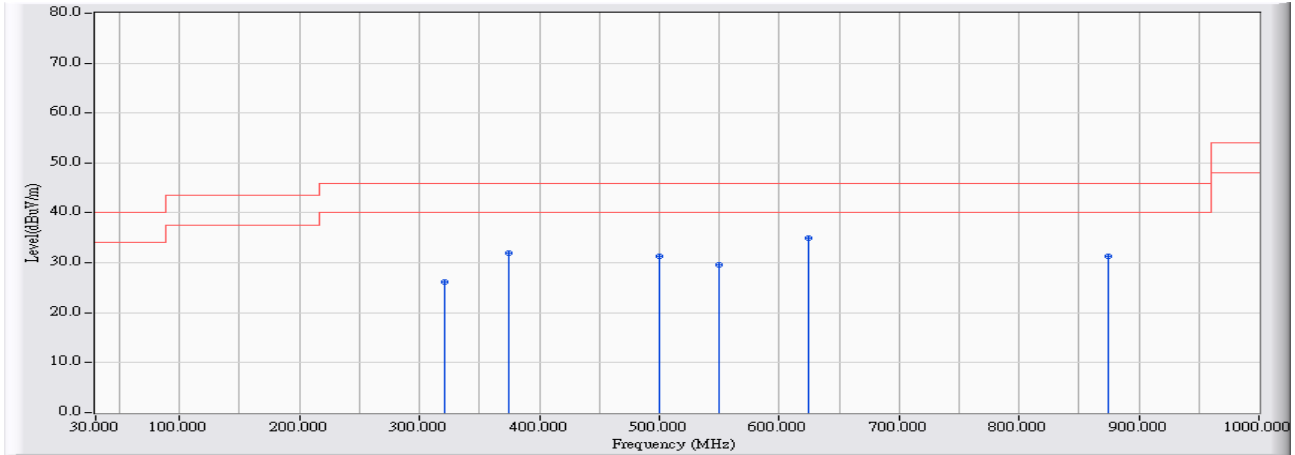

	Frequency (MHz)	Correct Factor (dB)	Reading Level (dBuV)	Measure Level (dBuV/m)	Margin (dB)	Limit (dBuV/m)	Detector Type
1	320.855	13.253	12.960	26.213	-19.787	46.000	QUASPEAK
2	374.663	14.546	17.484	32.030	-13.970	46.000	QUASPEAK
3	499.730	17.175	14.054	31.229	-14.771	46.000	QUASPEAK
4	549.660	17.332	12.243	29.575	-16.425	46.000	QUASPEAK
5	* 624.798	17.610	17.301	34.911	-11.089	46.000	QUASPEAK
6	874.933	19.407	11.895	31.302	-14.698	46.000	QUASPEAK

Note:

1. All Reading Levels are Quasi-Peak value.
2. “ * ”, means this data is the worst emission level.
3. Measurement Level = Reading Level + Correct Factor.

Site : CB1	Time : 2015/08/14 - 17:55
Limit : FCC_CLASS_B_03M_QP	Margin : 6
Probe : CB1_FCC_EFS_30-1G-2_1011 - VERTICAL	Power : AC 120V / 60Hz
EUT : ASUS SRT-AC1900 Wireless Smart Router	Note : Mode 1: Tx- AUX Antenna (AD891M21) 802.11g_2437MHz

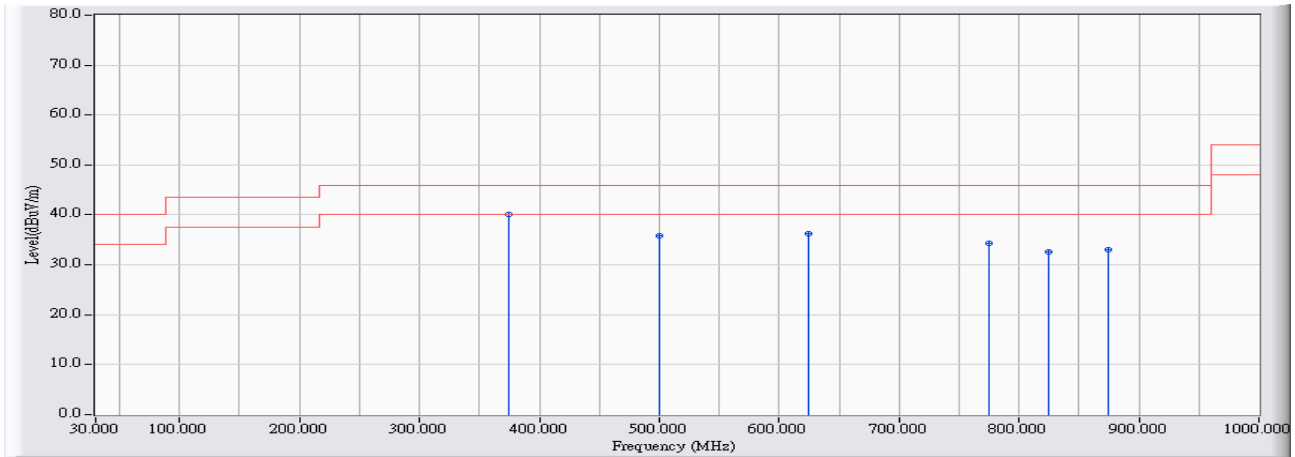

		Frequency (MHz)	Correct Factor (dB)	Reading Level (dBuV)	Measure Level (dBuV/m)	Margin (dB)	Limit (dBuV/m)	Detector Type
1	*	374.663	14.546	25.603	40.149	-5.851	46.000	QUASPEAK
2		499.730	17.175	18.661	35.836	-10.164	46.000	QUASPEAK
3		624.798	17.610	18.642	36.252	-9.748	46.000	QUASPEAK
4		774.588	18.903	15.406	34.310	-11.690	46.000	QUASPEAK
5		825.002	19.279	13.270	32.549	-13.451	46.000	QUASPEAK
6		874.933	19.407	13.640	33.047	-12.953	46.000	QUASPEAK

Note:

1. All Reading Levels are Quasi-Peak value.
2. “ * ”, means this data is the worst emission level.
3. Measurement Level = Reading Level + Correct Factor.

Site : CB1	Time : 2015/08/14 - 13:49
Limit : FCC_CLASS_B_03M_QP	Margin : 6
Probe : CB1_FCC_EFS_30-1G-2_1011 - HORIZONTAL	Power : AC 120V / 60Hz
EUT : ASUS SRT-AC1900 Wireless Smart Router	Note : Mode 1: Tx- AUX Antenna (AD891M21) 802.11n(20MHz)_2437MHz

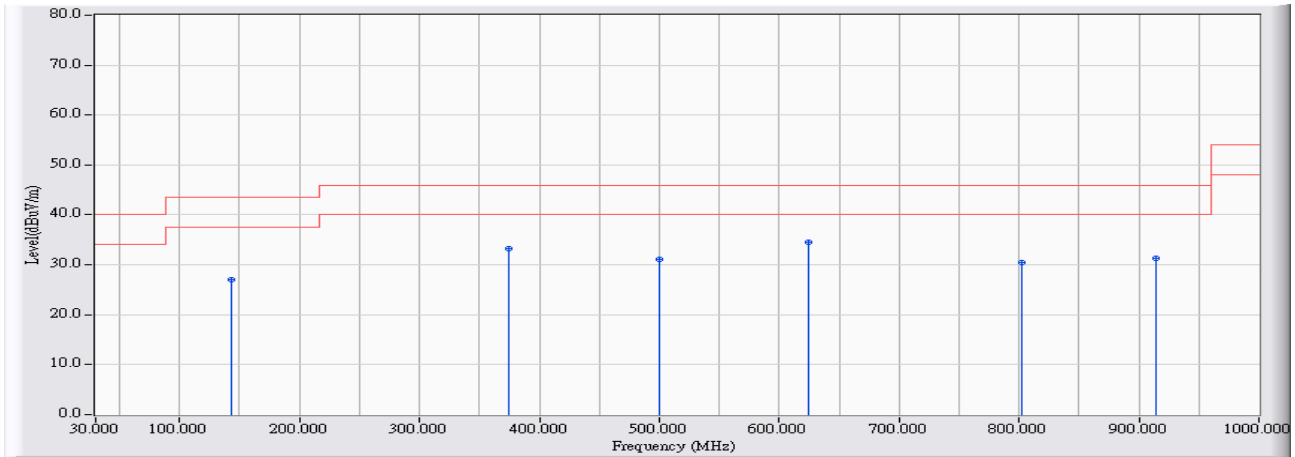

	Frequency (MHz)	Correct Factor (dB)	Reading Level (dBuV)	Measure Level (dBuV/m)	Margin (dB)	Limit (dBuV/m)	Detector Type
1	142.949	9.985	17.061	27.046	-16.454	43.500	QUASPEAK
2	374.663	14.546	18.681	33.227	-12.773	46.000	QUASPEAK
3	499.730	17.175	14.023	31.198	-14.802	46.000	QUASPEAK
4	* 624.798	17.610	16.963	34.573	-11.427	46.000	QUASPEAK
5	801.734	19.218	11.223	30.441	-15.559	46.000	QUASPEAK
6	913.713	19.584	11.678	31.262	-14.738	46.000	QUASPEAK

Note:

1. All Reading Levels are Quasi-Peak value.
2. “ * ”, means this data is the worst emission level.
3. Measurement Level = Reading Level + Correct Factor.

Site : CB1	Time : 2015/08/14 - 17:59
Limit : FCC_CLASS_B_03M_QP	Margin : 6
Probe : CB1_FCC_EFS_30-1G-2_1011 - VERTICAL	Power : AC 120V / 60Hz
EUT : ASUS SRT-AC1900 Wireless Smart Router	Note : Mode 1: Tx- AUX Antenna (AD891M21) 802.11n(20MHz)_2437MHz

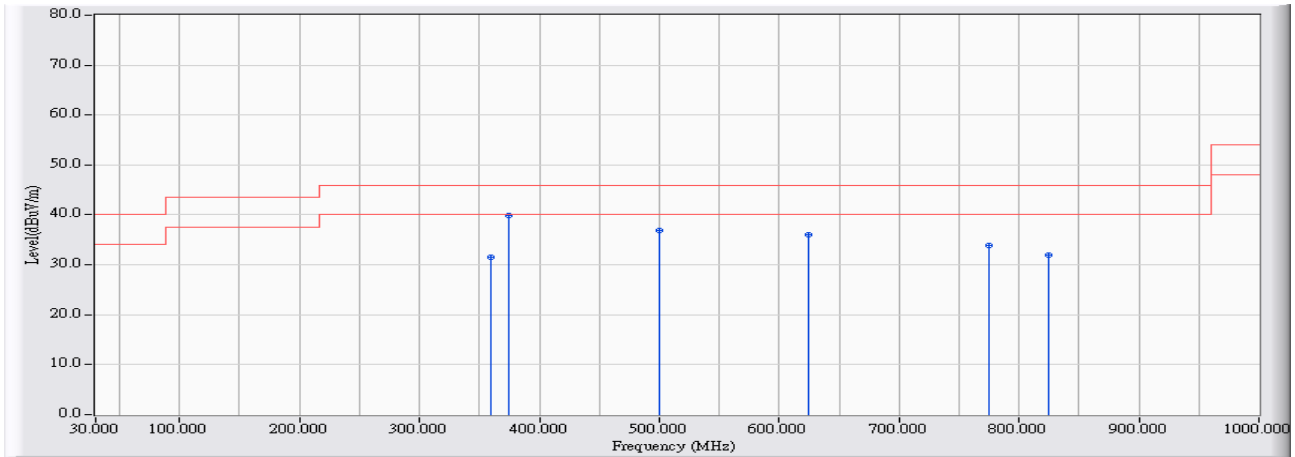

	Frequency (MHz)	Correct Factor (dB)	Reading Level (dBuV)	Measure Level (dBuV/m)	Margin (dB)	Limit (dBuV/m)	Detector Type
1	359.150	14.173	17.458	31.631	-14.369	46.000	QUASPEAK
2	* 374.663	14.546	25.419	39.965	-6.035	46.000	QUASPEAK
3	499.730	17.175	19.673	36.848	-9.152	46.000	QUASPEAK
4	624.798	17.610	18.342	35.952	-10.048	46.000	QUASPEAK
5	774.588	18.903	14.894	33.798	-12.202	46.000	QUASPEAK
6	825.002	19.279	12.712	31.991	-14.009	46.000	QUASPEAK

Note:

1. All Reading Levels are Quasi-Peak value.
2. " * ", means this data is the worst emission level.
3. Measurement Level = Reading Level + Correct Factor.

Site : CB1	Time : 2015/08/14 - 13:54
Limit : FCC_CLASS_B_03M_QP	Margin : 6
Probe : CB1_FCC_EFS_30-1G-2_1011 - HORIZONTAL	Power : AC 120V / 60Hz
EUT : ASUS SRT-AC1900 Wireless Smart Router	Note : Mode 1: Tx- AUX Antenna (AD891M21) 802.11n(40MHz)_2437MHz

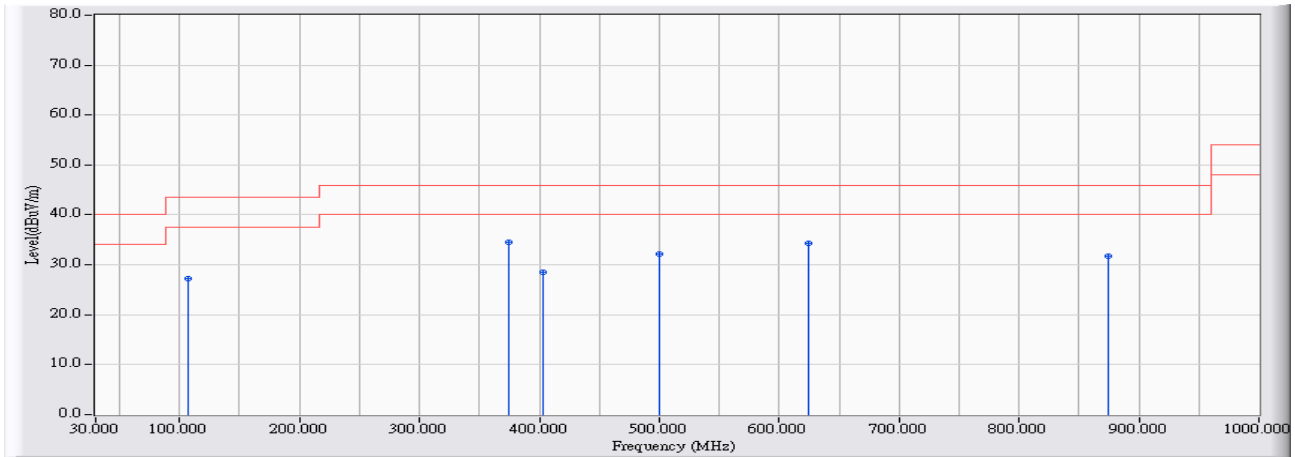

	Frequency (MHz)	Correct Factor (dB)	Reading Level (dBuV)	Measure Level (dBuV/m)	Margin (dB)	Limit (dBuV/m)	Detector Type
1	106.592	10.165	17.125	27.289	-16.211	43.500	QUASPEAK
2	* 374.663	14.546	19.887	34.433	-11.567	46.000	QUASPEAK
3	402.779	15.211	13.257	28.468	-17.532	46.000	QUASPEAK
4	499.730	17.175	14.947	32.122	-13.878	46.000	QUASPEAK
5	624.798	17.610	16.635	34.245	-11.755	46.000	QUASPEAK
6	874.933	19.407	12.415	31.822	-14.178	46.000	QUASPEAK

Note:

1. All Reading Levels are Quasi-Peak value.
2. “ * ”, means this data is the worst emission level.
3. Measurement Level = Reading Level + Correct Factor.

Site : CB1	Time : 2015/08/14 - 18:04
Limit : FCC_CLASS_B_03M_QP	Margin : 6
Probe : CB1_FCC_EFS_30-1G-2_1011 - VERTICAL	Power : AC 120V / 60Hz
EUT : ASUS SRT-AC1900 Wireless Smart Router	Note : Mode 1: Tx- AUX Antenna (AD891M21) 802.11n(40MHz)_2437MHz

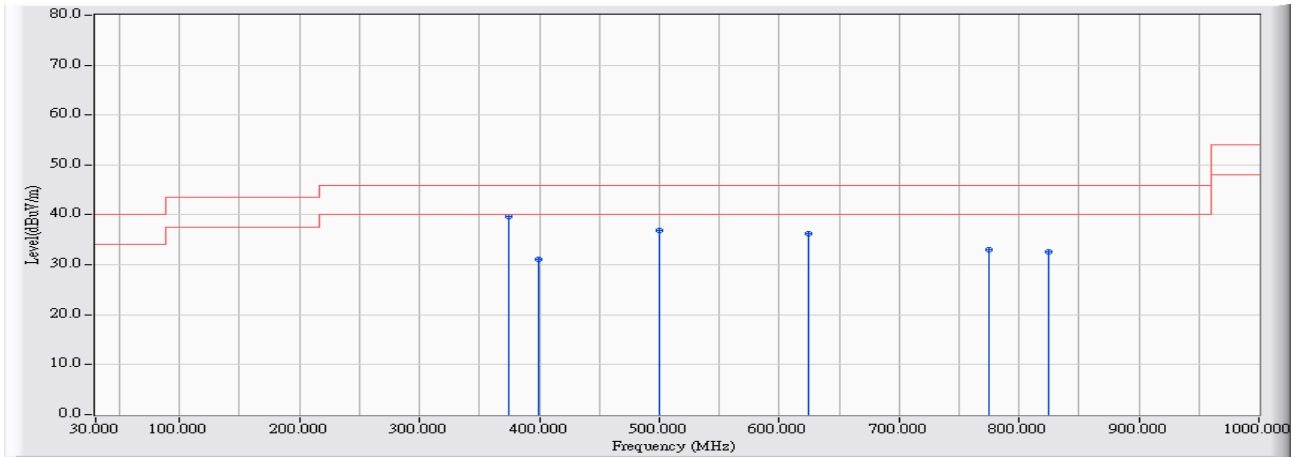

		Frequency (MHz)	Correct Factor (dB)	Reading Level (dBuV)	Measure Level (dBuV/m)	Margin (dB)	Limit (dBuV/m)	Detector Type
1	*	374.663	14.546	25.075	39.621	-6.379	46.000	QUASPEAK
2		399.870	15.150	15.893	31.044	-14.956	46.000	QUASPEAK
3		499.730	17.175	19.677	36.852	-9.148	46.000	QUASPEAK
4		624.798	17.610	18.685	36.295	-9.705	46.000	QUASPEAK
5		774.588	18.903	14.188	33.092	-12.908	46.000	QUASPEAK
6		825.002	19.279	13.357	32.636	-13.364	46.000	QUASPEAK

Note:

1. All Reading Levels are Quasi-Peak value.
2. “ * ”, means this data is the worst emission level.
3. Measurement Level = Reading Level + Correct Factor.

Site : CB1	Time : 2015/08/17 - 09:36
Limit : FCC_CLASS_B_03M_QP	Margin : 6
Probe : CB1_FCC_30M-1G-4_9161 - HORIZONTAL	Power : AC 120V / 60Hz
EUT : ASUS SRT-AC1900 Wireless Smart Router	Note : Mode 2: Tx- AUX Antenna (AD890326) 802.11b_2437MHz

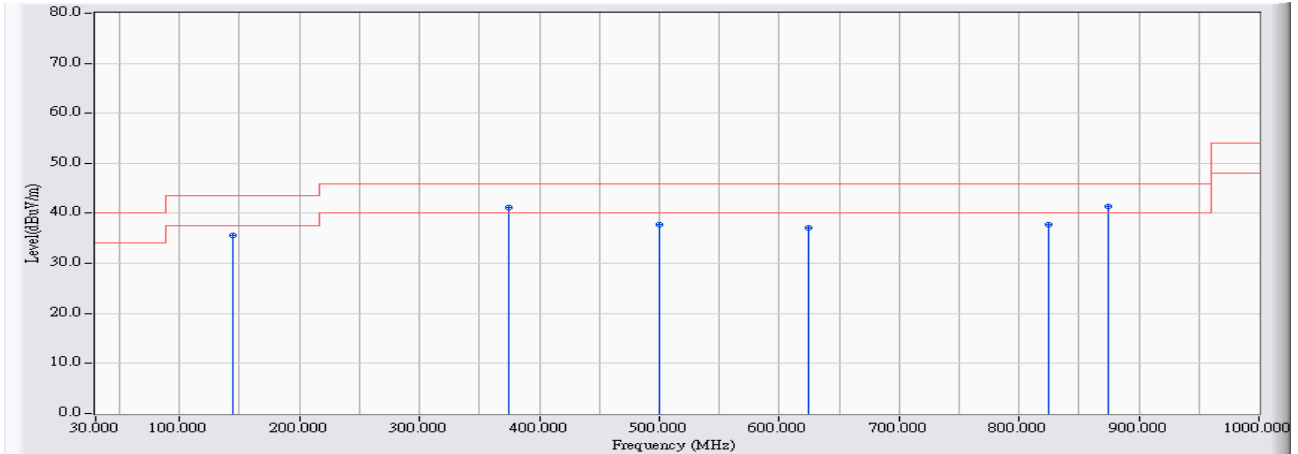

	Frequency (MHz)	Correct Factor (dB)	Reading Level (dBuV)	Measure Level (dBuV/m)	Margin (dB)	Limit (dBuV/m)	Detector Type
1	144.888	16.901	18.679	35.580	-7.920	43.500	QUASPEAK
2	374.663	15.384	25.846	41.230	-4.770	46.000	QUASPEAK
3	499.730	17.750	19.916	37.666	-8.334	46.000	QUASPEAK
4	624.798	20.041	17.065	37.105	-8.895	46.000	QUASPEAK
5	825.002	22.606	15.220	37.826	-8.174	46.000	QUASPEAK
6	* 874.933	23.169	18.320	41.489	-4.511	46.000	QUASPEAK

Note:

1. All Reading Levels are Quasi-Peak value.
2. “ * ”, means this data is the worst emission level.
3. Measurement Level = Reading Level + Correct Factor.

Site : CB1	Time : 2015/08/17 - 11:55
Limit : FCC_CLASS_B_03M_QP	Margin : 6
Probe : CB1_FCC_30M-1G-4_9161 - VERTICAL	Power : AC 120V / 60Hz
EUT : ASUS SRT-AC1900 Wireless Smart Router	Note : Mode 2: Tx- AUX Antenna (AD890326) 802.11b_2437MHz

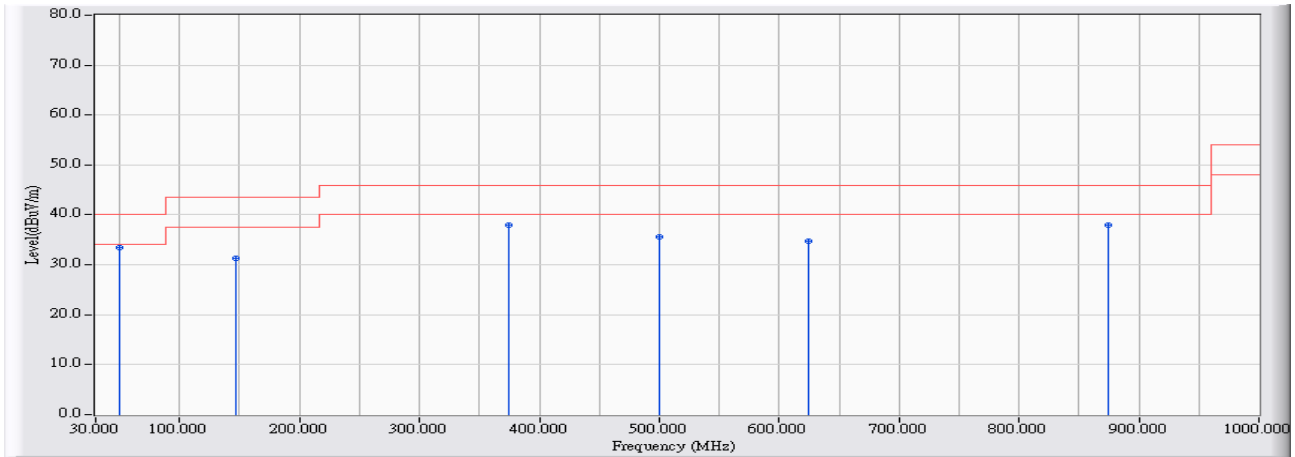

		Frequency (MHz)	Correct Factor (dB)	Reading Level (dBuV)	Measure Level (dBuV/m)	Margin (dB)	Limit (dBuV/m)	Detector Type
1	*	50.360	11.674	21.823	33.496	-6.504	40.000	QUASPEAK
2		146.342	17.151	14.245	31.396	-12.104	43.500	QUASPEAK
3		374.663	15.384	22.474	37.858	-8.142	46.000	QUASPEAK
4		499.730	17.750	17.886	35.636	-10.364	46.000	QUASPEAK
5		624.798	20.041	14.624	34.664	-11.336	46.000	QUASPEAK
6		874.933	23.169	14.809	37.978	-8.022	46.000	QUASPEAK

Note:

1. All Reading Levels are Quasi-Peak value.
2. “ * ”, means this data is the worst emission level.
3. Measurement Level = Reading Level + Correct Factor.

Site : CB1	Time : 2015/08/17 - 09:38
Limit : FCC_CLASS_B_03M_QP	Margin : 6
Probe : CB1_FCC_30M-1G-4_9161 - HORIZONTAL	Power : AC 120V / 60Hz
EUT : ASUS SRT-AC1900 Wireless Smart Router	Note : Mode 2: Tx- AUX Antenna (AD890326) 802.11g_2437MHz

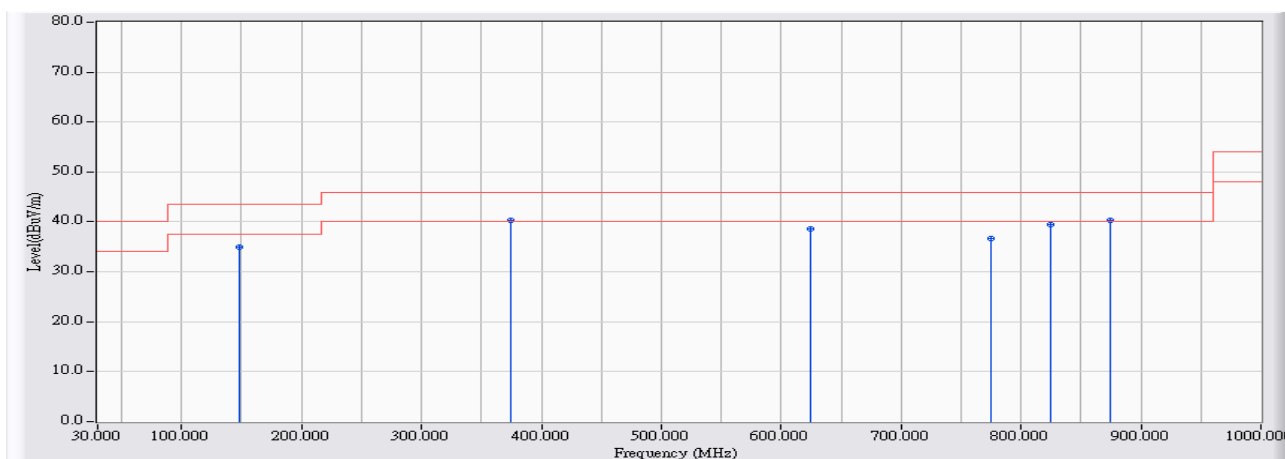

	Frequency (MHz)	Correct Factor (dB)	Reading Level (dBuV)	Measure Level (dBuV/m)	Margin (dB)	Limit (dBuV/m)	Detector Type
1	147.796	17.400	17.546	34.947	-8.553	43.500	QUASPEAK
2	374.663	15.384	25.011	40.395	-5.605	46.000	QUASPEAK
3	624.798	20.041	18.603	38.643	-7.357	46.000	QUASPEAK
4	774.588	22.003	14.707	36.710	-9.290	46.000	QUASPEAK
5	825.002	22.606	16.893	39.499	-6.501	46.000	QUASPEAK
6	* 874.933	23.169	17.247	40.416	-5.584	46.000	QUASPEAK

Note:

1. All Reading Levels are Quasi-Peak value.
2. " * ", means this data is the worst emission level.
3. Measurement Level = Reading Level + Correct Factor.

Site : CB1	Time : 2015/08/17 - 11:56
Limit : FCC_CLASS_B_03M_QP	Margin : 6
Probe : CB1_FCC_30M-1G-4_9161 - VERTICAL	Power : AC 120V / 60Hz
EUT : ASUS SRT-AC1900 Wireless Smart Router	Note : Mode 2: Tx- AUX Antenna (AD890326) 802.11g_2437MHz

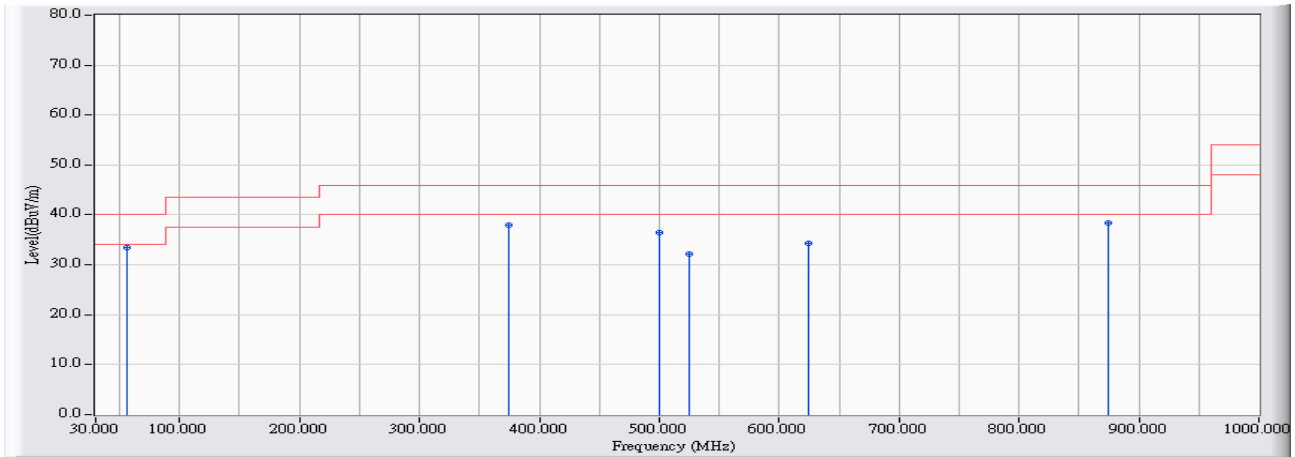

		Frequency (MHz)	Correct Factor (dB)	Reading Level (dBuV)	Measure Level (dBuV/m)	Margin (dB)	Limit (dBuV/m)	Detector Type
1	*	55.692	11.382	22.064	33.446	-6.554	40.000	QUASPEAK
2		374.663	15.384	22.662	38.046	-7.954	46.000	QUASPEAK
3		499.730	17.750	18.688	36.438	-9.562	46.000	QUASPEAK
4		524.938	18.239	13.994	32.233	-13.767	46.000	QUASPEAK
5		624.798	20.041	14.220	34.260	-11.740	46.000	QUASPEAK
6		874.933	23.169	15.248	38.417	-7.583	46.000	QUASPEAK

Note:

1. All Reading Levels are Quasi-Peak value.
2. “ * ”, means this data is the worst emission level.
3. Measurement Level = Reading Level + Correct Factor.

Site : CB1	Time : 2015/08/17 - 09:40
Limit : FCC_CLASS_B_03M_QP	Margin : 6
Probe : CB1_FCC_30M-1G-4_9161 - HORIZONTAL	Power : AC 120V / 60Hz
EUT : ASUS SRT-AC1900 Wireless Smart Router	Note : Mode 2: Tx- AUX Antenna (AD890326) 802.11n(20MHz)_2437MHz

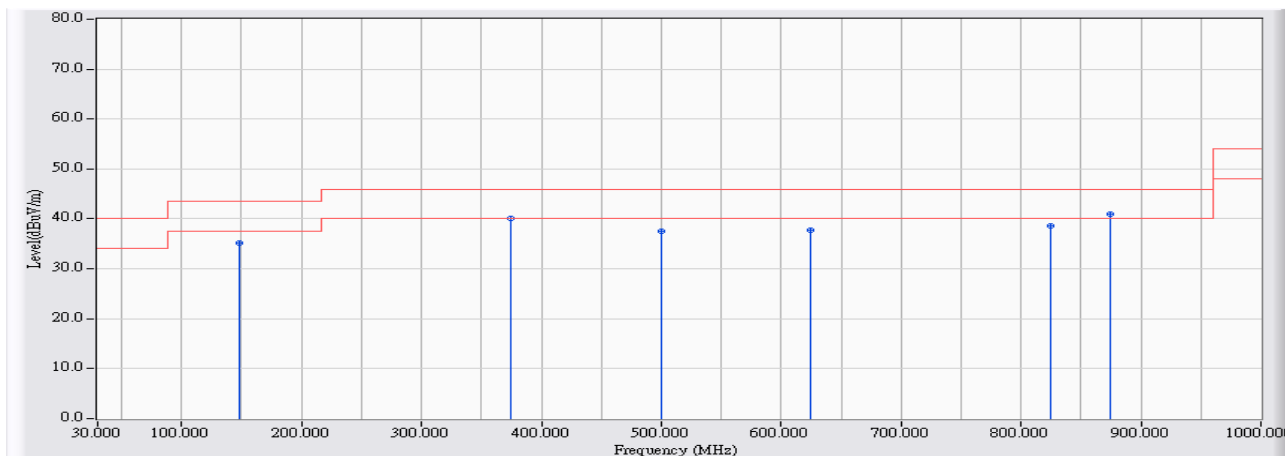

	Frequency (MHz)	Correct Factor (dB)	Reading Level (dBuV)	Measure Level (dBuV/m)	Margin (dB)	Limit (dBuV/m)	Detector Type
1	147.796	17.400	17.862	35.263	-8.237	43.500	QUASPEAK
2	374.663	15.384	24.660	40.044	-5.956	46.000	QUASPEAK
3	499.730	17.750	19.693	37.443	-8.557	46.000	QUASPEAK
4	624.798	20.041	17.713	37.753	-8.247	46.000	QUASPEAK
5	825.002	22.606	15.949	38.555	-7.445	46.000	QUASPEAK
6	* 874.933	23.169	17.790	40.959	-5.041	46.000	QUASPEAK

Note:

1. All Reading Levels are Quasi-Peak value.
2. “ * ”, means this data is the worst emission level.
3. Measurement Level = Reading Level + Correct Factor.

Site : CB1	Time : 2015/08/17 - 11:57
Limit : FCC_CLASS_B_03M_QP	Margin : 6
Probe : CB1_FCC_30M-1G-4_9161 - VERTICAL	Power : AC 120V / 60Hz
EUT : ASUS SRT-AC1900 Wireless Smart Router	Note : Mode 2: Tx- AUX Antenna (AD890326) 802.11n(20MHz)_2437MHz

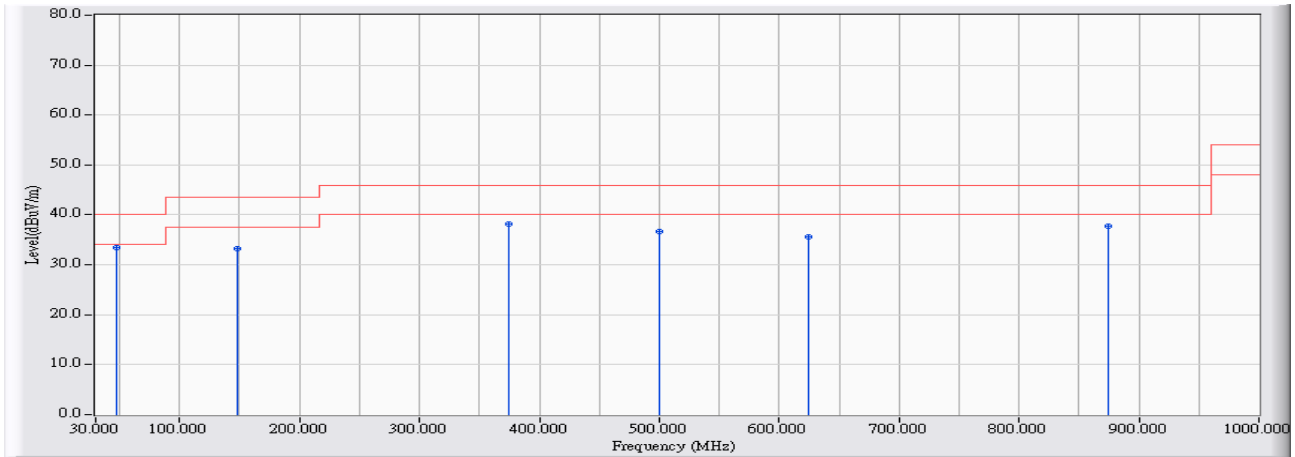

		Frequency (MHz)	Correct Factor (dB)	Reading Level (dBuV)	Measure Level (dBuV/m)	Margin (dB)	Limit (dBuV/m)	Detector Type
1	*	47.451	11.846	21.531	33.378	-6.622	40.000	QUASIPeAK
2		147.796	17.400	15.857	33.258	-10.242	43.500	QUASIPeAK
3		374.663	15.384	22.786	38.170	-7.830	46.000	QUASIPeAK
4		499.730	17.750	18.972	36.722	-9.278	46.000	QUASIPeAK
5		624.798	20.041	15.573	35.613	-10.387	46.000	QUASIPeAK
6		874.933	23.169	14.485	37.654	-8.346	46.000	QUASIPeAK

Note:

1. All Reading Levels are Quasi-Peak value.
2. “ * ”, means this data is the worst emission level.
3. Measurement Level = Reading Level + Correct Factor.

Site : CB1	Time : 2015/08/17 - 09:42
Limit : FCC_CLASS_B_03M_QP	Margin : 6
Probe : CB1_FCC_30M-1G-4_9161 - HORIZONTAL	Power : AC 120V / 60Hz
EUT : ASUS SRT-AC1900 Wireless Smart Router	Note : Mode 2: Tx- AUX Antenna (AD890326) 802.11n(40MHz)_2437MHz

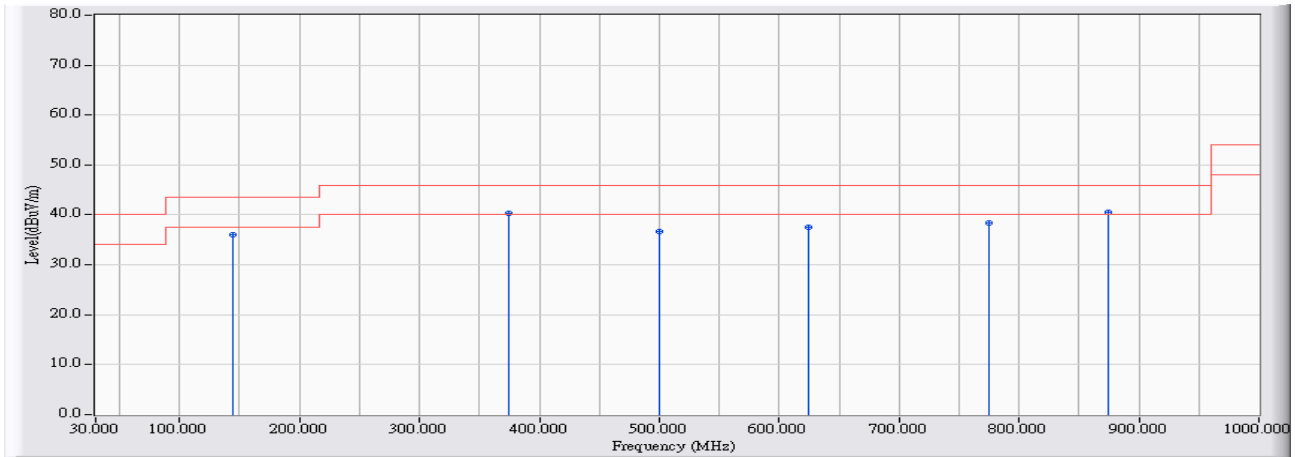

	Frequency (MHz)	Correct Factor (dB)	Reading Level (dBuV)	Measure Level (dBuV/m)	Margin (dB)	Limit (dBuV/m)	Detector Type
1	144.888	16.901	19.120	36.021	-7.479	43.500	QUASPEAK
2	374.663	15.384	24.883	40.267	-5.733	46.000	QUASPEAK
3	499.730	17.750	18.905	36.655	-9.345	46.000	QUASPEAK
4	624.798	20.041	17.437	37.477	-8.523	46.000	QUASPEAK
5	774.588	22.003	16.343	38.346	-7.654	46.000	QUASPEAK
6	* 874.933	23.169	17.366	40.535	-5.465	46.000	QUASPEAK

Note:

1. All Reading Levels are Quasi-Peak value.
2. “ * ”, means this data is the worst emission level.
3. Measurement Level = Reading Level + Correct Factor.

Site : CB1	Time : 2015/08/17 - 11:59
Limit : FCC_CLASS_B_03M_QP	Margin : 6
Probe : CB1_FCC_30M-1G-4_9161 - VERTICAL	Power : AC 120V / 60Hz
EUT : ASUS SRT-AC1900 Wireless Smart Router	Note : Mode 2: Tx- AUX Antenna (AD890326) 802.11n(40MHz)_2437MHz

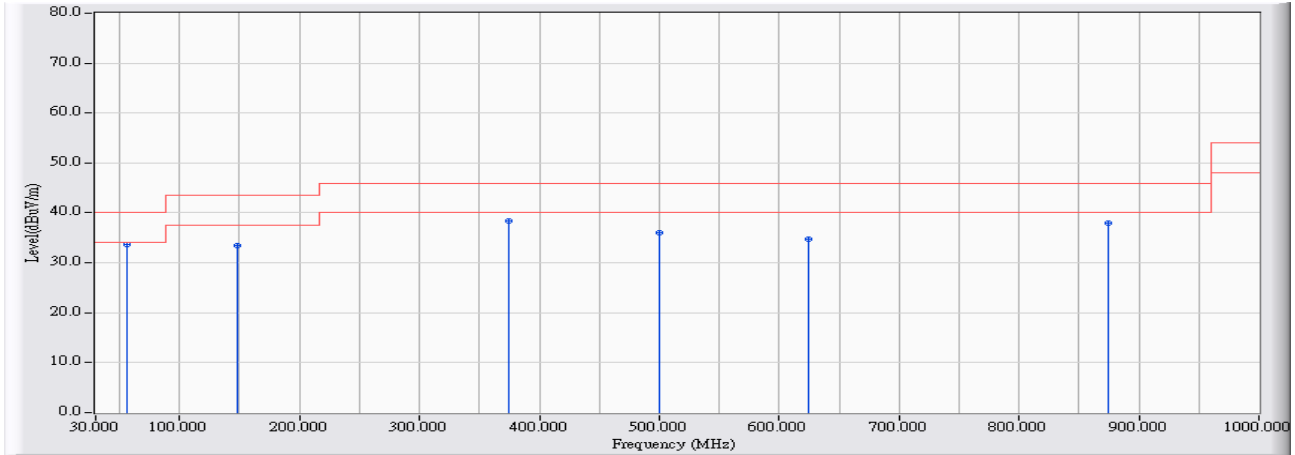

		Frequency (MHz)	Correct Factor (dB)	Reading Level (dBuV)	Measure Level (dBuV/m)	Margin (dB)	Limit (dBuV/m)	Detector Type
1	*	55.692	11.382	22.249	33.631	-6.369	40.000	QUASPEAK
2		147.796	17.400	15.963	33.364	-10.136	43.500	QUASPEAK
3		374.663	15.384	23.035	38.419	-7.581	46.000	QUASPEAK
4		499.730	17.750	18.222	35.972	-10.028	46.000	QUASPEAK
5		624.798	20.041	14.611	34.651	-11.349	46.000	QUASPEAK
6		874.933	23.169	14.732	37.901	-8.099	46.000	QUASPEAK

Note:

1. All Reading Levels are Quasi-Peak value.
2. “ * ”, means this data is the worst emission level.
3. Measurement Level = Reading Level + Correct Factor.

Site : CB1	Time : 2015/08/13 - 11:20
Limit : FCC_CLASS_B_03M_QP	Margin : 6
Probe : CB1_FCC_EFS_30-1G-2_1011 - HORIZONTAL	Power : AC 120V / 60Hz
EUT : ASUS SRT-AC1900 Wireless Smart Router	Note : Mode 3: Tx- AUX Antenna (ADP-33AW) 802.11b_2437MHz

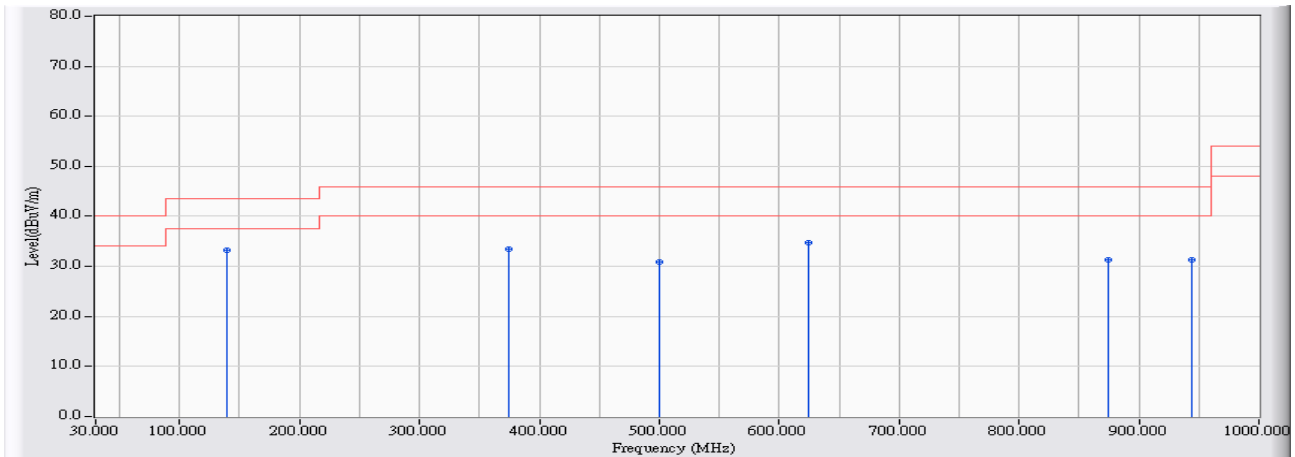

		Frequency (MHz)	Correct Factor (dB)	Reading Level (dBuV)	Measure Level (dBuV/m)	Margin (dB)	Limit (dBuV/m)	Detector Type
1	*	139.070	10.163	23.153	33.317	-10.183	43.500	QUASPEAK
2		374.663	14.546	18.950	33.496	-12.504	46.000	QUASPEAK
3		499.730	17.175	13.604	30.779	-15.221	46.000	QUASPEAK
4		624.798	17.610	17.147	34.757	-11.243	46.000	QUASPEAK
5		874.933	19.407	11.856	31.263	-14.737	46.000	QUASPEAK
6		943.768	19.830	11.492	31.322	-14.678	46.000	QUASPEAK

Note:

1. All Reading Levels are Quasi-Peak value.
2. “ * ”, means this data is the worst emission level.
3. Measurement Level = Reading Level + Correct Factor.

Site : CB1	Time : 2015/08/13 - 20:54
Limit : FCC_CLASS_B_03M_QP	Margin : 6
Probe : CB1_FCC_EFS_30-1G-2_1011 - VERTICAL	Power : AC 120V / 60Hz
EUT : ASUS SRT-AC1900 Wireless Smart Router	Note : Mode 3: Tx- AUX Antenna (ADP-33AW) 802.11b_2437MHz

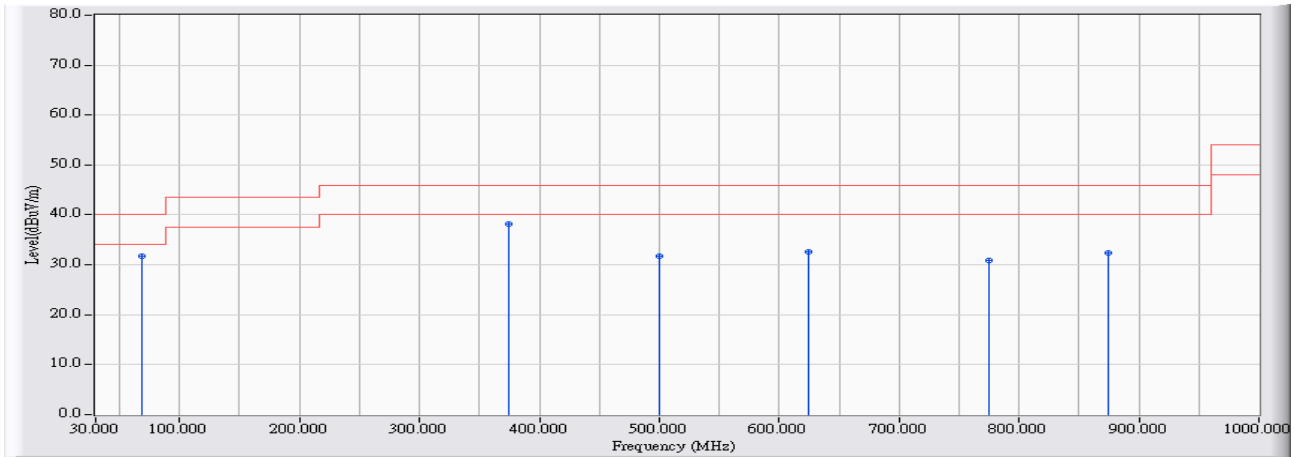

	Frequency (MHz)	Correct Factor (dB)	Reading Level (dBuV)	Measure Level (dBuV/m)	Margin (dB)	Limit (dBuV/m)	Detector Type
1	68.781	5.555	26.084	31.639	-8.361	40.000	QUASPEAK
2	* 374.663	14.546	23.620	38.166	-7.834	46.000	QUASPEAK
3	499.730	17.175	14.585	31.760	-14.240	46.000	QUASPEAK
4	624.798	17.610	15.069	32.679	-13.321	46.000	QUASPEAK
5	774.588	18.903	12.063	30.967	-15.033	46.000	QUASPEAK
6	874.933	19.407	12.923	32.330	-13.670	46.000	QUASPEAK

Note:

1. All Reading Levels are Quasi-Peak value.
2. " * ", means this data is the worst emission level.
3. Measurement Level = Reading Level + Correct Factor.

Site : CB1	Time : 2015/08/13 - 11:23
Limit : FCC_CLASS_B_03M_QP	Margin : 6
Probe : CB1_FCC_EFS_30-1G-2_1011 - HORIZONTAL	Power : AC 120V / 60Hz
EUT : ASUS SRT-AC1900 Wireless Smart Router	Note : Mode 3: Tx- AUX Antenna (ADP-33AW) 802.11g_2437MHz

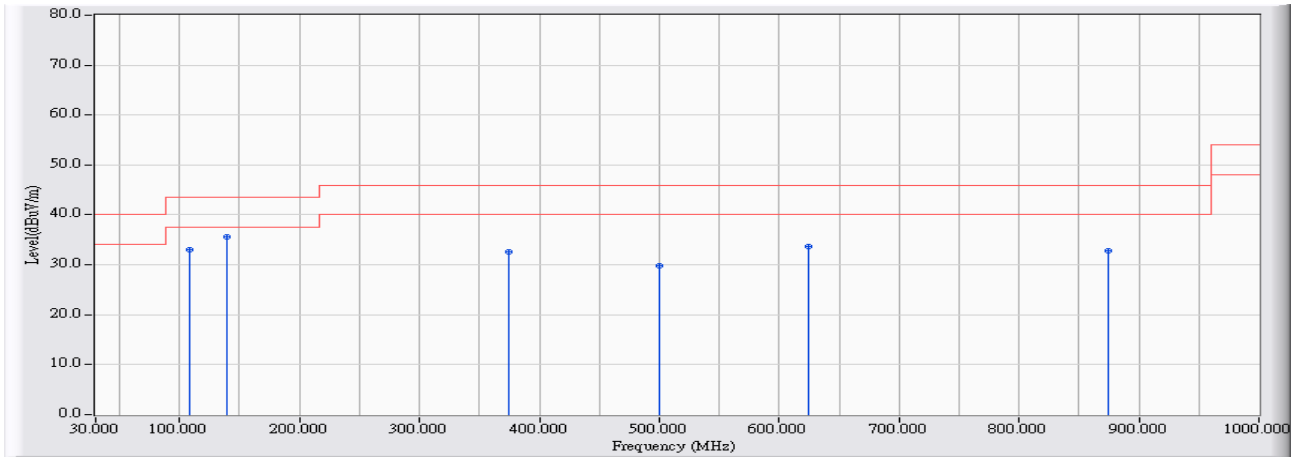

	Frequency (MHz)	Correct Factor (dB)	Reading Level (dBuV)	Measure Level (dBuV/m)	Margin (dB)	Limit (dBuV/m)	Detector Type
1	108.531	10.259	22.705	32.964	-10.536	43.500	QUASPEAK
2	* 139.070	10.163	25.447	35.611	-7.889	43.500	QUASPEAK
3	374.663	14.546	18.054	32.600	-13.400	46.000	QUASPEAK
4	499.730	17.175	12.536	29.711	-16.289	46.000	QUASPEAK
5	624.798	17.610	16.024	33.634	-12.366	46.000	QUASPEAK
6	874.933	19.407	13.310	32.717	-13.283	46.000	QUASPEAK

Note:

1. All Reading Levels are Quasi-Peak value.
2. “ * ”, means this data is the worst emission level.
3. Measurement Level = Reading Level + Correct Factor.

Site : CB1	Time : 2015/08/13 - 21:02
Limit : FCC_CLASS_B_03M_QP	Margin : 6
Probe : CB1_FCC_EFS_30-1G-2_1011 - VERTICAL	Power : AC 120V / 60Hz
EUT : ASUS SRT-AC1900 Wireless Smart Router	Note : Mode 3: Tx- AUX Antenna (ADP-33AW) 802.11g_2437MHz

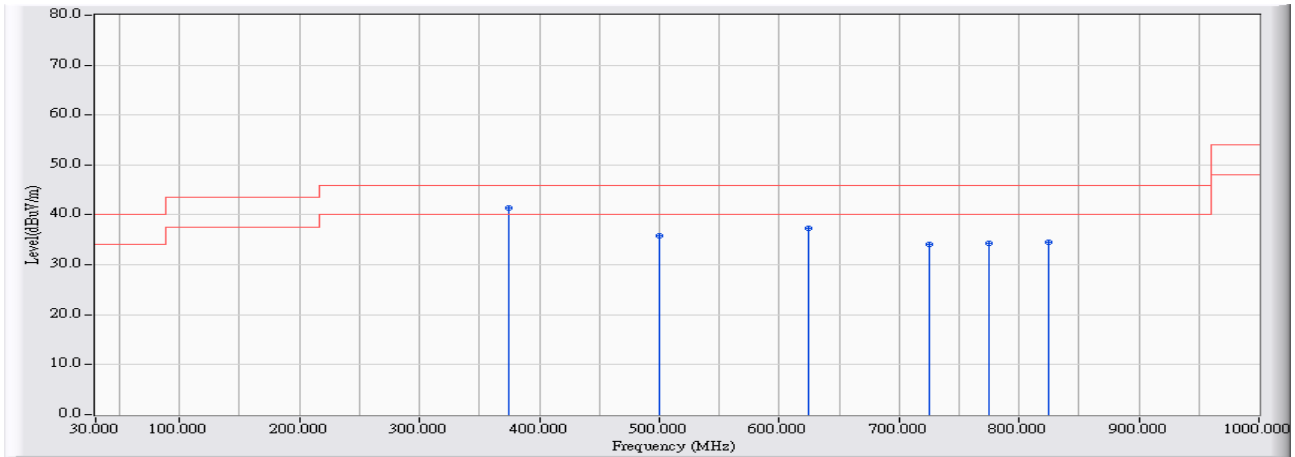

		Frequency (MHz)	Correct Factor (dB)	Reading Level (dBuV)	Measure Level (dBuV/m)	Margin (dB)	Limit (dBuV/m)	Detector Type
1	*	374.663	14.546	26.930	41.476	-4.524	46.000	QUASPEAK
2		499.730	17.175	18.536	35.711	-10.289	46.000	QUASPEAK
3		624.798	17.610	19.801	37.411	-8.589	46.000	QUASPEAK
4		724.658	18.293	15.796	34.090	-11.910	46.000	QUASPEAK
5		774.588	18.903	15.430	34.334	-11.666	46.000	QUASPEAK
6		825.002	19.279	15.349	34.628	-11.372	46.000	QUASPEAK

Note:

1. All Reading Levels are Quasi-Peak value.
2. “ * ”, means this data is the worst emission level.
3. Measurement Level = Reading Level + Correct Factor.

Site : CB1	Time : 2015/08/13 - 11:25
Limit : FCC_CLASS_B_03M_QP	Margin : 6
Probe : CB1_FCC_EFS_30-1G-2_1011 - HORIZONTAL	Power : AC 120V / 60Hz
EUT : ASUS SRT-AC1900 Wireless Smart Router	Note : Mode 3: Tx- AUX Antenna (ADP-33AW) 802.11n(20MHz)_2437MHz

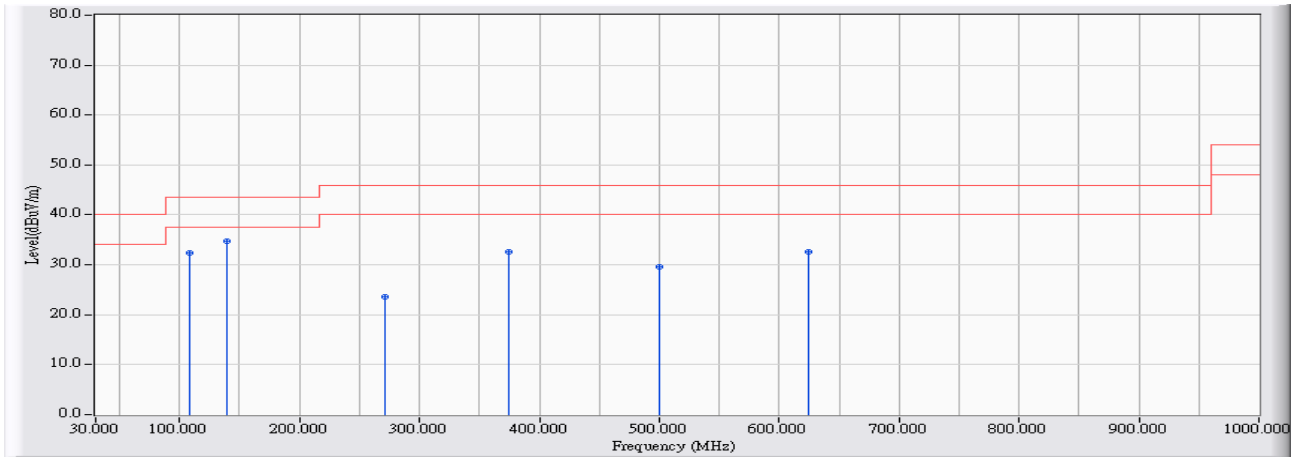

	Frequency (MHz)	Correct Factor (dB)	Reading Level (dBuV)	Measure Level (dBuV/m)	Margin (dB)	Limit (dBuV/m)	Detector Type
1	108.531	10.259	22.125	32.384	-11.116	43.500	QUASPEAK
2	* 139.070	10.163	24.664	34.828	-8.672	43.500	QUASPEAK
3	270.925	12.247	11.257	23.504	-22.496	46.000	QUASPEAK
4	374.663	14.546	18.016	32.562	-13.438	46.000	QUASPEAK
5	499.730	17.175	12.325	29.500	-16.500	46.000	QUASPEAK
6	624.798	17.610	14.895	32.505	-13.495	46.000	QUASPEAK

Note:

1. All Reading Levels are Quasi-Peak value.
2. “ * ”, means this data is the worst emission level.
3. Measurement Level = Reading Level + Correct Factor.

Site : CB1	Time : 2015/08/13 - 21:07
Limit : FCC_CLASS_B_03M_QP	Margin : 6
Probe : CB1_FCC_EFS_30-1G-2_1011 - VERTICAL	Power : AC 120V / 60Hz
EUT : ASUS SRT-AC1900 Wireless Smart Router	Note : Mode 3: Tx- AUX Antenna (ADP-33AW) 802.11n(20MHz)_2437MHz

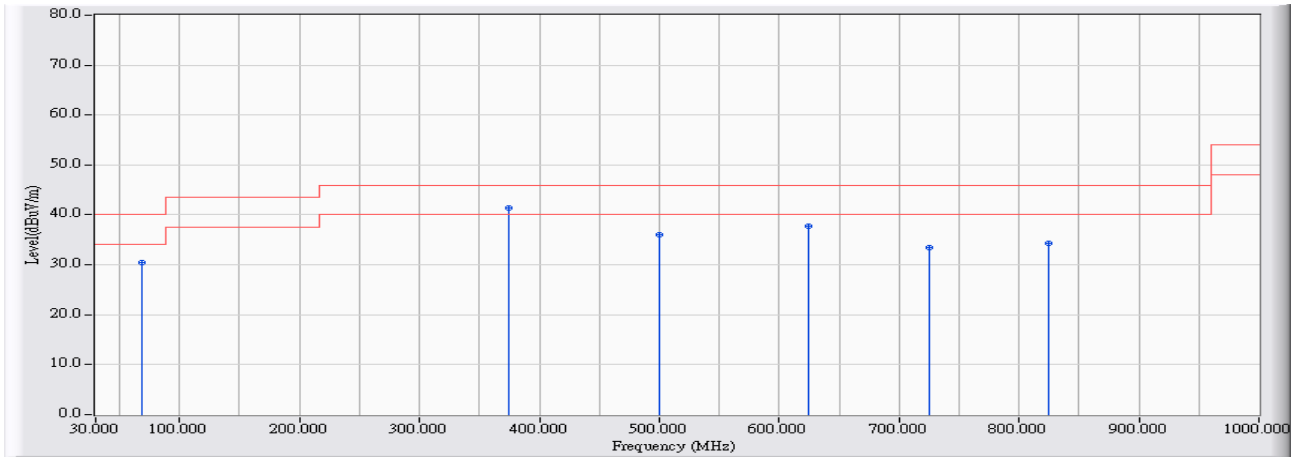

	Frequency (MHz)	Correct Factor (dB)	Reading Level (dBuV)	Measure Level (dBuV/m)	Margin (dB)	Limit (dBuV/m)	Detector Type
1	68.781	5.555	24.978	30.533	-9.467	40.000	QUASPEAK
2	* 374.663	14.546	26.854	41.400	-4.600	46.000	QUASPEAK
3	499.730	17.175	18.895	36.070	-9.930	46.000	QUASPEAK
4	624.798	17.610	20.153	37.763	-8.237	46.000	QUASPEAK
5	724.658	18.293	15.221	33.515	-12.485	46.000	QUASPEAK
6	825.002	19.279	15.083	34.362	-11.638	46.000	QUASPEAK

Note:

1. All Reading Levels are Quasi-Peak value.
2. “ * ”, means this data is the worst emission level.
3. Measurement Level = Reading Level + Correct Factor.

Site : CB1	Time : 2015/08/13 - 11:26
Limit : FCC_CLASS_B_03M_QP	Margin : 6
Probe : CB1_FCC_EFS_30-1G-2_1011 - HORIZONTAL	Power : AC 120V / 60Hz
EUT : ASUS SRT-AC1900 Wireless Smart Router	Note : Mode 3: Tx- AUX Antenna (ADP-33AW) 802.11n(40MHz)_2437MHz

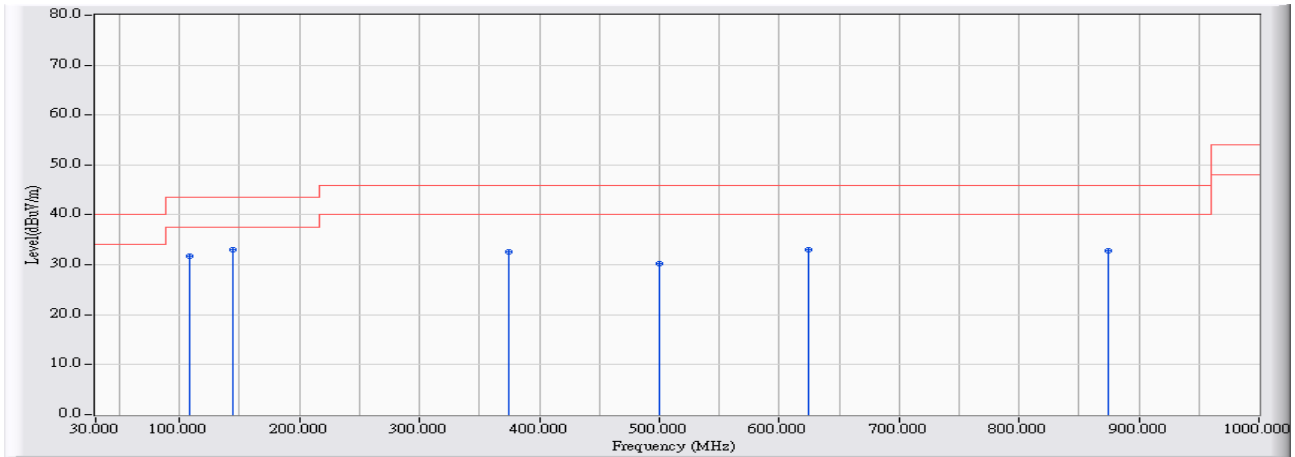

	Frequency (MHz)	Correct Factor (dB)	Reading Level (dBuV)	Measure Level (dBuV/m)	Margin (dB)	Limit (dBuV/m)	Detector Type
1	108.531	10.259	21.452	31.711	-11.789	43.500	QUASPEAK
2	* 144.888	9.888	23.045	32.934	-10.566	43.500	QUASPEAK
3	374.663	14.546	18.108	32.654	-13.346	46.000	QUASPEAK
4	499.730	17.175	13.090	30.265	-15.735	46.000	QUASPEAK
5	624.798	17.610	15.327	32.937	-13.063	46.000	QUASPEAK
6	874.933	19.407	13.378	32.785	-13.215	46.000	QUASPEAK

Note:

1. All Reading Levels are Quasi-Peak value.
2. “ * ”, means this data is the worst emission level.
3. Measurement Level = Reading Level + Correct Factor.

Site : CB1	Time : 2015/08/13 - 21:13
Limit : FCC_CLASS_B_03M_QP	Margin : 6
Probe : CB1_FCC_EFS_30-1G-2_1011 - VERTICAL	Power : AC 120V / 60Hz
EUT : ASUS SRT-AC1900 Wireless Smart Router	Note : Mode 3: Tx- AUX Antenna (ADP-33AW) 802.11n(40MHz)_2437MHz

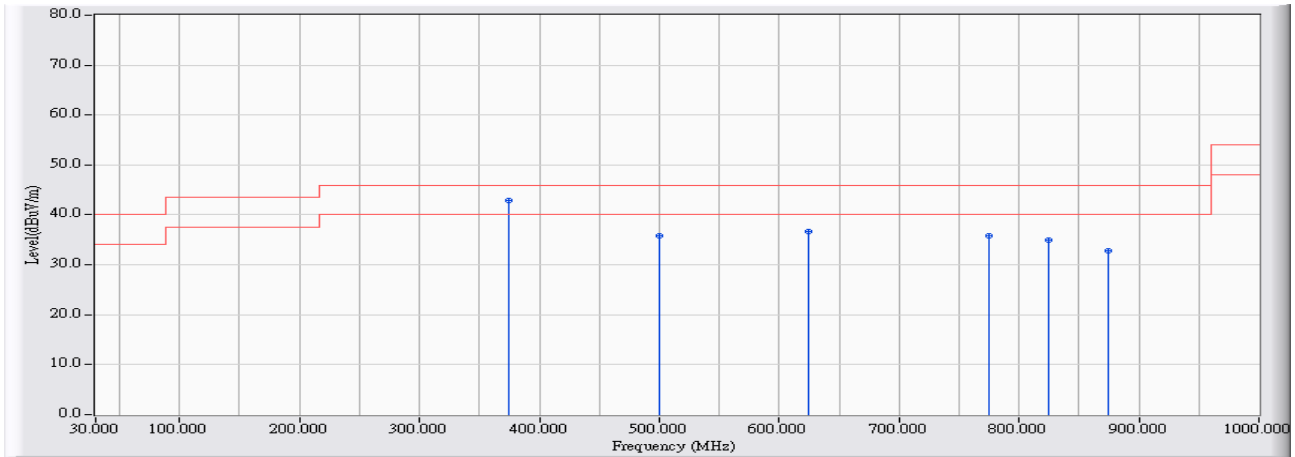

		Frequency (MHz)	Correct Factor (dB)	Reading Level (dBuV)	Measure Level (dBuV/m)	Margin (dB)	Limit (dBuV/m)	Detector Type
1	*	374.663	14.546	28.417	42.963	-3.037	46.000	QUASPEAK
2		499.730	17.175	18.687	35.862	-10.138	46.000	QUASPEAK
3		624.798	17.610	19.122	36.732	-9.268	46.000	QUASPEAK
4		774.588	18.903	16.970	35.874	-10.126	46.000	QUASPEAK
5		825.002	19.279	15.688	34.967	-11.033	46.000	QUASPEAK
6		874.933	19.407	13.346	32.753	-13.247	46.000	QUASPEAK

Note:

1. All Reading Levels are Quasi-Peak value.
2. “ * ”, means this data is the worst emission level.
3. Measurement Level = Reading Level + Correct Factor.

Above 1GHz Spurious

Site : CB1	Time : 2015/07/29 - 03:09
Limit : FCC_SpartC_15.247_H_03M_PK	Margin : 6
Probe : CB1_FCC_EFS_1-18G_H2 - HORIZONTAL	Power : AC 120 V / 60Hz
EUT : ASUS SRT-AC1900 Wireless Smart Router	Note : Mode 1: Tx- AUX Antenna (AD891M21) 802.11b_2412MHz

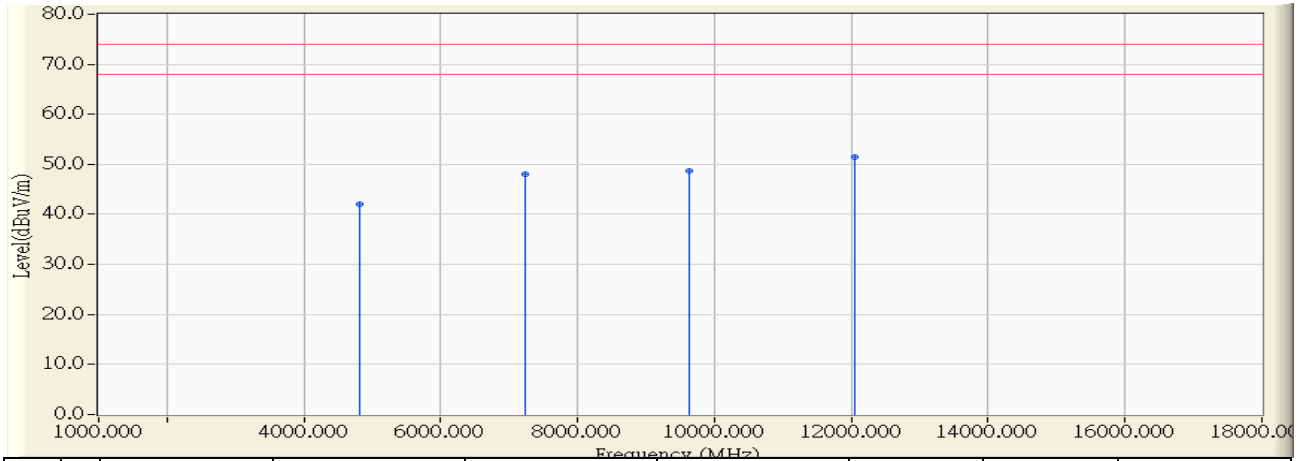

	Frequency (MHz)	Correct Factor (dB)	Reading Level (dBuV)	Measure Level (dBuV/m)	Margin (dB)	Limit (dBuV/m)	Detector Type
1	4824.006	-2.559	44.550	41.991	-32.009	74.000	PEAK
2	7235.120	5.924	42.220	48.144	-25.856	74.000	PEAK
3	9631.010	7.566	41.050	48.617	-25.383	74.000	PEAK
4	* 12060.510	10.337	41.050	51.387	-22.613	74.000	PEAK

Note:

1. All readings above 1GHz are performed with peak and/or average measurements as necessary.
2. “ * ”, means this data is the worst emission level.
3. Measurement Level = Reading Level + Correct Factor.
4. The average measurement was not performed when the peak measured data under the limit of average detection.
5. The Emission above 18GHz were not included because their levels is far less than the limit.

Site : CB1	Time : 2015/07/29 - 03:16
Limit : FCC_SpartC_15.247_H_03M_PK	Margin : 6
Probe : CB1_FCC_EFS_1-18G_H2 - VERTICAL	Power : AC 120 V / 60Hz
EUT : ASUS SRT-AC1900 Wireless Smart Router	Note : Mode 1: Tx- AUX Antenna (AD891M21) 802.11b_2412MHz

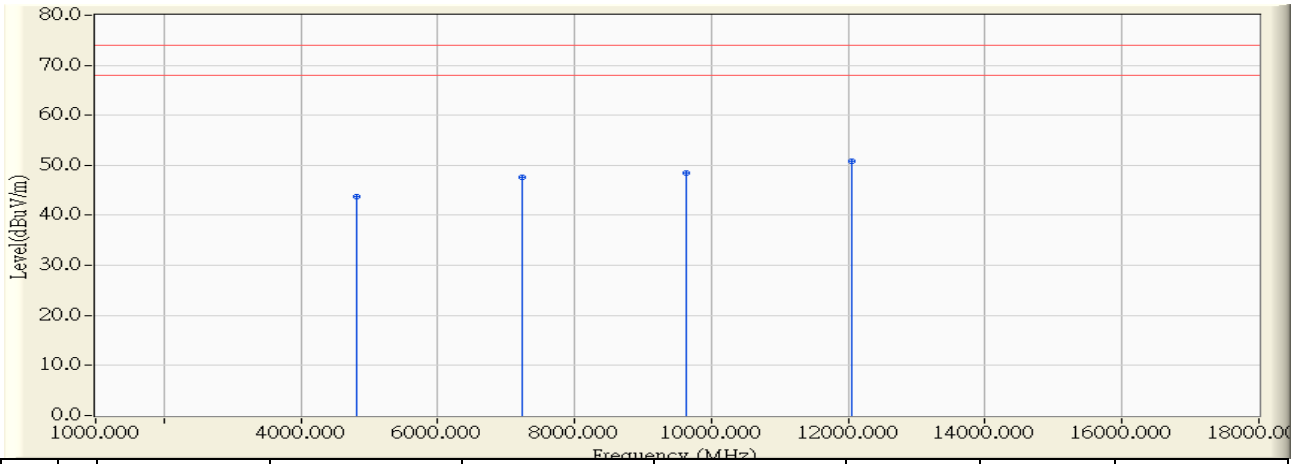

	Frequency (MHz)	Correct Factor (dB)	Reading Level (dBuV)	Measure Level (dBuV/m)	Margin (dB)	Limit (dBuV/m)	Detector Type
1	4823.852	-1.663	45.350	43.688	-30.312	74.000	PEAK
2	7238.303	5.431	42.180	47.610	-26.390	74.000	PEAK
3	9636.193	7.114	41.320	48.435	-25.565	74.000	PEAK
4	* 12059.590	9.914	40.850	50.764	-23.236	74.000	PEAK

Note:

1. All readings above 1GHz are performed with peak and/or average measurements as necessary.
2. “ * ”, means this data is the worst emission level.
3. Measurement Level = Reading Level + Correct Factor.
4. The average measurement was not performed when the peak measured data under the limit of average detection.
5. The Emission above 18GHz were not included because their levels is far less than the limit.

Site : CB1	Time : 2015/07/29 - 03:28
Limit : FCC_SpartC_15.247_H_03M_PK	Margin : 6
Probe : CB1_FCC_EFS_1-18G_H2 - HORIZONTAL	Power : AC 120 V / 60Hz
EUT : ASUS SRT-AC1900 Wireless Smart Router	Note : Mode 1: Tx- AUX Antenna (AD891M21) 802.11b_2437MHz

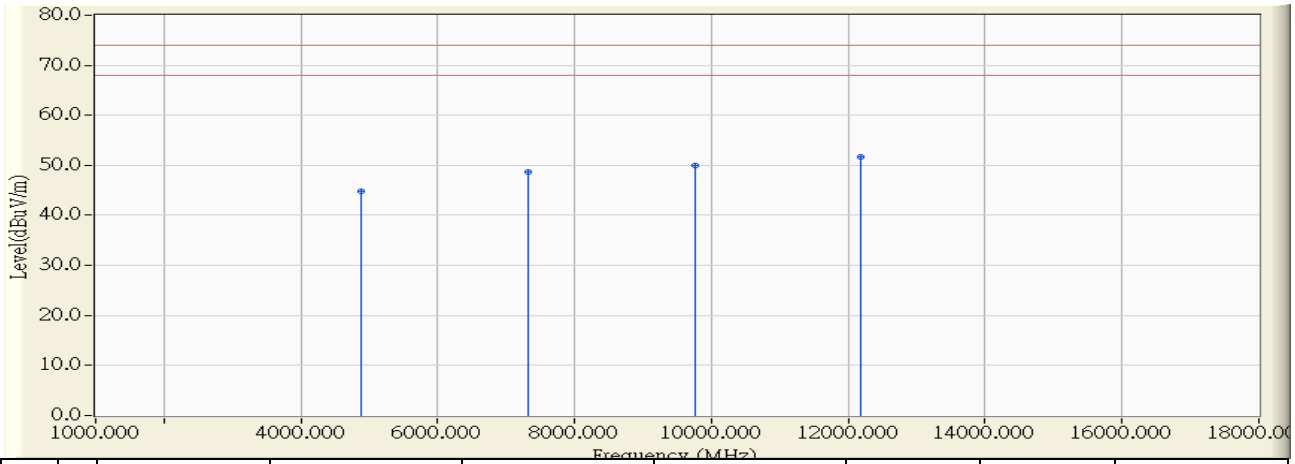

	Frequency (MHz)	Correct Factor (dB)	Reading Level (dBuV)	Measure Level (dBuV/m)	Margin (dB)	Limit (dBuV/m)	Detector Type
1	4873.880	-2.425	47.170	44.744	-29.256	74.000	PEAK
2	7313.447	6.078	42.700	48.778	-25.222	74.000	PEAK
3	9763.400	8.283	41.760	50.044	-23.956	74.000	PEAK
4	* 12186.199	10.187	41.430	51.617	-22.383	74.000	PEAK

Note:

1. All readings above 1GHz are performed with peak and/or average measurements as necessary.
2. “ * ”, means this data is the worst emission level.
3. Measurement Level = Reading Level + Correct Factor.
4. The average measurement was not performed when the peak measured data under the limit of average detection.
5. The Emission above 18GHz were not included because their levels is far less than the limit.

Site : CB1	Time : 2015/07/29 - 03:40
Limit : FCC_SpartC_15.247_H_03M_PK	Margin : 6
Probe : CB1_FCC_EFS_1-18G_H2 - VERTICAL	Power : AC 120 V / 60Hz
EUT : ASUS SRT-AC1900 Wireless Smart Router	Note : Mode 1: Tx- AUX Antenna (AD891M21) 802.11b_2437MHz

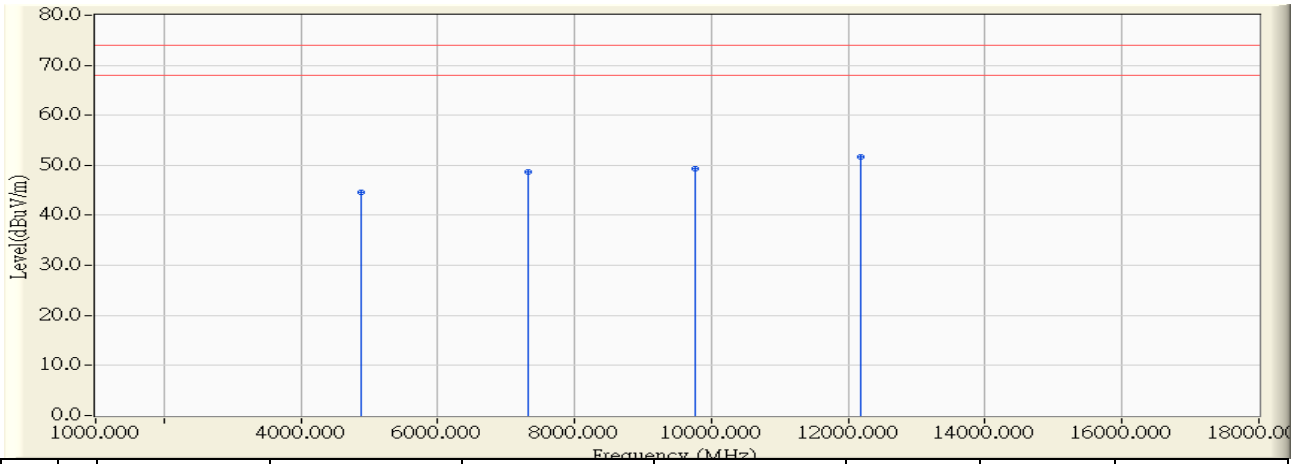

	Frequency (MHz)	Correct Factor (dB)	Reading Level (dBuV)	Measure Level (dBuV/m)	Margin (dB)	Limit (dBuV/m)	Detector Type
1	4874.000	-1.653	46.170	44.517	-29.483	74.000	PEAK
2	7309.720	5.571	43.140	48.711	-25.289	74.000	PEAK
3	9766.200	7.624	41.800	49.424	-24.576	74.000	PEAK
4	* 12183.220	9.891	41.740	51.631	-22.369	74.000	PEAK

Note:

1. All readings above 1GHz are performed with peak and/or average measurements as necessary.
2. “ * ”, means this data is the worst emission level.
3. Measurement Level = Reading Level + Correct Factor.
4. The average measurement was not performed when the peak measured data under the limit of average detection.
5. The Emission above 18GHz were not included because their levels is far less than the limit.

Site : CB1	Time : 2015/07/29 - 03:54
Limit : FCC_SpartC_15.247_H_03M_PK	Margin : 6
Probe : CB1_FCC_EFS_1-18G_H2 - HORIZONTAL	Power : AC 120 V / 60Hz
EUT : ASUS SRT-AC1900 Wireless Smart Router	Note : Mode 1: Tx- AUX Antenna (AD891M21) 802.11b_2462MHz

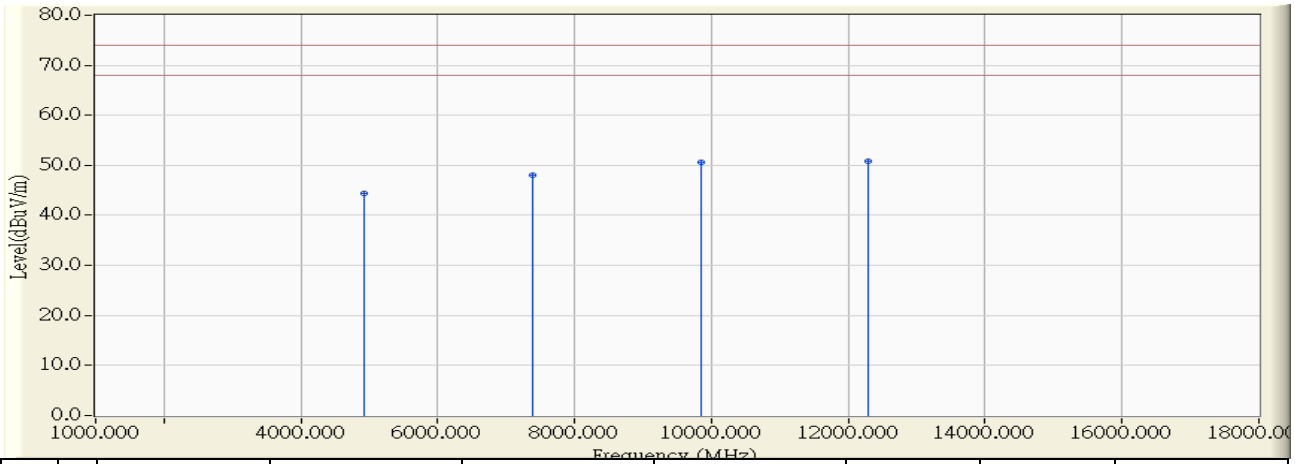

	Frequency (MHz)	Correct Factor (dB)	Reading Level (dBuV)	Measure Level (dBuV/m)	Margin (dB)	Limit (dBuV/m)	Detector Type
1	4924.200	-2.291	46.680	44.389	-29.611	74.000	PEAK
2	7380.000	6.210	41.830	48.039	-25.961	74.000	PEAK
3	9849.301	8.750	41.890	50.639	-23.361	74.000	PEAK
4	* 12294.005	10.058	40.700	50.758	-23.242	74.000	PEAK

Note:

1. All readings above 1GHz are performed with peak and/or average measurements as necessary.
2. “ * ”, means this data is the worst emission level.
3. Measurement Level = Reading Level + Correct Factor.
4. The average measurement was not performed when the peak measured data under the limit of average detection.
5. The Emission above 18GHz were not included because their levels is far less than the limit.

Site : CB1	Time : 2015/07/29 - 04:08
Limit : FCC_SpartC_15.247_H_03M_PK	Margin : 6
Probe : CB1_FCC_EFS_1-18G_H2 - VERTICAL	Power : AC 120 V / 60Hz
EUT : ASUS SRT-AC1900 Wireless Smart Router	Note : Mode 1: Tx- AUX Antenna (AD891M21) 802.11b_2462MHz

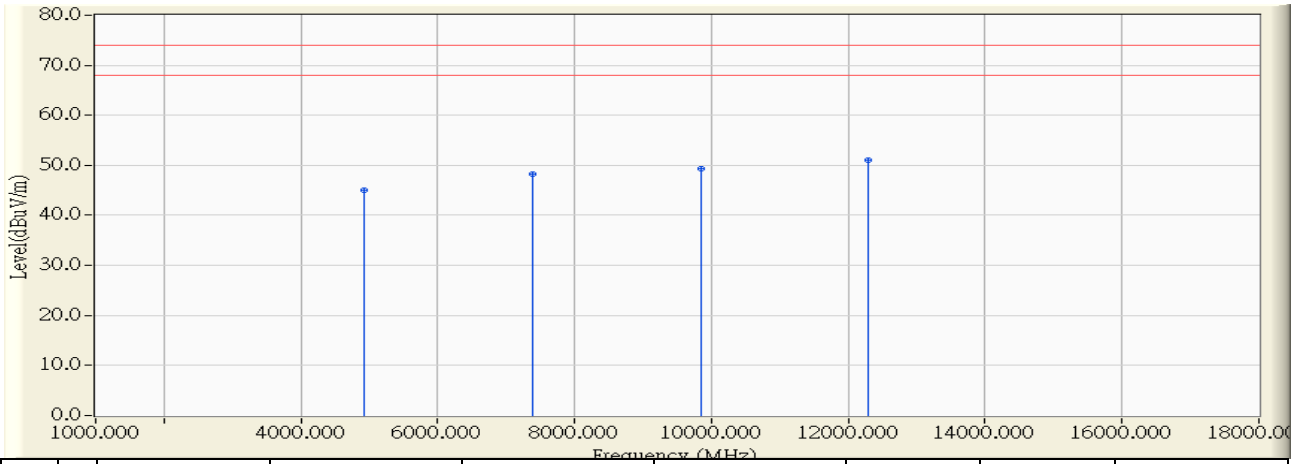

	Frequency (MHz)	Correct Factor (dB)	Reading Level (dBuV)	Measure Level (dBuV/m)	Margin (dB)	Limit (dBuV/m)	Detector Type
1	4924.060	-1.644	46.650	45.006	-28.994	74.000	PEAK
2	7384.991	5.720	42.530	48.249	-25.751	74.000	PEAK
3	9856.155	7.976	41.350	49.326	-24.674	74.000	PEAK
4	* 12290.300	9.870	41.150	51.020	-22.980	74.000	PEAK

Note:

1. All readings above 1GHz are performed with peak and/or average measurements as necessary.
2. “ * ”, means this data is the worst emission level.
3. Measurement Level = Reading Level + Correct Factor.
4. The average measurement was not performed when the peak measured data under the limit of average detection.
5. The Emission above 18GHz were not included because their levels is far less than the limit.

Site : CB1	Time : 2015/07/29 - 04:17
Limit : FCC_SpartC_15.247_H_03M_PK	Margin : 6
Probe : CB1_FCC_EFS_1-18G_H2 - HORIZONTAL	Power : AC 120 V / 60Hz
EUT : ASUS SRT-AC1900 Wireless Smart Router	Note : Mode 1: Tx- AUX Antenna (AD891M21) 802.11g_2412MHz

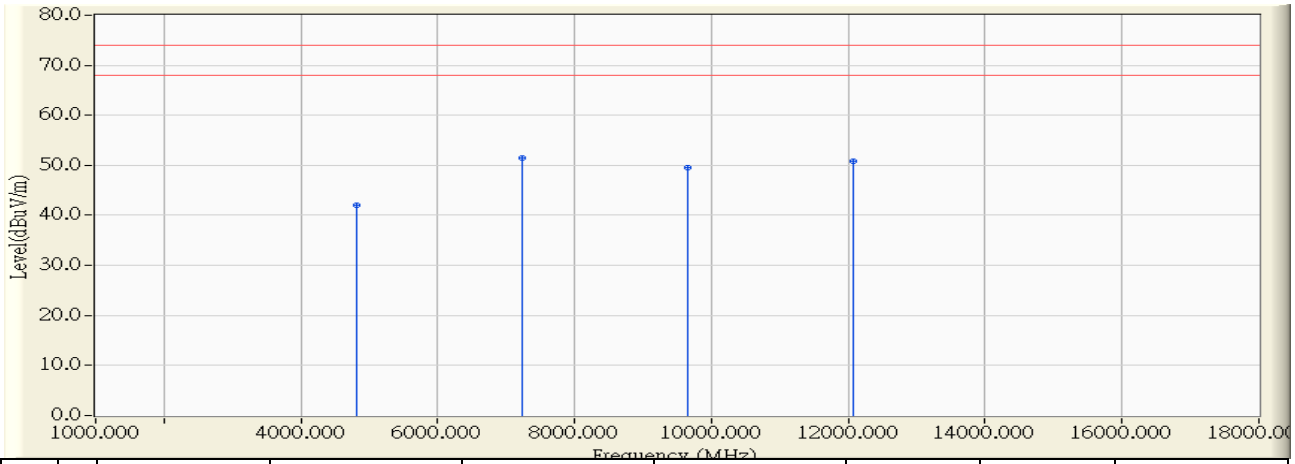

	Frequency (MHz)	Correct Factor (dB)	Reading Level (dBuV)	Measure Level (dBuV/m)	Margin (dB)	Limit (dBuV/m)	Detector Type
1	4823.940	-2.560	44.500	41.940	-32.060	74.000	PEAK
2	* 7227.296	5.909	45.620	51.529	-22.471	74.000	PEAK
3	9657.670	7.711	41.760	49.471	-24.529	74.000	PEAK
4	12064.370	10.332	40.550	50.882	-23.118	74.000	PEAK

Note:

1. All readings above 1GHz are performed with peak and/or average measurements as necessary.
2. “ * ”, means this data is the worst emission level.
3. Measurement Level = Reading Level + Correct Factor.
4. The average measurement was not performed when the peak measured data under the limit of average detection.
5. The Emission above 18GHz were not included because their levels is far less than the limit.

Site : CB1	Time : 2015/07/29 - 04:22
Limit : FCC_SpartC_15.247_H_03M_PK	Margin : 6
Probe : CB1_FCC_EFS_1-18G_H2 - VERTICAL	Power : AC 120 V / 60Hz
EUT : ASUS SRT-AC1900 Wireless Smart Router	Note : Mode 1: Tx- AUX Antenna (AD891M21) 802.11g_2412MHz

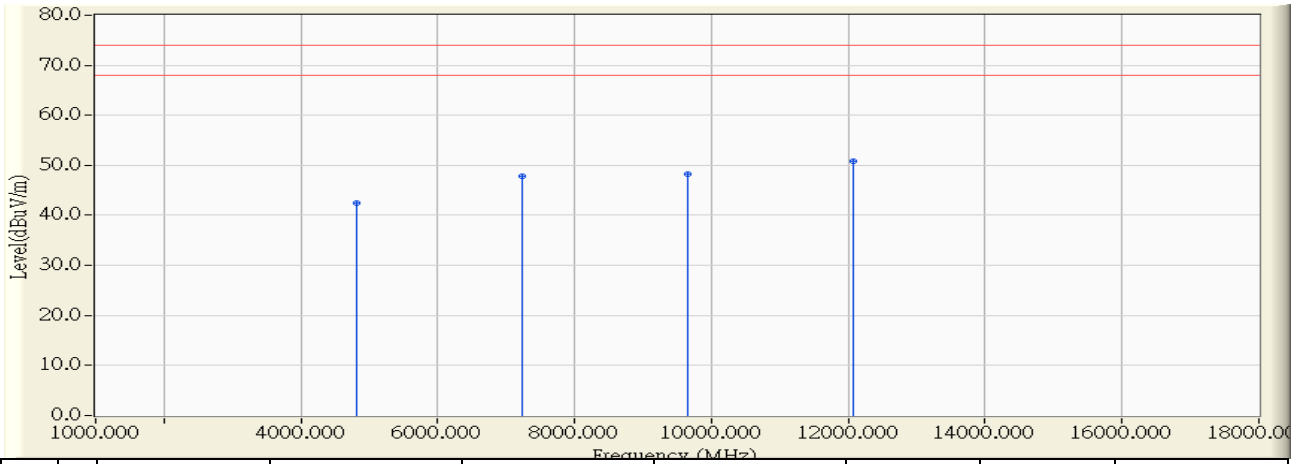

	Frequency (MHz)	Correct Factor (dB)	Reading Level (dBuV)	Measure Level (dBuV/m)	Margin (dB)	Limit (dBuV/m)	Detector Type
1	4821.600	-1.662	44.100	42.438	-31.562	74.000	PEAK
2	7231.870	5.418	42.400	47.818	-26.182	74.000	PEAK
3	9644.330	7.148	41.180	48.327	-25.673	74.000	PEAK
4	* 12064.978	9.913	41.020	50.933	-23.067	74.000	PEAK

Note:

1. All readings above 1GHz are performed with peak and/or average measurements as necessary.
2. “ * ”, means this data is the worst emission level.
3. Measurement Level = Reading Level + Correct Factor.
4. The average measurement was not performed when the peak measured data under the limit of average detection.
5. The Emission above 18GHz were not included because their levels is far less than the limit.

Site : CB1	Time : 2015/07/29 - 04:27
Limit : FCC_SpartC_15.247_H_03M_PK	Margin : 6
Probe : CB1_FCC_EFS_1-18G_H2 - HORIZONTAL	Power : AC 120 V / 60Hz
EUT : ASUS SRT-AC1900 Wireless Smart Router	Note : Mode 1: Tx- AUX Antenna (AD891M21) 802.11g_2437MHz

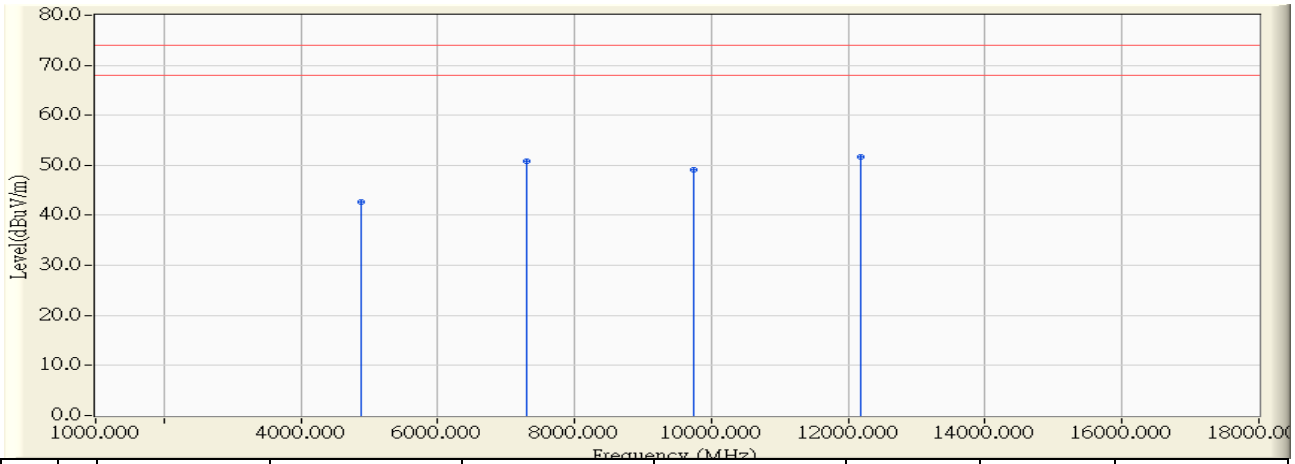

	Frequency (MHz)	Correct Factor (dB)	Reading Level (dBuV)	Measure Level (dBuV/m)	Margin (dB)	Limit (dBuV/m)	Detector Type
1	4872.800	-2.428	45.060	42.631	-31.369	74.000	PEAK
2	7306.600	6.064	44.730	50.795	-23.205	74.000	PEAK
3	9740.580	8.160	40.960	49.120	-24.880	74.000	PEAK
4	* 12188.920	10.184	41.410	51.594	-22.406	74.000	PEAK

Note:

1. All readings above 1GHz are performed with peak and/or average measurements as necessary.
2. “ * ”, means this data is the worst emission level.
3. Measurement Level = Reading Level + Correct Factor.
4. The average measurement was not performed when the peak measured data under the limit of average detection.
5. The Emission above 18GHz were not included because their levels is far less than the limit.

Site : CB1	Time : 2015/07/29 - 04:33
Limit : FCC_SpartC_15.247_H_03M_PK	Margin : 6
Probe : CB1_FCC_EFS_1-18G_H2 - VERTICAL	Power : AC 120 V / 60Hz
EUT : ASUS SRT-AC1900 Wireless Smart Router	Note : Mode 1: Tx- AUX Antenna (AD891M21) 802.11g_2437MHz

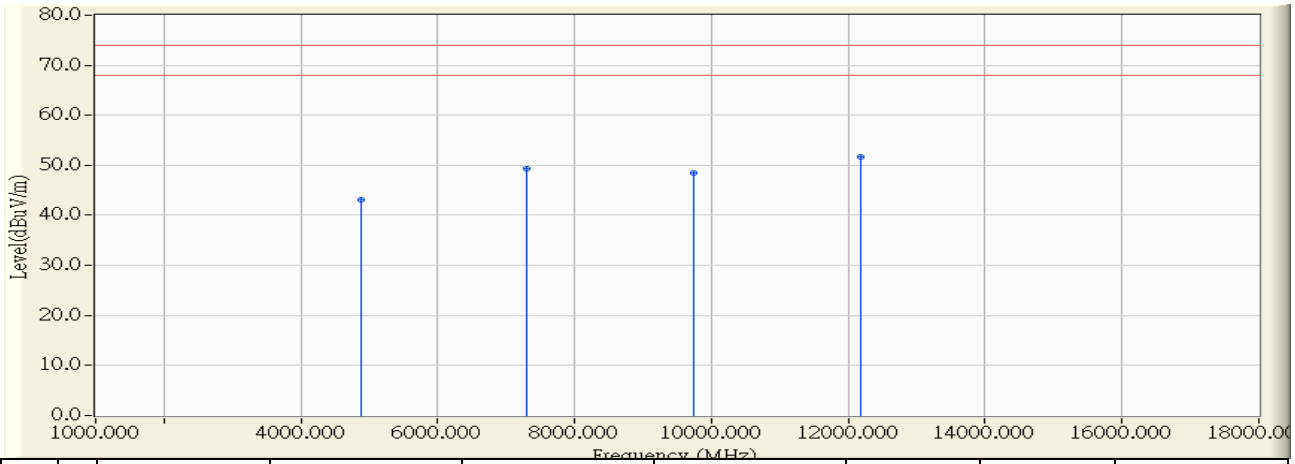

	Frequency (MHz)	Correct Factor (dB)	Reading Level (dBuV)	Measure Level (dBuV/m)	Margin (dB)	Limit (dBuV/m)	Detector Type
1	4874.570	-1.653	44.750	43.097	-30.903	74.000	PEAK
2	7303.400	5.559	43.790	49.349	-24.651	74.000	PEAK
3	9747.790	7.552	40.900	48.452	-25.548	74.000	PEAK
4	* 12178.010	9.891	41.810	51.702	-22.298	74.000	PEAK

Note:

1. All readings above 1GHz are performed with peak and/or average measurements as necessary.
2. “ * ”, means this data is the worst emission level.
3. Measurement Level = Reading Level + Correct Factor.
4. The average measurement was not performed when the peak measured data under the limit of average detection.
5. The Emission above 18GHz were not included because their levels is far less than the limit.

Site : CB1	Time : 2015/07/29 - 04:40
Limit : FCC_SpartC_15.247_H_03M_PK	Margin : 6
Probe : CB1_FCC_EFS_1-18G_H2 - HORIZONTAL	Power : AC 120 V / 60Hz
EUT : ASUS SRT-AC1900 Wireless Smart Router	Note : Mode 1: Tx- AUX Antenna (AD891M21) 802.11g_2462MHz

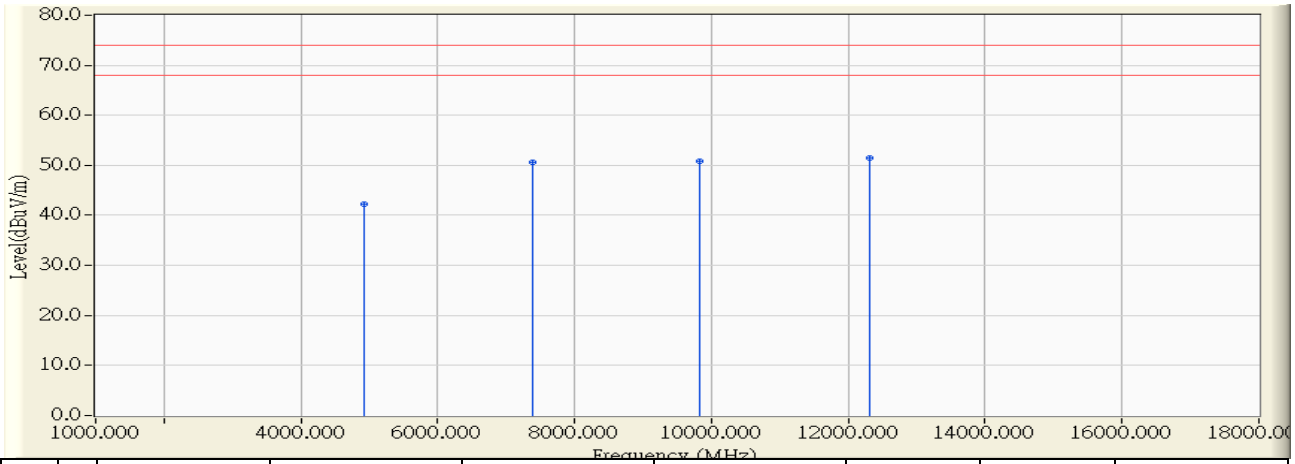

	Frequency (MHz)	Correct Factor (dB)	Reading Level (dBuV)	Measure Level (dBuV/m)	Margin (dB)	Limit (dBuV/m)	Detector Type
1	4924.030	-2.291	44.550	42.259	-31.741	74.000	PEAK
2	7390.250	6.230	44.430	50.659	-23.341	74.000	PEAK
3	9830.780	8.649	42.190	50.839	-23.161	74.000	PEAK
4	* 12303.960	10.046	41.400	51.446	-22.554	74.000	PEAK

Note:

1. All readings above 1GHz are performed with peak and/or average measurements as necessary.
2. “ * ”, means this data is the worst emission level.
3. Measurement Level = Reading Level + Correct Factor.
4. The average measurement was not performed when the peak measured data under the limit of average detection.
5. The Emission above 18GHz were not included because their levels is far less than the limit.

Site : CB1	Time : 2015/07/29 - 04:46
Limit : FCC_SpartC_15.247_H_03M_PK	Margin : 6
Probe : CB1_FCC_EFS_1-18G_H2 - VERTICAL	Power : AC 120 V / 60Hz
EUT : ASUS SRT-AC1900 Wireless Smart Router	Note : Mode 1: Tx- AUX Antenna (AD891M21) 802.11g_2462MHz

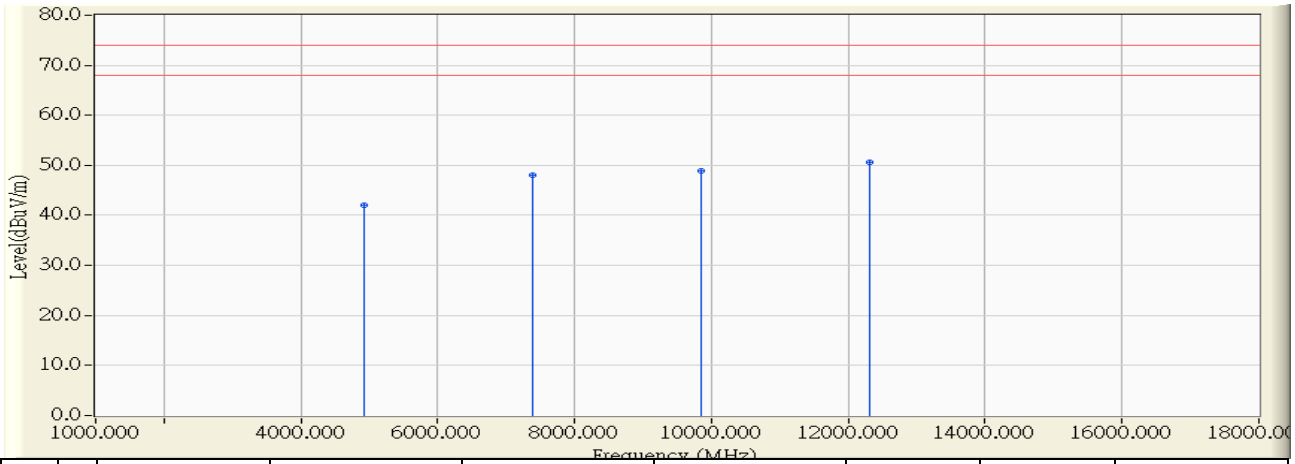

	Frequency (MHz)	Correct Factor (dB)	Reading Level (dBuV)	Measure Level (dBuV/m)	Margin (dB)	Limit (dBuV/m)	Detector Type
1	4926.230	-1.643	43.650	42.007	-31.993	74.000	PEAK
2	7392.759	5.735	42.400	48.134	-25.866	74.000	PEAK
3	9859.099	7.987	40.990	48.978	-25.022	74.000	PEAK
4	* 12301.812	9.868	40.810	50.678	-23.322	74.000	PEAK

Note:

1. All readings above 1GHz are performed with peak and/or average measurements as necessary.
2. “ * ”, means this data is the worst emission level.
3. Measurement Level = Reading Level + Correct Factor.
4. The average measurement was not performed when the peak measured data under the limit of average detection.
5. The Emission above 18GHz were not included because their levels is far less than the limit.

Site : CB1	Time : 2015/07/29 - 04:54
Limit : FCC_SpartC_15.247_H_03M_PK	Margin : 6
Probe : CB1_FCC_EFS_1-18G_H2 - HORIZONTAL	Power : AC 120 V / 60Hz
EUT : ASUS SRT-AC1900 Wireless Smart Router	Note : Mode 1: Tx- AUX Antenna (AD891M21) 802.11n(20MHz)_2412MHz

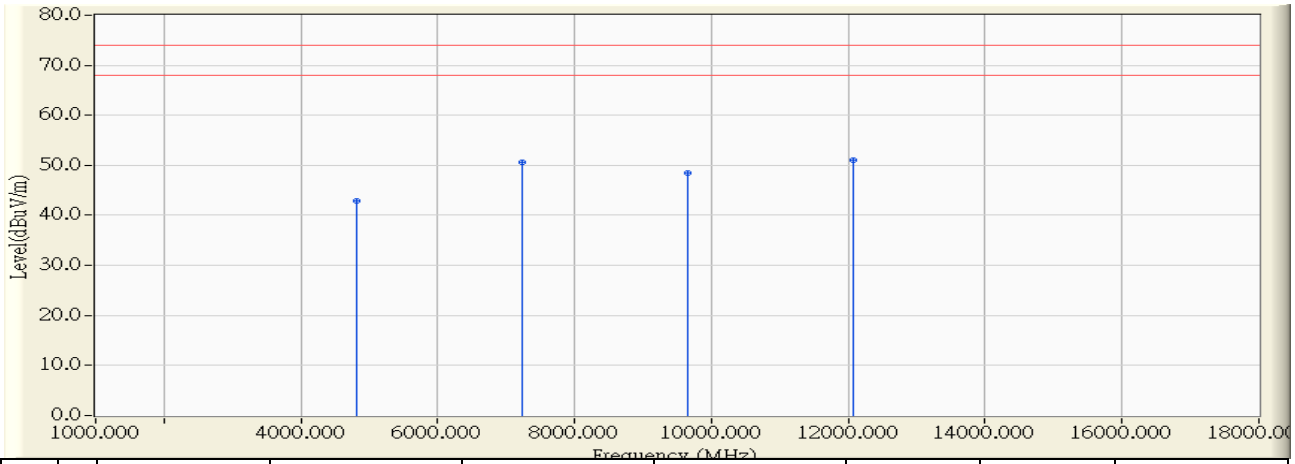

	Frequency (MHz)	Correct Factor (dB)	Reading Level (dBuV)	Measure Level (dBuV/m)	Margin (dB)	Limit (dBuV/m)	Detector Type
1	4822.830	-2.562	45.450	42.887	-31.113	74.000	PEAK
2	7242.600	5.939	44.600	50.539	-23.461	74.000	PEAK
3	9645.420	7.645	40.890	48.535	-25.465	74.000	PEAK
4	* 12063.670	10.334	40.800	51.133	-22.867	74.000	PEAK

Note:

1. All readings above 1GHz are performed with peak and/or average measurements as necessary.
2. “ * ”, means this data is the worst emission level.
3. Measurement Level = Reading Level + Correct Factor.
4. The average measurement was not performed when the peak measured data under the limit of average detection.
5. The Emission above 18GHz were not included because their levels is far less than the limit.

Site : CB1	Time : 2015/07/29 - 04:55
Limit : FCC_SpartC_15.247_H_03M_PK	Margin : 6
Probe : CB1_FCC_EFS_1-18G_H2 - VERTICAL	Power : AC 120 V / 60Hz
EUT : ASUS SRT-AC1900 Wireless Smart Router	Note : Mode 1: Tx- AUX Antenna (AD891M21) 802.11n(20MHz)_2412MHz

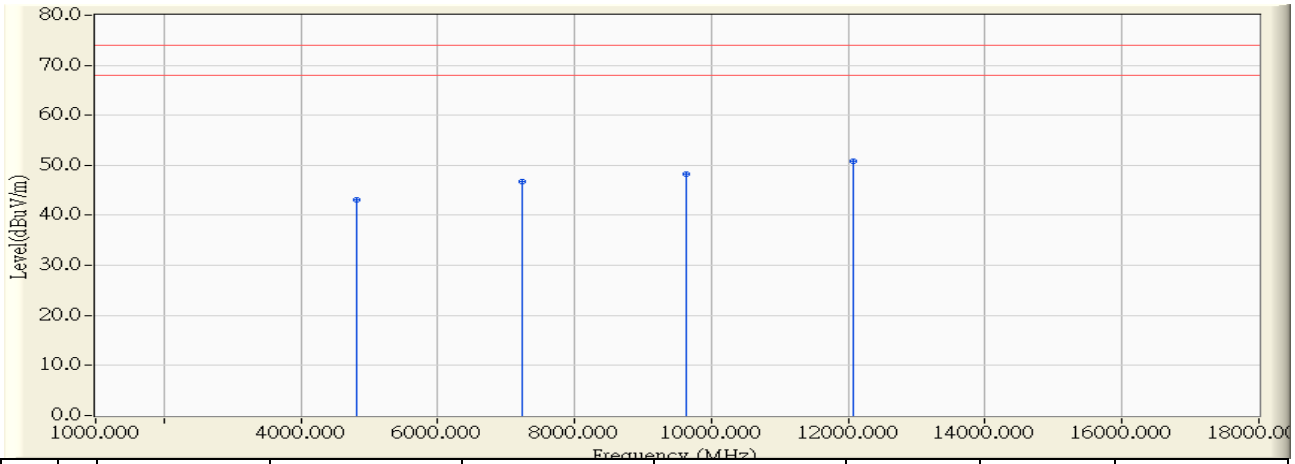

	Frequency (MHz)	Correct Factor (dB)	Reading Level (dBuV)	Measure Level (dBuV/m)	Margin (dB)	Limit (dBuV/m)	Detector Type
1	4819.680	-1.663	44.730	43.067	-30.933	74.000	PEAK
2	7224.413	5.404	41.400	46.803	-27.197	74.000	PEAK
3	9637.150	7.119	41.060	48.179	-25.821	74.000	PEAK
4	* 12070.830	9.912	40.830	50.742	-23.258	74.000	PEAK

Note:

1. All readings above 1GHz are performed with peak and/or average measurements as necessary.
2. “ * ”, means this data is the worst emission level.
3. Measurement Level = Reading Level + Correct Factor.
4. The average measurement was not performed when the peak measured data under the limit of average detection.
5. The Emission above 18GHz were not included because their levels is far less than the limit.

Site : CB1	Time : 2015/07/29 - 05:19
Limit : FCC_SpartC_15.247_H_03M_PK	Margin : 6
Probe : CB1_FCC_EFS_1-18G_H2 - HORIZONTAL	Power : AC 120 V / 60Hz
EUT : ASUS SRT-AC1900 Wireless Smart Router	Note : Mode 1: Tx- AUX Antenna (AD891M21) 802.11n(20MHz)_2437MHz

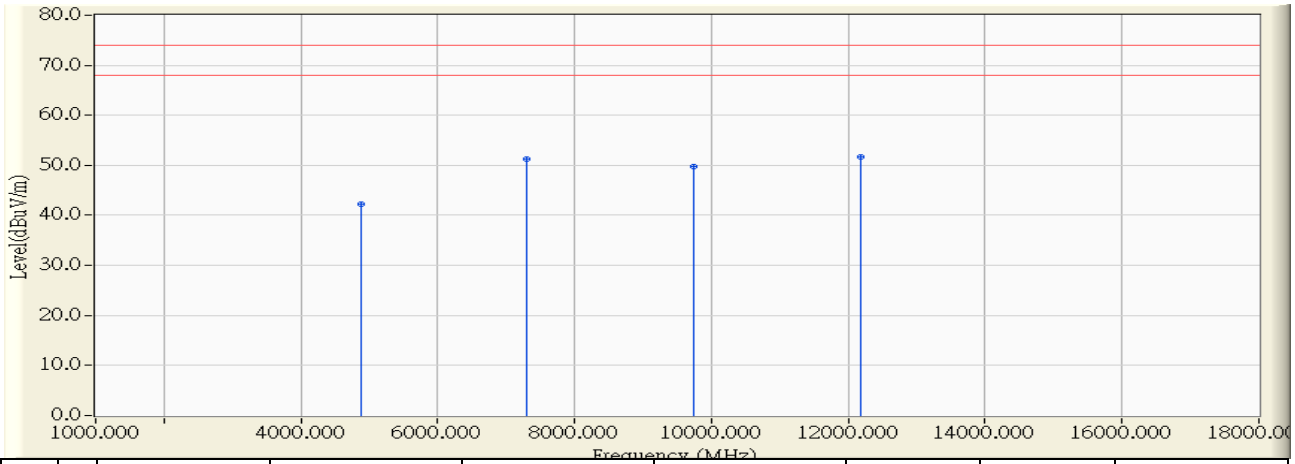

	Frequency (MHz)	Correct Factor (dB)	Reading Level (dBuV)	Measure Level (dBuV/m)	Margin (dB)	Limit (dBuV/m)	Detector Type
1	4869.053	-2.439	44.750	42.311	-31.689	74.000	PEAK
2	7307.480	6.066	45.270	51.337	-22.663	74.000	PEAK
3	9740.590	8.160	41.530	49.690	-24.310	74.000	PEAK
4	* 12189.000	10.184	41.470	51.653	-22.347	74.000	PEAK

Note:

1. All readings above 1GHz are performed with peak and/or average measurements as necessary.
2. “ * ”, means this data is the worst emission level.
3. Measurement Level = Reading Level + Correct Factor.
4. The average measurement was not performed when the peak measured data under the limit of average detection.
5. The Emission above 18GHz were not included because their levels is far less than the limit.

Site : CB1	Time : 2015/07/29 - 05:20
Limit : FCC_SpartC_15.247_H_03M_PK	Margin : 6
Probe : CB1_FCC_EFS_1-18G_H2 - VERTICAL	Power : AC 120 V / 60Hz
EUT : ASUS SRT-AC1900 Wireless Smart Router	Note : Mode 1: Tx- AUX Antenna (AD891M21) 802.11n(20MHz)_2437MHz

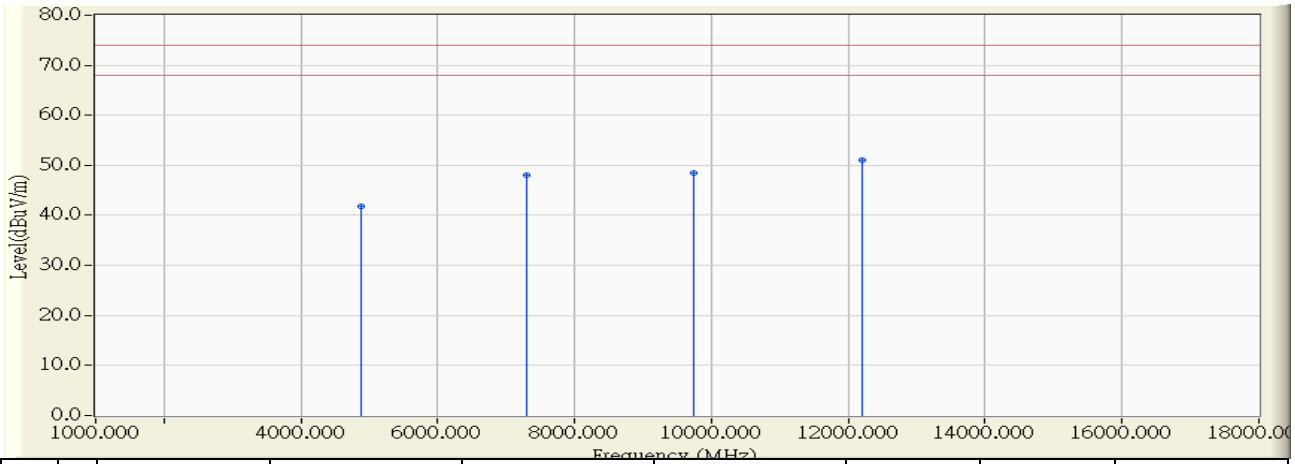

	Frequency (MHz)	Correct Factor (dB)	Reading Level (dBuV)	Measure Level (dBuV/m)	Margin (dB)	Limit (dBuV/m)	Detector Type
1	4881.290	-1.651	43.490	41.838	-32.162	74.000	PEAK
2	7304.800	5.562	42.390	47.951	-26.049	74.000	PEAK
3	9743.770	7.536	40.930	48.466	-25.534	74.000	PEAK
4	* 12197.780	9.888	41.080	50.968	-23.032	74.000	PEAK

Note:

1. All readings above 1GHz are performed with peak and/or average measurements as necessary.
2. “ * ”, means this data is the worst emission level.
3. Measurement Level = Reading Level + Correct Factor.
4. The average measurement was not performed when the peak measured data under the limit of average detection.
5. The Emission above 18GHz were not included because their levels is far less than the limit.

Site : CB1	Time : 2015/07/29 - 05:22
Limit : FCC_SpartC_15.247_H_03M_PK	Margin : 6
Probe : CB1_FCC_EFS_1-18G_H2 - HORIZONTAL	Power : AC 120 V / 60Hz
EUT : ASUS SRT-AC1900 Wireless Smart Router	Note : Mode 1: Tx- AUX Antenna (AD891M21) 802.11n(20MHz)_2462MHz

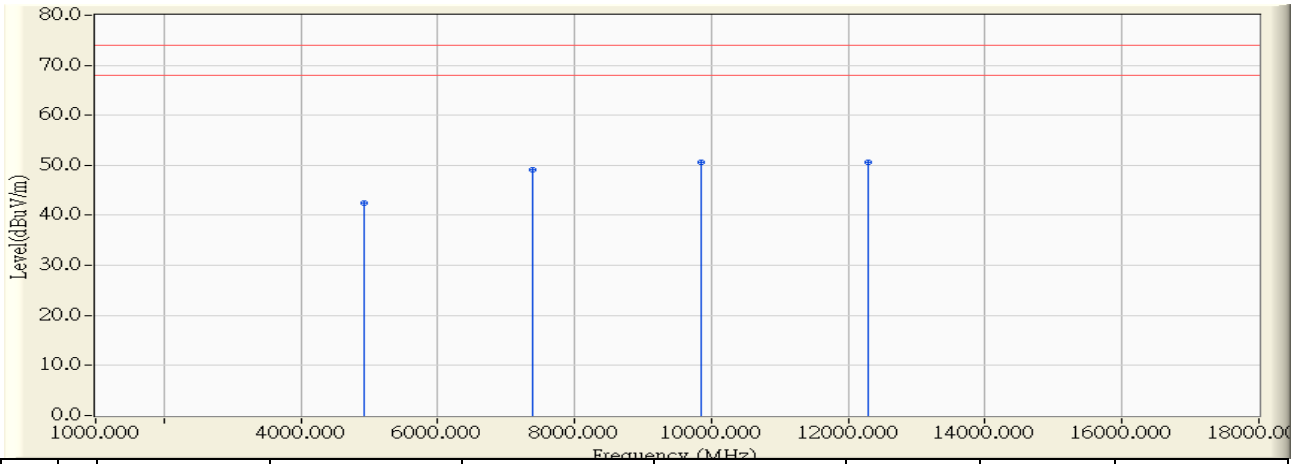

	Frequency (MHz)	Correct Factor (dB)	Reading Level (dBuV)	Measure Level (dBuV/m)	Margin (dB)	Limit (dBuV/m)	Detector Type
1	4919.090	-2.305	44.750	42.446	-31.554	74.000	PEAK
2	7390.220	6.229	42.870	49.099	-24.901	74.000	PEAK
3	* 9852.400	8.766	41.840	50.606	-23.394	74.000	PEAK
4	12294.010	10.058	40.540	50.598	-23.402	74.000	PEAK

Note:

1. All readings above 1GHz are performed with peak and/or average measurements as necessary.
2. “ * ”, means this data is the worst emission level.
3. Measurement Level = Reading Level + Correct Factor.
4. The average measurement was not performed when the peak measured data under the limit of average detection.
5. The Emission above 18GHz were not included because their levels is far less than the limit.

Site : CB1	Time : 2015/07/29 - 05:23
Limit : FCC_SpartC_15.247_H_03M_PK	Margin : 6
Probe : CB1_FCC_EFS_1-18G_H2 - VERTICAL	Power : AC 120 V / 60Hz
EUT : ASUS SRT-AC1900 Wireless Smart Router	Note : Mode 1: Tx- AUX Antenna (AD891M21) 802.11n(20MHz)_2462MHz

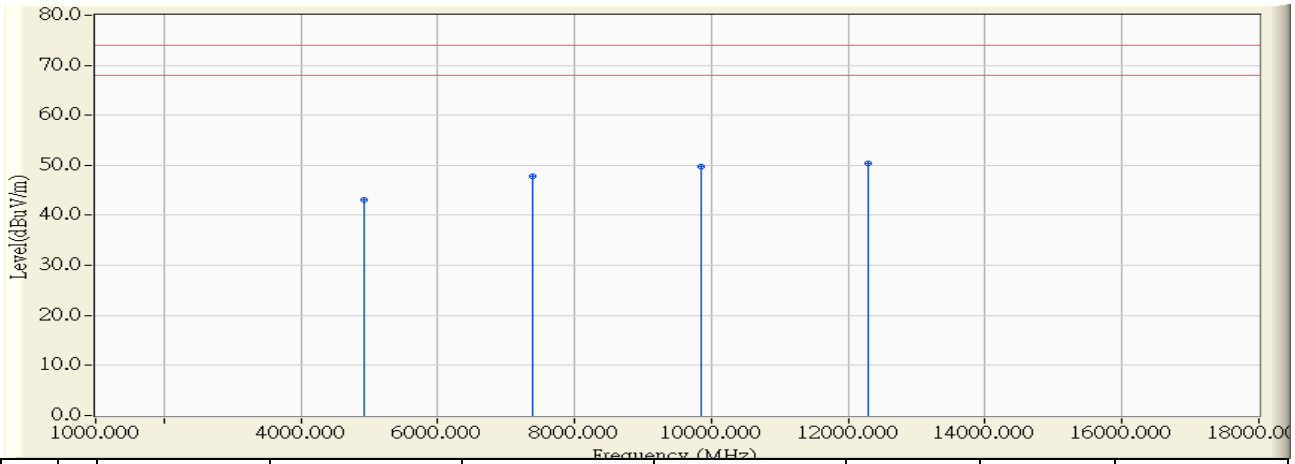

	Frequency (MHz)	Correct Factor (dB)	Reading Level (dBuV)	Measure Level (dBuV/m)	Margin (dB)	Limit (dBuV/m)	Detector Type
1	4927.520	-1.643	44.710	43.067	-30.933	74.000	PEAK
2	7387.240	5.723	42.090	47.814	-26.186	74.000	PEAK
3	9841.390	7.918	41.830	49.748	-24.252	74.000	PEAK
4	* 12293.800	9.869	40.500	50.369	-23.631	74.000	PEAK

Note:

1. All readings above 1GHz are performed with peak and/or average measurements as necessary.
2. “ * ”, means this data is the worst emission level.
3. Measurement Level = Reading Level + Correct Factor.
4. The average measurement was not performed when the peak measured data under the limit of average detection.
5. The Emission above 18GHz were not included because their levels is far less than the limit.

Site : CB1	Time : 2015/07/29 - 20:50
Limit : FCC_SpartC_15.247_H_03M_PK	Margin : 6
Probe : CB1_FCC_EFS_1-18G_H2 - HORIZONTAL	Power : AC 120 V / 60Hz
EUT : ASUS SRT-AC1900 Wireless Smart Router	Note : Mode 1: Tx- AUX Antenna (AD891M21) 802.11n(40MHz)_2422MHz

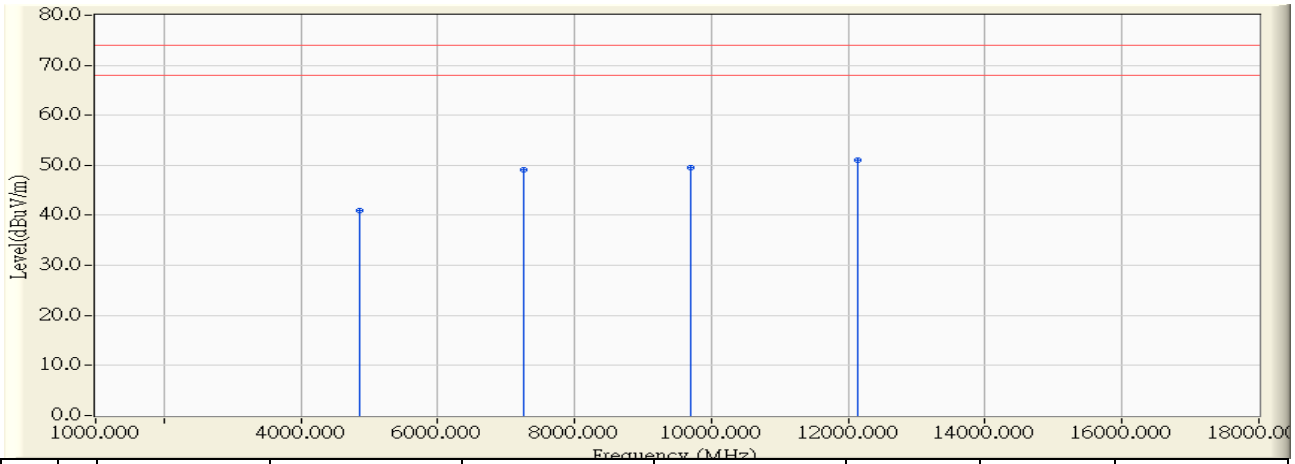

	Frequency (MHz)	Correct Factor (dB)	Reading Level (dBuV)	Measure Level (dBuV/m)	Margin (dB)	Limit (dBuV/m)	Detector Type
1	4864.260	-2.452	43.440	40.989	-33.011	74.000	PEAK
2	7246.850	5.947	43.270	49.217	-24.783	74.000	PEAK
3	9686.790	7.869	41.580	49.449	-24.551	74.000	PEAK
4	* 12129.950	10.254	40.880	51.134	-22.866	74.000	PEAK

Note:

1. All readings above 1GHz are performed with peak and/or average measurements as necessary.
2. “ * ”, means this data is the worst emission level.
3. Measurement Level = Reading Level + Correct Factor.
4. The average measurement was not performed when the peak measured data under the limit of average detection.
5. The Emission above 18GHz were not included because their levels is far less than the limit.

Site : CB1	Time : 2015/07/29 - 21:02
Limit : FCC_SpartC_15.247_H_03M_PK	Margin : 6
Probe : CB1_FCC_EFS_1-18G_H2 - VERTICAL	Power : AC 120 V / 60Hz
EUT : ASUS SRT-AC1900 Wireless Smart Router	Note : Mode 1: Tx- AUX Antenna (AD891M21) 802.11n(40MHz)_2422MHz

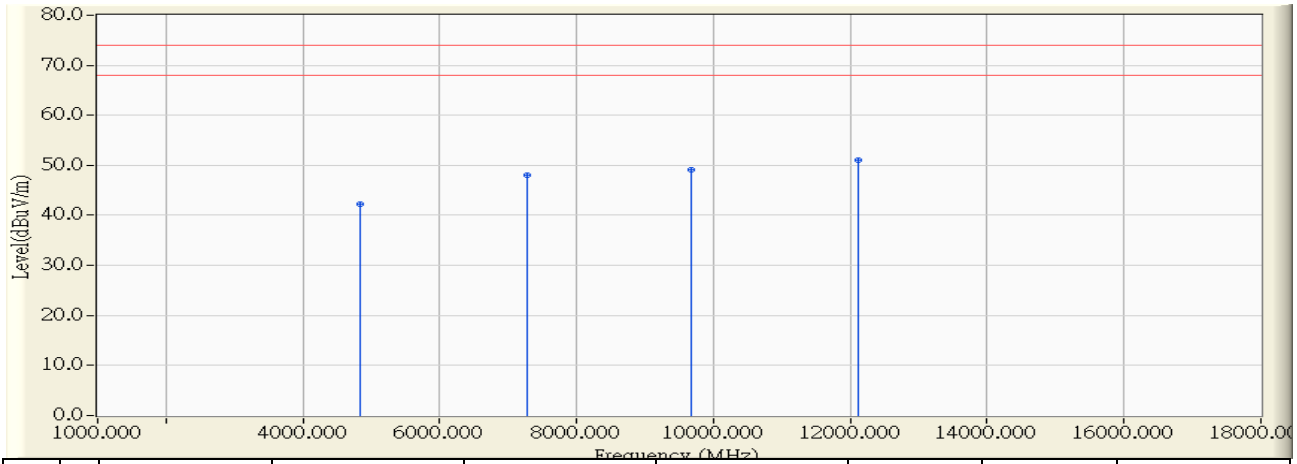

	Frequency (MHz)	Correct Factor (dB)	Reading Level (dBuV)	Measure Level (dBuV/m)	Margin (dB)	Limit (dBuV/m)	Detector Type
1	4844.225	-1.659	43.950	42.292	-31.708	74.000	PEAK
2	7273.749	5.500	42.610	48.110	-25.890	74.000	PEAK
3	9669.836	7.247	41.820	49.067	-24.933	74.000	PEAK
4	* 12108.965	9.905	41.040	50.945	-23.055	74.000	PEAK

Note:

1. All readings above 1GHz are performed with peak and/or average measurements as necessary.
2. “ * ”, means this data is the worst emission level.
3. Measurement Level = Reading Level + Correct Factor.
4. The average measurement was not performed when the peak measured data under the limit of average detection.
5. The Emission above 18GHz were not included because their levels is far less than the limit.

Site : CB1	Time : 2015/07/29 - 21:31
Limit : FCC_SpartC_15.247_H_03M_PK	Margin : 6
Probe : CB1_FCC_EFS_1-18G_H2 - HORIZONTAL	Power : AC 120 V / 60Hz
EUT : ASUS SRT-AC1900 Wireless Smart Router	Note : Mode 1: Tx- AUX Antenna (AD891M21) 802.11n(40MHz)_2437MHz

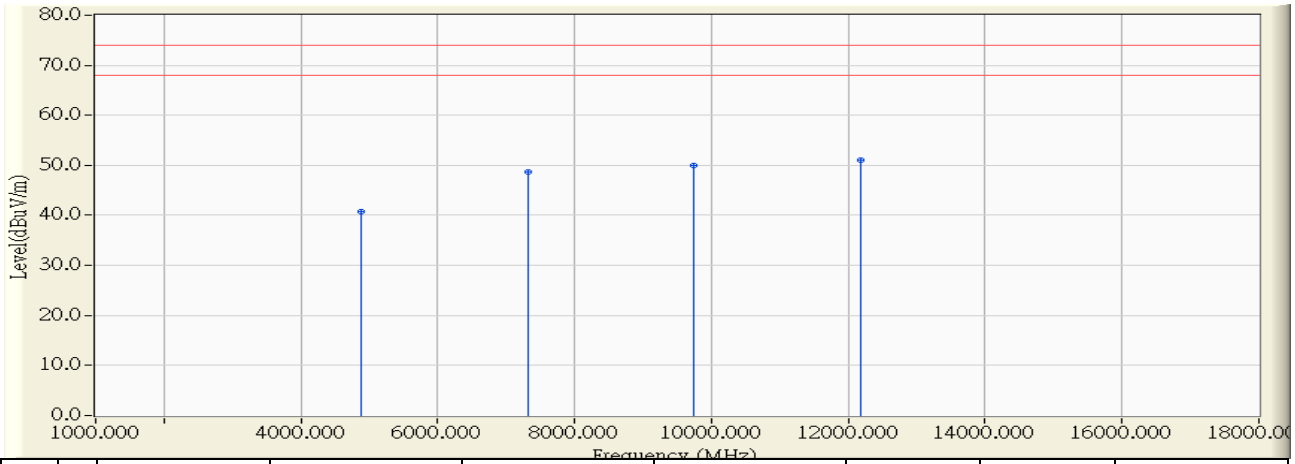

	Frequency (MHz)	Correct Factor (dB)	Reading Level (dBuV)	Measure Level (dBuV/m)	Margin (dB)	Limit (dBuV/m)	Detector Type
1	4887.360	-2.389	43.220	40.830	-33.170	74.000	PEAK
2	7320.360	6.093	42.510	48.602	-25.398	74.000	PEAK
3	9750.172	8.212	41.680	49.892	-24.108	74.000	PEAK
4	* 12190.850	10.181	40.910	51.091	-22.909	74.000	PEAK

Note:

1. All readings above 1GHz are performed with peak and/or average measurements as necessary.
2. “ * ”, means this data is the worst emission level.
3. Measurement Level = Reading Level + Correct Factor.
4. The average measurement was not performed when the peak measured data under the limit of average detection.
5. The Emission above 18GHz were not included because their levels is far less than the limit.

Site : CB1	Time : 2015/07/29 - 21:40
Limit : FCC_SpartC_15.247_H_03M_PK	Margin : 6
Probe : CB1_FCC_EFS_1-18G_H2 - VERTICAL	Power : AC 120 V / 60Hz
EUT : ASUS SRT-AC1900 Wireless Smart Router	Note : Mode 1: Tx- AUX Antenna (AD891M21) 802.11n(40MHz)_2437MHz

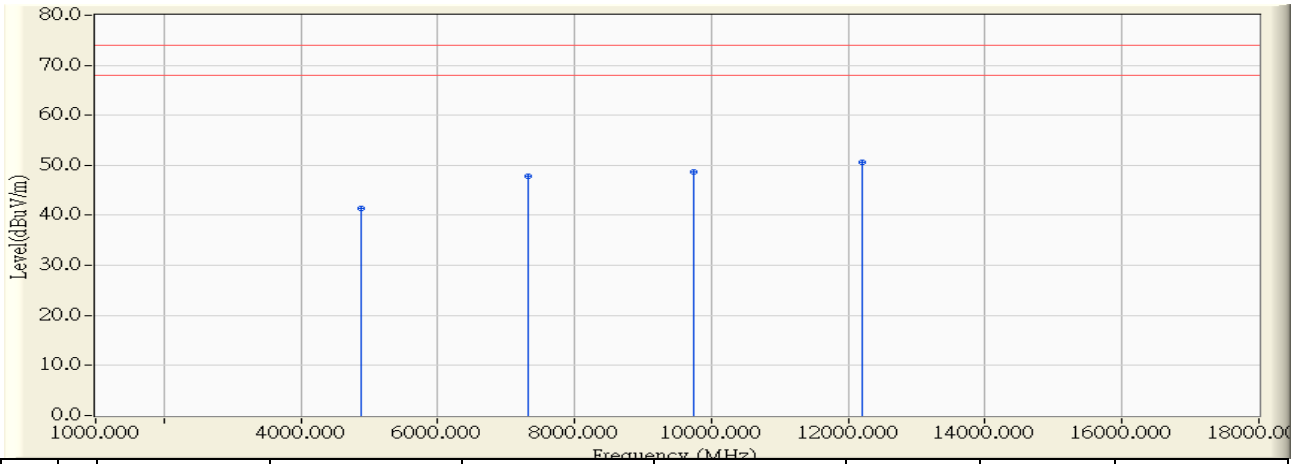

	Frequency (MHz)	Correct Factor (dB)	Reading Level (dBuV)	Measure Level (dBuV/m)	Margin (dB)	Limit (dBuV/m)	Detector Type
1	4878.730	-1.652	43.030	41.378	-32.622	74.000	PEAK
2	7317.040	5.585	42.240	47.825	-26.175	74.000	PEAK
3	9730.600	7.485	41.200	48.685	-25.315	74.000	PEAK
4	* 12198.830	9.888	40.640	50.528	-23.472	74.000	PEAK

Note:

1. All readings above 1GHz are performed with peak and/or average measurements as necessary.
2. “ * ”, means this data is the worst emission level.
3. Measurement Level = Reading Level + Correct Factor.
4. The average measurement was not performed when the peak measured data under the limit of average detection.
5. The Emission above 18GHz were not included because their levels is far less than the limit.

Site : CB1	Time : 2015/07/29 - 21:55
Limit : FCC_SpartC_15.247_H_03M_PK	Margin : 6
Probe : CB1_FCC_EFS_1-18G_H2 - HORIZONTAL	Power : AC 120 V / 60Hz
EUT : ASUS SRT-AC1900 Wireless Smart Router	Note : Mode 1: Tx- AUX Antenna (AD891M21) 802.11n(40MHz)_2452MHz

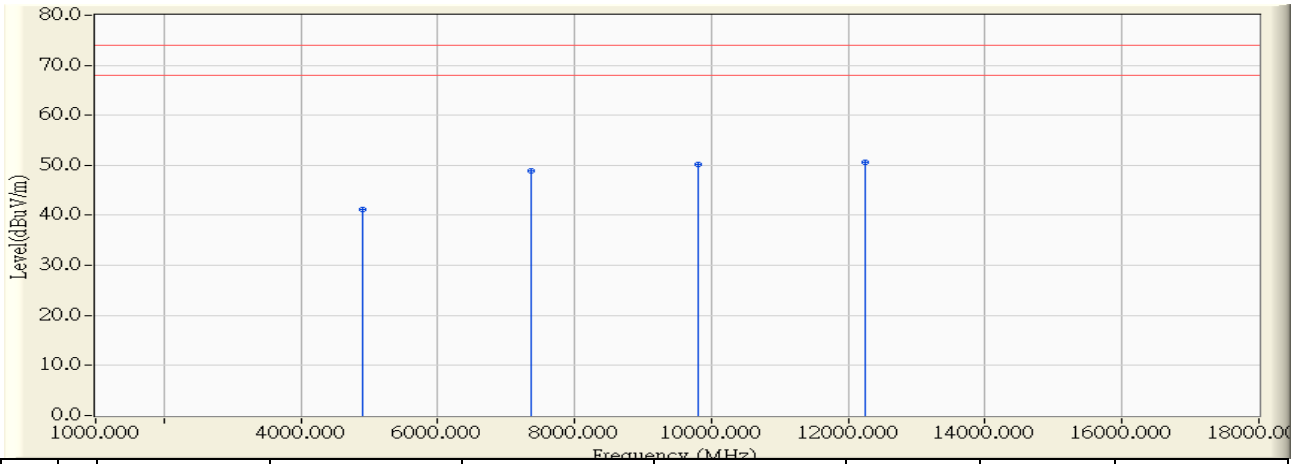

	Frequency (MHz)	Correct Factor (dB)	Reading Level (dBuV)	Measure Level (dBuV/m)	Margin (dB)	Limit (dBuV/m)	Detector Type
1	4896.330	-2.365	43.530	41.165	-32.835	74.000	PEAK
2	7362.129	6.174	42.790	48.964	-25.036	74.000	PEAK
3	9806.414	8.516	41.740	50.257	-23.743	74.000	PEAK
4	* 12242.520	10.120	40.520	50.640	-23.360	74.000	PEAK

Note:

1. All readings above 1GHz are performed with peak and/or average measurements as necessary.
2. “ * ”, means this data is the worst emission level.
3. Measurement Level = Reading Level + Correct Factor.
4. The average measurement was not performed when the peak measured data under the limit of average detection.
5. The Emission above 18GHz were not included because their levels is far less than the limit.

Site : CB1	Time : 2015/07/29 - 22:02
Limit : FCC_SpartC_15.247_H_03M_PK	Margin : 6
Probe : CB1_FCC_EFS_1-18G_H2 - VERTICAL	Power : AC 120 V / 60Hz
EUT : ASUS SRT-AC1900 Wireless Smart Router	Note : Mode 1: Tx- AUX Antenna (AD891M21) 802.11n(40MHz)_2452MHz

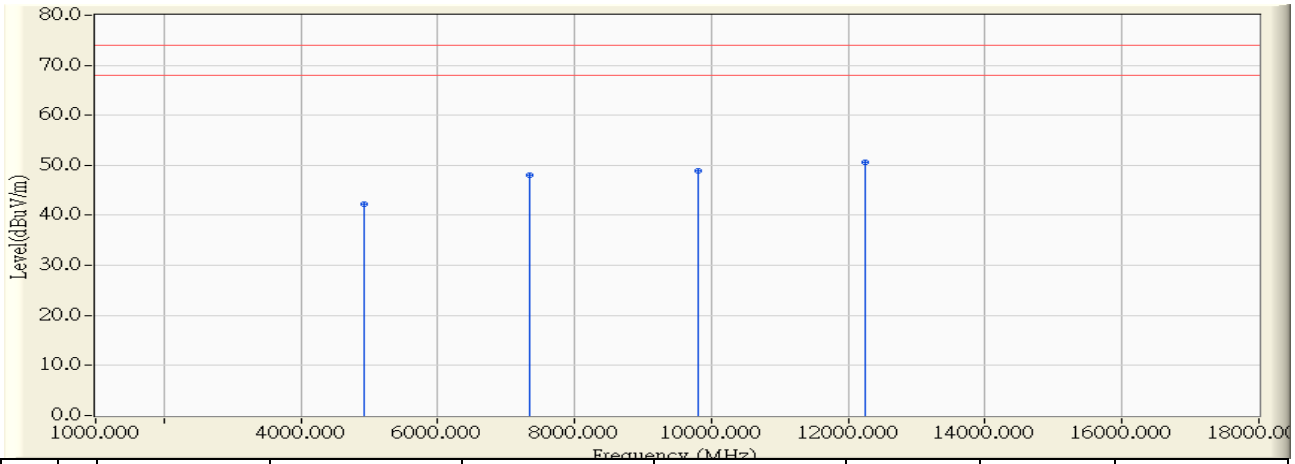

	Frequency (MHz)	Correct Factor (dB)	Reading Level (dBuV)	Measure Level (dBuV/m)	Margin (dB)	Limit (dBuV/m)	Detector Type
1	4915.080	-1.645	43.890	42.245	-31.755	74.000	PEAK
2	7351.640	5.653	42.330	47.983	-26.017	74.000	PEAK
3	9807.810	7.787	41.200	48.987	-25.013	74.000	PEAK
4	* 12246.515	9.879	40.830	50.708	-23.292	74.000	PEAK

Note:

1. All readings above 1GHz are performed with peak and/or average measurements as necessary.
2. “ * ”, means this data is the worst emission level.
3. Measurement Level = Reading Level + Correct Factor.
4. The average measurement was not performed when the peak measured data under the limit of average detection.
5. The Emission above 18GHz were not included because their levels is far less than the limit.

5. RF antenna conducted test

5.1. Test Equipment

The following test equipments are used during the test:

RF antenna conducted test / SR7

Instrument	Manufacturer	Model No.	Serial No	Next Cal. Date
Spectrum Analyzer	Agilent	N9010A-EXA	US47140172	2016/07/13

Note: 1. All equipments that need to calibrate are with calibration period of 1 year.

5.2. Test Setup

RF Antenna Conducted Measurement:

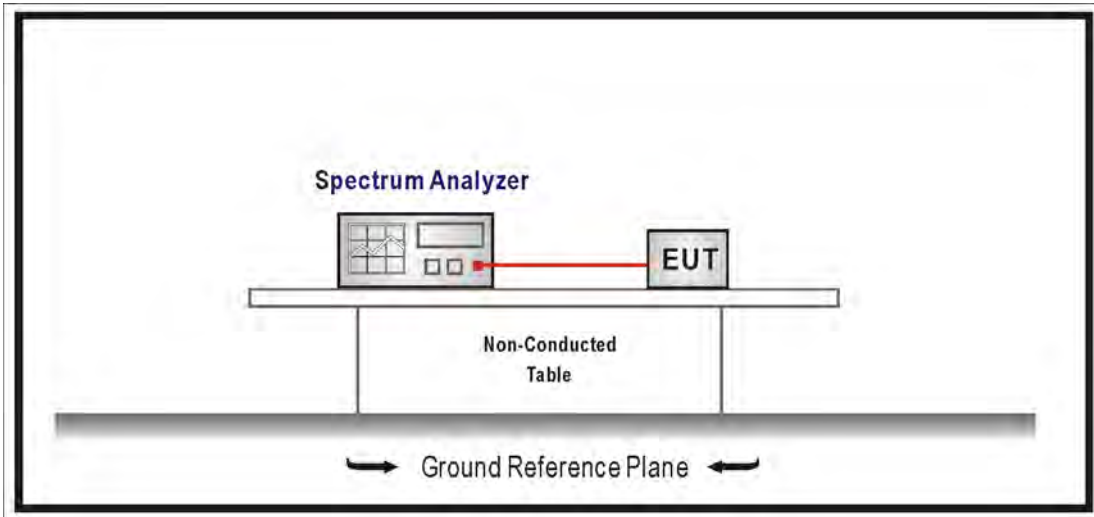

5.3. Limits

In any 100 kHz bandwidth outside the frequency band in which the spread spectrum intentional radiator is operating, the radio frequency power that is produced by the intentional radiator shall be at least 20 dB below that in the 100 kHz bandwidth within the band that contains the highest level of the desired power, based on an RF conducted or radiated measurement. Attenuation below the general limits specified in Section 15.209(a) is not required. In addition, radiated emissions which fall in the restricted bands, as defined in Section 15.205(a), must also comply with the radiated emission limits specified in Section 15.209(a) (see Section 15.205(c)).

5.4. Test Procedure

The EUT was setup according to ANSI C63.10:2013 and tested according to DTS test procedure section 11.2 of KDB558074 v03r02 for compliance to FCC 47CFR 15.247 requirements. Set RBW = 100 kHz, Set VBW > RBW, scan up through 10th harmonic.

5.5. Test Specification

According to FCC Part 15 Subpart C Paragraph 15.247: 2014

5.6. Uncertainty

Conducted is defined as $\pm 1.27\text{dB}$

5.7. Test Result

Product	ASUS SRT-AC1900 Wireless Smart Router		
Test Item	RF antenna conducted test		
Test Mode	Mode 1: Tx- AUX Antenna (AD891M21)		
Date of Test	2015/08/10	Test Site	SR7

IEEE 802.11b (ANT 0)				
Channel No.	Frequency (MHz)	Measure Level (dBc)	Limit (dBc)	Result
1	2412	35.58	≥ 30	Pass
6	2437	60.25	≥ 30	Pass
11	2462	58.06	≥ 30	Pass

Channel 1 (2412MHz)

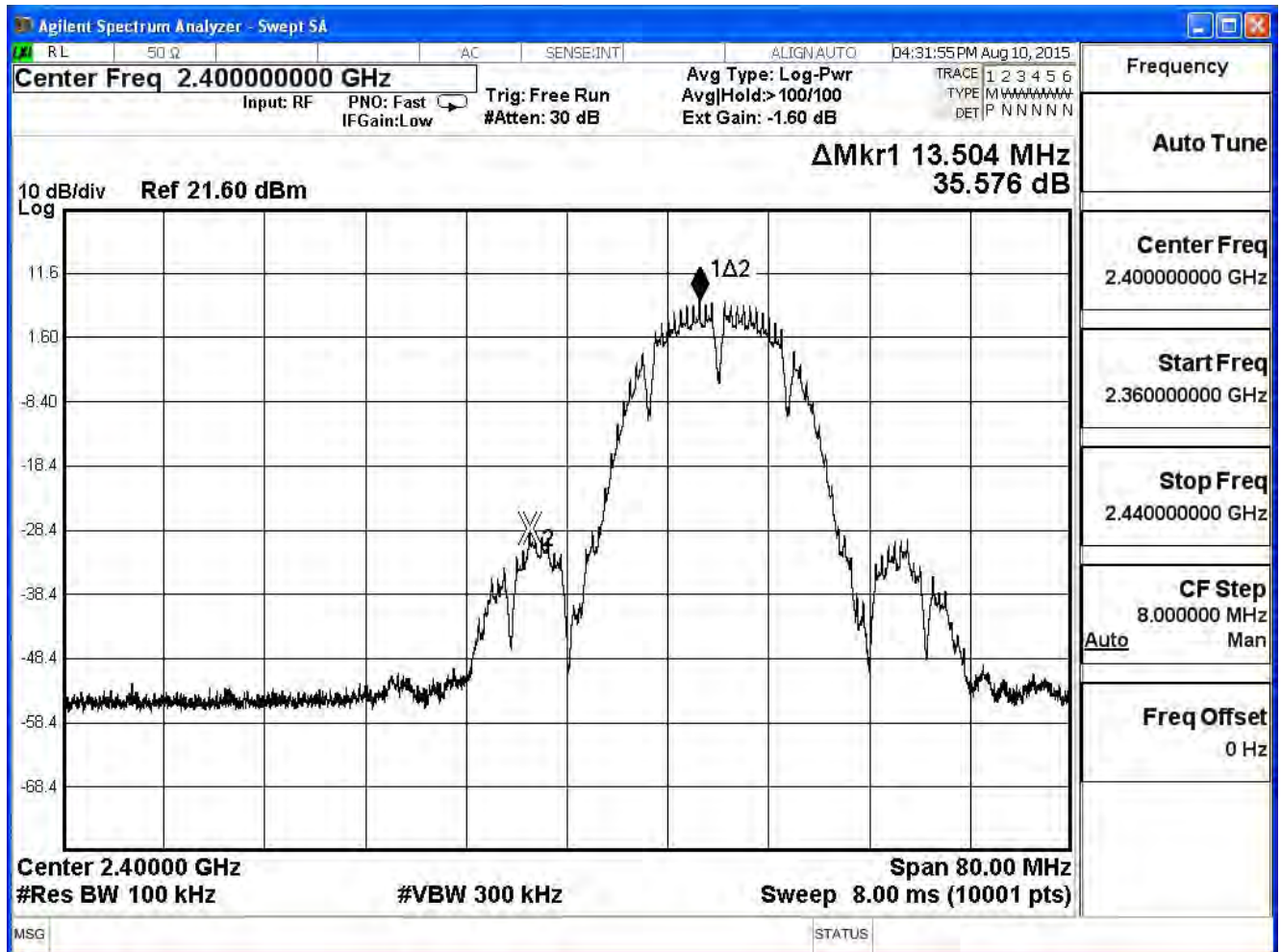

Channel 6 (2437MHz)

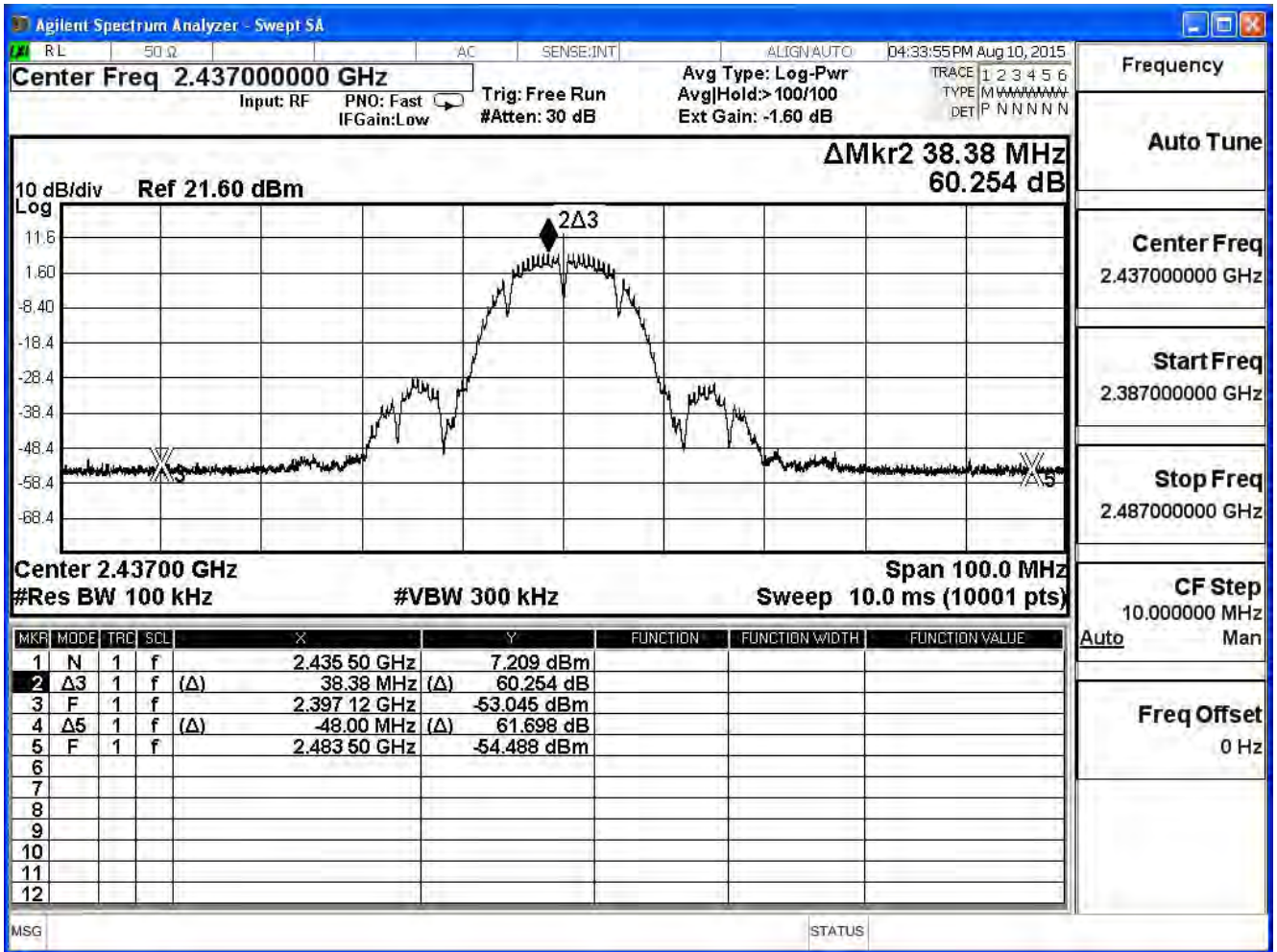

Channel 11 (2462MHz)

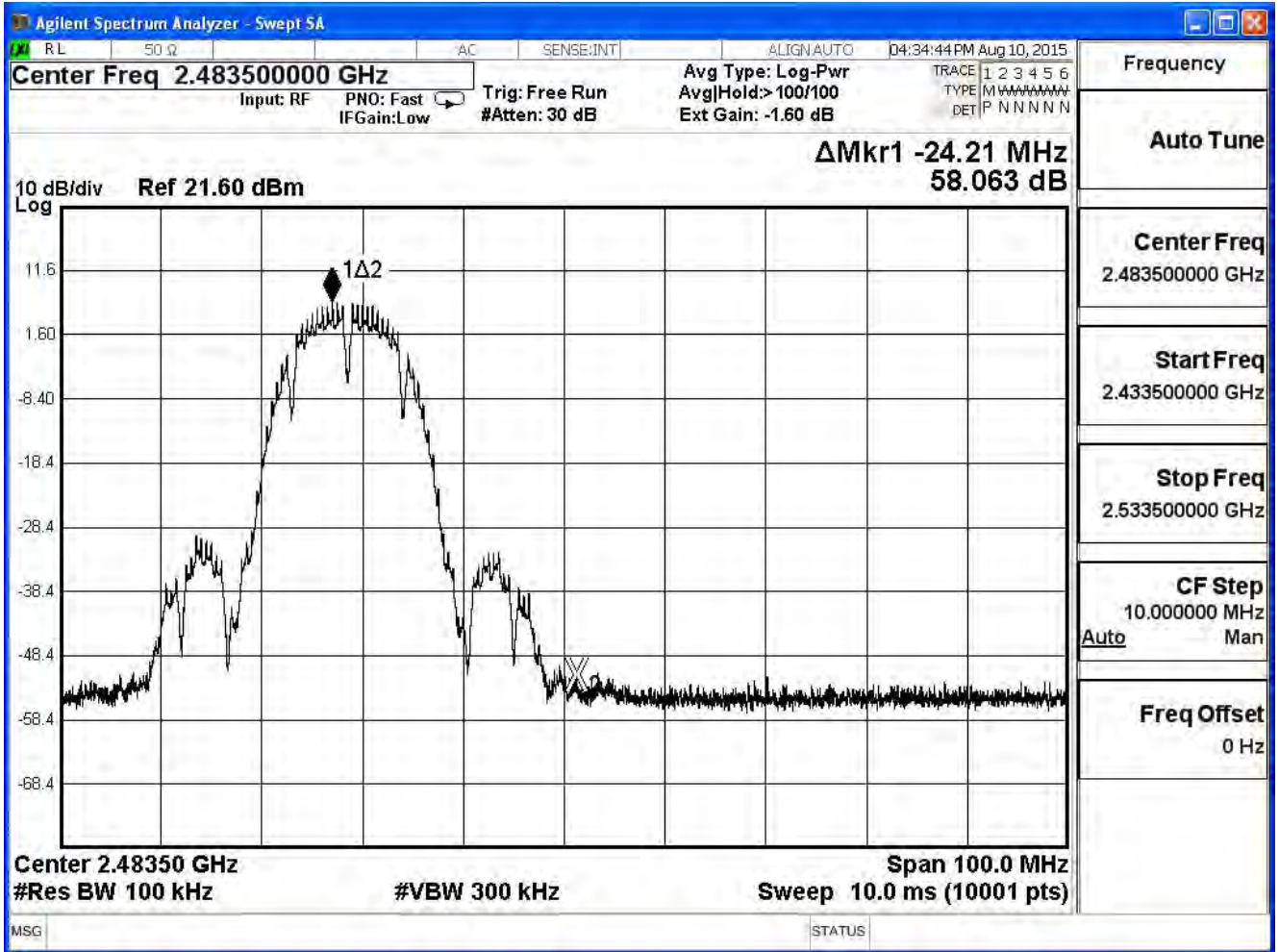

Product	ASUS SRT-AC1900 Wireless Smart Router		
Test Item	RF antenna conducted test		
Test Mode	Mode 1: Tx- AUX Antenna (AD891M21)		
Date of Test	2015/08/10	Test Site	SR7

IEEE 802.11g (ANT 0)				
Channel No.	Frequency (MHz)	Measure Level (dBc)	Limit (dBc)	Result
1	2412	31.05	≥ 30	Pass
6	2437	57.85	≥ 30	Pass
11	2462	45.46	≥ 30	Pass

Channel 1 (2412MHz)

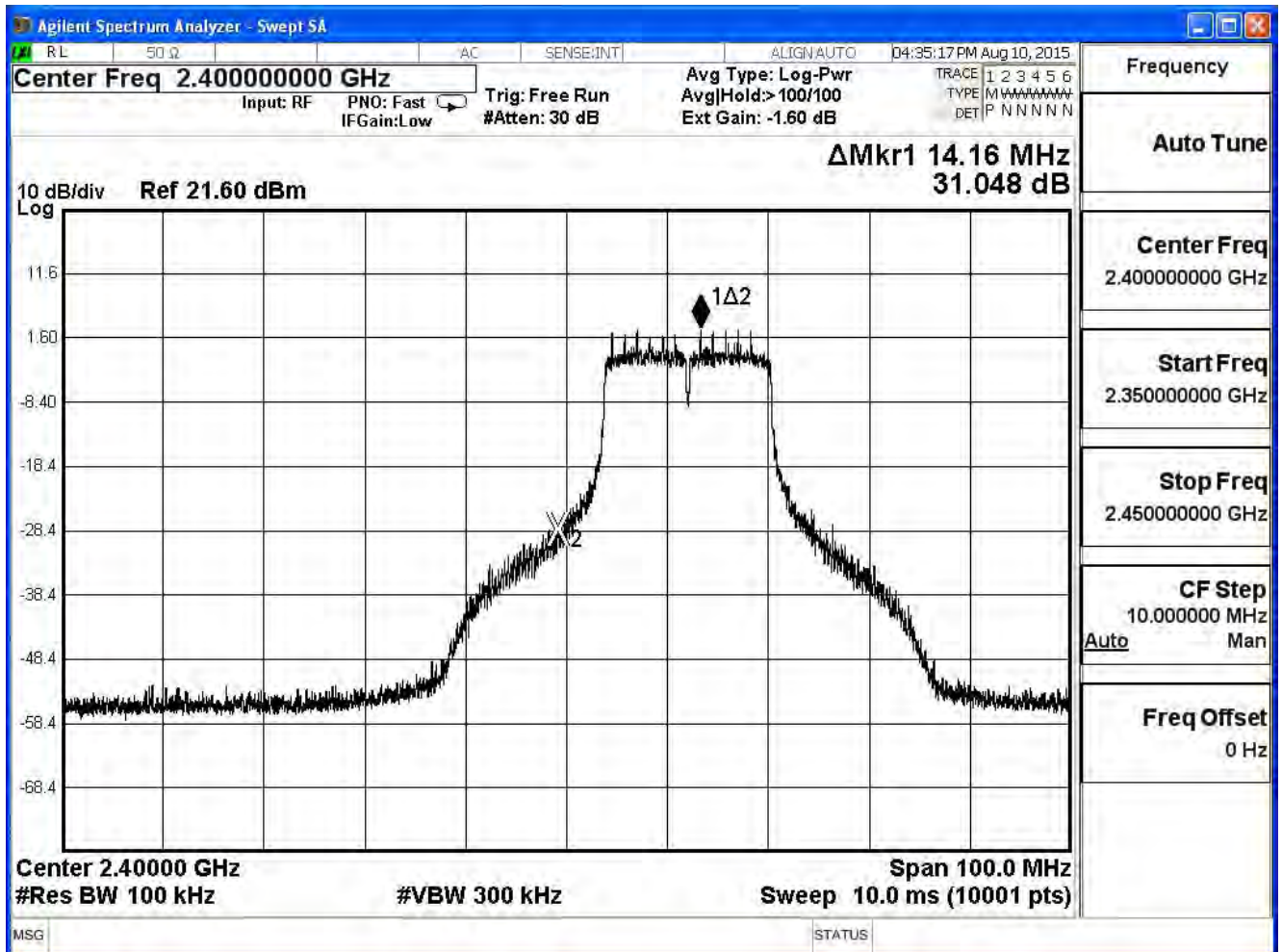

Channel 6 (2437MHz)

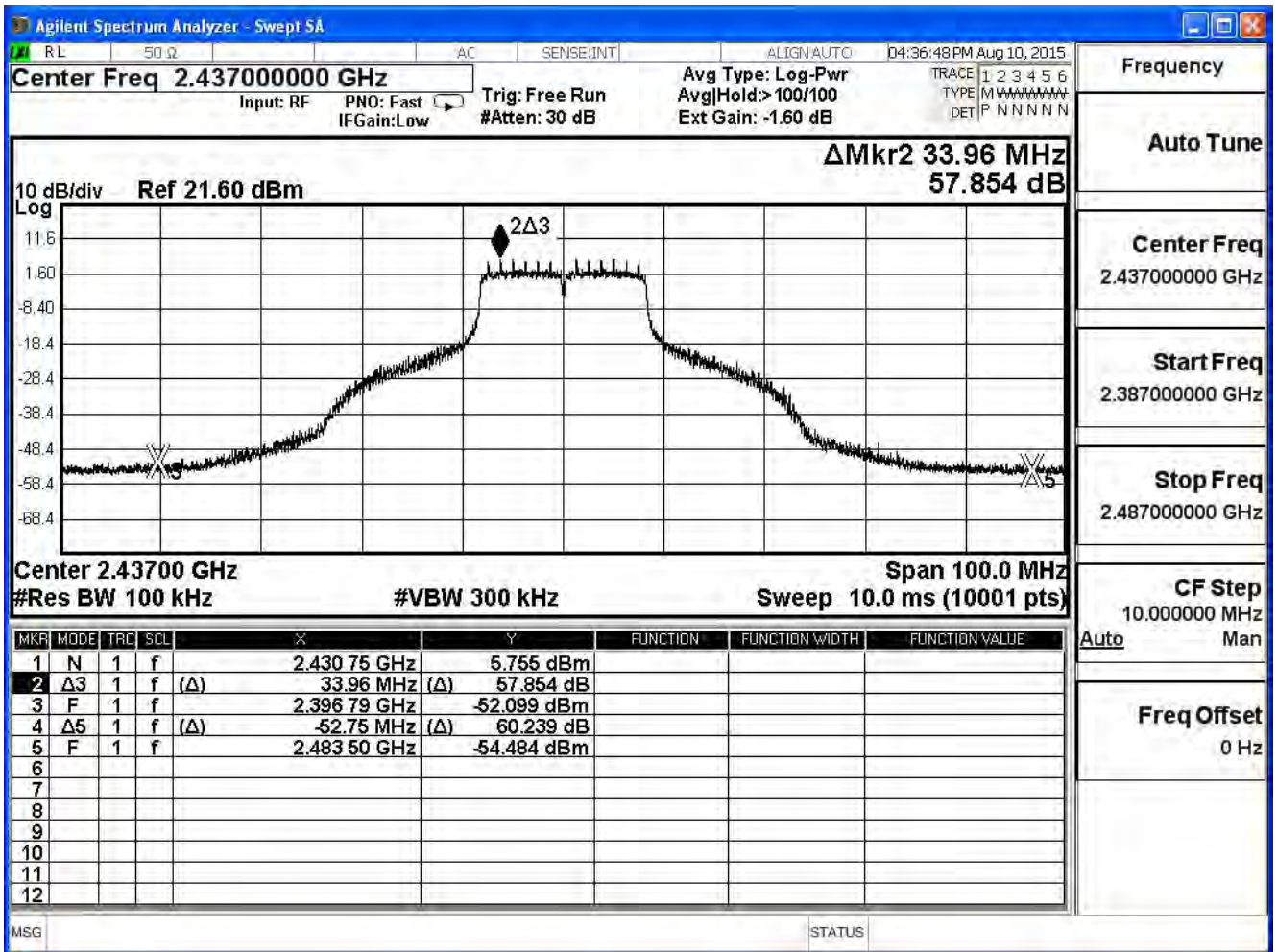

Channel 11 (2462MHz)

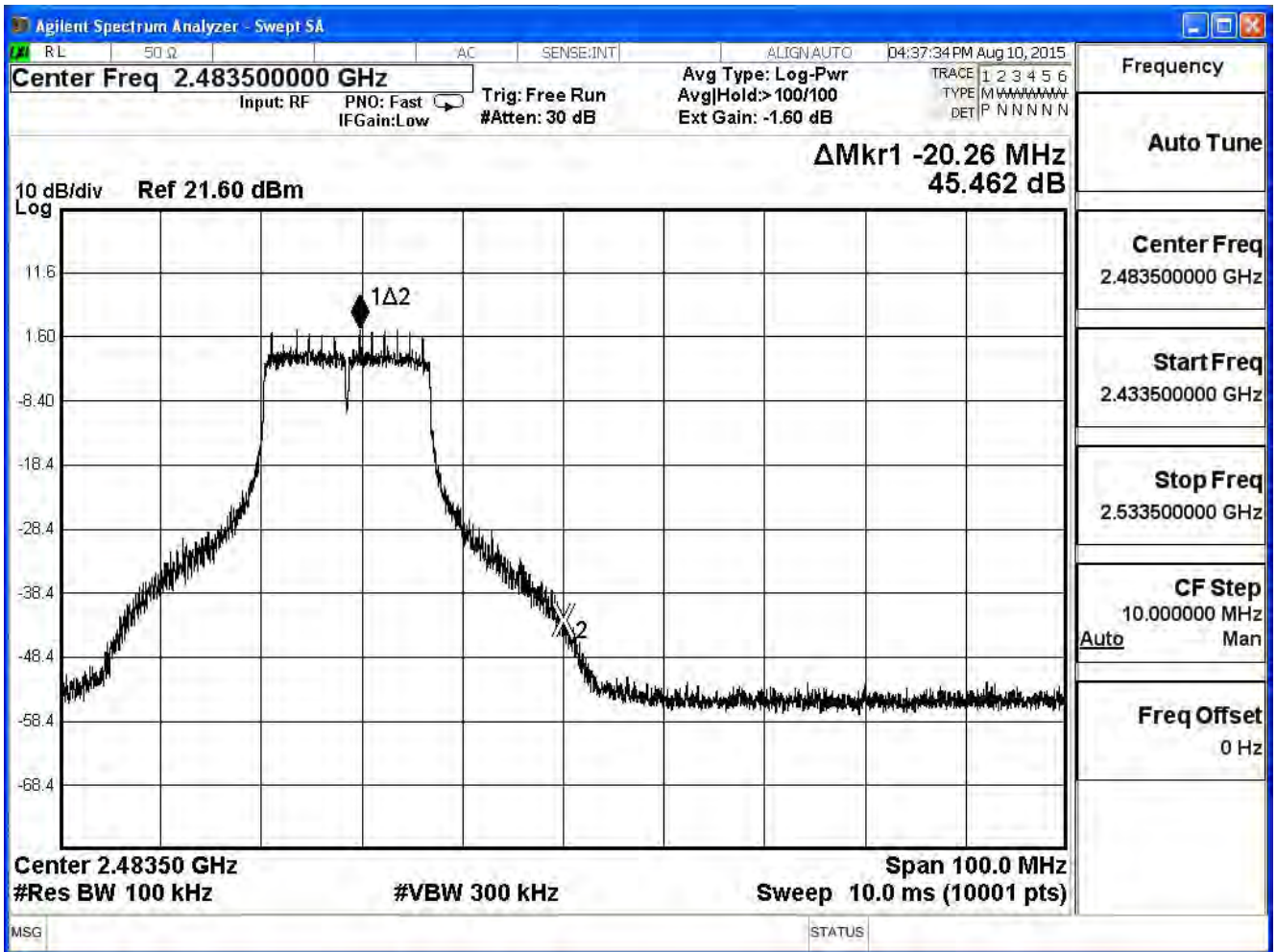

Product	ASUS SRT-AC1900 Wireless Smart Router		
Test Item	RF antenna conducted test		
Test Mode	Mode 1: Tx- AUX Antenna (AD891M21)		
Date of Test	2015/08/10	Test Site	SR7

IEEE 802.11n (20MHz) (ANT 0)				
Channel No.	Frequency (MHz)	Measure Level (dBc)	Limit (dBc)	Result
1	2412	30.79	≥ 30	Pass
6	2437	57.58	≥ 30	Pass
11	2462	44.13	≥ 30	Pass

Channel 1 (2412MHz)

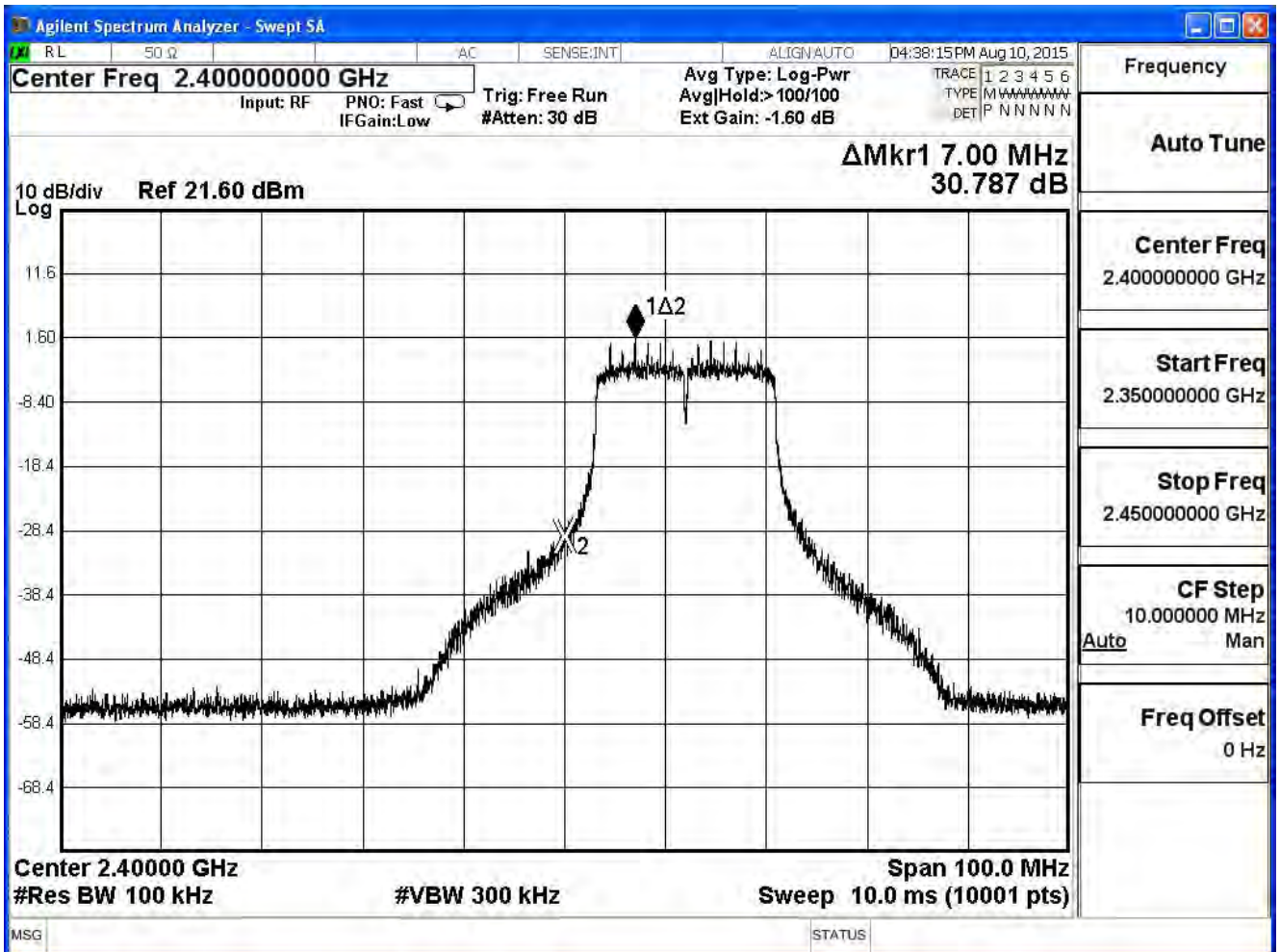

Channel 6 (2437MHz)

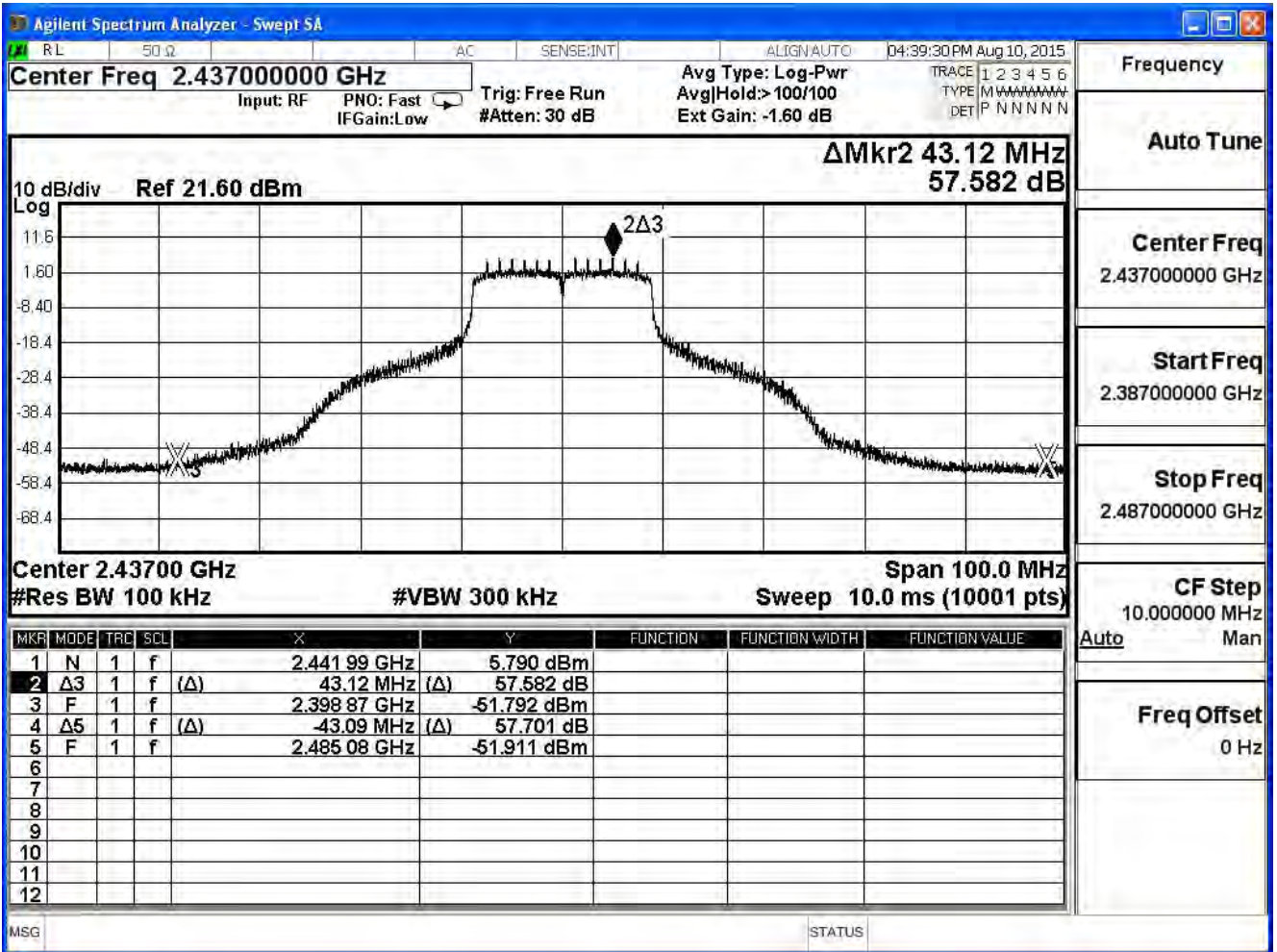

Channel 11 (2462MHz)

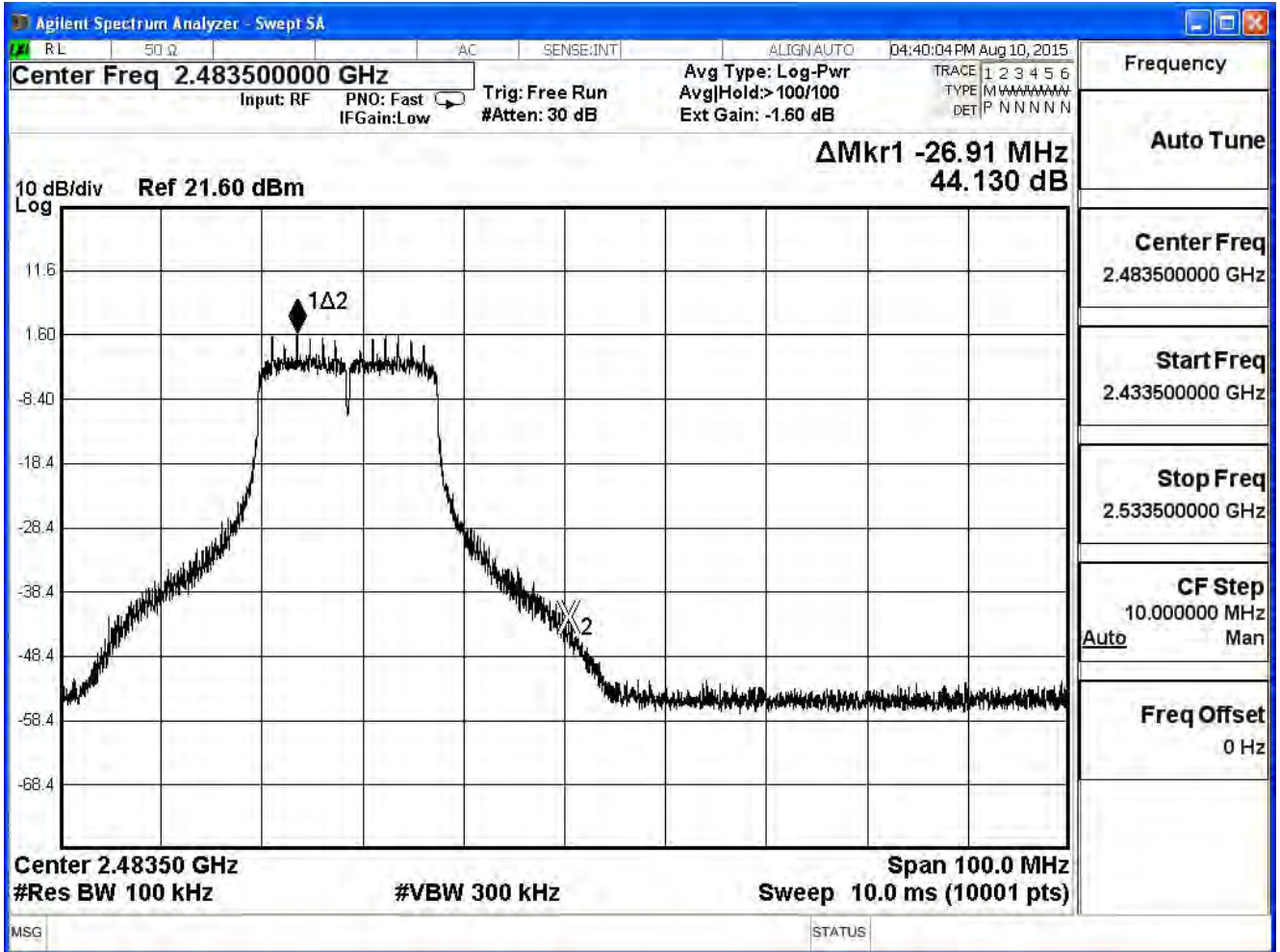

Product	ASUS SRT-AC1900 Wireless Smart Router		
Test Item	RF antenna conducted test		
Test Mode	Mode 1: Tx- AUX Antenna (AD891M21)		
Date of Test	2015/08/10	Test Site	SR7

IEEE 802.11n (40MHz) (ANT 0)				
Channel No.	Frequency (MHz)	Measure Level (dBc)	Limit (dBc)	Result
3	2422	31.49	≥ 30	Pass
6	2437	32.68	≥ 30	Pass
9	2452	37.75	≥ 30	Pass

Channel 3 (2422MHz)

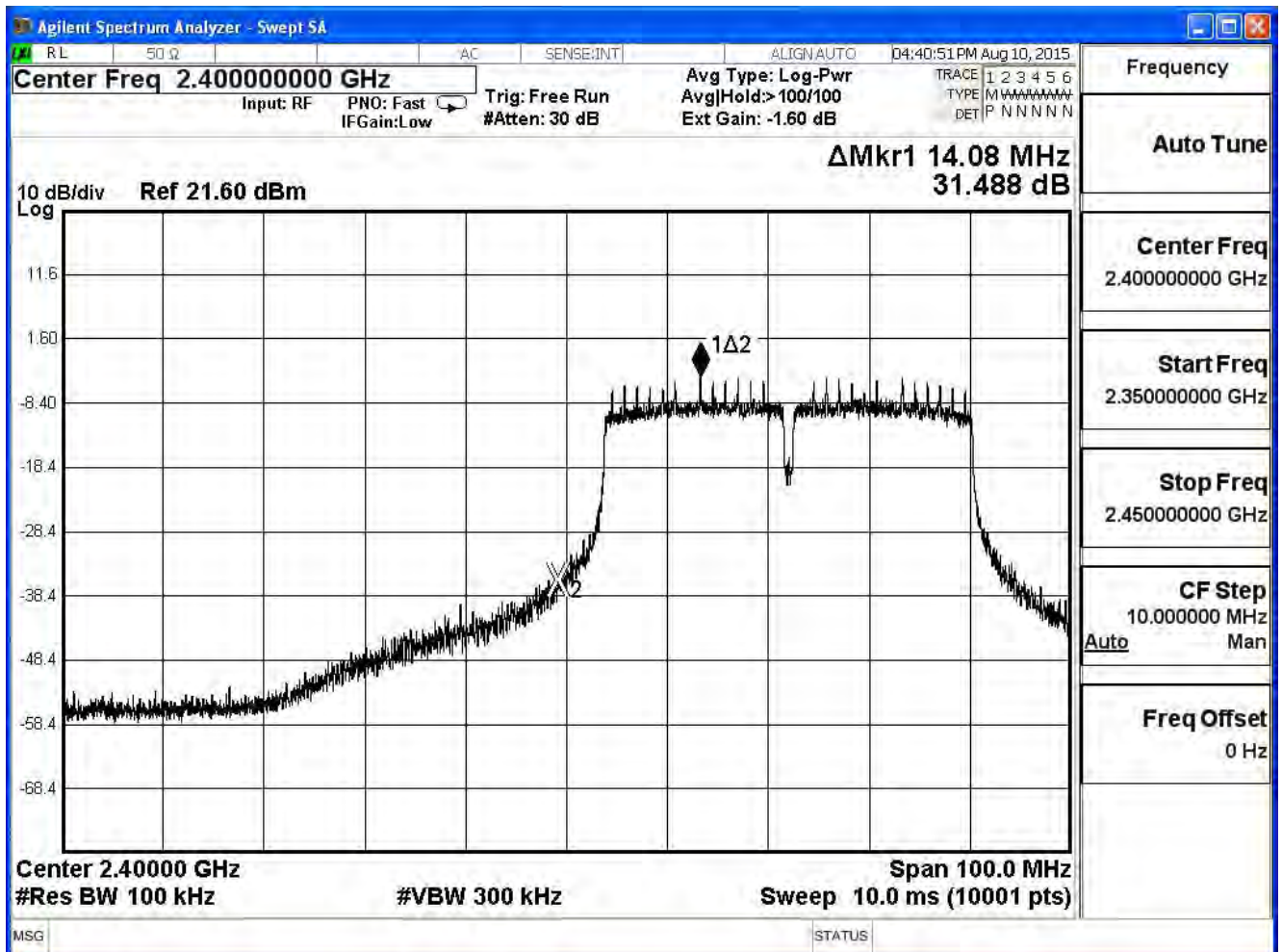

Channel 6 (2437MHz)

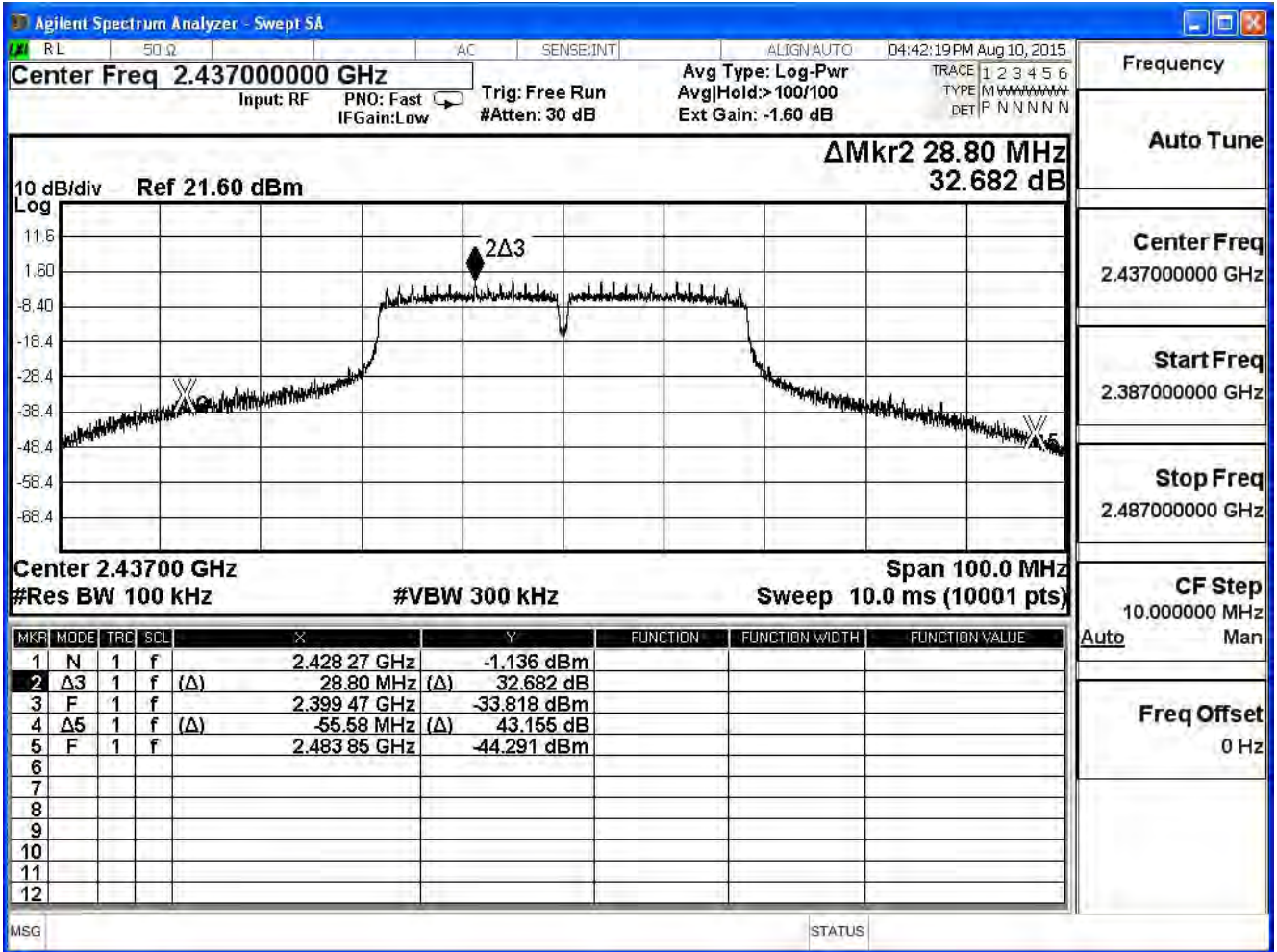

Channel 9 (2452MHz)

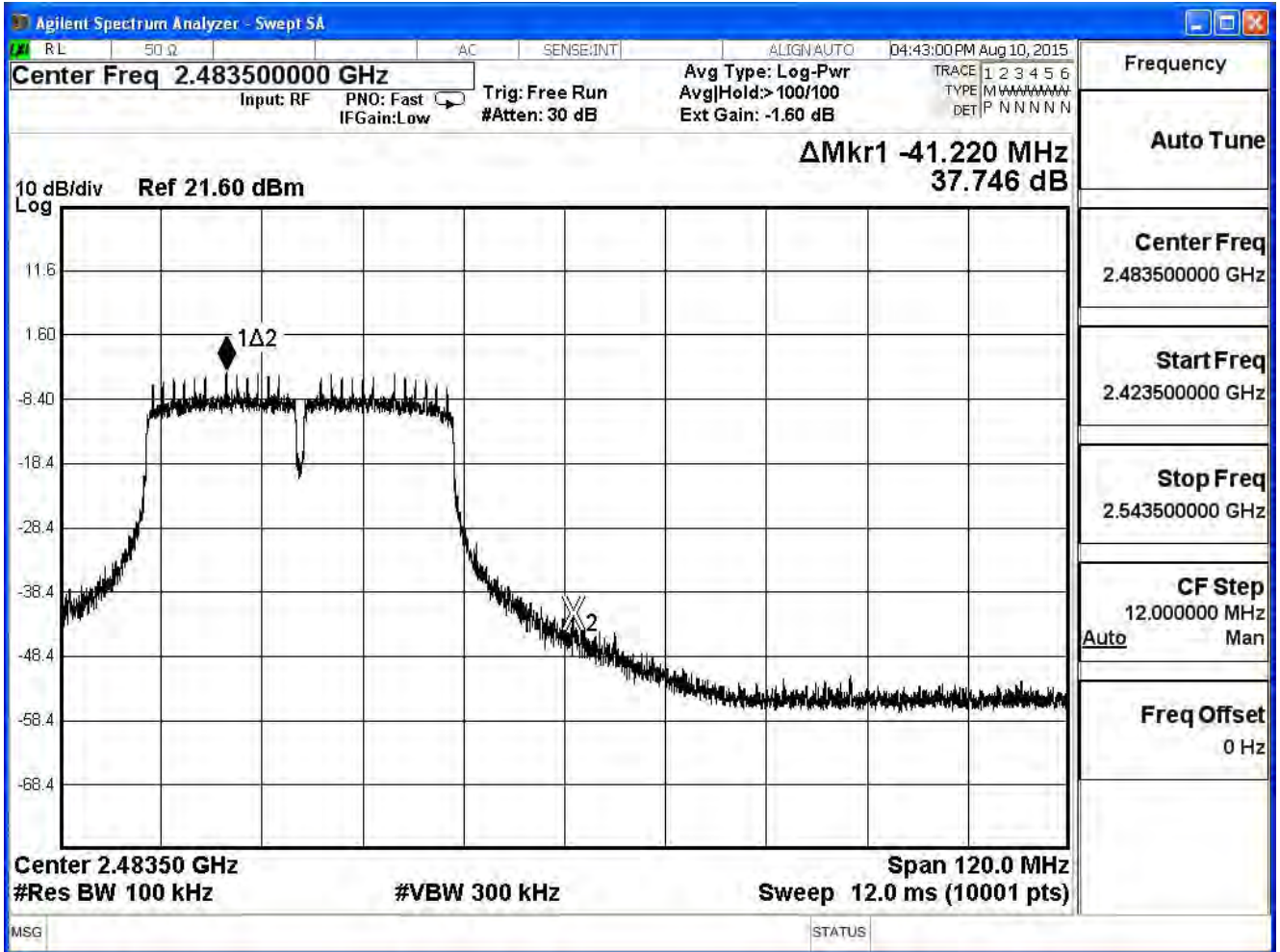

2412MHz (30MHz-25GHz)-802.11b(ANT 0)

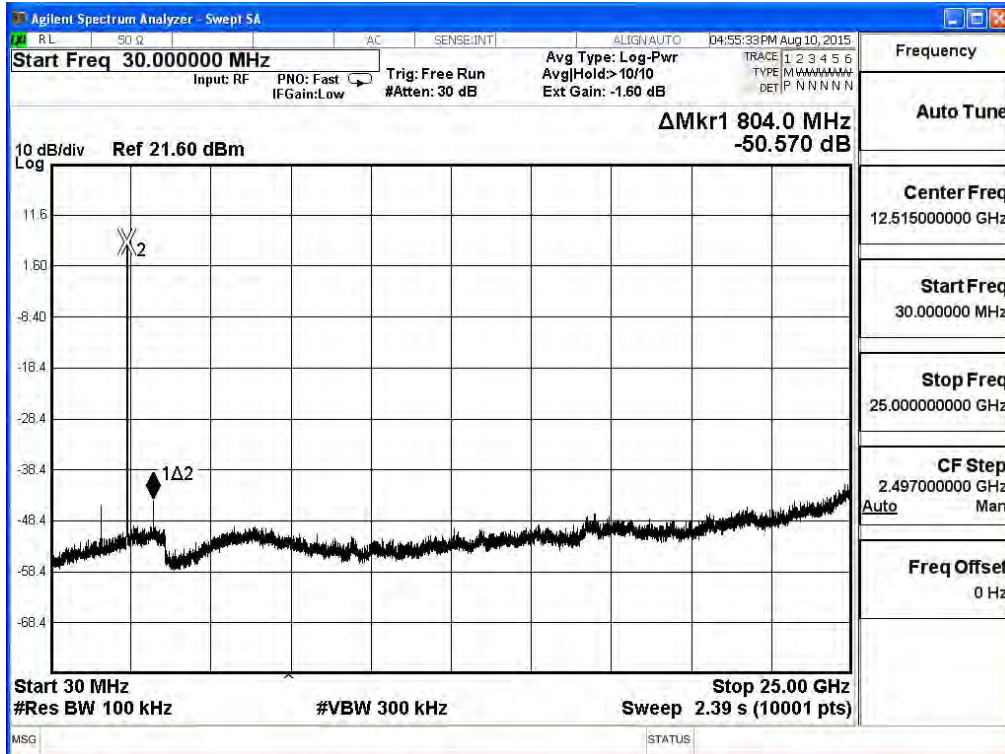

2437MHz (30MHz-25GHz)-802.11b(ANT 0)

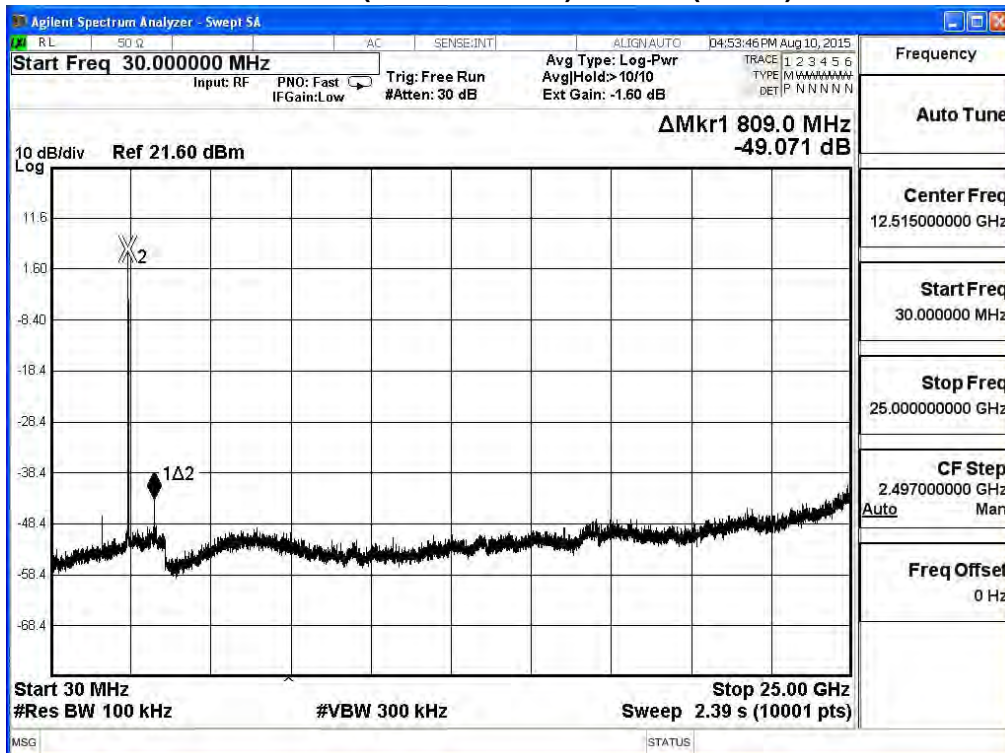

2462MHz (30MHz-25GHz)-802.11b(ANT 0)

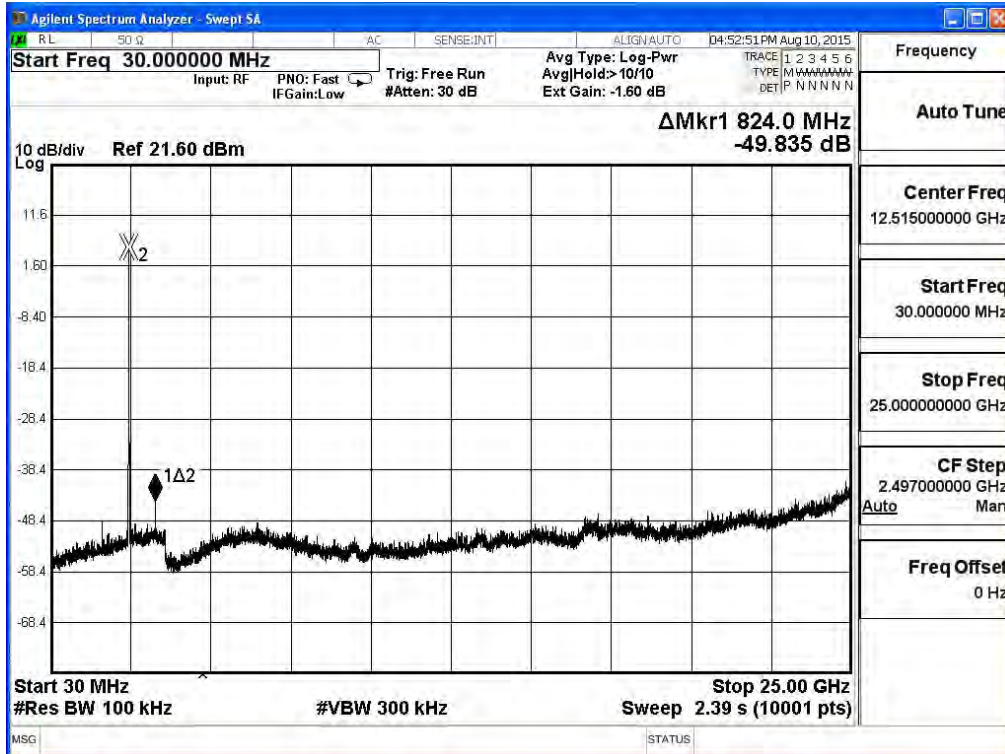

2412MHz (30MHz-25GHz)-802.11g(ANT 0)

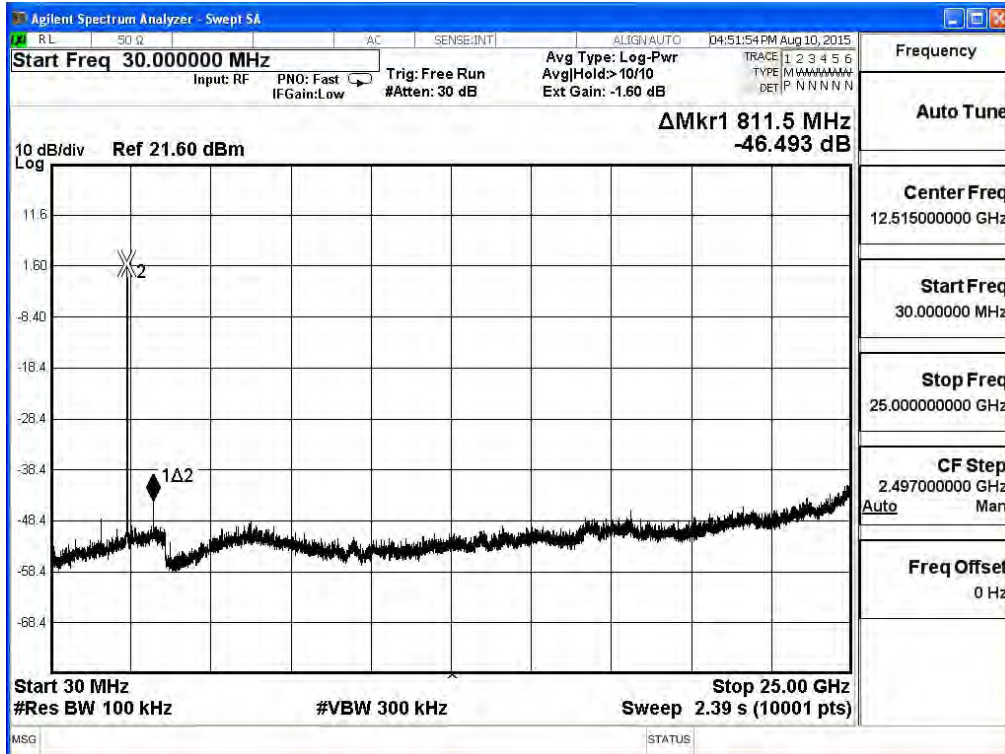

2437MHz (30MHz-25GHz)-802.11g(ANT 0)

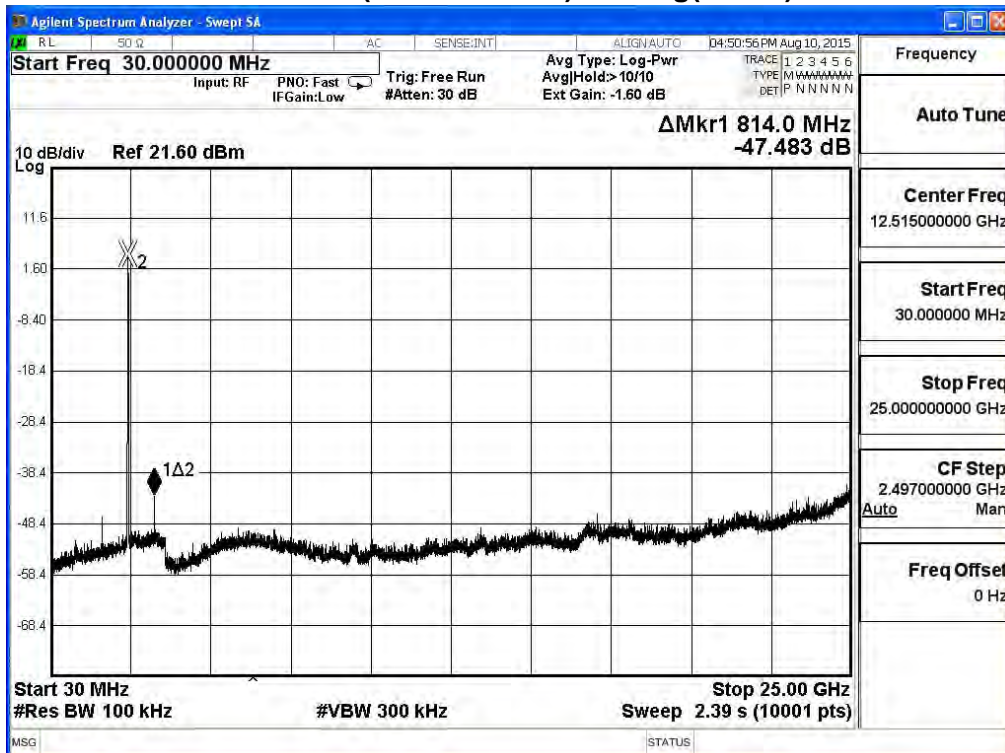

2462MHz (30MHz-25GHz)- 802.11g(ANT 0)

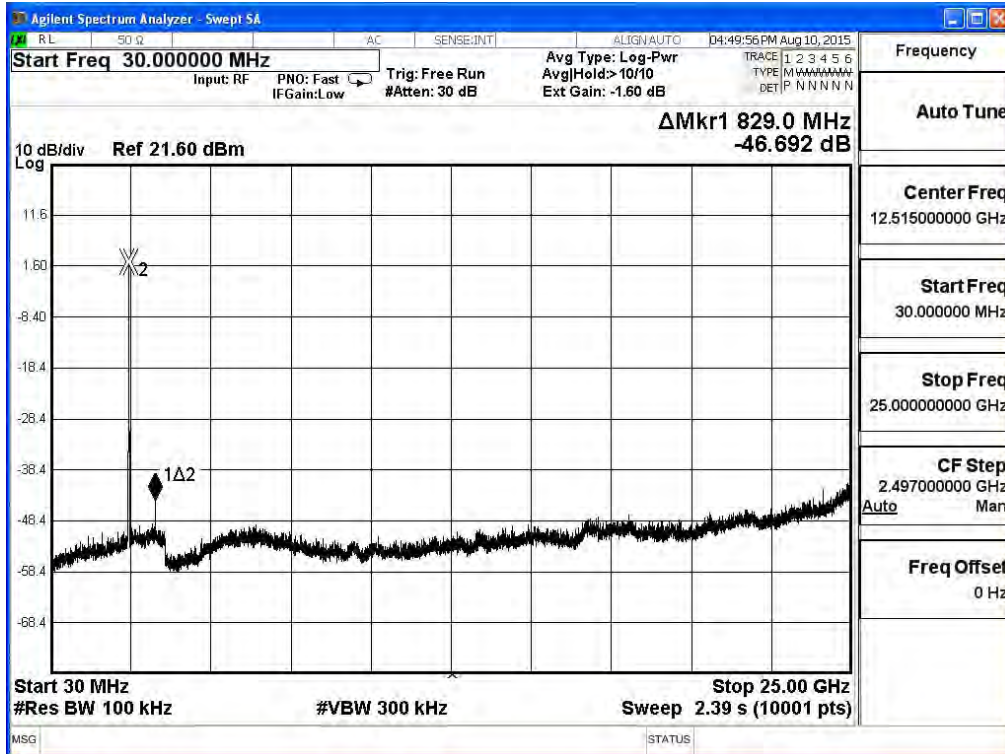

2412MHz (30MHz-25GHz)- 802.11n (20MHz)(ANT 0)

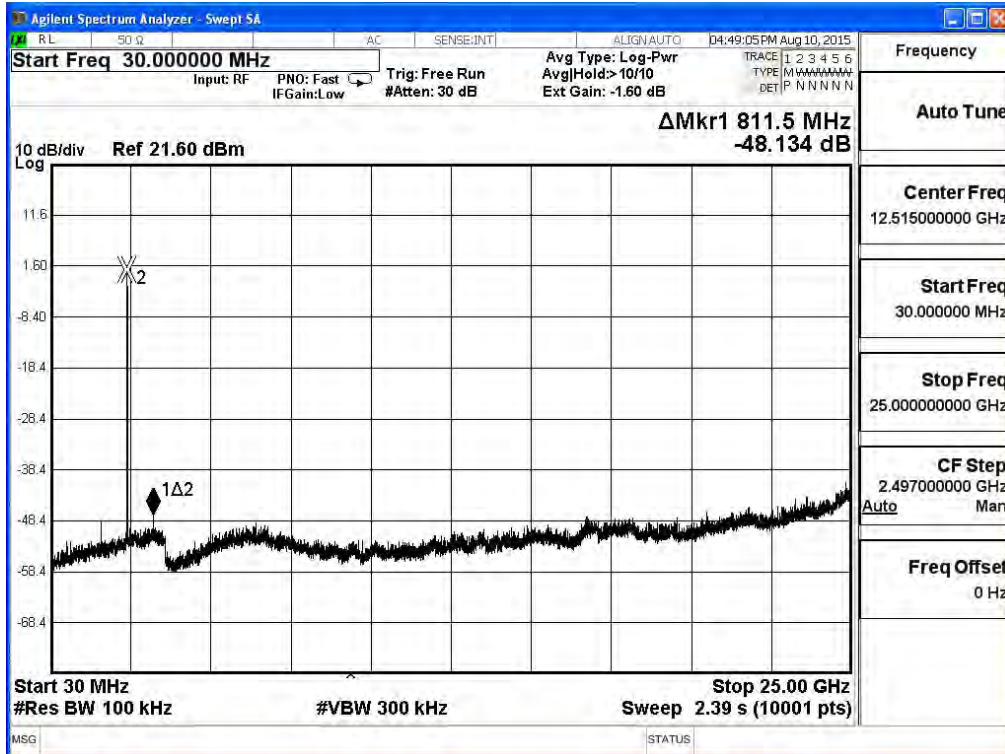

2437MHz (30MHz-25GHz)- 802.11n (20MHz)(ANT 0)

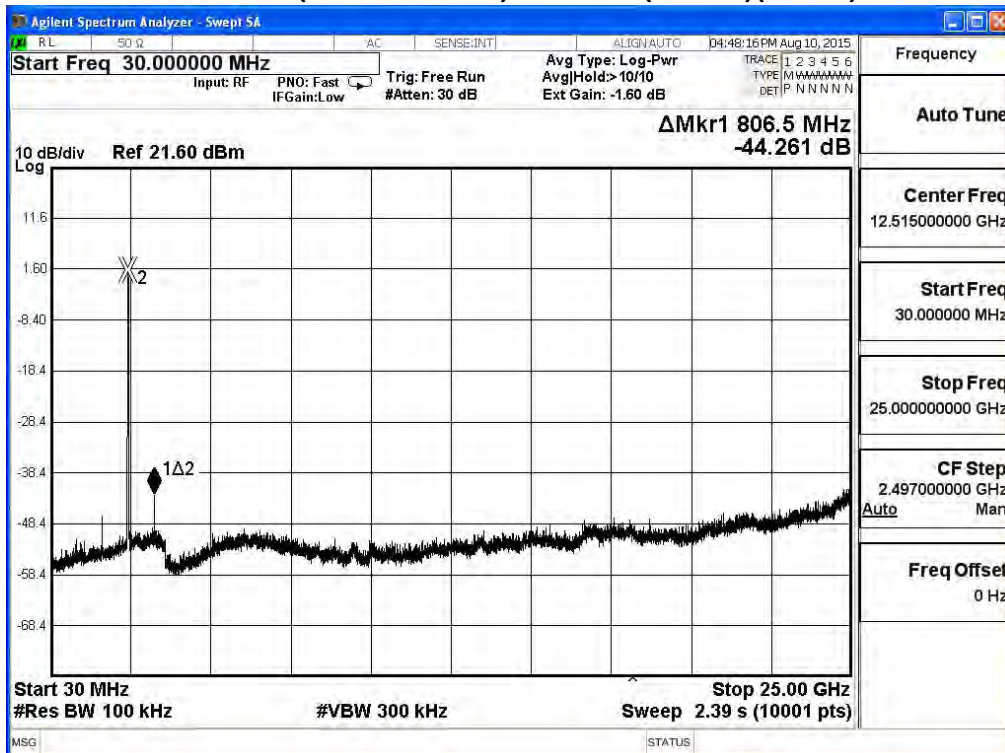

2462MHz (30MHz-25GHz)- 802.11n (20MHz)(ANT 0)

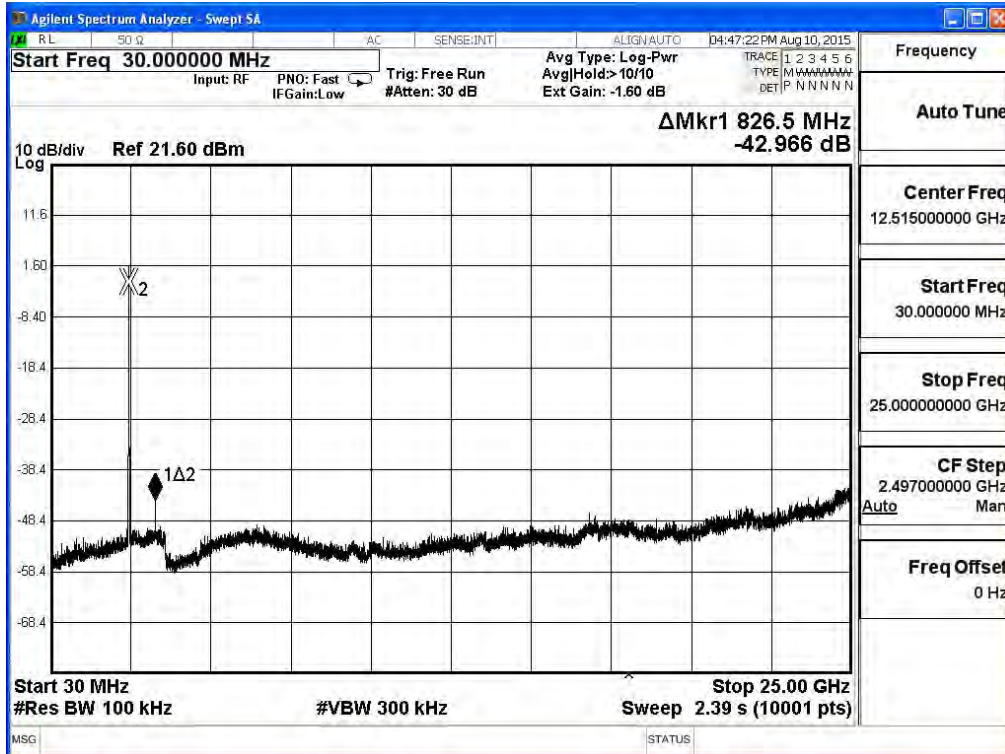

2422MHz (30MHz-25GHz)-802.11n(40MHz) (Ant 0)

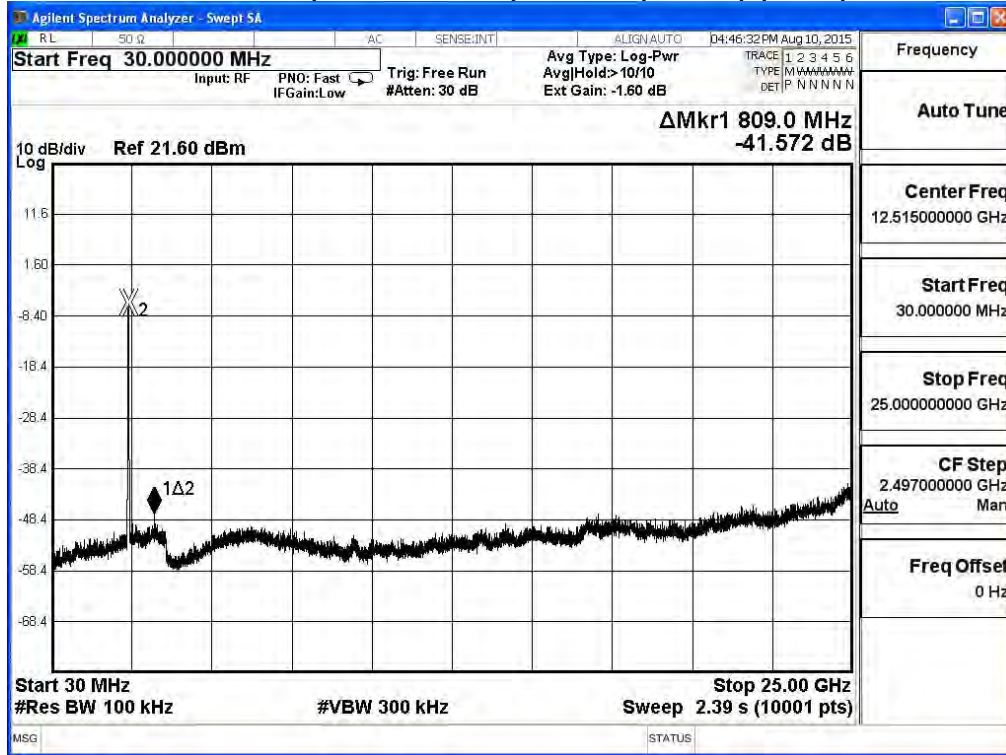

2437MHz (30MHz-1GHz)-802.11n(40MHz) (Ant 0)

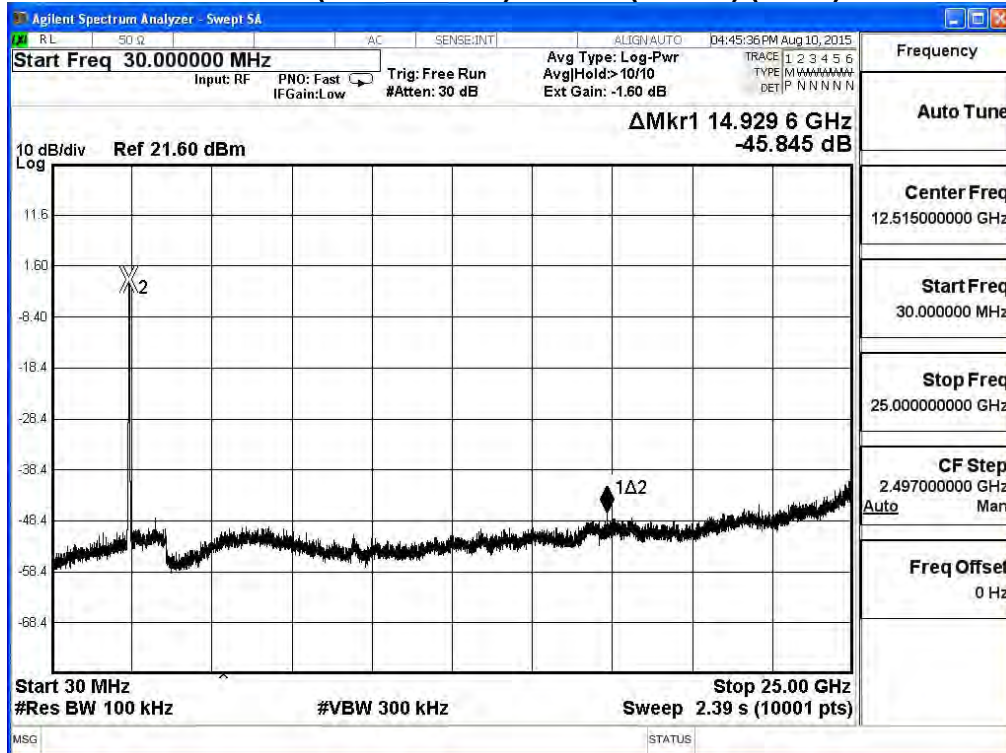

2452MHz (30MHz-25GHz)-802.11n(40MHz) (Ant 0)

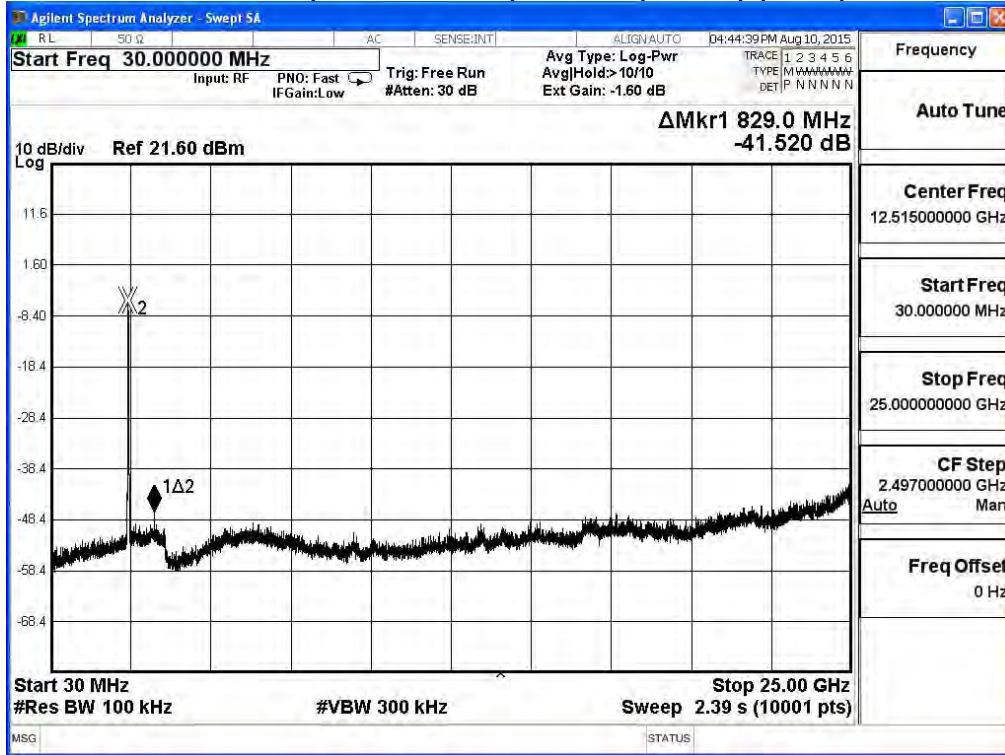

6. Radiated Emission Band Edge

6.1. Test Equipment

The following test equipments are used during the test:

Radiated Emission Band Edge / CB1

Instrument	Manufacturer	Model No.	Serial No	Next Cal. Date
Double Ridged Guide Horn Antenna	Schwarzback	BBHA 9120	D743	2016/01/26
Spectrum Analyzer	Agilent	E4440A	MY46187335	2016/01/07
k Type Cable	Huber Suhner	Sucoflex 102	25623/2	2016/01/26

Note: 1. All equipments that need to calibrate are with calibration period of 1 year.

6.2. Test Setup

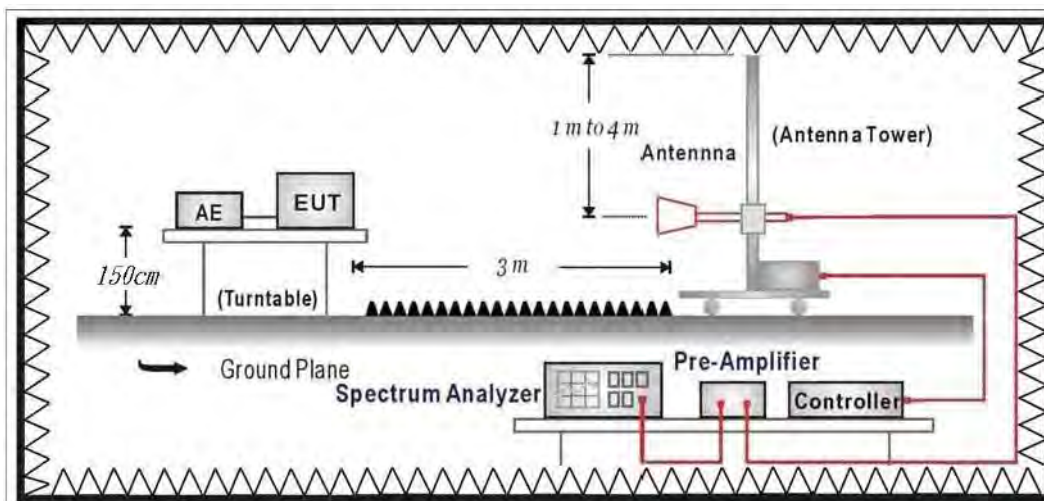

6.3. Limits

Emissions radiated outside of the specified frequency bands, except for harmonics, shall be attenuated by at least 20dB below the level of the fundamental or to the general radiated emission limits in paragraph 15.209, whichever is the lesser attenuation.

6.4. Test Procedure

The EUT was setup according to ANSI C63.10:2013 and tested according to DTS test procedure of KDB558074 v03r02 for compliance to FCC 47CFR 15.247 requirements. The EUT and its simulators are placed on a turn table which is 1.5 meter above ground. The turn table can rotate 360 degrees to determine the position of the maximum emission level. The EUT was positioned such that the distance from antenna to the EUT was 3 meters.

The antenna can move up and down between 1 meter and 4 meters to find out the maximum emission level.

Both horizontal and vertical polarization of the antenna are set on measurement. In order to find the maximum emission, all of the interface cables must be manipulated according to ANSI C63.10:2013 on radiated measurement.

6.5. Test Specification

According to FCC Part 15 Subpart C Paragraph 15.247: 2014

6.6. Uncertainty

The measurement uncertainty
 ± 3.9 dB above 1GHz

6.7. Test Result

Radiated is defined as

Site : CB1	Time : 2015/07/28 - 20:55
Limit : FCC_SpartC_15.247_H_03M_PK	Margin : 6
Probe : CB1_FCC_EFS_1-18G_H2 - HORIZONTAL	Power : AC 120 V / 60Hz
EUT : ASUS SRT-AC1900 Wireless Smart Router	Note : Mode 1: Tx- AUX Antenna (AD891M21) 802.11b_2412MHz

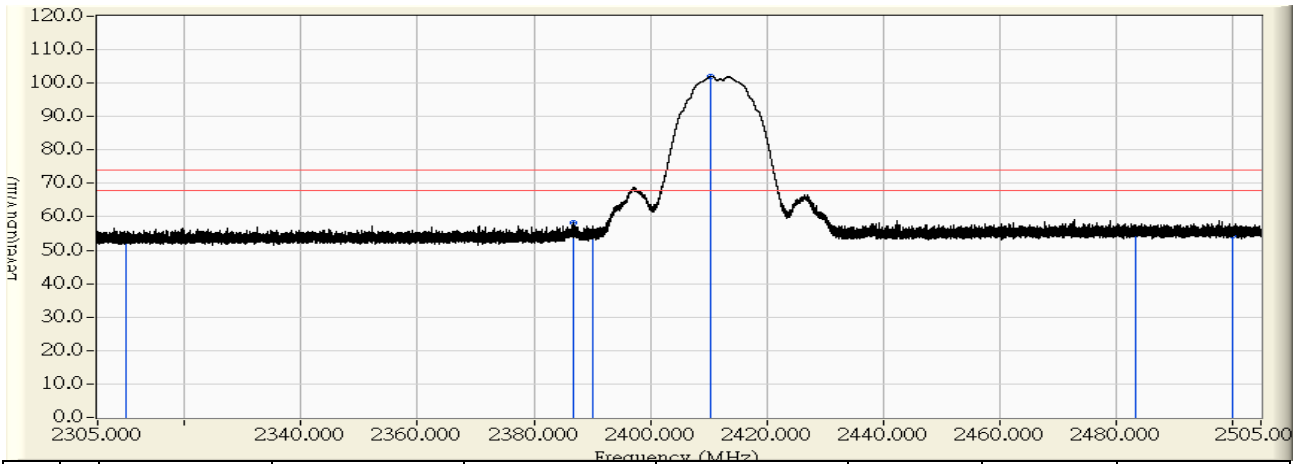

	Frequency (MHz)	Correct Factor (dB)	Reading Level (dBuV)	Measure Level (dBuV/m)	Margin (dB)	Limit (dBuV/m)	Detector Type
1	2310.000	28.130	24.719	52.849	-21.151	74.000	PEAK
2	2386.716	28.900	29.222	58.122	-15.878	74.000	PEAK
3	2390.000	28.933	25.563	54.496	-19.504	74.000	PEAK
4	* 2410.490	29.139	72.922	102.061	28.061	74.000	PEAK
5	2483.500	29.829	25.952	55.781	-18.219	74.000	PEAK
6	2500.000	29.826	24.652	54.477	-19.523	74.000	PEAK

Note:

1. All readings above 1GHz are performed with peak and/or average measurements as necessary.
2. Peak measurements: RBW = 1MHz, VBW = 3 MHz, Sweep: Auto.
3. Average measurements: RBW = 1MHz, VBW = 10 Hz, Sweep: Auto.
4. " * ", means this data is the worst emission level.
5. Measurement Level = Reading Level + Correct Factor.
6. The average measurement was not performed when the peak measured data under the limit of average detection.

Site : CB1	Time : 2015/07/28 - 20:55
Limit : FCC_SpartC_15.247_H_03M_AV	Margin : 6
Probe : CB1_FCC_EFS_1-18G_H2 - HORIZONTAL	Power : AC 120 V / 60Hz
EUT : ASUS SRT-AC1900 Wireless Smart Router	Note : Mode 1: Tx- AUX Antenna (AD891M21) 802.11b_2412MHz

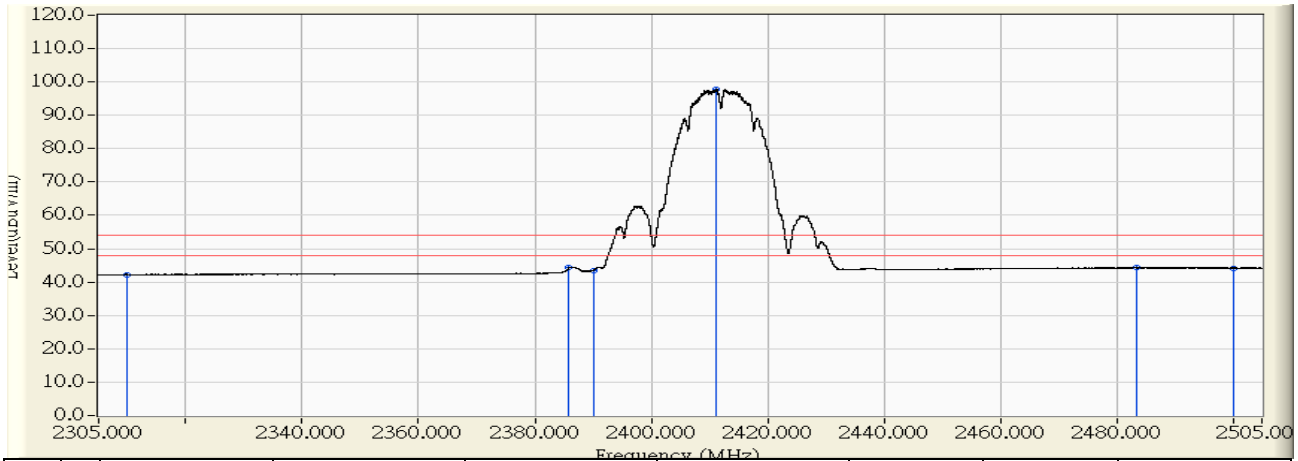

	Frequency (MHz)	Correct Factor (dB)	Reading Level (dBuV)	Measure Level (dBuV/m)	Margin (dB)	Limit (dBuV/m)	Detector Type
1	2310.000	28.130	14.127	42.257	-11.743	54.000	AVERAGE
2	2385.879	28.892	15.361	44.253	-9.747	54.000	AVERAGE
3	2390.000	28.933	14.550	43.483	-10.517	54.000	AVERAGE
4	* 2411.159	29.145	68.791	97.937	43.937	54.000	AVERAGE
5	2483.500	29.829	14.419	44.248	-9.752	54.000	AVERAGE
6	2500.000	29.826	14.381	44.206	-9.794	54.000	AVERAGE

Note:

1. All readings above 1GHz are performed with peak and/or average measurements as necessary.
2. Peak measurements: RBW = 1MHz, VBW = 3 MHz, Sweep: Auto.
3. Average measurements: RBW = 1MHz, VBW = 10 Hz, Sweep: Auto.
4. “ * ”, means this data is the worst emission level.
5. Measurement Level = Reading Level + Correct Factor.
6. The average measurement was not performed when the peak measured data under the limit of average detection.

Site : CB1	Time : 2015/07/28 - 21:08
Limit : FCC_SpartC_15.247_H_03M_PK	Margin : 6
Probe : CB1_FCC_EFS_1-18G_H2 - VERTICAL	Power : AC 120 V / 60Hz
EUT : ASUS SRT-AC1900 Wireless Smart Router	Note : Mode 1: Tx- AUX Antenna (AD891M21) 802.11b_2412MHz

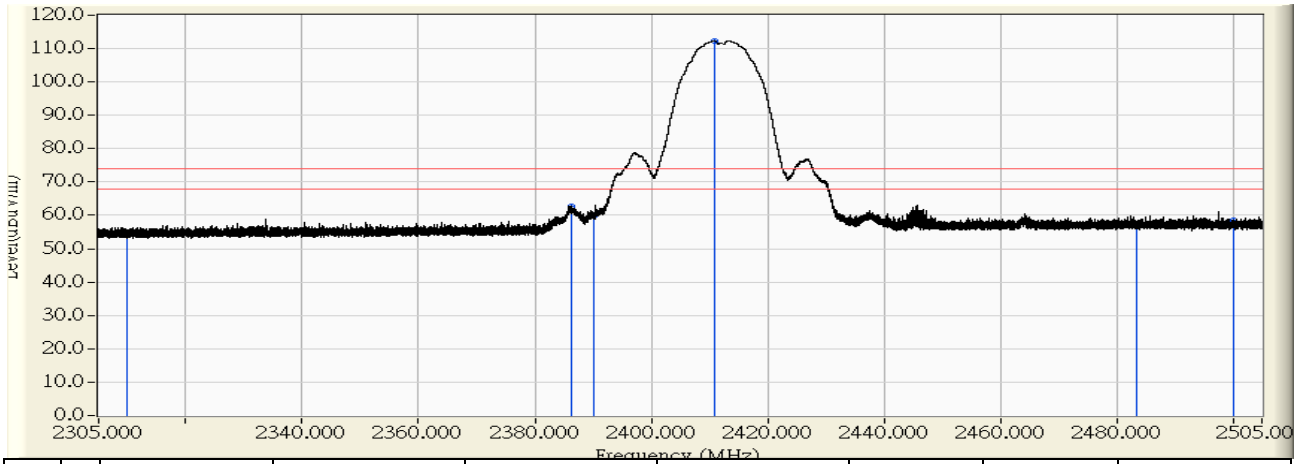

	Frequency (MHz)	Correct Factor (dB)	Reading Level (dBuV)	Measure Level (dBuV/m)	Margin (dB)	Limit (dBuV/m)	Detector Type
1	2310.000	28.784	25.502	54.286	-19.714	74.000	PEAK
2	2386.254	29.702	33.069	62.771	-11.229	74.000	PEAK
3	2390.000	29.747	30.231	59.978	-14.022	74.000	PEAK
4	* 2410.890	29.998	82.393	112.392	38.392	74.000	PEAK
5	2483.500	30.830	25.984	56.814	-17.186	74.000	PEAK
6	2500.000	30.860	27.539	58.398	-15.602	74.000	PEAK

Note:

1. All readings above 1GHz are performed with peak and/or average measurements as necessary.
2. Peak measurements: RBW = 1MHz, VBW = 3 MHz, Sweep: Auto.
3. Average measurements: RBW = 1MHz, VBW = 10 Hz, Sweep: Auto.
4. “ * ”, means this data is the worst emission level.
5. Measurement Level = Reading Level + Correct Factor.
6. The average measurement was not performed when the peak measured data under the limit of average detection.

Site : CB1	Time : 2015/07/28 - 21:11
Limit : FCC_SpartC_15.247_H_03M_AV	Margin : 6
Probe : CB1_FCC_EFS_1-18G_H2 - VERTICAL	Power : AC 120 V / 60Hz
EUT : ASUS SRT-AC1900 Wireless Smart Router	Note : Mode 1: Tx- AUX Antenna (AD891M21) 802.11b_2412MHz

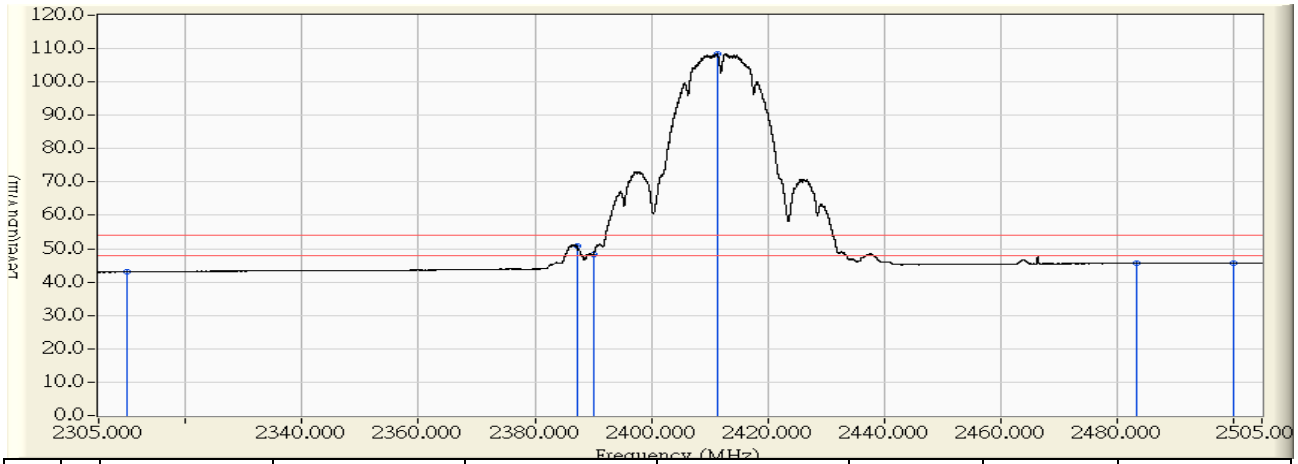

	Frequency (MHz)	Correct Factor (dB)	Reading Level (dBuV)	Measure Level (dBuV/m)	Margin (dB)	Limit (dBuV/m)	Detector Type
1	2310.000	28.784	14.214	42.998	-11.002	54.000	AVERAGE
2	2387.185	29.713	21.107	50.820	-3.180	54.000	AVERAGE
3	2390.000	29.747	18.373	48.120	-5.880	54.000	AVERAGE
4	* 2411.297	30.004	78.551	108.555	54.555	54.000	AVERAGE
5	2483.500	30.830	14.751	45.581	-8.419	54.000	AVERAGE
6	2500.000	30.860	14.742	45.601	-8.399	54.000	AVERAGE

Note:

1. All readings above 1GHz are performed with peak and/or average measurements as necessary.
2. Peak measurements: RBW = 1MHz, VBW = 3 MHz, Sweep: Auto.
3. Average measurements: RBW = 1MHz, VBW = 10 Hz, Sweep: Auto.
4. “ * ”, means this data is the worst emission level.
5. Measurement Level = Reading Level + Correct Factor.
6. The average measurement was not performed when the peak measured data under the limit of average detection.

Site : CB1	Time : 2015/07/28 - 21:48
Limit : FCC_SpartC_15.247_H_03M_PK	Margin : 6
Probe : CB1_FCC_EFS_1-18G_H2 - HORIZONTAL	Power : AC 120 V / 60Hz
EUT : ASUS SRT-AC1900 Wireless Smart Router	Note : Mode 1: Tx- AUX Antenna (AD891M21) 802.11b_2437MHz

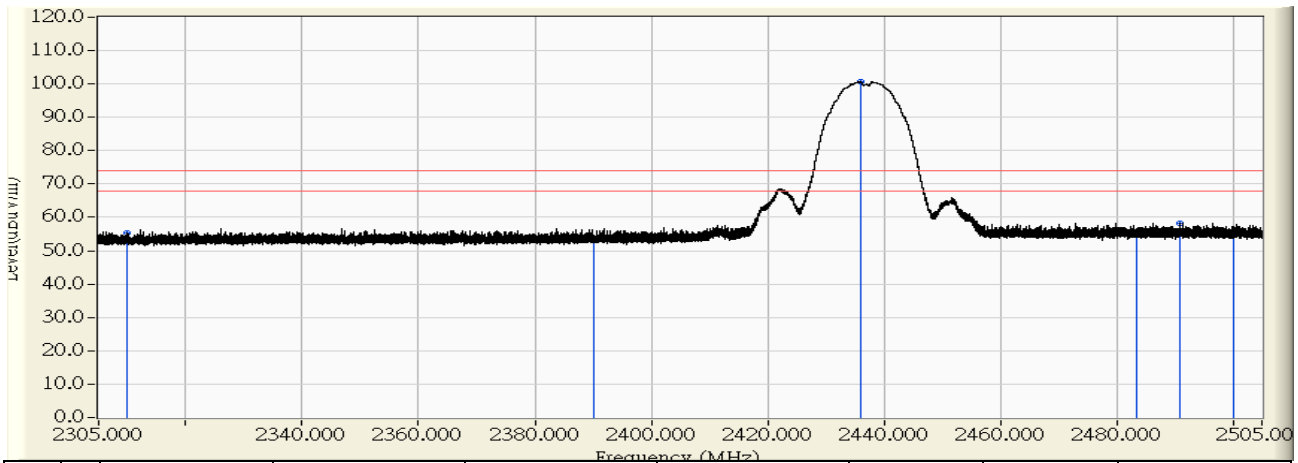

	Frequency (MHz)	Correct Factor (dB)	Reading Level (dBuV)	Measure Level (dBuV/m)	Margin (dB)	Limit (dBuV/m)	Detector Type
1	2310.000	28.130	27.110	55.240	-18.760	74.000	PEAK
2	2390.000	28.933	24.838	53.771	-20.229	74.000	PEAK
3	* 2435.983	29.395	71.221	100.616	26.616	74.000	PEAK
4	2483.500	29.829	24.986	54.815	-19.185	74.000	PEAK
5	2490.875	29.833	28.544	58.377	-15.623	74.000	PEAK
6	2500.000	29.826	25.754	55.579	-18.421	74.000	PEAK

Note:

1. All readings above 1GHz are performed with peak and/or average measurements as necessary.
2. Peak measurements: RBW = 1MHz, VBW = 3 MHz, Sweep: Auto.
3. Average measurements: RBW = 1MHz, VBW = 10 Hz, Sweep: Auto.
4. “ * ”, means this data is the worst emission level.
5. Measurement Level = Reading Level + Correct Factor.
6. The average measurement was not performed when the peak measured data under the limit of average detection.

Site : CB1	Time : 2015/07/28 - 21:50
Limit : FCC_SpartC_15.247_H_03M_AV	Margin : 6
Probe : CB1_FCC_EFS_1-18G_H2 - HORIZONTAL	Power : AC 120 V / 60Hz
EUT : ASUS SRT-AC1900 Wireless Smart Router	Note : Mode 1: Tx- AUX Antenna (AD891M21) 802.11b_2437MHz

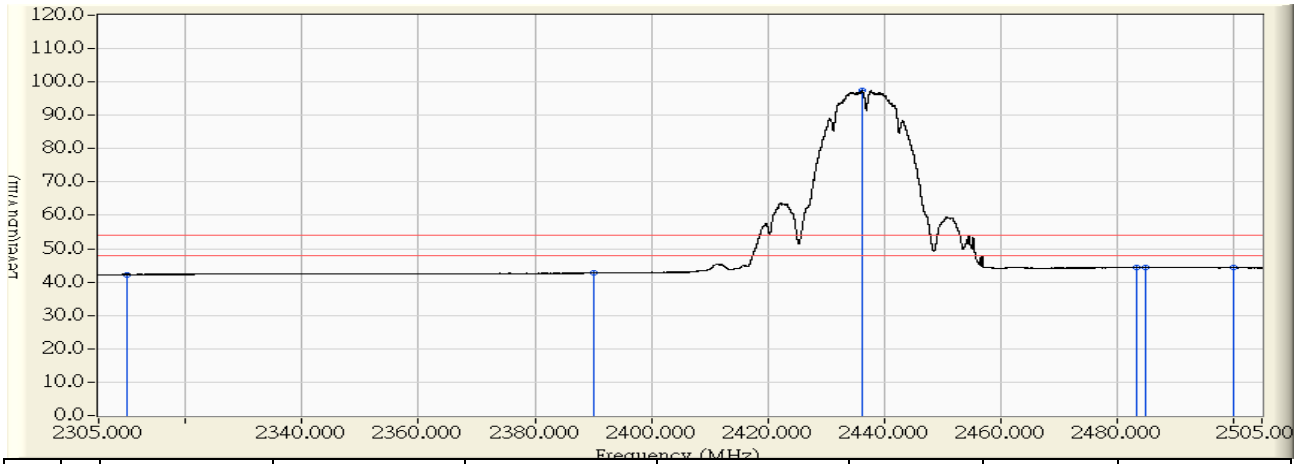

	Frequency (MHz)	Correct Factor (dB)	Reading Level (dBuV)	Measure Level (dBuV/m)	Margin (dB)	Limit (dBuV/m)	Detector Type
1	2310.000	28.130	14.133	42.263	-11.737	54.000	AVERAGE
2	2390.000	28.933	13.803	42.736	-11.264	54.000	AVERAGE
3	* 2436.221	29.397	67.981	97.378	43.378	54.000	AVERAGE
4	2483.500	29.829	14.432	44.261	-9.739	54.000	AVERAGE
5	2484.876	29.830	14.513	44.343	-9.657	54.000	AVERAGE
6	2500.000	29.826	14.516	44.341	-9.659	54.000	AVERAGE

Note:

1. All readings above 1GHz are performed with peak and/or average measurements as necessary.
2. Peak measurements: RBW = 1MHz, VBW = 3 MHz, Sweep: Auto.
3. Average measurements: RBW = 1MHz, VBW = 10 Hz, Sweep: Auto.
4. “ * ”, means this data is the worst emission level.
5. Measurement Level = Reading Level + Correct Factor.
6. The average measurement was not performed when the peak measured data under the limit of average detection.

Site : CB1	Time : 2015/07/28 - 22:01
Limit : FCC_SpartC_15.247_H_03M_PK	Margin : 6
Probe : CB1_FCC_EFS_1-18G_H2 - VERTICAL	Power : AC 120 V / 60Hz
EUT : ASUS SRT-AC1900 Wireless Smart Router	Note : Mode 1: Tx- AUX Antenna (AD891M21) 802.11b_2437MHz

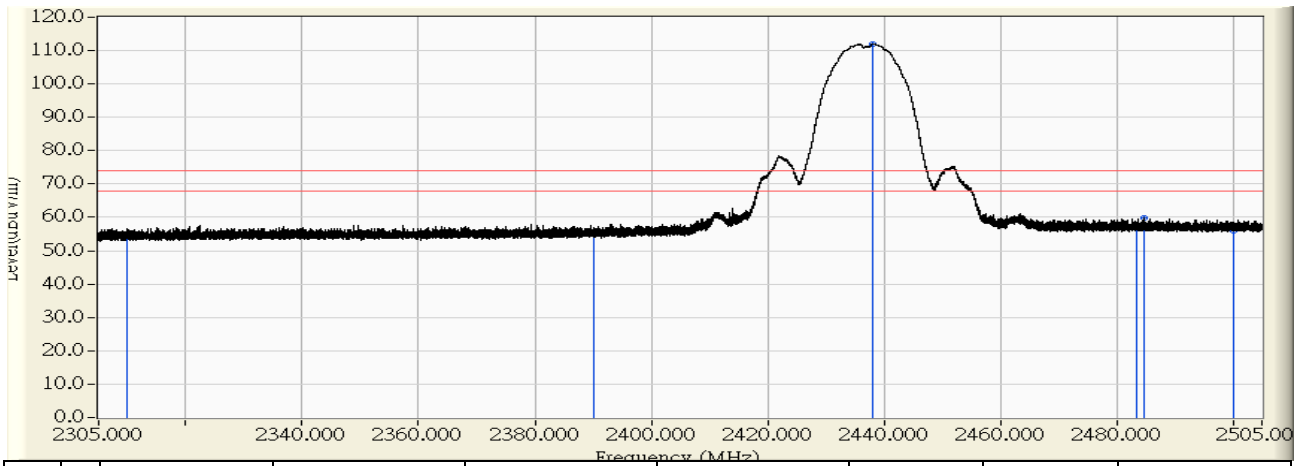

	Frequency (MHz)	Correct Factor (dB)	Reading Level (dBuV)	Measure Level (dBuV/m)	Margin (dB)	Limit (dBuV/m)	Detector Type
1	2310.000	28.784	25.646	54.430	-19.570	74.000	PEAK
2	2390.000	29.747	25.853	55.600	-18.400	74.000	PEAK
3	* 2438.052	30.326	81.660	111.986	37.986	74.000	PEAK
4	2483.500	30.830	26.232	57.062	-16.938	74.000	PEAK
5	2484.782	30.833	28.926	59.759	-14.241	74.000	PEAK
6	2500.000	30.860	25.101	55.960	-18.040	74.000	PEAK

Note:

1. All readings above 1GHz are performed with peak and/or average measurements as necessary.
2. Peak measurements: RBW = 1MHz, VBW = 3 MHz, Sweep: Auto.
3. Average measurements: RBW = 1MHz, VBW = 10 Hz, Sweep: Auto.
4. " * ", means this data is the worst emission level.
5. Measurement Level = Reading Level + Correct Factor.
6. The average measurement was not performed when the peak measured data under the limit of average detection.

Site : CB1	Time : 2015/07/28 - 22:03
Limit : FCC_SpartC_15.247_H_03M_AV	Margin : 6
Probe : CB1_FCC_EFS_1-18G_H2 - VERTICAL	Power : AC 120 V / 60Hz
EUT : ASUS SRT-AC1900 Wireless Smart Router	Note : Mode 1: Tx- AUX Antenna (AD891M21) 802.11b_2437MHz

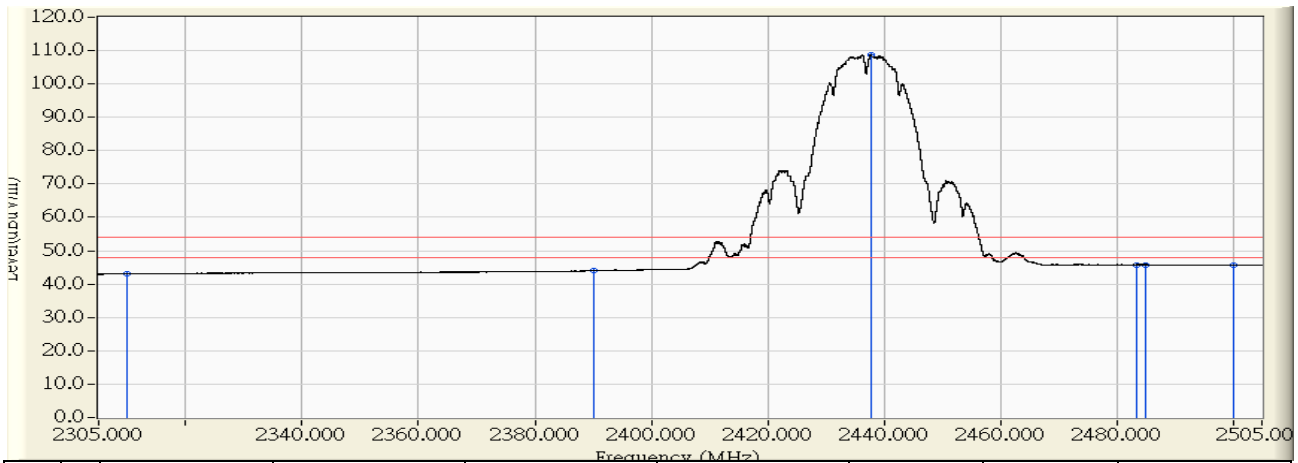

	Frequency (MHz)	Correct Factor (dB)	Reading Level (dBuV)	Measure Level (dBuV/m)	Margin (dB)	Limit (dBuV/m)	Detector Type
1	2310.000	28.784	14.313	43.097	-10.903	54.000	AVERAGE
2	2390.000	29.747	14.286	44.033	-9.967	54.000	AVERAGE
3	* 2437.746	30.323	78.349	108.671	54.671	54.000	AVERAGE
4	2483.500	30.830	14.961	45.791	-8.209	54.000	AVERAGE
5	2484.876	30.833	14.995	45.828	-8.172	54.000	AVERAGE
6	2500.000	30.860	14.849	45.708	-8.292	54.000	AVERAGE

Note:

1. All readings above 1GHz are performed with peak and/or average measurements as necessary.
2. Peak measurements: RBW = 1MHz, VBW = 3 MHz, Sweep: Auto.
3. Average measurements: RBW = 1MHz, VBW = 10 Hz, Sweep: Auto.
4. “ * ”, means this data is the worst emission level.
5. Measurement Level = Reading Level + Correct Factor.
6. The average measurement was not performed when the peak measured data under the limit of average detection.

Site : CB1	Time : 2015/07/28 - 22:11
Limit : FCC_SpartC_15.247_H_03M_PK	Margin : 6
Probe : CB1_FCC_EFS_1-18G_H2 - HORIZONTAL	Power : AC 120 V / 60Hz
EUT : ASUS SRT-AC1900 Wireless Smart Router	Note : Mode 1: Tx- AUX Antenna (AD891M21) 802.11b_2462MHz

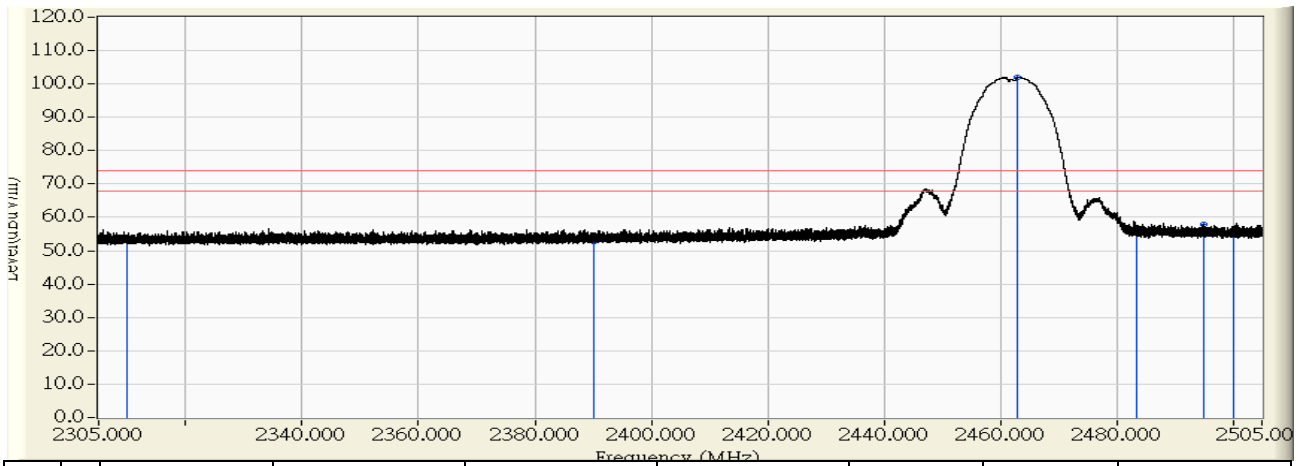

	Frequency (MHz)	Correct Factor (dB)	Reading Level (dBuV)	Measure Level (dBuV/m)	Margin (dB)	Limit (dBuV/m)	Detector Type
1	2310.000	28.130	24.993	53.123	-20.877	74.000	PEAK
2	2390.000	28.933	23.797	52.730	-21.270	74.000	PEAK
3	* 2463.070	29.667	72.348	102.015	28.015	74.000	PEAK
4	2483.500	29.829	25.774	55.603	-18.397	74.000	PEAK
5	2495.106	29.835	28.076	57.911	-16.089	74.000	PEAK
6	2500.000	29.826	25.956	55.781	-18.219	74.000	PEAK

Note:

1. All readings above 1GHz are performed with peak and/or average measurements as necessary.
2. Peak measurements: RBW = 1MHz, VBW = 3 MHz, Sweep: Auto.
3. Average measurements: RBW = 1MHz, VBW = 10 Hz, Sweep: Auto.
4. “ * ”, means this data is the worst emission level.
5. Measurement Level = Reading Level + Correct Factor.
6. The average measurement was not performed when the peak measured data under the limit of average detection.

Site : CB1	Time : 2015/07/28 - 22:13
Limit : FCC_SpartC_15.247_H_03M_AV	Margin : 6
Probe : CB1_FCC_EFS_1-18G_H2 - HORIZONTAL	Power : AC 120 V / 60Hz
EUT : ASUS SRT-AC1900 Wireless Smart Router	Note : Mode 1: Tx- AUX Antenna (AD891M21) 802.11b_2462MHz

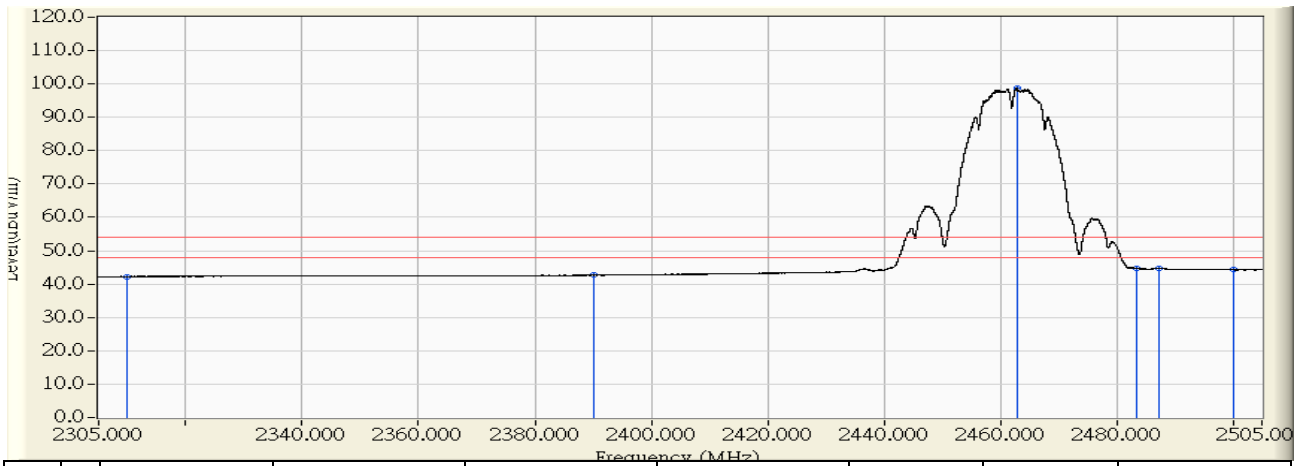

	Frequency (MHz)	Correct Factor (dB)	Reading Level (dBuV)	Measure Level (dBuV/m)	Margin (dB)	Limit (dBuV/m)	Detector Type
1	2310.000	28.130	14.075	42.205	-11.795	54.000	AVERAGE
2	2390.000	28.933	13.763	42.696	-11.304	54.000	AVERAGE
3	* 2462.826	29.664	68.944	98.608	44.608	54.000	AVERAGE
4	2483.500	29.829	14.891	44.720	-9.280	54.000	AVERAGE
5	2487.238	29.831	14.920	44.751	-9.249	54.000	AVERAGE
6	2500.000	29.826	14.458	44.283	-9.717	54.000	AVERAGE

Note:

1. All readings above 1GHz are performed with peak and/or average measurements as necessary.
2. Peak measurements: RBW = 1MHz, VBW = 3 MHz, Sweep: Auto.
3. Average measurements: RBW = 1MHz, VBW = 10 Hz, Sweep: Auto.
4. “ * ”, means this data is the worst emission level.
5. Measurement Level = Reading Level + Correct Factor.
6. The average measurement was not performed when the peak measured data under the limit of average detection.

Site : CB1	Time : 2015/07/28 - 22:19
Limit : FCC_SpartC_15.247_H_03M_PK	Margin : 6
Probe : CB1_FCC_EFS_1-18G_H2 - VERTICAL	Power : AC 120 V / 60Hz
EUT : ASUS SRT-AC1900 Wireless Smart Router	Note : Mode 1: Tx- AUX Antenna (AD891M21) 802.11b_2462MHz

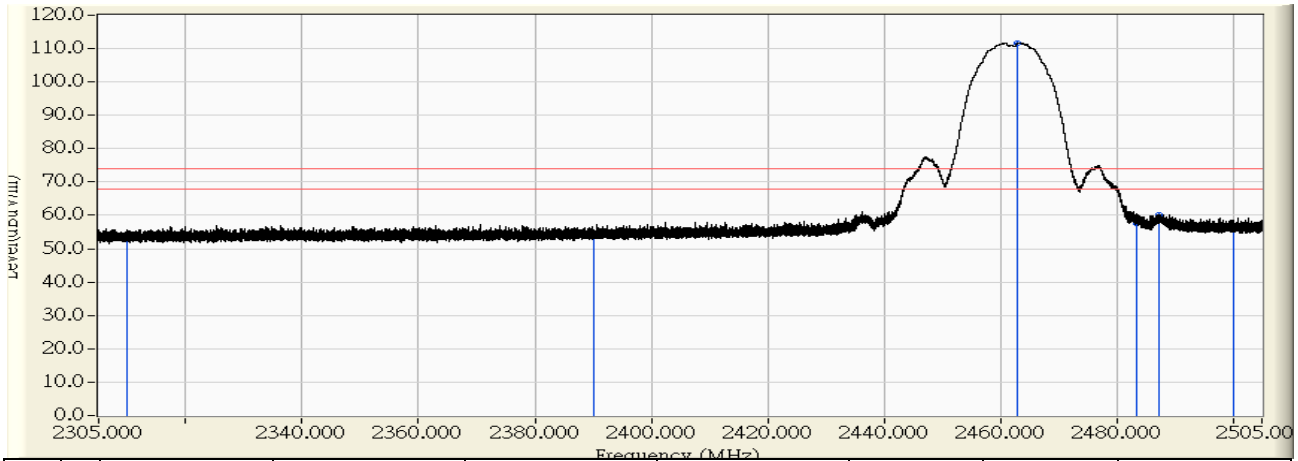

	Frequency (MHz)	Correct Factor (dB)	Reading Level (dBuV)	Measure Level (dBuV/m)	Margin (dB)	Limit (dBuV/m)	Detector Type
1	2310.000	28.784	25.039	53.823	-20.177	74.000	PEAK
2	2390.000	29.747	23.994	53.741	-20.259	74.000	PEAK
3	* 2463.064	30.627	81.119	111.746	37.746	74.000	PEAK
4	2483.500	30.830	26.745	57.575	-16.425	74.000	PEAK
5	2487.238	30.839	29.423	60.262	-13.738	74.000	PEAK
6	2500.000	30.860	26.150	57.009	-16.991	74.000	PEAK

Note:

1. All readings above 1GHz are performed with peak and/or average measurements as necessary.
2. Peak measurements: RBW = 1MHz, VBW = 3 MHz, Sweep: Auto.
3. Average measurements: RBW = 1MHz, VBW = 10 Hz, Sweep: Auto.
4. “ * ”, means this data is the worst emission level.
5. Measurement Level = Reading Level + Correct Factor.
6. The average measurement was not performed when the peak measured data under the limit of average detection.

Site : CB1	Time : 2015/07/28 - 22:20
Limit : FCC_SpartC_15.247_H_03M_AV	Margin : 6
Probe : CB1_FCC_EFS_1-18G_H2 - VERTICAL	Power : AC 120 V / 60Hz
EUT : ASUS SRT-AC1900 Wireless Smart Router	Note : Mode 1: Tx- AUX Antenna (AD891M21) 802.11b_2462MHz

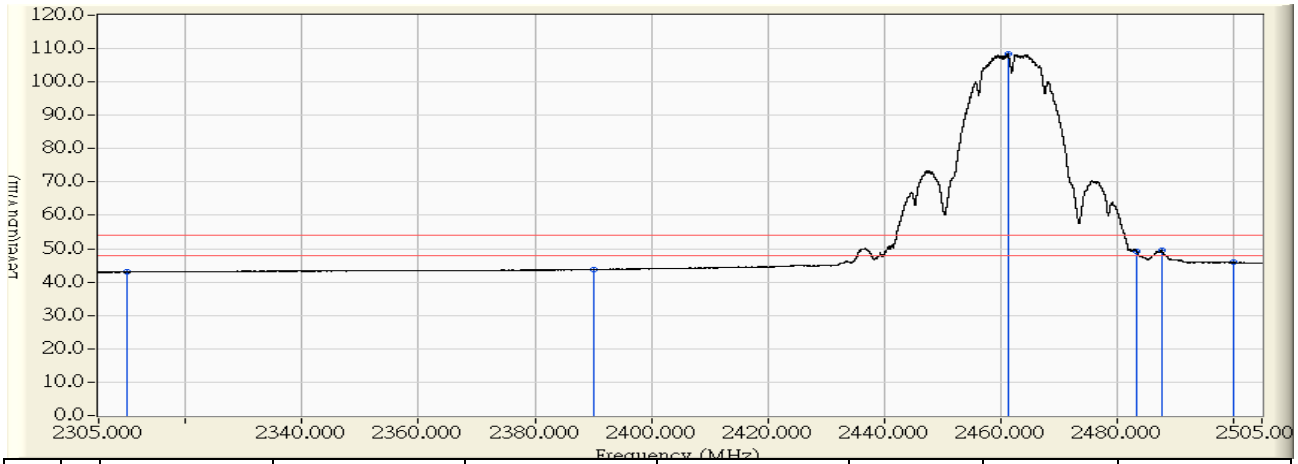

	Frequency (MHz)	Correct Factor (dB)	Reading Level (dBuV)	Measure Level (dBuV/m)	Margin (dB)	Limit (dBuV/m)	Detector Type
1	2310.000	28.784	14.181	42.965	-11.035	54.000	AVERAGE
2	2390.000	29.747	14.009	43.756	-10.244	54.000	AVERAGE
3	* 2461.308	30.606	77.728	108.334	54.334	54.000	AVERAGE
4	2483.500	30.830	18.311	49.141	-4.859	54.000	AVERAGE
5	2487.694	30.840	18.588	49.428	-4.572	54.000	AVERAGE
6	2500.000	30.860	15.034	45.893	-8.107	54.000	AVERAGE

Note:

1. All readings above 1GHz are performed with peak and/or average measurements as necessary.
2. Peak measurements: RBW = 1MHz, VBW = 3 MHz, Sweep: Auto.
3. Average measurements: RBW = 1MHz, VBW = 10 Hz, Sweep: Auto.
4. “ * ”, means this data is the worst emission level.
5. Measurement Level = Reading Level + Correct Factor.
6. The average measurement was not performed when the peak measured data under the limit of average detection.

Site : CB1	Time : 2015/07/28 - 23:08
Limit : FCC_SpartC_15.247_H_03M_PK	Margin : 6
Probe : CB1_FCC_EFS_1-18G_H2 - HORIZONTAL	Power : AC 120 V / 60Hz
EUT : ASUS SRT-AC1900 Wireless Smart Router	Note : Mode 1: Tx- AUX Antenna (AD891M21) 802.11g_2412MHz

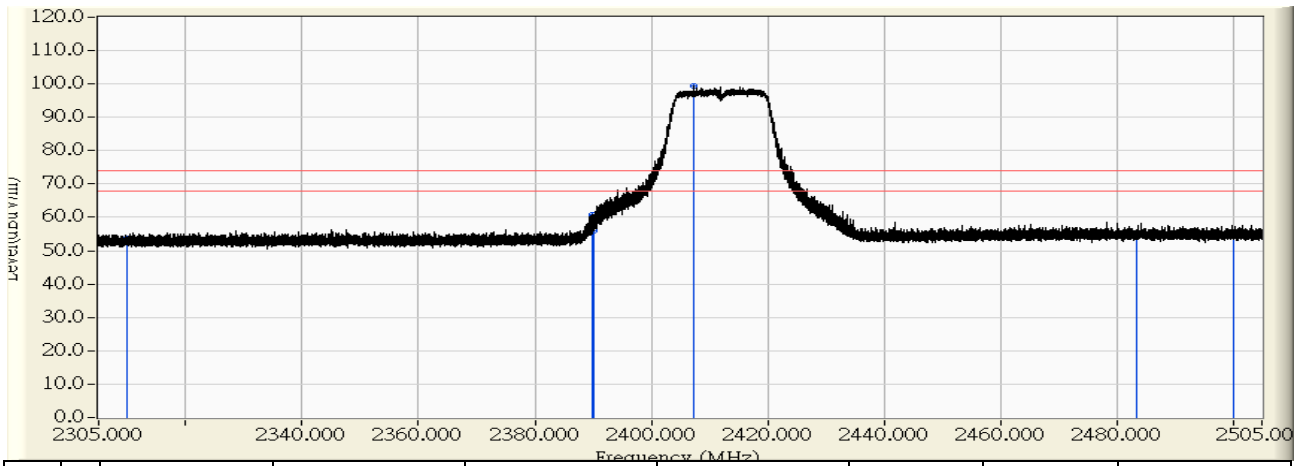

	Frequency (MHz)	Correct Factor (dB)	Reading Level (dBuV)	Measure Level (dBuV/m)	Margin (dB)	Limit (dBuV/m)	Detector Type
1	2310.000	28.130	25.688	53.818	-20.182	74.000	PEAK
2	2389.779	28.931	31.905	60.836	-13.164	74.000	PEAK
3	2390.000	28.933	27.137	56.070	-17.930	74.000	PEAK
4	* 2407.384	29.108	70.236	99.344	25.344	74.000	PEAK
5	2483.500	29.829	24.595	54.424	-19.576	74.000	PEAK
6	2500.000	29.826	24.819	54.644	-19.356	74.000	PEAK

Note:

1. All readings above 1GHz are performed with peak and/or average measurements as necessary.
2. Peak measurements: RBW = 1MHz, VBW = 3 MHz, Sweep: Auto.
3. Average measurements: RBW = 1MHz, VBW = 10 Hz, Sweep: Auto.
4. " * ", means this data is the worst emission level.
5. Measurement Level = Reading Level + Correct Factor.
6. The average measurement was not performed when the peak measured data under the limit of average detection.

Site : CB1	Time : 2015/07/28 - 23:11
Limit : FCC_SpartC_15.247_H_03M_AV	Margin : 6
Probe : CB1_FCC_EFS_1-18G_H2 - HORIZONTAL	Power : AC 120 V / 60Hz
EUT : ASUS SRT-AC1900 Wireless Smart Router	Note : Mode 1: Tx- AUX Antenna (AD891M21) 802.11g_2412MHz

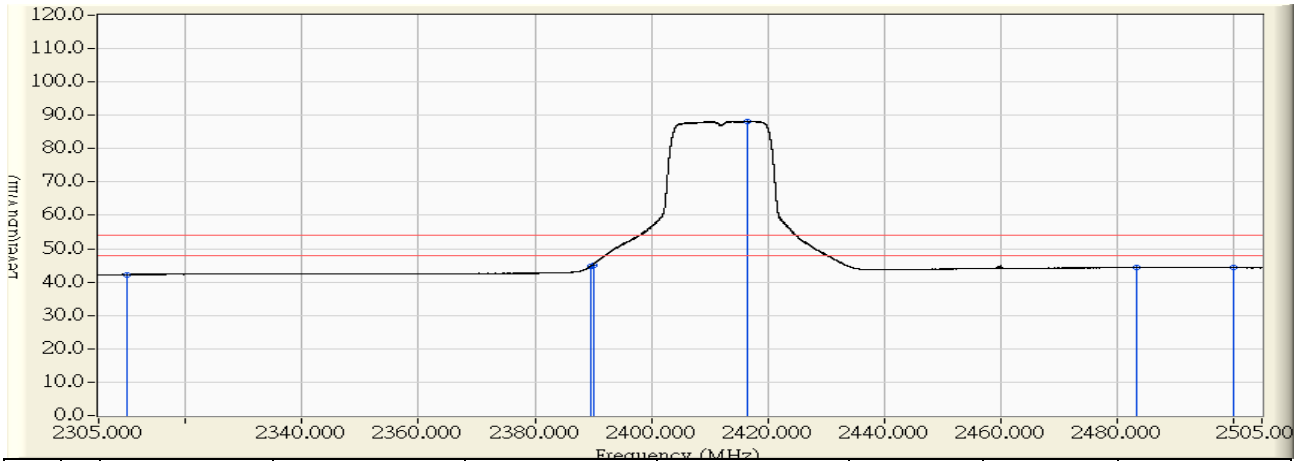

	Frequency (MHz)	Correct Factor (dB)	Reading Level (dBuV)	Measure Level (dBuV/m)	Margin (dB)	Limit (dBuV/m)	Detector Type
1	2310.000	28.130	14.145	42.275	-11.725	54.000	AVERAGE
2	2389.579	28.929	15.823	44.752	-9.248	54.000	AVERAGE
3	2390.000	28.933	16.206	45.139	-8.861	54.000	AVERAGE
4	* 2416.515	29.199	59.064	88.263	34.263	54.000	AVERAGE
5	2483.500	29.829	14.503	44.332	-9.668	54.000	AVERAGE
6	2500.000	29.826	14.450	44.275	-9.725	54.000	AVERAGE

Note:

1. All readings above 1GHz are performed with peak and/or average measurements as necessary.
2. Peak measurements: RBW = 1MHz, VBW = 3 MHz, Sweep: Auto.
3. Average measurements: RBW = 1MHz, VBW = 10 Hz, Sweep: Auto.
4. " * ", means this data is the worst emission level.
5. Measurement Level = Reading Level + Correct Factor.
6. The average measurement was not performed when the peak measured data under the limit of average detection.

Site : CB1	Time : 2015/07/28 - 22:30
Limit : FCC_SpartC_15.247_H_03M_PK	Margin : 6
Probe : CB1_FCC_EFS_1-18G_H2 - VERTICAL	Power : AC 120 V / 60Hz
EUT : ASUS SRT-AC1900 Wireless Smart Router	Note : Mode 1: Tx- AUX Antenna (AD891M21) 802.11g_2412MHz

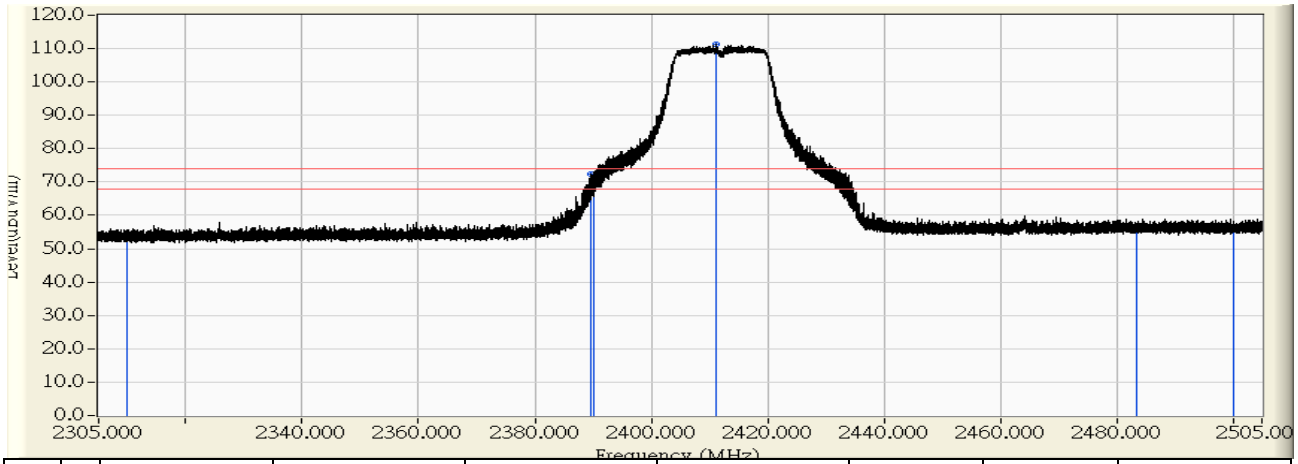

	Frequency (MHz)	Correct Factor (dB)	Reading Level (dBuV)	Measure Level (dBuV/m)	Margin (dB)	Limit (dBuV/m)	Detector Type
1	2310.000	28.784	24.171	52.955	-21.045	74.000	PEAK
2	2389.716	29.744	42.528	72.272	-1.728	74.000	PEAK
3	2390.000	29.747	40.814	70.561	-3.439	74.000	PEAK
4	* 2411.153	30.001	81.371	111.373	37.373	74.000	PEAK
5	2483.500	30.830	25.465	56.295	-17.705	74.000	PEAK
6	2500.000	30.860	25.113	55.972	-18.028	74.000	PEAK

Note:

1. All readings above 1GHz are performed with peak and/or average measurements as necessary.
2. Peak measurements: RBW = 1MHz, VBW = 3 MHz, Sweep: Auto.
3. Average measurements: RBW = 1MHz, VBW = 10 Hz, Sweep: Auto.
4. “ * ”, means this data is the worst emission level.
5. Measurement Level = Reading Level + Correct Factor.
6. The average measurement was not performed when the peak measured data under the limit of average detection.

Site : CB1	Time : 2015/07/28 - 22:28
Limit : FCC_SpartC_15.247_H_03M_AV	Margin : 6
Probe : CB1_FCC_EFS_1-18G_H2 - VERTICAL	Power : AC 120 V / 60Hz
EUT : ASUS SRT-AC1900 Wireless Smart Router	Note : Mode 1: Tx- AUX Antenna (AD891M21) 802.11g_2412MHz

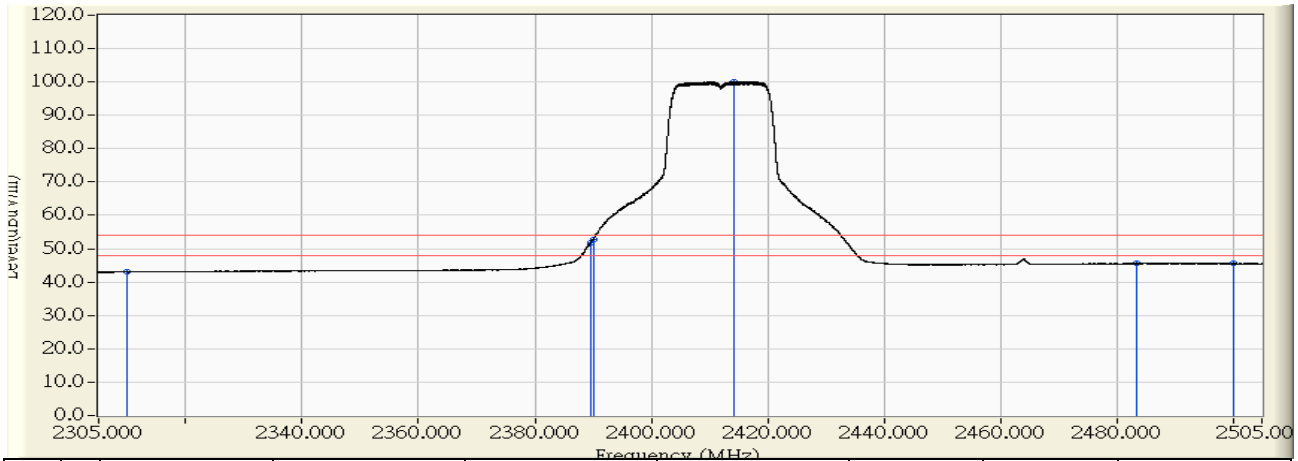

	Frequency (MHz)	Correct Factor (dB)	Reading Level (dBuV)	Measure Level (dBuV/m)	Margin (dB)	Limit (dBuV/m)	Detector Type
1	2310.000	28.784	14.209	42.993	-11.007	54.000	AVERAGE
2	2389.529	29.741	22.015	51.756	-2.244	54.000	AVERAGE
3	2390.000	29.747	23.091	52.838	-1.162	54.000	AVERAGE
4	* 2414.122	30.037	69.976	100.014	46.014	54.000	AVERAGE
5	2483.500	30.830	14.738	45.568	-8.432	54.000	AVERAGE
6	2500.000	30.860	14.691	45.550	-8.450	54.000	AVERAGE

Note:

1. All readings above 1GHz are performed with peak and/or average measurements as necessary.
2. Peak measurements: RBW = 1MHz, VBW = 3 MHz, Sweep: Auto.
3. Average measurements: RBW = 1MHz, VBW = 10 Hz, Sweep: Auto.
4. “ * ”, means this data is the worst emission level.
5. Measurement Level = Reading Level + Correct Factor.
6. The average measurement was not performed when the peak measured data under the limit of average detection.

Site : CB1	Time : 2015/07/28 - 23:26
Limit : FCC_SpartC_15.247_H_03M_PK	Margin : 6
Probe : CB1_FCC_EFS_1-18G_H2 - HORIZONTAL	Power : AC 120 V / 60Hz
EUT : ASUS SRT-AC1900 Wireless Smart Router	Note : Mode 1: Tx- AUX Antenna (AD891M21) 802.11g_2437MHz

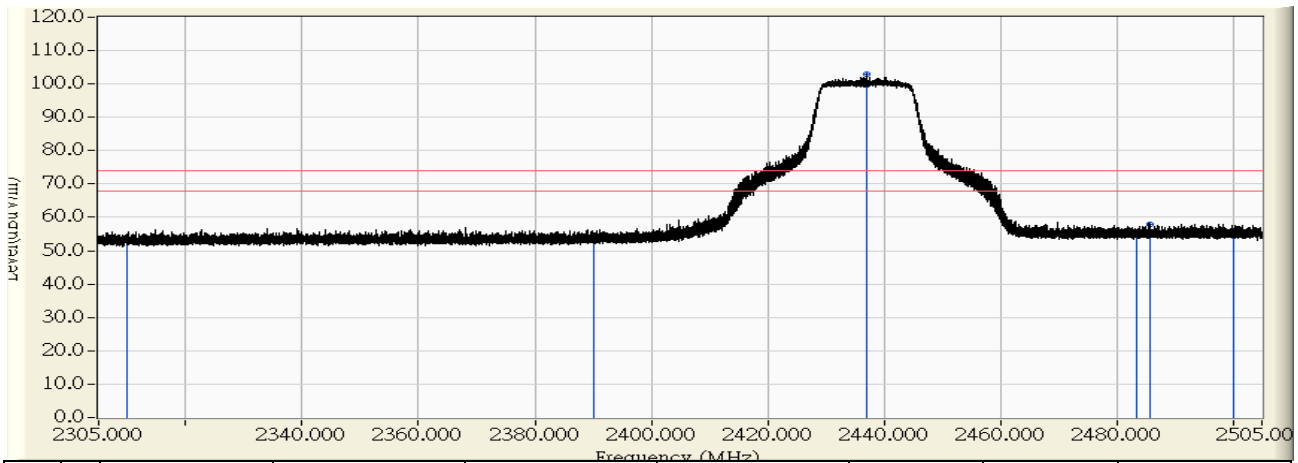

	Frequency (MHz)	Correct Factor (dB)	Reading Level (dBuV)	Measure Level (dBuV/m)	Margin (dB)	Limit (dBuV/m)	Detector Type
1	2310.000	28.130	25.092	53.222	-20.778	74.000	PEAK
2	2390.000	28.933	24.073	53.006	-20.994	74.000	PEAK
3	* 2437.108	29.406	73.476	102.882	28.882	74.000	PEAK
4	2483.500	29.829	25.029	54.858	-19.142	74.000	PEAK
5	2485.682	29.830	28.125	57.955	-16.045	74.000	PEAK
6	2500.000	29.826	24.561	54.386	-19.614	74.000	PEAK

Note:

1. All readings above 1GHz are performed with peak and/or average measurements as necessary.
2. Peak measurements: RBW = 1MHz, VBW = 3 MHz, Sweep: Auto.
3. Average measurements: RBW = 1MHz, VBW = 10 Hz, Sweep: Auto.
4. “ * ”, means this data is the worst emission level.
5. Measurement Level = Reading Level + Correct Factor.
6. The average measurement was not performed when the peak measured data under the limit of average detection.

Site : CB1	Time : 2015/07/28 - 23:28
Limit : FCC_SpartC_15.247_H_03M_AV	Margin : 6
Probe : CB1_FCC_EFS_1-18G_H2 - HORIZONTAL	Power : AC 120 V / 60Hz
EUT : ASUS SRT-AC1900 Wireless Smart Router	Note : Mode 1: Tx- AUX Antenna (AD891M21) 802.11g_2437MHz

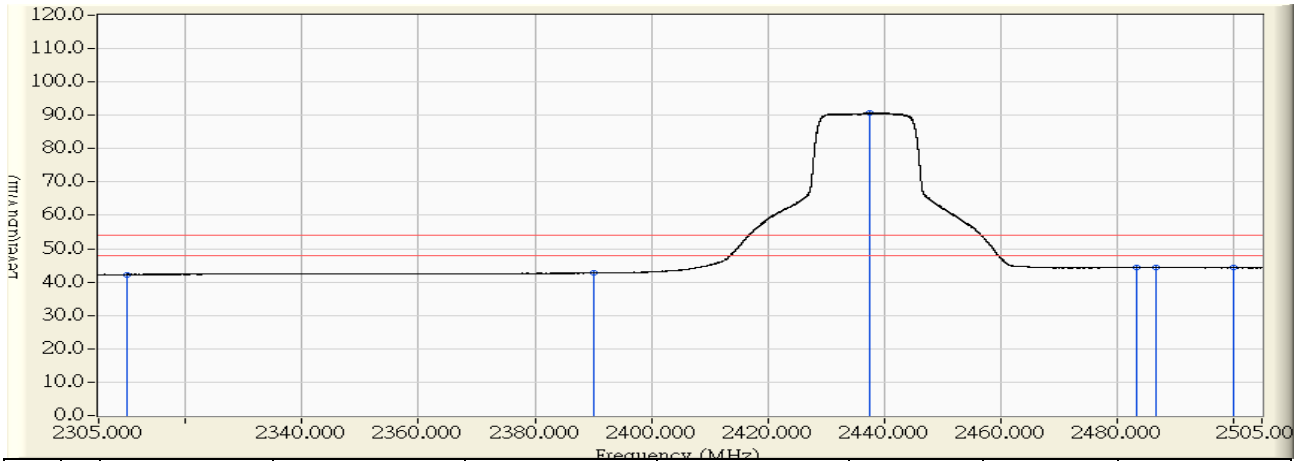

	Frequency (MHz)	Correct Factor (dB)	Reading Level (dBuV)	Measure Level (dBuV/m)	Margin (dB)	Limit (dBuV/m)	Detector Type
1	2310.000	28.130	14.103	42.233	-11.767	54.000	AVERAGE
2	2390.000	28.933	13.727	42.660	-11.340	54.000	AVERAGE
3	* 2437.465	29.409	61.334	90.744	36.744	54.000	AVERAGE
4	2483.500	29.829	14.457	44.286	-9.714	54.000	AVERAGE
5	2486.669	29.831	14.457	44.288	-9.712	54.000	AVERAGE
6	2500.000	29.826	14.475	44.300	-9.700	54.000	AVERAGE

Note:

1. All readings above 1GHz are performed with peak and/or average measurements as necessary.
2. Peak measurements: RBW = 1MHz, VBW = 3 MHz, Sweep: Auto.
3. Average measurements: RBW = 1MHz, VBW = 10 Hz, Sweep: Auto.
4. “ * ”, means this data is the worst emission level.
5. Measurement Level = Reading Level + Correct Factor.
6. The average measurement was not performed when the peak measured data under the limit of average detection.

Site : CB1	Time : 2015/07/28 - 23:19
Limit : FCC_SpartC_15.247_H_03M_PK	Margin : 6
Probe : CB1_FCC_EFS_1-18G_H2 - VERTICAL	Power : AC 120 V / 60Hz
EUT : ASUS SRT-AC1900 Wireless Smart Router	Note : Mode 1: Tx- AUX Antenna (AD891M21) 802.11g_2437MHz

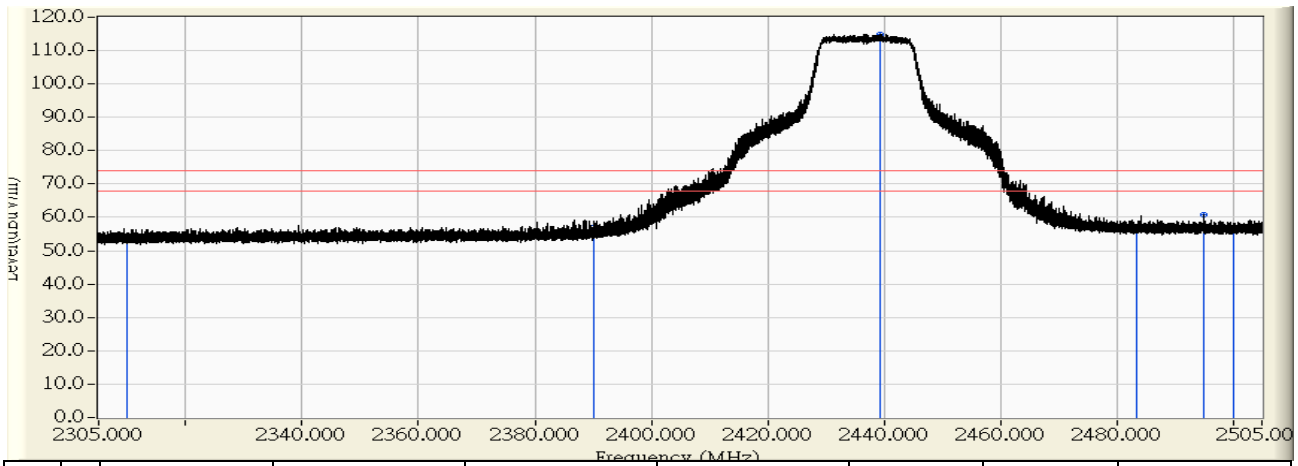

	Frequency (MHz)	Correct Factor (dB)	Reading Level (dBuV)	Measure Level (dBuV/m)	Margin (dB)	Limit (dBuV/m)	Detector Type
1	2310.000	28.784	24.620	53.404	-20.596	74.000	PEAK
2	2390.000	29.747	27.068	56.815	-17.185	74.000	PEAK
3	* 2439.446	30.342	84.621	114.964	40.964	74.000	PEAK
4	2483.500	30.830	25.166	55.996	-18.004	74.000	PEAK
5	2494.944	30.858	30.015	60.874	-13.126	74.000	PEAK
6	2500.000	30.860	25.580	56.439	-17.561	74.000	PEAK

Note:

1. All readings above 1GHz are performed with peak and/or average measurements as necessary.
2. Peak measurements: RBW = 1MHz, VBW = 3 MHz, Sweep: Auto.
3. Average measurements: RBW = 1MHz, VBW = 10 Hz, Sweep: Auto.
4. “ * ”, means this data is the worst emission level.
5. Measurement Level = Reading Level + Correct Factor.
6. The average measurement was not performed when the peak measured data under the limit of average detection.

Site : CB1	Time : 2015/07/28 - 23:18
Limit : FCC_SpartC_15.247_H_03M_AV	Margin : 6
Probe : CB1_FCC_EFS_1-18G_H2 - VERTICAL	Power : AC 120 V / 60Hz
EUT : ASUS SRT-AC1900 Wireless Smart Router	Note : Mode 1: Tx- AUX Antenna (AD891M21) 802.11g_2437MHz

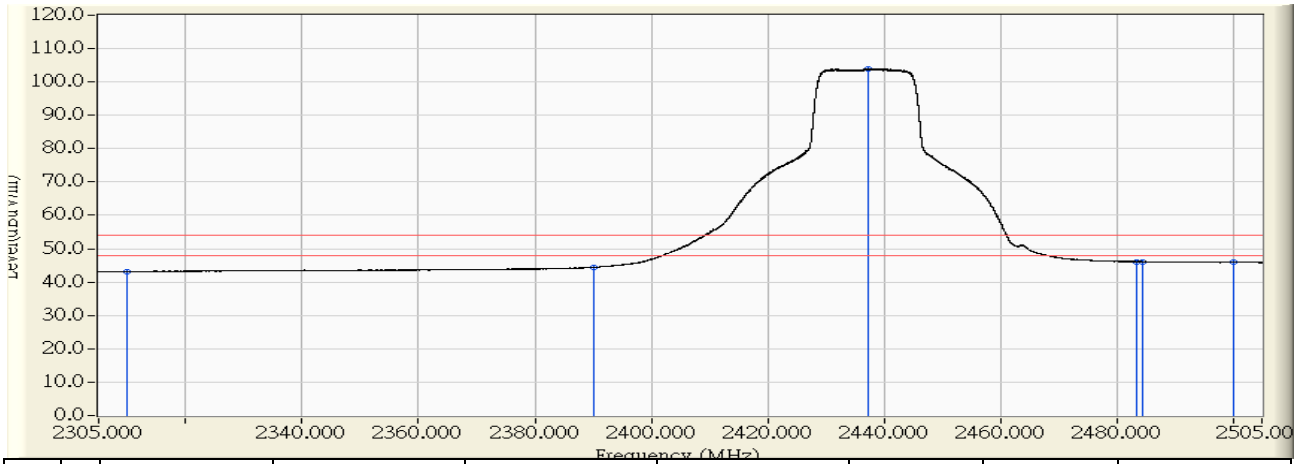

	Frequency (MHz)	Correct Factor (dB)	Reading Level (dBuV)	Measure Level (dBuV/m)	Margin (dB)	Limit (dBuV/m)	Detector Type
1	2310.000	28.784	14.382	43.166	-10.834	54.000	AVERAGE
2	2390.000	29.747	14.660	44.407	-9.593	54.000	AVERAGE
3	* 2437.377	30.317	73.576	103.894	49.894	54.000	AVERAGE
4	2483.500	30.830	15.294	46.124	-7.876	54.000	AVERAGE
5	2484.363	30.832	15.304	46.136	-7.864	54.000	AVERAGE
6	2500.000	30.860	15.089	45.948	-8.052	54.000	AVERAGE

Note:

1. All readings above 1GHz are performed with peak and/or average measurements as necessary.
2. Peak measurements: RBW = 1MHz, VBW = 3 MHz, Sweep: Auto.
3. Average measurements: RBW = 1MHz, VBW = 10 Hz, Sweep: Auto.
4. “ * ”, means this data is the worst emission level.
5. Measurement Level = Reading Level + Correct Factor.
6. The average measurement was not performed when the peak measured data under the limit of average detection.

Site : CB1	Time : 2015/07/28 - 23:41
Limit : FCC_SpartC_15.247_H_03M_PK	Margin : 6
Probe : CB1_FCC_EFS_1-18G_H2 - HORIZONTAL	Power : AC 120 V / 60Hz
EUT : ASUS SRT-AC1900 Wireless Smart Router	Note : Mode 1: Tx- AUX Antenna (AD891M21) 802.11g_2462MHz

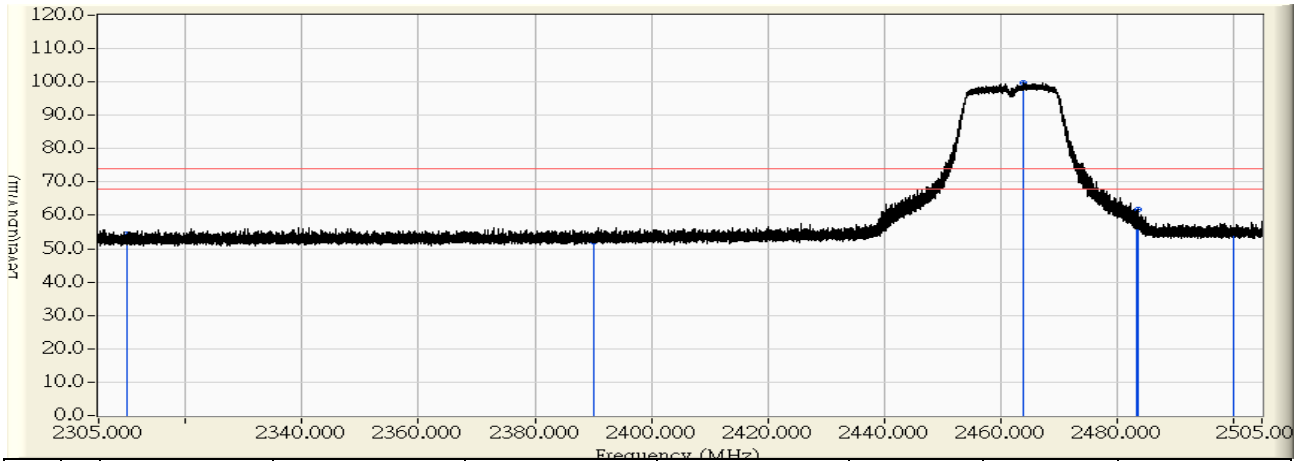

	Frequency (MHz)	Correct Factor (dB)	Reading Level (dBuV)	Measure Level (dBuV/m)	Margin (dB)	Limit (dBuV/m)	Detector Type
1	2310.000	28.130	26.166	54.296	-19.704	74.000	PEAK
2	2390.000	28.933	23.305	52.238	-21.762	74.000	PEAK
3	* 2464.070	29.677	70.165	99.842	25.842	74.000	PEAK
4	2483.500	29.829	27.763	57.592	-16.408	74.000	PEAK
5	2483.763	29.830	31.835	61.664	-12.336	74.000	PEAK
6	2500.000	29.826	24.690	54.515	-19.485	74.000	PEAK

Note:

1. All readings above 1GHz are performed with peak and/or average measurements as necessary.
2. Peak measurements: RBW = 1MHz, VBW = 3 MHz, Sweep: Auto.
3. Average measurements: RBW = 1MHz, VBW = 10 Hz, Sweep: Auto.
4. “ * ”, means this data is the worst emission level.
5. Measurement Level = Reading Level + Correct Factor.
6. The average measurement was not performed when the peak measured data under the limit of average detection.

Site : CB1	Time : 2015/07/28 - 23:41
Limit : FCC_SpartC_15.247_H_03M_AV	Margin : 6
Probe : CB1_FCC_EFS_1-18G_H2 - HORIZONTAL	Power : AC 120 V / 60Hz
EUT : ASUS SRT-AC1900 Wireless Smart Router	Note : Mode 1: Tx- AUX Antenna (AD891M21) 802.11g_2462MHz

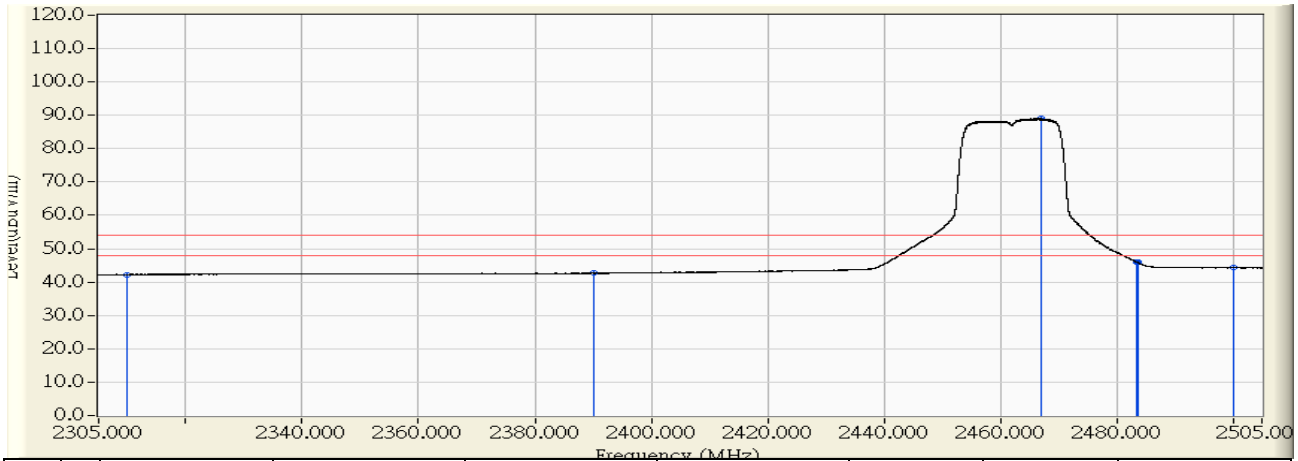

	Frequency (MHz)	Correct Factor (dB)	Reading Level (dBuV)	Measure Level (dBuV/m)	Margin (dB)	Limit (dBuV/m)	Detector Type
1	2310.000	28.130	14.159	42.289	-11.711	54.000	AVERAGE
2	2390.000	28.933	13.724	42.657	-11.343	54.000	AVERAGE
3	* 2466.976	29.706	59.291	88.997	34.997	54.000	AVERAGE
4	2483.500	29.829	16.094	45.923	-8.077	54.000	AVERAGE
5	2483.594	29.829	16.069	45.898	-8.102	54.000	AVERAGE
6	2500.000	29.826	14.498	44.323	-9.677	54.000	AVERAGE

Note:

1. All readings above 1GHz are performed with peak and/or average measurements as necessary.
2. Peak measurements: RBW = 1MHz, VBW = 3 MHz, Sweep: Auto.
3. Average measurements: RBW = 1MHz, VBW = 10 Hz, Sweep: Auto.
4. “ * ”, means this data is the worst emission level.
5. Measurement Level = Reading Level + Correct Factor.
6. The average measurement was not performed when the peak measured data under the limit of average detection.

Site : CB1	Time : 2015/07/28 - 23:36
Limit : FCC_SpartC_15.247_H_03M_PK	Margin : 6
Probe : CB1_FCC_EFS_1-18G_H2 - VERTICAL	Power : AC 120 V / 60Hz
EUT : ASUS SRT-AC1900 Wireless Smart Router	Note : Mode 1: Tx- AUX Antenna (AD891M21) 802.11g_2462MHz

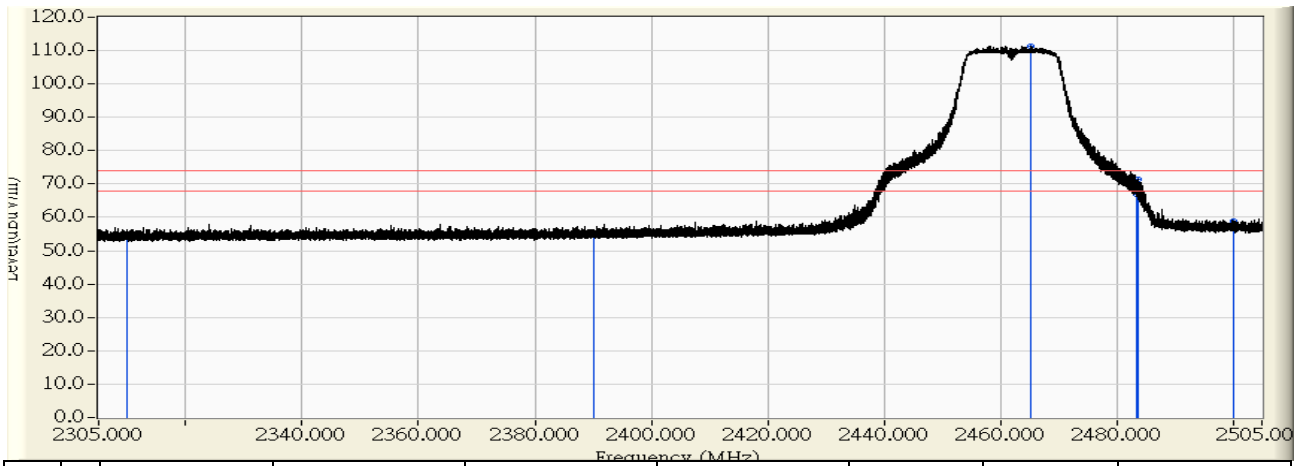

	Frequency (MHz)	Correct Factor (dB)	Reading Level (dBuV)	Measure Level (dBuV/m)	Margin (dB)	Limit (dBuV/m)	Detector Type
1	2310.000	28.784	25.497	54.281	-19.719	74.000	PEAK
2	2390.000	29.747	25.205	54.952	-19.048	74.000	PEAK
3	* 2465.345	30.654	80.791	111.445	37.445	74.000	PEAK
4	2483.500	30.830	35.992	66.822	-7.178	74.000	PEAK
5	2483.713	30.831	40.444	71.275	-2.725	74.000	PEAK
6	2500.000	30.860	27.901	58.760	-15.240	74.000	PEAK

Note:

1. All readings above 1GHz are performed with peak and/or average measurements as necessary.
2. Peak measurements: RBW = 1MHz, VBW = 3 MHz, Sweep: Auto.
3. Average measurements: RBW = 1MHz, VBW = 10 Hz, Sweep: Auto.
4. " * ", means this data is the worst emission level.
5. Measurement Level = Reading Level + Correct Factor.
6. The average measurement was not performed when the peak measured data under the limit of average detection.

Site : CB1	Time : 2015/07/28 - 23:34
Limit : FCC_SpartC_15.247_H_03M_AV	Margin : 6
Probe : CB1_FCC_EFS_1-18G_H2 - VERTICAL	Power : AC 120 V / 60Hz
EUT : ASUS SRT-AC1900 Wireless Smart Router	Note : Mode 1: Tx- AUX Antenna (AD891M21) 802.11g_2462MHz

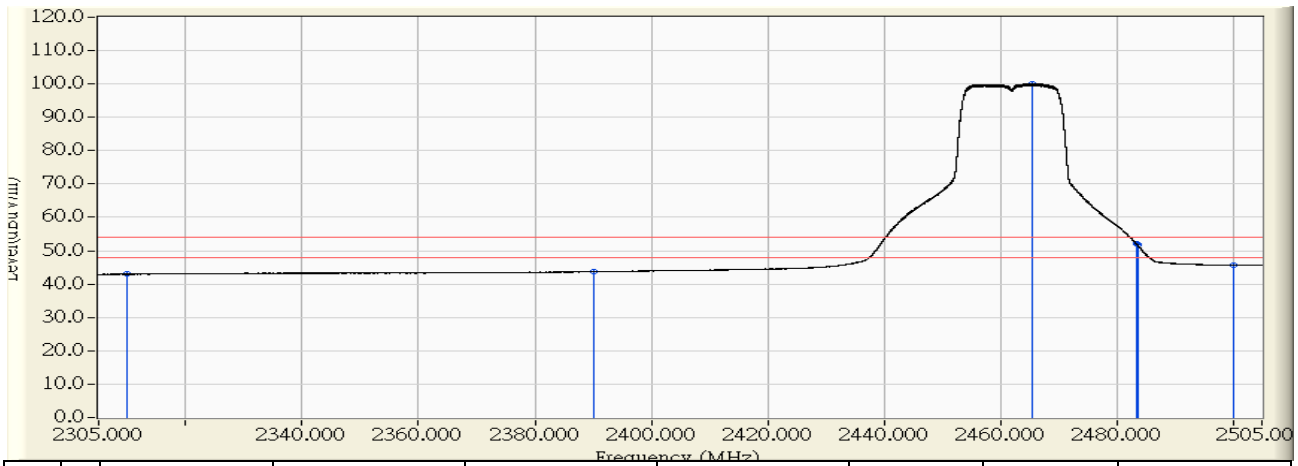

	Frequency (MHz)	Correct Factor (dB)	Reading Level (dBuV)	Measure Level (dBuV/m)	Margin (dB)	Limit (dBuV/m)	Detector Type
1	2310.000	28.784	14.224	43.008	-10.992	54.000	AVERAGE
2	2390.000	29.747	13.991	43.738	-10.262	54.000	AVERAGE
3	* 2465.507	30.656	69.444	100.100	46.100	54.000	AVERAGE
4	2483.500	30.830	21.214	52.044	-1.956	54.000	AVERAGE
5	2483.594	30.831	20.999	51.829	-2.171	54.000	AVERAGE
6	2500.000	30.860	14.831	45.690	-8.310	54.000	AVERAGE

Note:

1. All readings above 1GHz are performed with peak and/or average measurements as necessary.
2. Peak measurements: RBW = 1MHz, VBW = 3 MHz, Sweep: Auto.
3. Average measurements: RBW = 1MHz, VBW = 10 Hz, Sweep: Auto.
4. “ * ”, means this data is the worst emission level.
5. Measurement Level = Reading Level + Correct Factor.
6. The average measurement was not performed when the peak measured data under the limit of average detection.

Site : CB1	Time : 2015/07/29 - 00:18
Limit : FCC_SpartC_15.247_H_03M_PK	Margin : 6
Probe : CB1_FCC_EFS_1-18G_H2 - HORIZONTAL	Power : AC 120 V / 60Hz
EUT : ASUS SRT-AC1900 Wireless Smart Router	Note : Mode 1: Tx- AUX Antenna (AD891M21) 802.11n(20MHz)_2412MHz

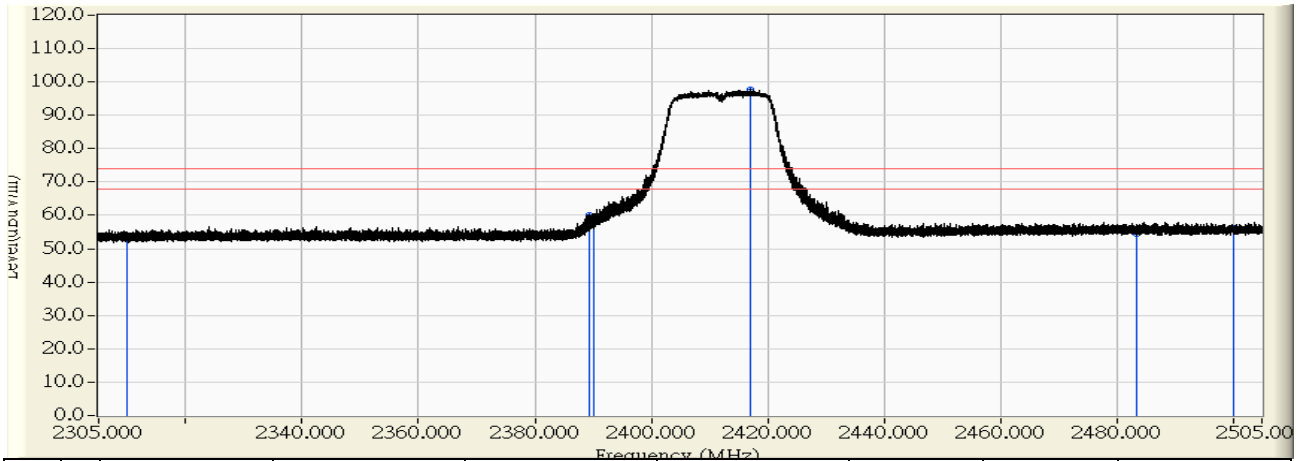

	Frequency (MHz)	Correct Factor (dB)	Reading Level (dBuV)	Measure Level (dBuV/m)	Margin (dB)	Limit (dBuV/m)	Detector Type
1	2310.000	28.130	25.697	53.827	-20.173	74.000	PEAK
2	2389.347	28.927	31.386	60.313	-13.687	74.000	PEAK
3	2390.000	28.933	29.584	58.517	-15.483	74.000	PEAK
4	* 2417.103	29.205	68.469	97.674	23.674	74.000	PEAK
5	2483.500	29.829	24.518	54.347	-19.653	74.000	PEAK
6	2500.000	29.826	26.442	56.267	-17.733	74.000	PEAK

Note:

1. All readings above 1GHz are performed with peak and/or average measurements as necessary.
2. Peak measurements: RBW = 1MHz, VBW = 3 MHz, Sweep: Auto.
3. Average measurements: RBW = 1MHz, VBW = 10 Hz, Sweep: Auto.
4. " * ", means this data is the worst emission level.
5. Measurement Level = Reading Level + Correct Factor.
6. The average measurement was not performed when the peak measured data under the limit of average detection.

Site : CB1	Time : 2015/07/29 - 00:50
Limit : FCC_SpartC_15.247_H_03M_AV	Margin : 6
Probe : CB1_FCC_EFS_1-18G_H2 - HORIZONTAL	Power : AC 120 V / 60Hz
EUT : ASUS SRT-AC1900 Wireless Smart Router	Note : Mode 1: Tx- AUX Antenna (AD891M21) 802.11n(20MHz)_2412MHz

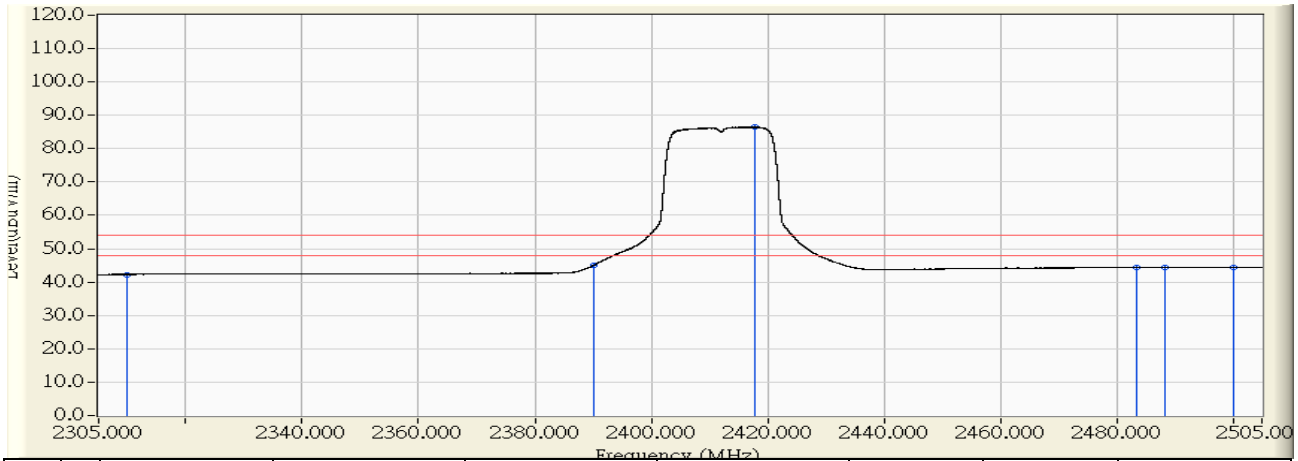

	Frequency (MHz)	Correct Factor (dB)	Reading Level (dBuV)	Measure Level (dBuV/m)	Margin (dB)	Limit (dBuV/m)	Detector Type
1	2310.000	28.130	14.161	42.291	-11.709	54.000	AVERAGE
2	2390.000	28.933	15.981	44.914	-9.086	54.000	AVERAGE
3	* 2417.721	29.212	57.421	86.632	32.632	54.000	AVERAGE
4	2483.500	29.829	14.546	44.375	-9.625	54.000	AVERAGE
5	2488.207	29.832	14.514	44.345	-9.655	54.000	AVERAGE
6	2500.000	29.826	14.494	44.319	-9.681	54.000	AVERAGE

Note:

1. All readings above 1GHz are performed with peak and/or average measurements as necessary.
2. Peak measurements: RBW = 1MHz, VBW = 3 MHz, Sweep: Auto.
3. Average measurements: RBW = 1MHz, VBW = 10 Hz, Sweep: Auto.
4. “ * ”, means this data is the worst emission level.
5. Measurement Level = Reading Level + Correct Factor.
6. The average measurement was not performed when the peak measured data under the limit of average detection.

Site : CB1	Time : 2015/07/29 - 00:13
Limit : FCC_SpartC_15.247_H_03M_PK	Margin : 6
Probe : CB1_FCC_EFS_1-18G_H2 - VERTICAL	Power : AC 120 V / 60Hz
EUT : ASUS SRT-AC1900 Wireless Smart Router	Note : Mode 1: Tx- AUX Antenna (AD891M21) 802.11n(20MHz)_2412MHz

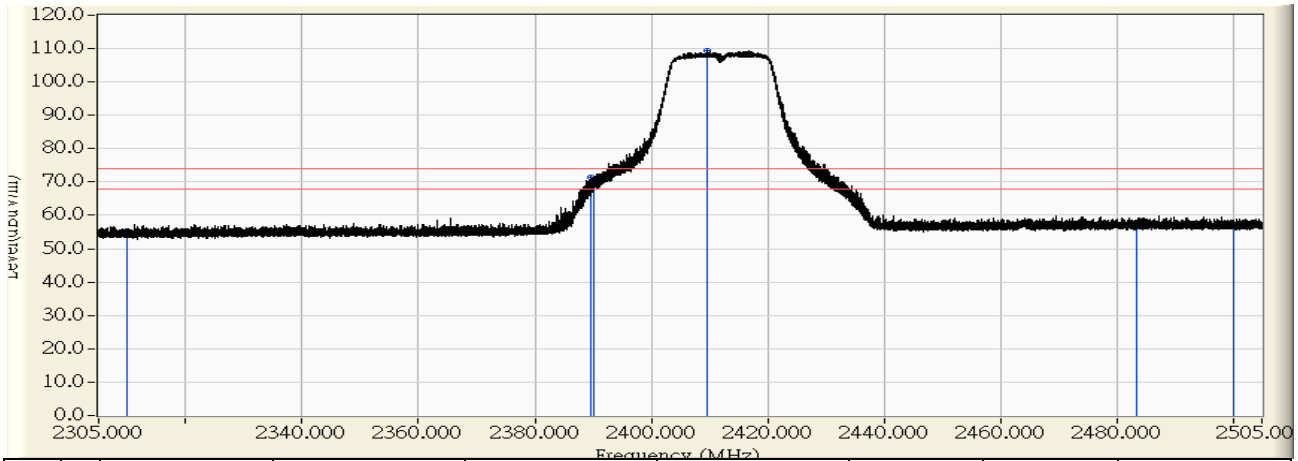

	Frequency (MHz)	Correct Factor (dB)	Reading Level (dBuV)	Measure Level (dBuV/m)	Margin (dB)	Limit (dBuV/m)	Detector Type
1	2310.000	28.784	26.584	55.368	-18.632	74.000	PEAK
2	2389.604	29.742	41.726	71.468	-2.532	74.000	PEAK
3	2390.000	29.747	40.389	70.136	-3.864	74.000	PEAK
4	* 2409.603	29.983	79.556	109.539	35.539	74.000	PEAK
5	2483.500	30.830	25.791	56.621	-17.379	74.000	PEAK
6	2500.000	30.860	26.230	57.089	-16.911	74.000	PEAK

Note:

1. All readings above 1GHz are performed with peak and/or average measurements as necessary.
2. Peak measurements: RBW = 1MHz, VBW = 3 MHz, Sweep: Auto.
3. Average measurements: RBW = 1MHz, VBW = 10 Hz, Sweep: Auto.
4. “ * ”, means this data is the worst emission level.
5. Measurement Level = Reading Level + Correct Factor.
6. The average measurement was not performed when the peak measured data under the limit of average detection.

Site : CB1	Time : 2015/07/29 - 00:11
Limit : FCC_SpartC_15.247_H_03M_AV	Margin : 6
Probe : CB1_FCC_EFS_1-18G_H2 - VERTICAL	Power : AC 120 V / 60Hz
EUT : ASUS SRT-AC1900 Wireless Smart Router	Note : Mode 1: Tx- AUX Antenna (AD891M21) 802.11n(20MHz)_2412MHz

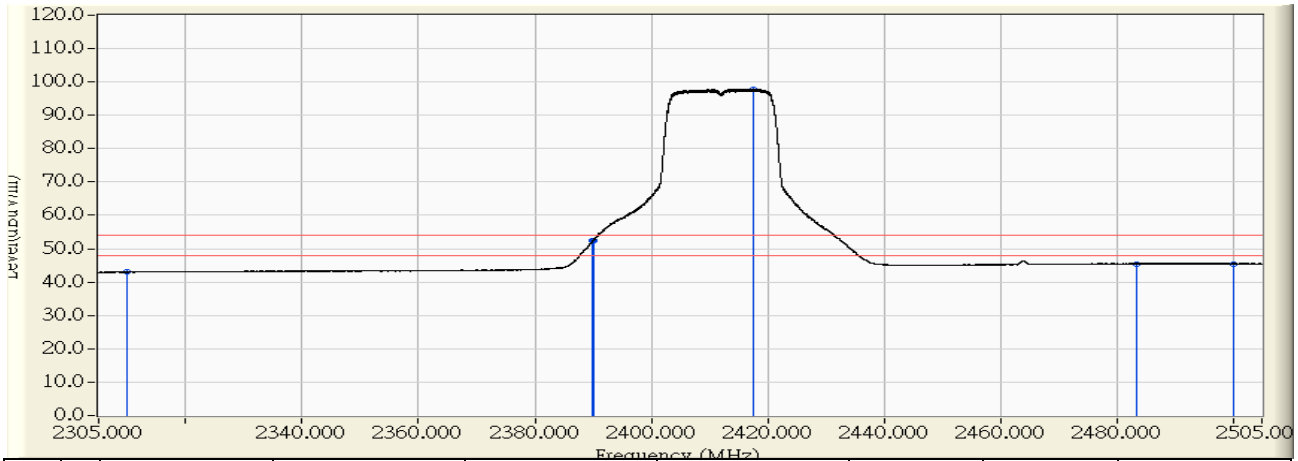

	Frequency (MHz)	Correct Factor (dB)	Reading Level (dBuV)	Measure Level (dBuV/m)	Margin (dB)	Limit (dBuV/m)	Detector Type
1	2310.000	28.784	14.174	42.958	-11.042	54.000	AVERAGE
2	2389.891	29.746	22.543	52.289	-1.711	54.000	AVERAGE
3	2390.000	29.747	22.595	52.342	-1.658	54.000	AVERAGE
4	* 2417.590	30.080	67.819	97.898	43.898	54.000	AVERAGE
5	2483.500	30.830	14.682	45.512	-8.488	54.000	AVERAGE
6	2500.000	30.860	14.647	45.506	-8.494	54.000	AVERAGE

Note:

1. All readings above 1GHz are performed with peak and/or average measurements as necessary.
2. Peak measurements: RBW = 1MHz, VBW = 3 MHz, Sweep: Auto.
3. Average measurements: RBW = 1MHz, VBW = 10 Hz, Sweep: Auto.
4. " * ", means this data is the worst emission level.
5. Measurement Level = Reading Level + Correct Factor.
6. The average measurement was not performed when the peak measured data under the limit of average detection.

Site : CB1	Time : 2015/07/29 - 01:05
Limit : FCC_SpartC_15.247_H_03M_PK	Margin : 6
Probe : CB1_FCC_EFS_1-18G_H2 - HORIZONTAL	Power : AC 120 V / 60Hz
EUT : ASUS SRT-AC1900 Wireless Smart Router	Note : Mode 1: Tx- AUX Antenna (AD891M21) 802.11n(20MHz)_2437MHz

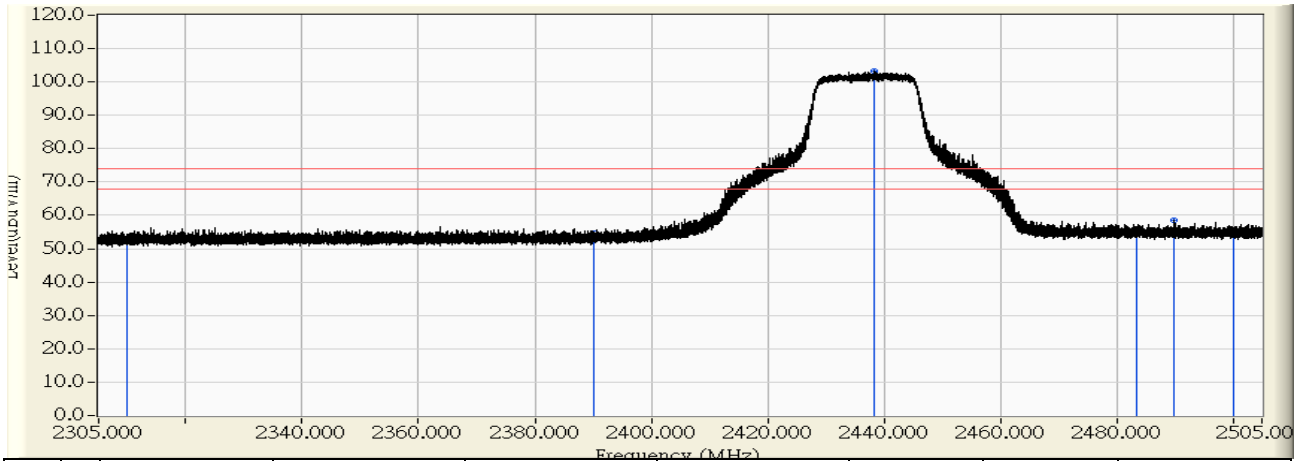

	Frequency (MHz)	Correct Factor (dB)	Reading Level (dBuV)	Measure Level (dBuV/m)	Margin (dB)	Limit (dBuV/m)	Detector Type
1	2310.000	28.130	24.007	52.137	-21.863	74.000	PEAK
2	2390.000	28.933	25.859	54.792	-19.208	74.000	PEAK
3	* 2438.308	29.418	73.857	103.275	29.275	74.000	PEAK
4	2483.500	29.829	25.696	55.525	-18.475	74.000	PEAK
5	2489.944	29.832	28.685	58.517	-15.483	74.000	PEAK
6	2500.000	29.826	25.466	55.291	-18.709	74.000	PEAK

Note:

1. All readings above 1GHz are performed with peak and/or average measurements as necessary.
2. Peak measurements: RBW = 1MHz, VBW = 3 MHz, Sweep: Auto.
3. Average measurements: RBW = 1MHz, VBW = 10 Hz, Sweep: Auto.
4. “ * ”, means this data is the worst emission level.
5. Measurement Level = Reading Level + Correct Factor.
6. The average measurement was not performed when the peak measured data under the limit of average detection.

Site : CB1	Time : 2015/07/29 - 01:06
Limit : FCC_SpartC_15.247_H_03M_AV	Margin : 6
Probe : CB1_FCC_EFS_1-18G_H2 - HORIZONTAL	Power : AC 120 V / 60Hz
EUT : ASUS SRT-AC1900 Wireless Smart Router	Note : Mode 1: Tx- AUX Antenna (AD891M21) 802.11n(20MHz)_2437MHz

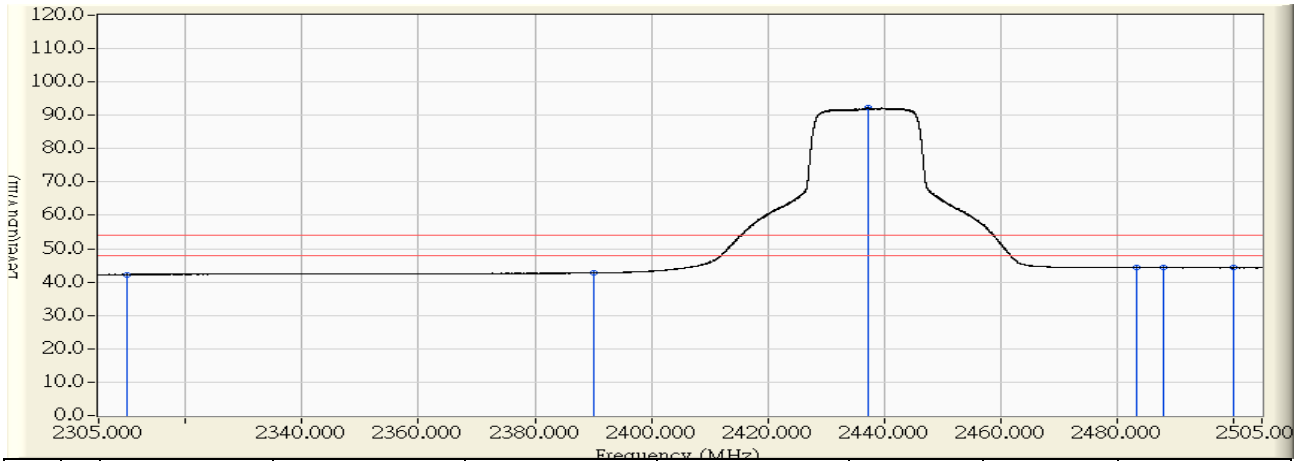

	Frequency (MHz)	Correct Factor (dB)	Reading Level (dBuV)	Measure Level (dBuV/m)	Margin (dB)	Limit (dBuV/m)	Detector Type
1	2310.000	28.130	14.154	42.284	-11.716	54.000	AVERAGE
2	2390.000	28.933	13.807	42.740	-11.260	54.000	AVERAGE
3	* 2437.340	29.408	62.810	92.218	38.218	54.000	AVERAGE
4	2483.500	29.829	14.526	44.355	-9.645	54.000	AVERAGE
5	2487.950	29.831	14.520	44.351	-9.649	54.000	AVERAGE
6	2500.000	29.826	14.419	44.244	-9.756	54.000	AVERAGE

Note:

1. All readings above 1GHz are performed with peak and/or average measurements as necessary.
2. Peak measurements: RBW = 1MHz, VBW = 3 MHz, Sweep: Auto.
3. Average measurements: RBW = 1MHz, VBW = 10 Hz, Sweep: Auto.
4. “ * ”, means this data is the worst emission level.
5. Measurement Level = Reading Level + Correct Factor.
6. The average measurement was not performed when the peak measured data under the limit of average detection.

Site : CB1	Time : 2015/07/29 - 01:00
Limit : FCC_SpartC_15.247_H_03M_PK	Margin : 6
Probe : CB1_FCC_EFS_1-18G_H2 - VERTICAL	Power : AC 120 V / 60Hz
EUT : ASUS SRT-AC1900 Wireless Smart Router	Note : Mode 1: Tx- AUX Antenna (AD891M21) 802.11n(20MHz)_2437MHz

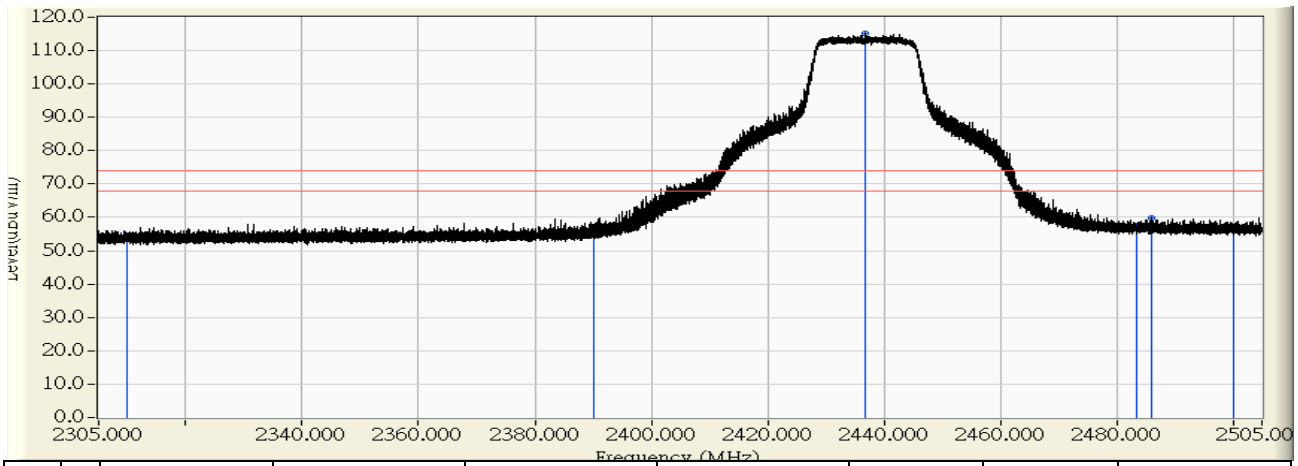

	Frequency (MHz)	Correct Factor (dB)	Reading Level (dBuV)	Measure Level (dBuV/m)	Margin (dB)	Limit (dBuV/m)	Detector Type
1	2310.000	28.784	25.977	54.761	-19.239	74.000	PEAK
2	2390.000	29.747	25.175	54.922	-19.078	74.000	PEAK
3	* 2436.758	30.310	84.932	115.242	41.242	74.000	PEAK
4	2483.500	30.830	26.619	57.449	-16.551	74.000	PEAK
5	2485.944	30.837	28.893	59.729	-14.271	74.000	PEAK
6	2500.000	30.860	26.236	57.095	-16.905	74.000	PEAK

Note:

1. All readings above 1GHz are performed with peak and/or average measurements as necessary.
2. Peak measurements: RBW = 1MHz, VBW = 3 MHz, Sweep: Auto.
3. Average measurements: RBW = 1MHz, VBW = 10 Hz, Sweep: Auto.
4. “ * ”, means this data is the worst emission level.
5. Measurement Level = Reading Level + Correct Factor.
6. The average measurement was not performed when the peak measured data under the limit of average detection.

Site : CB1	Time : 2015/07/29 - 01:00
Limit : FCC_SpartC_15.247_H_03M_AV	Margin : 6
Probe : CB1_FCC_EFS_1-18G_H2 - VERTICAL	Power : AC 120 V / 60Hz
EUT : ASUS SRT-AC1900 Wireless Smart Router	Note : Mode 1: Tx- AUX Antenna (AD891M21) 802.11n(20MHz)_2437MHz

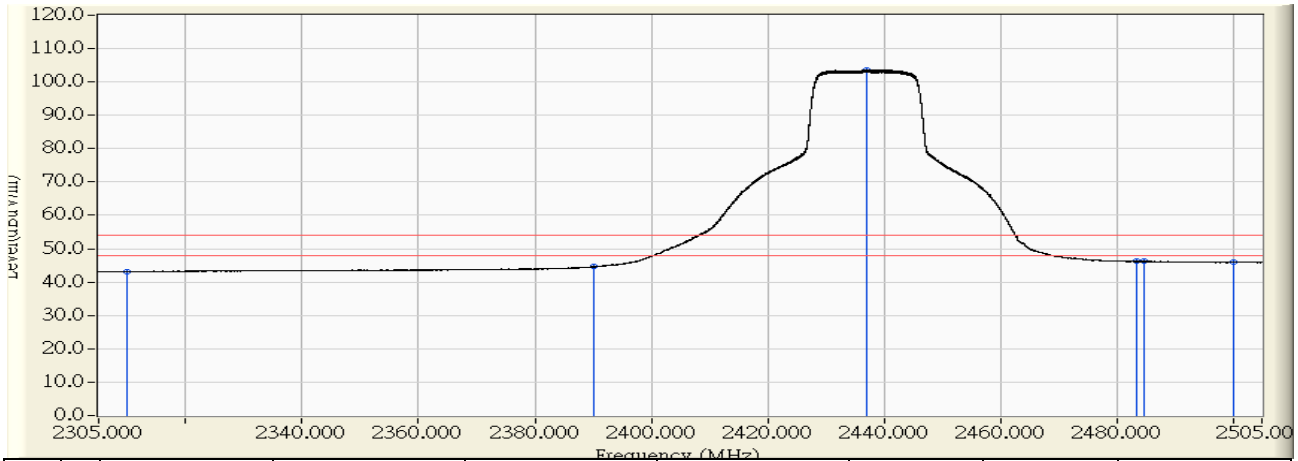

	Frequency (MHz)	Correct Factor (dB)	Reading Level (dBuV)	Measure Level (dBuV/m)	Margin (dB)	Limit (dBuV/m)	Detector Type
1	2310.000	28.784	14.371	43.155	-10.845	54.000	AVERAGE
2	2390.000	29.747	14.831	44.578	-9.422	54.000	AVERAGE
3	* 2437.015	30.313	73.381	103.694	49.694	54.000	AVERAGE
4	2483.500	30.830	15.350	46.180	-7.820	54.000	AVERAGE
5	2484.619	30.833	15.378	46.211	-7.789	54.000	AVERAGE
6	2500.000	30.860	15.119	45.978	-8.022	54.000	AVERAGE

Note:

1. All readings above 1GHz are performed with peak and/or average measurements as necessary.
2. Peak measurements: RBW = 1MHz, VBW = 3 MHz, Sweep: Auto.
3. Average measurements: RBW = 1MHz, VBW = 10 Hz, Sweep: Auto.
4. " * ", means this data is the worst emission level.
5. Measurement Level = Reading Level + Correct Factor.
6. The average measurement was not performed when the peak measured data under the limit of average detection.

Site : CB1	Time : 2015/07/29 - 01:20
Limit : FCC_SpartC_15.247_H_03M_PK	Margin : 6
Probe : CB1_FCC_EFS_1-18G_H2 - HORIZONTAL	Power : AC 120 V / 60Hz
EUT : ASUS SRT-AC1900 Wireless Smart Router	Note : Mode 1: Tx- AUX Antenna (AD891M21) 802.11n(20MHz)_2462MHz

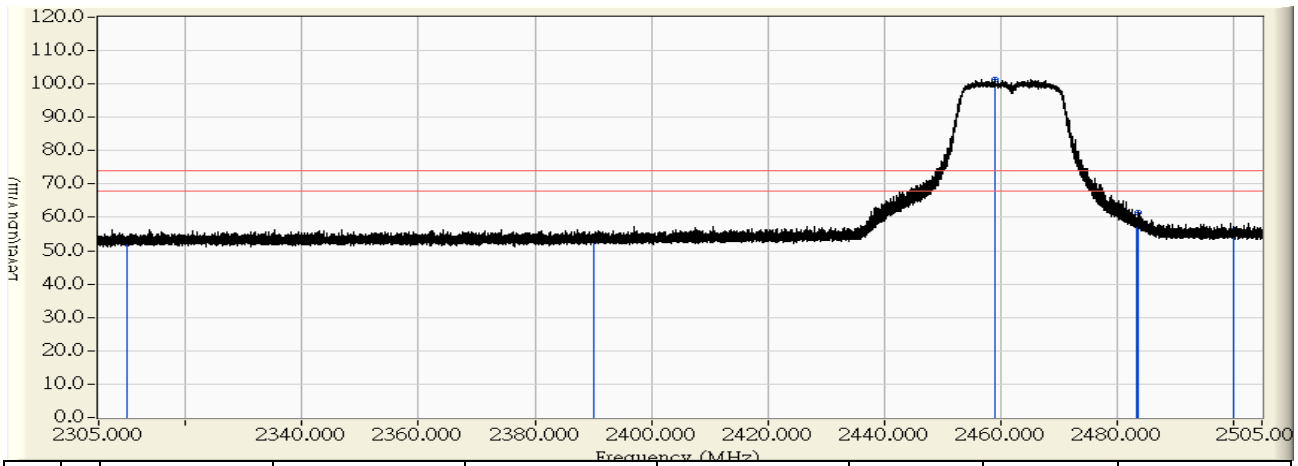

	Frequency (MHz)	Correct Factor (dB)	Reading Level (dBuV)	Measure Level (dBuV/m)	Margin (dB)	Limit (dBuV/m)	Detector Type
1	2310.000	28.130	23.927	52.057	-21.943	74.000	PEAK
2	2390.000	28.933	24.841	53.774	-20.226	74.000	PEAK
3	* 2459.108	29.627	71.856	101.483	27.483	74.000	PEAK
4	2483.500	29.829	28.258	58.087	-15.913	74.000	PEAK
5	2483.632	29.830	31.773	61.602	-12.398	74.000	PEAK
6	2500.000	29.826	26.068	55.893	-18.107	74.000	PEAK

Note:

1. All readings above 1GHz are performed with peak and/or average measurements as necessary.
2. Peak measurements: RBW = 1MHz, VBW = 3 MHz, Sweep: Auto.
3. Average measurements: RBW = 1MHz, VBW = 10 Hz, Sweep: Auto.
4. " * ", means this data is the worst emission level.
5. Measurement Level = Reading Level + Correct Factor.
6. The average measurement was not performed when the peak measured data under the limit of average detection.

Site : CB1	Time : 2015/07/29 - 01:23
Limit : FCC_SpartC_15.247_H_03M_AV	Margin : 6
Probe : CB1_FCC_EFS_1-18G_H2 - HORIZONTAL	Power : AC 120 V / 60Hz
EUT : ASUS SRT-AC1900 Wireless Smart Router	Note : Mode 1: Tx- AUX Antenna (AD891M21) 802.11n(20MHz)_2462MHz

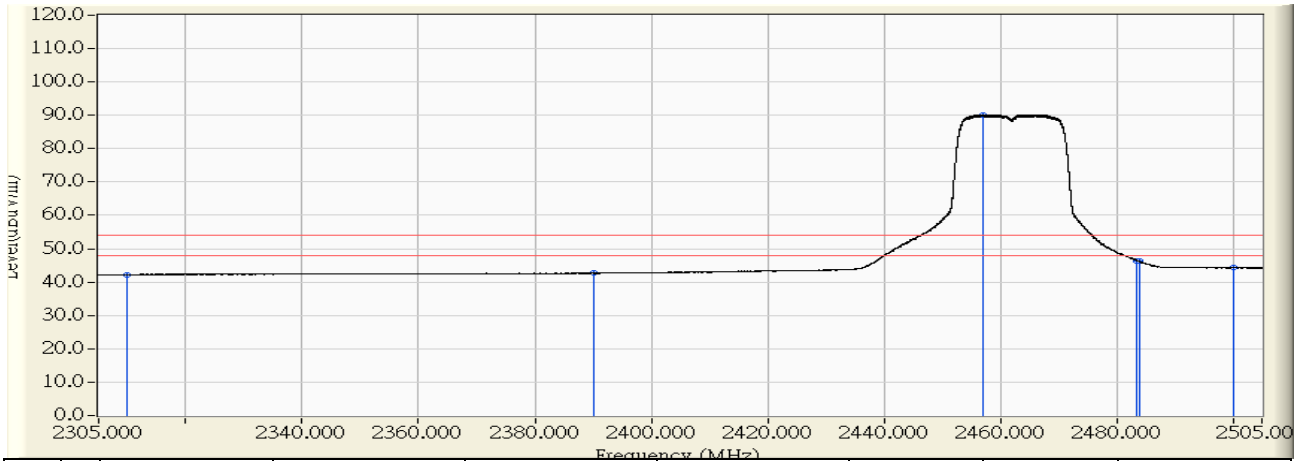

	Frequency (MHz)	Correct Factor (dB)	Reading Level (dBuV)	Measure Level (dBuV/m)	Margin (dB)	Limit (dBuV/m)	Detector Type
1	2310.000	28.130	14.101	42.231	-11.769	54.000	AVERAGE
2	2390.000	28.933	13.736	42.669	-11.331	54.000	AVERAGE
3	* 2457.008	29.606	60.602	90.208	36.208	54.000	AVERAGE
4	2483.500	29.829	16.500	46.329	-7.671	54.000	AVERAGE
5	2483.851	29.830	16.431	46.260	-7.740	54.000	AVERAGE
6	2500.000	29.826	14.497	44.322	-9.678	54.000	AVERAGE

Note:

1. All readings above 1GHz are performed with peak and/or average measurements as necessary.
2. Peak measurements: RBW = 1MHz, VBW = 3 MHz, Sweep: Auto.
3. Average measurements: RBW = 1MHz, VBW = 10 Hz, Sweep: Auto.
4. “ * ”, means this data is the worst emission level.
5. Measurement Level = Reading Level + Correct Factor.
6. The average measurement was not performed when the peak measured data under the limit of average detection.

Site : CB1	Time : 2015/07/29 - 01:12
Limit : FCC_SpartC_15.247_H_03M_PK	Margin : 6
Probe : CB1_FCC_EFS_1-18G_H2 - VERTICAL	Power : AC 120 V / 60Hz
EUT : ASUS SRT-AC1900 Wireless Smart Router	Note : Mode 1: Tx- AUX Antenna (AD891M21) 802.11n(20MHz)_2462MHz

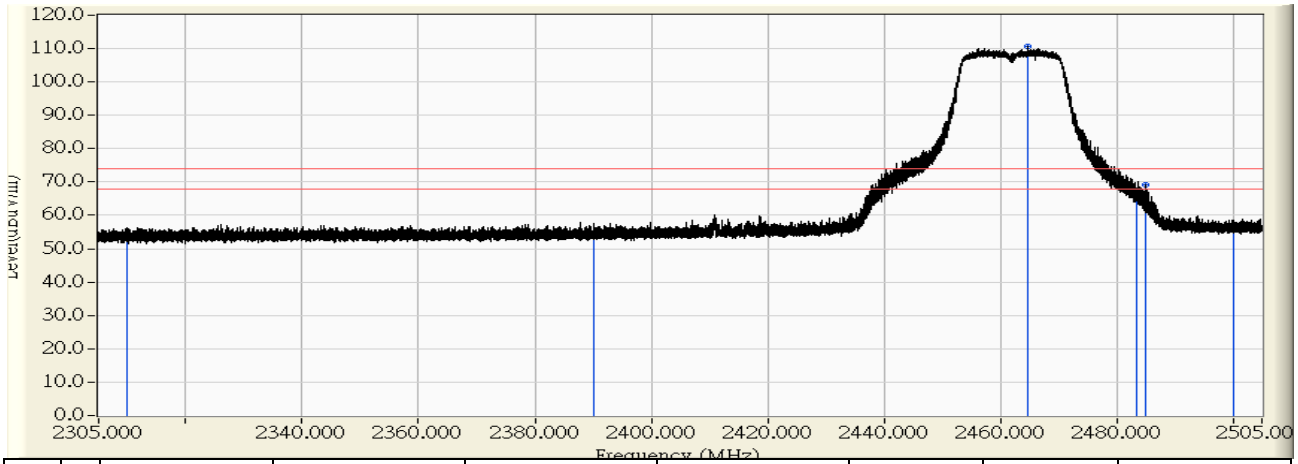

	Frequency (MHz)	Correct Factor (dB)	Reading Level (dBuV)	Measure Level (dBuV/m)	Margin (dB)	Limit (dBuV/m)	Detector Type
1	2310.000	28.784	25.918	54.702	-19.298	74.000	PEAK
2	2390.000	29.747	24.457	54.204	-19.796	74.000	PEAK
3	* 2464.839	30.649	80.064	110.712	36.712	74.000	PEAK
4	2483.500	30.830	36.469	67.299	-6.701	74.000	PEAK
5	2484.894	30.833	38.468	69.302	-4.698	74.000	PEAK
6	2500.000	30.860	26.234	57.093	-16.907	74.000	PEAK

Note:

1. All readings above 1GHz are performed with peak and/or average measurements as necessary.
2. Peak measurements: RBW = 1MHz, VBW = 3 MHz, Sweep: Auto.
3. Average measurements: RBW = 1MHz, VBW = 10 Hz, Sweep: Auto.
4. “ * ”, means this data is the worst emission level.
5. Measurement Level = Reading Level + Correct Factor.
6. The average measurement was not performed when the peak measured data under the limit of average detection.

Site : CB1	Time : 2015/07/29 - 01:11
Limit : FCC_SpartC_15.247_H_03M_AV	Margin : 6
Probe : CB1_FCC_EFS_1-18G_H2 - VERTICAL	Power : AC 120 V / 60Hz
EUT : ASUS SRT-AC1900 Wireless Smart Router	Note : Mode 1: Tx- AUX Antenna (AD891M21) 802.11n(20MHz)_2462MHz

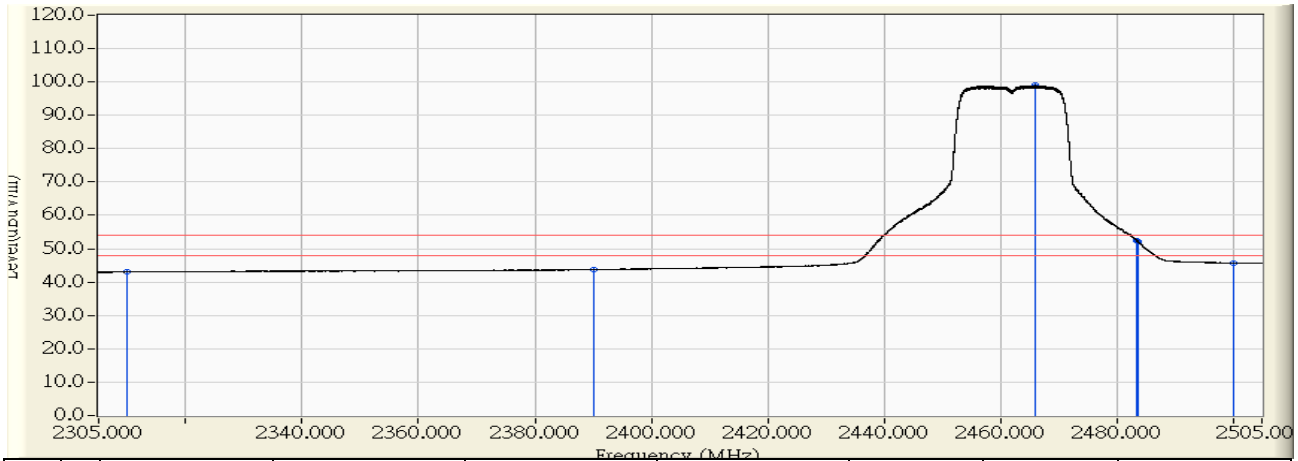

	Frequency (MHz)	Correct Factor (dB)	Reading Level (dBuV)	Measure Level (dBuV/m)	Margin (dB)	Limit (dBuV/m)	Detector Type
1	2310.000	28.784	14.233	43.017	-10.983	54.000	AVERAGE
2	2390.000	29.747	13.999	43.746	-10.254	54.000	AVERAGE
3	* 2466.070	30.663	68.281	98.944	44.944	54.000	AVERAGE
4	2483.500	30.830	21.744	52.574	-1.426	54.000	AVERAGE
5	2483.788	30.831	21.227	52.058	-1.942	54.000	AVERAGE
6	2500.000	30.860	14.904	45.763	-8.237	54.000	AVERAGE

Note:

1. All readings above 1GHz are performed with peak and/or average measurements as necessary.
2. Peak measurements: RBW = 1MHz, VBW = 3 MHz, Sweep: Auto.
3. Average measurements: RBW = 1MHz, VBW = 10 Hz, Sweep: Auto.
4. “ * ”, means this data is the worst emission level.
5. Measurement Level = Reading Level + Correct Factor.
6. The average measurement was not performed when the peak measured data under the limit of average detection.

Site : CB1	Time : 2015/07/29 - 01:36
Limit : FCC_SpartC_15.247_H_03M_PK	Margin : 6
Probe : CB1_FCC_EFS_1-18G_H2 - HORIZONTAL	Power : AC 120 V / 60Hz
EUT : ASUS SRT-AC1900 Wireless Smart Router	Note : Mode 1: Tx- AUX Antenna (AD891M21) 802.11n(40MHz)_2422MHz

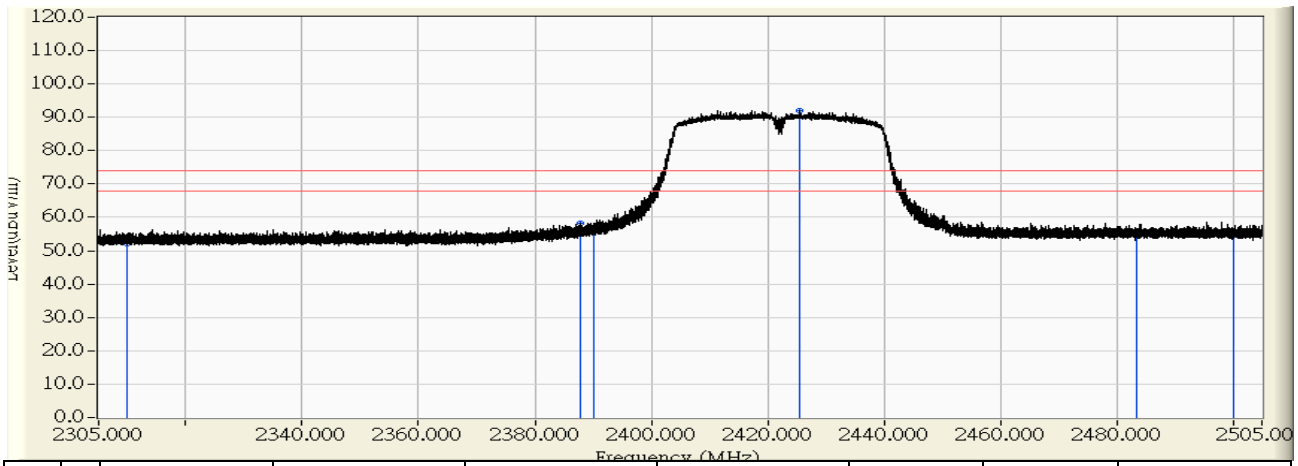

	Frequency (MHz)	Correct Factor (dB)	Reading Level (dBuV)	Measure Level (dBuV/m)	Margin (dB)	Limit (dBuV/m)	Detector Type
1	2310.000	28.130	24.024	52.154	-21.846	74.000	PEAK
2	2387.854	28.911	29.423	58.335	-15.665	74.000	PEAK
3	2390.000	28.933	26.585	55.518	-18.482	74.000	PEAK
4	* 2425.602	29.290	62.794	92.085	18.085	74.000	PEAK
5	2483.500	29.829	25.051	54.880	-19.120	74.000	PEAK
6	2500.000	29.826	24.974	54.799	-19.201	74.000	PEAK

Note:

1. All readings above 1GHz are performed with peak and/or average measurements as necessary.
2. Peak measurements: RBW = 1MHz, VBW = 3 MHz, Sweep: Auto.
3. Average measurements: RBW = 1MHz, VBW = 10 Hz, Sweep: Auto.
4. " * ", means this data is the worst emission level.
5. Measurement Level = Reading Level + Correct Factor.
6. The average measurement was not performed when the peak measured data under the limit of average detection.

Site : CB1	Time : 2015/07/29 - 01:38
Limit : FCC_SpartC_15.247_H_03M_AV	Margin : 6
Probe : CB1_FCC_EFS_1-18G_H2 - HORIZONTAL	Power : AC 120 V / 60Hz
EUT : ASUS SRT-AC1900 Wireless Smart Router	Note : Mode 1: Tx- AUX Antenna (AD891M21) 802.11n(40MHz)_2422MHz

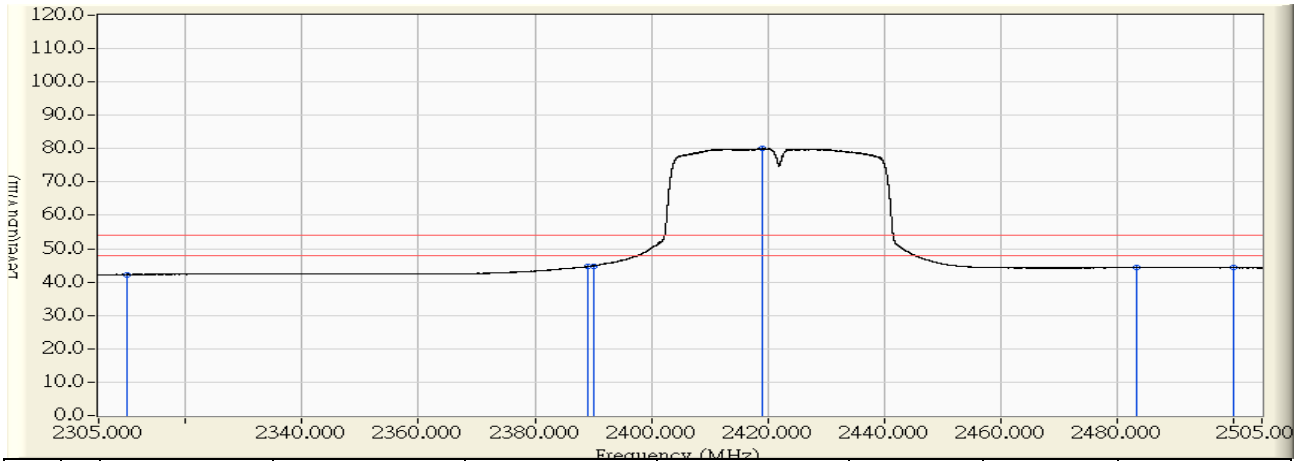

	Frequency (MHz)	Correct Factor (dB)	Reading Level (dBuV)	Measure Level (dBuV/m)	Margin (dB)	Limit (dBuV/m)	Detector Type
1	2310.000	28.130	14.158	42.288	-11.712	54.000	AVERAGE
2	2389.229	28.925	15.826	44.751	-9.249	54.000	AVERAGE
3	2390.000	28.933	15.939	44.872	-9.128	54.000	AVERAGE
4	* 2419.228	29.226	50.793	80.020	26.020	54.000	AVERAGE
5	2483.500	29.829	14.483	44.312	-9.688	54.000	AVERAGE
6	2500.000	29.826	14.500	44.325	-9.675	54.000	AVERAGE

Note:

1. All readings above 1GHz are performed with peak and/or average measurements as necessary.
2. Peak measurements: RBW = 1MHz, VBW = 3 MHz, Sweep: Auto.
3. Average measurements: RBW = 1MHz, VBW = 10 Hz, Sweep: Auto.
4. “ * ”, means this data is the worst emission level.
5. Measurement Level = Reading Level + Correct Factor.
6. The average measurement was not performed when the peak measured data under the limit of average detection.

Site : CB1	Time : 2015/07/29 - 01:32
Limit : FCC_SpartC_15.247_H_03M_PK	Margin : 6
Probe : CB1_FCC_EFS_1-18G_H2 - VERTICAL	Power : AC 120 V / 60Hz
EUT : ASUS SRT-AC1900 Wireless Smart Router	Note : Mode 1: Tx- AUX Antenna (AD891M21) 802.11n(40MHz)_2422MHz

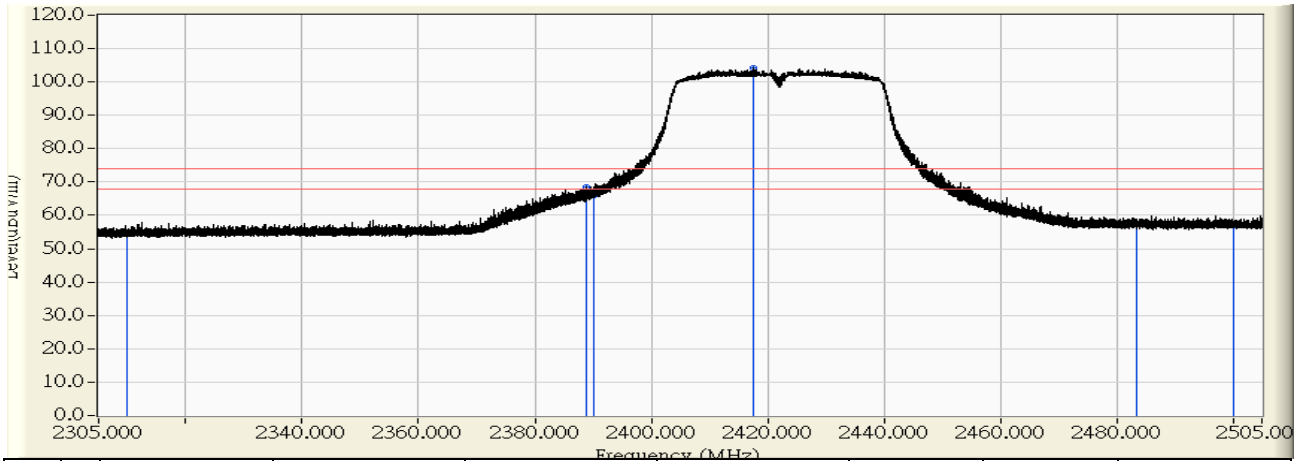

	Frequency (MHz)	Correct Factor (dB)	Reading Level (dBuV)	Measure Level (dBuV/m)	Margin (dB)	Limit (dBuV/m)	Detector Type
1	2310.000	28.784	25.649	54.433	-19.567	74.000	PEAK
2	2388.741	29.732	38.643	68.375	-5.625	74.000	PEAK
3	2390.000	29.747	36.066	65.813	-8.187	74.000	PEAK
4	* 2417.628	30.080	74.104	104.184	30.184	74.000	PEAK
5	2483.500	30.830	26.571	57.401	-16.599	74.000	PEAK
6	2500.000	30.860	26.001	56.860	-17.140	74.000	PEAK

Note:

1. All readings above 1GHz are performed with peak and/or average measurements as necessary.
2. Peak measurements: RBW = 1MHz, VBW = 3 MHz, Sweep: Auto.
3. Average measurements: RBW = 1MHz, VBW = 10 Hz, Sweep: Auto.
4. “ * ”, means this data is the worst emission level.
5. Measurement Level = Reading Level + Correct Factor.
6. The average measurement was not performed when the peak measured data under the limit of average detection.

Site : CB1	Time : 2015/07/29 - 01:30
Limit : FCC_SpartC_15.247_H_03M_AV	Margin : 6
Probe : CB1_FCC_EFS_1-18G_H2 - VERTICAL	Power : AC 120 V / 60Hz
EUT : ASUS SRT-AC1900 Wireless Smart Router	Note : Mode 1: Tx- AUX Antenna (AD891M21) 802.11n(40MHz)_2422MHz

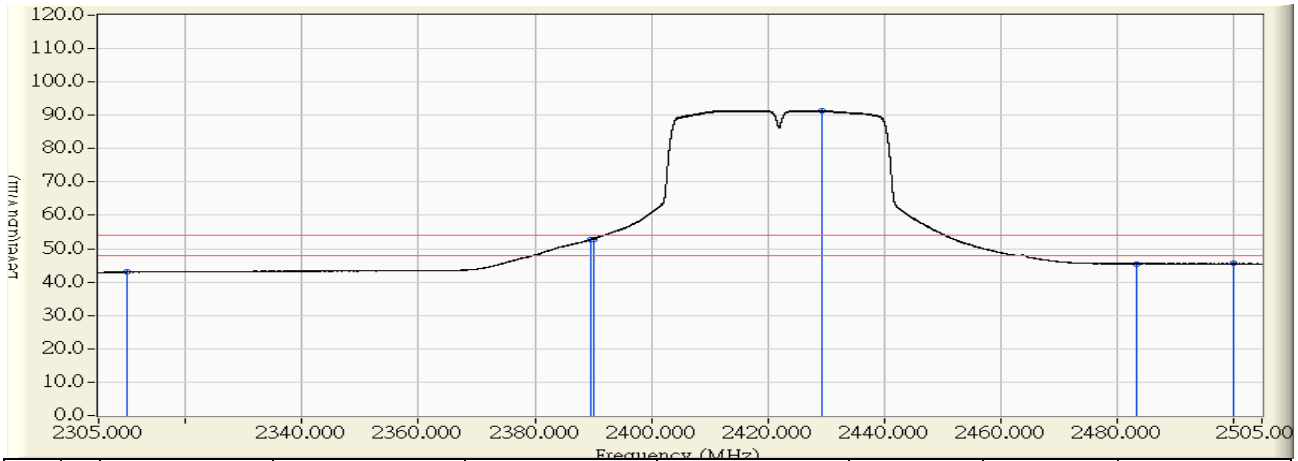

	Frequency (MHz)	Correct Factor (dB)	Reading Level (dBuV)	Measure Level (dBuV/m)	Margin (dB)	Limit (dBuV/m)	Detector Type
1	2310.000	28.784	14.238	43.022	-10.978	54.000	AVERAGE
2	2389.616	29.742	23.031	52.773	-1.227	54.000	AVERAGE
3	2390.000	29.747	23.148	52.895	-1.105	54.000	AVERAGE
4	* 2429.240	30.220	61.187	91.407	37.407	54.000	AVERAGE
5	2483.500	30.830	14.673	45.503	-8.497	54.000	AVERAGE
6	2500.000	30.860	14.674	45.533	-8.467	54.000	AVERAGE

Note:

1. All readings above 1GHz are performed with peak and/or average measurements as necessary.
2. Peak measurements: RBW = 1MHz, VBW = 3 MHz, Sweep: Auto.
3. Average measurements: RBW = 1MHz, VBW = 10 Hz, Sweep: Auto.
4. “ * ”, means this data is the worst emission level.
5. Measurement Level = Reading Level + Correct Factor.
6. The average measurement was not performed when the peak measured data under the limit of average detection.

Site : CB1	Time : 2015/07/29 - 01:59
Limit : FCC_SpartC_15.247_H_03M_PK	Margin : 6
Probe : CB1_FCC_EFS_1-18G_H2 - HORIZONTAL	Power : AC 120 V / 60Hz
EUT : ASUS SRT-AC1900 Wireless Smart Router	Note : Mode 1: Tx- AUX Antenna (AD891M21) 802.11n(40MHz)_2437MHz

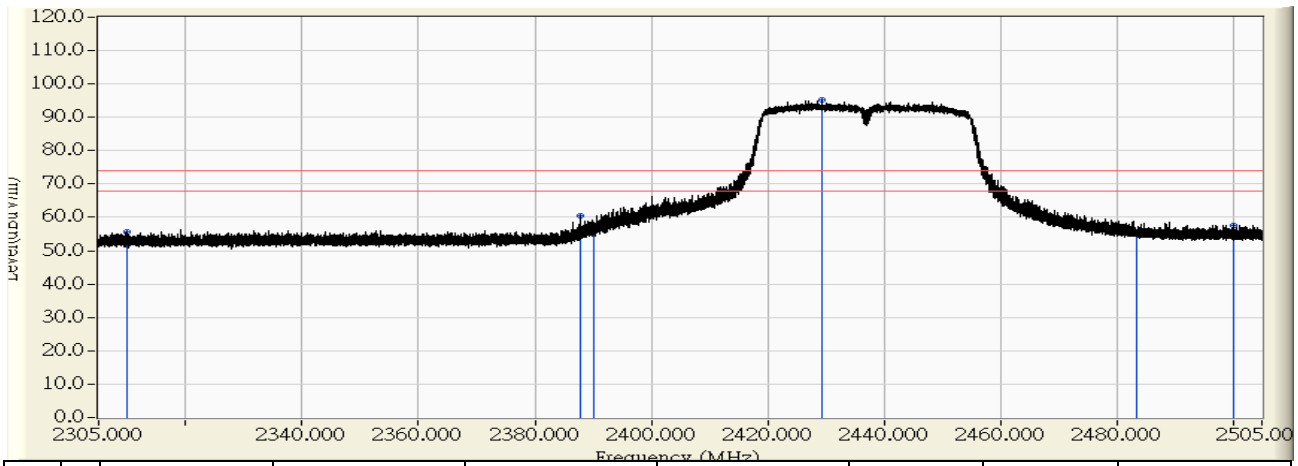

	Frequency (MHz)	Correct Factor (dB)	Reading Level (dBuV)	Measure Level (dBuV/m)	Margin (dB)	Limit (dBuV/m)	Detector Type
1	2310.000	28.130	27.463	55.593	-18.407	74.000	PEAK
2	2387.829	28.911	31.659	60.570	-13.430	74.000	PEAK
3	2390.000	28.933	27.340	56.273	-17.727	74.000	PEAK
4	* 2429.459	29.330	65.856	95.185	21.185	74.000	PEAK
5	2483.500	29.829	25.940	55.769	-18.231	74.000	PEAK
6	2500.000	29.826	27.921	57.746	-16.254	74.000	PEAK

Note:

1. All readings above 1GHz are performed with peak and/or average measurements as necessary.
2. Peak measurements: RBW = 1MHz, VBW = 3 MHz, Sweep: Auto.
3. Average measurements: RBW = 1MHz, VBW = 10 Hz, Sweep: Auto.
4. “ * ”, means this data is the worst emission level.
5. Measurement Level = Reading Level + Correct Factor.
6. The average measurement was not performed when the peak measured data under the limit of average detection.

Site : CB1	Time : 2015/07/29 - 02:00
Limit : FCC_SpartC_15.247_H_03M_AV	Margin : 6
Probe : CB1_FCC_EFS_1-18G_H2 - HORIZONTAL	Power : AC 120 V / 60Hz
EUT : ASUS SRT-AC1900 Wireless Smart Router	Note : Mode 1: Tx- AUX Antenna (AD891M21) 802.11n(40MHz)_2437MHz

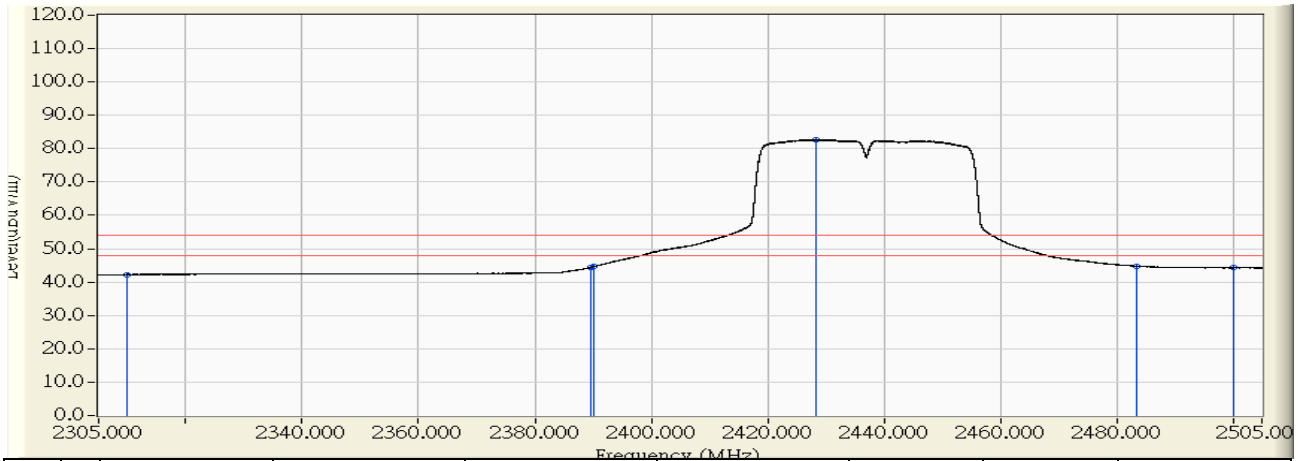

	Frequency (MHz)	Correct Factor (dB)	Reading Level (dBuV)	Measure Level (dBuV/m)	Margin (dB)	Limit (dBuV/m)	Detector Type
1	2310.000	28.130	14.173	42.303	-11.697	54.000	AVERAGE
2	2389.491	28.928	15.442	44.370	-9.630	54.000	AVERAGE
3	2390.000	28.933	15.671	44.604	-9.396	54.000	AVERAGE
4	* 2428.396	29.318	53.486	82.805	28.805	54.000	AVERAGE
5	2483.500	29.829	14.936	44.765	-9.235	54.000	AVERAGE
6	2500.000	29.826	14.429	44.254	-9.746	54.000	AVERAGE

Note:

1. All readings above 1GHz are performed with peak and/or average measurements as necessary.
2. Peak measurements: RBW = 1MHz, VBW = 3 MHz, Sweep: Auto.
3. Average measurements: RBW = 1MHz, VBW = 10 Hz, Sweep: Auto.
4. “ * ”, means this data is the worst emission level.
5. Measurement Level = Reading Level + Correct Factor.
6. The average measurement was not performed when the peak measured data under the limit of average detection.

Site : CB1	Time : 2015/07/29 - 01:51
Limit : FCC_SpartC_15.247_H_03M_PK	Margin : 6
Probe : CB1_FCC_EFS_1-18G_H2 - VERTICAL	Power : AC 120 V / 60Hz
EUT : ASUS SRT-AC1900 Wireless Smart Router	Note : Mode 1: Tx- AUX Antenna (AD891M21) 802.11n(40MHz)_2437MHz

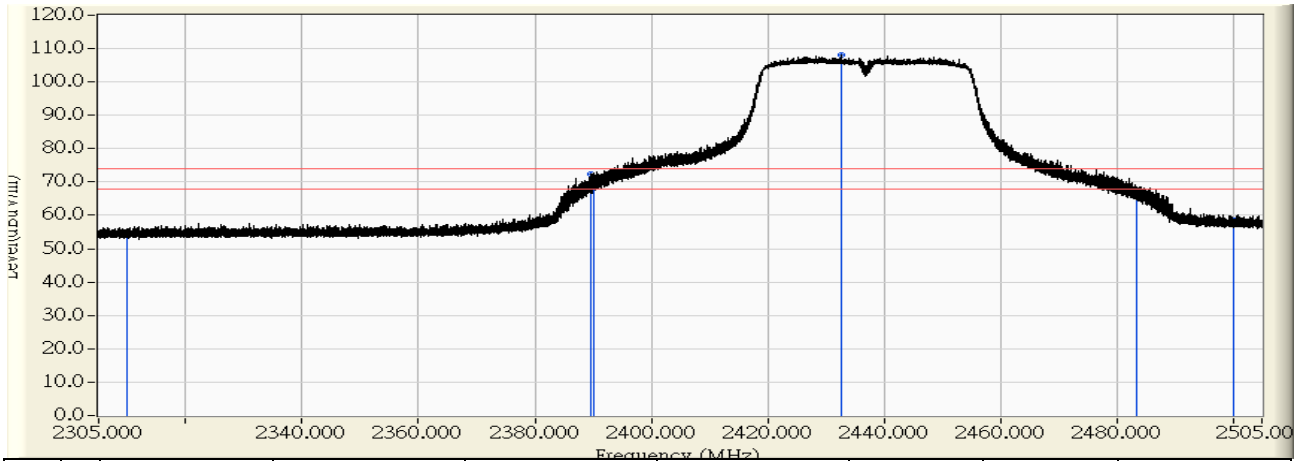

	Frequency (MHz)	Correct Factor (dB)	Reading Level (dBuV)	Measure Level (dBuV/m)	Margin (dB)	Limit (dBuV/m)	Detector Type
1	2310.000	28.784	25.281	54.065	-19.935	74.000	PEAK
2	2389.654	29.743	42.771	72.514	-1.486	74.000	PEAK
3	2390.000	29.747	38.762	68.509	-5.491	74.000	PEAK
4	* 2432.633	30.261	77.730	107.990	33.990	74.000	PEAK
5	2483.500	30.830	36.467	67.297	-6.703	74.000	PEAK
6	2500.000	30.860	27.814	58.673	-15.327	74.000	PEAK

Note:

1. All readings above 1GHz are performed with peak and/or average measurements as necessary.
2. Peak measurements: RBW = 1MHz, VBW = 3 MHz, Sweep: Auto.
3. Average measurements: RBW = 1MHz, VBW = 10 Hz, Sweep: Auto.
4. “ * ”, means this data is the worst emission level.
5. Measurement Level = Reading Level + Correct Factor.
6. The average measurement was not performed when the peak measured data under the limit of average detection.

Site : CB1	Time : 2015/07/29 - 01:48
Limit : FCC_SpartC_15.247_H_03M_AV	Margin : 6
Probe : CB1_FCC_EFS_1-18G_H2 - VERTICAL	Power : AC 120 V / 60Hz
EUT : ASUS SRT-AC1900 Wireless Smart Router	Note : Mode 1: Tx- AUX Antenna (AD891M21) 802.11n(40MHz)_2437MHz

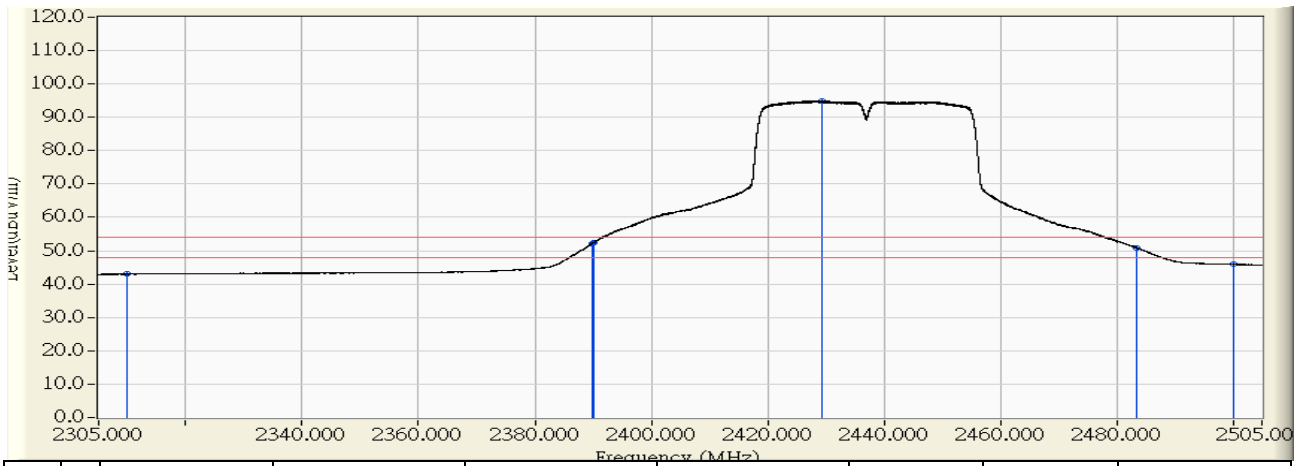

	Frequency (MHz)	Correct Factor (dB)	Reading Level (dBuV)	Measure Level (dBuV/m)	Margin (dB)	Limit (dBuV/m)	Detector Type
1	2310.000	28.784	14.190	42.974	-11.026	54.000	AVERAGE
2	2389.835	29.745	22.514	52.259	-1.741	54.000	AVERAGE
3	2390.000	29.747	22.739	52.486	-1.514	54.000	AVERAGE
4	* 2429.259	30.220	64.715	94.935	40.935	54.000	AVERAGE
5	2483.500	30.830	19.946	50.776	-3.224	54.000	AVERAGE
6	2500.000	30.860	15.046	45.905	-8.095	54.000	AVERAGE

Note:

1. All readings above 1GHz are performed with peak and/or average measurements as necessary.
2. Peak measurements: RBW = 1MHz, VBW = 3 MHz, Sweep: Auto.
3. Average measurements: RBW = 1MHz, VBW = 10 Hz, Sweep: Auto.
4. “ * ”, means this data is the worst emission level.
5. Measurement Level = Reading Level + Correct Factor.
6. The average measurement was not performed when the peak measured data under the limit of average detection.

Site : CB1	Time : 2015/07/29 - 02:14
Limit : FCC_SpartC_15.247_H_03M_PK	Margin : 6
Probe : CB1_FCC_EFS_1-18G_H2 - HORIZONTAL	Power : AC 120 V / 60Hz
EUT : ASUS SRT-AC1900 Wireless Smart Router	Note : Mode 1: Tx- AUX Antenna (AD891M21) 802.11n(40MHz)_2452MHz

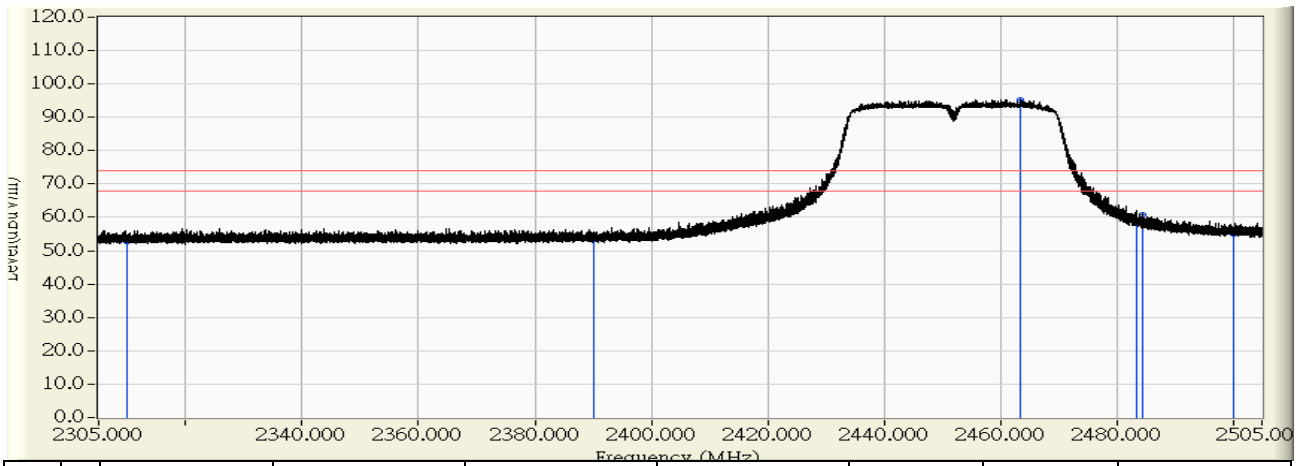

	Frequency (MHz)	Correct Factor (dB)	Reading Level (dBuV)	Measure Level (dBuV/m)	Margin (dB)	Limit (dBuV/m)	Detector Type
1	2310.000	28.130	24.774	52.904	-21.096	74.000	PEAK
2	2390.000	28.933	24.599	53.532	-20.468	74.000	PEAK
3	* 2463.389	29.670	65.705	95.375	21.375	74.000	PEAK
4	2483.500	29.829	29.084	58.913	-15.087	74.000	PEAK
5	2484.426	29.830	31.006	60.835	-13.165	74.000	PEAK
6	2500.000	29.826	25.294	55.119	-18.881	74.000	PEAK

Note:

1. All readings above 1GHz are performed with peak and/or average measurements as necessary.
2. Peak measurements: RBW = 1MHz, VBW = 3 MHz, Sweep: Auto.
3. Average measurements: RBW = 1MHz, VBW = 10 Hz, Sweep: Auto.
4. “ * ”, means this data is the worst emission level.
5. Measurement Level = Reading Level + Correct Factor.
6. The average measurement was not performed when the peak measured data under the limit of average detection.

Site : CB1	Time : 2015/07/29 - 02:16
Limit : FCC_SpartC_15.247_H_03M_AV	Margin : 6
Probe : CB1_FCC_EFS_1-18G_H2 - HORIZONTAL	Power : AC 120 V / 60Hz
EUT : ASUS SRT-AC1900 Wireless Smart Router	Note : Mode 1: Tx- AUX Antenna (AD891M21) 802.11n(40MHz)_2452MHz

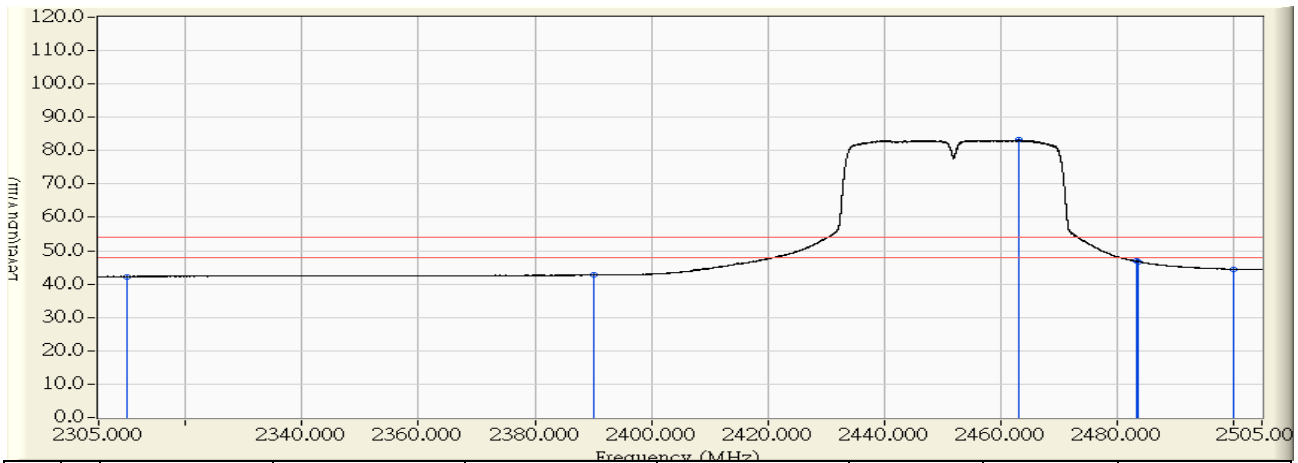

	Frequency (MHz)	Correct Factor (dB)	Reading Level (dBuV)	Measure Level (dBuV/m)	Margin (dB)	Limit (dBuV/m)	Detector Type
1	2310.000	28.130	14.139	42.269	-11.731	54.000	AVERAGE
2	2390.000	28.933	13.745	42.678	-11.322	54.000	AVERAGE
3	* 2463.157	29.668	53.503	83.171	29.171	54.000	AVERAGE
4	2483.500	29.829	16.991	46.820	-7.180	54.000	AVERAGE
5	2483.594	29.829	16.964	46.793	-7.207	54.000	AVERAGE
6	2500.000	29.826	14.658	44.483	-9.517	54.000	AVERAGE

Note:

1. All readings above 1GHz are performed with peak and/or average measurements as necessary.
2. Peak measurements: RBW = 1MHz, VBW = 3 MHz, Sweep: Auto.
3. Average measurements: RBW = 1MHz, VBW = 10 Hz, Sweep: Auto.
4. “ * ”, means this data is the worst emission level.
5. Measurement Level = Reading Level + Correct Factor.
6. The average measurement was not performed when the peak measured data under the limit of average detection.

Site : CB1	Time : 2015/07/29 - 02:08
Limit : FCC_SpartC_15.247_H_03M_PK	Margin : 6
Probe : CB1_FCC_EFS_1-18G_H2 - VERTICAL	Power : AC 120 V / 60Hz
EUT : ASUS SRT-AC1900 Wireless Smart Router	Note : Mode 1: Tx- AUX Antenna (AD891M21) 802.11n(40MHz)_2452MHz

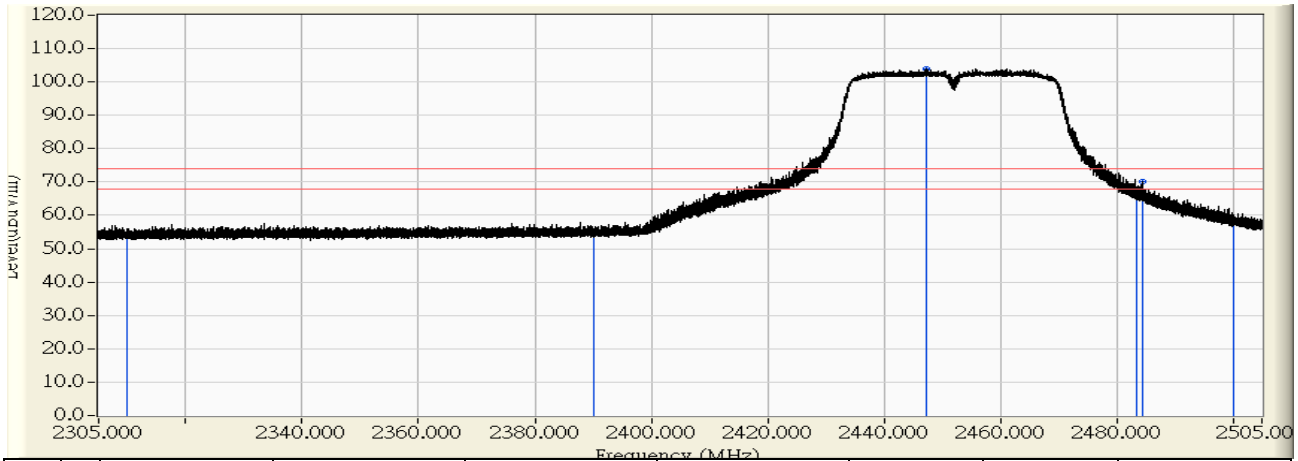

	Frequency (MHz)	Correct Factor (dB)	Reading Level (dBuV)	Measure Level (dBuV/m)	Margin (dB)	Limit (dBuV/m)	Detector Type
1	2310.000	28.784	25.535	54.319	-19.681	74.000	PEAK
2	2390.000	29.747	25.467	55.214	-18.786	74.000	PEAK
3	* 2447.358	30.438	73.409	103.847	29.847	74.000	PEAK
4	2483.500	30.830	36.248	67.078	-6.922	74.000	PEAK
5	2484.419	30.832	39.227	70.059	-3.941	74.000	PEAK
6	2500.000	30.860	27.928	58.787	-15.213	74.000	PEAK

Note:

1. All readings above 1GHz are performed with peak and/or average measurements as necessary.
2. Peak measurements: RBW = 1MHz, VBW = 3 MHz, Sweep: Auto.
3. Average measurements: RBW = 1MHz, VBW = 10 Hz, Sweep: Auto.
4. “ * ”, means this data is the worst emission level.
5. Measurement Level = Reading Level + Correct Factor.
6. The average measurement was not performed when the peak measured data under the limit of average detection.

Site : CB1	Time : 2015/07/29 - 02:07
Limit : FCC_SpartC_15.247_H_03M_AV	Margin : 6
Probe : CB1_FCC_EFS_1-18G_H2 - VERTICAL	Power : AC 120 V / 60Hz
EUT : ASUS SRT-AC1900 Wireless Smart Router	Note : Mode 1: Tx- AUX Antenna (AD891M21) 802.11n(40MHz)_2452MHz

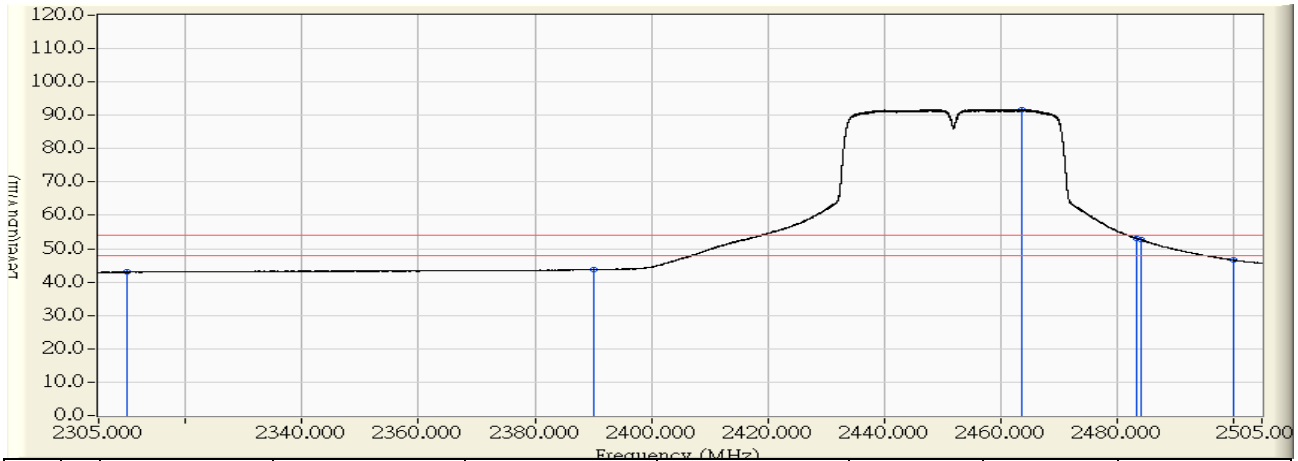

	Frequency (MHz)	Correct Factor (dB)	Reading Level (dBuV)	Measure Level (dBuV/m)	Margin (dB)	Limit (dBuV/m)	Detector Type
1	2310.000	28.784	14.172	42.956	-11.044	54.000	AVERAGE
2	2390.000	29.747	13.965	43.712	-10.288	54.000	AVERAGE
3	* 2463.751	30.635	61.130	91.765	37.765	54.000	AVERAGE
4	2483.500	30.830	22.230	53.060	-0.940	54.000	AVERAGE
5	2484.113	30.832	21.938	52.770	-1.230	54.000	AVERAGE
6	2500.000	30.860	15.754	46.613	-7.387	54.000	AVERAGE

Note:

1. All readings above 1GHz are performed with peak and/or average measurements as necessary.
2. Peak measurements: RBW = 1MHz, VBW = 3 MHz, Sweep: Auto.
3. Average measurements: RBW = 1MHz, VBW = 10 Hz, Sweep: Auto.
4. “ * ”, means this data is the worst emission level.
5. Measurement Level = Reading Level + Correct Factor.
6. The average measurement was not performed when the peak measured data under the limit of average detection.

7. DTS Occupied Bandwidth

7.1. Test Equipment

The following test equipments are used during the test:

DTS Occupied Bandwidth / SR7

Instrument	Manufacturer	Model No.	Serial No	Next Cal. Date
Spectrum Analyzer	Agilent	N9010A-EXA	US47140172	2016/07/13

Note: 1. All equipments that need to calibrate are with calibration period of 1 year.

7.2. Test Setup

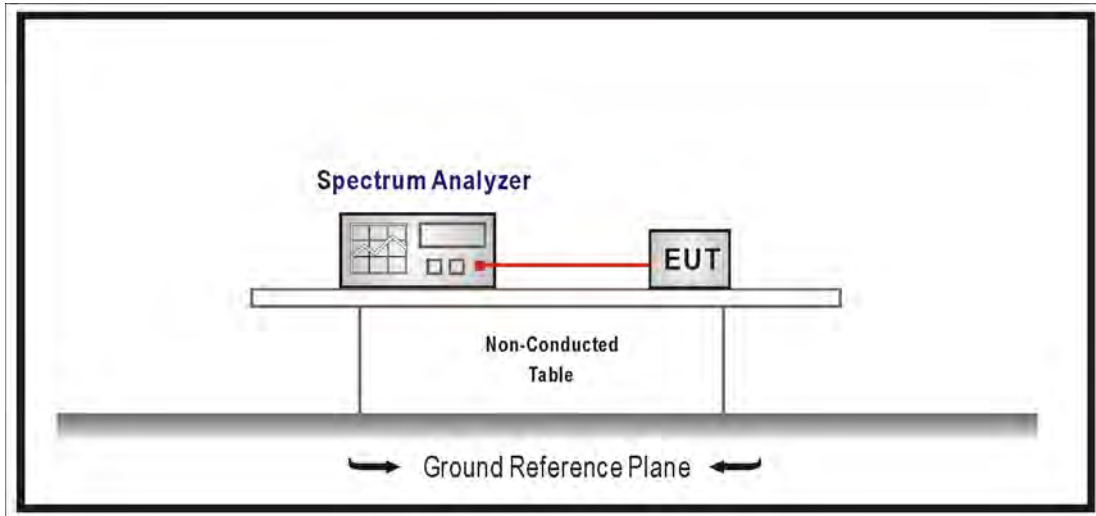

7.3. Test Procedures

The EUT was setup according to ANSI C63.10:2013; tested procedure section 8.1 of KDB558074 v03r02 for compliance to FCC 47CFR 15.247 requirements. Set RBW = 100KHz, Set the VBW $\geq 3 \times$ RBW, Sweep Time=Auto, Set Peak Detector.

7.4. Limits

The 6 dB bandwidth must be greater than 500 kHz.

7.5. Test Specification

According to FCC Part 15 Subpart C Paragraph 15.247: 2014

7.6. Uncertainty

The measurement uncertainty is defined as ± 150 Hz

7.7. Test Result

Product	ASUS SRT-AC1900 Wireless Smart Router		
Test Item	DTS Occupied Bandwidth		
Test Mode	Mode 1: Tx- AUX Antenna (AD891M21)		
Date of Test	2015/08/10	Test Site	SR7

802.11 b (ANT 0)				
Channel No.	Frequency (MHz)	Measurement Level (MHz)	Required Limit (MHz)	Result
1	2412	10.08	≥ 0.5	Pass
6	2437	10.07	≥ 0.5	Pass
11	2462	10.07	≥ 0.5	Pass

Channel 1 (2412MHz)

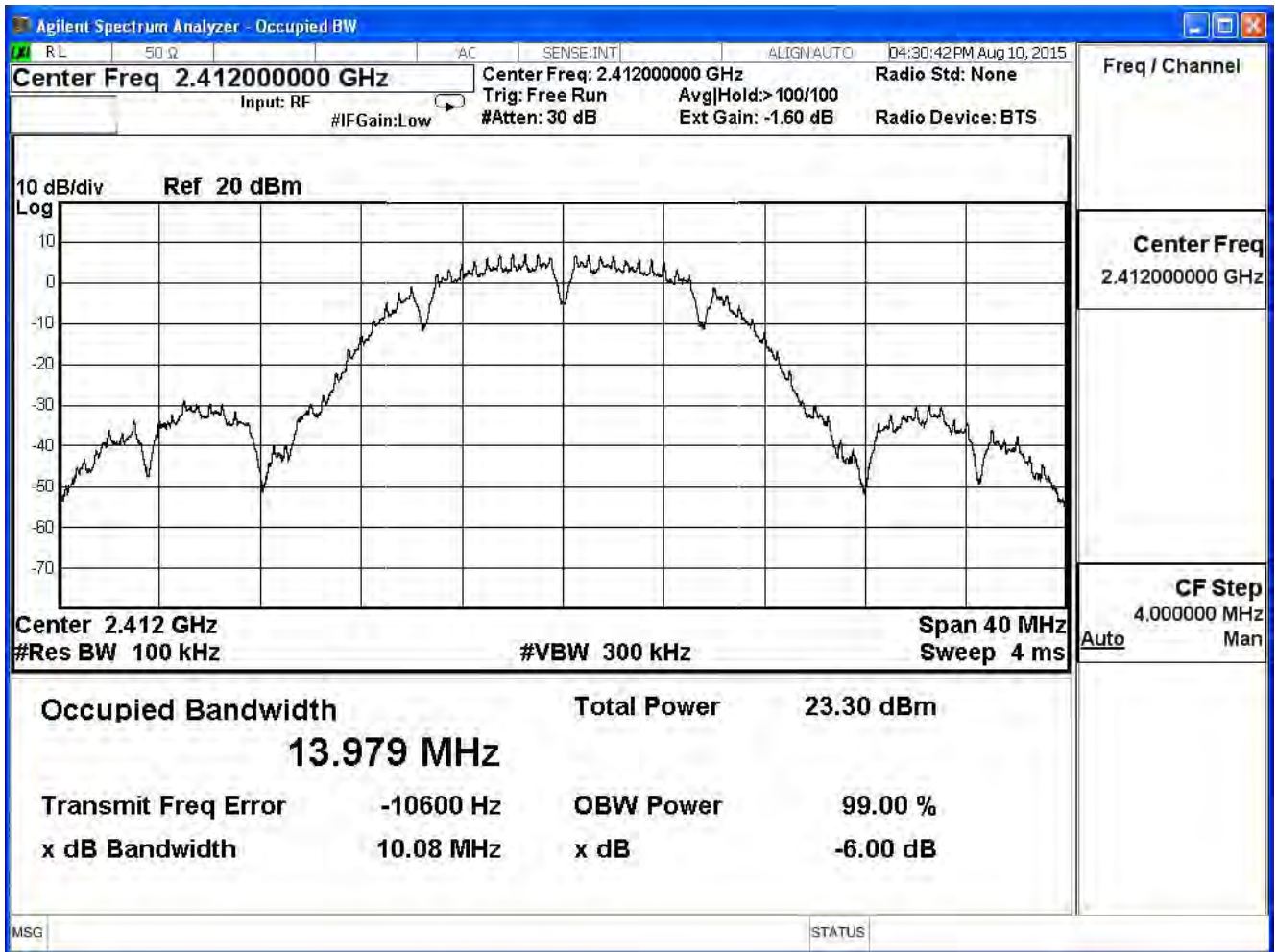

Channel 6 (2437MHz)

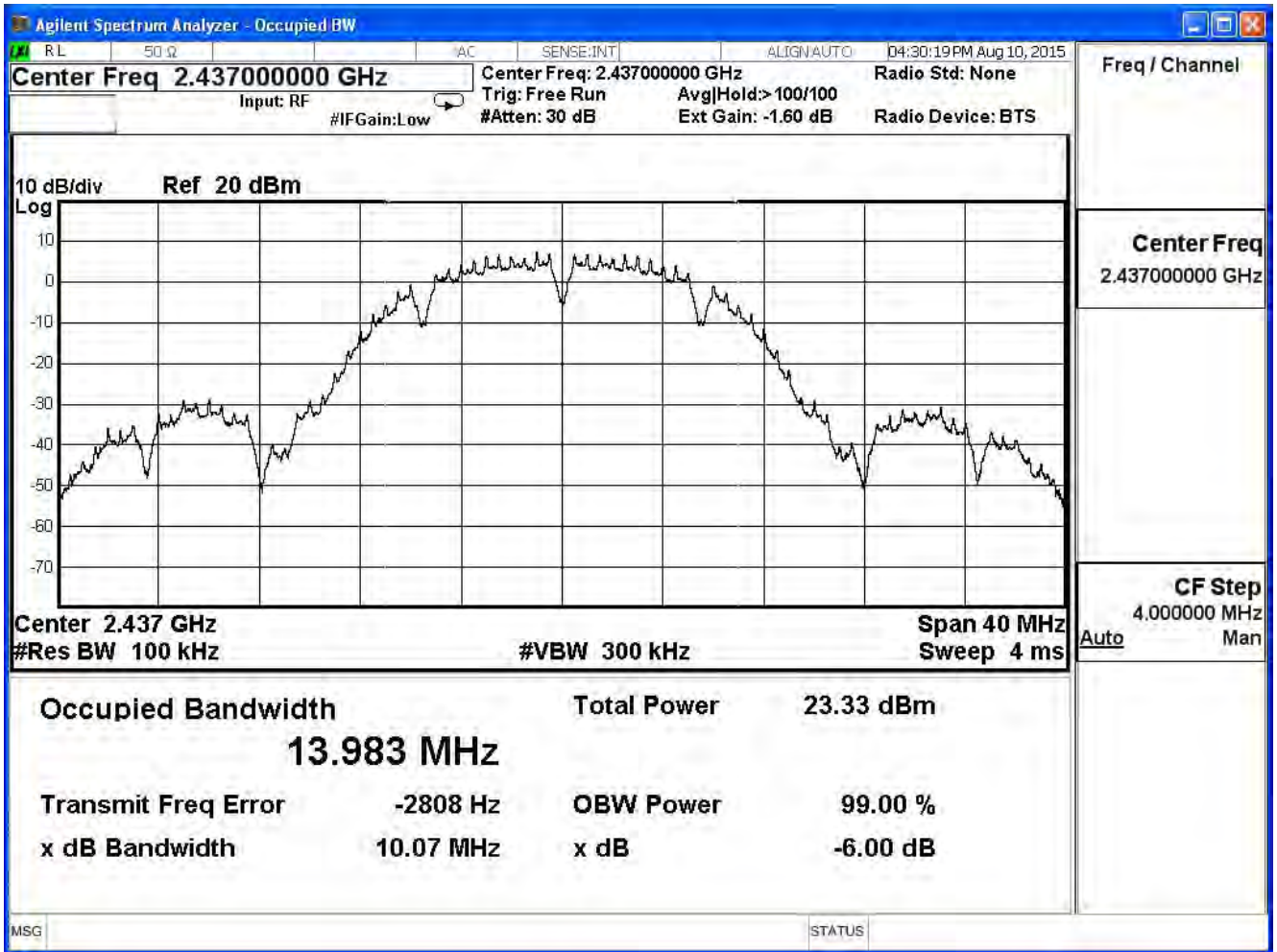

Channel 11 (2462MHz)

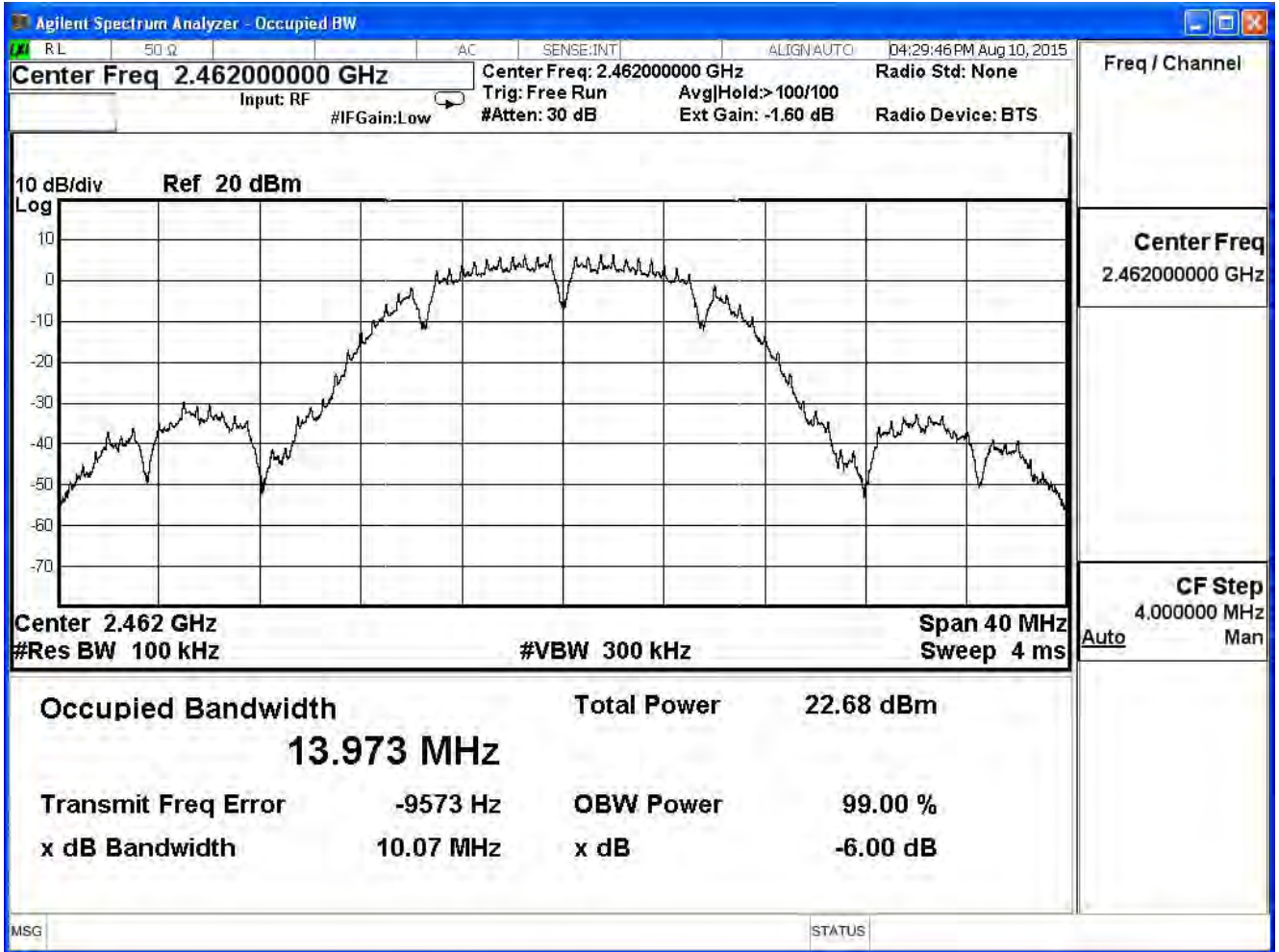

Product	ASUS SRT-AC1900 Wireless Smart Router		
Test Item	DTS Occupied Bandwidth		
Test Mode	Mode 1: Tx- AUX Antenna (AD891M21)		
Date of Test	2015/08/10	Test Site	SR7

IEEE 802.11g (ANT 0)				
Channel No.	Frequency (MHz)	Measurement Level (MHz)	Required Limit (MHz)	Result
1	2412	16.32	≥ 0.5	Pass
6	2437	16.31	≥ 0.5	Pass
11	2462	16.34	≥ 0.5	Pass

Channel 1 (2412MHz)

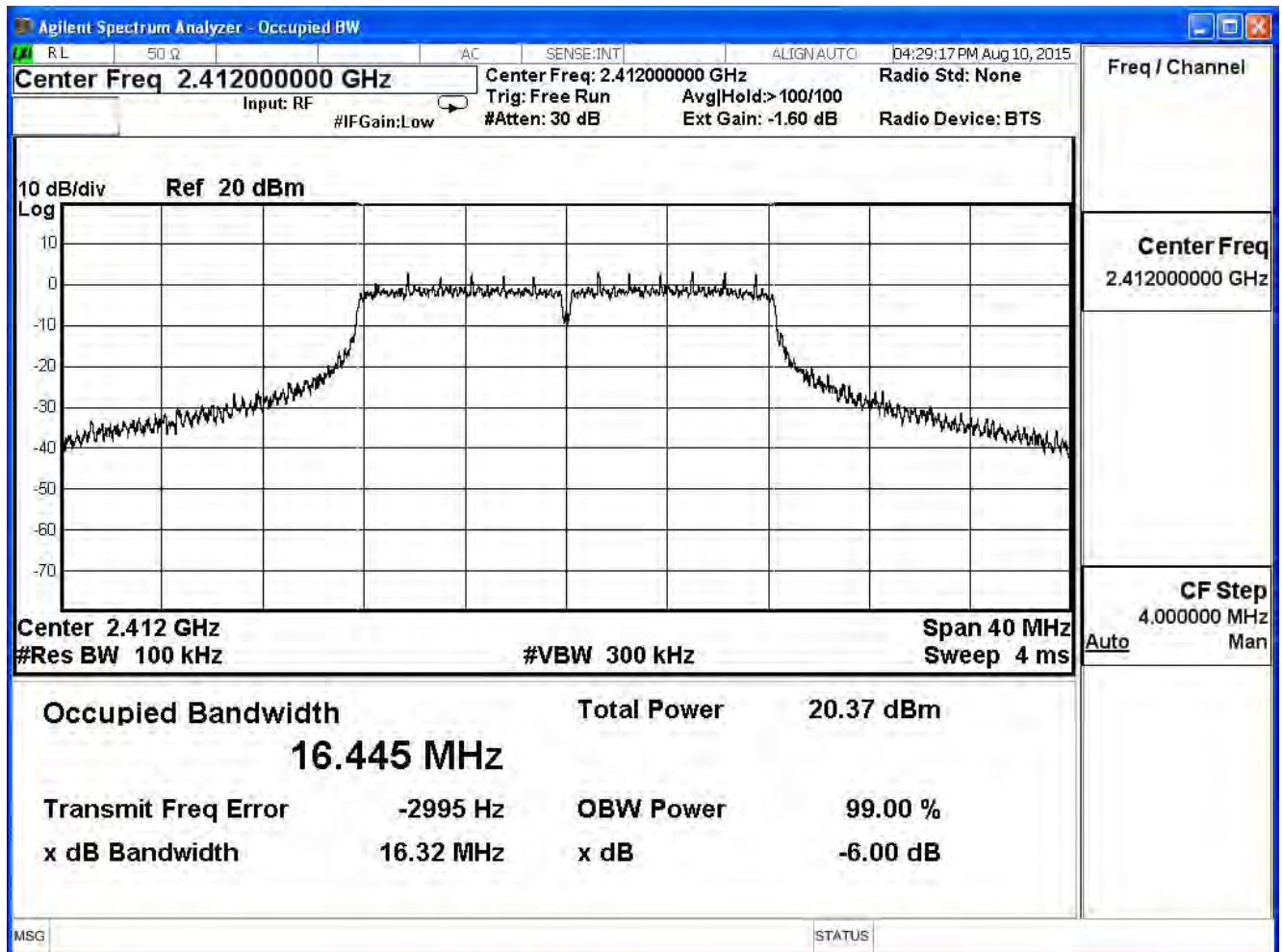

Channel 6 (2437MHz)

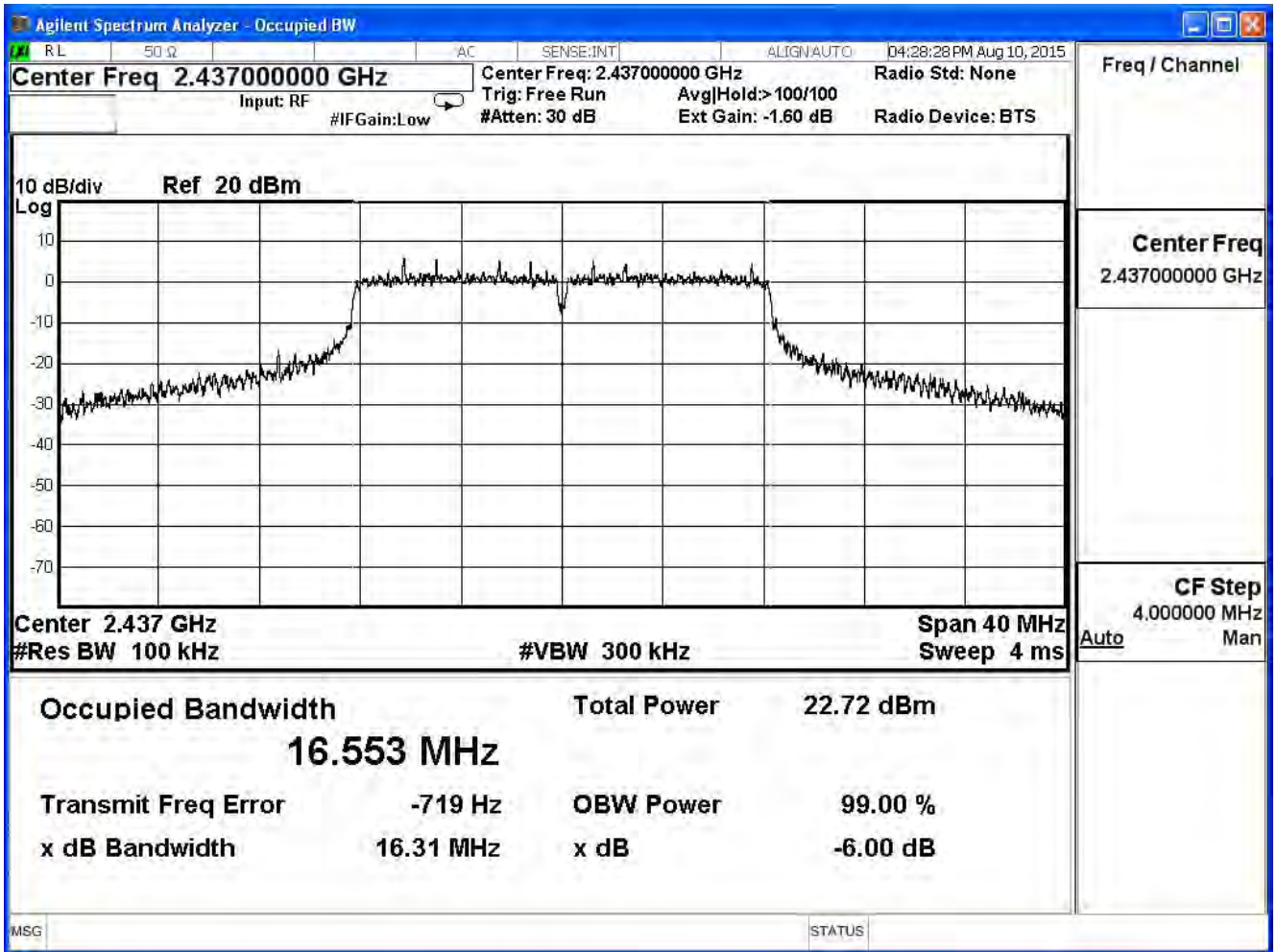

Channel 11 (2462MHz)

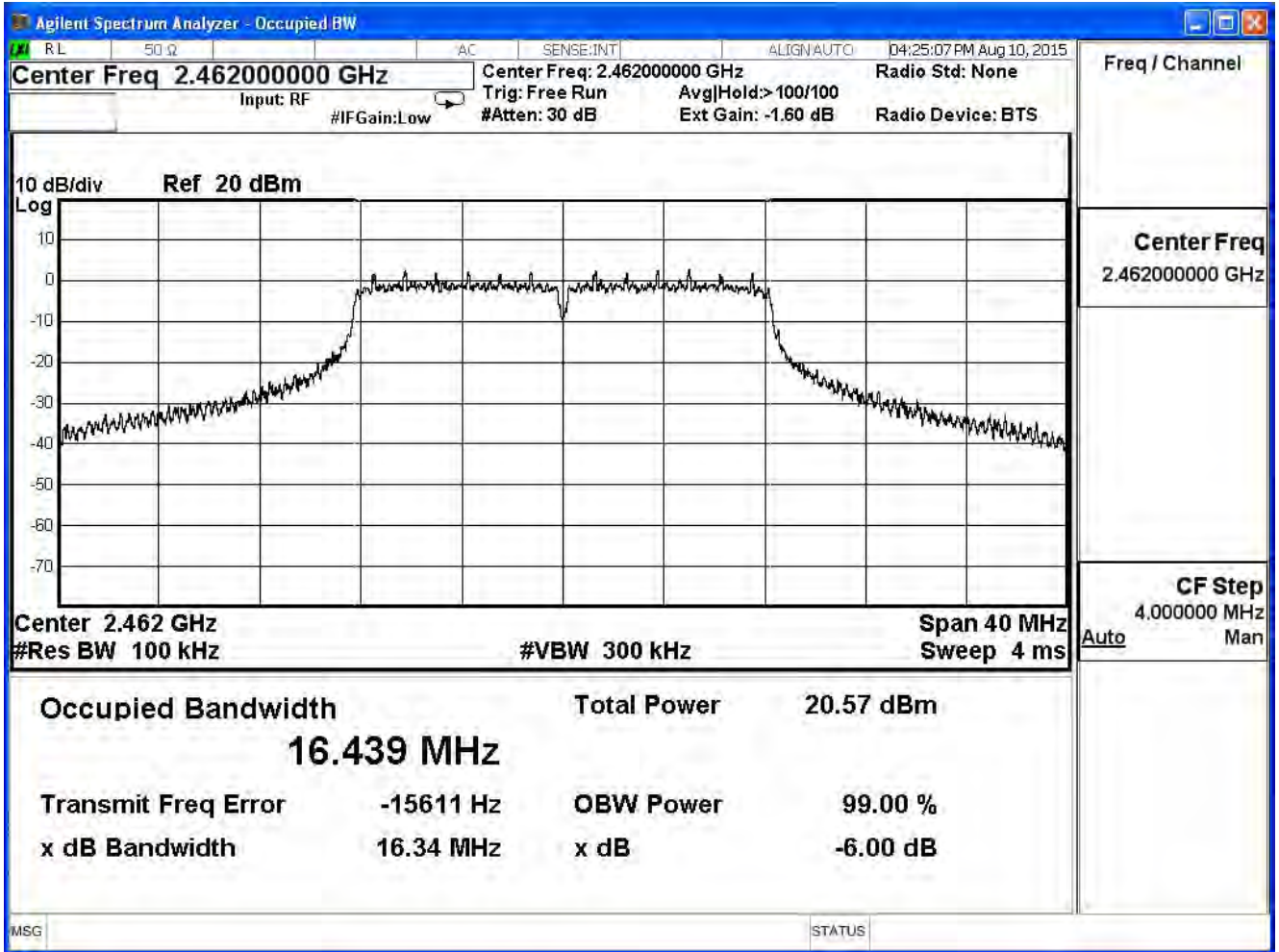

Product	ASUS SRT-AC1900 Wireless Smart Router		
Test Item	DTS Occupied Bandwidth		
Test Mode	Mode 1: Tx- AUX Antenna (AD891M21)		
Date of Test	2015/08/10	Test Site	SR7

IEEE 802.11n (20MHz) (ANT 0)				
Channel No.	Frequency (MHz)	Measurement Level (MHz)	Required Limit (MHz)	Result
1	2412	17.56	≥ 0.5	Pass
6	2437	17.31	≥ 0.5	Pass
11	2462	17.28	≥ 0.5	Pass

Channel 1 (2412MHz)

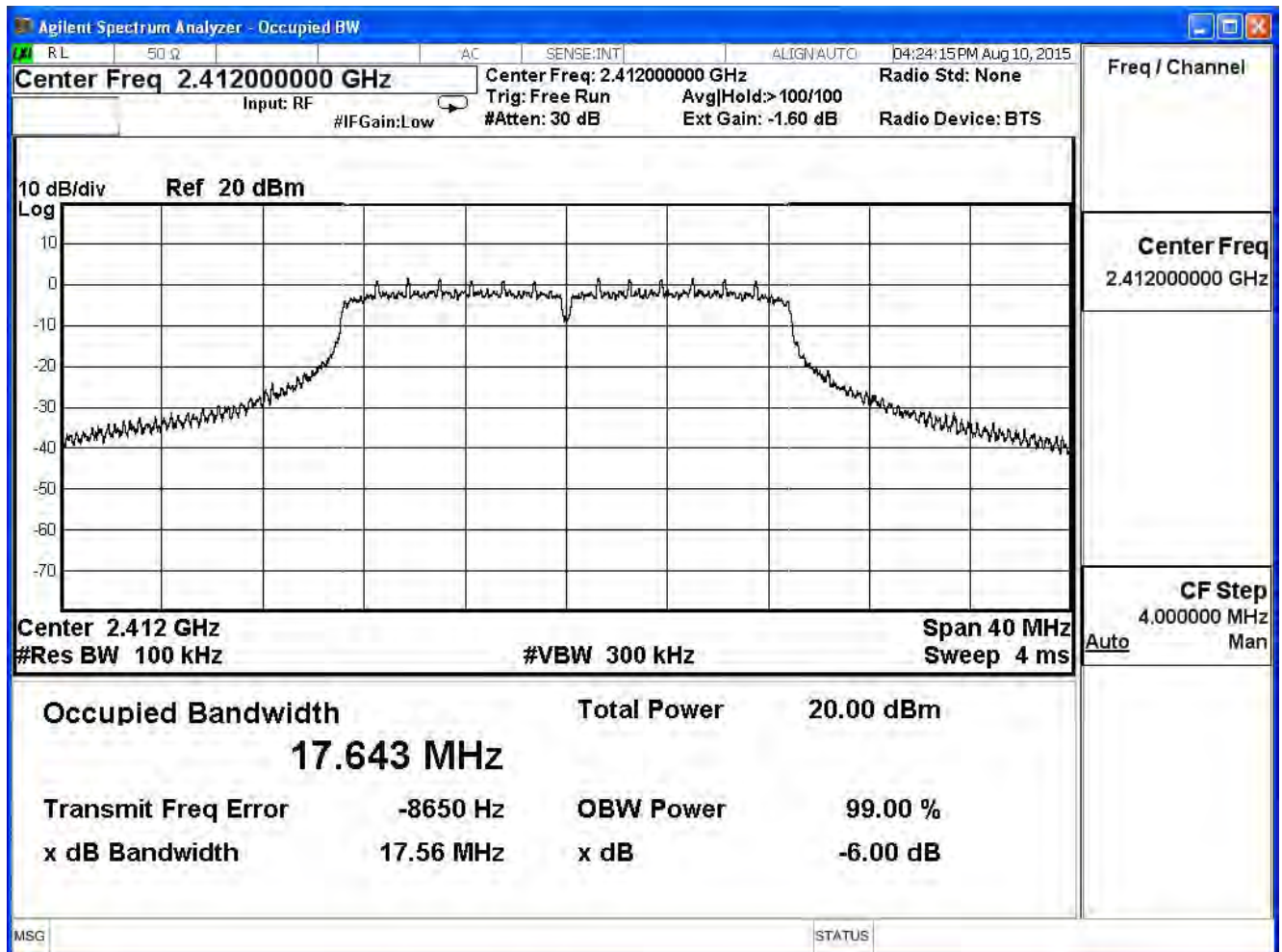

Channel 6 (2437MHz)

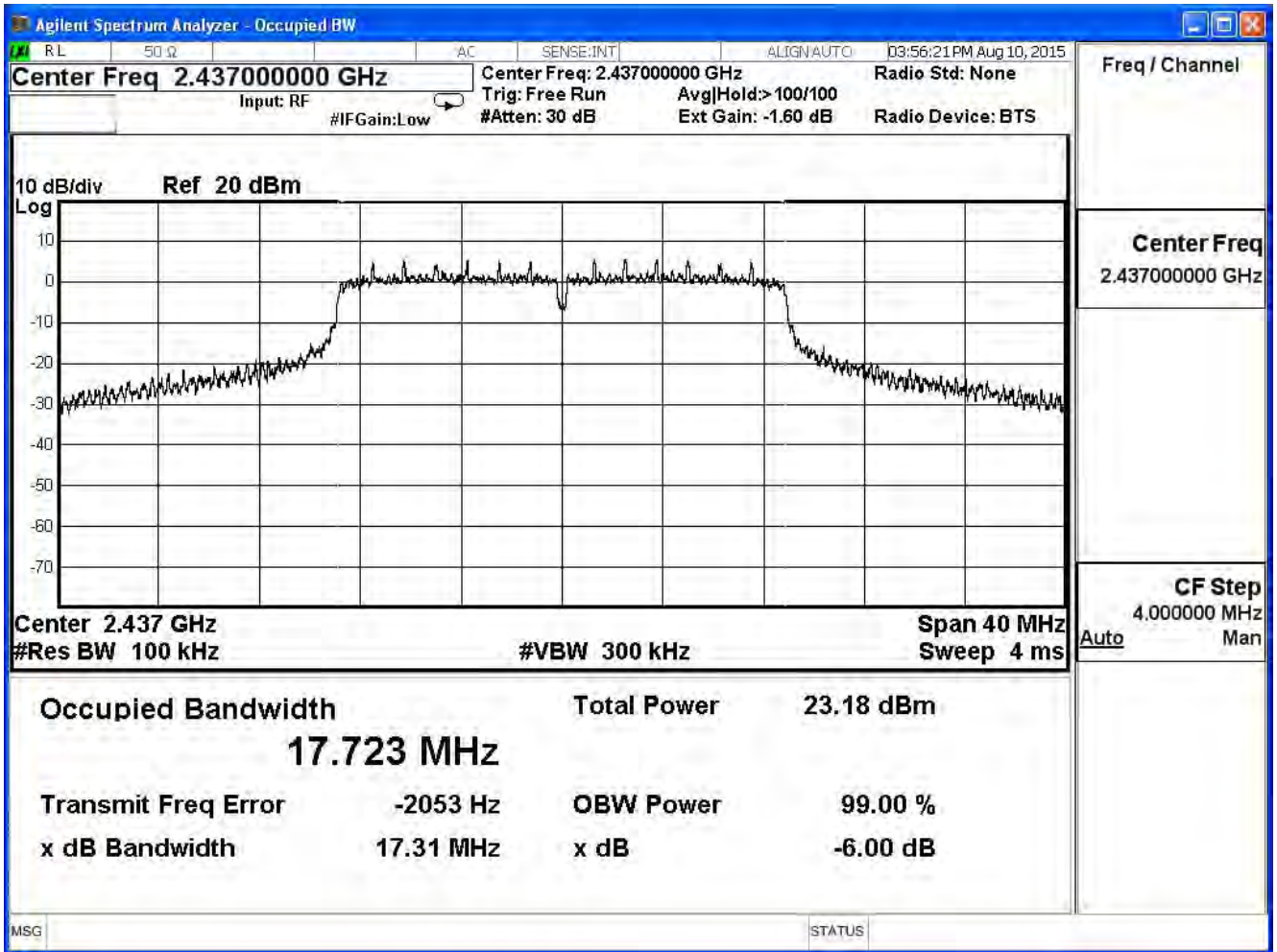

Channel 11 (2462MHz)

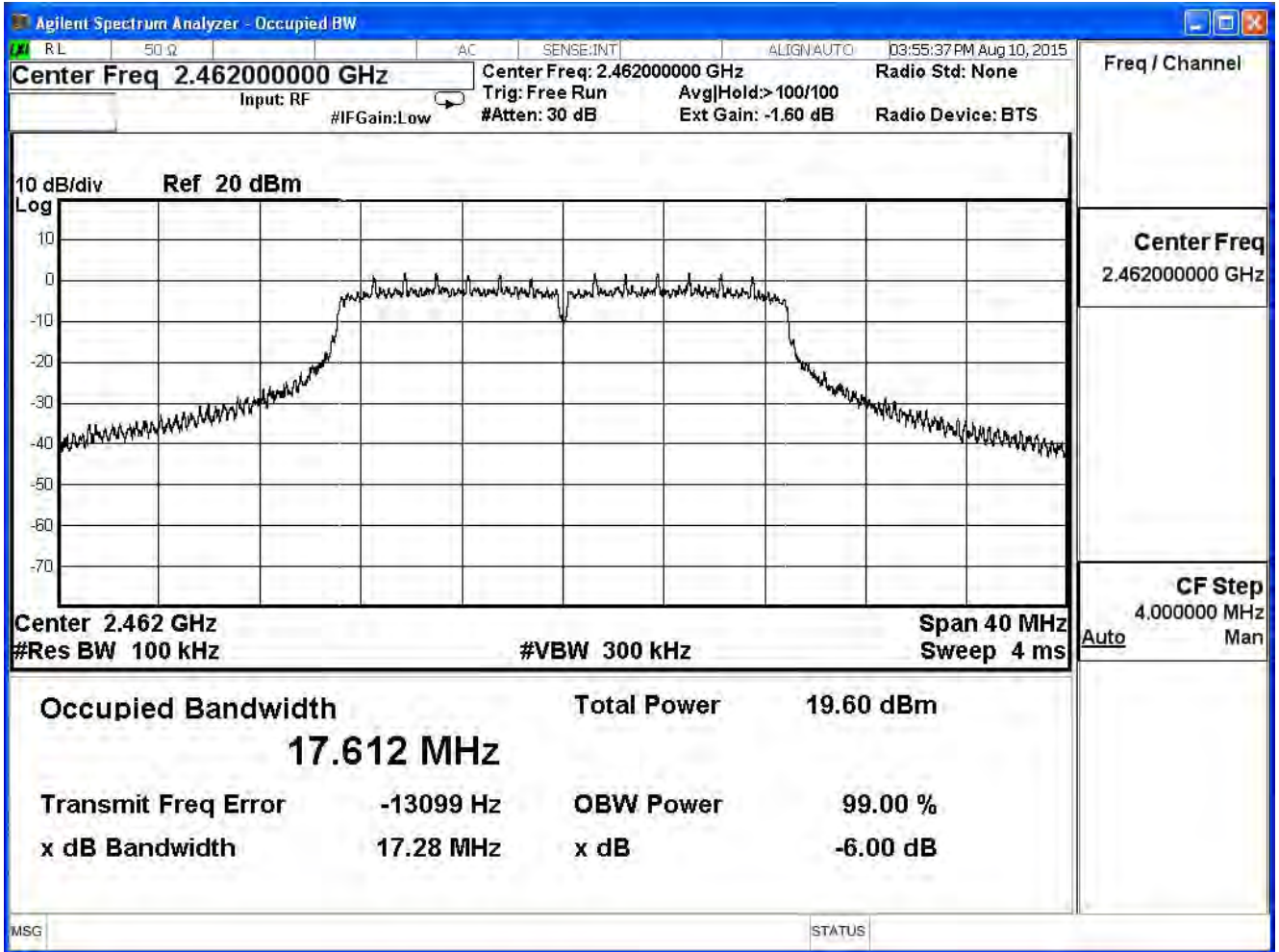

Product	ASUS SRT-AC1900 Wireless Smart Router		
Test Item	DTS Occupied Bandwidth		
Test Mode	Mode 1: Tx- AUX Antenna (AD891M21)		
Date of Test	2015/08/10	Test Site	SR7

IEEE 802.11n (40MHz) (ANT 0)				
Channel No.	Frequency (MHz)	Measurement Level (MHz)	Required Limit (MHz)	Result
3	2422	35.60	≥ 0.5	Pass
6	2437	35.14	≥ 0.5	Pass
9	2452	35.67	≥ 0.5	Pass

Channel 3 (2422MHz)

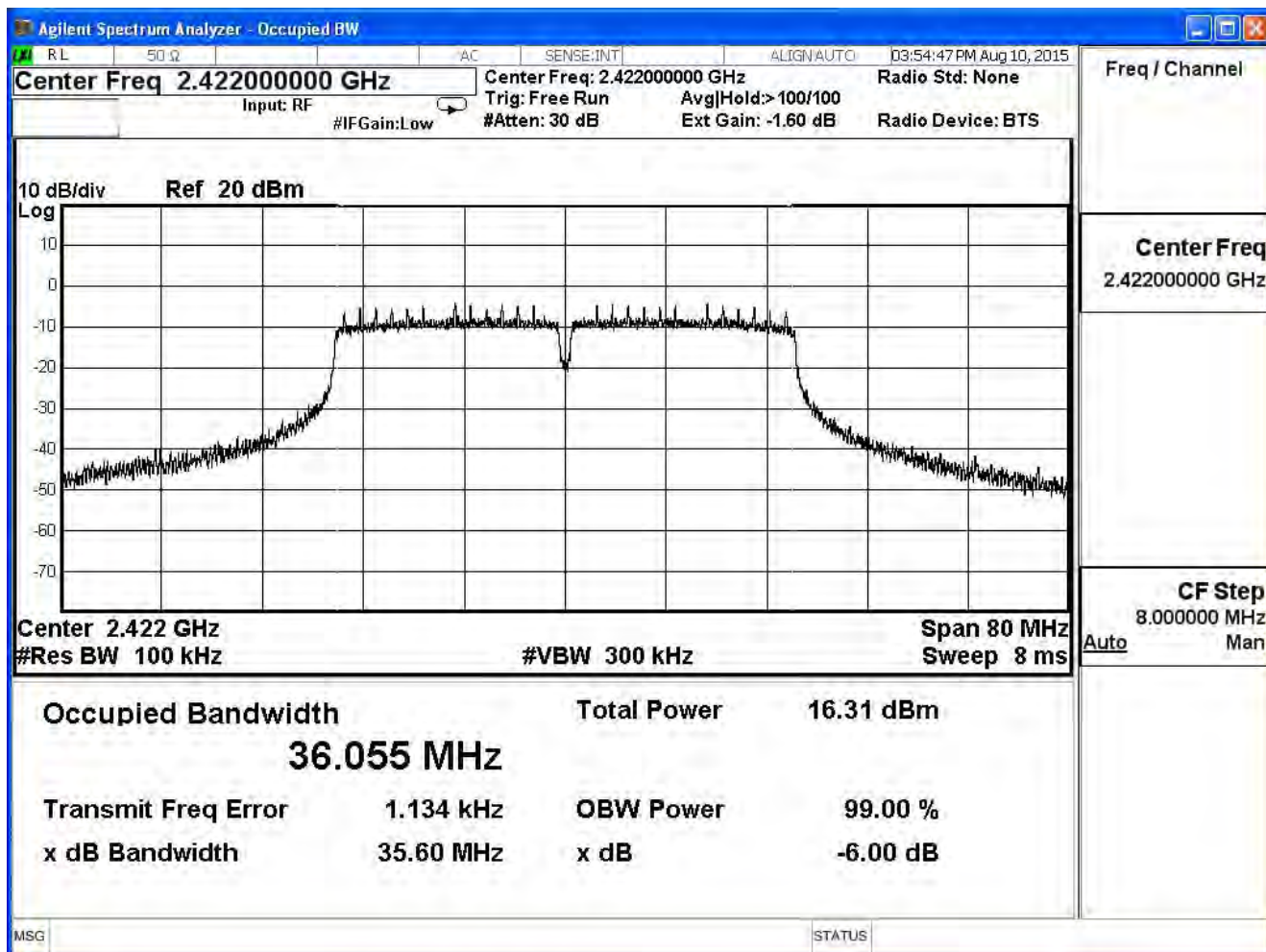

Channel 6 (2437MHz)

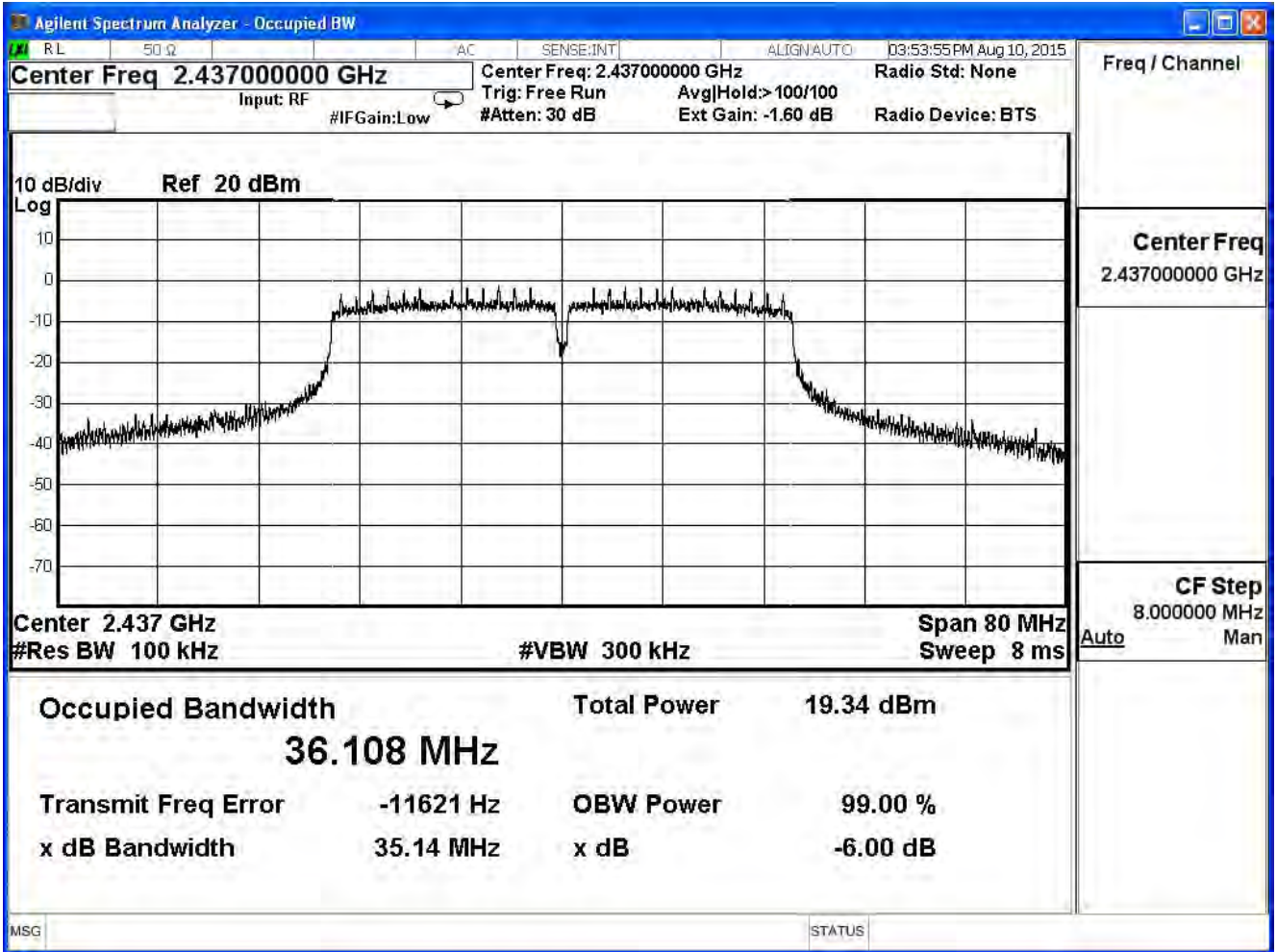

Channel 9 (2452MHz)

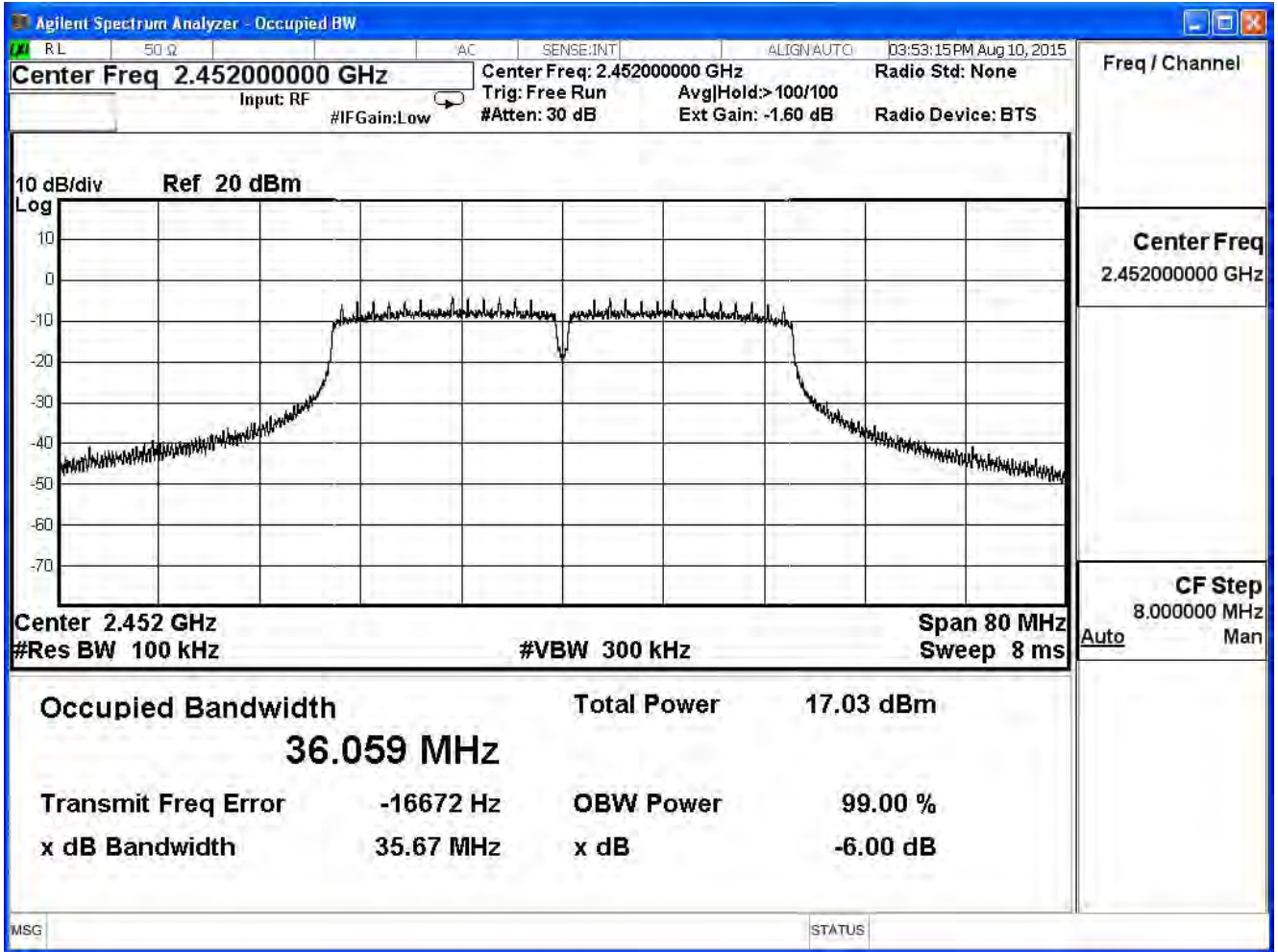

8. Occupied Bandwidth

8.1. Test Equipment

The following test equipments are used during the test:

Occupied Bandwidth / SR7

Instrument	Manufacturer	Model No.	Serial No	Next Cal. Date
Spectrum Analyzer	Agilent	N9010A-EXA	US47140172	2016/07/13

Note: 1. All equipments that need to calibrate are with calibration period of 1 year.

8.2. Test Setup

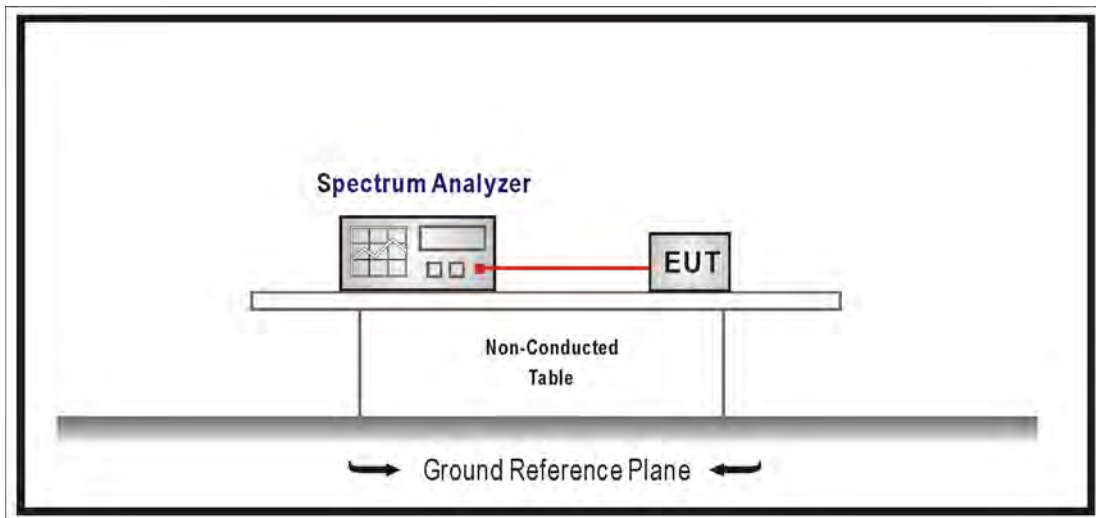

8.3. Test Procedures

The EUT was setup according to ANSI C63.10:2013; tested according to DTS test procedure section 8.1 of KDB558074 v03r02 for compliance to FCC 47CFR 15.247 requirements. Set RBW = 100KHz, VBW \geq 3xRBW, Sweep time=Auto, Set Peak detector.

8.4. Limits

NA

8.5. Test Specification

According to FCC Part 15 Subpart C Paragraph 15.247: 2014

8.6. Uncertainty

The measurement uncertainty is defined as $\pm 150\text{Hz}$

8.7. Test Result

Product	ASUS SRT-AC1900 Wireless Smart Router		
Test Item	Occupied Bandwidth		
Test Mode	Mode 1: Tx- AUX Antenna (AD891M21)		
Date of Test	2015/08/10	Test Site	SR7

802.11 b (ANT 0)				
Channel No.	Frequency (MHz)	Measurement Level (MHz)	Required Limit (MHz)	Result
1	2412	14.13	--	Pass
6	2437	14.01	--	Pass
11	2462	13.99	--	Pass

Channel 1 (2412MHz)

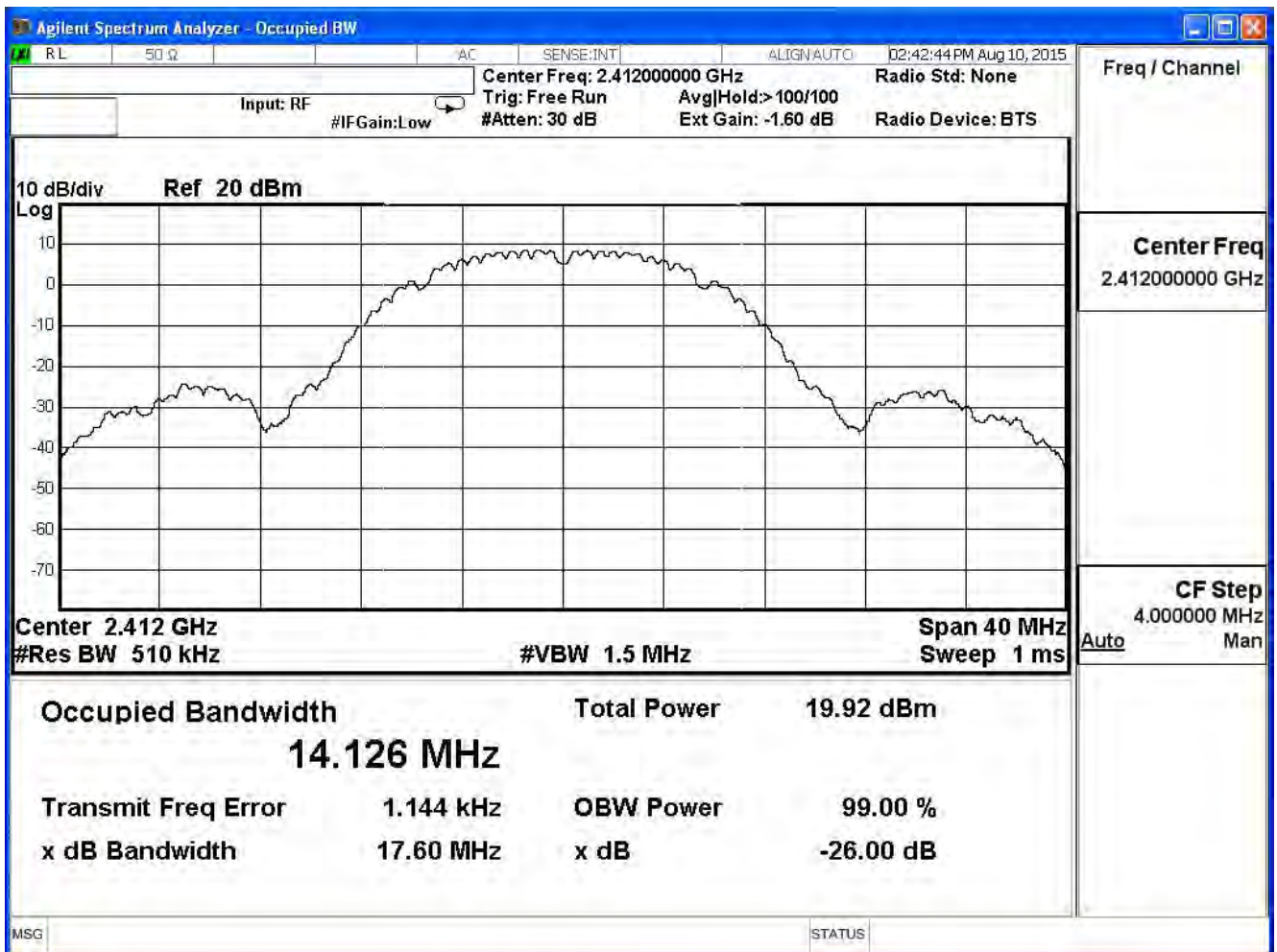

Channel 6 (2437MHz)

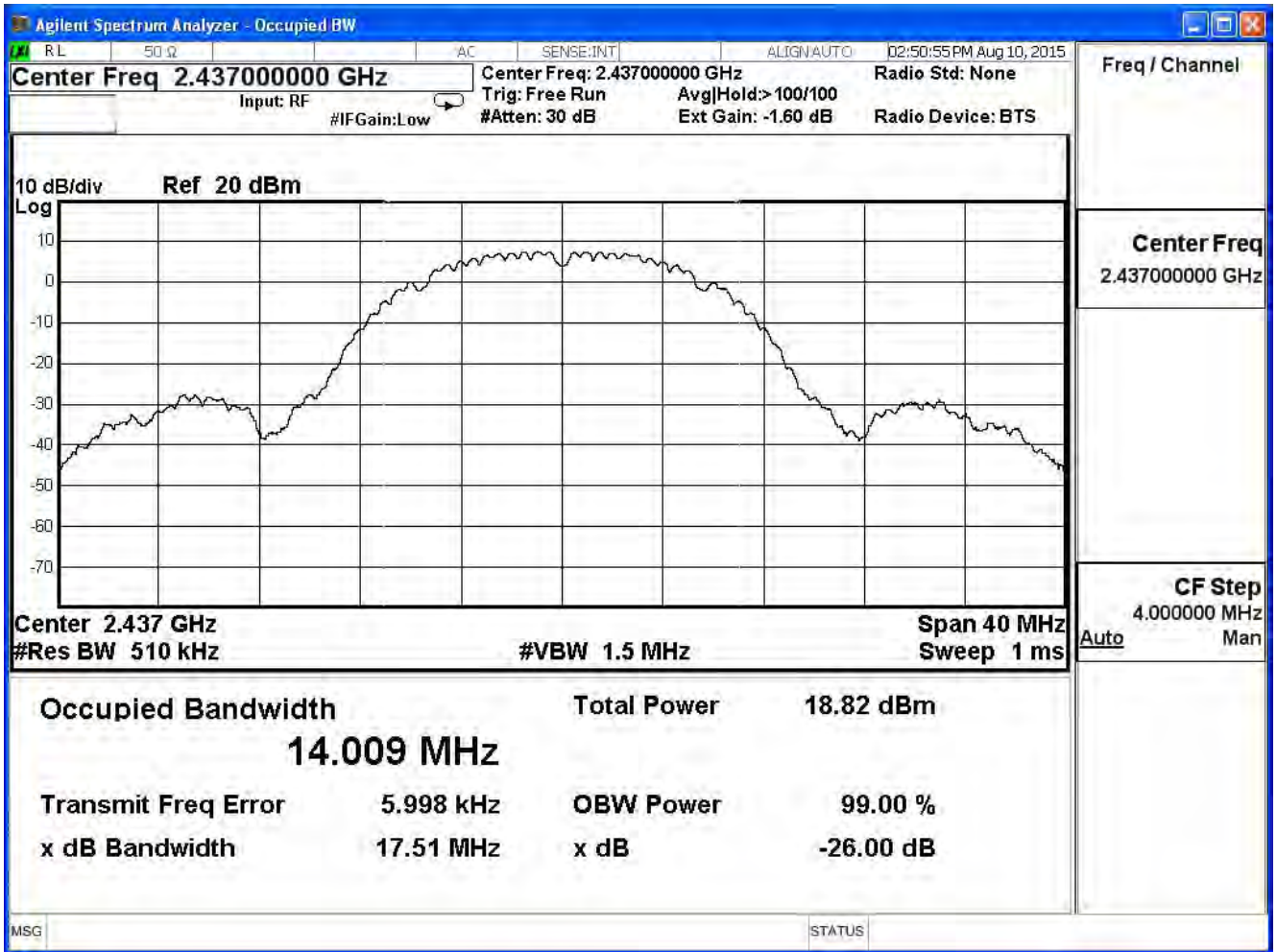

Channel 11 (2462MHz)

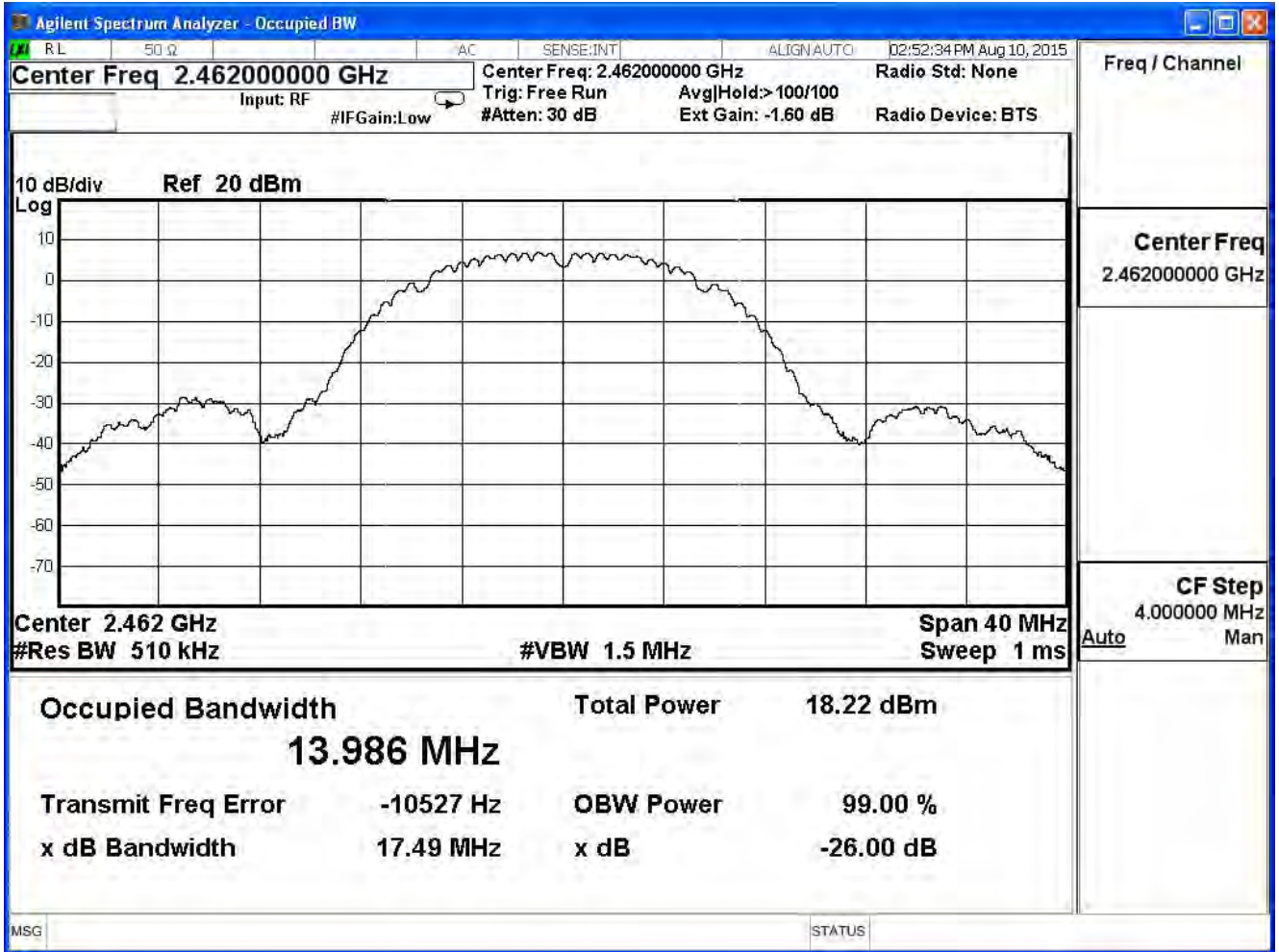

Product	ASUS SRT-AC1900 Wireless Smart Router		
Test Item	Occupied Bandwidth		
Test Mode	Mode 1: Tx- AUX Antenna (AD891M21)		
Date of Test	2015/08/10	Test Site	SR7

IEEE 802.11g (ANT 0)				
Channel No.	Frequency (MHz)	Measurement Level (MHz)	Required Limit (MHz)	Result
1	2412	17.13	--	Pass
6	2437	17.44	--	Pass
11	2462	17.03	--	Pass

Channel 1 (2412MHz)

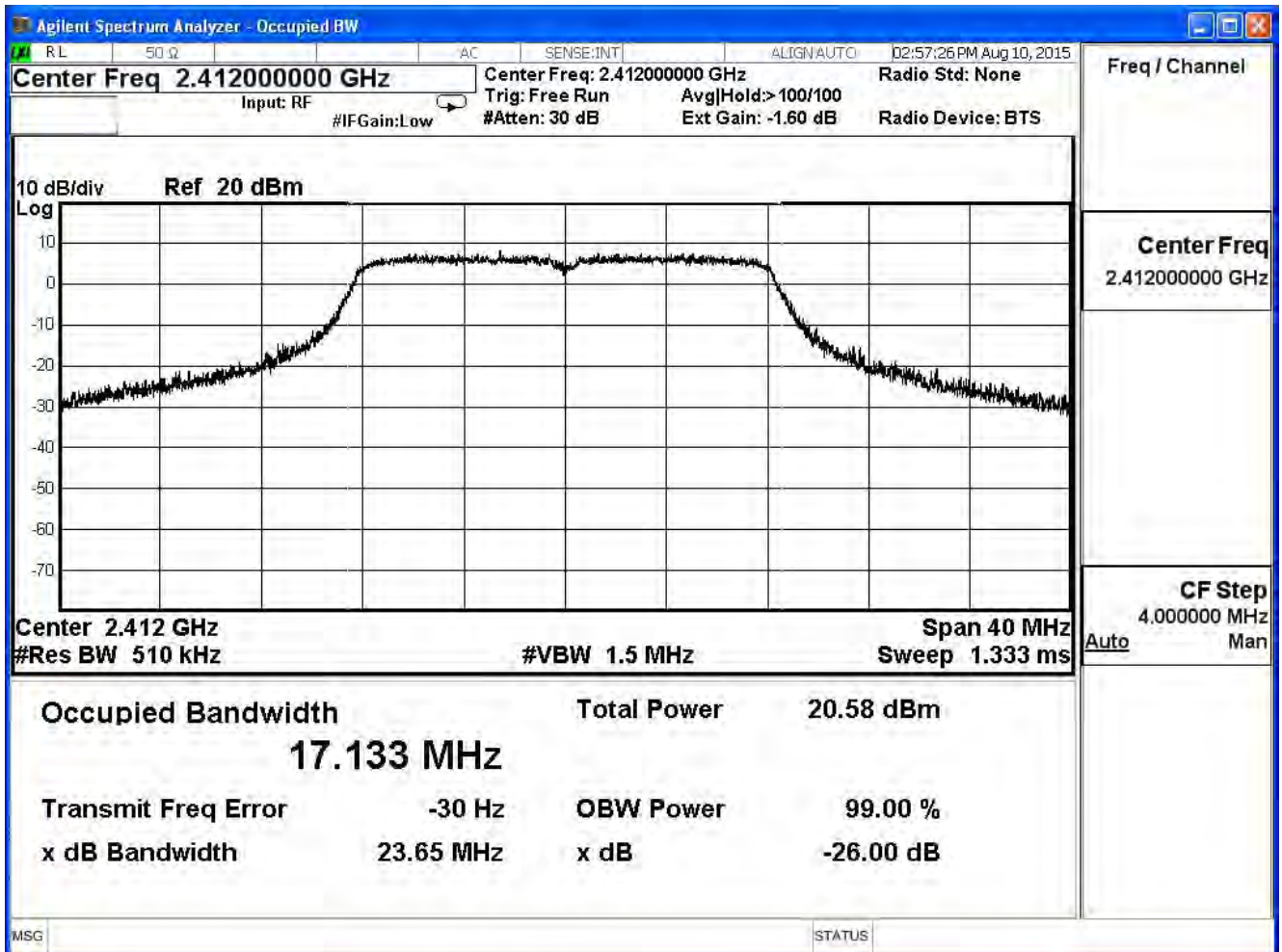

Channel 6 (2437MHz)

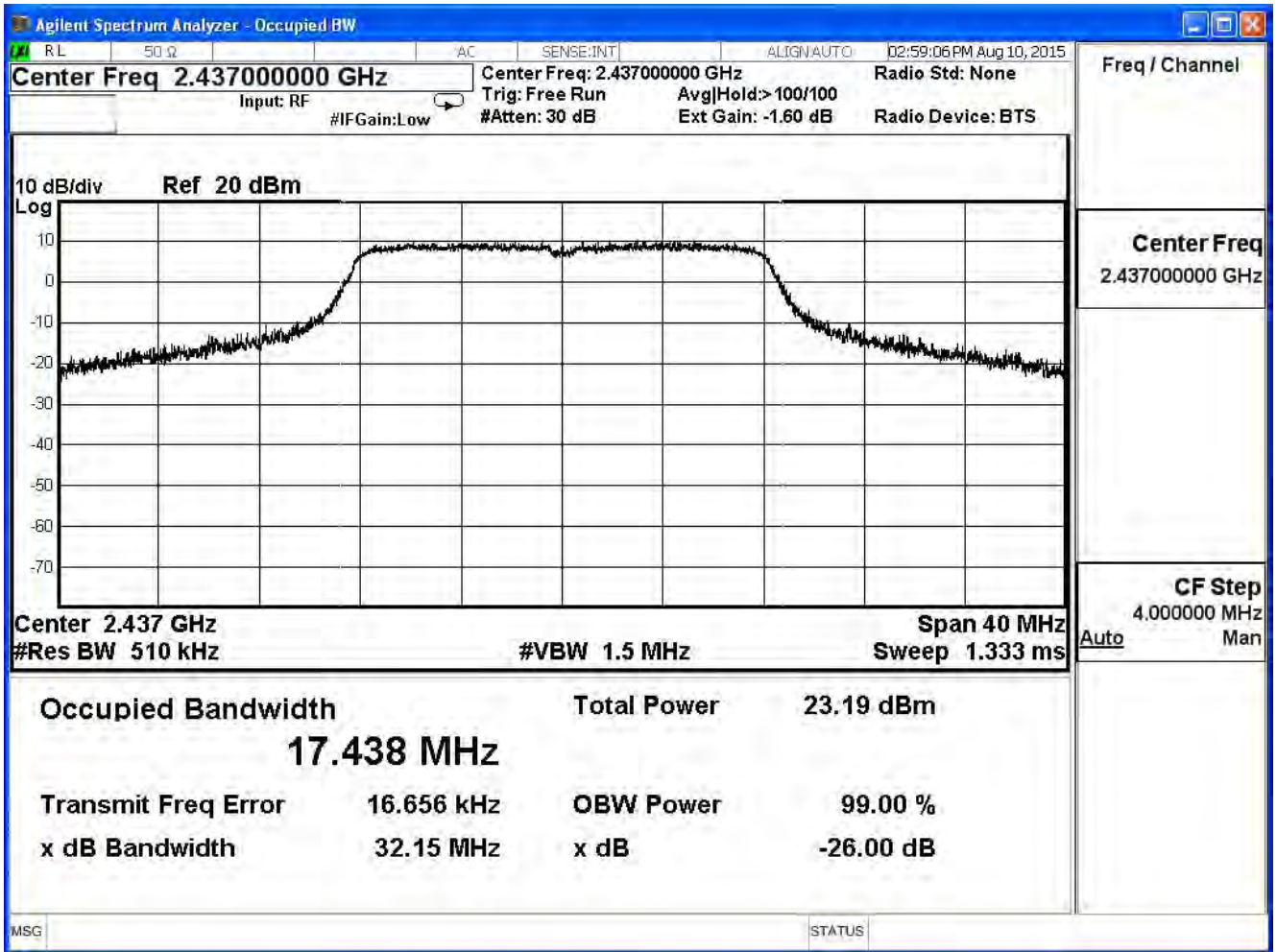

Channel 11 (2462MHz)

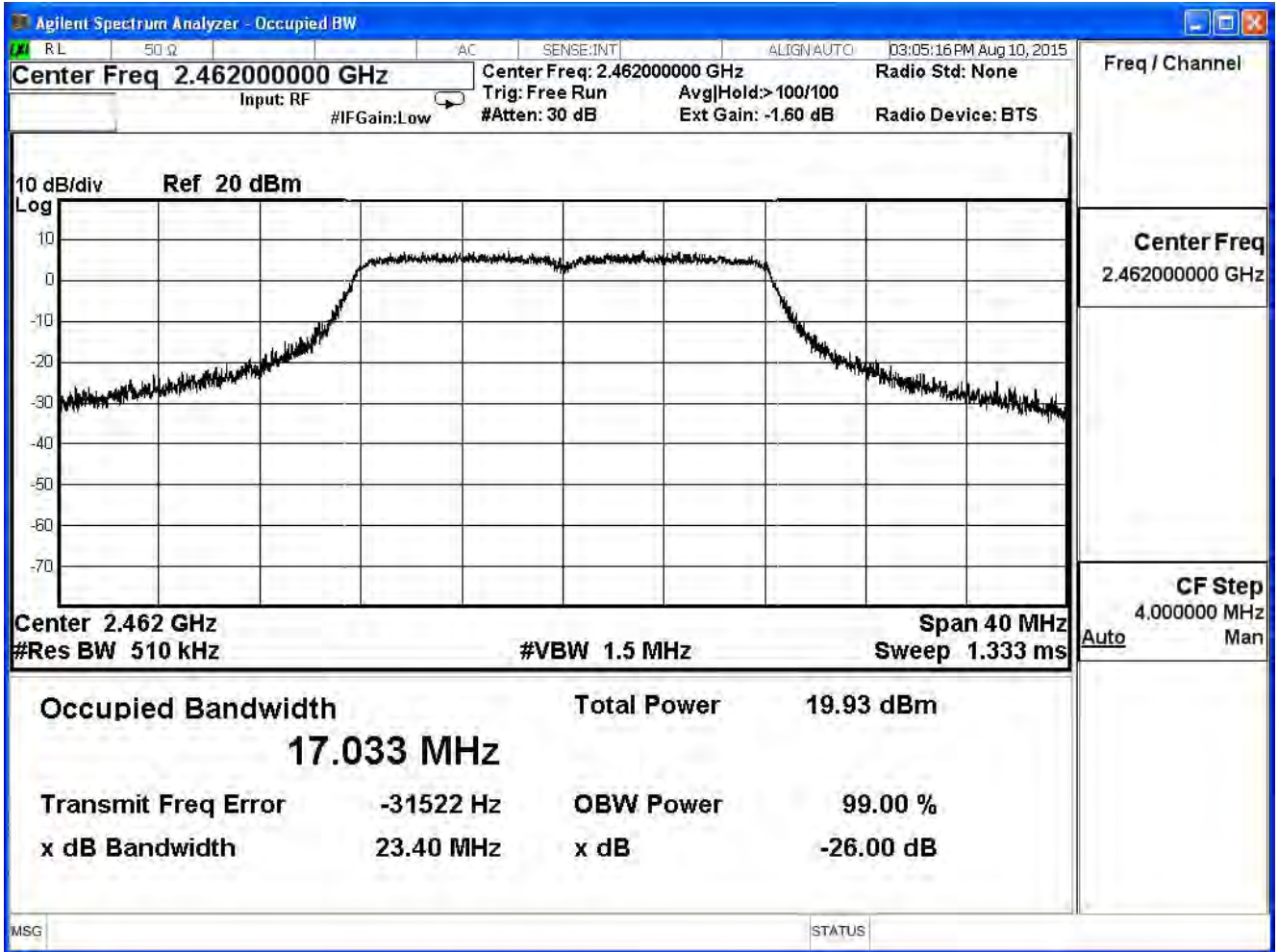

Product	ASUS SRT-AC1900 Wireless Smart Router		
Test Item	Occupied Bandwidth		
Test Mode	Mode 1: Tx- AUX Antenna (AD891M21)		
Date of Test	2015/08/10	Test Site	SR7

IEEE 802.11n (20MHz) (ANT 0)				
Channel No.	Frequency (MHz)	Measurement Level (MHz)	Required Limit (MHz)	Result
1	2412	18.22	--	Pass
6	2437	18.56	--	Pass
11	2462	18.19	--	Pass

Channel 1 (2412MHz)

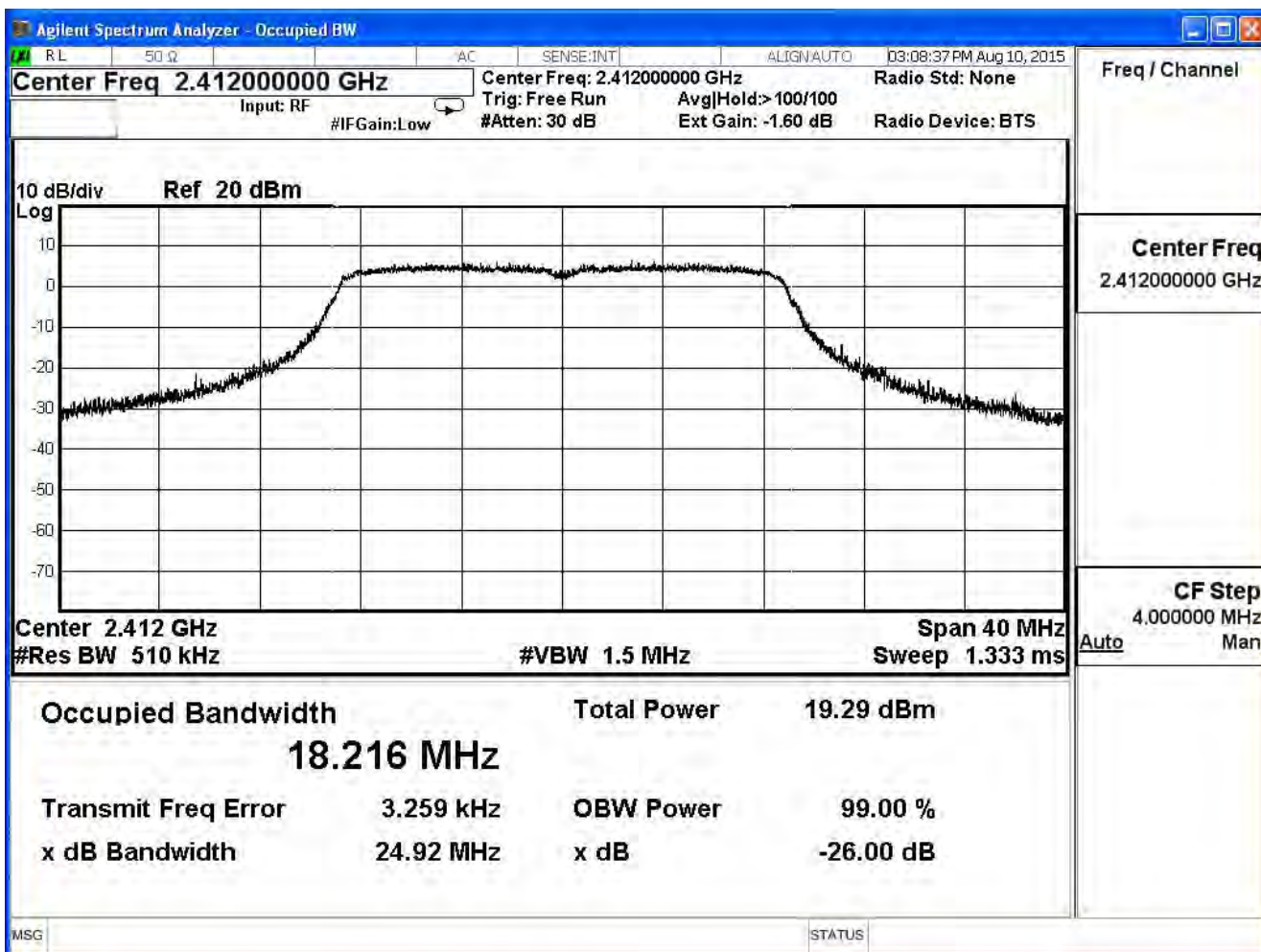

Channel 6 (2437MHz)

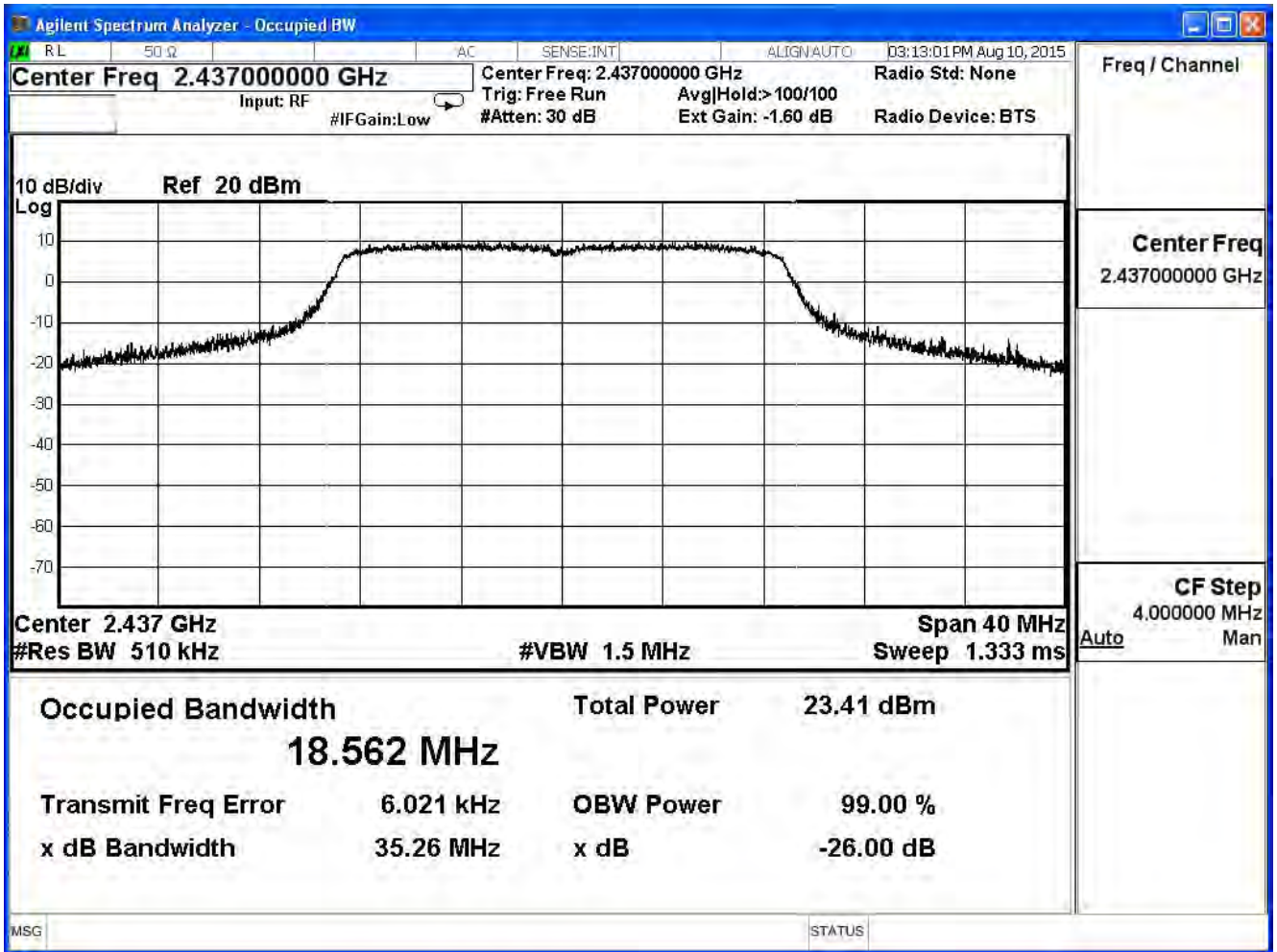

Channel 11 (2462MHz)

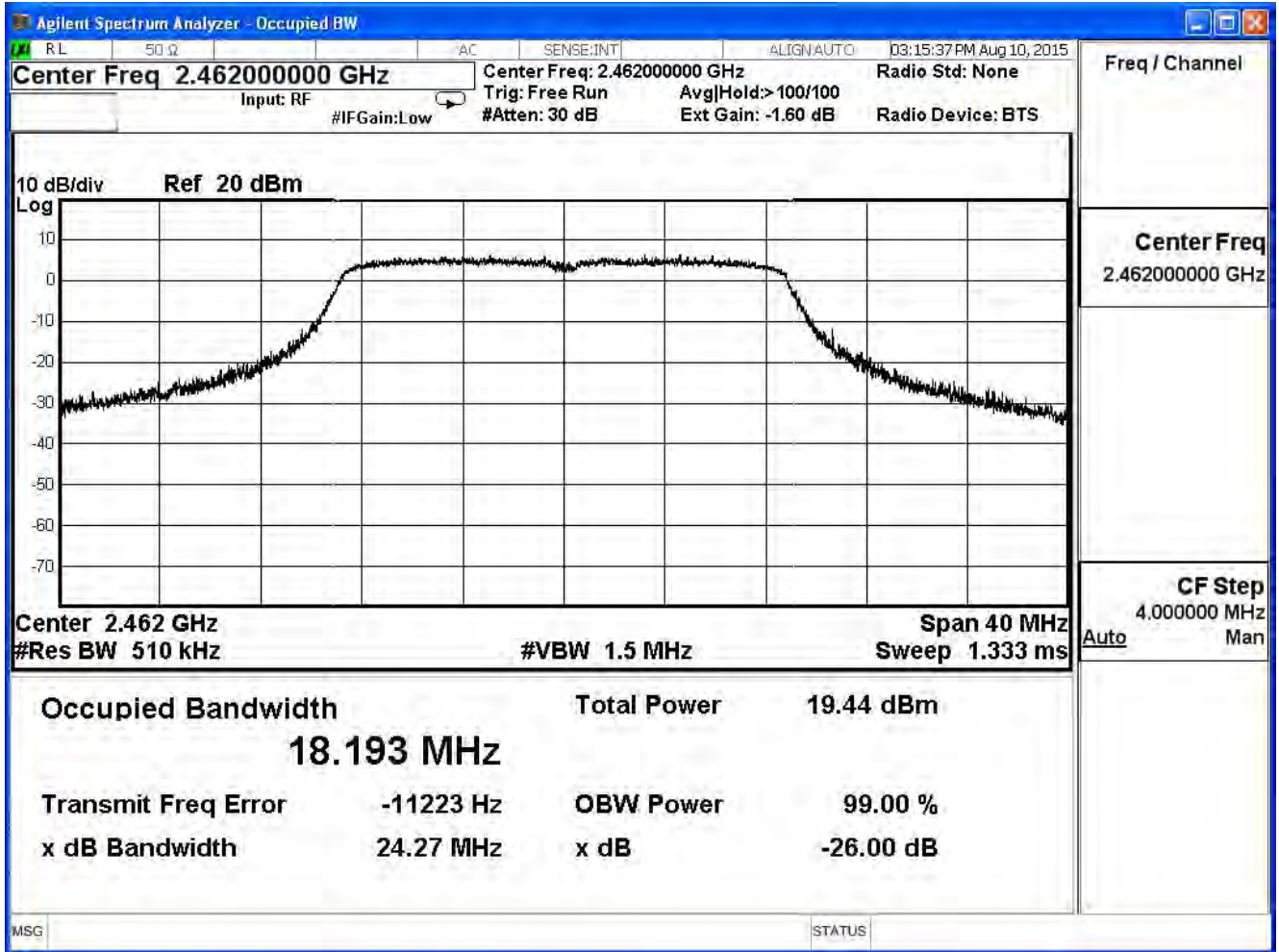

Product	ASUS SRT-AC1900 Wireless Smart Router		
Test Item	Occupied Bandwidth		
Test Mode	Mode 1: Tx- AUX Antenna (AD891M21)		
Date of Test	2015/08/10	Test Site	SR7

IEEE 802.11n (40MHz) (ANT 0)				
Channel No.	Frequency (MHz)	Measurement Level (MHz)	Required Limit (MHz)	Result
3	2422	36.37	--	Pass
6	2437	36.39	--	Pass
9	2452	36.32	--	Pass

Channel 3 (2422MHz)

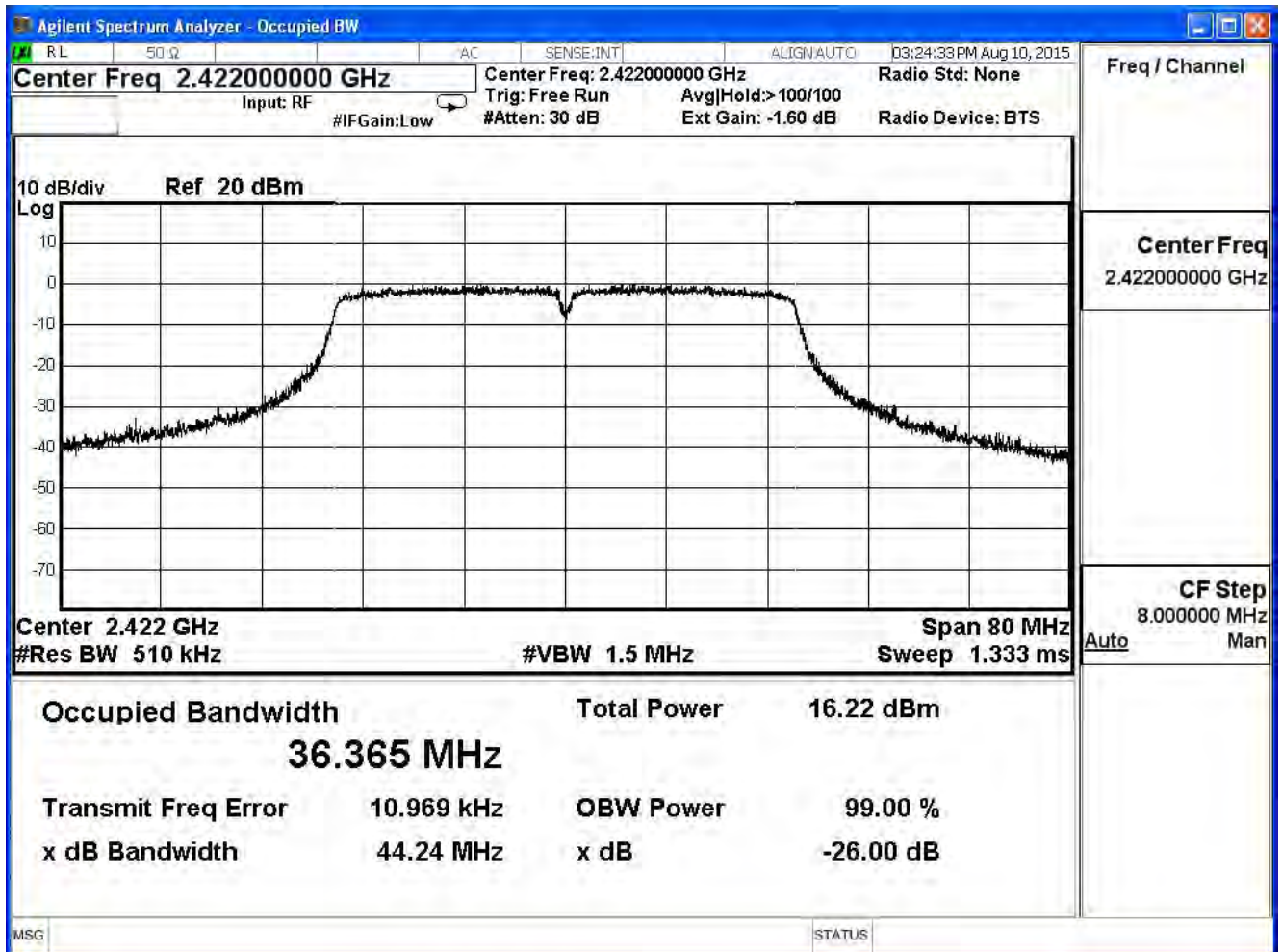

Channel 6 (2437MHz)

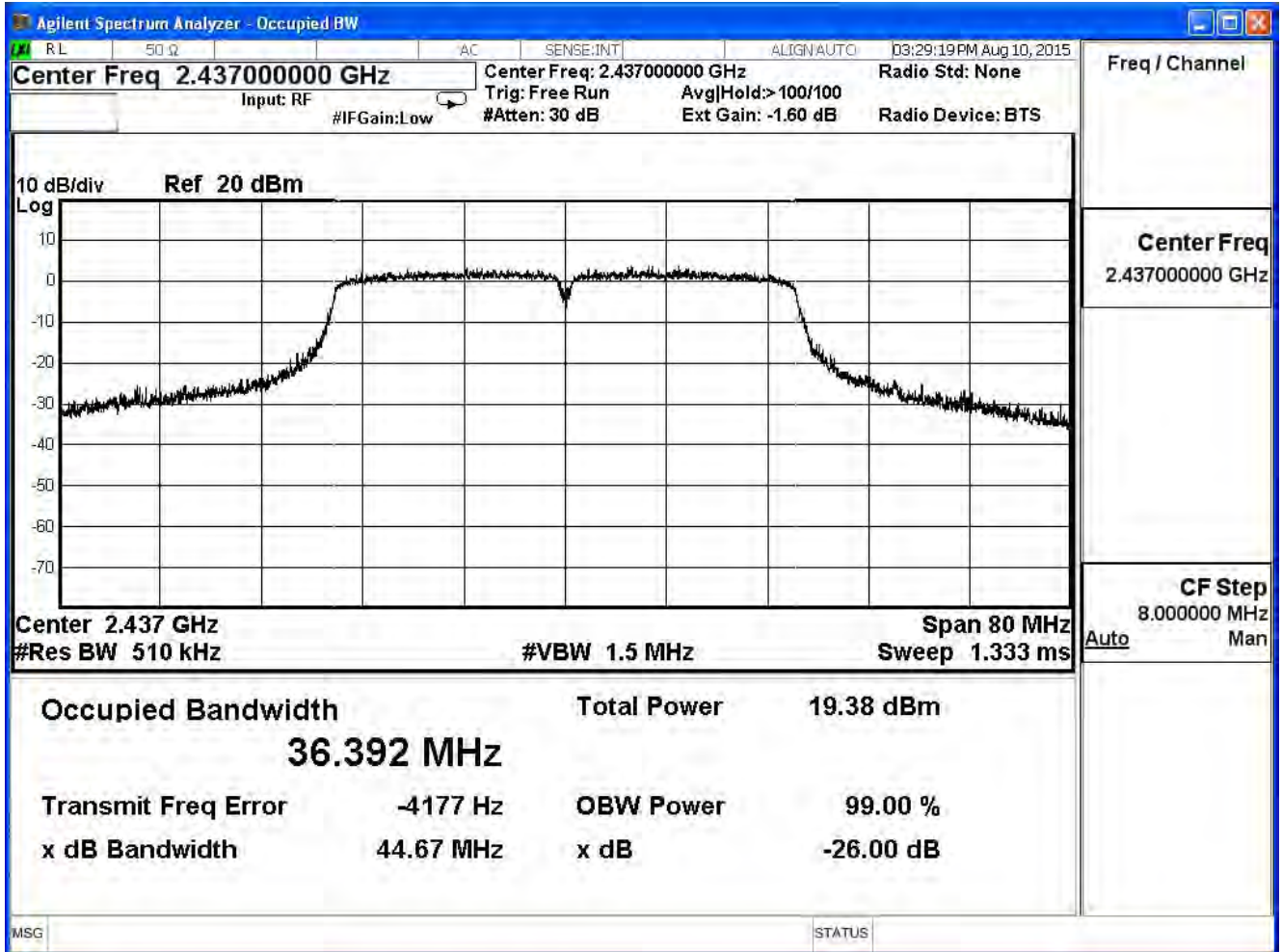

Channel 9 (2452MHz)

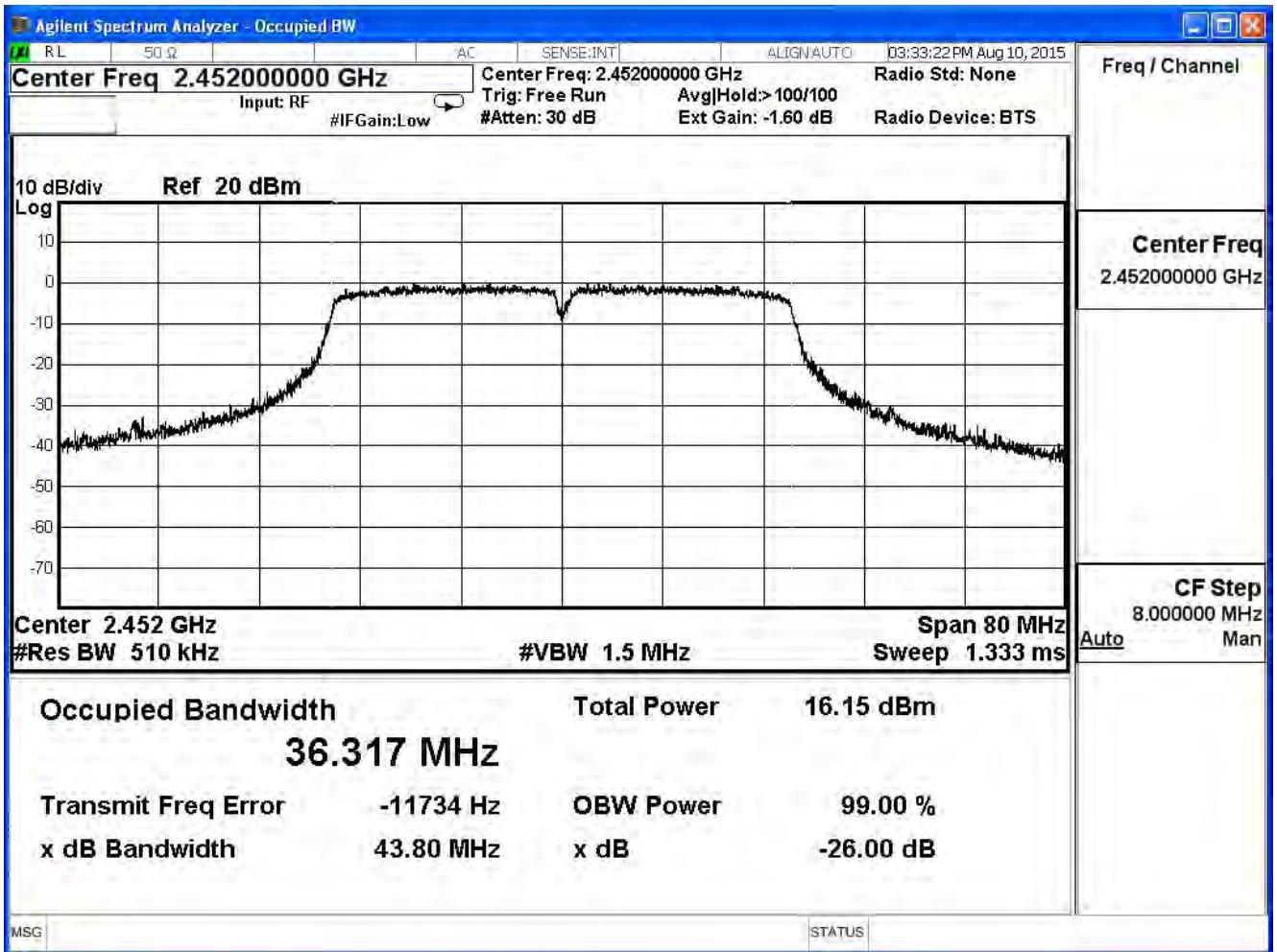

9. Power Density

9.1. Test Equipment

The following test equipment is used during the test:

Power Density / SR7

Instrument	Manufacturer	Model No.	Serial No	Next Cal. Date
Spectrum Analyzer	Agilent	N9010A-EXA	US47140172	2016/07/13

Note: 1. All equipments that need to calibrate are with calibration period of 1 year.

9.2. Test Setup

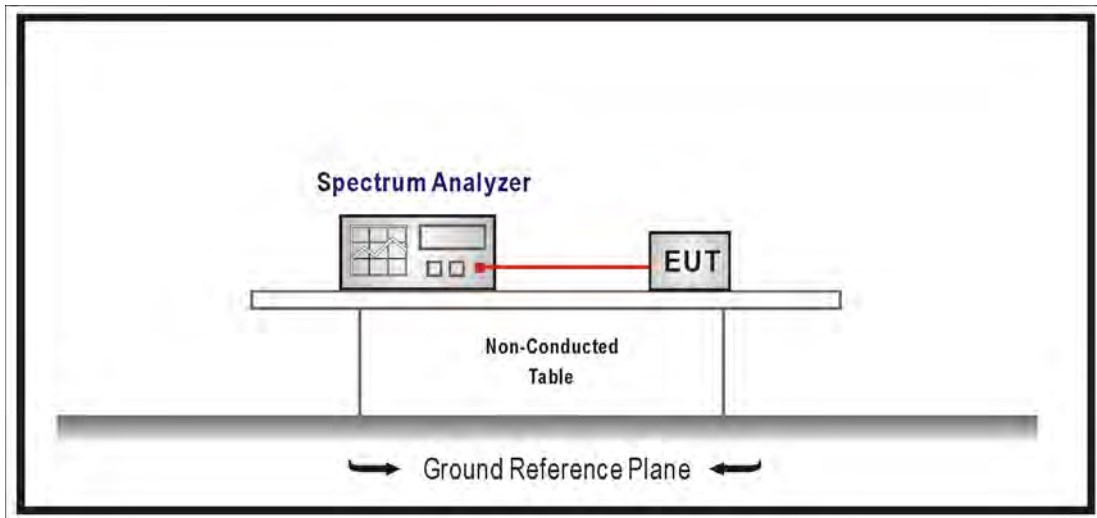

9.3. Limits

The peak power spectral density conducted from the intentional radiated to the antenna shall not be greater than +8dBm in any 3kHz band during any time interval of continuous transmission.

9.4. Test Procedures

The EUT was setup according to ANSI C63.10:2013; tested according to DTS test procedure section 10.2 of KDB558074 v03r02 for compliance to FCC 47CFR 15.247 requirements. Set 3KHz \leq RBW \leq 100 kHz, Set VBW \geq 3xRBW, Sweep time=Auto, Set Peak detector; The tested according to section E)c) of KDB662911 v02v01.

9.5. Test Specification

According to FCC Part 15 Subpart C Paragraph 15.247: 2014

9.6. Uncertainty

The measurement uncertainty is defined as ± 1.27 dB.

9.7. Test Result

Product	ASUS SRT-AC1900 Wireless Smart Router		
Test Item	Power Density		
Test Mode	Mode 1: Tx- AUX Antenna (AD891M21)		
Date of Test	2015/08/10	Test Site	SR7

IEEE 802.11b (ANT 0)				
Channel No.	Frequency (MHz)	Measure Level (dBm)	Limit (dBm)	Result
1	2412	-6.770	≤ 8	Pass
6	2437	-6.508	≤ 8	Pass
11	2462	-6.979	≤ 8	Pass

Channel 1 (2412MHz)

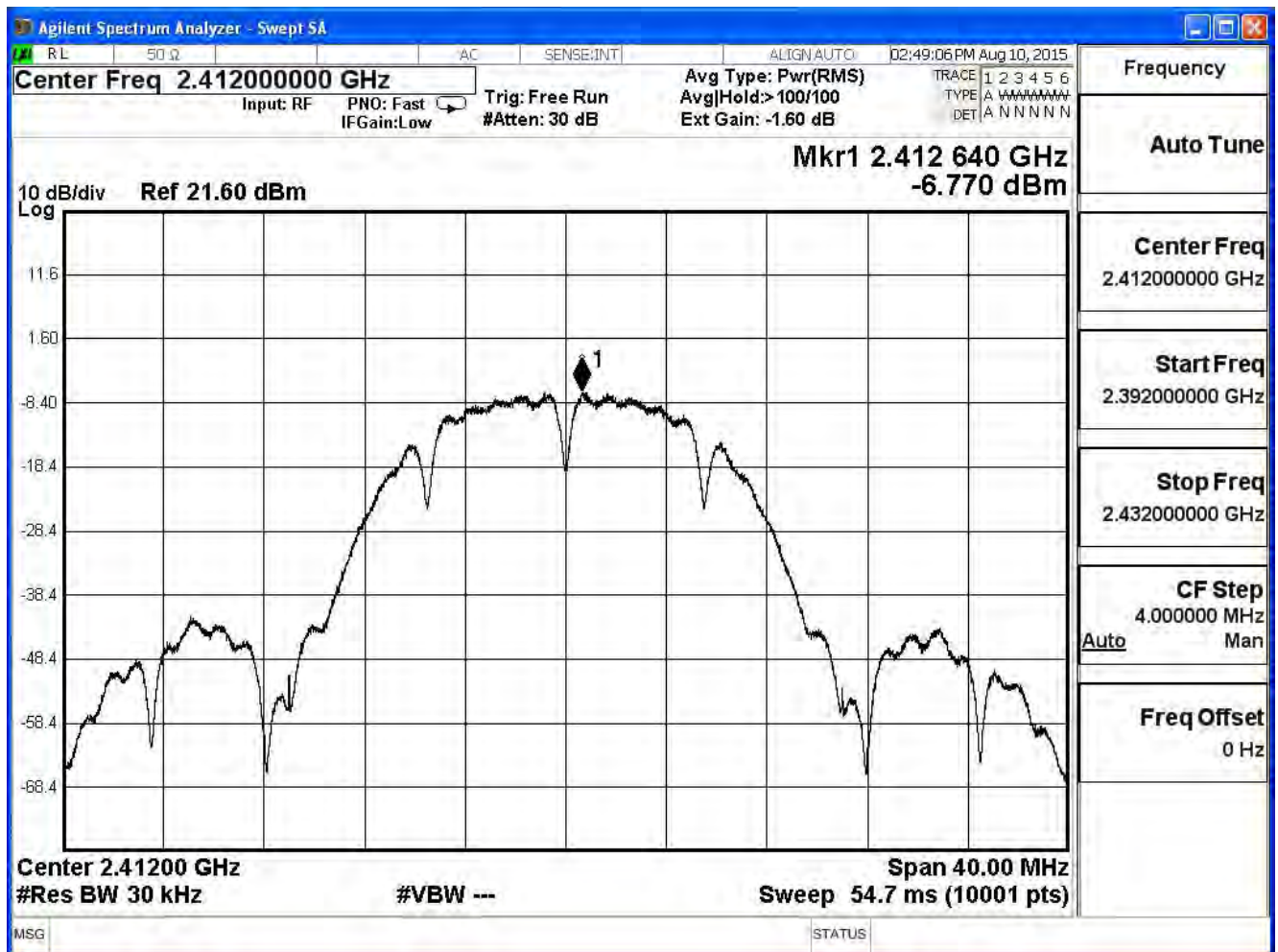

Channel 6 (2437MHz)

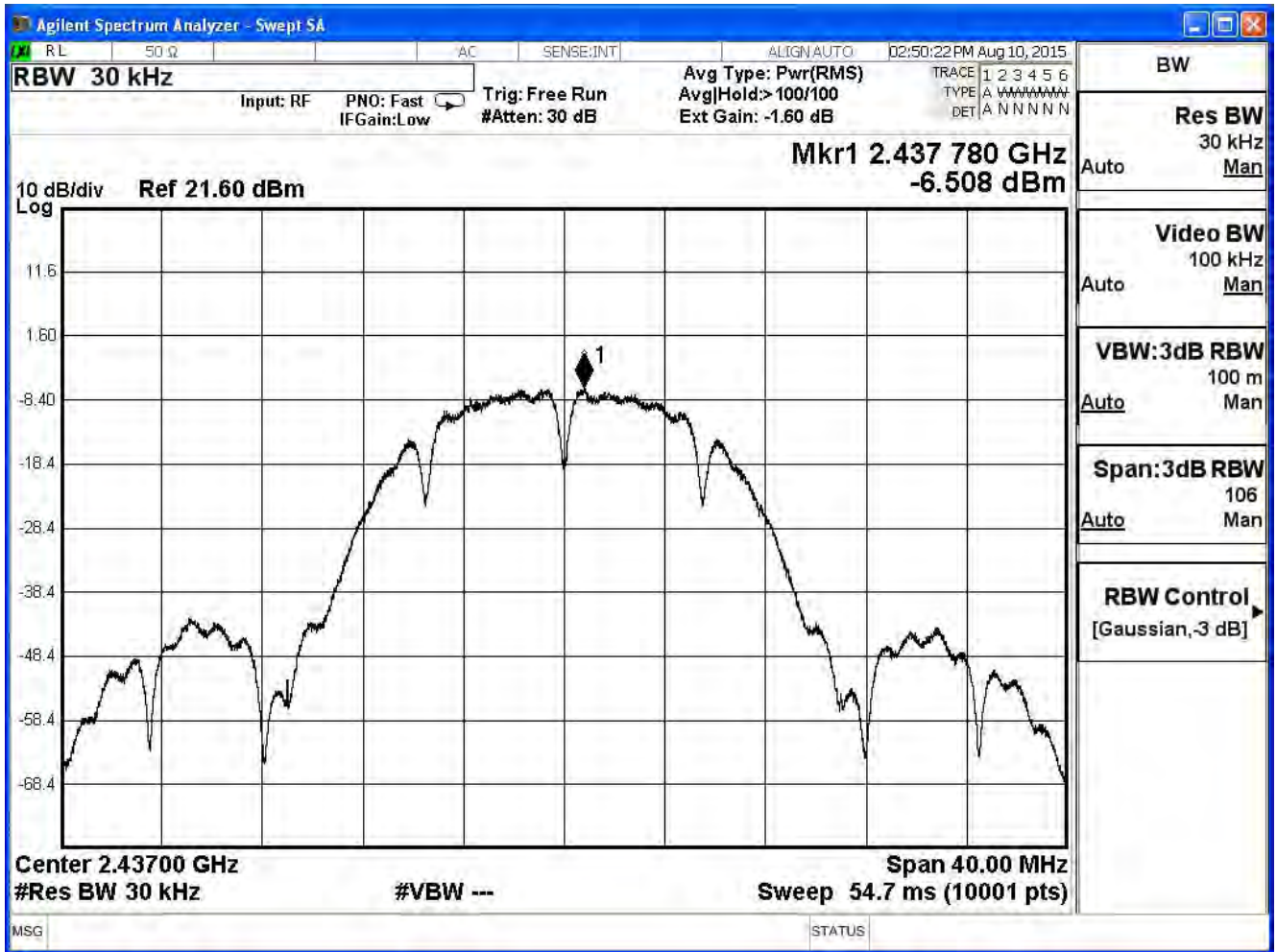

Channel 11 (2462MHz)

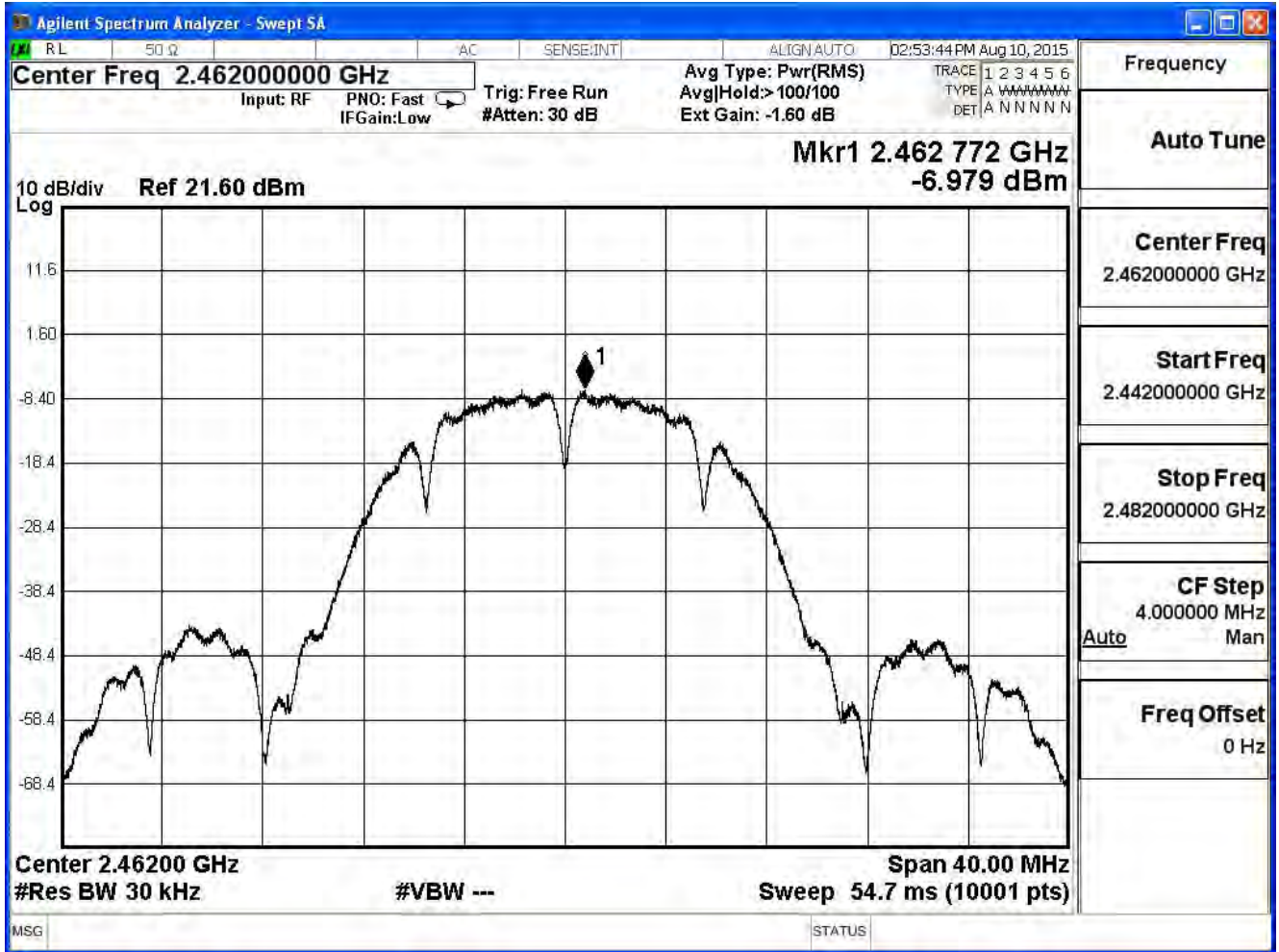

Product	ASUS SRT-AC1900 Wireless Smart Router		
Test Item	Power Density		
Test Mode	Mode 1: Tx- AUX Antenna (AD891M21)		
Date of Test	2015/08/10	Test Site	SR7

IEEE 802.11g (ANT 0)				
Channel No.	Frequency (MHz)	Measurement (dBm)	Limit (dBm)	Result
1	2412	-11.104	≤ 8	Pass
6	2437	-7.819	≤ 8	Pass
11	2462	-10.630	≤ 8	Pass

Channel 1 (2412MHz)

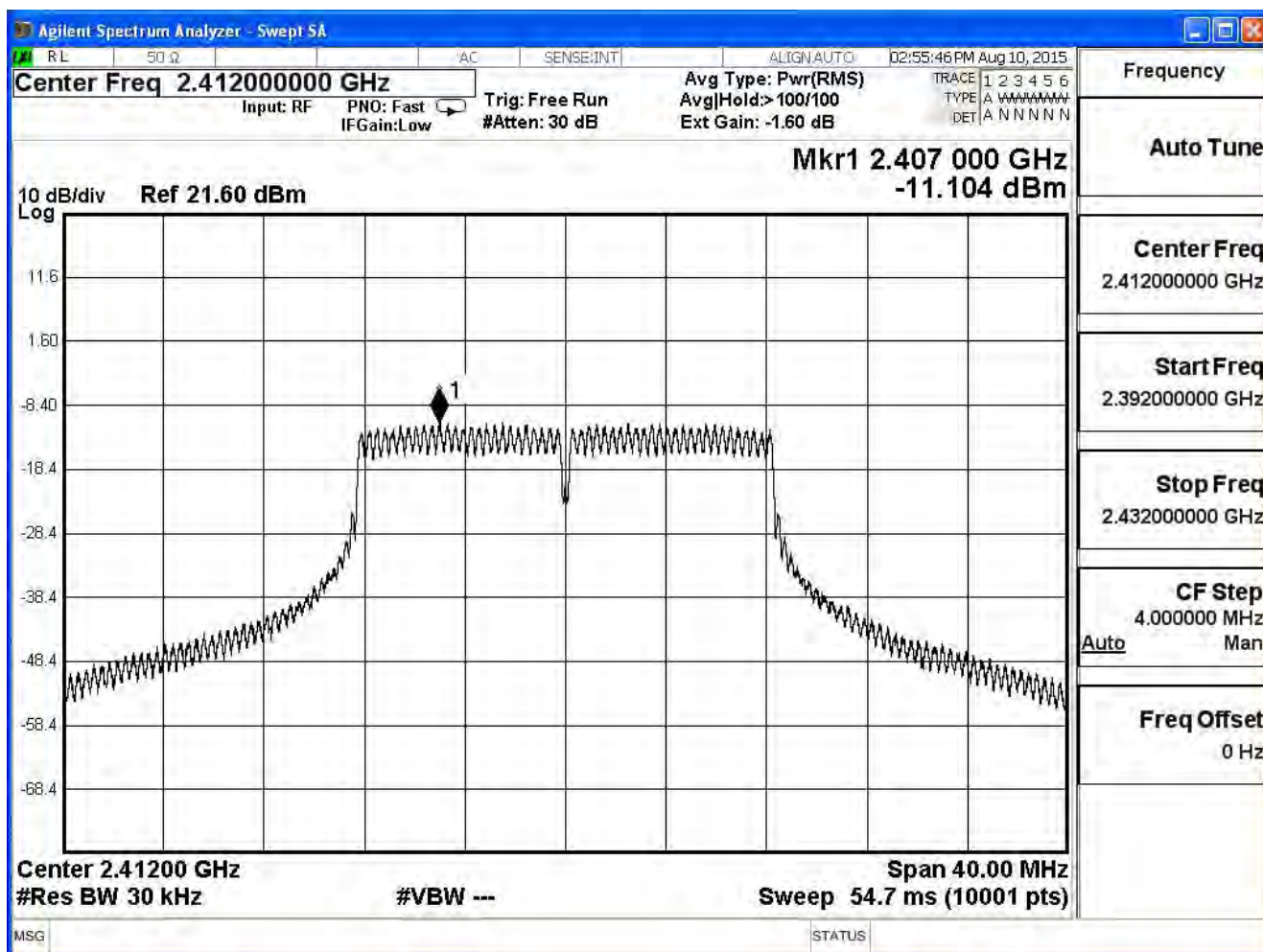

Channel 6 (2437MHz)

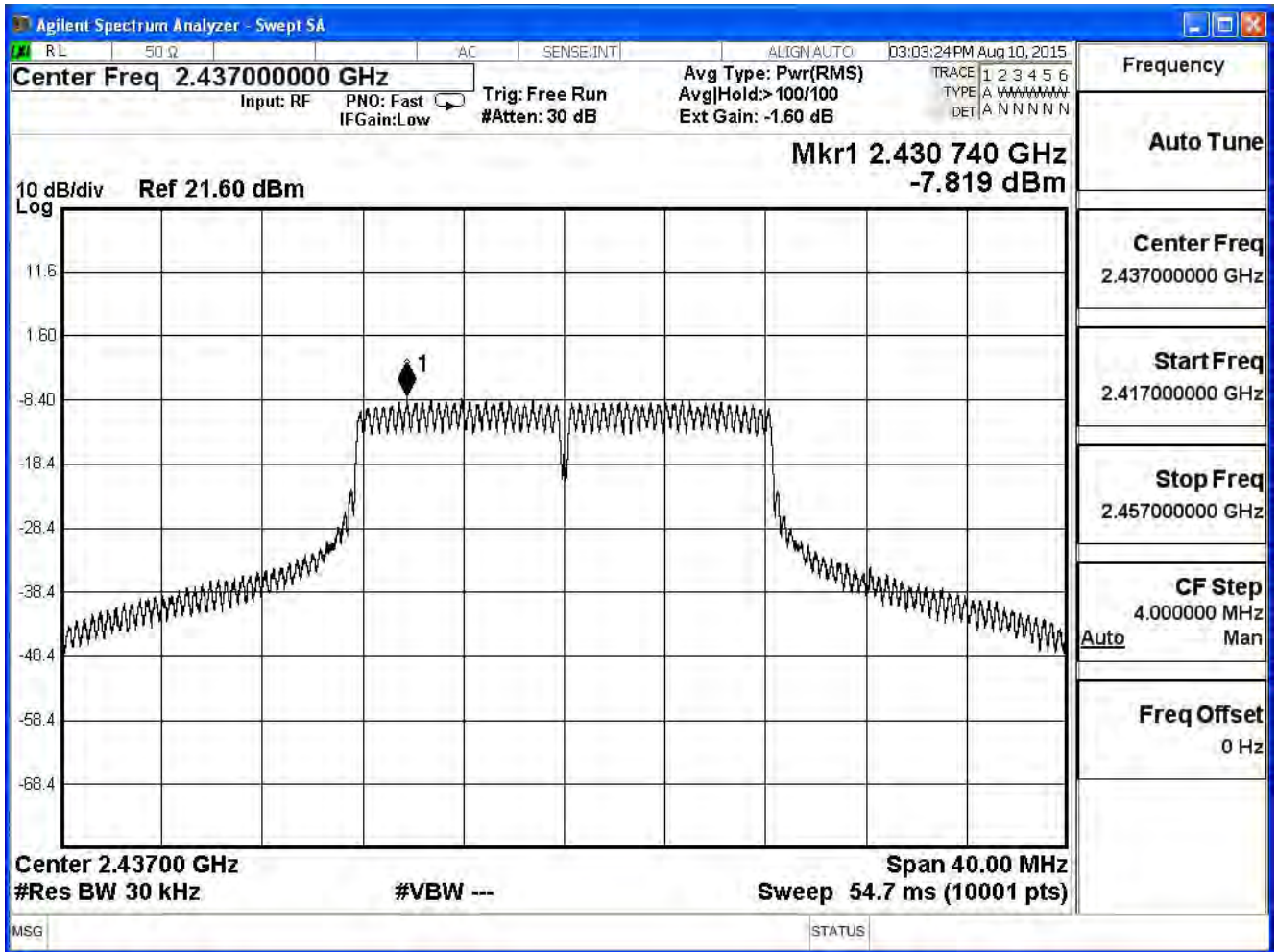

Channel 11 (2462MHz)

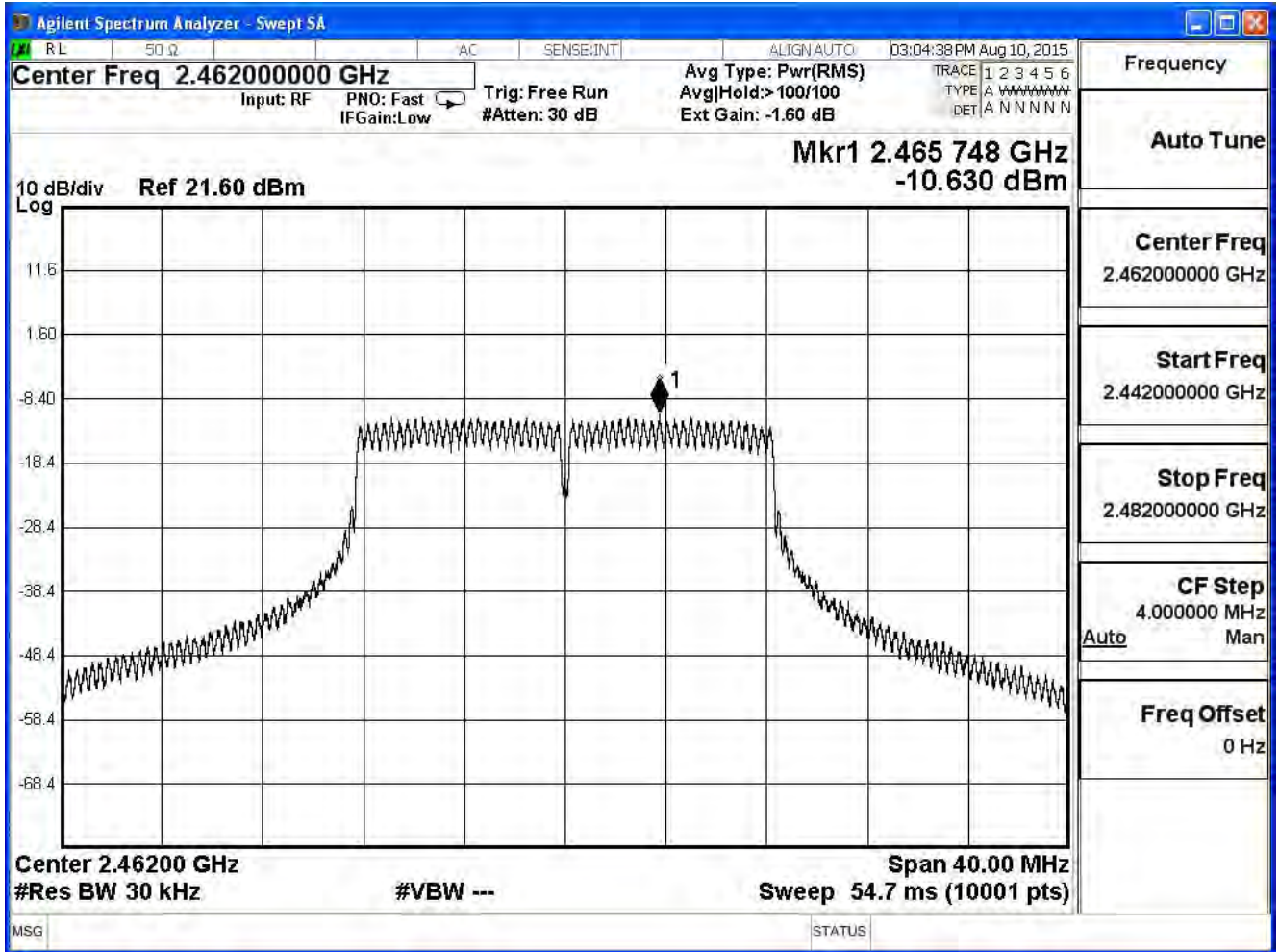

Product	ASUS SRT-AC1900 Wireless Smart Router		
Test Item	Power Density		
Test Mode	Mode 1: Tx- AUX Antenna (AD891M21)		
Date of Test	2015/08/10	Test Site	SR7

IEEE 802.11n (20MHz) (ANT 0)				
Channel No.	Frequency (MHz)	Measure Level (dBm)	Limit (dBm)	Result
1	2412	-12.545	≤ 8	Pass
6	2437	-8.608	≤ 8	Pass
11	2462	-12.171	≤ 8	Pass

Channel 1 (2412MHz)

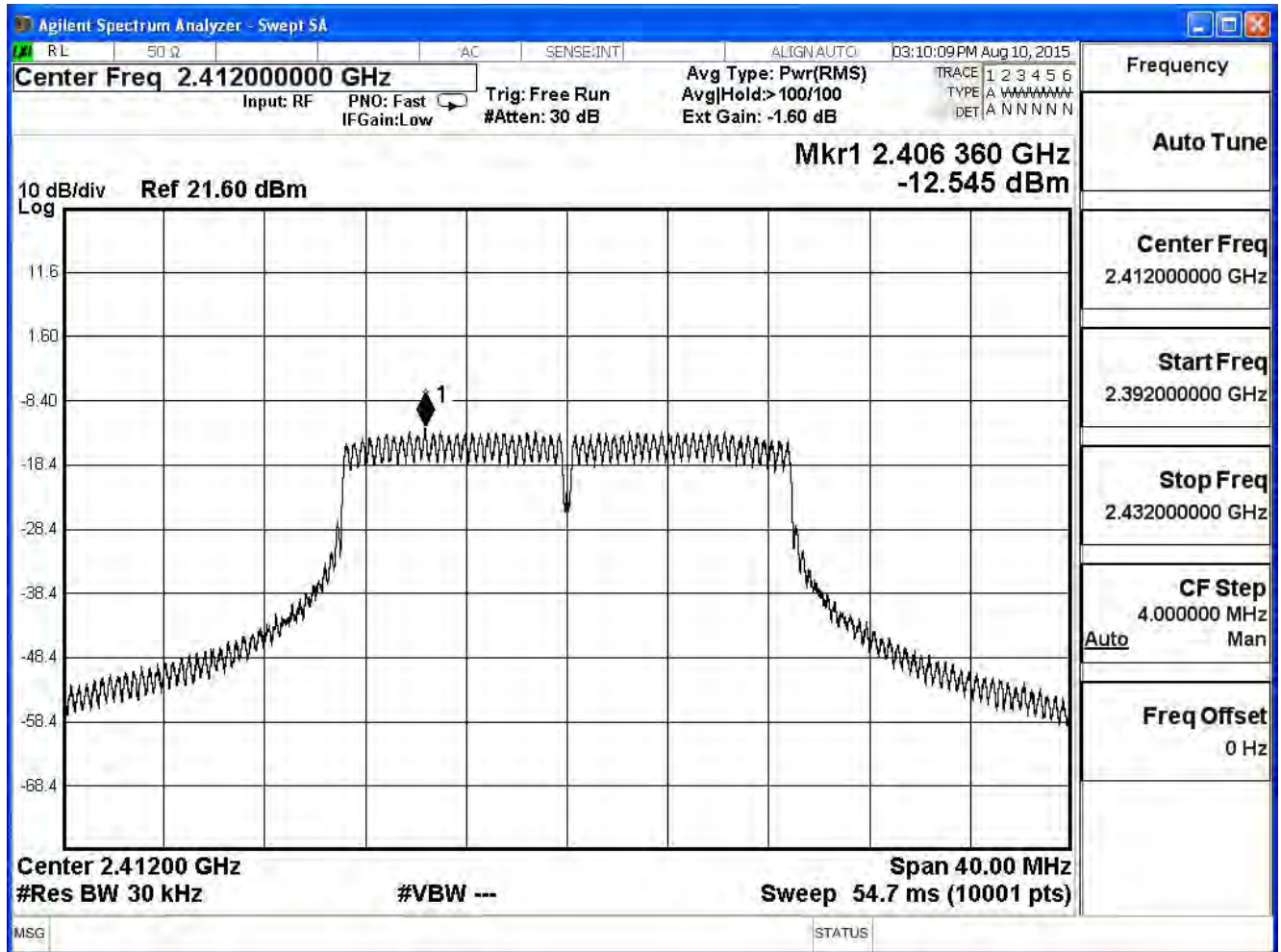

Channel 6 (2437MHz)

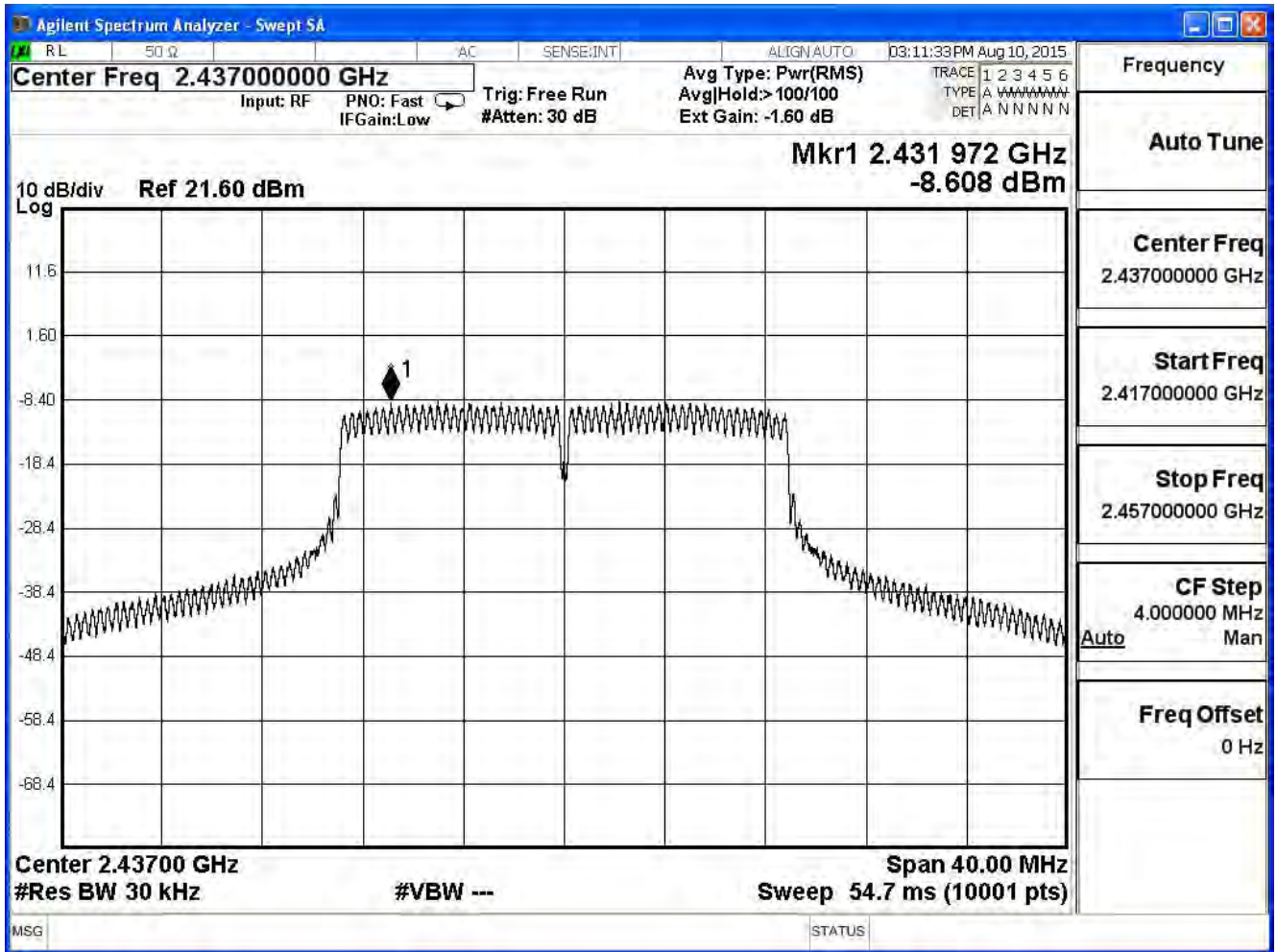

Channel 11 (2462MHz)

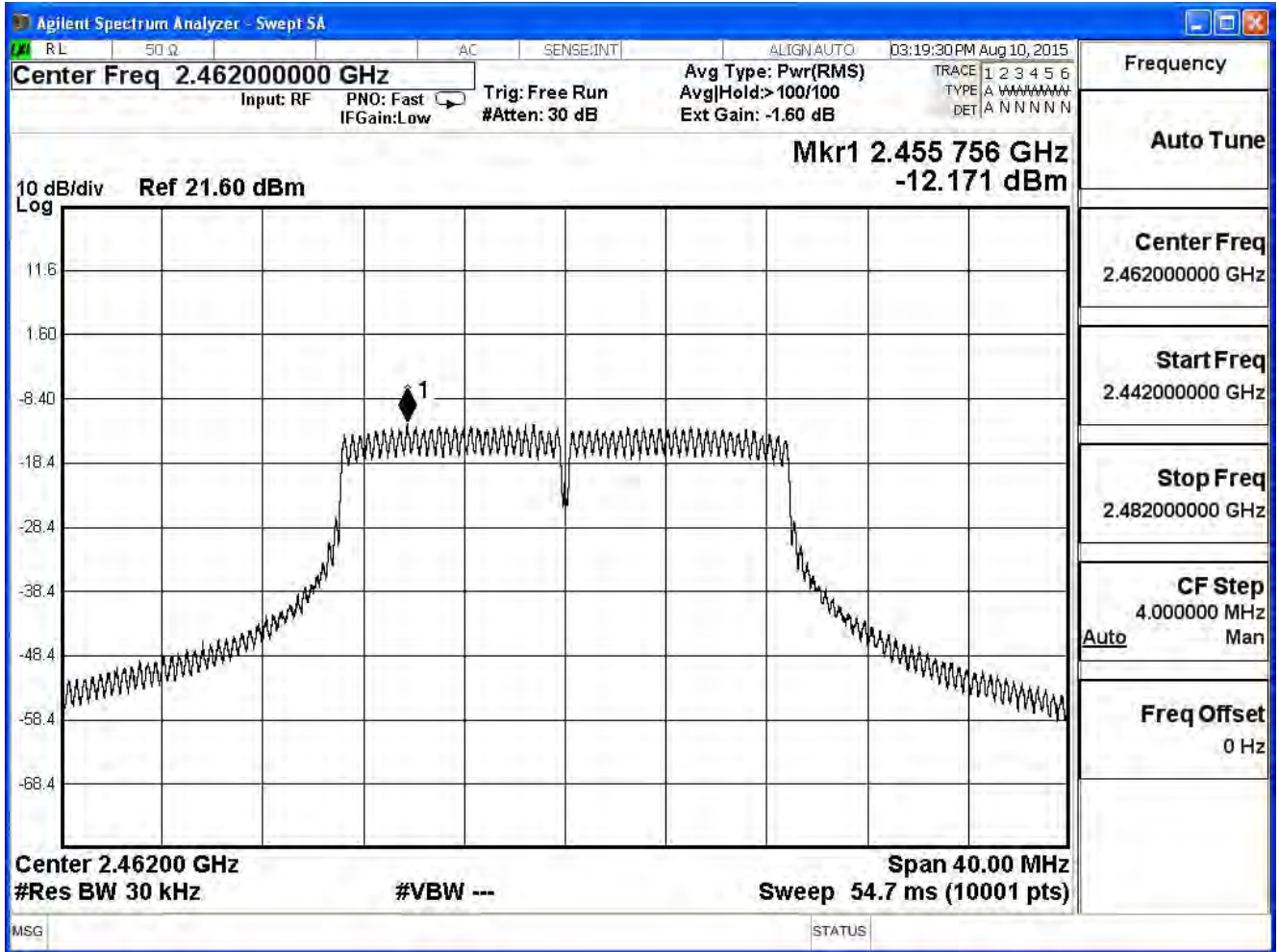

Product	ASUS SRT-AC1900 Wireless Smart Router		
Test Item	Power Density		
Test Mode	Mode 1: Tx- AUX Antenna (AD891M21)		
Date of Test	2015/08/10	Test Site	SR7

IEEE 802.11n (40MHz) (ANT 0)				
Channel No.	Frequency (MHz)	Measure Level (dBm)	Limit (dBm)	Result
3	2422	-18.520	≤ 8	Pass
6	2437	-15.271	≤ 8	Pass
9	2452	-18.625	≤ 8	Pass

Channel 3 (2422MHz)

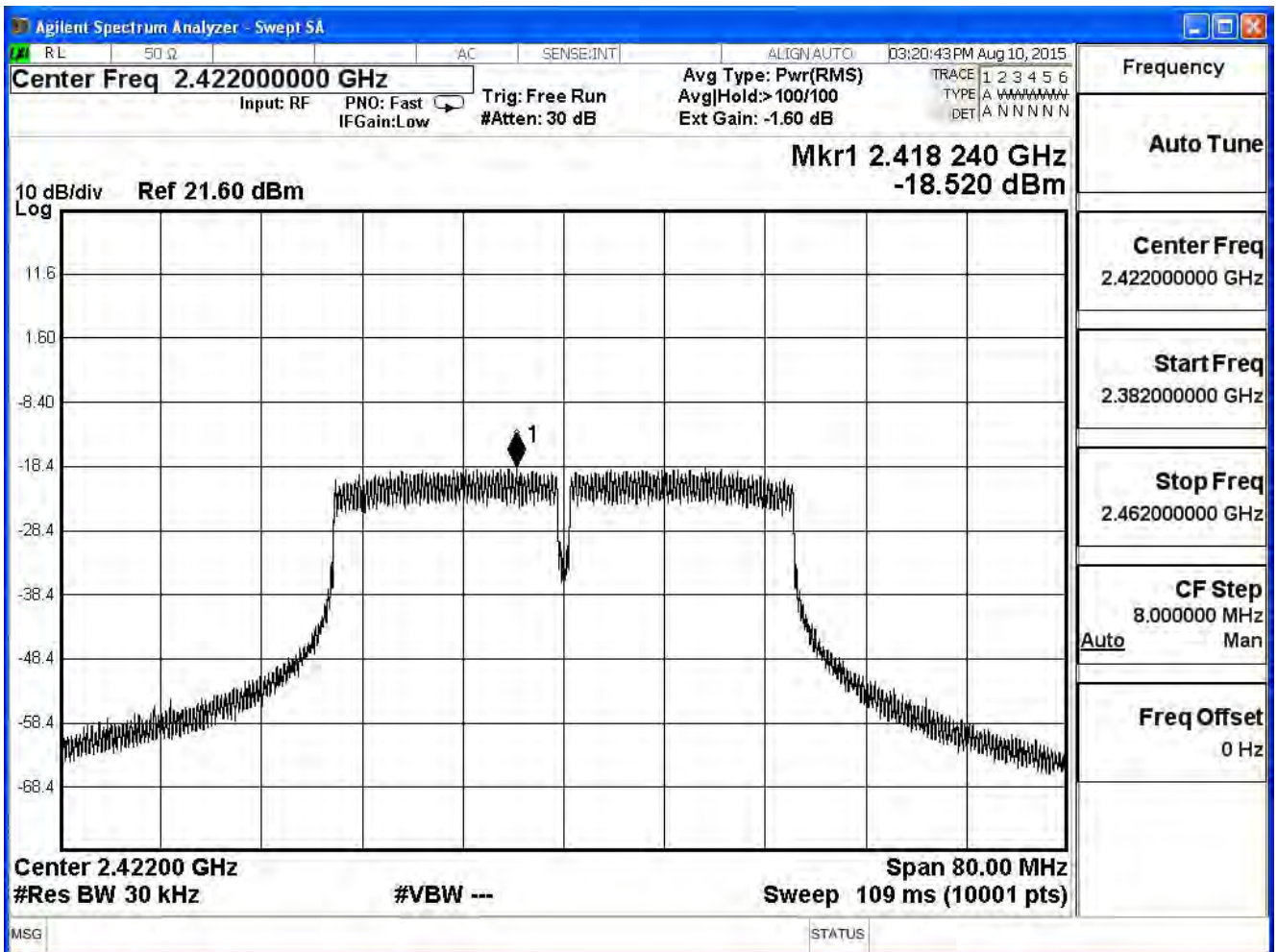

Channel 6 (2437MHz)

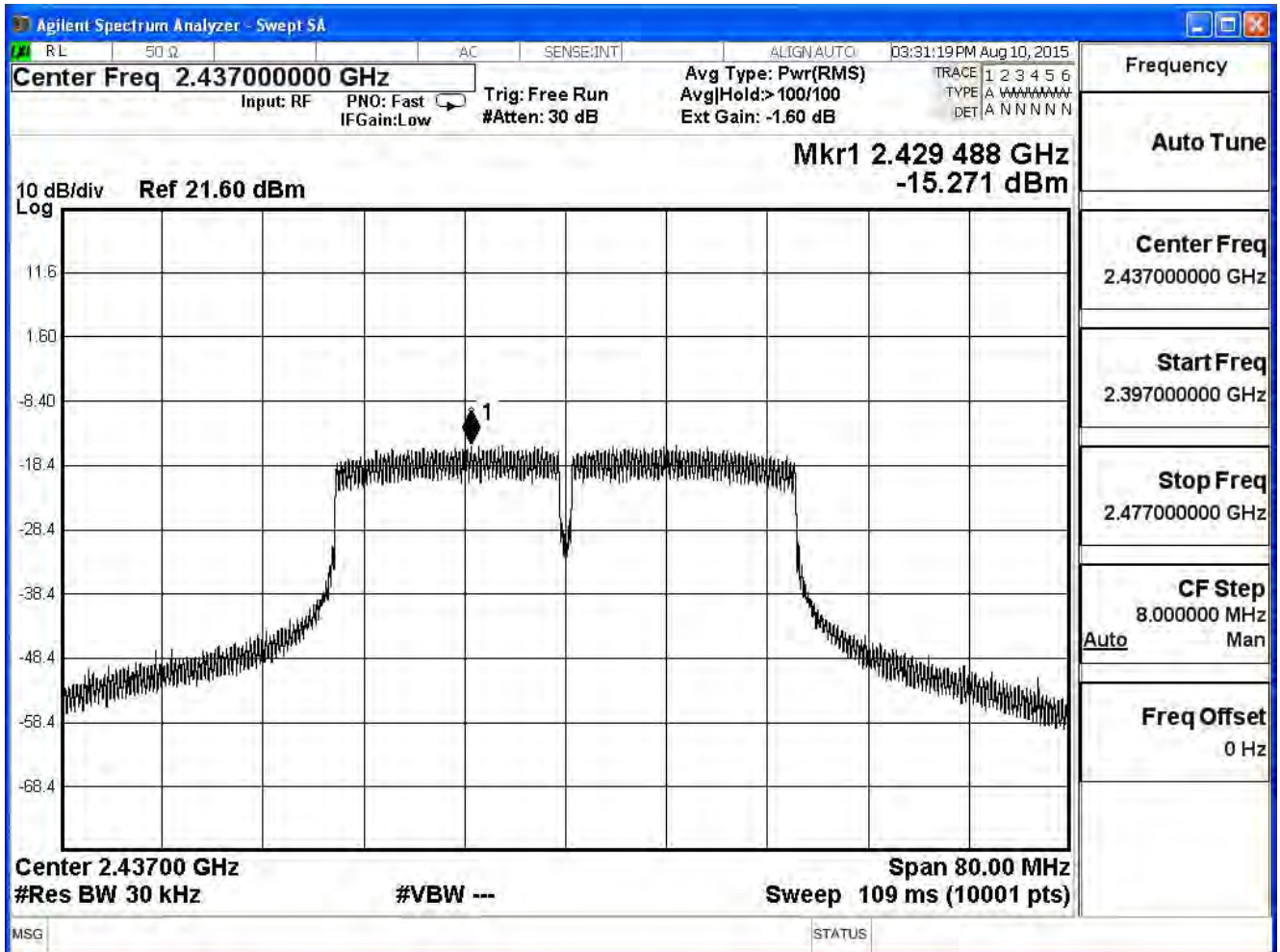

Channel 9 (2452MHz)

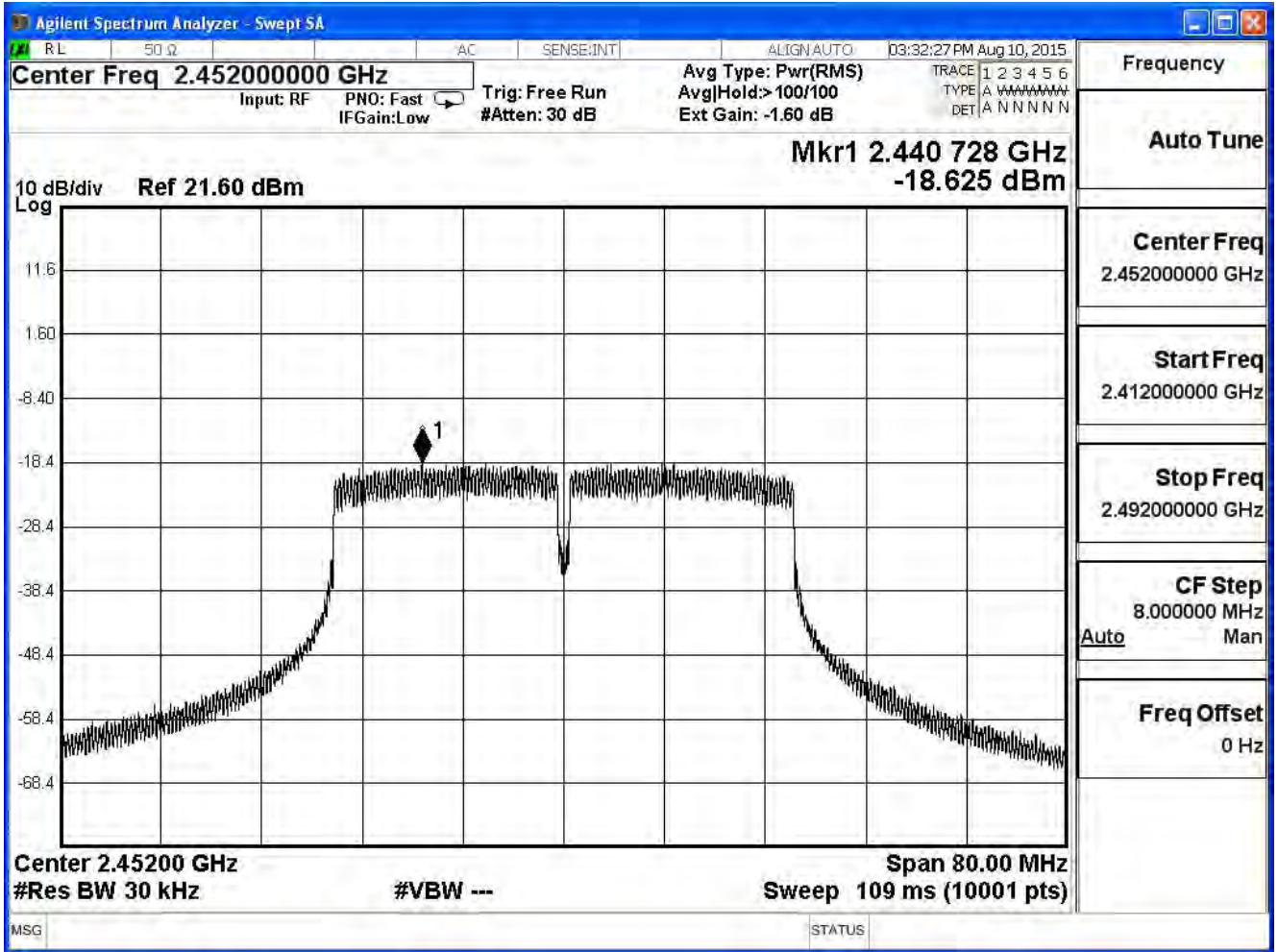

Attachment 1

➤ **ALL Channel List**

IEEE 802.11b			
Channel No.	Frequency (MHz)	Measure Level (dBm)	Limit (dBm)
1	2412	16.11	≤ 30
2	2417	16.13	≤ 30
3	2422	16.43	≤ 30
4	2427	16.24	≤ 30
5	2432	16.22	≤ 30
6	2437	16.20	≤ 30
7	2442	16.19	≤ 30
8	2447	16.43	≤ 30
9	2452	16.16	≤ 30
10	2457	16.29	≤ 30
11	2462	16.59	≤ 30

IEEE 802.11g			
Channel No.	Frequency (MHz)	Measure Level (dBm)	Limit (dBm)
1	2412	13.49	≤ 30
2	2417	16.28	≤ 30
3	2422	16.37	≤ 30
4	2427	16.14	≤ 30
5	2432	16.39	≤ 30
6	2437	16.28	≤ 30
7	2442	16.47	≤ 30
8	2447	16.37	≤ 30
9	2452	16.29	≤ 30
10	2457	16.18	≤ 30
11	2462	13.38	≤ 30

IEEE 802.11n20			
Channel No.	Frequency (MHz)	Measure Level (dBm)	Limit (dBm)
1	2412	11.85	≤ 30
2	2417	16.27	≤ 30
3	2422	16.41	≤ 30
4	2427	16.23	≤ 30
5	2432	16.11	≤ 30
6	2437	16.17	≤ 30
7	2442	16.27	≤ 30
8	2447	16.18	≤ 30
9	2452	16.43	≤ 30
10	2457	16.25	≤ 30
11	2462	12.28	≤ 30

IEEE 802.11n40			
Channel No.	Frequency (MHz)	Measure Level (dBm)	Limit (dBm)
3	2422	8.80	≤ 30
4	2427	12.17	≤ 30
5	2432	12.33	≤ 30
6	2437	12.26	≤ 30
7	2442	12.29	≤ 30
8	2447	12.42	≤ 30
9	2452	9.04	≤ 30