



RADIO TEST REPORT

FCC ID : MSQ-RTAXJG00
Equipment : AX5400 Dual Band WiFi Router
Brand Name : ASUS
Model Name : ZenWiFi XD6/ASUS ZenWiFi
XD6/RT-AX5400/XD6/XD6S/ZenWiFi XD6S/ASUS ZenWiFi XD6S
Applicant : ASUSTeK COMPUTER INC.
1F., No. 15, Lide Rd., Beitou Dist., Taipei City 112, Taiwan
Manufacturer (1) : Datamax Electronics (DongGuan) Co., Ltd.
Niu Shan Foreign Economic Industrial Park, Dong Cheng
District, Dong Guan City, Guang Dong, China
Manufacturer (2) : Lukisen Electronic Corp.
3F.,No.236,Boai St., Shulin Dist.,New Taipei City 23845, Taiwan
Manufacturer (3) : Lih Rong Electronic Enterprise Co.,Ltd.
No. 486, Sec. 1, Wanshou Road, Guishan District, Taoyuan City,
Taiwan
Standard : 47 CFR FCC Part 15.247

The product was received on Oct. 06, 2021, and testing was started from Oct. 06, 2021 and completed on Nov. 05, 2021. We, Sporton International Inc. Hsinchu Laboratory, would like to declare that the tested sample has been evaluated in accordance with the procedures given in ANSI C63.10-2013 and shown compliance with the applicable technical standards.

The test results in this variant report apply exclusively to the tested model / sample. Without written approval of Sporton International Inc. Hsinchu Laboratory, the test report shall not be reproduced except in full.

Approved by: Sam Chen

Sporton International Inc. Hsinchu Laboratory

No.8, Ln. 724, Bo'ai St., Zhubei City, Hsinchu County 302010, Taiwan (R.O.C.)



Table of Contents

History of this test report.....3

Summary of Test Result.....4

1 General Description5

1.1 Information.....5

1.2 Applicable Standards10

1.3 Testing Location Information10

1.4 Measurement Uncertainty10

2 Test Configuration of EUT11

2.1 Test Channel Mode11

2.2 The Worst Case Measurement Configuration.....11

2.3 EUT Operation during Test12

2.4 Accessories12

2.5 Support Equipment.....12

2.6 Test Setup Diagram13

3 Transmitter Test Result16

3.1 AC Power-line Conducted Emissions16

3.2 Emissions in Restricted Frequency Bands.....18

4 Test Equipment and Calibration Data22

Appendix A. Test Results of AC Power-line Conducted Emissions

Appendix B. Test Results of Emissions in Restricted Frequency Bands

Appendix C. Test Photos

Photographs of EUT v01



Summary of Test Result

Report Clause	Ref Std. Clause	Test Items	Result (PASS/FAIL)	Remark
1.1.2	15.203	Antenna Requirement	PASS	-
3.1	15.207	AC Power-line Conducted Emissions	PASS	-
3.2	15.247(d)	Emissions in Restricted Frequency Bands	PASS	-

Declaration of Conformity:

The test results with all measurement uncertainty excluded are presented in accordance with the regulation limits or requirements declared by manufacturers.

Comments and Explanations:

The declared of product specification for EUT presented in the report are provided by the manufacturer, and the manufacturer takes all the responsibilities for the accuracy of product specification.

Reviewed by: **Sam Chen**

Report Producer: **Jessie Wei**



1 General Description

1.1 Information

1.1.1 RF General Information

Frequency Range (MHz)	IEEE Std. 802.11	Ch. Frequency (MHz)	Channel Number
2400-2483.5	b, g, n (HT20), VHT20, ax (HEW20)	2412-2462	1-11 [11]
2400-2483.5	n (HT40), VHT40, ax (HEW40)	2422-2452	3-9 [7]

Band	Mode	BWch (MHz)	Nant
2.4-2.4835GHz	11b	20	2
2.4-2.4835GHz	11g	20	2
2.4-2.4835GHz	802.11n HT20	20	2
2.4-2.4835GHz	802.11n HT20-BF	20	2
2.4-2.4835GHz	VHT20	20	2
2.4-2.4835GHz	VHT20-BF	20	2
2.4-2.4835GHz	802.11ax HEW20	20	2
2.4-2.4835GHz	802.11ax HEW20-BF	20	2
2.4-2.4835GHz	802.11n HT40	40	2
2.4-2.4835GHz	802.11n HT40-BF	40	2
2.4-2.4835GHz	VHT40	40	2
2.4-2.4835GHz	VHT40-BF	40	2
2.4-2.4835GHz	802.11ax HEW40	40	2
2.4-2.4835GHz	802.11ax HEW40-BF	40	2

Note:

- ♦ 11b mode uses a combination of DSSS-DBPSK, DQPSK, CCK modulation.
- ♦ 11g, HT20 and HT40 use a combination of OFDM-BPSK, QPSK, 16QAM, 64QAM modulation.
- ♦ VHT20, VHT40 use a combination of OFDM-BPSK, QPSK, 16QAM, 64QAM, 256QAM, 1024QAM modulation.
- ♦ HEW20, HEW40 use a combination of OFDMA-BPSK, QPSK, 16QAM, 64QAM, 256QAM, 1024QAM modulation.
- ♦ BWch is the nominal channel bandwidth.



1.1.2 Antenna Information

Set	Ant.	2.4GHz Port	5GHz Port	Bluetooth	Brand	Model Name	Antenna Type	Connector	Gain (dBi)
1	1	2	-	-	M.gear	C660-510545-A (SRF20201842)	PCB Antenna	I-PEX	Note 1
	2	-	2	-	M.gear	C660-510545-A (SRF20201842)	Dipole Antenna	I-PEX	
	3	-	4	-	M.gear	C660-510545-A (SRF20201842)	Dipole Antenna	I-PEX	
	4	1	-	-	M.gear	C660-510545-A (SRF20201842)	PCB Antenna	I-PEX	
	5	-	3	-	M.gear	C660-510545-A (SRF20201842)	Dipole Antenna	I-PEX	
	6	-	1	-	M.gear	C660-510545-A (SRF20201842)	Dipole Antenna	I-PEX	
2	1	2	-	-	PSA	RFPCA351314 IMAB702	PCB Antenna	I-PEX	
	2	-	2	-	PSA	RFPCA351314 IMAB702	Dipole Antenna	I-PEX	
	3	-	4	-	PSA	RFPCA351314 MAB702	Dipole Antenna	I-PEX	
	4	1	-	-	PSA	RFPCA351314 MAB702	PCB Antenna	I-PEX	
	5	-	3	-	PSA	RFPCA351314 MAB702	Dipole Antenna	I-PEX	
	6	-	1	-	PSA	RFPCA351314 MAB702	Dipole Antenna	I-PEX	
3	1	-	-	1	YAGEO	ANT3216A063R 2400A	Chip Antenna	N/A	



Note 1:

Set	Ant.	Gain (dBi)															Bluet ooth
		2.4GHz			5GHz Band 1			5GHz Band 2			5GHz Band 3			5GHz Band 4			
		CDD	DG (Nss1)	DG (Nss2)	CDD	DG (Nss1)	DG (Nss2)	CDD	DG (Nss1)	DG (Nss2)	CDD	DG (Nss1)	DG (Nss2)	CDD	DG (Nss1)	DG (Nss2)	
1	1~6	1.21	4.16	-	1.21	6.96	4.14	1.39	7.19	4.37	0.99	6.75	3.93	1.24	7.00	4.25	-
2	1~6	1.21	4.16	-	1.21	6.96	4.14	1.39	7.19	4.37	0.99	6.75	3.93	1.24	7.00	4.25	-
3	1	-	-	-	-	-	-	-	-	-	-	-	-	-	-	-	1.69

Note 2: The above information was declared by manufacturer.

Note 3: The EUT has two set of antenna and each set has six antennas for WLAN. There are the same type, so only the set 1 antenna was selected to test and record in this report.

For 2.4GHz function:

IEEE 802.11b/g/n/VHT/ax (2TX/2RX):

Port 1 and Port 2 can be used as transmitting/receiving antenna.

Port 1 and Port 2 could transmit/receive simultaneously.

For 5GHz function:

IEEE 802.11a/n/ac/ax (4TX/4RX):

Port 1, Port 2, Port 3 and Port 4 can be used as transmitting/receiving antenna.

Port 1, Port 2, Port 3 and Port 4 could transmit/receive simultaneously.

For Bluetooth Function (1TX/1RX):

Only Port 1 can be used as transmitting/receiving antenna.



1.1.3 Mode Test Duty Cycle

Mode	DC	DCF(dB)	T(s)	VBW(Hz) ≥ 1/T
802.11b	0.995	0.02	n/a (DC>=0.98)	n/a (DC>=0.98)

Note:

- ◆ DC is Duty Cycle.
- ◆ DCF is Duty Cycle Factor.

1.1.4 EUT Operational Condition

EUT Power Type	From Power Adapter			
Beamforming Function	<input checked="" type="checkbox"/> With beamforming	<input type="checkbox"/> Without beamforming		
	The product has beamforming function for n/VHT/ax in 2.4GHz and n/ac/ax in 5GHz.			
Function	<input checked="" type="checkbox"/> Point-to-multipoint	<input type="checkbox"/> Point-to-point		
Test Software Version	Mtool_v3.2.1.1			

Note: The above information was declared by manufacturer.

1.1.5 Table for EUT supports functions

Function	Support Type
AP Router	Master
Bridge	Slave without radar detection
Repeater	Master
Mesh	Master

Note: After evaluating, only AP Router was selected to test and record in the report.



1.1.6 Table for Multiple Listing

The model names in the following table are all refer to the identical product.

Model Name	Description
ZenWiFi XD6	All the models are identical, the different model names served as marketing strategy.
ASUS ZenWiFi XD6	
RT-AX5400	
XD6	
XD6S	
ZenWiFi XD6S	
ASUS ZenWiFi XD6S	

Note 1: From the above models, model: XD6 was selected to test all items, and model: XD6S has been selected to test AC Power-line Conducted Emissions and Emissions in Restricted Frequency Bands only.

Note 2: The above information was declared by manufacturer.

1.1.7 Table for SKU Information

EUT	2.4GHz Chipset	Memory Size	LAN Ethernet port
SKU 1	BCM6750	RAM 512MB; Flash 256MB	RJ-45 for Gigabits / BaseT for LAN x 3
SKU 2	BCM6752	RAM 512MB; Flash 128MB	RJ-45 for Gigabits / BaseT for LAN x 1

Note1: There is only SKU 2 tested and recorded in this report.

Note2: The above information was declared by manufacturer.

1.1.8 Table for Permissive Change

This product is an extension of original one reported under Sporton project number: FR0D0706AA

Below is the table for the change of the product with respect to the original one.

Modifications	Performance Checking
1. Adding a new model name: XD6S.	After evaluating, it doesn't affect the test results.
2. Adding SKU 2, the difference from SKU 1 is only the 2.4G RF Chipset/Flash/quantity of LAN port, other parts and layout are the same.	1. AC Power-line Conducted Emissions 2. Emissions in Restricted Frequency Bands (For above 1GHz: After evaluating, the worst case is found at 802.11b 2437MHz, and retested this channel only.)



1.2 Applicable Standards

According to the specifications of the manufacturer, the EUT must comply with the requirements of the following standards:

- ♦ 47 CFR FCC Part 15.247
- ♦ ANSI C63.10-2013

The following reference test guidance is not within the scope of accreditation of TAF.

- ♦ FCC KDB 558074 D01 v05r02
- ♦ FCC KDB 414788 D01 v01r01

1.3 Testing Location Information

Testing Location Information	
Test Lab. : Sporton International Inc. Hsinchu Laboratory	
Hsinchu (TAF: 3787)	ADD: No.8, Ln. 724, Bo'ai St., Zhubei City, Hsinchu County 302010, Taiwan (R.O.C.) TEL: 886-3-656-9065 FAX: 886-3-656-9085 Test site Designation No. TW3787 with FCC. Conformity Assessment Body Identifier (CABID) TW3787 with ISED.

Test Condition	Test Site No.	Test Engineer	Test Environment (°C / %)	Test Date
Radiated below 1GHz	03CH05-CB	Stim Sung	24.3~25.4 / 55~58	Oct. 06, 2021~ Oct. 27, 2021
Radiated above 1GHz	03CH06-CB	Stim Sung	23.9~24.8 / 55~58	
AC Conduction	CO01-CB	Peter Wu	22~23 / 61~62	Nov. 05, 2021

1.4 Measurement Uncertainty

ISO/IEC 17025 requires that an estimate of the measurement uncertainties associated with the emissions test results be included in the report. The measurement uncertainties given below are based on a 95% confidence level (based on a coverage factor (k=2))

Test Items	Uncertainty	Remark
Conducted Emission (150kHz ~ 30MHz)	2.0 dB	Confidence levels of 95%
Radiated Emission (9kHz ~ 30MHz)	4.2 dB	Confidence levels of 95%
Radiated Emission (30MHz ~ 1,000MHz)	5.5 dB	Confidence levels of 95%
Radiated Emission (1GHz ~ 18GHz)	4.7 dB	Confidence levels of 95%
Radiated Emission (18GHz ~ 40GHz)	4.2 dB	Confidence levels of 95%



2 Test Configuration of EUT

2.1 Test Channel Mode

Mode	Power Setting
802.11b_Nss1,(1Mbps)_2TX	-
2437MHz	108

2.2 The Worst Case Measurement Configuration

The Worst Case Mode for Following Conformance Tests	
Tests Item	AC power-line conducted emissions
Condition	AC power-line conducted measurement for line and neutral Test Voltage: 120Vac / 60Hz
Operating Mode	Normal Link
The EUT performed testing at power adapter 1 and power adapter 2. After evaluating, power adapter 1 has been evaluated to be the worst case, thus the measurement will follow same test configuration.	
1	AP router – EUT (SKU 2) + Adapter 1

The Worst Case Mode for Following Conformance Tests	
Tests Item	Emissions in Restricted Frequency Bands
Test Condition	Radiated measurement If EUT consist of multiple antenna assembly (multiple antenna are used in EUT regardless of spatial multiplexing MIMO configuration), the radiated test should be performed with highest antenna gain of each antenna type.
Operating Mode < 1GHz	CTX
1	EUT (SKU 2)_WLAN 2.4GHz + Adapter 1
2	EUT (SKU 2)_WLAN 2.4GHz + Adapter 2
Mode 1 has been evaluated to be the worst case among Mode 1~2, thus measurement for Mode 3~4 will follow this same test mode.	
3	EUT (SKU 2)_WLAN 5GHz + Adapter 1
4	EUT (SKU 2)_Bluetooth + Adapter 1
For operating mode 1 is the worst case and it was record in this test report.	
Operating Mode > 1GHz	CTX
1	EUT (SKU 2)

Note: The EUT can only be used at Y axis position.



2.3 EUT Operation during Test

For CTX Mode:

The EUT was programmed to be in continuously transmitting mode.

For Normal Link:

During the test, the EUT operation to normal function.

2.4 Accessories

Accessories			
Equipment Name	Brand Name	Model Name	Rating
Adapter 1	LEI	MU24D1120200-A1	INPUT: 100-240V ~ 50/60Hz, 0.7A OUTPUT: 12V, 2A
Adapter 2	DVE	DSA-24PFS-12 FUS 120200	INPUT: 100-240V ~ 50/60Hz, 0.8A OUTPUT: 12.0V, 2.0A, 24.0W
Others			
RJ-45 cable 1: Non-shielded, 2m			
Wall-mounted rack*1			

2.5 Support Equipment

For AC Conduction:

Support Equipment				
No.	Equipment	Brand Name	Model Name	FCC ID
A	LAN NB	DELL	E6430	N/A
B	2.4G NB	DELL	E6430	N/A
C	5G NB	DELL	E6430	N/A
D	WAN NB	DELL	E6430	N/A

For Radiated:

Support Equipment				
No.	Equipment	Brand Name	Model Name	FCC ID
A	Notebook	DELL	E4300	N/A

2.6 Test Setup Diagram

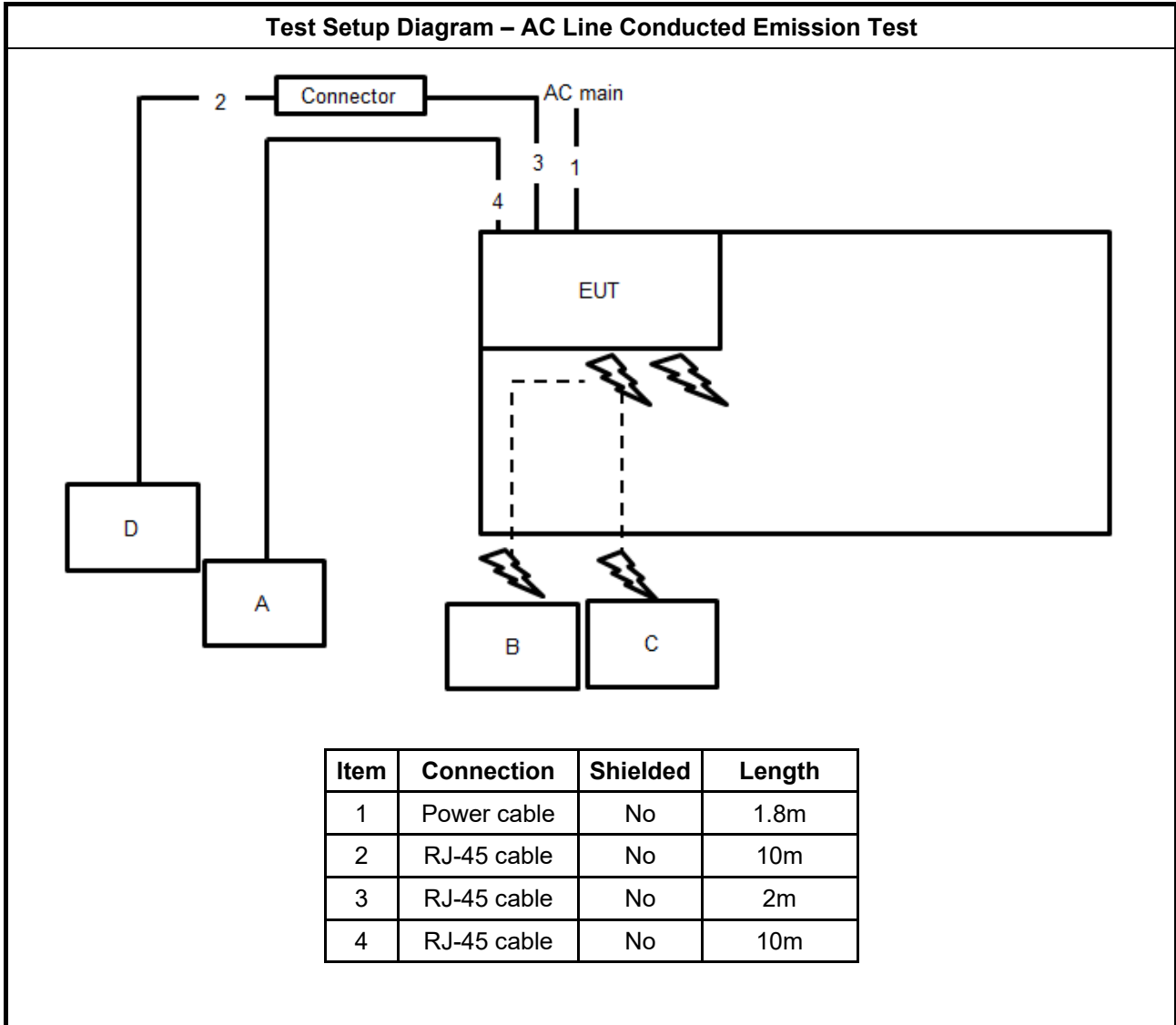

Test Setup Diagram - Radiated Test < 1GHz

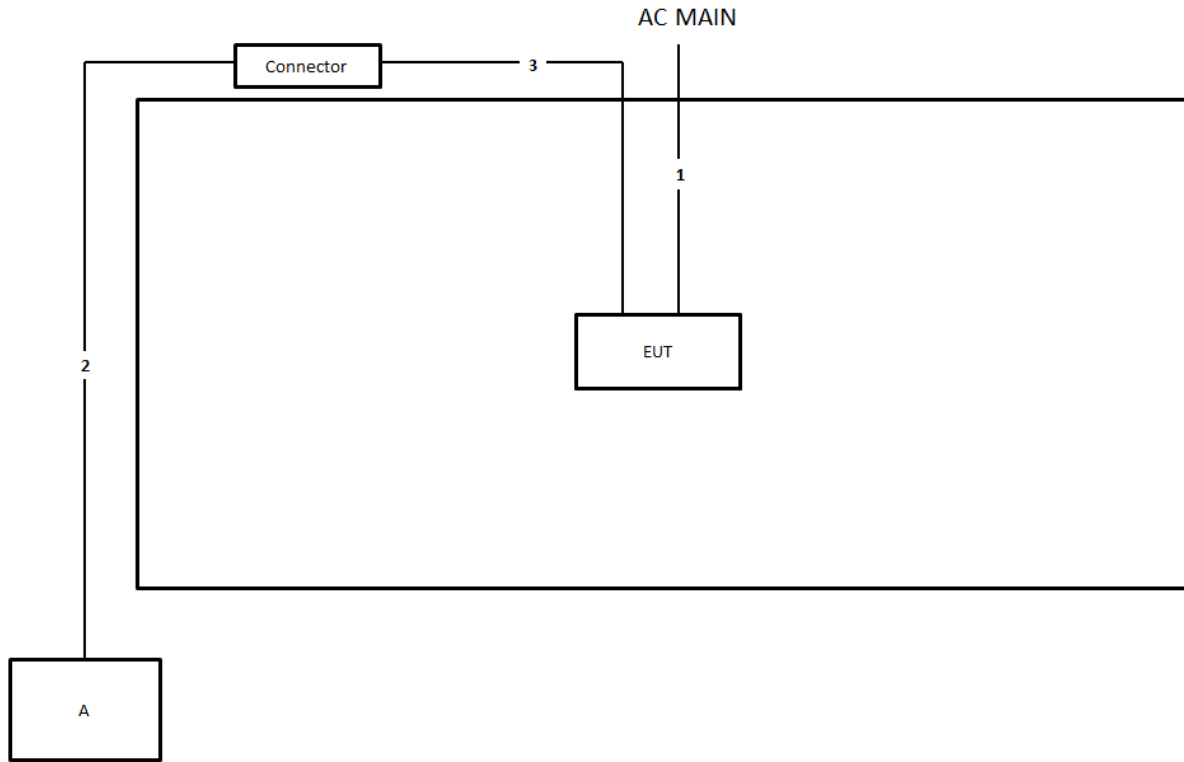

Item	Connection	Shielded	Length
1	Power cable	No	1.8m
2	RJ-45 cable	No	10m
3	RJ-45 cable	No	2m

Test Setup Diagram - Radiated Test > 1GHz

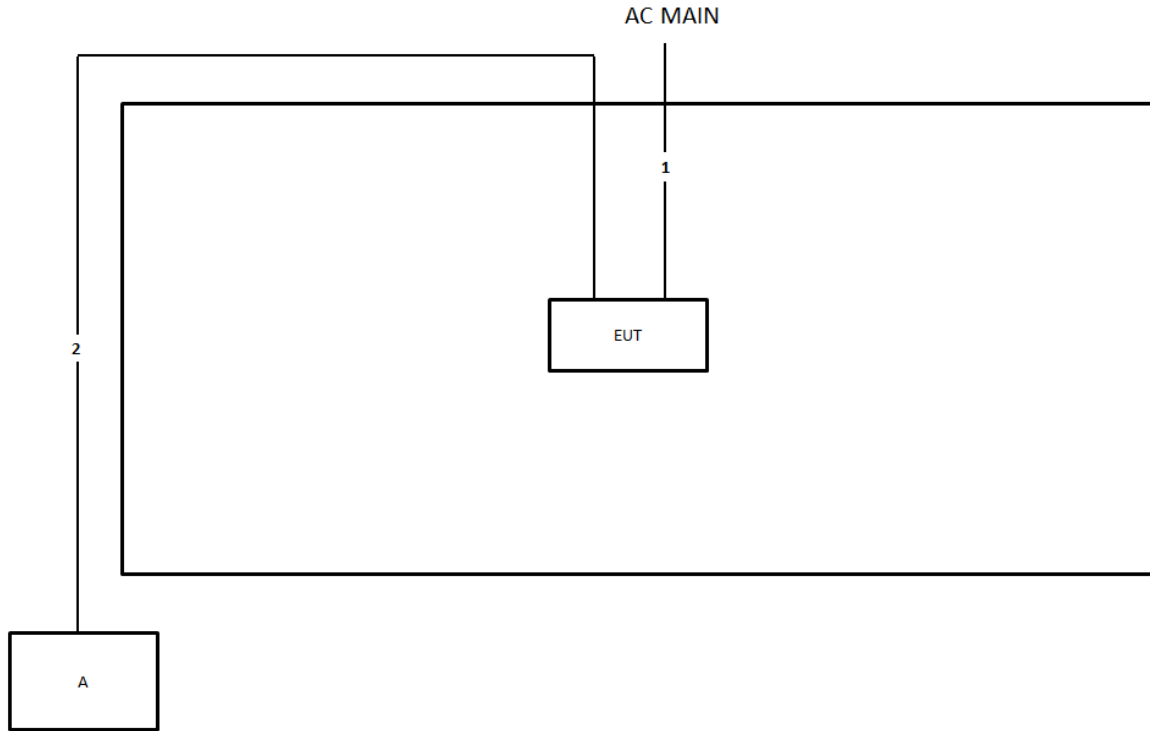

Item	Connection	Shielded	Length
1	Power cable	No	1.8m
2	RJ-45 cable	No	10m



3 Transmitter Test Result

3.1 AC Power-line Conducted Emissions

3.1.1 AC Power-line Conducted Emissions Limit

AC Power-line Conducted Emissions Limit		
Frequency Emission (MHz)	Quasi-Peak	Average
0.15-0.5	66 - 56 *	56 - 46 *
0.5-5	56	46
5-30	60	50

Note 1: * Decreases with the logarithm of the frequency.

3.1.2 Measuring Instruments

Refer a test equipment and calibration data table in this test report.

3.1.3 Test Procedures

Test Method
<input checked="" type="checkbox"/> Refer as ANSI C63.10-2013, clause 6.2 for AC power-line conducted emissions.

3.1.4 Test Setup

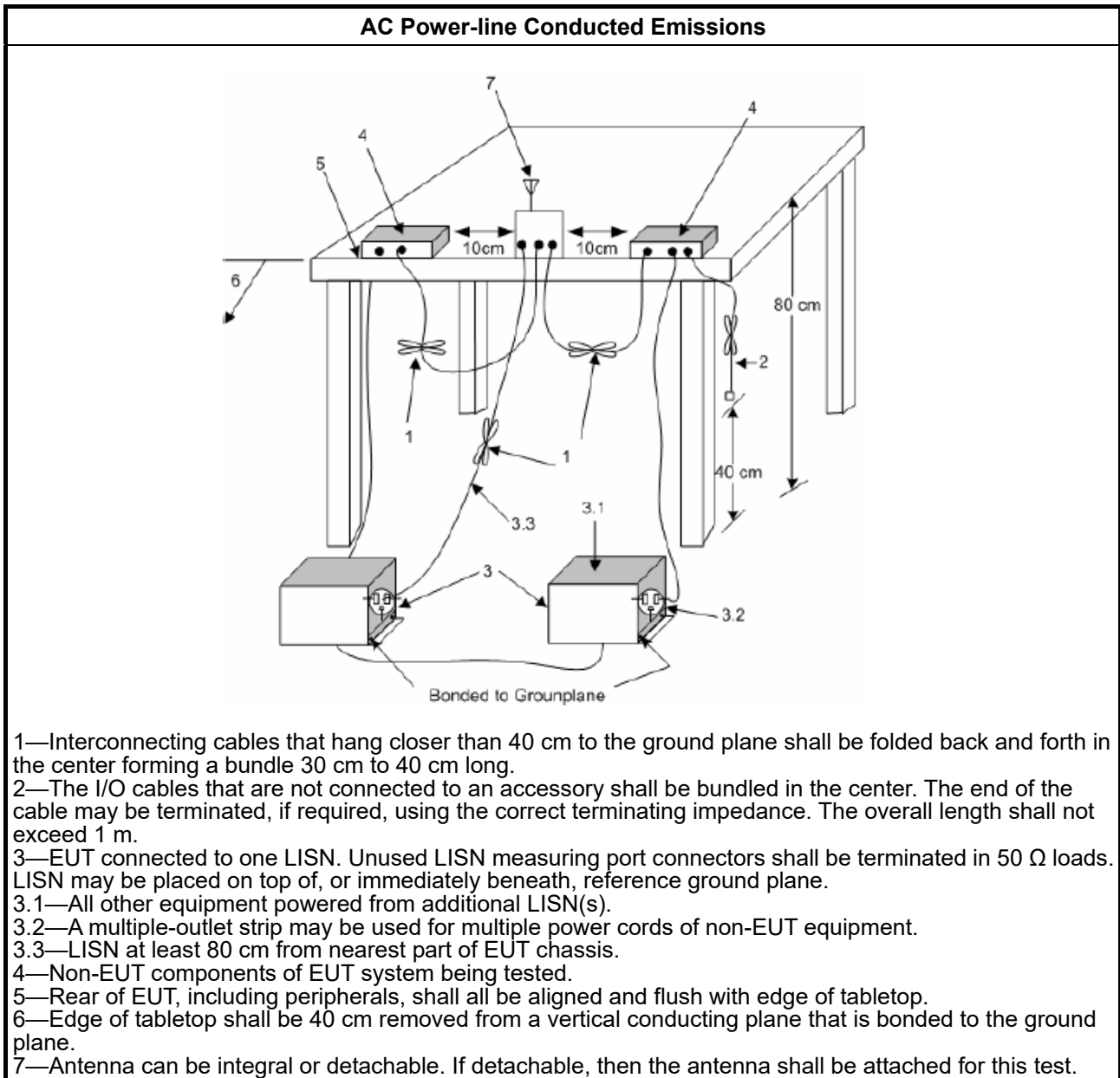

3.1.5 Measurement Results Calculation

The measured Level is calculated using:

- a. Corrected Reading: LISN Factor (LISN) + Attenuator (AT/AUX) + Cable Loss (CL) + Read Level (Raw) = Level
- b. Margin = -Limit + Level

3.1.6 Test Result of AC Power-line Conducted Emissions

Refer as Appendix A



3.2 Emissions in Restricted Frequency Bands

3.2.1 Emissions in Restricted Frequency Bands Limit

Restricted Band Emissions Limit			
Frequency Range (MHz)	Field Strength (uV/m)	Field Strength (dBuV/m)	Measure Distance (m)
0.009~0.490	2400/F(kHz)	48.5 - 13.8	300
0.490~1.705	24000/F(kHz)	33.8 - 23	30
1.705~30.0	30	29	30
30~88	100	40	3
88~216	150	43.5	3
216~960	200	46	3
Above 960	500	54	3

Note 1: Test distance for frequencies at or above 30 MHz, measurements may be performed at a distance other than the limit distance provided they are not performed in the near field and the emissions to be measured can be detected by the measurement equipment. When performing measurements at a distance other than that specified, the results shall be extrapolated to the specified distance using an extrapolation factor of 20 dB/decade (inverse of linear distance for field-strength measurements, inverse of linear distance-squared for power-density measurements).

Note 2: Test distance for frequencies at below 30 MHz, measurements may be performed at a distance closer than the EUT limit distance; however, an attempt should be made to avoid making measurements in the near field. When performing measurements below 30 MHz at a closer distance than the limit distance, the results shall be extrapolated to the specified distance by either making measurements at a minimum of two or more distances on at least one radial to determine the proper extrapolation factor or by using the square of an inverse linear distance extrapolation factor (40 dB/decade). The test report shall specify the extrapolation method used to determine compliance of the EUT.

Note 3: Using the distance of 1m during the test for above 18 GHz, and the test value to correct for the distance factor at 3m.

3.2.2 Measuring Instruments

Refer a test equipment and calibration data table in this test report.



3.2.3 Test Procedures

Test Method	
<ul style="list-style-type: none"> ▪ The average emission levels shall be measured in [duty cycle \geq 98 or duty factor]. 	
<ul style="list-style-type: none"> ▪ Refer as ANSI C63.10, clause 6.10.3 band-edge testing shall be performed at the lowest frequency channel and highest frequency channel within the allowed operating band. 	
<ul style="list-style-type: none"> ▪ For the transmitter unwanted emissions shall be measured using following options below: 	
	<ul style="list-style-type: none"> ▪ Refer as FCC KDB 558074, clause 8.6 for unwanted emissions into restricted bands.
	<input type="checkbox"/> Refer as FCC KDB 558074, clause 8.6 & C63.10 clause 11.12.2.5.1(trace averaging for duty cycle \geq 98%).
	<input type="checkbox"/> Refer as FCC KDB 558074, clause 8.6 & C63.10 clause 11.12.2.5.2(trace averaging + duty factor).
	<input checked="" type="checkbox"/> Refer as FCC KDB 558074, clause 8.6 & C63.10 clause 11.12.2.5.3(Reduced VBW \geq 1/T).
	<input type="checkbox"/> Refer as ANSI C63.10, clause 11.12.2.5.3 (Reduced VBW). VBW \geq 1/T, where T is pulse time.
	<input type="checkbox"/> Refer as ANSI C63.10, clause 7.5 average value of pulsed emissions.
	<input checked="" type="checkbox"/> Refer as FCC KDB 558074, clause 8.6 & C63.10 clause 11.12.2.4 measurement procedure peak limit.
<ul style="list-style-type: none"> ▪ For the transmitter band-edge emissions shall be measured using following options below: 	
	<ul style="list-style-type: none"> ▪ Refer as FCC KDB 558074 clause 8.7 & C63.10 clause 11.13.1, When the performing peak or average radiated measurements, emissions within 2 MHz of the authorized band edge may be measured using the marker-delta method described below.
	<ul style="list-style-type: none"> ▪ Refer as FCC KDB 558074, clause 8.7 (ANSI C63.10, clause 6.10.6) for marker-delta method for band-edge measurements.
	<ul style="list-style-type: none"> ▪ Refer as FCC KDB 558074, clause 8.7 for narrower resolution bandwidth (100kHz) using the band power and summing the spectral levels (i.e., 1 MHz).
	<ul style="list-style-type: none"> ▪ For conducted unwanted emissions into restricted bands (absolute emission limits). Devices with multiple transmit chains using options given below: (1) Measure and sum the spectra across the outputs or (2) Measure and add 10 log(N) dB
	<ul style="list-style-type: none"> ▪ For FCC KDB 662911 The methodology described here may overestimate array gain, thereby resulting in apparent failures to satisfy the out-of-band limits even if the device is actually compliant. In such cases, compliance may be demonstrated by performing radiated tests around the frequencies at which the apparent failures occurred.

3.2.4 Test Setup

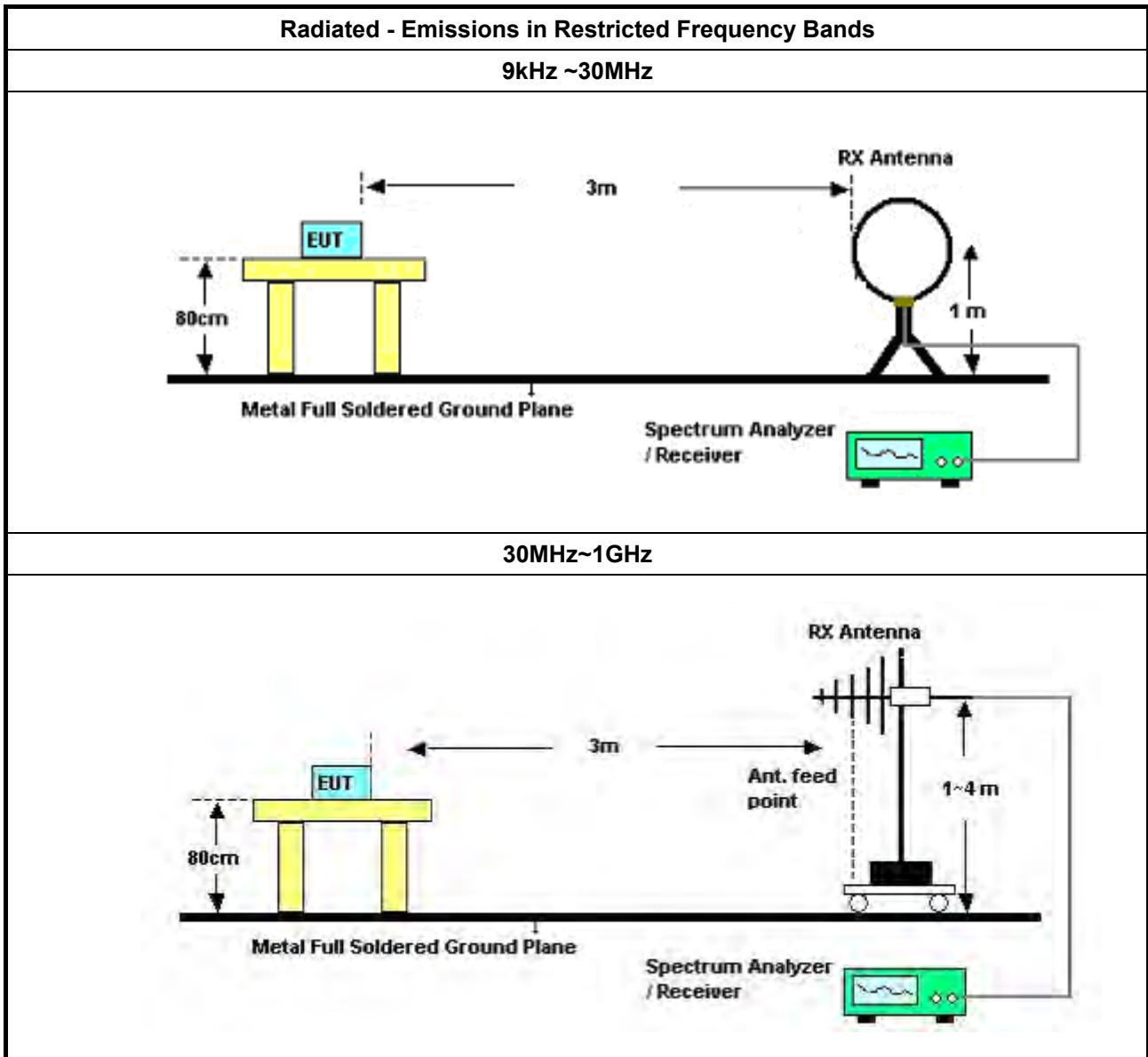

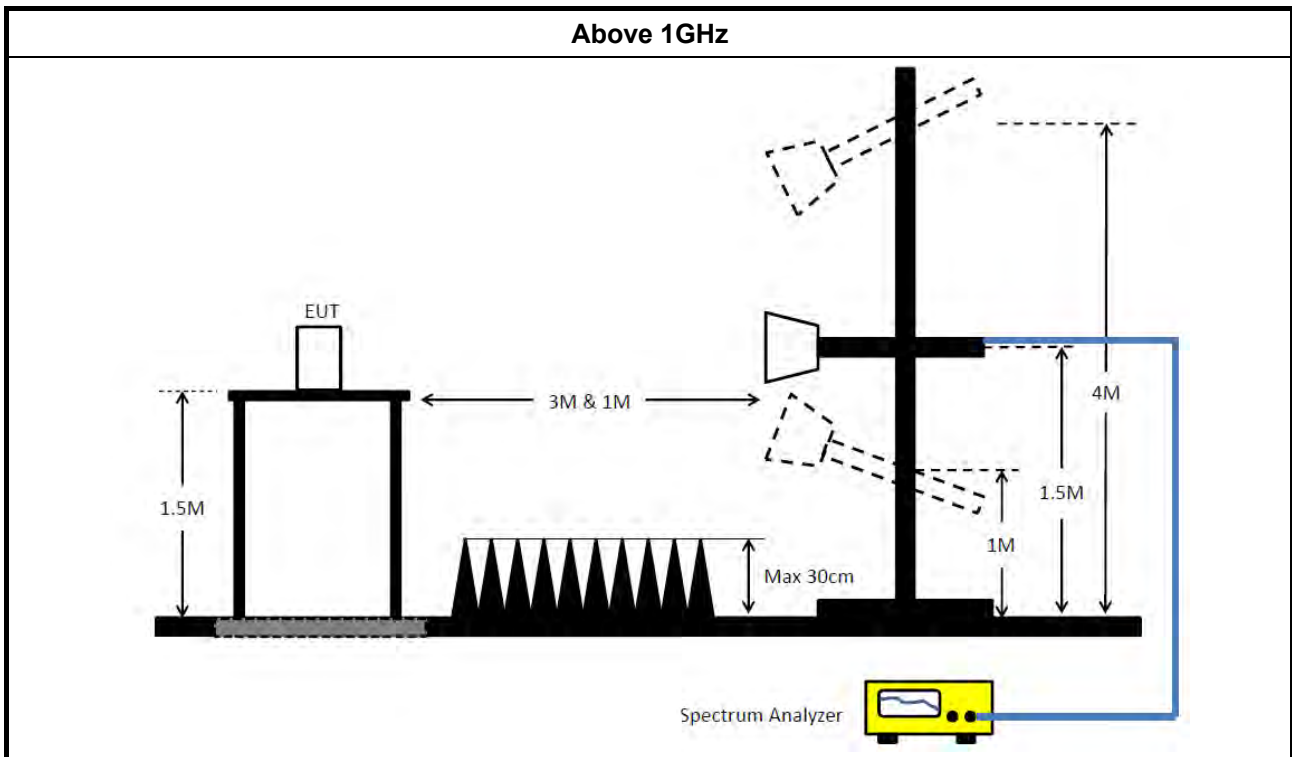

3.2.5 Measurement Results Calculation

The measured Level is calculated using:

Corrected Reading: Antenna factor (AF) + Cable loss (CL) + Read level (Raw) - Preamp factor (PA)(if applicable) = Level.

3.2.6 Emissions in Restricted Frequency Bands (Below 30MHz)

There is a comparison data of both open-field test site and alternative test site - semi-Anechoic chamber according to KDB414788 Radiated Test Site, and the result came out very similar.

All amplitude of spurious emissions that are attenuated by more than 20 dB below the permissible value has no need to be reported.

The radiated emissions were investigated from 9 kHz or the lowest frequency generated within the device, up to the 10th harmonic or 40 GHz, whichever is appropriate.

3.2.7 Test Result of Emissions in Restricted Frequency Bands

Refer as Appendix B



4 Test Equipment and Calibration Data

Instrument	Brand	Model No.	Serial No.	Characteristics	Calibration Date	Calibration Due Date	Remark
EMI Receiver	Agilent	N9038A	My52260123	9kHz ~ 8.4GHz	Mar. 03, 2021	Mar. 02, 2022	Conduction (CO01-CB)
LISN	F.C.C.	FCC-LISN-50-1 6-2	04083	150kHz ~ 100MHz	Jan. 06, 2021	Jan. 05, 2022	Conduction (CO01-CB)
LISN	Schwarzbeck	NSLK 8127	8127647	9kHz ~ 30MHz	Mar. 07, 2021	Mar. 06, 2022	Conduction (CO01-CB)
Pulse Limiter	Rohde&Schwarz	ESH3-Z2	100430	9kHz ~ 30MHz	Jan. 30, 2021	Jan. 29, 2022	Conduction (CO01-CB)
COND Cable	Woken	Cable	Low cable-CO01	9kHz ~ 30MHz	May 19, 2021	May 18, 2022	Conduction (CO01-CB)
Software	SPORTON	SENSE	V5.10	-	N.C.R.	N.C.R.	Conduction (CO01-CB)
3m Semi Anechoic Chamber NSA	TDK	SAC-3M	03CH05-CB	30 MHz ~ 1 GHz	Aug. 09, 2021	Aug. 08, 2022	Radiation (03CH05-CB)
Bilog Antenna with 6dB Attenuator	TESEQ & EMCI	CBL 6112D & N-6-06	35236 & AT-N0610	30MHz ~ 2GHz	Mar. 26, 2021	Mar. 25, 2022	Radiation (03CH05-CB)
Pre-Amplifier	EMCI	EMC330N	980331	20MHz ~ 3GHz	Apr. 27, 2021	Apr. 26, 2022	Radiation (03CH05-CB)
Spectrum Analyzer	R&S	FSP40	100304	9kHz ~ 40GHz	Nov. 10, 2020	Nov. 09, 2021	Radiation (03CH05-CB)
EMI Test Receiver	R&S	ESCS	826547/017	9kHz ~ 2.75GHz	Jun. 21, 2021	Jun. 20, 2022	Radiation (03CH05-CB)
RF Cable-low	Woken	RG402	Low Cable-04+23	30MHz~1GHz	Oct. 04, 2021	Oct. 03, 2022	Radiation (03CH05-CB)
Loop Antenna	Teseq	HLA 6120	24155	9kHz - 30 MHz	Apr. 14, 2021	Apr. 13, 2022	Radiation (03CH05-CB)
Test Software	SPORTON	SENSE	V5.10	-	N.C.R.	N.C.R.	Radiation (03CH05-CB)
3m Semi Anechoic Chamber VSWR	TDK	SAC-3M	03CH06-CB	1GHz ~18GHz 3m	Oct. 01, 2021	Sep. 30, 2022	Radiation (03CH06-CB)
Horn Antenna	SCHWARZBECK	BBHA9120D	BBHA 9120D-1292	1GHz~18GHz	Aug. 04, 2021	Aug. 03, 2022	Radiation (03CH06-CB)
Horn Antenna	Schwarzbeck	BBHA 9170	BBHA9170252	15GHz ~ 40GHz	Aug. 05, 2021	Aug. 04, 2022	Radiation (03CH06-CB)
Pre-Amplifier	Agilent	83017A	MY53270064	0.5GHz ~ 26.5GHz	May 06, 2021	May 05, 2022	Radiation (03CH06-CB)
Pre-Amplifier	MITEQ	TTA1840-35-HG	1864479	18GHz ~ 40GHz	Jul. 13, 2021	Jul. 12, 2022	Radiation (03CH06-CB)
Spectrum analyzer	R&S	FSP40	100080	9kHz~40GHz	Dec. 15, 2020	Dec. 14, 2021	Radiation (03CH06-CB)
RF Cable-high	Woken	RG402	High Cable-05	1GHz~18GHz	Oct. 04, 2021	Oct. 03, 2022	Radiation (03CH06-CB)



Instrument	Brand	Model No.	Serial No.	Characteristics	Calibration Date	Calibration Due Date	Remark
RF Cable-high	Woken	RG402	High Cable-05+24	1GHz~18GHz	Oct. 04, 2021	Oct. 03, 2022	Radiation (03CH06-CB)
RF Cable-high	Woken	RG402	High Cable-40G#1	18GHz ~ 40 GHz	Jul. 15, 2021	Jul. 14, 2022	Radiation (03CH06-CB)
RF Cable-high	Woken	RG402	High Cable-40G#2	18GHz ~ 40 GHz	Jul. 15, 2021	Jul. 14, 2022	Radiation (03CH06-CB)
Test Software	SPORTON	SENSE	V5.10	-	N.C.R.	N.C.R.	Radiation (03CH06-CB)

Note: Calibration Interval of instruments listed above is one year.
NCR means Non-Calibration required.



Summary

Mode	Result	Type	Freq (Hz)	Level (dBuV)	Limit (dBuV)	Margin (dB)	Condition
Mode 1	Pass	QP	150k	53.29	66.00	-12.71	Neutral

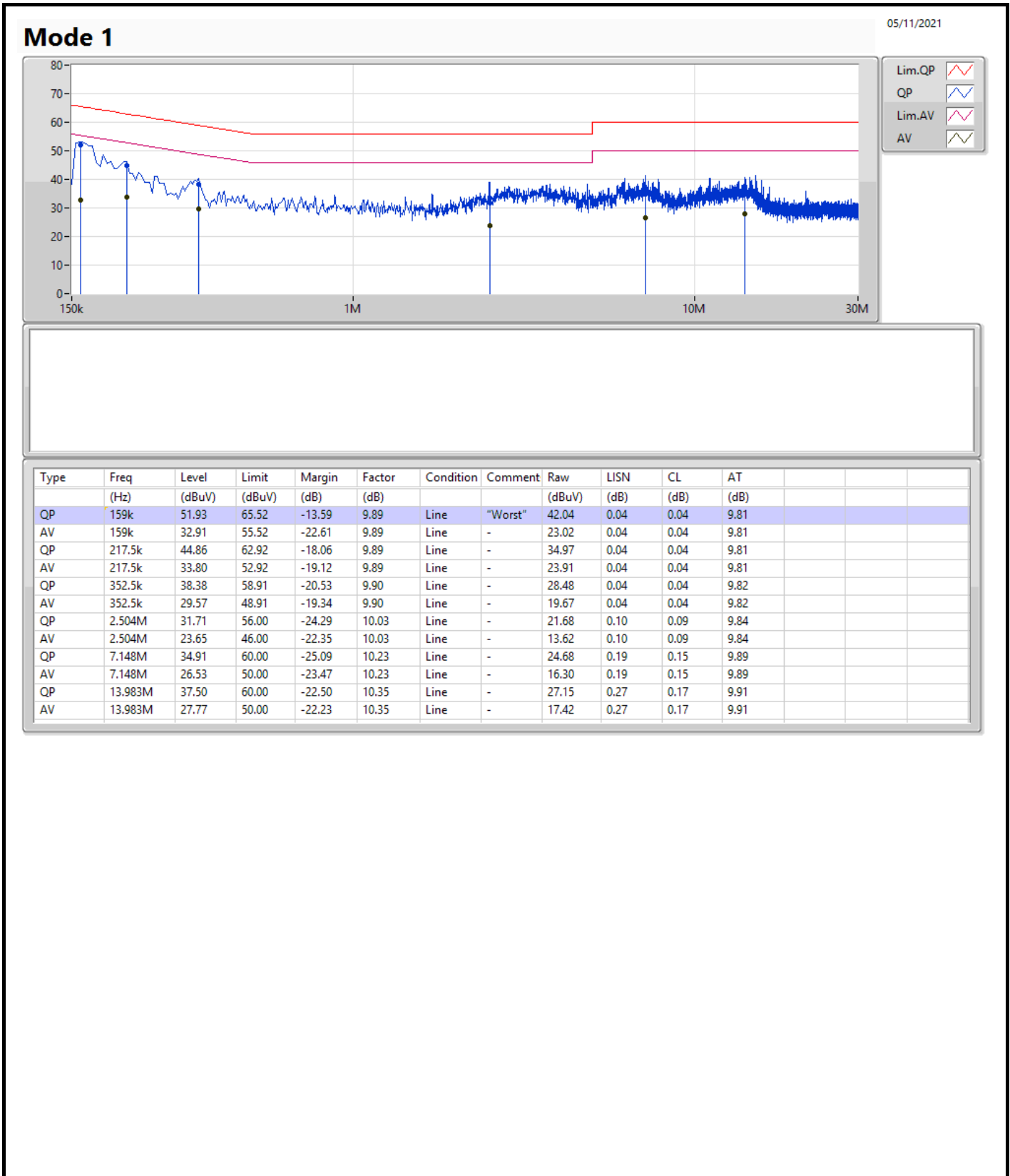

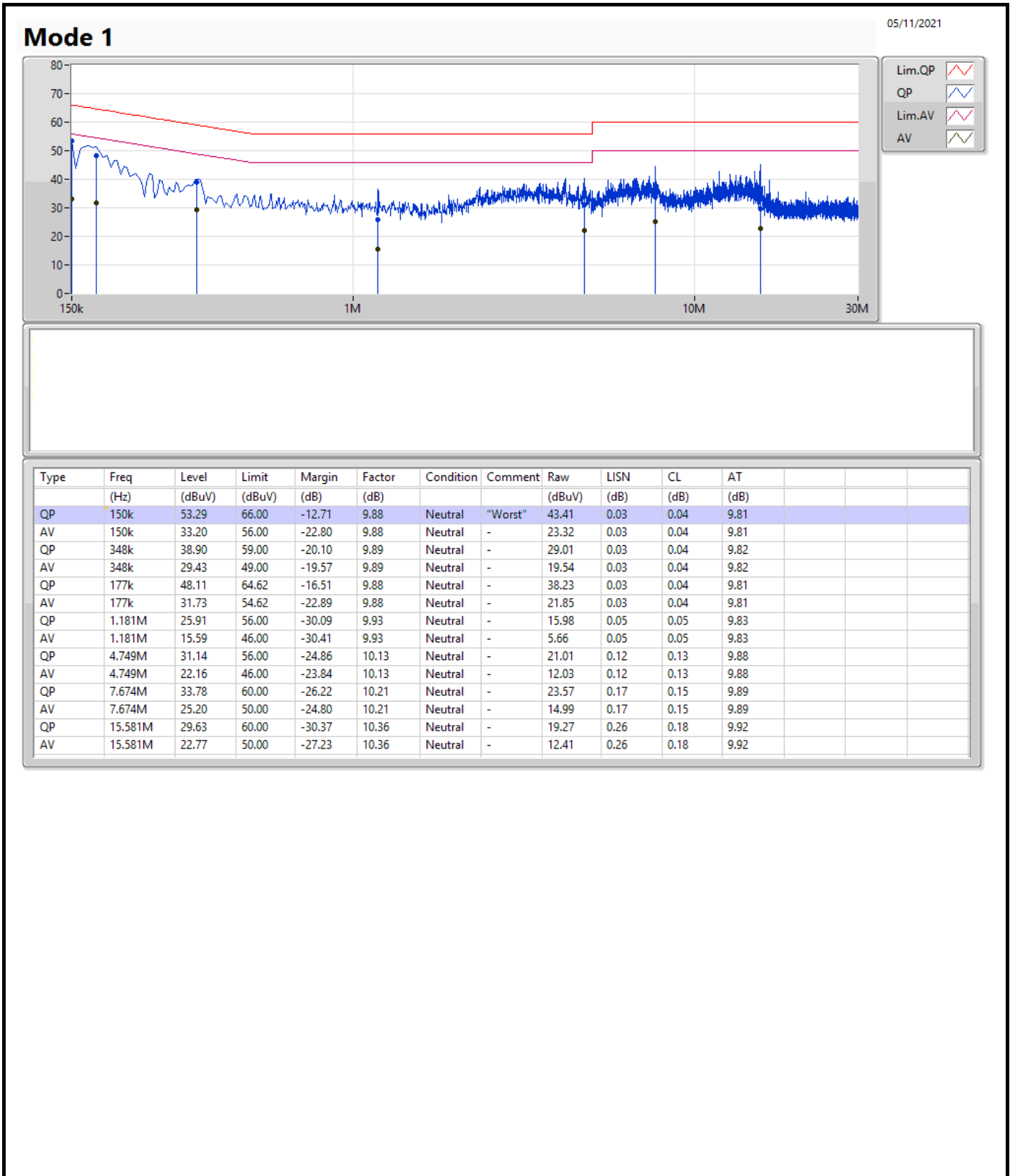



Summary

Mode	Result	Type	Freq (Hz)	Level (dBuV/m)	Limit (dBuV/m)	Margin (dB)	Condition
Mode 1	Pass	PK	58.13M	35.64	40.00	-4.36	Vertical

Mode 1

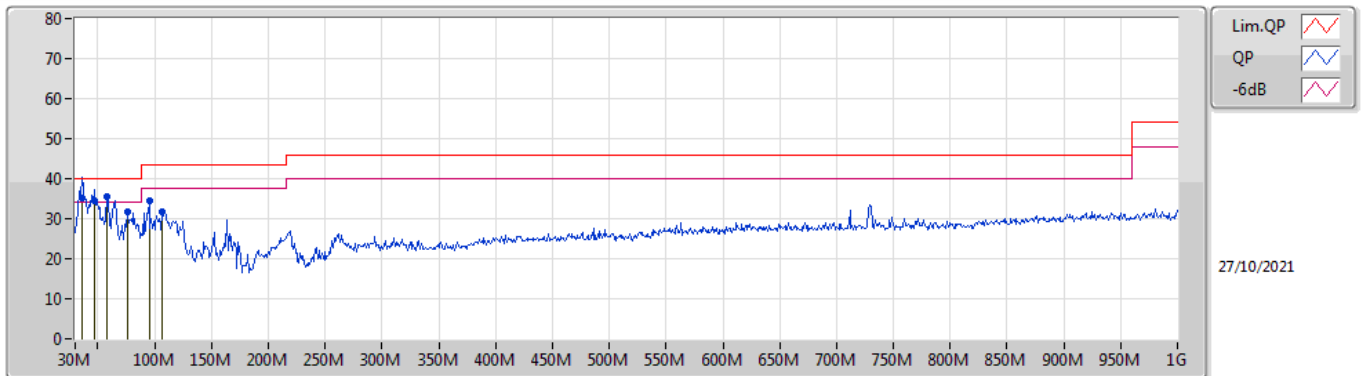

Type	Freq (Hz)	Level (dBuV/m)	Limit (dBuV/m)	Margin (dB)	Factor (dB/m)	Dist (m)	Condition	Azimuth (°)	Height (m)	Comment	Raw (dBuV/m)	AF (dB/m)	CL (dB)	PA (dB)
QP	35.82M	35.29	40.00	-4.71	-9.71	3	Vertical	113	1.00	-	45.00	20.99	0.90	31.60
QP	46.49M	34.62	40.00	-5.38	-15.38	3	Vertical	139	1.00	-	50.00	15.35	1.00	31.73
PK	58.13M	35.64	40.00	-4.36	-18.34	3	Vertical	314	1.00	"Worst"	53.98	12.33	1.16	31.83
PK	75.59M	31.82	40.00	-8.18	-18.28	3	Vertical	70	1.00	-	50.10	12.32	1.30	31.90
PK	94.99M	34.39	43.50	-9.11	-14.60	3	Vertical	220	1.25	-	48.99	15.79	1.50	31.89
PK	106.63M	31.75	43.50	-11.75	-12.95	3	Vertical	183	1.00	-	44.70	17.41	1.53	31.89

Mode 1

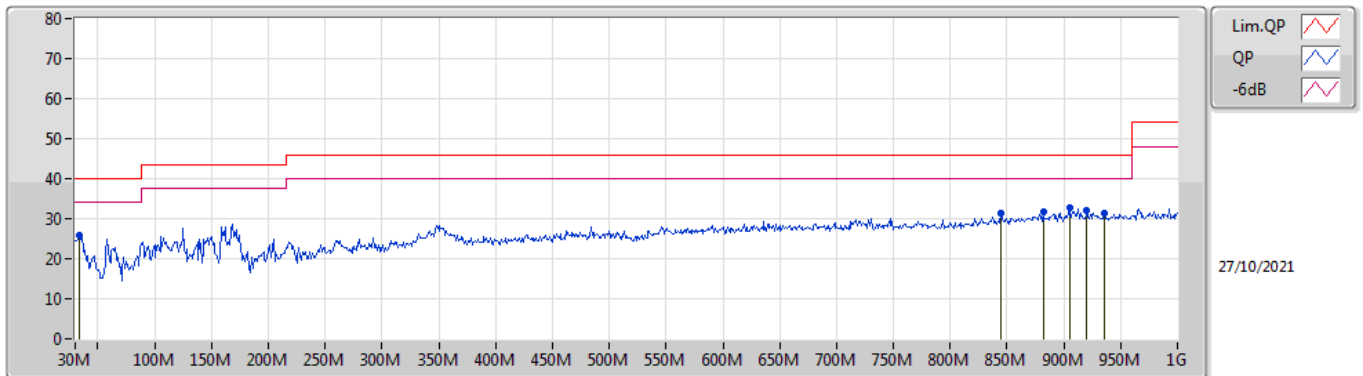

Type	Freq (Hz)	Level (dBuV/m)	Limit (dBuV/m)	Margin (dB)	Factor (dB/m)	Dist (m)	Condition	Azimuth (°)	Height (m)	Comment	Raw (dBuV/m)	AF (dB/m)	CL (dB)	PA (dB)
PK	33.88M	25.70	40.00	-14.30	-8.58	3	Horizontal	174	2.00	-	34.28	22.11	0.88	31.57
PK	844.8M	31.42	46.00	-14.58	-2.17	3	Horizontal	140	1.00	-	33.59	25.78	4.68	32.63
PK	881.66M	31.69	46.00	-14.31	-1.61	3	Horizontal	349	1.00	-	33.30	26.15	4.89	32.65
PK	904.94M	32.69	46.00	-13.31	-1.47	3	Horizontal	193	3.00	"Worst"	34.16	26.18	5.00	32.65
PK	920.46M	31.96	46.00	-14.04	-1.45	3	Horizontal	350	3.00	-	33.41	26.17	5.00	32.62
PK	935.98M	31.31	46.00	-14.69	-1.32	3	Horizontal	166	1.50	-	32.63	26.28	5.00	32.60



Summary

Mode	Result	Type	Freq (Hz)	Level (dBuV/m)	Limit (dBuV/m)	Margin (dB)	Dist (m)	Condition	Azimuth (°)	Height (m)	Comments
2.4-2.4835GHz	-	-	-	-	-	-	-	-	-	-	-
802.11b_Nss1,(1Mbps)_2TX	Pass	AV	4.87404G	53.13	54.00	-0.87	3	Vertical	317	1.00	-

802.11b_Nss1,(1Mbps)_2TX

2437MHz_TX

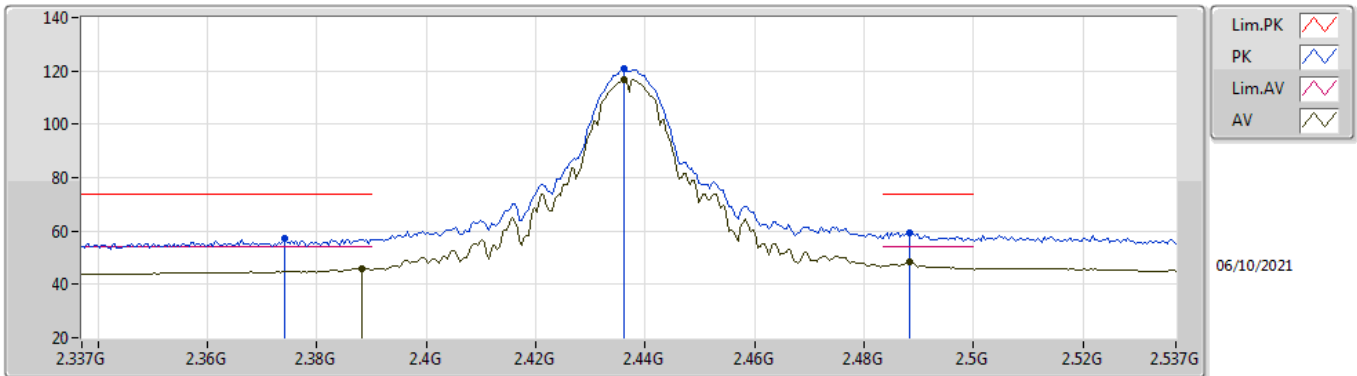

EUT_V_2TX
Setting 108
06-F-S-5

Type	Freq (Hz)	Level (dBuV/m)	Limit (dBuV/m)	Margin (dB)	Raw (dBuV)	Dist (m)	Condition	Azimuth (°)	Height (m)	Comment	AF (dB)	CL (dB)	PA (dB)
PK	2.3742G	57.19	74.00	-16.81	26.53	3	Vertical	122	2.06	-	27.61	3.05	-
AV	2.3882G	45.87	54.00	-8.13	15.30	3	Vertical	122	2.06	-	27.49	3.08	-
PK	2.4362G	120.61	Inf	-Inf	90.21	3	Vertical	122	2.06	-	27.26	3.14	-
AV	2.4362G	116.77	Inf	-Inf	86.37	3	Vertical	122	2.06	-	27.26	3.14	-
PK	2.4882G	59.53	74.00	-14.47	29.06	3	Vertical	122	2.06	-	27.28	3.19	-
AV	2.4882G	48.34	54.00	-5.66	17.87	3	Vertical	122	2.06	-	27.28	3.19	-

802.11b_Nss1,(1Mbps)_2TX

2437MHz_TX

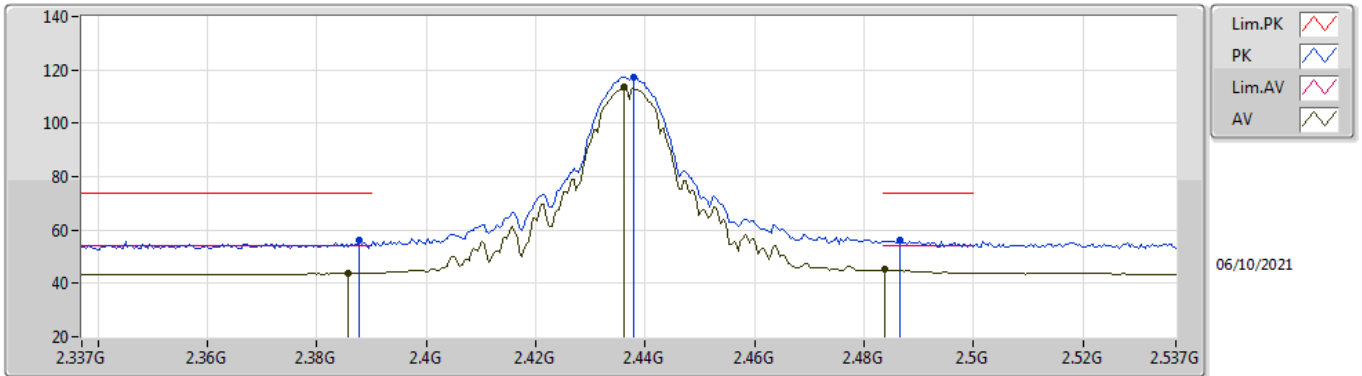

EUT_V_2TX
Setting 108
06-F-S-5

Type	Freq (Hz)	Level (dBuV/m)	Limit (dBuV/m)	Margin (dB)	Raw (dBuV)	Dist (m)	Condition	Azimuth (°)	Height (m)	Comment	AF (dB)	CL (dB)	PA (dB)
PK	2.3878G	55.95	74.00	-18.05	25.37	3	Horizontal	203	2.20	-	27.50	3.08	-
AV	2.3858G	43.95	54.00	-10.05	13.37	3	Horizontal	203	2.20	-	27.51	3.07	-
PK	2.4378G	117.38	Inf	-Inf	86.99	3	Horizontal	203	2.20	-	27.25	3.14	-
AV	2.4362G	113.44	Inf	-Inf	83.04	3	Horizontal	203	2.20	-	27.26	3.14	-
PK	2.4866G	56.02	74.00	-17.98	25.56	3	Horizontal	203	2.20	-	27.27	3.19	-
AV	2.4838G	45.18	54.00	-8.82	14.73	3	Horizontal	203	2.20	-	27.27	3.18	-

802.11b_Nss1,(1Mbps)_2TX

2437MHz_TX

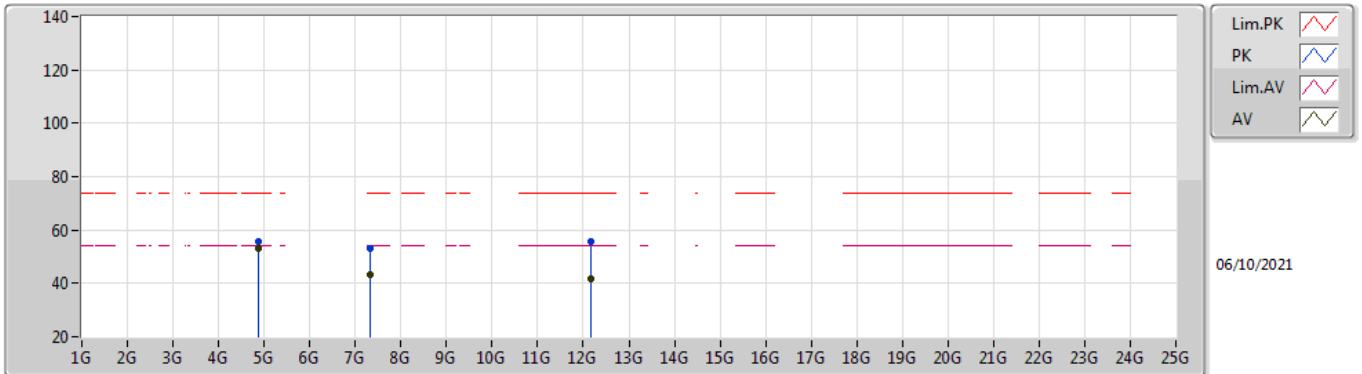

EUT Y_2TX
Setting 108
06-F-S-5

Type	Freq (Hz)	Level (dBuV/m)	Limit (dBuV/m)	Margin (dB)	Raw (dBuV)	Dist (m)	Condition	Azimuth (°)	Height (m)	Comment	AF (dB)	CL (dB)	PA (dB)
PK	4.87388G	55.85	74.00	-18.15	51.82	3	Vertical	317	1.00	-	31.05	5.00	32.02
AV	4.87404G	53.13	54.00	-0.87	49.10	3	Vertical	317	1.00	-	31.05	5.00	32.02
PK	7.31188G	53.33	74.00	-20.67	44.35	3	Vertical	345	2.11	-	36.35	6.10	33.47
AV	7.31176G	43.03	54.00	-10.97	34.05	3	Vertical	345	2.11	-	36.35	6.10	33.47
PK	12.17588G	55.94	74.00	-18.06	42.73	3	Vertical	360	3.00	-	38.77	8.60	34.16
AV	12.17636G	41.79	54.00	-12.21	28.58	3	Vertical	360	3.00	-	38.77	8.60	34.16

802.11b_Nss1,(1Mbps)_2TX

2437MHz_TX

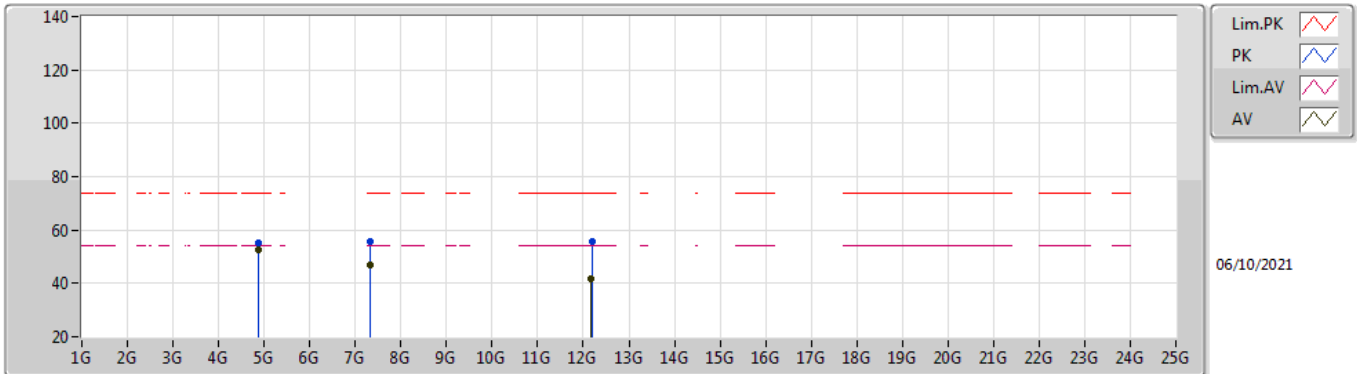

EUT V_2TX
Setting 108
06-F-S-5

Type	Freq (Hz)	Level (dBuV/m)	Limit (dBuV/m)	Margin (dB)	Raw (dBuV)	Dist (m)	Condition	Azimuth (°)	Height (m)	Comment	AF (dB)	CL (dB)	PA (dB)
PK	4.874G	55.12	74.00	-18.88	51.09	3	Horizontal	54	2.13	-	31.05	5.00	32.02
AV	4.874G	52.48	54.00	-1.52	48.45	3	Horizontal	54	2.13	-	31.05	5.00	32.02
PK	7.31188G	55.62	74.00	-18.38	46.64	3	Horizontal	251	2.25	-	36.35	6.10	33.47
AV	7.31172G	47.08	54.00	-6.92	38.10	3	Horizontal	251	2.25	-	36.35	6.10	33.47
PK	12.19196G	55.64	74.00	-18.36	42.46	3	Horizontal	0	1.80	-	38.72	8.61	34.15
AV	12.17612G	41.85	54.00	-12.15	28.64	3	Horizontal	0	1.80	-	38.77	8.60	34.16