

AX6000 Product

Antenna passive test report

Product type: AX6000-2dBi

manufacturer: Dongguan Renfeng Electronic Technology Co., LTD

Tester: Xiao Yupeng

Antenna version: V1.0

April 24, 2023

CONTENTS

1 Document Description	- 1 -
2 Test Purpose	- 1 -
3 Basic Description	- 1 -
3.1 Test environment description	- 1 -
3.2 Basic description of the antenna to be tested	- 3 -
3.3 UT Antenna	- 3 -
3.4 Test Procedure	- 5 -
4. Network Analyzer Results	- 7 -
4.1 2.4G WIFI Antenna	- 7 -
4.1.1 Frequency ,VSWR and Return Loss(S11)	- 7 -
4.1.2 2.4G Antennas Isolation	- 9 -
4.2 5G WIFI Antenna	- 11 -
4.2.1 Frequency ,VSWR and Return Loss(S11)	- 11 -
4.2.2 5G Antennas Isolation	- 13 -
5. Passive Test Results	- 16 -
5.1 2.45GHz Radiation pattern test results	- 16 -
5.2 2.4G Gain and Efficiency	- 19 -
5.3 5.5GHz Radiation pattern test results	- 20 -
5.4 5G Gain and Efficiency	- 23 -

1 Document Description

This document is used for the project team to evaluate antenna performance. The passive test part can be provided in the simulation stage or simulation test stage, and the active test part should provide the whole machine.

2 Test Purpose

Confirm antenna requirements, specify test system and test items, and comprehensively evaluate the match between antenna design and product to ensure the performance of RF link.

3 Basic Description

3.1 Test environment description

Project	Configuration
Laboratory name	<i>Renfeng Antenna factory laboratory,</i>
Testing Software	<i>XH-IOE test system, Figure 2</i>
Chamber Specification	<i>24-probe near field OTA test system based on SATIMO, 6m*3m*3m, 600MHz-8GHz</i>
Test Instrument	<i>the network analyzer(E5071C), Figure 3</i>
Relative coordinates	<i>H-Plane: XY Plane, E1-plane: XZ Plane, E2-plane: YZ Plane, Figure 2</i>

**Directly connecting an instrument to a PC with LAN may require a special LAN Crossover Cable.*

Some instruments, and multiple instrument installations, require interface hardware, such as a GPIB PC plug-in card, PCIe interface, USB to GPIB converter, LAN/GPIB gateway, or LAN router. Some examples are shown below.

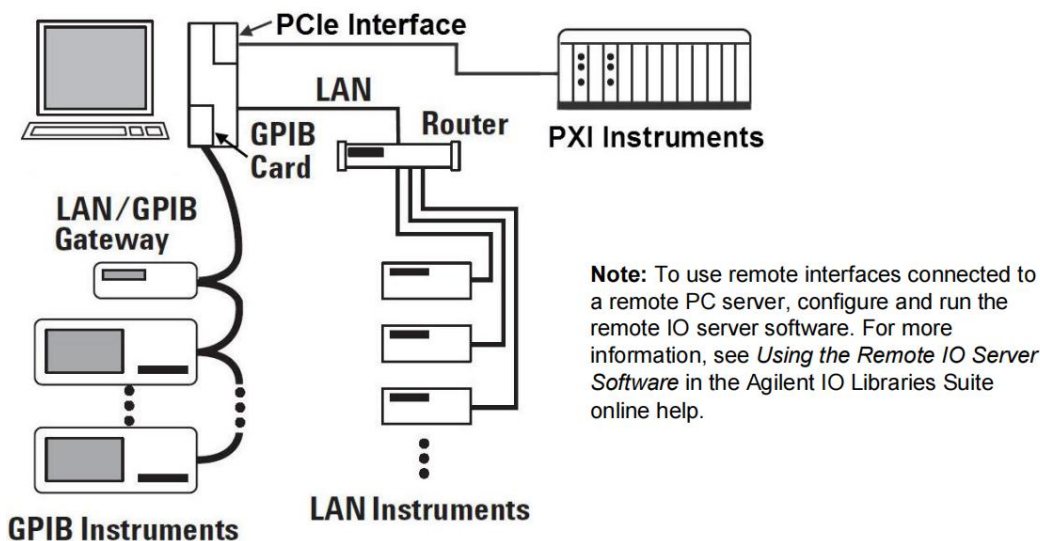

Figure 1 Device connection diagram

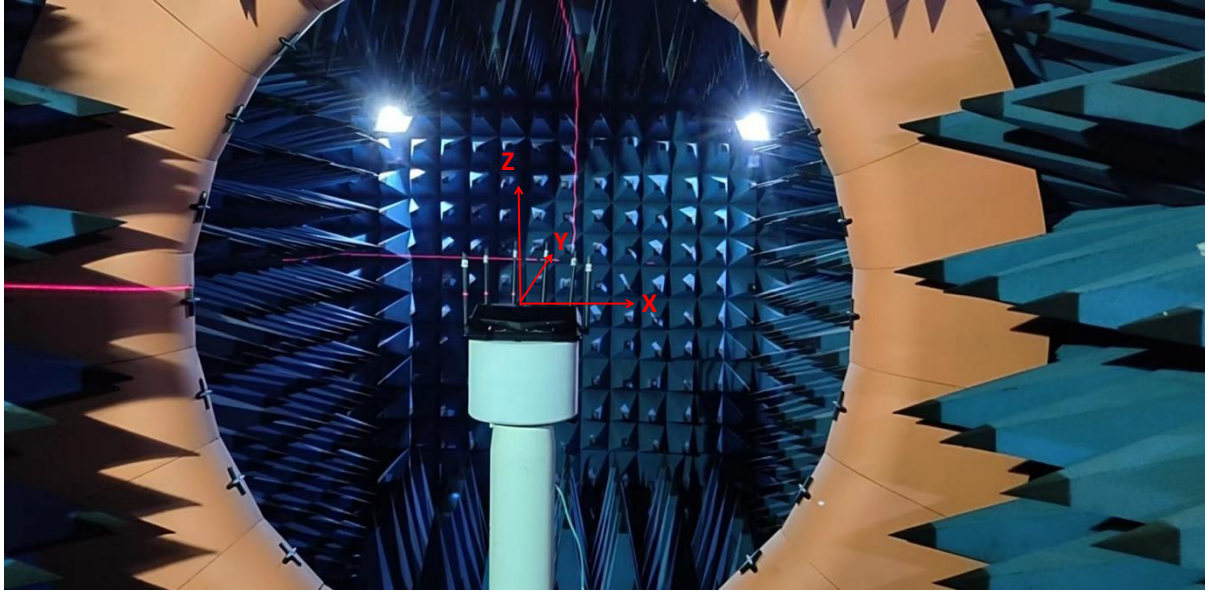

Figure 2 Relative coordinate
 H-Plane: XY Plane, E1-plane: XZ Plane, E2-plane: YZ Plane

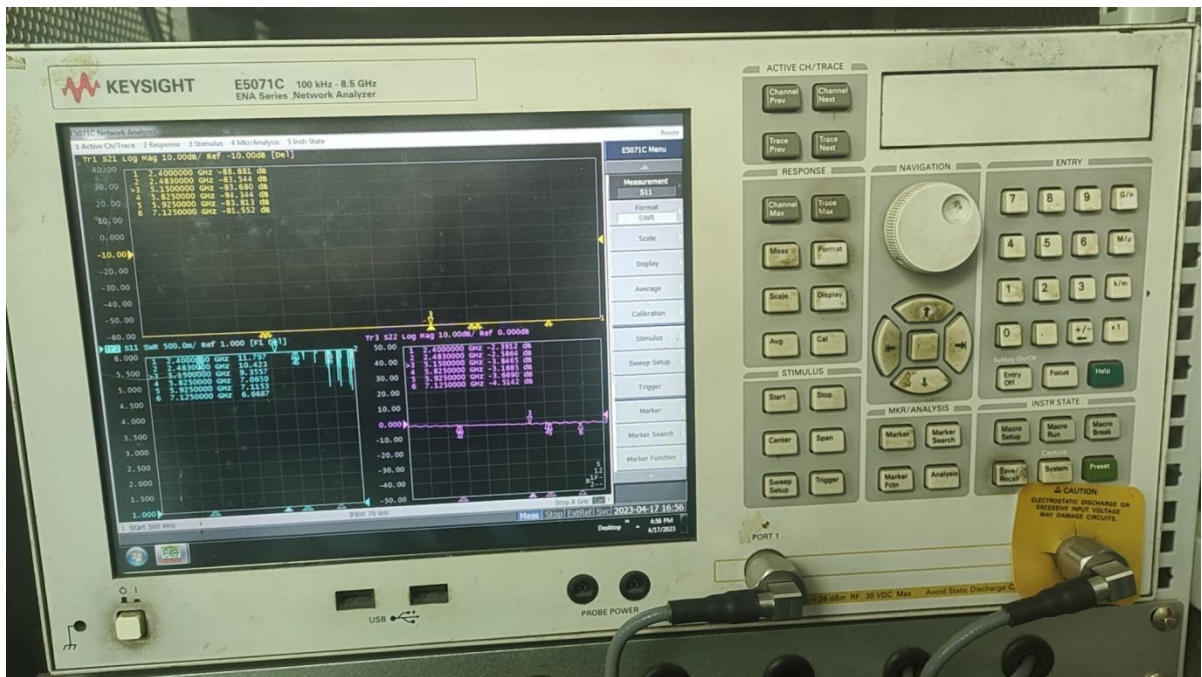

Figure 3 Network Analyzer

Equipment	Manufacture	Model Number	Serial Number	Calibrated until
Network Analyzer	AGILENT	E5071C	MY41440323	2023/12/06
Chamber	XH	Wave Studio	RFYQ091	2023/12/06

3.2 Basic description of the antenna to be tested



Mark	Details	Serial number
ANT1	2.4G 2dBi 1.37 red wire, length 75mm+IPEX	U00T01S039N01804
ANT2	2.4G 2dBi 1.37 gray wire, length 295mm+IPEX	U00T01S039N01809
ANT3	5G 2dBi 1.37 black wire, length 75mm+IPEX	U00T01S039N01809
ANT4	5G 2dBi 1.37white wire,length 125mm+IPEX	U00T01S039N01806
ANT5	5G 2dBi 1.37yellow wire,length170mm+IPEX	U00T01S039N01807
ANT6	2.4G 2dBi 1.37gray wire, length 85mm+IPEX	U00T01S039N01810
ANT7	5G 2dBi 1.37black wire, length 285mm+IPEX	U00T01S039N01810
ANT8	2.4G 2dBi 1.37blue wire,length185mm+IPEX	U00T01S039N01805

3.3 UT Antenna

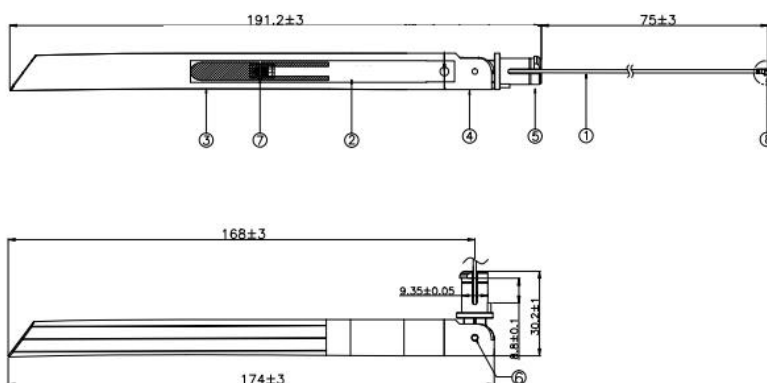

Figure 4 ANT1 sketch map

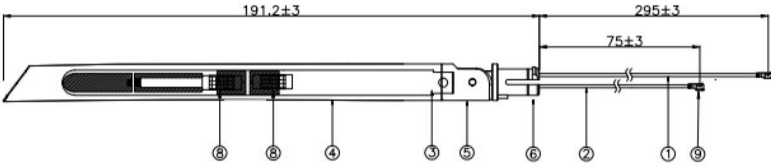

Figure5 ANT2&ANT3sketch map

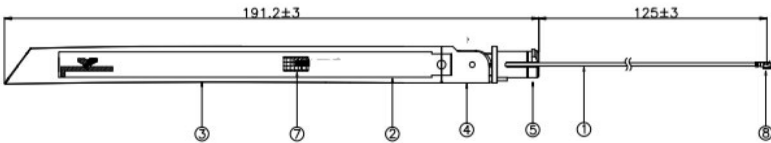

Figure6 ANT4sketch map

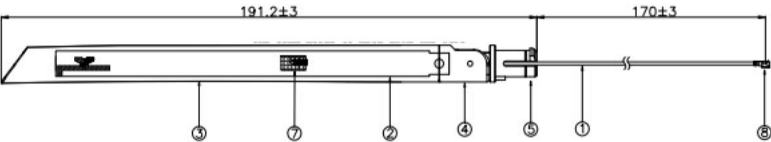

Figure7 ANT5sketch map

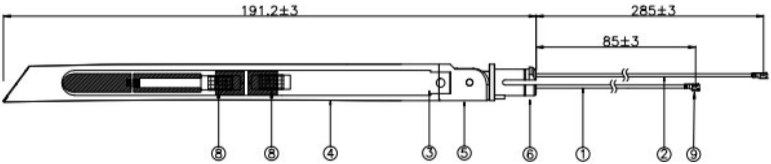

Figure8 ANT6&ANT7sketch map

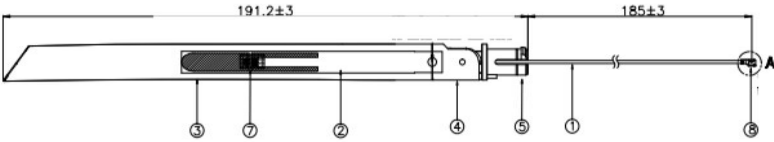
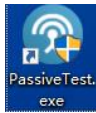

Figure9 ANT8sketch map

3.4 Test Procedure



1. Open the passive test software
2. Swing the antenna under test to the center of the turntable, and align the phase center of the antenna with the laser center, as shown in the figure below:

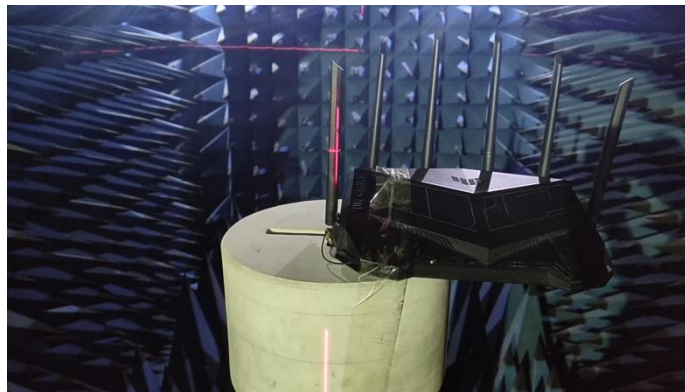

Figure 10. ANT1 is placed in the center of the turntable during testing

3. After closing the screen door, enter the start frequency point and end frequency point on the software interface to start the test. After the test is completed, save the data file XXX.txt.

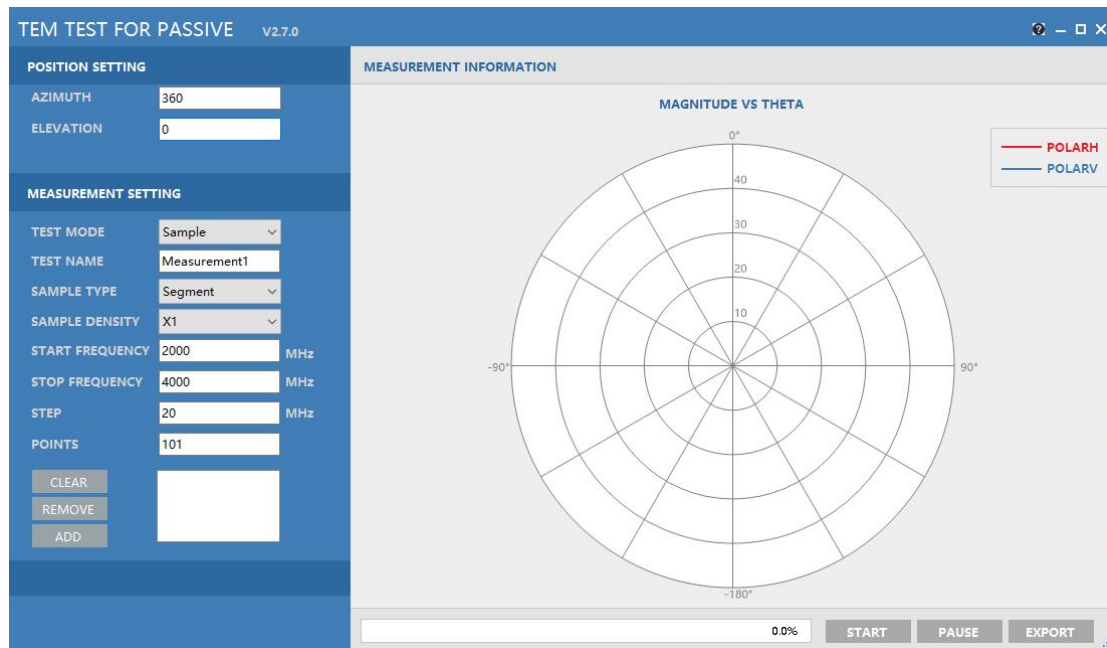

Figure11 Software test interface

4. Open the software TemRadioDP and test file Import: click Project(P) in the menu bar =>Import;
5. After the calculation is completed, the software interface automatically generates 2D/3D graph, gain, efficiency and other parameters;

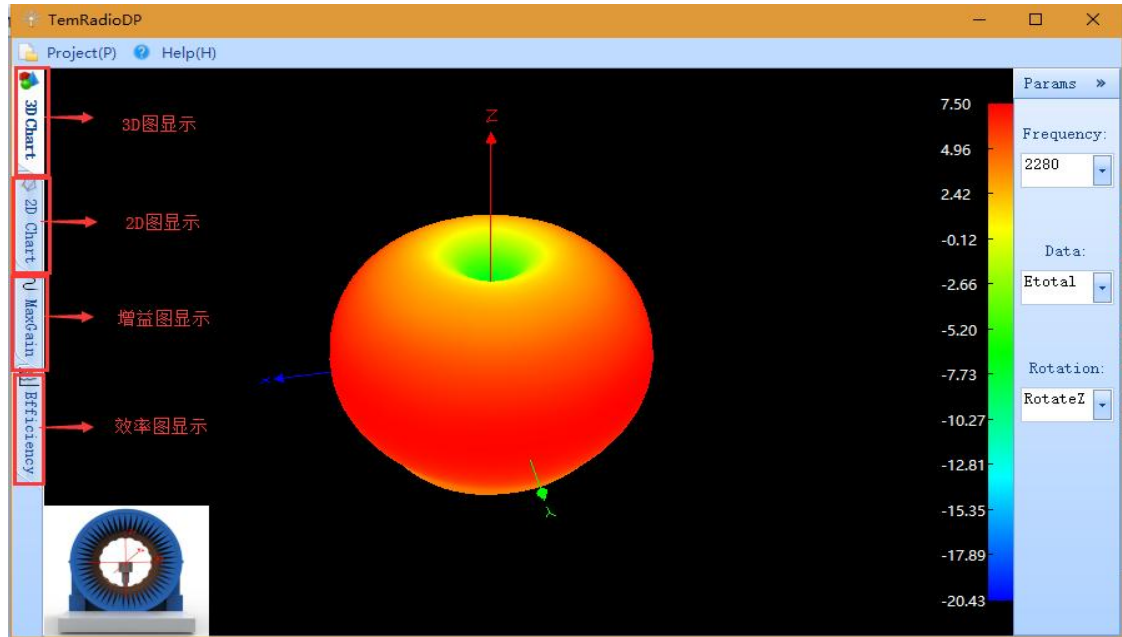

Figure12 Viewing the software calculation results

4. Network Analyzer Results

4.1 2.4G WIFI Antenna

4.1.1 Frequency, VSWR and Return Loss(S11)

(requirement: 2400-2500MHz, S11 < -10, VSWR < 1.92)

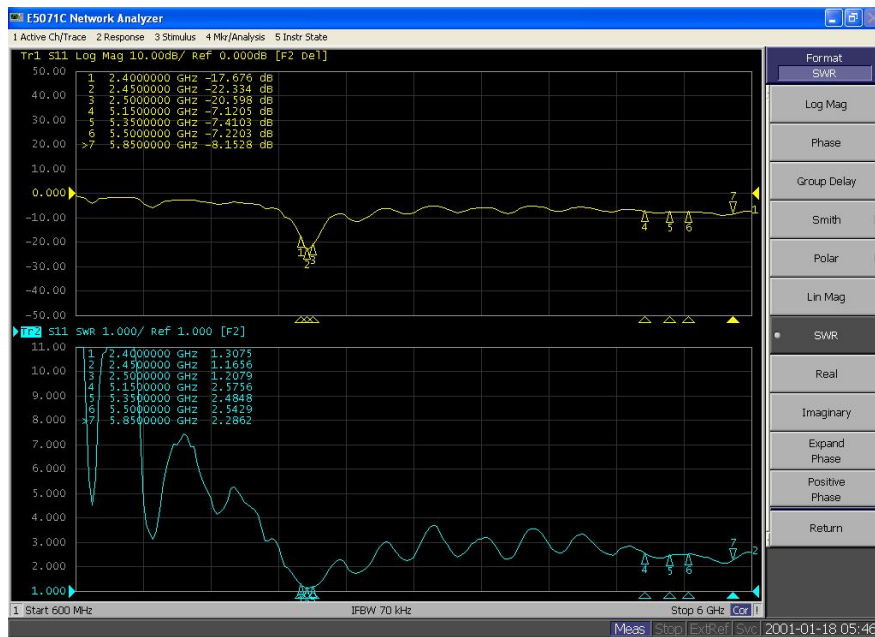

Figure 13 ANT1(2.4G) Return Loss and VSWR

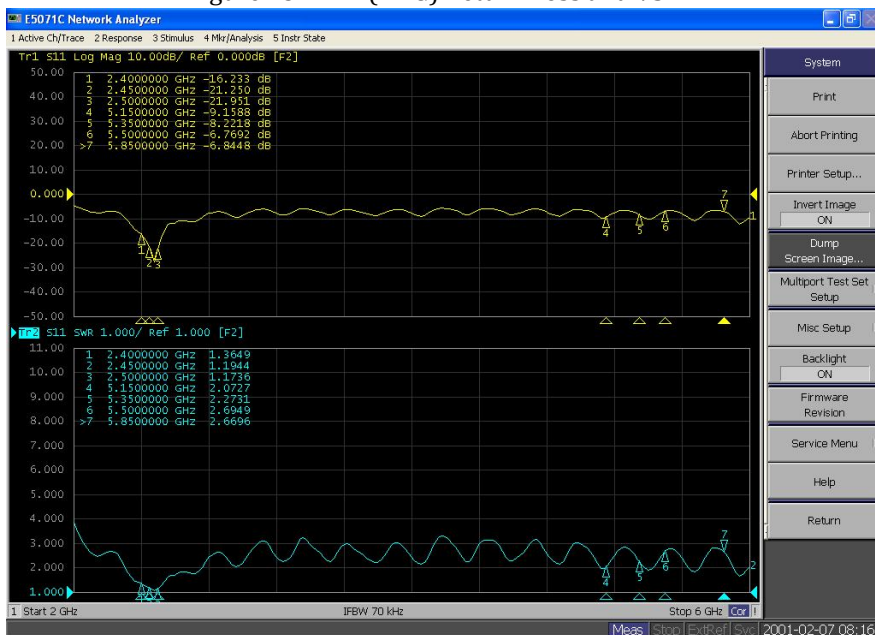

Figure 14 ANT2(2.4G) Return Loss and VSWR

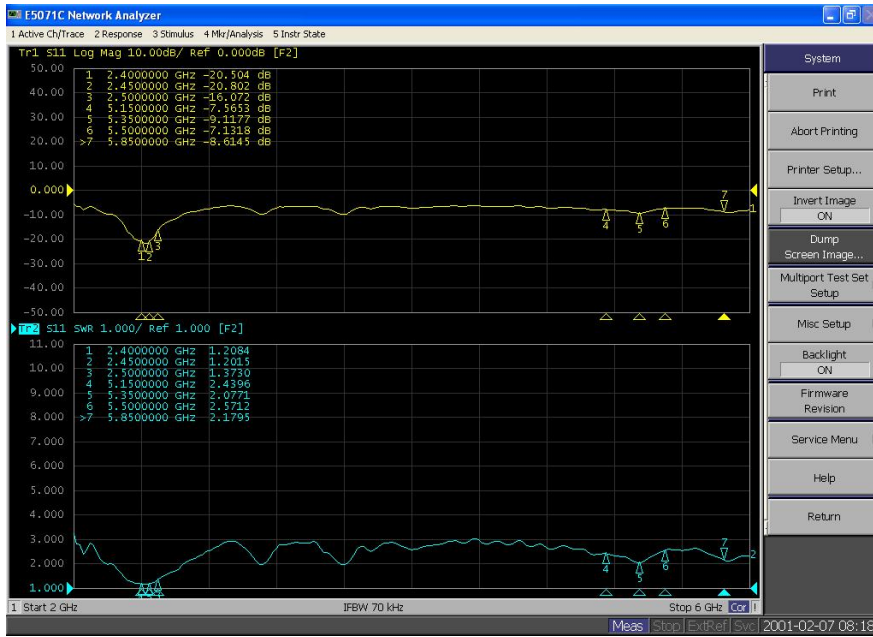

Figure 15 ANT6(2.4G) Return Loss and VSWR

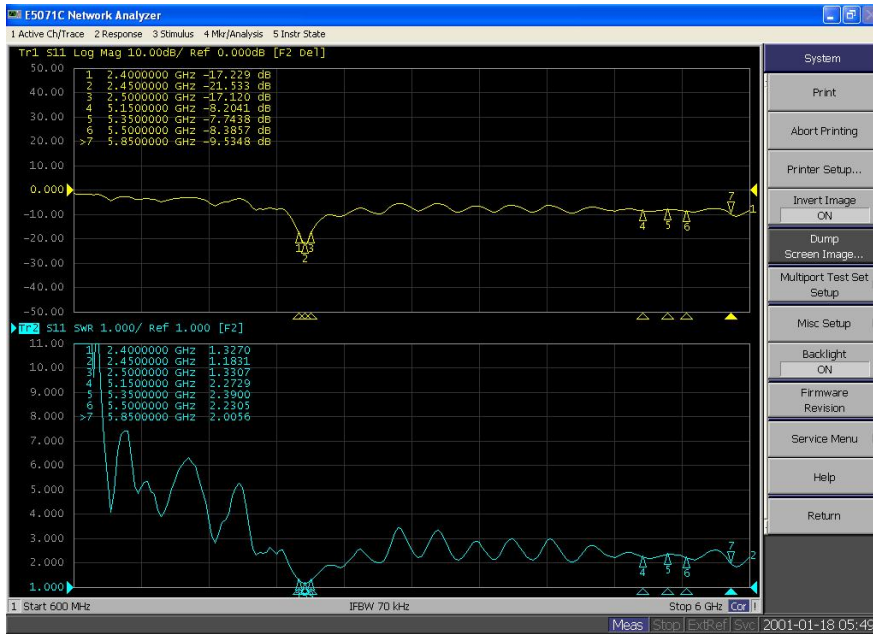

Figure16 ANT8(2.4G) Return Loss and VSWR

4.1.2 2.4G Antennas Isolation

(requirement:2400-2500MHz,Isolation<-20)

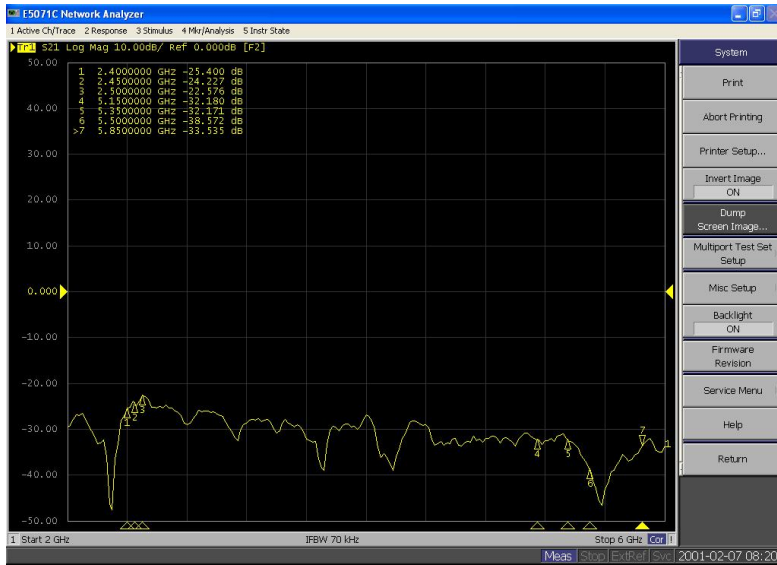

Figure17 Isolation between ANT1 and ANT2

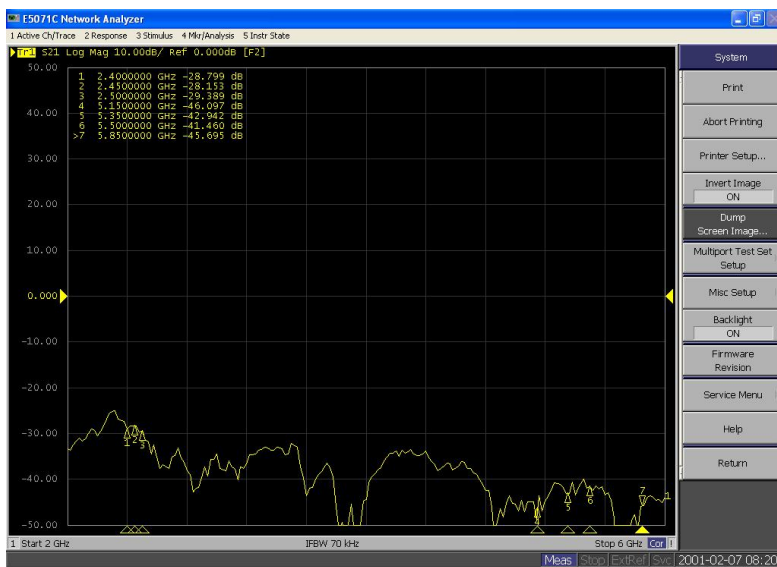

Figure18 Isolation between ANT1 and ANT6

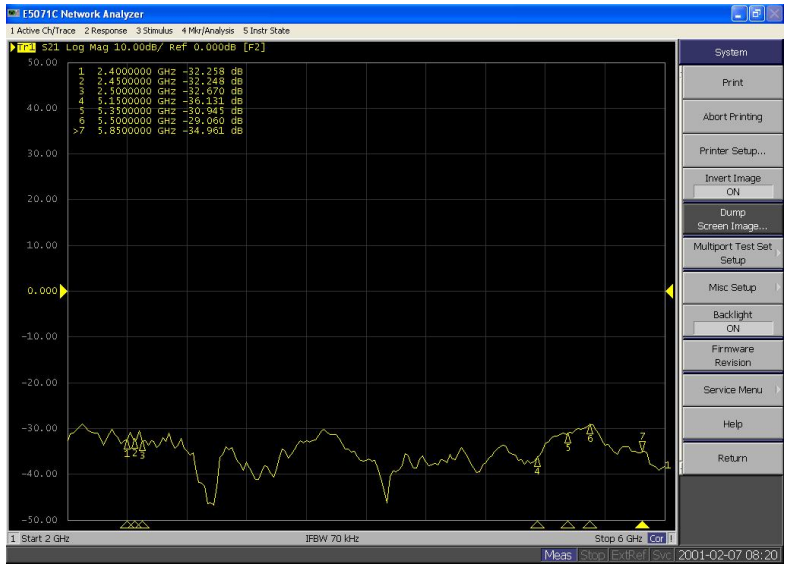

Figure19 Isolation between ANT1 and ANT8

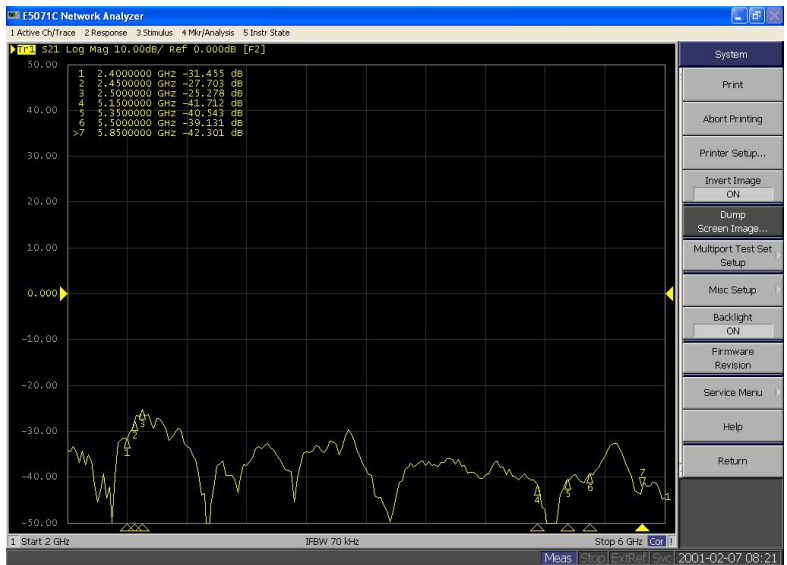

Figure20 Isolation between ANT2 and ANT6

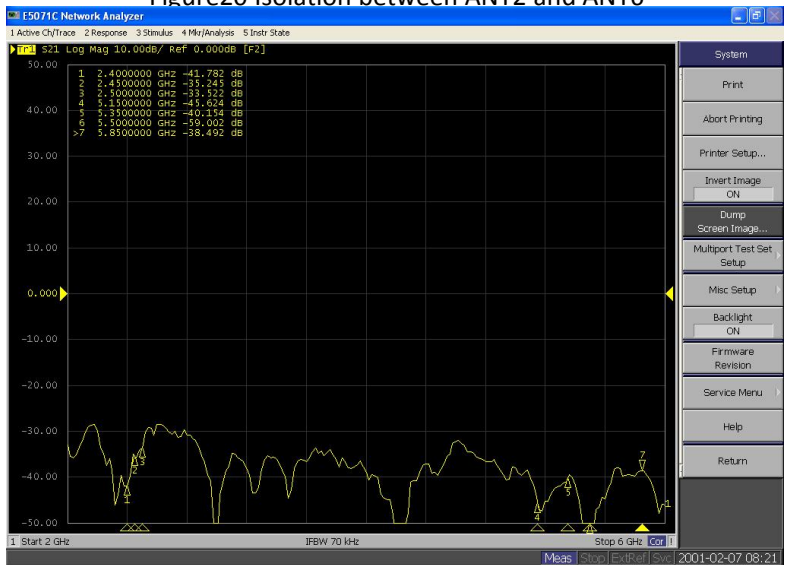

Figure21 Isolation between ANT2 and ANT8

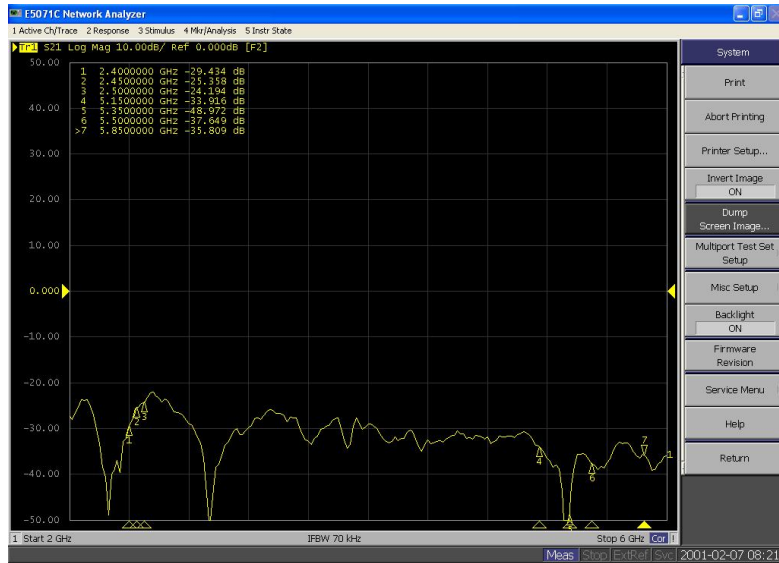

Figure22 Isolation between ANT6 and ANT8

4.2 5G WIFI Antenna

4.2.1 Frequency ,VSWR and Return Loss(S11)

(requirement:5150-5850MHz,S11<-10,VSWR<1.92)



Figure 23 ANT3(5G) Return Loss and VSWR



Figure 24 ANT4(5G) Return Loss and VSWR

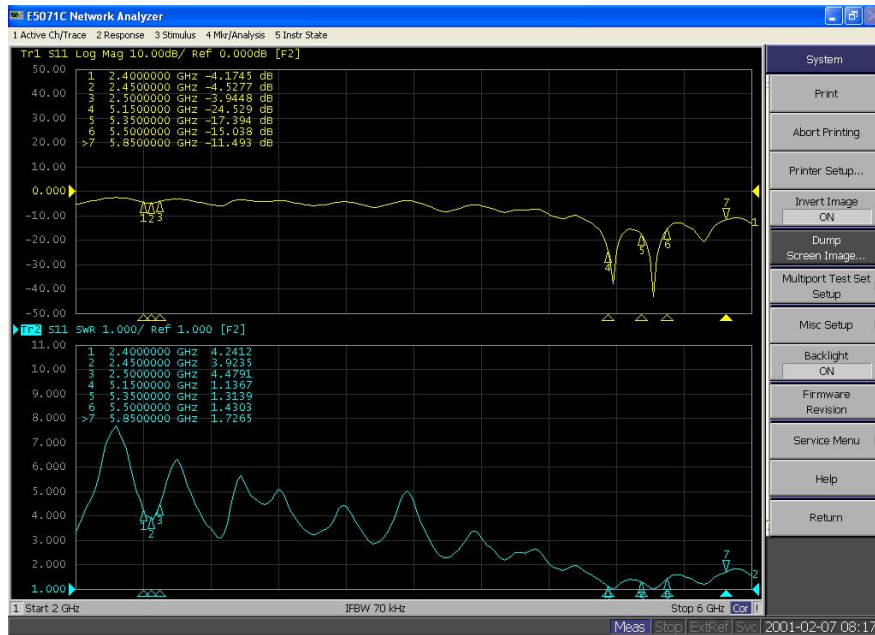

Figure 25 ANT5(5G) Return Loss and VSWR

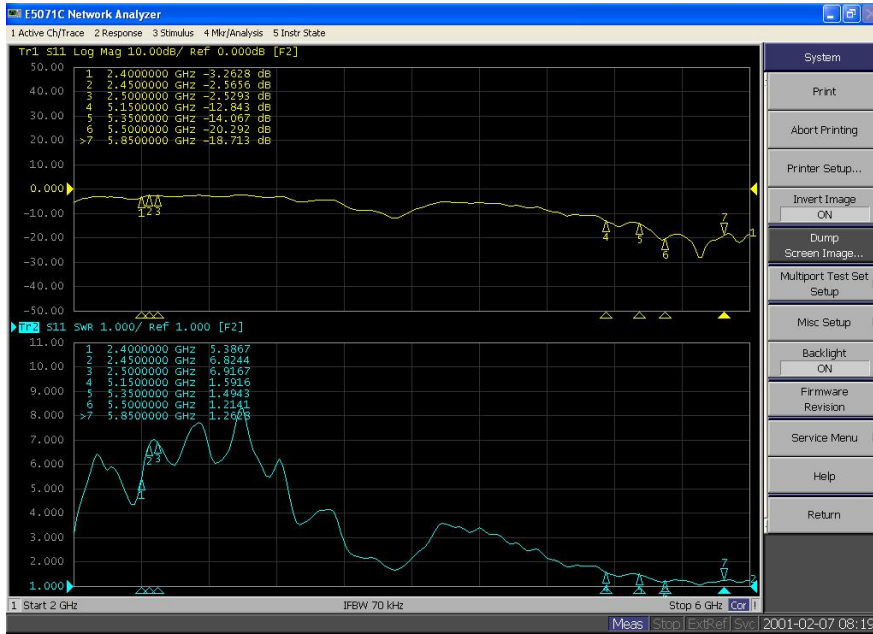

Figure26 ANT7(5G) Return Loss and VSWR

4.2.2 5G Antennas Isolation

(requirement:5150-5850MHz,Isolation<-20)

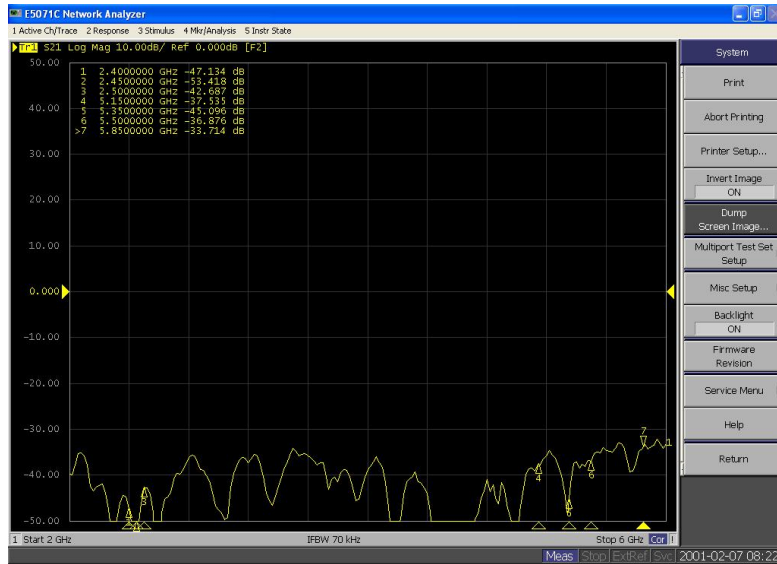

Figure27 Isolation between ANT3 and ANT4

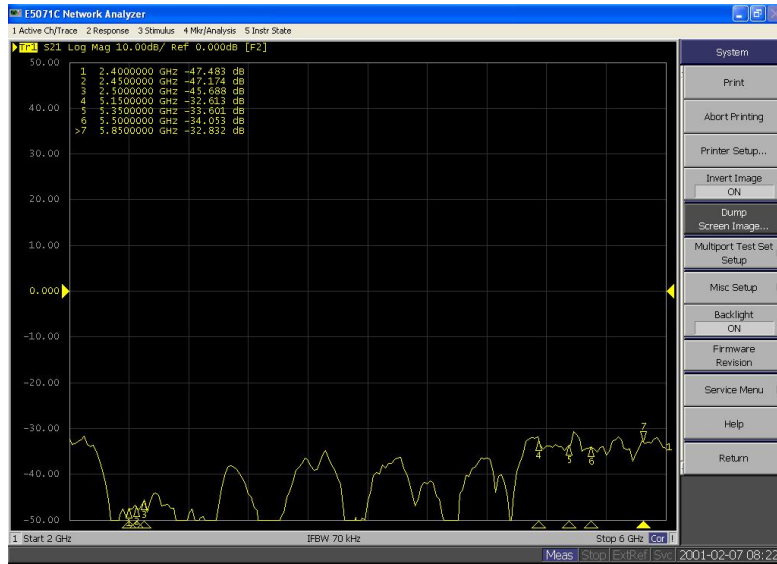

Figure28 Isolation between ANT3 and ANT5

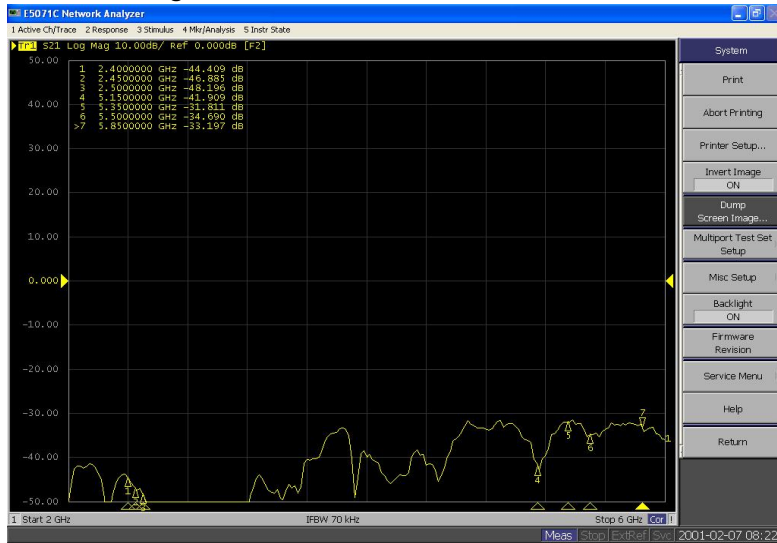

Figure29 Isolation between ANT3 and ANT7

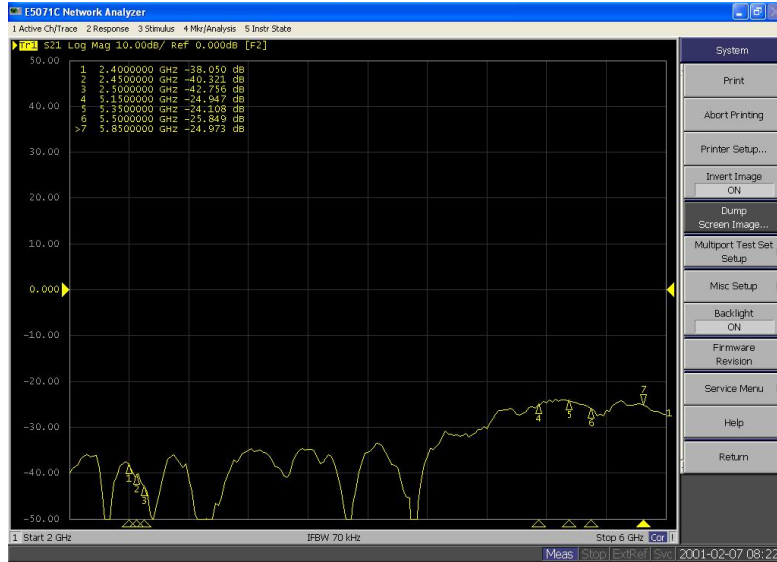

Figure30 Isolation between ANT4and ANT5

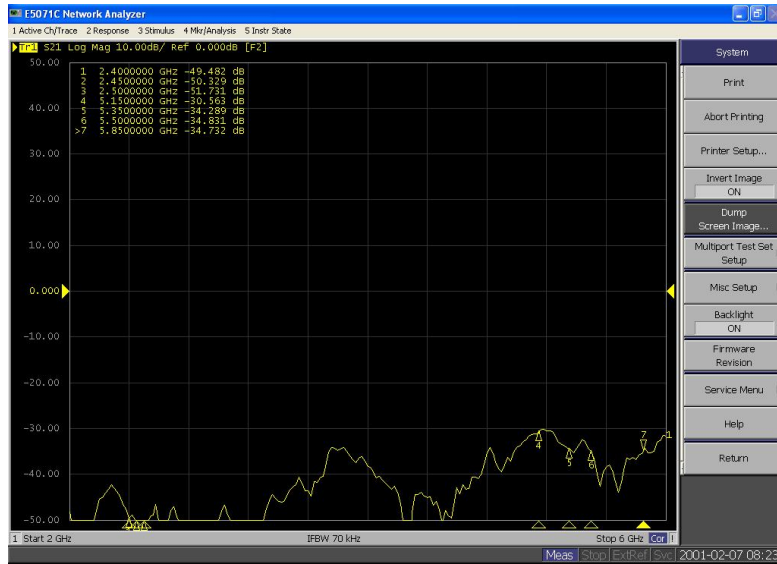

Figure31 Isolation between ANT4and ANT7

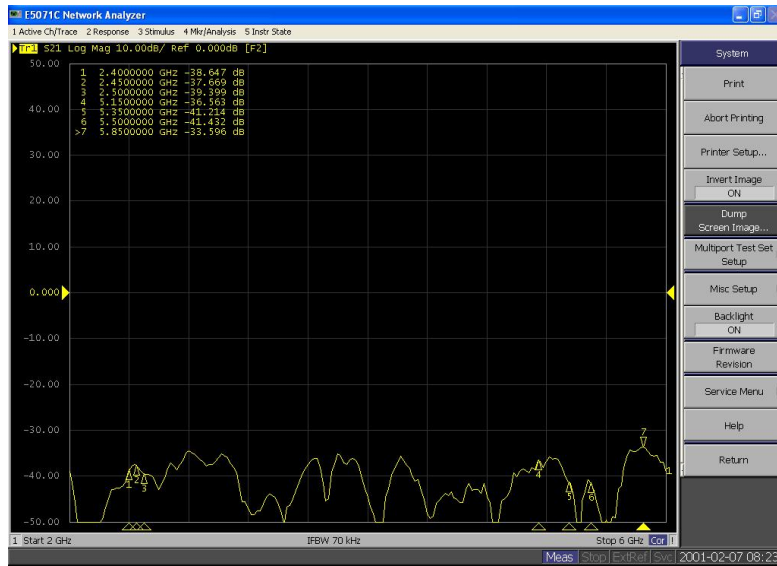

Figure32 Isolation between ANT5 and ANT7

5.Passive Test Results

5.1 2.45GHz Radiation pattern test results

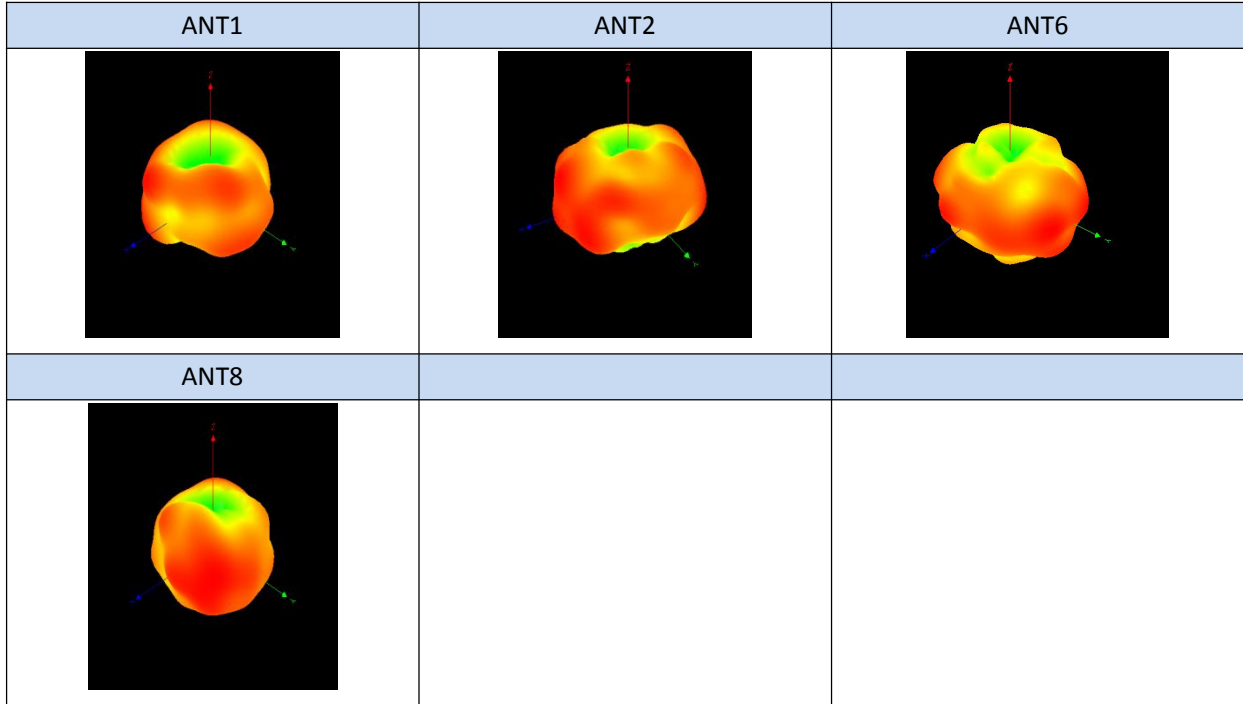
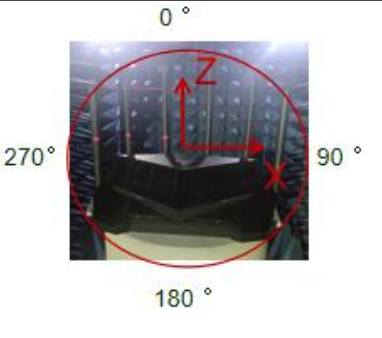
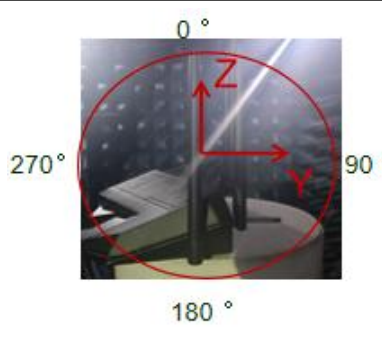
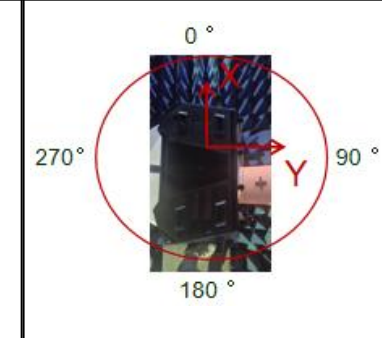
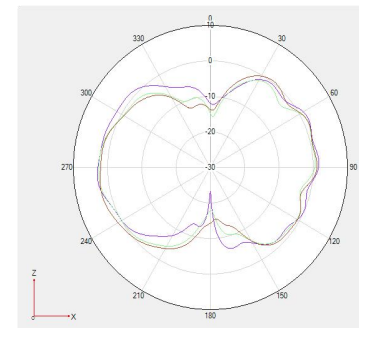
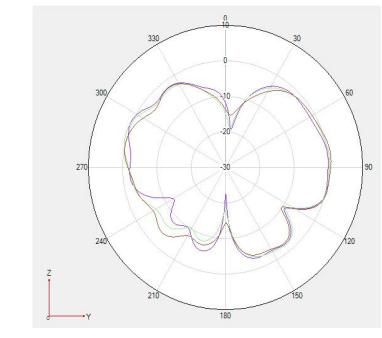
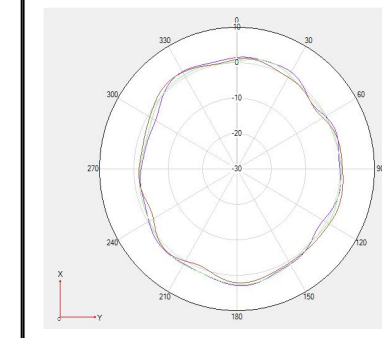
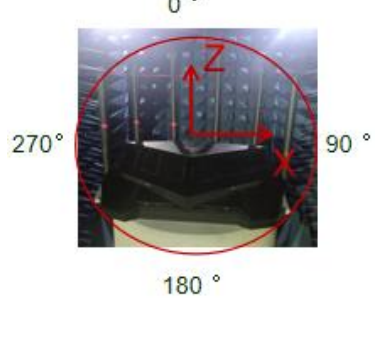
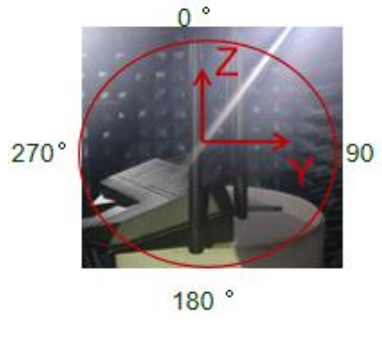
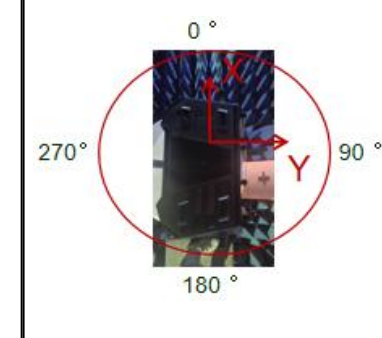
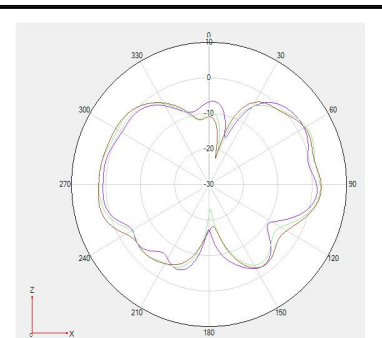
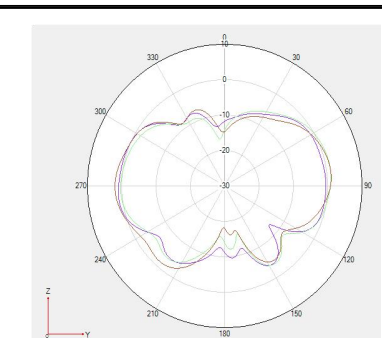
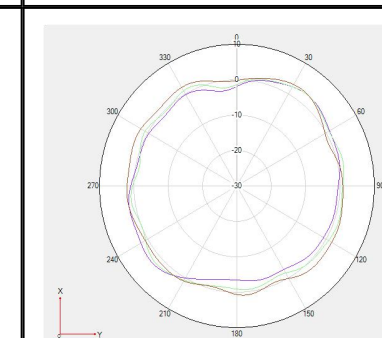

Figure33 2.4G 3D far-field pattern

		Z-X plane(E1)	Z-Y plane(E2)	X-Y plane(horizontal plane)
A N T 1				
A N T 2				

		Z-X plane(E1)	Z-Y plane(E2)	X-Y plane(horizontal plane)
A N T 6				
				
A N T 8				
				

5.2 2.4G Gain and Efficiency

Mark	Frequency(MHz)	Peak gain(dBi)	Efficiency(%)
ANT1	2400	2	66.75
	2450	2	72.09
	2500	2	66.53
ANT2	2400	2	65.41
	2450	2	70.95
	2500	2	71.80
ANT6	2400	2	65.16
	2450	2	66.57
	2500	2	71.66
ANT8	2400	2	70.95
	2450	2	67.30
	2500	2	73.12

Note:

(i) If transmit signals are *correlated*, then

Directional gain = $10 \log[(10^{G_1/20} + 10^{G_2/20} + \dots + 10^{G_N/20})^2 / N_{ANT}]$ dBi [Note the “20”s in the denominator of each exponent and the square of the sum of terms; the object is to combine the signal levels coherently.]

5.3 5.5GHz Radiation pattern test results

ANT3	ANT4	ANT5
		
ANT7		

Figure34 5G 3D far-field pattern

		Z-X plane(E1)	Z-Y plane(E2)	X-Y plane(horizontal plane)
A N T 3				
A N T 4				

		Z-X plane(E1)	Z-Y plane(E2)	X-Y plane(horizontal plane)
A N T 5				
A N T 7				

5.4 5G Gain and Efficiency

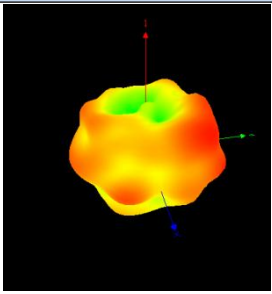
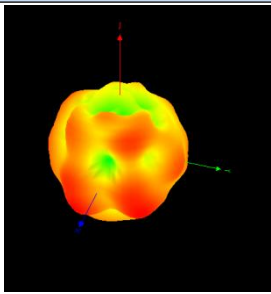
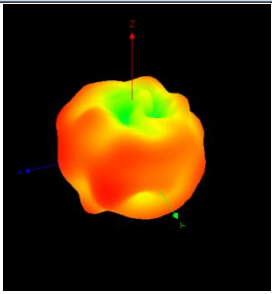
Mark	Frequency(MHz)	Peak gain(dBi)	Efficiency(%)
ANT3	5150	2	65.09
	5500	2	69.30
	5850	2	65.61
ANT4	5150	2	68.23
	5500	2	74.30
	5850	2	71.61
ANT5	5150	2	68.71
	5500	2	75.86
	5850	2	66.68
ANT7	5150	2	65.42
	5500	2	66.99
	5850	2	71.45

Note:

- (i) If transmit signals are *correlated*, then

Directional gain = $10 \log[(10^{G_1/20} + 10^{G_2/20} + \dots + 10^{G_N/20})^2 / N_{ANT}]$ dBi [Note the “20”s in the denominator of each exponent and the square of the sum of terms; the object is to combine the signal levels coherently.]