



SPORTON International Inc.

No. 52, Hwa Ya 1st Rd., Hwa Ya Technology Park, Kwei-Shan Hsiang, Tao Yuan Hsien, Taiwan, R.O.C.
Ph: 886-3-327-3456 / FAX: 886-3-327-0973 / www.sporton.com.tw

FCC RADIO TEST REPORT

Applicant's company	ASUSTeK COMPUTER INC.
Applicant Address	4F, No. 150, Li-Te Rd., Peitou, Taipei 112, Taiwan
FCC ID	MSQ-RTACHC00
Manufacturer's company (1)	ASKEY TECHNOLOGY (JIANG SU) LTD
Manufacturer Address	NO1388, Jiao Tong Road, Wujiang Economic Technological Development Area Jiangsu Province 215200 China
Manufacturer's company (2)	Compal Networking (KunShan) Co., LTD.
Manufacturer Address	No. 520, Nabbang Rd., Economic & Technical Development Zone Kunshan, Jiangsu Province China
Manufacturer's company (3)	Maintek Computer(SUZHOU) Co., LTD
Manufacturer Address	Bldg. 6 NB, 233 Jin Feng Rd, Suzhou District Jiangsu China

Product Name	Wireless-AC1750 Dual Band Gigabit Router, Wireless-AC1900 Dual Band Gigabit Router
Brand Name	ASUS
Model No.	RT-AC66U B1, RT-AC67U/R/W,RT-AC66U V2, RT-AC1750,RT-AC1900, RT-AC1750X (X can be 0-9, A-Z, or blank), RT-AC1900X (X can be 0-9, A-Z, or blank), RT-AC1750_V2, RT-AC1750 V2, RT-AC1750R V2, RT-AC1750W V2, RT-AC1900_V2, RT-AC1900R V2, RT-AC1900_V2, RT-AC1900R_V2
Test Rule Part(s)	47 CFR FCC Part 15 Subpart C § 15.247
Test Freq. Range	2400 ~ 2483.5MHz
Received Date	Jan. 28, 2016
Final Test Date	Jul. 20, 2016
Submission Type	Original Equipment

Statement

Test result included is only for the IEEE 802.11b/g, IEEE 802.11n and IEEE 802.11a/ac of the product.

The test result in this report refers exclusively to the presented test model / sample.

Without written approval of SPORTON International Inc., the test report shall not be reproduced except in full.

The measurements and test results shown in this test report were made in accordance with the procedures and found in compliance with the limit given in **ANSI C63.10-2013, 47 CFR FCC Part 15 Subpart C, KDB558074 D01 v03r05, KDB 662911 D01 v02r01, KDB644545 D01 v01r02.**

The test equipment used to perform the test is calibrated and traceable to NML/ROC.





Table of Contents

1. VERIFICATION OF COMPLIANCE	1
2. SUMMARY OF THE TEST RESULT	2
3. GENERAL INFORMATION	3
3.1. Product Details.....	3
3.2. Accessories.....	4
3.3. Table for Filed Antenna.....	5
3.4. Table for Carrier Frequencies	6
3.5. Table for Test Modes	7
3.6. Table for Testing Locations.....	9
3.7. Table for Multiple List.....	9
3.8. Table for Supporting Units	10
3.9. Table for Parameters of Test Software Setting	11
3.10. EUT Operation during Test	11
3.11. Duty Cycle.....	12
3.12. Test Configurations	13
4. TEST RESULT	16
4.1. AC Power Line Conducted Emissions Measurement.....	16
4.2. Maximum Conducted Output Power Measurement.....	20
4.3. Power Spectral Density Measurement	23
4.4. 6dB Spectrum Bandwidth Measurement	36
4.5. Radiated Emissions Measurement	46
4.6. Emissions Measurement	71
4.7. Antenna Requirements	97
5. LIST OF MEASURING EQUIPMENTS	98
6. MEASUREMENT UNCERTAINTY	100
APPENDIX A. TEST PHOTOS	A1 ~ A4
APPENDIX B. RADIATED EMISSION CO-LOCATION REPORT	B1 ~ B3



History of This Test Report

REPORT NO.	VERSION	DESCRIPTION	ISSUED DATE
FR612512-01AA	Rev. 01	Initial issue of report	Aug. 01, 2016

1. VERIFICATION OF COMPLIANCE

Product Name : Wireless-AC1750 Dual Band Gigabit Router,
Wireless-AC1900 Dual Band Gigabit Router

Brand Name : ASUS

Model No. : RT-AC66U B1, RT-AC67U/R/W,RT-AC66U V2, RT-AC1750,RT-AC1900,
RT-AC1750X (X can be 0-9, A-Z, or blank),
RT-AC1900X (X can be 0-9, A-Z, or blank),
RT-AC1750_V2, RT-AC1750 V2, RT-AC1750R V2, RT-AC1750W V2,
RT-AC1900 V2, RT-AC1900R V2, RT-AC1900_V2, RT-AC1900R_V2

Applicant : ASUSTeK COMPUTER INC.

Test Rule Part(s) : 47 CFR FCC Part 15 Subpart C § 15.247

Sporton International as requested by the applicant to evaluate the EMC performance of the product sample received on Jan. 28, 2016 would like to declare that the tested sample has been evaluated and found to be in compliance with the tested rule parts. The data recorded as well as the test configuration specified is true and accurate for showing the sample's EMC nature.

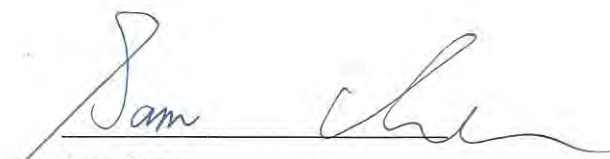

Sam Chen

SPORTON INTERNATIONAL INC.

2. SUMMARY OF THE TEST RESULT

Applied Standard: 47 CFR FCC Part 15 Subpart C			
Part	Rule Section	Description of Test	Result
4.1	15.207	AC Power Line Conducted Emissions	Complies
4.2	15.247(b)(3)	Maximum Conducted Output Power	Complies
4.3	15.247(e)	Power Spectral Density	Complies
4.4	15.247(a)(2)	6dB Spectrum Bandwidth	Complies
4.5	15.247(d)	Radiated Emissions	Complies
4.6	15.247(d)	Band Edge Emissions	Complies
4.7	15.203	Antenna Requirements	Complies

3. GENERAL INFORMATION

3.1. Product Details

Items	Description
Product Type	IEEE 802.11b/g/n/ac: WLAN (3TX, 3RX)
Radio Type	Intentional Transceiver
Power Type	From power adapter
Modulation	IEEE 802.11b: DSSS IEEE 802.11g: OFDM IEEE 802.11n/ac: see the below table
Data Modulation	IEEE 802.11b: DSSS (BPSK / QPSK / CCK) IEEE 802.11g/n: OFDM (BPSK / QPSK / 16QAM / 64QAM) IEEE 802.11ac: OFDM (BPSK / QPSK / 16QAM / 64QAM / 256QAM)
Data Rate (Mbps)	IEEE 802.11b: DSSS (1/ 2/ 5.5/11) IEEE 802.11g: OFDM (6/9/12/18/24/36/48/54) IEEE 802.11n/ac: see the below table
Frequency Range	2400 ~ 2483.5MHz
Channel Number	11 for 20MHz bandwidth ; 7 for 40MHz bandwidth
Channel Band Width (99%)	<p><For non-beamforming mode></p> <p>IEEE 802.11b: 12.07 MHz IEEE 802.11g: 17.28 MHz IEEE 802.11ac MCS0/Nss1 (VHT20): 18.06 MHz IEEE 802.11ac MCS0/NSS1 (VHT40): 36.47 MHz</p> <p><For beamforming mode></p> <p>IEEE 802.11ac MCS0/Nss1 (VHT20): 17.89 MHz IEEE 802.11ac MCS0/NSS1 (VHT40): 36.76 MHz</p>
Maximum Conducted Output Power	<p><For non-beamforming mode></p> <p>IEEE 802.11b: 29.88 dBm IEEE 802.11g: 29.96 dBm IEEE 802.11ac MCS0/Nss1 (VHT20): 29.97 dBm IEEE 802.11ac MCS0/NSS1 (VHT40): 23.05 dBm</p> <p><For beamforming mode></p> <p>IEEE 802.11ac MCS0/Nss1 (VHT20): 28.95 dBm IEEE 802.11ac MCS0/NSS1 (VHT40): 22.68 dBm</p>
Carrier Frequencies	Please refer to section 3.4
Antenna	Please refer to section 3.3

Items	Description	
Beamforming Function	<input checked="" type="checkbox"/> With beamforming	<input type="checkbox"/> Without beamforming

Note: The EUT has Beamforming Function for 802.11n/ac in 2.4GHz and 5GHz.

Antenna and Band width

Antenna	Three (TX)	
Band width Mode	20 MHz	40 MHz
IEEE 802.11b	V	X
IEEE 802.11g	V	X
IEEE 802.11n	V	V
IEEE 802.11ac	V	V

IEEE 802.11n/ac Spec.

Protocol	Number of Transmit Chains (NTX)	Data Rate / MCS
802.11n (HT20)	3	MCS0-23
802.11n (HT40)	3	MCS0-23
802.11ac (VHT20)	3	MCS0-9/Nss1-3
802.11ac (VHT40)	3	MCS0-9/Nss1-3
802.11ac (VHT80)	3	MCS0-9/Nss1-3

Note 1: IEEE Std. 802.11n modulation consists of HT20 and HT40 (HT: High Throughput).

Then EUT supports HT20 and HT40.

Note 2: IEEE Std. 802.11ac modulation consists of VHT20, VHT40 in 2.4GHz (VHT: Very High Throughput).

Then EUT supports VHT20 and VHT40.

Note 3: Modulation modes consist of below configuration:

HT20/HT40: IEEE 802.11n, VHT20/VHT40: IEEE 802.11ac

3.2. Accessories

Power	Brand	Model	Rating
Adapter 1	ASUS	ADP-33AW B	INPUT: 100-240V, 1A, 50-60Hz OUTPUT: 19V, 1.75A
Adapter 2	ASUS	AD890326	INPUT: 100-240V, 0.8A, 50-60Hz OUTPUT: 19V, 1.75A
Others			
RJ-45 cable*1, Non-shielded, 1.5m			

3.3. Table for Filed Antenna

Set	Ant.	Brand	P/N	Antenna Type	Connector	Gain (dBi)	
						2.4GHz	5GHz
1	1	PSA	RFDPA181313IMLB701	Dipole Antenna	I-PEX	1.85	3.14
	2	PSA	RFDPA181306IMLB701	Dipole Antenna	I-PEX	1.83	2.70
	3	PSA	RFDPA181306IMLB702	Dipole Antenna	I-PEX	2.22	3.28
2	4	M.gear	C660-510379-A (SRF20161063)	Dipole Antenna	I-PEX	1.61	2.34
	5	M.gear	C660-510380-A (SRF20161064)	Dipole Antenna	I-PEX	1.69	2.52
	6	M.gear	C660-510381-A (SRF20161065)	Dipole Antenna	I-PEX	1.69	2.52

Note: The EUT has two sets of antenna and there are three antennas for each set.

Because Set 1 and Set 2 are the same type antennas, only the higher gain antenna "Set 1" was tested.

For IEEE 802.11a/b/g/n/ac mode (3TX/3RX):

Chain 1, Chain 2 and Chain 3 can be used as transmitting/receiving antenna.

Chain 1, Chain 2 and Chain 3 could transmit/receive simultaneously.

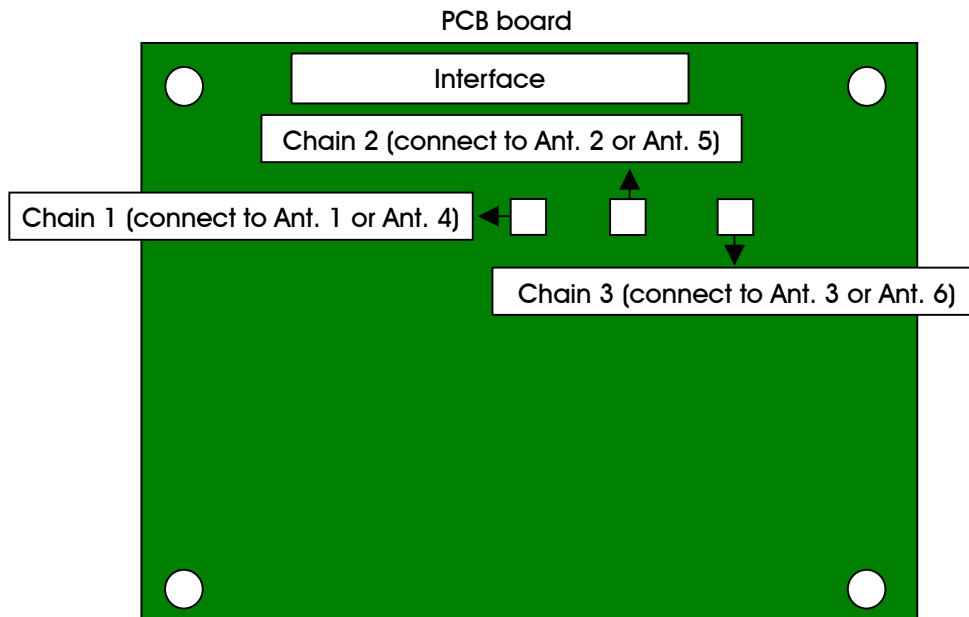

3.4. Table for Carrier Frequencies

There are two bandwidth systems.

For 20MHz bandwidth systems, use Channel 1~Channel 11.

For 40MHz bandwidth systems, use Channel 3~Channel 9.

Frequency Band	Channel No.	Frequency	Channel No.	Frequency
2400~2483.5MHz	1	2412 MHz	7	2442 MHz
	2	2417 MHz	8	2447 MHz
	3	2422 MHz	9	2452 MHz
	4	2427 MHz	10	2457 MHz
	5	2432 MHz	11	2462 MHz
	6	2437 MHz	-	-

3.5. Table for Test Modes

Preliminary tests were performed in different data rate to find the worst radiated emission. The data rate shown in the table below is the worst-case rate with respect to the specific test item. Investigation has been done on all the possible configurations for searching the worst cases. The following table is a list of the test modes shown in this test report.

Test Items	Mode	Data Rate	Channel	Chain
AC Power Line Conducted Emissions	CTX	-	-	-
Maximum Conducted Output Power	<For non-beamforming mode>			
	11b/CCK	1 Mbps	1/6/11	1+2+3
	11g/BPSK	6 Mbps	1/6/11	1+2+3
	11ac VHT20	MCS0/Nss1	1/6/11	1+2+3
	11ac VHT40	MCS0/NSS1	3/6/9	1+2+3
	<For beamforming mode>			
	11ac VHT20	MCS0/Nss1	1/6/11	1+2+3
	11ac VHT40	MCS0/NSS1	3/6/9	1+2+3
Power Spectral Density	<For non-beamforming mode>			
	11b/CCK	1 Mbps	1/6/11	1+2+3
	11g/BPSK	6 Mbps	1/6/11	1+2+3
	11ac VHT20	MCS0/Nss1	1/6/11	1+2+3
	11ac VHT40	MCS0/NSS1	3/6/9	1+2+3
	<For beamforming mode>			
	11ac VHT20	MCS0/Nss1	1/6/11	1+2+3
	11ac VHT40	MCS0/NSS1	3/6/9	1+2+3
6dB Spectrum Bandwidth	<For non-beamforming mode>			
	11b/CCK	1 Mbps	1/6/11	1+2+3
	11g/BPSK	6 Mbps	1/6/11	1+2+3
	11ac VHT20	MCS0/Nss1	1/6/11	1+2+3
	11ac VHT40	MCS0/NSS1	3/6/9	1+2+3
	<For beamforming mode>			
	11ac VHT20	MCS0/Nss1	1/6/11	1+2+3
	11ac VHT40	MCS0/NSS1	3/6/9	1+2+3
Radiated Emissions Below 1GHz	CTX	-	-	-
Radiated Emissions Above 1GHz	<For non-beamforming mode>			
	11b/CCK	1 Mbps	1/6/11	1+2+3
	11g/BPSK	6 Mbps	1/6/11	1+2+3
	11ac VHT20	MCS0/Nss1	1/6/11	1+2+3
	11ac VHT40	MCS0/NSS1	3/6/9	1+2+3

	<For beamforming mode>			
	11ac VHT20	MCS0/Nss1	1/6/11	1+2+3
	11ac VHT40	MCS0/NSS1	3/6/9	1+2+3
Band Edge Emissions	<For non-beamforming mode>			
	11b/CCK	1 Mbps	1/6/11	1+2+3
	11g/BPSK	6 Mbps	1/6/11	1+2+3
	11ac VHT20	MCS0/Nss1	1/6/11	1+2+3
	11ac VHT40	MCS0/NSS1	3/6/9	1+2+3
	<For beamforming mode>			
	11ac VHT20	MCS0/Nss1	1/6/11	1+2+3
	11ac VHT40	MCS0/NSS1	3/6/9	1+2+3

Note: 1.VHT20/VHT40 covers HT20/HT40, due to same modulation. The power setting for 802.11n HT20 and HT40 are the same or lower than 802.11ac VHT20 and VHT40.

2. There are two modes of EUT, one is beamforming mode, and the other is non-beamforming mode for 802.11n/ac. All test results were recorded in the report.

3. According to the client's request, the EUT were tested in Z-axis.

The following test modes were performed for all tests:

For Conducted Emission test:

Mode 1. CTX - EUT in Z-axis_2.4G + Adapter 1

Mode 2. CTX - EUT in Z-axis_5G + Adapter 1

Mode 2 has been evaluated to be the worst case among Mode 1~2, thus measurement for Mode 3 will follow this same test mode.

Mode 3. CTX - EUT in Z-axis_2.4G + Adapter 2

Mode 3 is the worst case, so it was selected to record in this test report.

For Radiated Emission below 1GHz test:

Mode 1. CTX - EUT in Z-axis_2.4G + Adapter 1

Mode 2. CTX - EUT in Z-axis_5G + Adapter 1

Mode 2 has been evaluated to be the worst case among Mode 1~2, thus measurement for Mode 3 will follow this same test mode.

Mode 3. CTX - EUT in Z-axis_5G + Adapter 2

Mode 2 is the worst case, so it was selected to record in this test report.

For Radiated Emission above 1GHz test:

Mode 1. CTX - EUT in Z-axis

For Co-location MPE and Radiated Emission Co-location Test:

The EUT could be applied with 2.4GHz WLAN function and 5GHz WLAN function; therefore Co-location Maximum Permissible Exposure (Please refer to FA612512-01) and Radiated Emission Co-location (please refer to Appendix B) tests are added for simultaneously transmit between 2.4GHz WLAN function and 5GHz WLAN function.

3.6. Table for Testing Locations

Test Site Location				
Address:	No.8, Lane 724, Bo-ai St., Jhubei City, Hsinchu County 302, Taiwan, R.O.C.			
TEL:	886-3-656-9065			
FAX:	886-3-656-9085			
Test Site No.	Site Category	Location	FCC Designation No.	IC File No.
03CH01-CB	SAC	Hsin Chu	TW0006	IC 4086D
CO01-CB	Conduction	Hsin Chu	TW0006	IC 4086D
TH01-CB	OVEN Room	Hsin Chu	-	-

Open Area Test Site (OATS); Semi Anechoic Chamber (SAC).

3.7. Table for Multiple List

Brand Name	Equipment Name	Model Name
ASUS	Wireless-AC1750 Dual Band Gigabit Router,	RT-AC66U B1
		RT-AC67U/R/W
		RT-AC66U V2
		RT-AC1750
		RT-AC1900,
		RT-AC1750X (X can be 0-9, A-Z, or blank)
		RT-AC1900X (X can be 0-9, A-Z, or blank)
	Wireless-AC1900 Dual Band Gigabit Router	RT-AC1750_V2
		RT-AC1750 V2
		RT-AC1750R V2
		RT-AC1750W V2
		RT-AC1900 V2
		RT-AC1900R V2
		RT-AC1900_V2
	RT-AC1900R_V2	
Description		
All the models are identical, the difference model for difference brand served as marketing strategy.		

From the above models, model: RT-AC66U B1 was selected as representative model for the test and its data was recorded in this report.

3.8. Table for Supporting Units

For Test Site No: CO01-CB

Support Unit	Brand	Model	FCC ID
Notebook	DELL	E6430	DoC
Flash disk	Silicon	I-Series	DoC
Flash disk3.0	Transcend	JetFlash-700	DoC

For Test Site No: TH01-CB

Support Unit	Brand	Model	FCC ID
Notebook	DELL	E4300	DoC

For Test Site No: 03CH01-CB (For below 1GHz)

Support Unit	Brand	Model	FCC ID
Notebook	DELL	E4300	DoC

For Test Site No: 03CH01-CB (For above 1GHz)

<For non-beamforming mode>

Support Unit	Brand	Model	FCC ID
Notebook	DELL	E4300	DoC

<For beamforming mode>

Support Unit	Brand	Model	FCC ID
Notebook*2	DELL	E4300	DoC
WLAN ac Dongle	Broadcom	Bcm4366	DoC

3.9. Table for Parameters of Test Software Setting

During testing, Channel and Power Controlling Software provided by the customer was used to control the operating channel as well as the output power level. The RF output power selection is for the setting of RF output power expected by the customer and is going to be fixed on the firmware of the final end product.

<For non-beamforming mode>

Test Software Version	Mtool 2.0.2.7					
Mode	Test Frequency (MHz)					
	NCB: 20MHz			NCB: 40MHz		
	2412 MHz	2437 MHz	2462 MHz	2422 MHz	2437 MHz	2452 MHz
802.11b	104	104	104	-	-	-
802.11g	81	103	80	-	-	-
802.11ac MCS0/Nss1 VHT20	81	103	79	-	-	-
802.11ac MCS0/NSS1 VHT40	-	-	-	69	79	63

<For beamforming mode>

Test Software Version	Mtool 2.0.2.7					
Mode	Test Frequency (MHz)					
	NCB: 20MHz			NCB: 40MHz		
	2412 MHz	2437 MHz	2462 MHz	2422 MHz	2437 MHz	2452 MHz
802.11ac MCS0/Nss1 VHT20	64	97	66	-	-	-
802.11ac MCS0/NSS1 VHT40	-	-	-	63	76	63

3.10. EUT Operation during Test

For non-beamforming mode:

The EUT was programmed to be in continuously transmitting mode.

For beamforming mode:

For Conducted Mode:

The EUT was programmed to be in continuously transmitting mode.

For Radiated Mode:

During the test, the following programs under WIN 7 were executed.

The program was executed as follows:

1. During the test, the EUT operation to normal function.
2. Executed command fixed test channel under Telnet.
3. Executed "Lantest.exe " to link with the remote workstation to receive and transmit packet by WLAN ac dongle and transmit duty cycle no less 98%

3.11. Duty Cycle

For non-beamforming mode:

Mode	On Time (ms)	On+Off Time (ms)	Duty Cycle (%)	Duty Factor (dB)	1/T Minimum VBW (kHz)
802.11b	1.000	1.000	100	0.00	0.01
802.11g	2.070	2.090	99.04	0.04	0.01
802.11ac MCS0/Nss1 VHT20	1.899	1.931	98.34	0.07	0.01
802.11ac MCS0/NSS1 VHT40	0.918	0.975	94.15	0.26	1.09

For beamforming mode:

Mode	On Time (ms)	On+Off Time (ms)	Duty Cycle (%)	Duty Factor (dB)	1/T Minimum VBW (kHz)
802.11ac MCS0/Nss1 VHT20	3.813	4.154	91.79	0.37	0.26
802.11ac MCS0/NSS1 VHT40	4.995	5.373	92.96	0.32	0.20

3.12. Test Configurations

3.12.1. AC Power Line Conduction Emissions Test Configuration

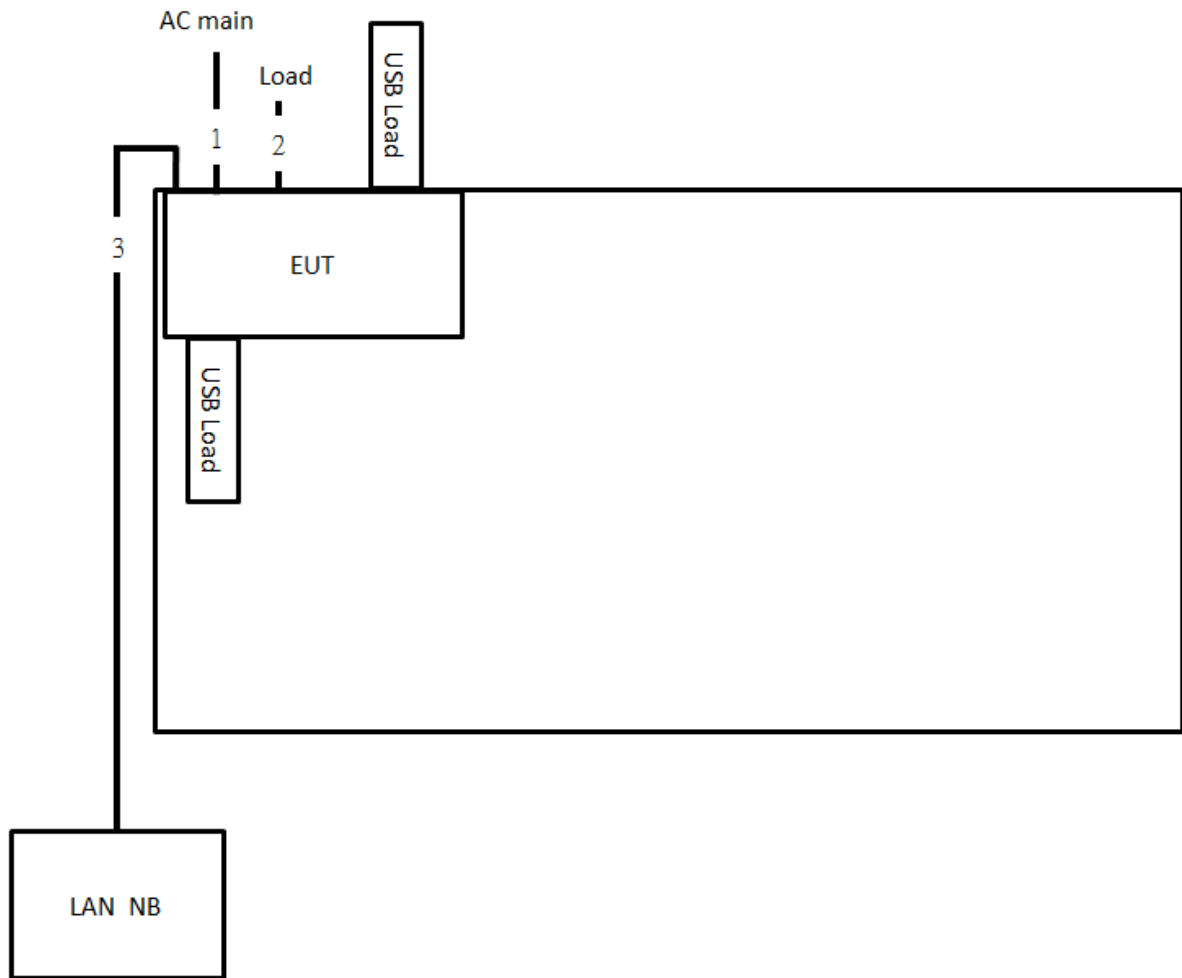

Item	Connection	Shielded	Length
1	Power cable	No	2.2m
2	RJ-45 cable*4	No	1.5m
3	RJ-45 cable	No	10m

3.12.2. Radiation Emissions Test Configuration

Test Configuration: 30MHz~1GHz and above 1GHz <For non-beamforming mode>

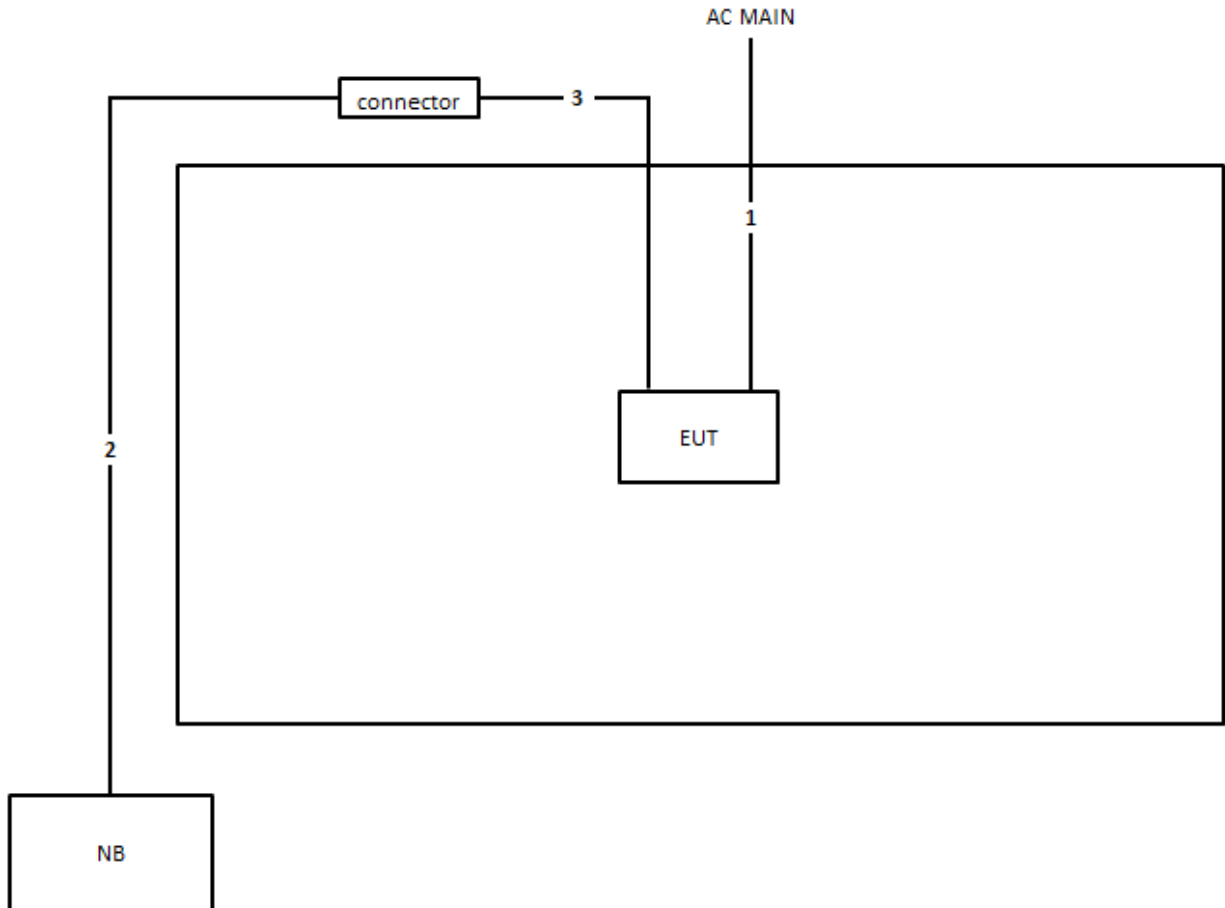

Item	Connection	Shielded	Length
1	Power cable	No	2.2m
2	RJ-45 cable	No	10m
3	RJ-45 cable	No	1.5m

Test Configuration: above 1GHz <For beamforming mode>

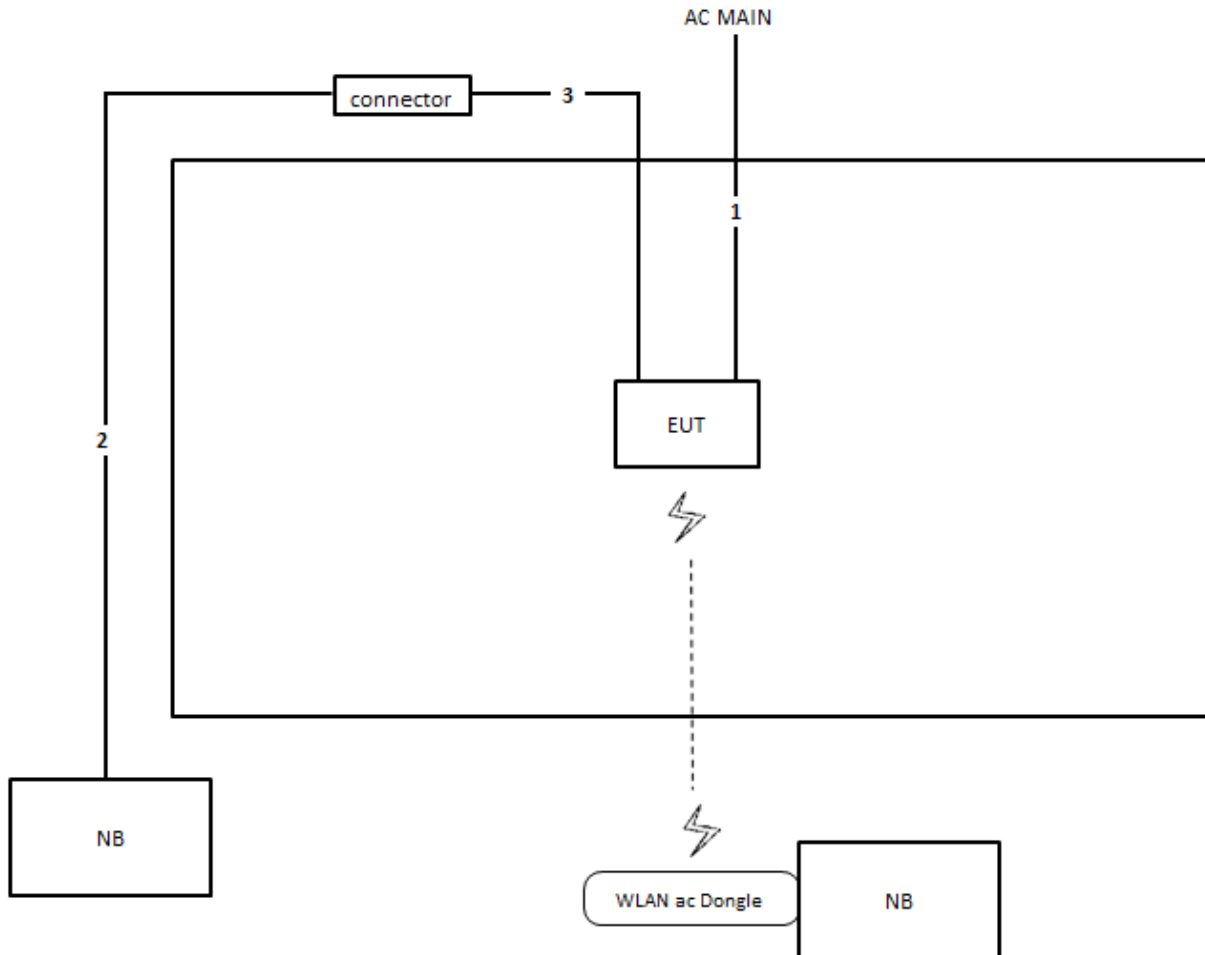

Item	Connection	Shielded	Length
1	Power cable	No	2.2m
2	RJ-45 cable	No	10m
3	RJ-45 cable	No	1.5m

4. TEST RESULT

4.1. AC Power Line Conducted Emissions Measurement

4.1.1. Limit

For this product which is designed to be connected to the AC power line, the radio frequency voltage that is conducted back onto the AC power line on any frequency or frequencies within the band 150 kHz to 30 MHz shall not exceed below limits table.

Frequency (MHz)	QP Limit (dBuV)	AV Limit (dBuV)
0.15~0.5	66~56	56~46
0.5~5	56	46
5~30	60	50

4.1.2. Measuring Instruments and Setting

Please refer to section 5 of equipments list in this report. The following table is the setting of the receiver.

Receiver Parameters	Setting
Attenuation	10 dB
Start Frequency	0.15 MHz
Stop Frequency	30 MHz
IF Bandwidth	9 kHz

4.1.3. Test Procedures

1. Configure the EUT according to ANSI C63.10. The EUT or host of EUT has to be placed 0.4 meter far from the conducting wall of the shielding room and at least 80 centimeters from any other grounded conducting surface.
2. Connect EUT or host of EUT to the power mains through a line impedance stabilization network (LISN).
3. All the support units are connected to the other LISNs. The LISN should provide 50uH/50ohms coupling impedance.
4. The frequency range from 150 kHz to 30 MHz was searched.
5. Set the test-receiver system to Peak Detect Function and Specified Bandwidth with Maximum Hold Mode.
6. The measurement has to be done between each power line and ground at the power terminal.

4.1.4. Test Setup Layout

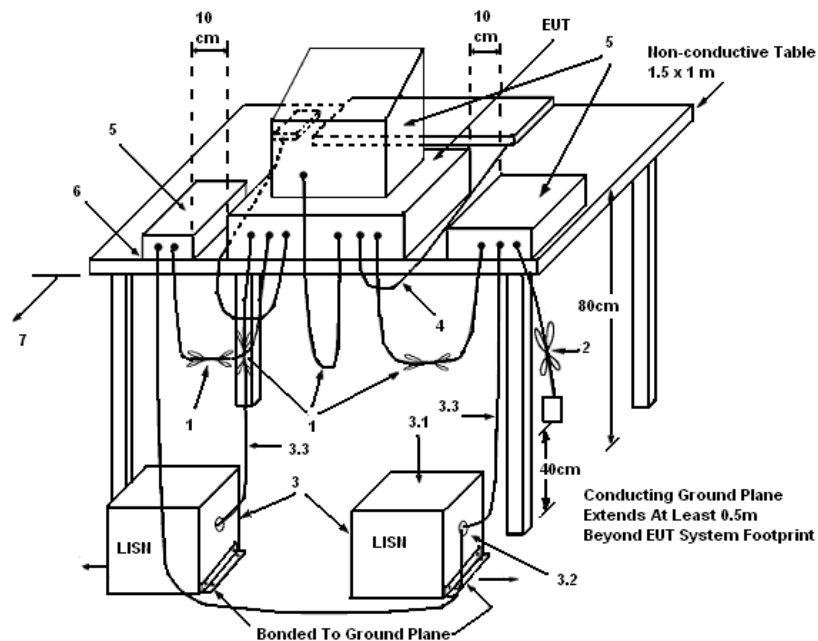

LEGEND:

- (1) Interconnecting cables that hang closer than 40 cm to the ground plane shall be folded back and forth in the center forming a bundle 30 to 40 cm long.
- (2) I/O cables that are not connected to a peripheral shall be bundled in the center. The end of the cable may be terminated, if required, using the correct terminating impedance. The overall length shall not exceed 1 m.
- (3) EUT connected to one LISN. Unused LISN measuring port connectors shall be terminated in 50 Ω . LISN can be placed on top of, or immediately beneath, reference ground plane.
 - (3.1) All other equipment powered from additional LISN(s).
 - (3.2) Multiple outlet strip can be used for multiple power cords of non-EUT equipment.
 - (3.3) LISN at least 80 cm from nearest part of EUT chassis.
- (4) Cables of hand-operated devices, such as keyboards, mice, etc., shall be placed as for normal use.
- (5) Non-EUT components of EUT system being tested.
- (6) Rear of EUT, including peripherals, shall all be aligned and flush with rear of tabletop.
- (7) Rear of tabletop shall be 40 cm removed from a vertical conducting plane that is bonded to the ground plane.

4.1.5. Test Deviation

There is no deviation with the original standard.

4.1.6. EUT Operation during Test

The EUT was placed on the test table and programmed in normal function.

4.1.7. Results of AC Power Line Conducted Emissions Measurement

Temperature	20°C	Humidity	56%
Test Engineer	Deven Huang	Phase	Line
Configuration	CTX	Test Mode	Mode 3

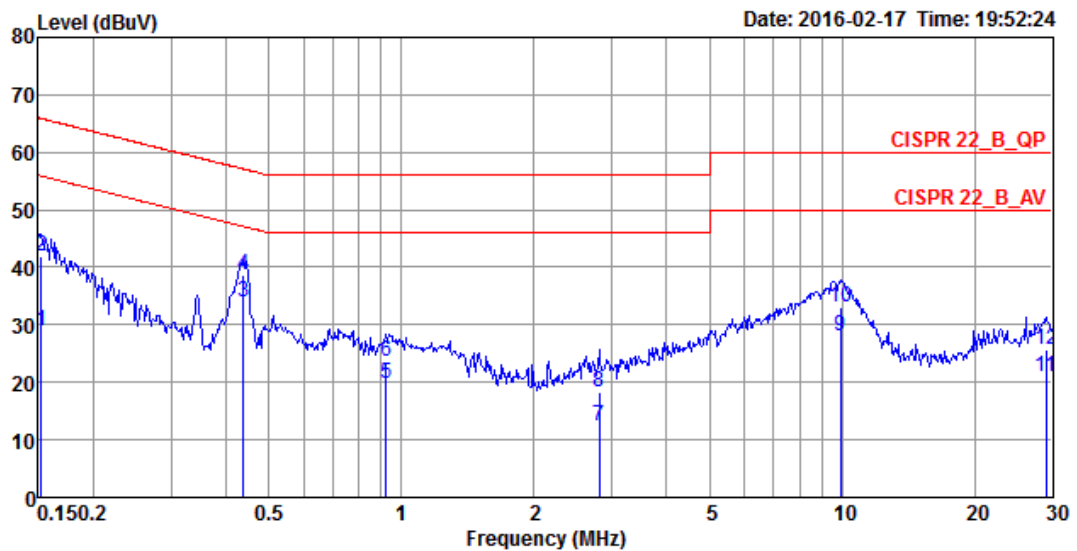

	Freq	Level	Over Limit	Limit Line	Read Level	LISN Factor	Cable Loss	Pol/Phase	Remark
	MHz	dBuV	dB	dBuV	dBuV	dB	dB		
1	0.1524	29.01	-26.86	55.87	19.06	9.93	0.02	LINE	Average
2	0.1524	42.04	-23.83	65.87	32.09	9.93	0.02	LINE	QP
3	0.4374	34.04	-13.07	47.11	24.07	9.93	0.04	LINE	Average
4	0.4374	38.77	-18.34	57.11	28.80	9.93	0.04	LINE	QP
5	0.9233	19.92	-26.08	46.00	9.91	9.96	0.05	LINE	Average
6	0.9233	23.66	-32.34	56.00	13.65	9.96	0.05	LINE	QP
7	2.8091	12.30	-33.70	46.00	2.25	10.00	0.05	LINE	Average
8	2.8091	18.27	-37.73	56.00	8.22	10.00	0.05	LINE	QP
9	9.9130	28.10	-21.90	50.00	17.67	10.18	0.25	LINE	Average
10	9.9130	33.03	-26.97	60.00	22.60	10.18	0.25	LINE	QP
11	29.0613	21.03	-28.97	50.00	10.09	10.66	0.28	LINE	Average
12	29.0613	25.77	-34.23	60.00	14.83	10.66	0.28	LINE	QP

Temperature	20°C	Humidity	56%
Test Engineer	Deven Huang	Phase	Neutral
Configuration	CTX	Test Mode	Mode 3

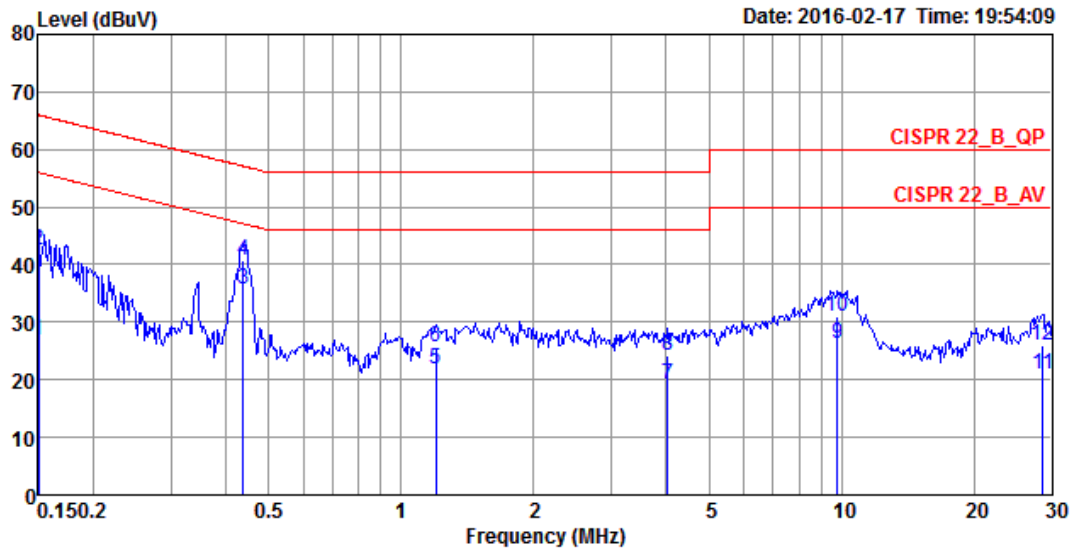

	Freq	Level	Over Limit	Limit Line	Read Level	LISN Factor	Cable Loss	Pol/Phase	Remark
	MHz	dBuV	dB	dBuV	dBuV	dB	dB		
1	0.1500	26.90	-29.10	56.00	17.10	9.78	0.02	NEUTRAL	Average
2	0.1500	42.41	-23.59	66.00	32.61	9.78	0.02	NEUTRAL	QP
3	0.4374	35.63	-11.48	47.11	25.80	9.79	0.04	NEUTRAL	Average
4	0.4374	40.72	-16.39	57.11	30.89	9.79	0.04	NEUTRAL	QP
5	1.1970	21.73	-24.27	46.00	11.86	9.82	0.05	NEUTRAL	Average
6	1.1970	25.68	-30.32	56.00	15.81	9.82	0.05	NEUTRAL	QP
7	4.0275	19.19	-26.81	46.00	9.25	9.87	0.07	NEUTRAL	Average
8	4.0275	24.06	-31.94	56.00	14.12	9.87	0.07	NEUTRAL	QP
9	9.8085	26.14	-23.86	50.00	15.88	10.01	0.25	NEUTRAL	Average
10	9.8085	31.06	-28.94	60.00	20.80	10.01	0.25	NEUTRAL	QP
11	28.6030	20.97	-29.03	50.00	10.36	10.33	0.28	NEUTRAL	Average
12	28.6030	25.87	-34.13	60.00	15.26	10.33	0.28	NEUTRAL	QP

Note:

Level = Read Level + LISN Factor + Cable Loss

4.2. Maximum Conducted Output Power Measurement

4.2.1. Limit

The limit for output power is 30dBm.

4.2.2. Measuring Instruments and Setting

Please refer to section 5 of equipments list in this report. The following table is the setting of the power meter.

Power Meter Parameter	Setting
Detector	Average

4.2.3. Test Procedures

1. Test procedures refer KDB558074 D01 v03r05 section 9.2.3.2 Measurement using a power meter (PM).
2. Multiple antenna system was performed in accordance with KDB 662911 D01 v02r01 Emissions Testing of Transmitters with Multiple Outputs in the Same Band.
3. This procedure provides an alternative for determining the RMS output power using a broadband RF average power meter with a thermocouple detector.

4.2.4. Test Setup Layout

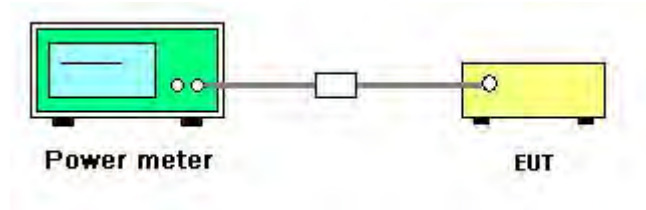

4.2.5. Test Deviation

There is no deviation with the original standard.

4.2.6. EUT Operation during Test

The EUT was programmed to be in continuously transmitting mode.

4.2.7. Test Result of Maximum Conducted Output Power

Temperature	25°C	Humidity	65%
Test Engineer	Andy Tsai	Test Date	May 03, 2016 ~ Jul. 16, 2016
Test Function	For non-beamforming mode		

Mode	Frequency	Conducted Power (dBm)				Max. Limit (dBm)	Result
		Chain 1	Chain 2	Chain 3	Total		
802.11b	2412 MHz	24.67	24.99	25.59	29.87	30.00	Complies
	2437 MHz	24.62	25.03	25.42	29.81	30.00	Complies
	2462 MHz	24.83	25.18	25.29	29.88	30.00	Complies
802.11g	2412 MHz	19.52	19.61	20.33	24.61	30.00	Complies
	2437 MHz	24.72	25.19	25.62	29.96	30.00	Complies
	2462 MHz	19.41	19.76	20.17	24.56	30.00	Complies
802.11ac MCS0/Nss1 VHT20	2412 MHz	19.38	19.35	20.32	24.48	30.00	Complies
	2437 MHz	24.82	25.22	25.52	29.97	30.00	Complies
	2462 MHz	19.16	19.18	19.85	24.18	30.00	Complies
802.11ac MCS0/NSS1 VHT40	2422 MHz	15.45	15.89	16.52	20.75	30.00	Complies
	2437 MHz	17.56	18.35	18.82	23.05	30.00	Complies
	2452 MHz	14.20	14.36	15.26	19.40	30.00	Complies

Temperature	25°C	Humidity	65%
Test Engineer	Andy Tsai	Test Date	Apr. 19, 2016 ~ May 05, 2016
Test Function	For beamforming mode		

Mode	Frequency	Conducted Power (dBm)				Max. Limit (dBm)	Result
		Chain 1	Chain 2	Chain 3	Total		
802.11ac	2412 MHz	16.52	16.09	16.64	21.19	29.26	Complies
MCS0/Nss1	2437 MHz	24.35	24.06	24.12	28.95	29.26	Complies
VHT20	2462 MHz	17.05	16.32	17.36	21.70	29.26	Complies
802.11ac	2422 MHz	14.93	14.66	15.58	19.85	29.26	Complies
MCS0/NSS1	2437 MHz	17.93	17.61	18.18	22.68	29.26	Complies
VHT40	2452 MHz	14.20	14.36	15.26	19.40	29.26	Complies

Note: $DirectionalGain = 10 \cdot \log \left[\frac{\sum_{j=1}^{N_{SS}} \left\{ \sum_{k=1}^{N_{ANT}} g_{j,k} \right\}^2}{N_{ANT}} \right] = 6.74\text{dBi}$, so limit = $30 - (6.74 - 6) = 29.26\text{dBm}$.

4.3. Power Spectral Density Measurement

4.3.1. Limit

For digitally modulated systems, the power spectral density conducted from the intentional radiator to the antenna shall not be greater than 8dBm in any 3 kHz band during any time interval of continuous transmission.

4.3.2. Measuring Instruments and Setting

Please refer to section 5 of equipments list in this report. The following table is the setting of the spectrum analyzer.

Spectrum Parameter	Setting
Attenuation	Auto
Span Frequency	Set the span to 1.5 times the DTS channel bandwidth.
RBW	$3 \text{ kHz} \leq \text{RBW} \leq 100\text{kHz}$
VBW	$\geq 3 \times \text{RBW}$
Detector	Peak
Trace	Max Hold
Sweep Time	Auto couple

4.3.3. Test Procedures

1. Test was performed in accordance with KDB558074 D01 v03r05 for Performing Compliance Measurements on Digital Transmission Systems (DTS) - section 10.2 Method PKPSD (peak PSD) and KDB 662911 D01 v02r01 section In-Band Power Spectral Density (PSD) Measurements option (b) Measure and sum spectral maximal across the outputs.
2. Use this procedure when the maximum conducted output power in the fundamental emission is used to demonstrate compliance. The EUT must be configured to transmit continuously at full power over the measurement duration.
3. Ensure that the number of measurement points in the sweep $\geq 2 \times \text{span}/\text{RBW}$ (use of a greater number of measurement points than this minimum requirement is recommended).
4. Use the peak marker function to determine the maximum level in any 3 kHz band segment within the fundamental EBW.
5. The resulting PSD level must be $\leq 8 \text{ dBm}$.

4.3.4. Test Setup Layout

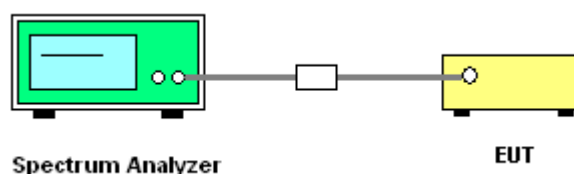

4.3.5. Test Deviation

There is no deviation with the original standard.

4.3.6. EUT Operation during Test

The EUT was programmed to be in continuously transmitting mode.

4.3.7. Test Result of Power Spectral Density

Temperature	25°C	Humidity	65%
Test Engineer	Andy Tsai		
Test Function	For non-beamforming mode		

Mode	Frequency	Power Density (dBm/3kHz)				Power Density Limit (dBm/3kHz)	Result
		Chain 1	Chain 2	Chain 3	Total		
802.11b	2412 MHz	-7.23	-7.25	-7.01	-2.39	7.26	Complies
	2437 MHz	-7.04	-7.30	-7.17	-2.40	7.26	Complies
	2462 MHz	-6.55	-6.72	-6.91	-1.95	7.26	Complies
802.11g	2412 MHz	-5.21	-4.87	-4.85	-0.20	7.26	Complies
	2437 MHz	-0.09	-0.54	0.64	4.80	7.26	Complies
	2462 MHz	-5.12	-5.28	-5.94	-0.66	7.26	Complies
802.11ac MCS0/Nss1 VHT20	2412 MHz	-5.26	-3.74	-5.19	0.10	7.26	Complies
	2437 MHz	-0.18	0.33	0.64	5.05	7.26	Complies
	2462 MHz	-4.51	-5.98	-5.56	-0.53	7.26	Complies
802.11ac MCS0/NSS1 VHT40	2422 MHz	-11.09	-11.02	-11.31	-6.37	7.26	Complies
	2437 MHz	-9.10	-9.06	-9.76	-4.52	7.26	Complies
	2452 MHz	-11.97	-12.63	-13.02	-7.75	7.26	Complies

Note: $DirectionalGain = 10 \cdot \log \left[\frac{\sum_{j=1}^{N_{SS}} \left\{ \sum_{k=1}^{N_{ANT}} g_{j,k} \right\}^2}{N_{ANT}} \right] = 6.74\text{dBi}$, so limit = $8 - (6.74 - 6) = 7.26\text{dBm}$.

Temperature	25°C	Humidity	65%
Test Engineer	Andy Tsai		
Test Function	For beamforming mode		

Mode	Frequency	Power Density (dBm/3kHz)				Power Density Limit (dBm/3kHz)	Result
		Chain 1	Chain 2	Chain 3	Total		
802.11ac	2412 MHz	-9.40	-10.11	-10.37	-5.17	7.26	Complies
MCS0/Nss1	2437 MHz	-1.11	-1.46	-2.08	3.24	7.26	Complies
VHT20	2462 MHz	-10.32	-8.67	-8.52	-4.33	7.26	Complies
802.11ac	2422 MHz	-12.68	-14.32	-13.90	-8.81	7.26	Complies
MCS0/NSS1	2437 MHz	-11.97	-11.46	-11.23	-6.77	7.26	Complies
VHT40	2452 MHz	-12.08	-13.89	-11.93	-7.78	7.26	Complies

Note: $DirectionalGain = 10 \cdot \log \left[\frac{\sum_{j=1}^{N_{SS}} \left\{ \sum_{k=1}^{N_{ANT}} g_{j,k} \right\}^2}{N_{ANT}} \right] = 6.74\text{dBi}$, so limit = $8 - (6.74 - 6) = 7.26\text{dBm}$.

Note: All the test values were listed in the report.

For plots, only the channel with worse result was shown.

<For non-beamforming mode>

Power Density Plot on Configuration IEEE 802.11b / 2462 MHz / Chain 1



Date: 3.MAY.2016 11:20:51

Power Density Plot on Configuration IEEE 802.11b / 2462 MHz / Chain 2



Date: 3.MAY.2016 11:21:01

Power Density Plot on Configuration IEEE 802.11b / 2462 MHz / Chain 3



Date: 3.MAY.2016 11:21:16

Power Density Plot on Configuration IEEE 802.11g / 2437 MHz / Chain 1

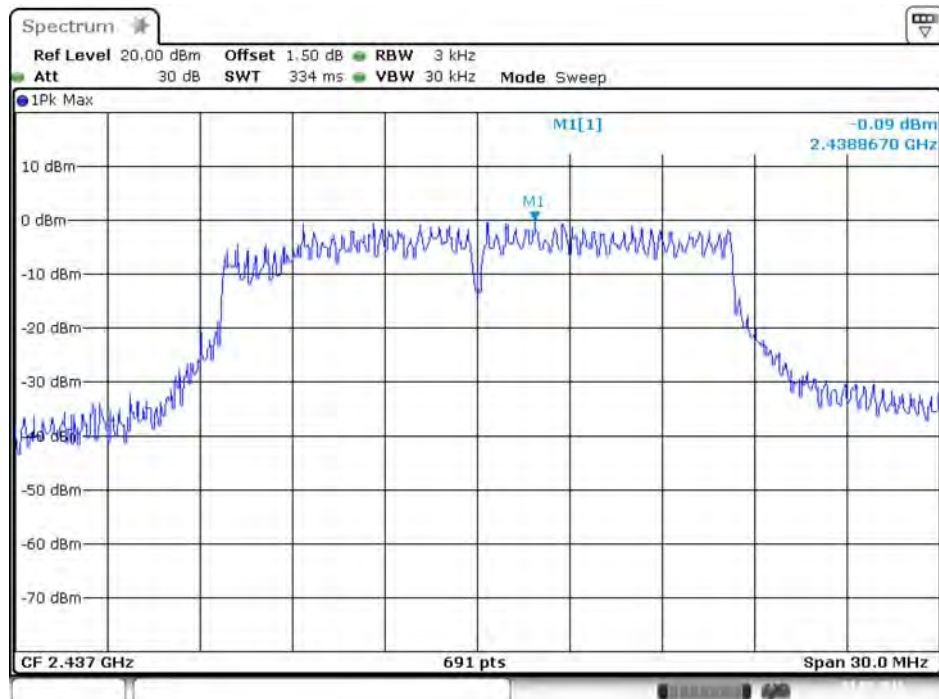

Date: 3.MAY.2016 11:26:01

Power Density Plot on Configuration IEEE 802.11g / 2437 MHz / Chain 2

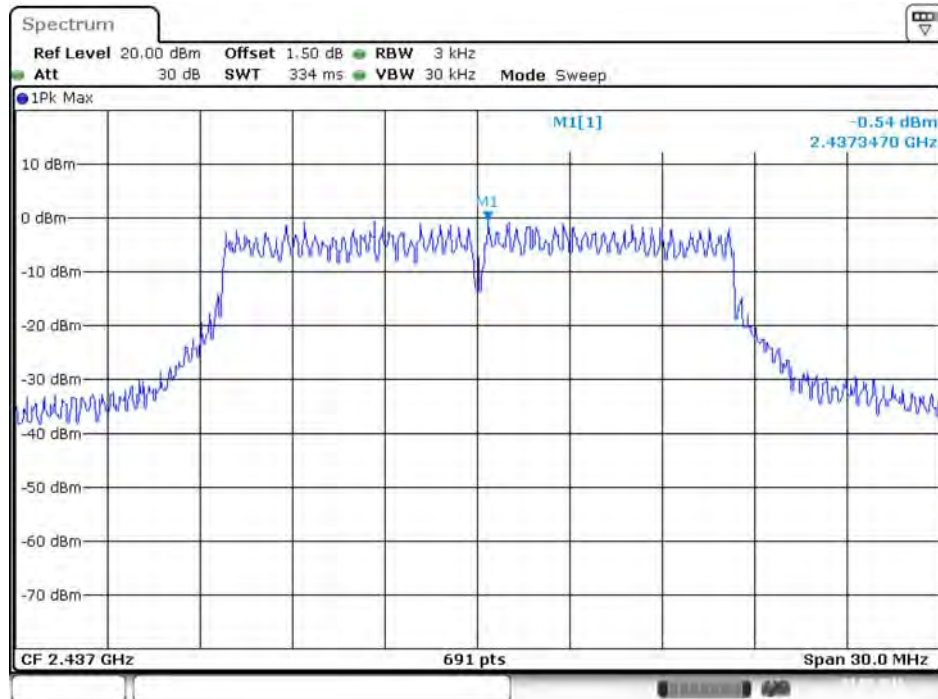

Date: 3.MAY.2016 11:35:05

Power Density Plot on Configuration IEEE 802.11g / 2437 MHz / Chain 3

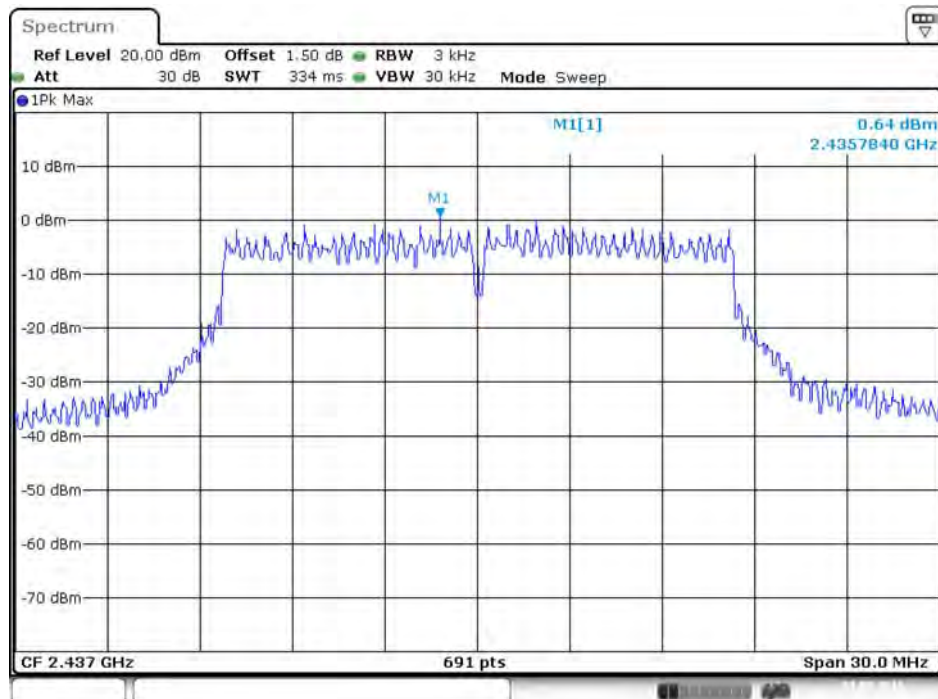

Date: 3.MAY.2016 11:35:23

Power Density Plot on Configuration IEEE 802.11ac MCS0/Nss1 VHT20 / 2437 MHz / Chain 1

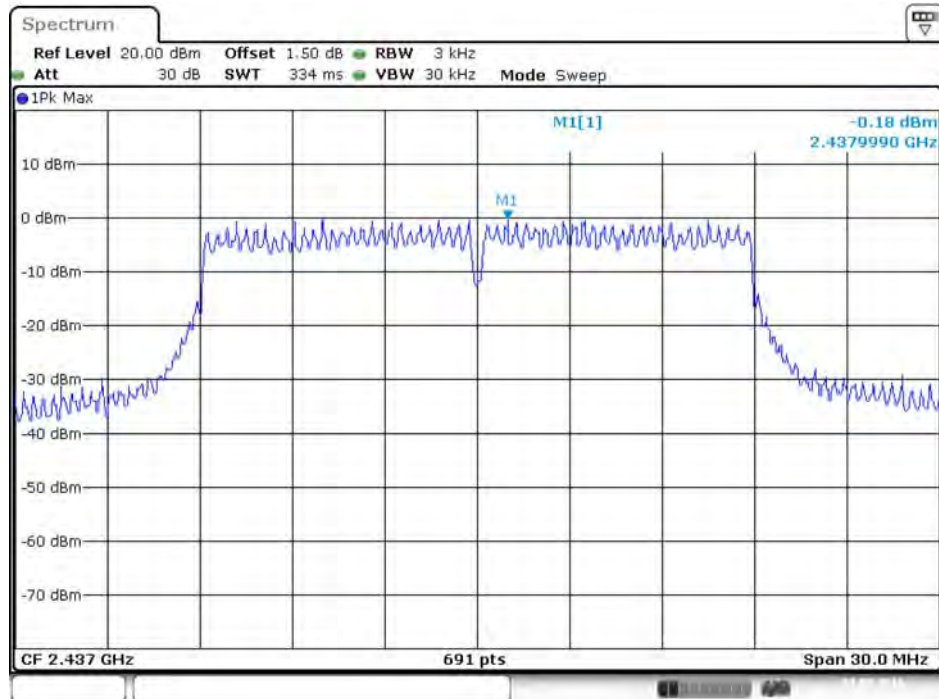

Date: 3.MAY.2016 11:49:23

Power Density Plot on Configuration IEEE 802.11ac MCS0/Nss1 VHT20 / 2437 MHz / Chain 2

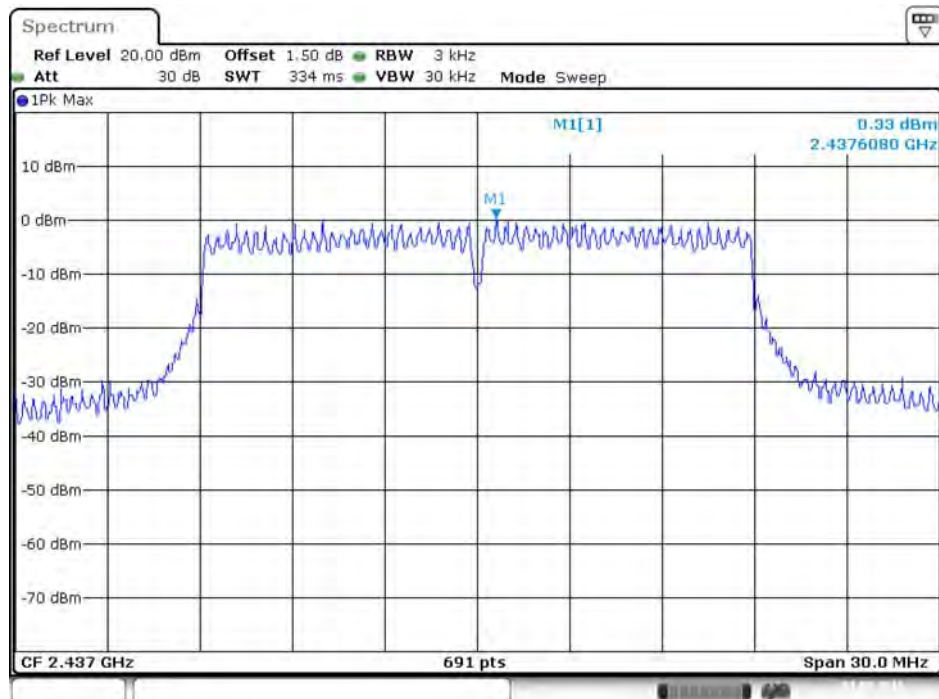

Date: 3.MAY.2016 11:49:44

Power Density Plot on Configuration IEEE 802.11ac MCS0/Nss1 VHT20 / 2437 MHz / Chain 3

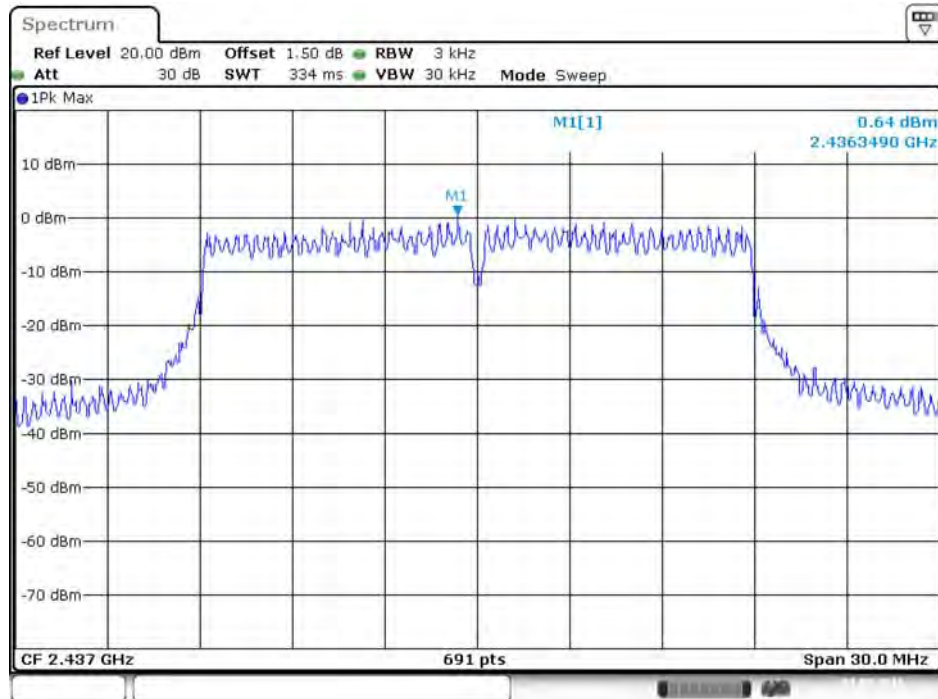

Date: 3.MAY.2016 11:50:11

Power Density Plot on Configuration IEEE 802.11ac MCS0/NSS1 VHT40 / 2437 MHz / Chain 1

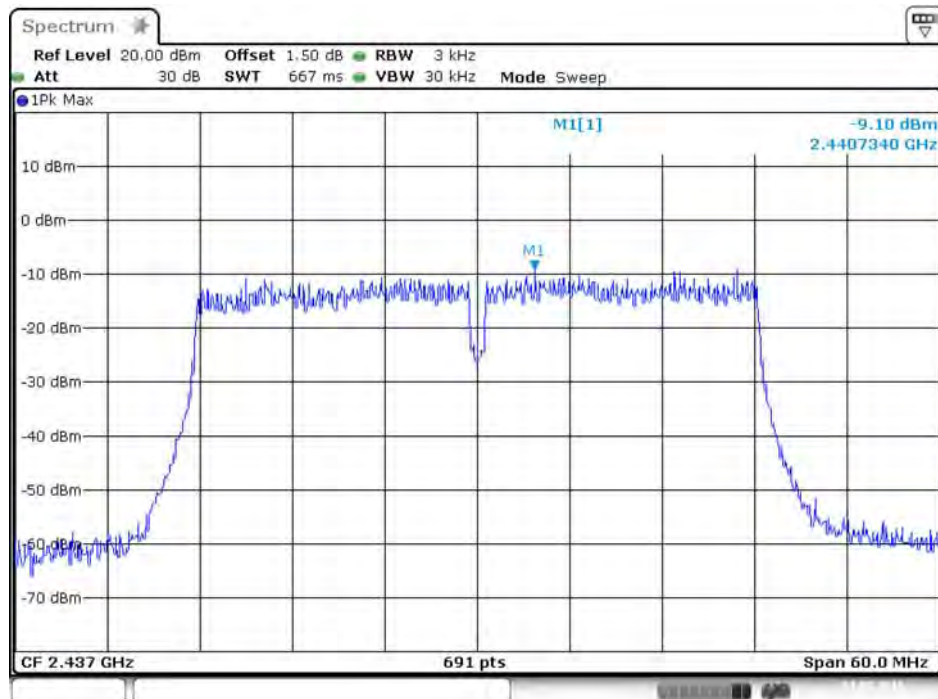

Date: 3.MAY.2016 13:41:34

Power Density Plot on Configuration IEEE 802.11ac MCS0/NSS1 VHT40 / 2437 MHz / Chain 2

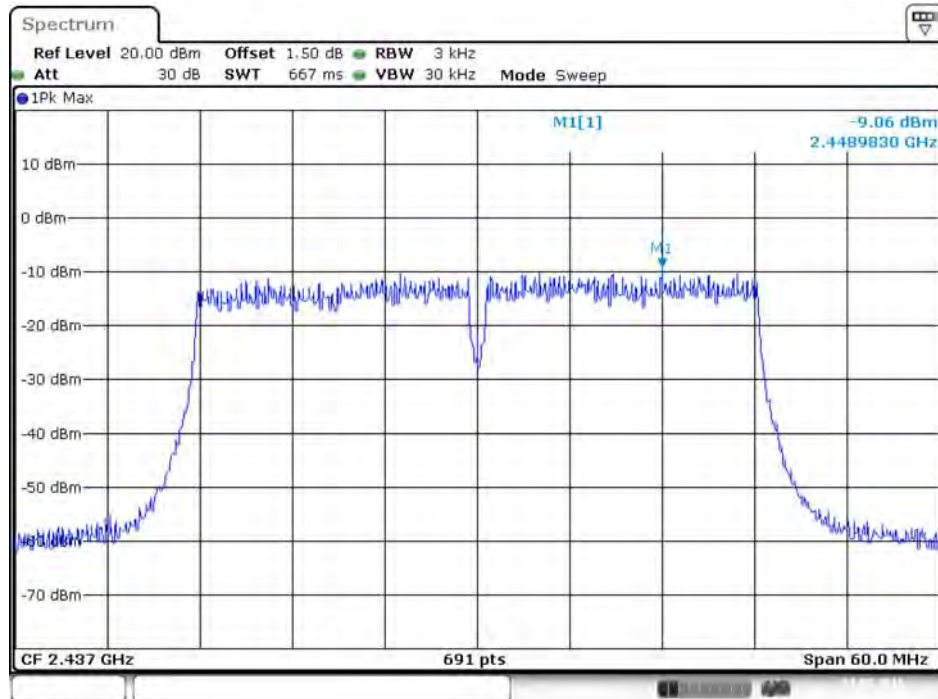

Date: 3.MAY.2016 13:41:53

Power Density Plot on Configuration IEEE 802.11ac MCS0/NSS1 VHT40 / 2437 MHz / Chain 3

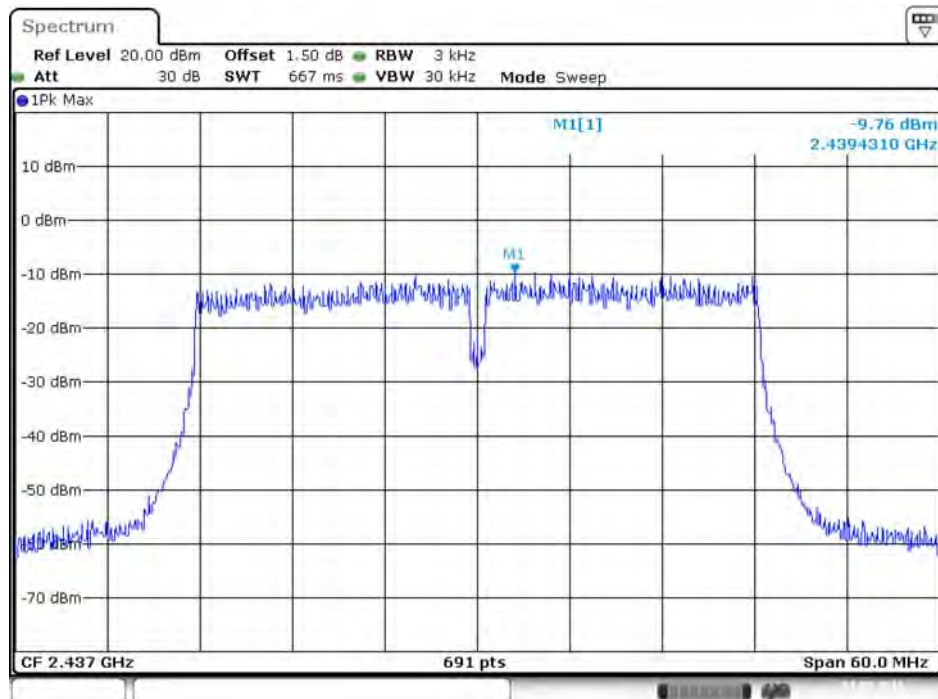

Date: 3.MAY.2016 13:42:10

<For beamforming mode>

Power Density Plot on Configuration IEEE 802.11ac MCS0/Nss1 VHT20 / 2437 MHz / Chain 1

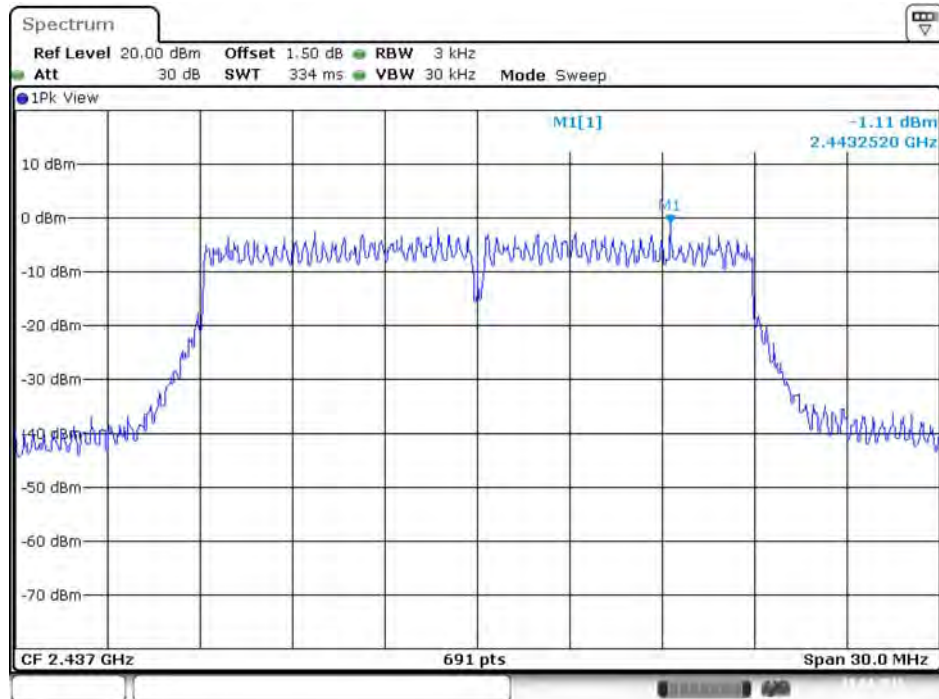

Date: 19.APR.2016 10:41:06

Power Density Plot on Configuration IEEE 802.11ac MCS0/Nss1 VHT20 / 2437 MHz / Chain 2

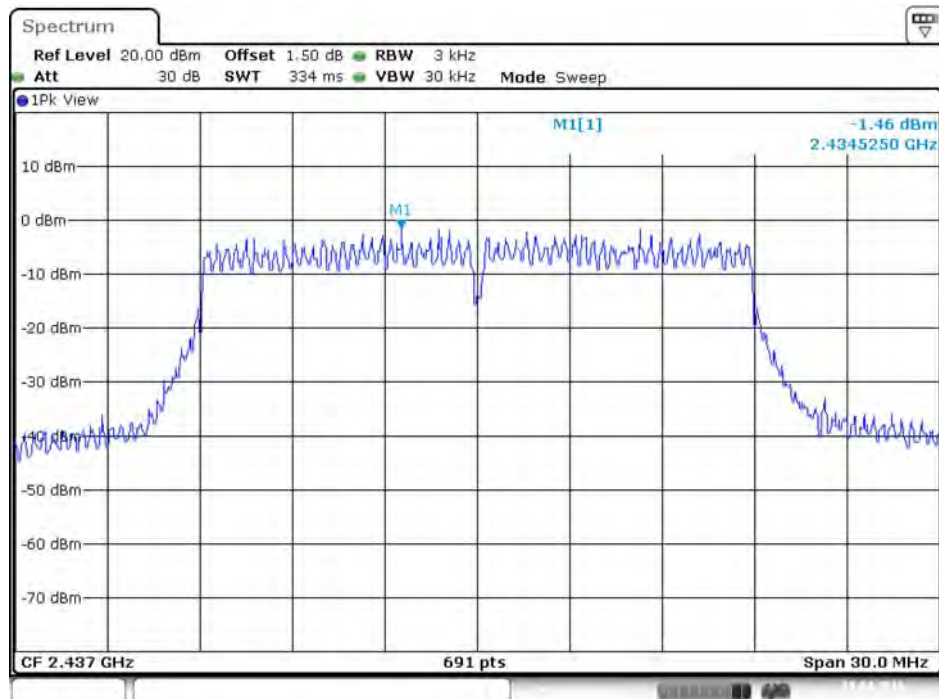

Date: 19.APR.2016 10:40:32

Power Density Plot on Configuration IEEE 802.11ac MCS0/Nss1 VHT20 / 2437 MHz / Chain 3

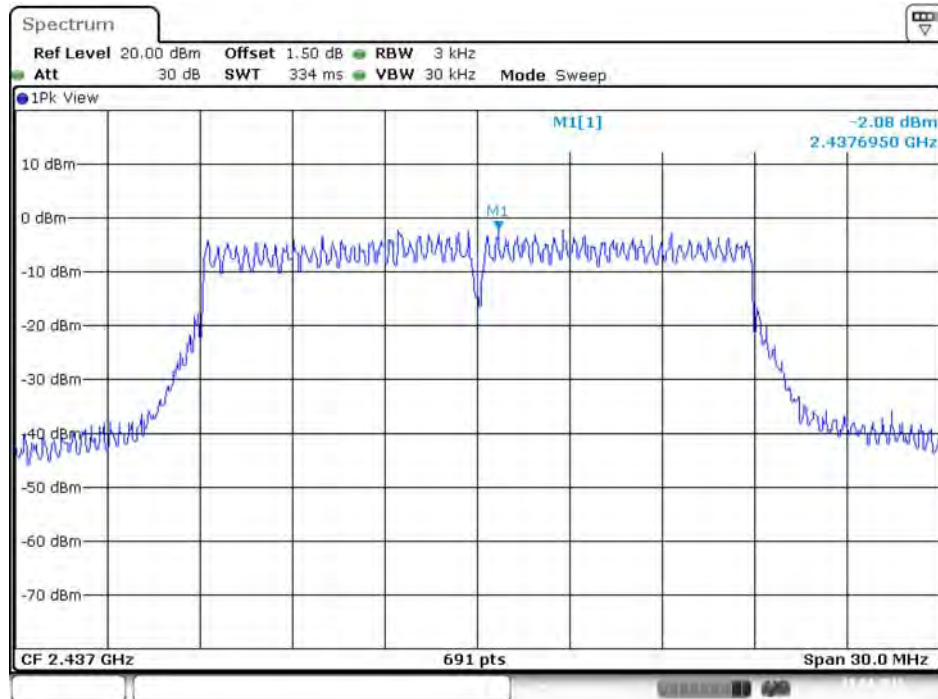

Date: 19.APR.2016 10:39:59

Power Density Plot on Configuration IEEE 802.11ac MCS0/NSS1 VHT40 / 2437 MHz / Chain 1

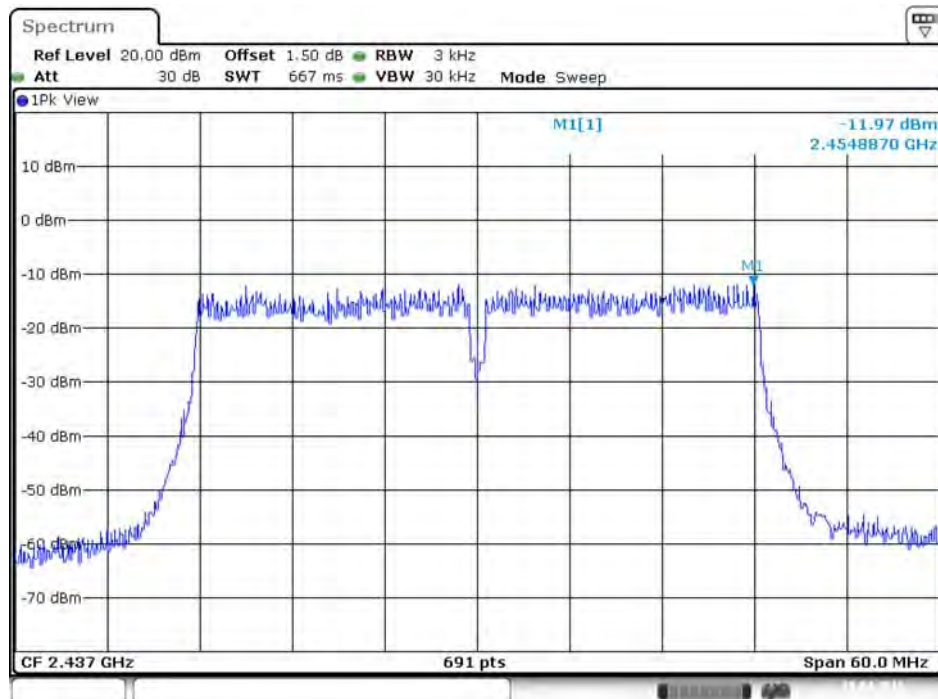

Date: 19.APR.2016 10:45:56

Power Density Plot on Configuration IEEE 802.11ac MCS0/NSS1 VHT40 / 2437 MHz / Chain 2

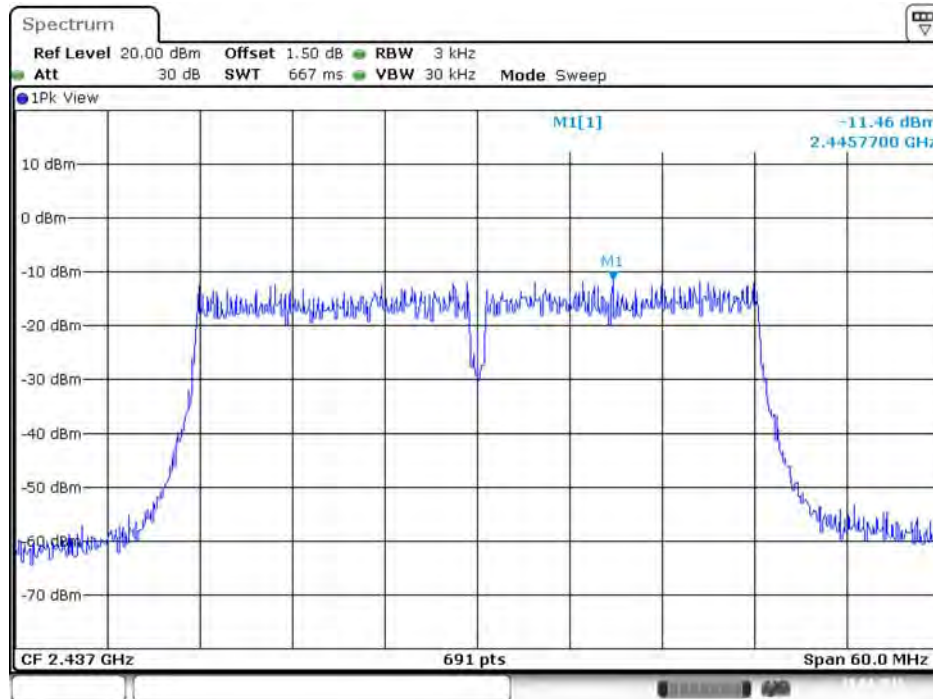

Date: 19.APR.2016 10:46:10

Power Density Plot on Configuration IEEE 802.11ac MCS0/NSS1 VHT40 / 2437 MHz / Chain 3

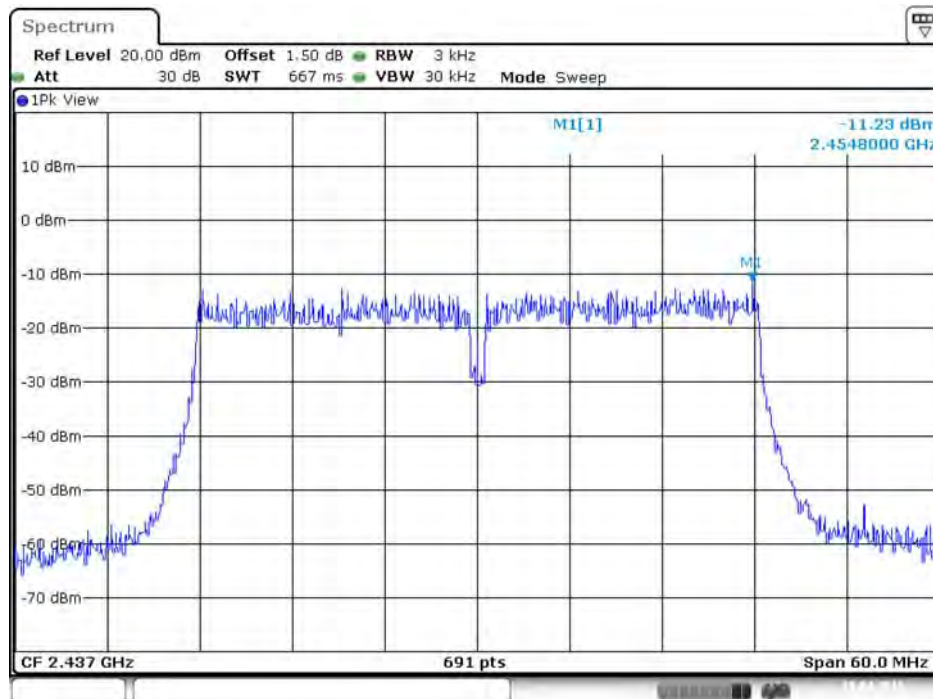

Date: 19.APR.2016 10:46:24

4.4. 6dB Spectrum Bandwidth Measurement

4.4.1. Limit

For digital modulation systems, the minimum 6dB bandwidth shall be at least 500 kHz.

4.4.2. Measuring Instruments and Setting

Please refer to section 5 of equipments list in this report. The following table is the setting of spectrum analyzer.

6dB Spectrum Bandwidth	
Spectrum Parameters	Setting
Attenuation	Auto
Span Frequency	> 6dB Bandwidth
RBW	100kHz
VBW	$\geq 3 \times \text{RBW}$
Detector	Peak
Trace	Max Hold
Sweep Time	Auto
99% Occupied Bandwidth	
Spectrum Parameters	Setting
Span	1.5 times to 5.0 times the OBW
RBW	1 % to 5 % of the OBW
VBW	$\geq 3 \times \text{RBW}$
Detector	Peak
Trace	Max Hold

4.4.3. Test Procedures

For Radiated 6dB Bandwidth Measurement:

1. The transmitter was radiated to the spectrum analyzer in peak hold mode.
2. Test was performed in accordance with KDB558074 D01 v03r05 for Performing Compliance Measurements on Digital Transmission Systems (DTS) - section 8.0 DTS bandwidth=> 8.1 Option 1.
3. Multiple antenna system was performed in accordance with KDB 662911 D01 v02r01 Emissions Testing of Transmitters with Multiple Outputs in the Same Band.
4. Measured the spectrum width with power higher than 6dB below carrier.

4.4.4. Test Setup Layout

For Radiated 6dB Bandwidth Measurement:

This test setup layout is the same as that shown in section 4.5.4.

4.4.5. Test Deviation

There is no deviation with the original standard.

4.4.6. EUT Operation during Test

The EUT was programmed to be in continuously transmitting mode.

4.4.7. Test Result of 6dB Spectrum Bandwidth

Temperature	25°C	Humidity	65%
Test Engineer	Andy Tsai		
Test Function	For non-beamforming mode		

Mode	Frequency	6dB Bandwidth (MHz)	99% Occupied Bandwidth (MHz)	Min. Limit (kHz)	Test Result
802.11b	2412 MHz	8.06	12.07	500	Complies
	2437 MHz	8.12	12.07	500	Complies
	2462 MHz	7.59	12.07	500	Complies
802.11g	2412 MHz	16.46	16.93	500	Complies
	2437 MHz	16.41	17.28	500	Complies
	2462 MHz	16.17	16.93	500	Complies
802.11ac MCS0/Nss1 VHT20	2412 MHz	15.48	17.89	500	Complies
	2437 MHz	17.33	18.06	500	Complies
	2462 MHz	17.74	17.97	500	Complies
802.11ac MCS0/NSS1 VHT40	2422 MHz	35.71	36.47	500	Complies
	2437 MHz	35.71	36.32	500	Complies
	2452 MHz	35.71	36.32	500	Complies

Temperature	25°C	Humidity	65%
Test Engineer	Andy Tsai		
Test Function	For beamforming mode		

Mode	Frequency	6dB Bandwidth (MHz)	99% Occupied Bandwidth (MHz)	Min. Limit (kHz)	Test Result
802.11ac MCS0/Nss1 VHT20	2412 MHz	17.62	17.89	500	Complies
	2437 MHz	16.93	17.89	500	Complies
	2462 MHz	17.57	17.89	500	Complies
802.11ac MCS0/NSS1 VHT40	2422 MHz	35.71	36.76	500	Complies
	2437 MHz	36.06	36.76	500	Complies
	2452 MHz	36.06	36.76	500	Complies

Note: All the test values were listed in the report.

For plots, only the channel with worse result was shown.

<For non-beamforming mode>

6 dB Bandwidth Plot on Configuration IEEE 802.11b / 2462Hz / Chain 1 + Chain 2 + Chain 3

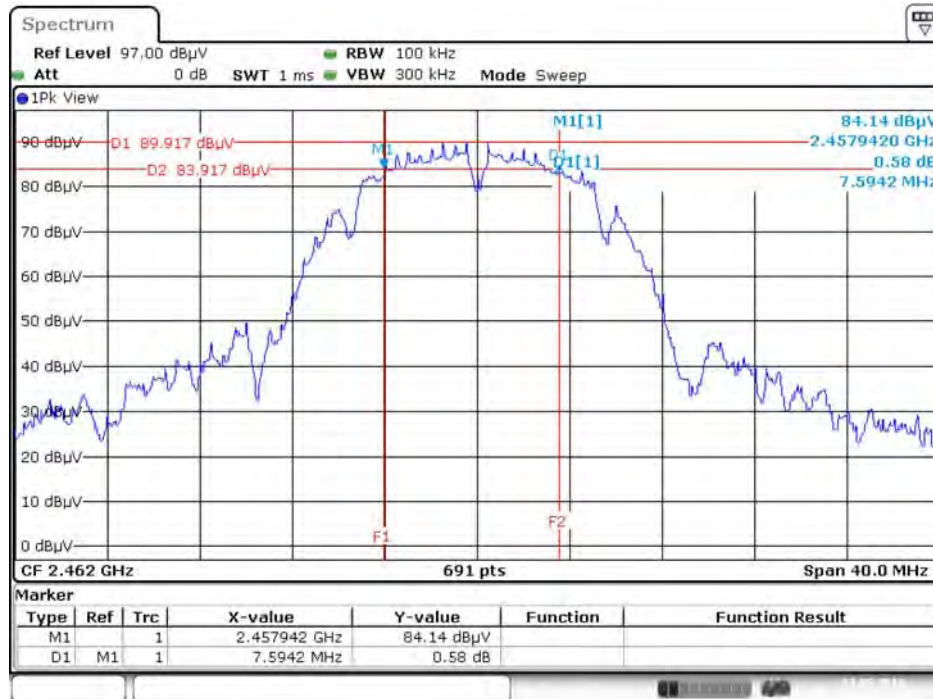

Date: 3.MAY.2016 14:15:16

99% Occupied Bandwidth Plot on Configuration IEEE 802.11b / 2437Hz / Chain 1 + Chain 2 + Chain 3

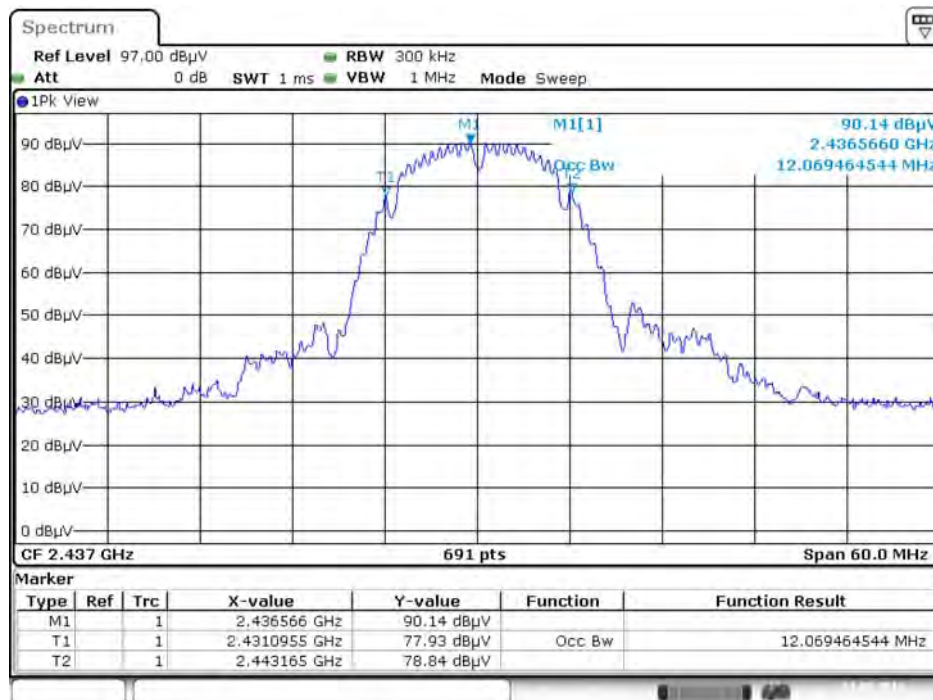

Date: 3.MAY.2016 13:58:45

6 dB Bandwidth Plot on Configuration IEEE 802.11g / 2462 MHz / Chain 1 + Chain 2 + Chain 3

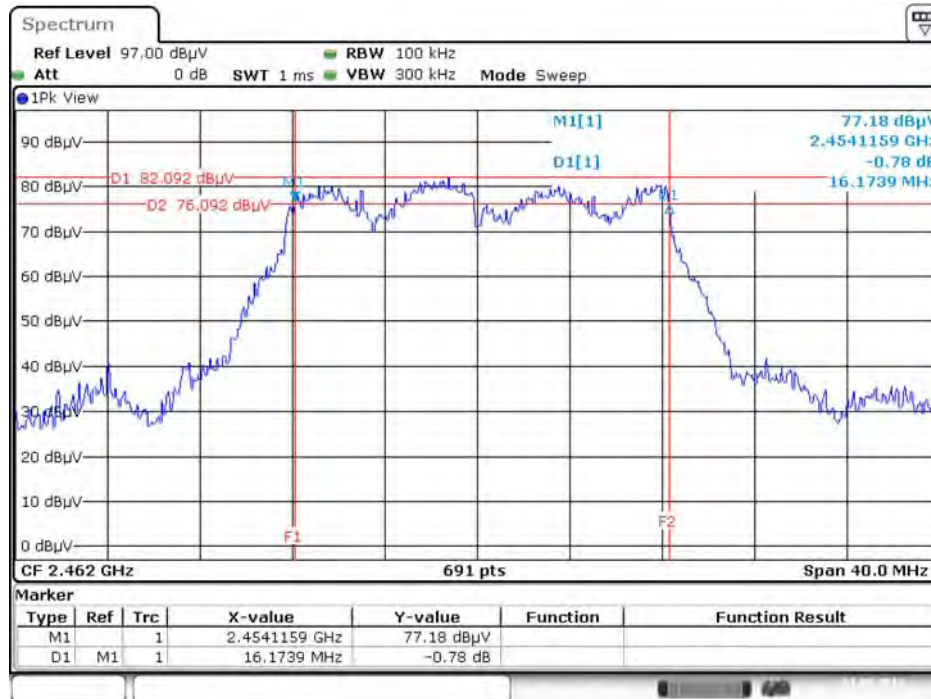

Date: 3.MAY.2016 14:17:30

99% Occupied Bandwidth Plot on Configuration IEEE 802.11g / 2437 MHz / Chain 1 + Chain 2 + Chain 3



Date: 3.MAY.2016 14:01:05

6 dB Bandwidth Plot on Configuration IEEE 802.11ac MCS0/Nss1 VHT20 / 2412 MHz / Chain 1 + Chain 2 + Chain 3

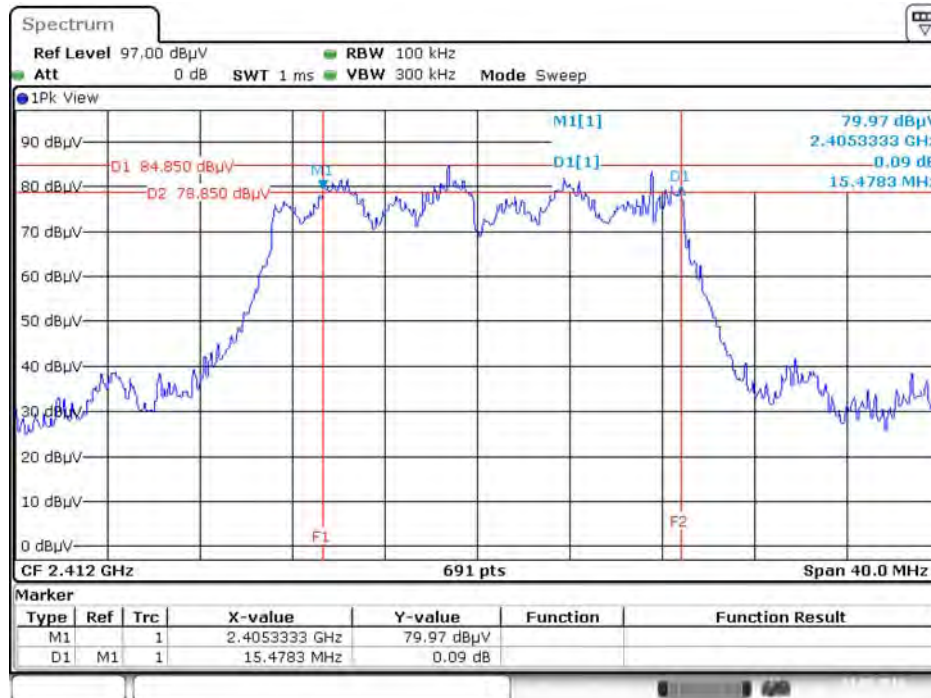

Date: 3.MAY.2016 14:18:25

99% Occupied Bandwidth Plot on Configuration IEEE 802.11ac MCS0/Nss1 VHT20 / 2437 MHz / Chain 1 + Chain 2 + Chain 3



Date: 3.MAY.2016 14:03:00

6 dB Bandwidth Plot on Configuration IEEE 802.11ac MCS0/NSS1 VHT40 / 2422 MHz / Chain 1 + Chain 2 + Chain 3

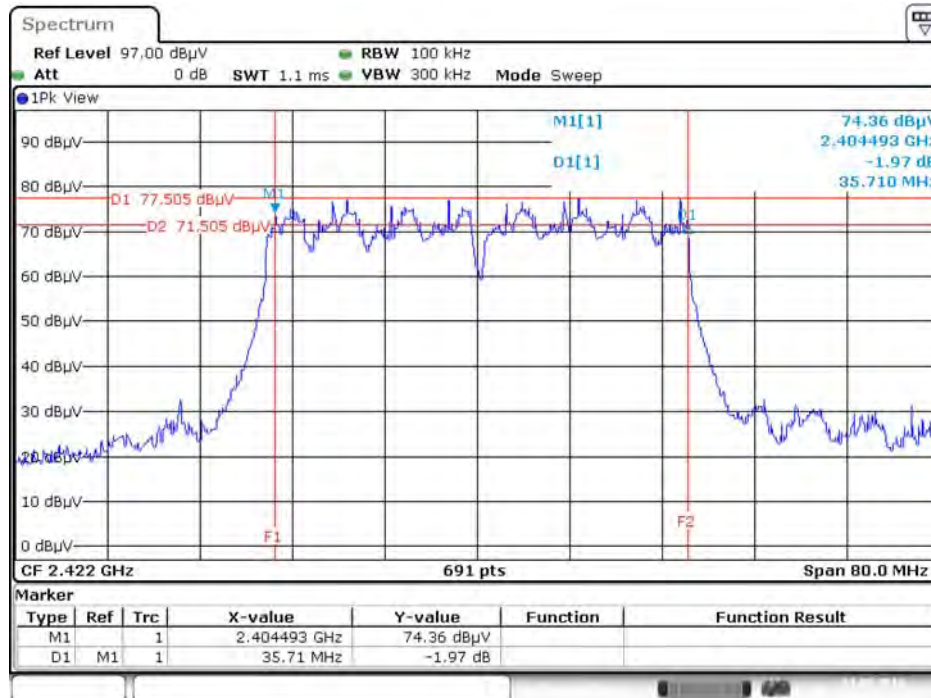

Date: 3.MAY.2016 14:20:10

99% Occupied Bandwidth Plot on Configuration IEEE 802.11ac MCS0/NSS1 VHT40 / 2422 MHz / Chain 1 + Chain 2 + Chain 3

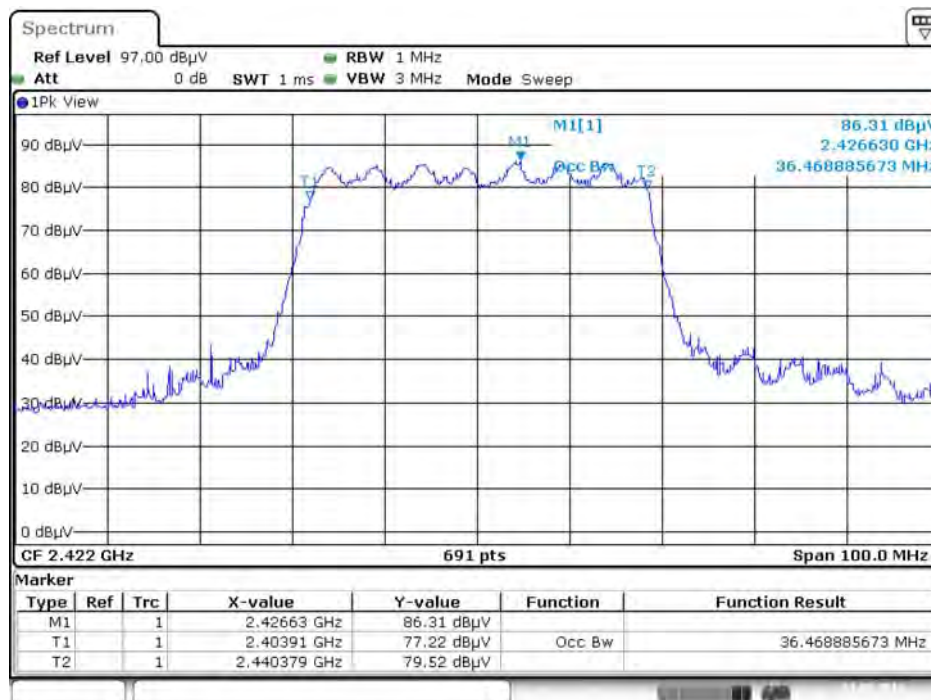

Date: 3.MAY.2016 14:04:34

<For beamforming mode>

6 dB Bandwidth Plot on Configuration IEEE 802.11ac MCS0/Nss1 VHT20 / 2437 MHz / Chain 1 + Chain 2 + Chain 3

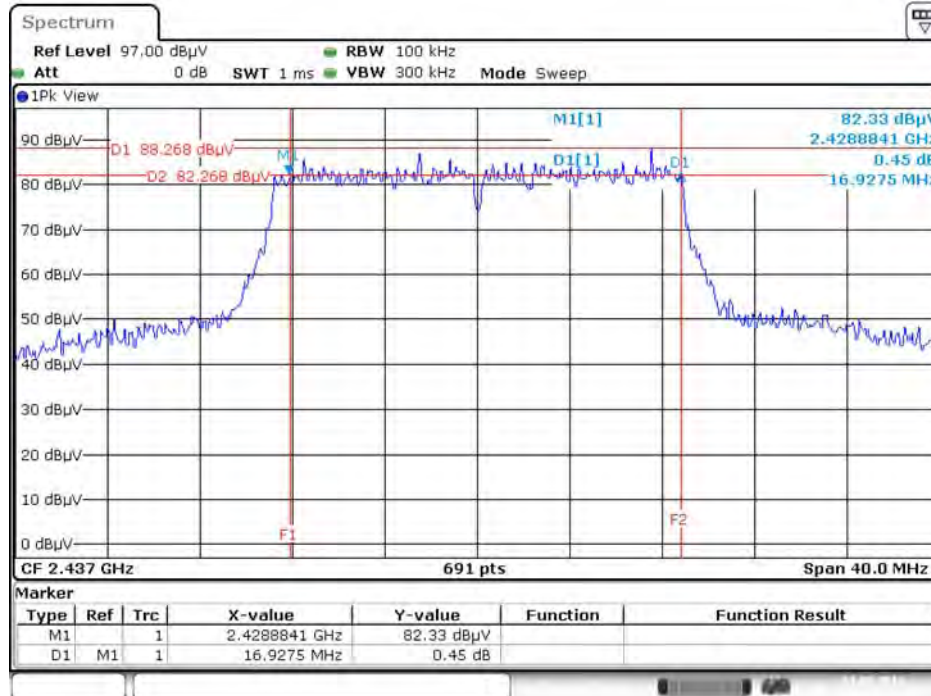

Date: 3.MAY.2016 14:23:31

99% Occupied Bandwidth Plot on Configuration IEEE 802.11ac MCS0/Nss1 VHT20 / 2412 MHz / Chain 1 + Chain 2 + Chain 3



Date: 3.MAY.2016 14:07:05

6 dB Bandwidth Plot on Configuration IEEE 802.11ac MCS0/NSS1 VHT40 / 2422 MHz / Chain 1 + Chain 2 + Chain 3

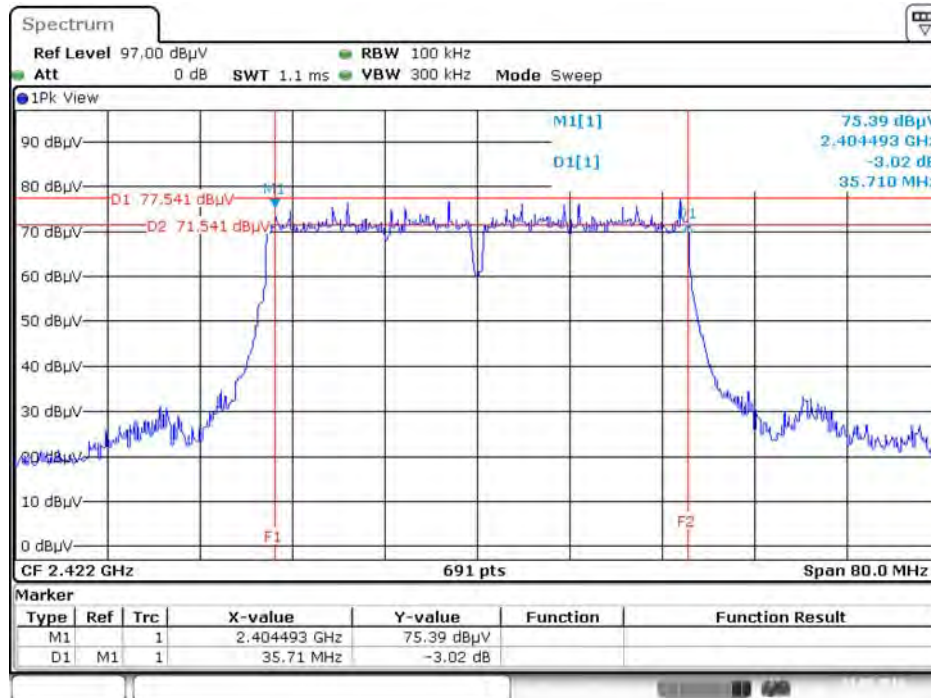

Date: 3.MAY.2016 14:25:26

99% Occupied Bandwidth Plot on Configuration IEEE 802.11ac MCS0/NSS1 VHT40 / 2422 MHz / Chain 1 + Chain 2 + Chain 3

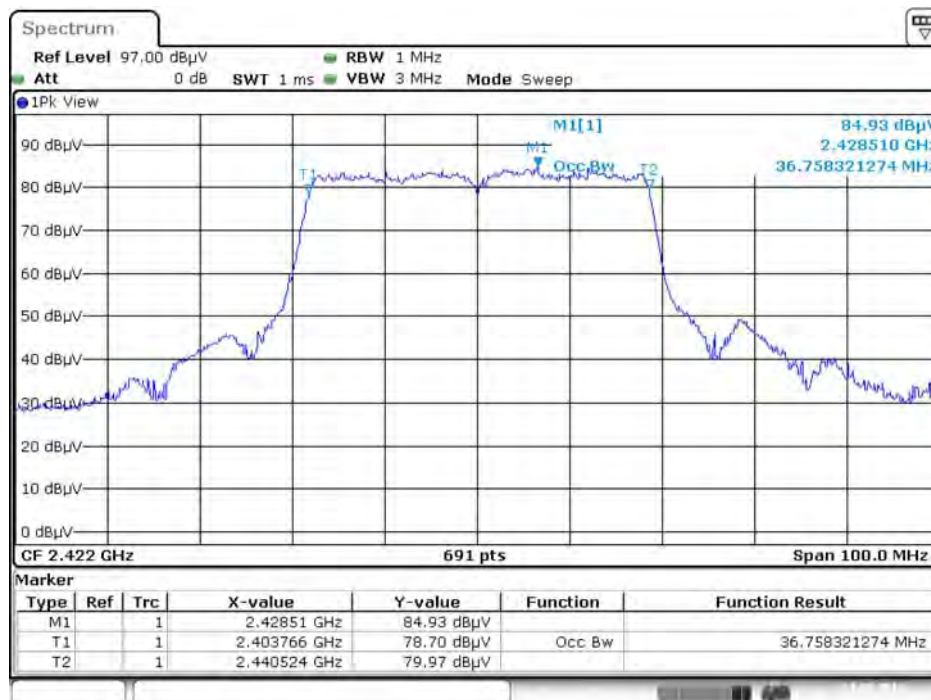

Date: 3.MAY.2016 14:09:05

4.5. Radiated Emissions Measurement

4.5.1. Limit

30dBc in any 100 kHz bandwidth outside the operating frequency band. In case the emission fall within the restricted band specified on 15.205(a), then the 15.209(a) limit in the table below has to be followed.

Frequencies (MHz)	Field Strength (micorvolts/meter)	Measurement Distance (meters)
0.009~0.490	2400/F(kHz)	300
0.490~1.705	24000/F(kHz)	30
1.705~30.0	30	30
30~88	100	3
88~216	150	3
216~960	200	3
Above 960	500	3

4.5.2. Measuring Instruments and Setting

Please refer to section 5 of equipments list in this report. The following table is the setting of spectrum analyzer and receiver.

Spectrum Parameter	Setting
Attenuation	Auto
Start Frequency	1000 MHz
Stop Frequency	10th carrier harmonic
RBW / VBW (Emission in restricted band)	1MHz / 3MHz for Peak, 1MHz / 1/T for Average
RBW / VBW (Emission in non-restricted band)	100kHz / 300kHz for peak

Receiver Parameter	Setting
Attenuation	Auto
Start ~ Stop Frequency	9kHz~150kHz / RBW 200Hz for QP
Start ~ Stop Frequency	150kHz~30MHz / RBW 9kHz for QP
Start ~ Stop Frequency	30MHz~1GHz / RBW 120kHz for QP

4.5.3. Test Procedures

1. Configure the EUT according to ANSI C63.10. The EUT was placed on the top of the turntable 1.5 meter above ground. The phase center of the receiving antenna mounted on the top of a height-variable antenna tower was placed 1m & 3m far away from the turntable.
2. Power on the EUT and all the supporting units. The turntable was rotated by 360 degrees to determine the position of the highest radiation.
3. The height of the broadband receiving antenna was varied between one meter and four meters above ground to find the maximum emissions field strength of both horizontal and vertical polarization.
4. For each suspected emissions, the antenna tower was scan (from 1 M to 4 M) and then the turntable was rotated (from 0 degree to 360 degrees) to find the maximum reading.
5. Set the test-receiver system to Peak or CISPR quasi-peak Detect Function with specified bandwidth under Maximum Hold Mode.
6. For emissions above 1GHz, use 1MHz VBW and 3MHz RBW for peak reading. Then 1MHz RBW and 1/T VBW for average reading in spectrum analyzer.
7. If the emissions level of the EUT in peak mode was 3 dB lower than the average limit specified, then testing will be stopped and peak values of EUT will be reported, otherwise, the emissions which do not have 3 dB margin will be repeated one by one using the quasi-peak method for below 1GHz.
8. For testing above 1GHz, the emissions level of the EUT in peak mode was lower than average limit (that means the emissions level in peak mode also complies with the limit in average mode), then testing will be stopped and peak values of EUT will be reported, otherwise, the emissions will be measured in average mode again and reported.
9. In case the emission is lower than 30MHz, loop antenna has to be used for measurement and the recorded data should be QP measured by receiver. High – Low scan is not required in this case.

4.5.4. Test Setup Layout

For Radiated Emissions: 9kHz ~30MHz

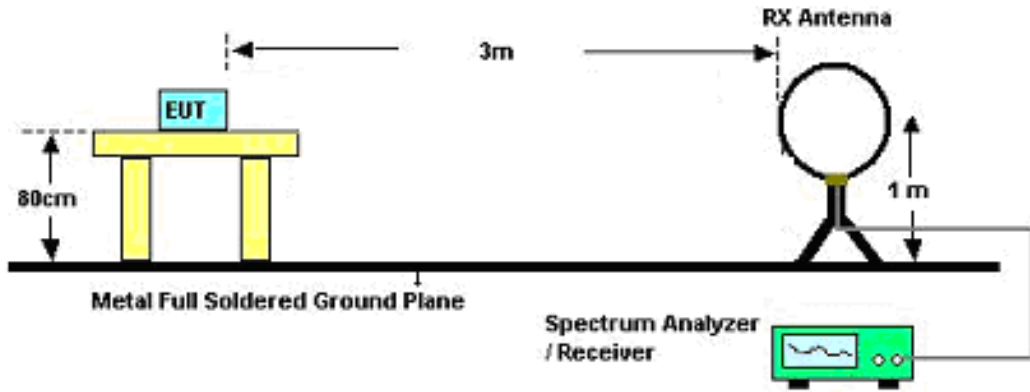

For Radiated Emissions: 30MHz~1GHz

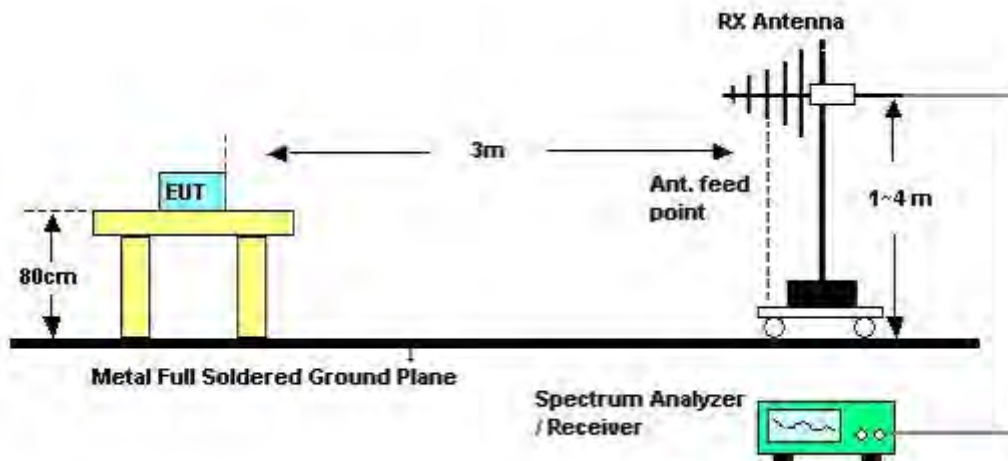

For Radiated Emissions: Above 1GHz

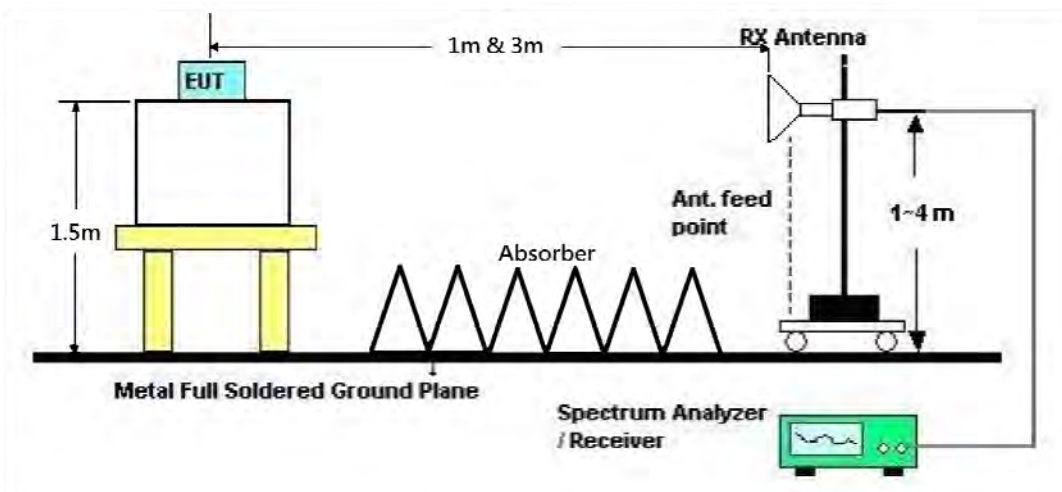

4.5.5. Test Deviation

There is no deviation with the original standard.

4.5.6. EUT Operation during Test

For non-beamforming mode:

The EUT was programmed to be in continuously transmitting mode.

For beamforming mode:

The EUT was programmed to be in beamforming transmitting mode.

4.5.7. Results of Radiated Emissions (9kHz~30MHz)

Temperature	26°C	Humidity	64%
Test Engineer	Gino Huang	Configurations	CTX
Test Date	Jul. 20, 2016	Test Mode	Mode 2

Freq. (MHz)	Level (dBuV)	Over Limit (dB)	Limit Line (dBuV)	Remark
-	-	-	-	See Note

Note:

The amplitude of spurious emissions that are attenuated by more than 20 dB below the permissible value has no need to be reported.

Distance extrapolation factor = $40 \log(\text{specific distance} / \text{test distance})$ (dB);

Limit line = specific limits (dBuV) + distance extrapolation factor.

4.5.8. Results of Radiated Emissions (30MHz~1GHz)

Temperature	26°C	Humidity	64%
Test Engineer	Gino Huang	Configurations	CTX
Test Mode	Mode 2		

Horizontal

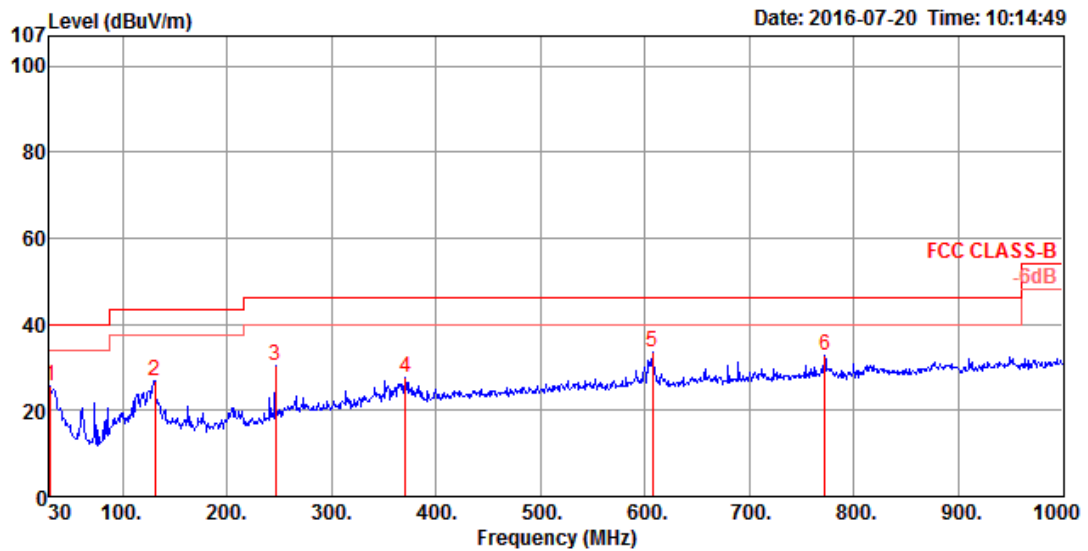

	Freq	Level	Limit	Over	Read	CableAntenna	Preamp	A/Pos	T/Pos	Remark	PoI/Phase
	MHz	dBuV/m	dBuV/m	dB	dBuV	dB	dB/m	dB	cm	deg	
1	30.97	25.68	40.00	-14.32	32.97	0.54	24.81	32.64	150	181 Peak	HORIZONTAL
2	130.88	27.03	43.50	-16.47	40.42	1.12	18.05	32.56	200	236 Peak	HORIZONTAL
3	246.31	30.44	46.00	-15.56	43.20	1.54	18.23	32.53	150	135 Peak	HORIZONTAL
4	370.47	27.61	46.00	-18.39	36.74	1.89	21.51	32.53	125	204 Peak	HORIZONTAL
5	607.15	33.42	46.00	-12.58	38.81	2.40	24.89	32.68	150	217 Peak	HORIZONTAL
6	772.05	32.67	46.00	-13.33	36.08	2.72	26.32	32.45	100	160 Peak	HORIZONTAL

Vertical

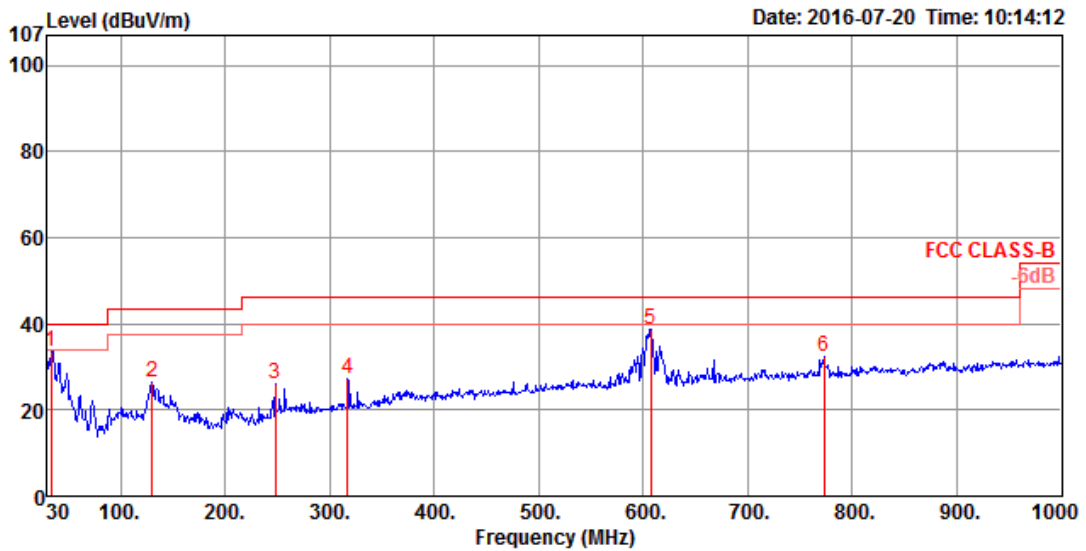

	Freq	Level	Limit	Over	Read	CableAntenna	Preamp	A/Pos	T/Pos	Remark	Pol/Phase
	MHz	dBuV/m	dBuV/m	dB	dBuV	dB	dB/m	dB	cm	deg	
1	33.88	33.55	40.00	-6.45	42.51	0.59	23.09	32.64	100	205 Peak	VERTICAL
2	129.91	26.29	43.50	-17.21	39.63	1.12	18.10	32.56	125	282 Peak	VERTICAL
3	248.25	25.97	46.00	-20.03	38.50	1.55	18.45	32.53	150	228 Peak	VERTICAL
4	317.12	27.13	46.00	-18.87	37.82	1.75	20.08	32.52	200	323 Peak	VERTICAL
5	607.15	38.73	46.00	-7.27	44.12	2.40	24.89	32.68	100	168 Peak	VERTICAL
6	773.02	32.47	46.00	-13.53	35.85	2.72	26.35	32.45	100	218 Peak	VERTICAL

Note:

The amplitude of spurious emissions that are attenuated by more than 20dB below the permissible value has no need to be reported.

Emission level (dBuV/m) = 20 log Emission level (uV/m).

Corrected Reading: Antenna Factor + Cable Loss + Read Level - Preamp Factor = Level.

4.5.9. Results for Radiated Emissions (1GHz~10th Harmonic)

<For non-beamforming mode>

Temperature	26°C	Humidity	64%
Test Engineer	Gino Huang	Configurations	IEEE 802.11b CH 1 / Chain 1 + Chain 2 + Chain 3
Test Date	Apr. 13, 2016 ~ Apr. 14, 2016		

Horizontal

	Freq	Level	Limit Line	Over Limit	Read Level	CableAntenna Loss	Antenna Factor	Preamp Factor	A/Pos	T/Pos	Remark	Pol/Phase
	MHz	dBuV/m	dBuV/m	dB	dBuV	dB	dB/m	dB	cm	deg		
1	4824.28	47.50	74.00	-26.50	41.85	7.64	31.09	33.08	300	99	Peak	HORIZONTAL
2	4824.32	38.74	54.00	-15.26	33.09	7.64	31.09	33.08	300	99	Average	HORIZONTAL

Vertical

	Freq	Level	Limit Line	Over Limit	Read Level	CableAntenna Loss	Antenna Factor	Preamp Factor	A/Pos	T/Pos	Remark	Pol/Phase
	MHz	dBuV/m	dBuV/m	dB	dBuV	dB	dB/m	dB	cm	deg		
1	4824.28	43.09	54.00	-10.91	37.44	7.64	31.09	33.08	300	33	Average	VERTICAL
2	4824.48	48.19	74.00	-25.81	42.54	7.64	31.09	33.08	300	33	Peak	VERTICAL



Temperature	26°C	Humidity	64%
Test Engineer	Gino Huang	Configurations	IEEE 802.11b CH 6 / Chain 1 + Chain 2 + Chain 3
Test Date	Apr. 14, 2016		

Horizontal

	Freq	Level	Limit Line	Over Limit	Read Level	CableAntenna Loss	Antenna Factor	Preamp Factor	A/Pos	T/Pos	Remark	Pol/Phase
	MHz	dBuV/m	dBuV/m	dB	dBuV	dB	dB/m	dB	cm	deg		
1	4873.96	47.05	74.00	-26.95	41.28	7.70	31.15	33.08	300	102	Peak	HORIZONTAL
2	4874.28	39.93	54.00	-14.07	34.16	7.70	31.15	33.08	300	102	Average	HORIZONTAL

Vertical

	Freq	Level	Limit Line	Over Limit	Read Level	CableAntenna Loss	Antenna Factor	Preamp Factor	A/Pos	T/Pos	Remark	Pol/Phase
	MHz	dBuV/m	dBuV/m	dB	dBuV	dB	dB/m	dB	cm	deg		
1	4874.32	43.03	54.00	-10.97	37.26	7.70	31.15	33.08	100	324	Average	VERTICAL
2	4874.32	48.99	74.00	-25.01	43.22	7.70	31.15	33.08	100	324	Peak	VERTICAL



Temperature	26°C	Humidity	64%
Test Engineer	Gino Huang	Configurations	IEEE 802.11b CH 11 / Chain 1 + Chain 2 + Chain 3
Test Date	Apr. 14, 2016		

Horizontal

	Freq	Level	Limit Line	Over Limit	Read Level	Cable Loss	Antenna Factor	Preamp Factor	A/Pos	T/Pos	Remark	Pol/Phase
	MHz	dBuV/m	dBuV/m	dB	dBuV	dB	dB/m	dB	cm	deg		
1	4924.28	41.59	54.00	-12.41	35.68	7.76	31.22	33.07	299	39	Average	HORIZONTAL
2	4924.28	47.26	74.00	-26.74	41.35	7.76	31.22	33.07	299	39	Peak	HORIZONTAL

Vertical

	Freq	Level	Limit Line	Over Limit	Read Level	Cable Loss	Antenna Factor	Preamp Factor	A/Pos	T/Pos	Remark	Pol/Phase
	MHz	dBuV/m	dBuV/m	dB	dBuV	dB	dB/m	dB	cm	deg		
1	4924.32	43.12	54.00	-10.88	37.21	7.76	31.22	33.07	106	333	Average	VERTICAL
2	4924.36	48.99	74.00	-25.01	43.08	7.76	31.22	33.07	106	333	Peak	VERTICAL

Temperature	26°C	Humidity	64%
Test Engineer	Gino Huang	Configurations	IEEE 802.11g CH 1 / Chain 1 + Chain 2 + Chain 3
Test Date	Apr. 14, 2016		

Horizontal

	Freq	Level	Limit	Over	Read	CableAntenna	Preamp	A/Pos	T/Pos	Remark	Pol/Phase
	MHz	dBuV/m	dBuV/m	dB	dBuV	dB	dB/m	dB	cm	deg	
1	4820.72	33.06	54.00	-20.94	27.41	7.64	31.09	33.08	125	47 Average	HORIZONTAL
2	4823.44	46.00	74.00	-28.00	40.35	7.64	31.09	33.08	125	47 Peak	HORIZONTAL

Vertical

	Freq	Level	Limit	Over	Read	CableAntenna	Preamp	A/Pos	T/Pos	Remark	Pol/Phase
	MHz	dBuV/m	dBuV/m	dB	dBuV	dB	dB/m	dB	cm	deg	
1	4818.76	34.96	54.00	-19.04	29.31	7.64	31.09	33.08	125	255 Average	VERTICAL
2	4820.44	46.78	74.00	-27.22	41.13	7.64	31.09	33.08	125	255 Peak	VERTICAL

Temperature	26°C	Humidity	64%
Test Engineer	Gino Huang	Configurations	IEEE 802.11g CH 6 / Chain 1 + Chain 2 + Chain 3
Test Date	Apr. 14, 2016		

Horizontal

	Freq	Level	Limit	Over	Read	CableAntenna	Preamp	A/Pos	T/Pos	Remark	Pol/Phase
	MHz	dBuV/m	dBuV/m	dB	dBuV	dB	dB/m	dB	cm	deg	
1	4870.96	33.26	54.00	-20.74	27.49	7.70	31.15	33.08	125	79 Average	HORIZONTAL
2	4871.08	45.61	74.00	-28.39	39.84	7.70	31.15	33.08	125	79 Peak	HORIZONTAL

Vertical

	Freq	Level	Limit	Over	Read	CableAntenna	Preamp	A/Pos	T/Pos	Remark	Pol/Phase
	MHz	dBuV/m	dBuV/m	dB	dBuV	dB	dB/m	dB	cm	deg	
1	4871.56	34.34	54.00	-19.66	28.57	7.70	31.15	33.08	125	227 Average	VERTICAL
2	4872.48	47.81	74.00	-26.19	42.04	7.70	31.15	33.08	125	227 Peak	VERTICAL

Temperature	26°C	Humidity	64%
Test Engineer	Gino Huang	Configurations	IEEE 802.11g CH 11 / Chain 1 + Chain 2 + Chain 3
Test Date	Apr. 14, 2016		

Horizontal

	Freq	Level	Limit Line	Over Limit	Read Level	CableAntenna Loss	Antenna Factor	Preamp Factor	A/Pos	T/Pos	Remark	Pol/Phase
	MHz	dBuV/m	dBuV/m	dB	dBuV	dB	dB/m	dB	cm	deg		
1	4918.04	33.01	54.00	-20.99	27.13	7.75	31.20	33.07	125	83	Average	HORIZONTAL
2	4918.04	46.18	74.00	-27.82	40.30	7.75	31.20	33.07	125	83	Peak	HORIZONTAL

Vertical

	Freq	Level	Limit Line	Over Limit	Read Level	CableAntenna Loss	Antenna Factor	Preamp Factor	A/Pos	T/Pos	Remark	Pol/Phase
	MHz	dBuV/m	dBuV/m	dB	dBuV	dB	dB/m	dB	cm	deg		
1	4921.36	35.68	54.00	-18.32	29.80	7.75	31.20	33.07	125	267	Average	VERTICAL
2	4923.08	46.53	74.00	-27.47	40.65	7.75	31.20	33.07	125	267	Peak	VERTICAL

Temperature	26°C	Humidity	64%
Test Engineer	Gino Huang	Configurations	IEEE 802.11ac MCS0/Nss1 VHT20 CH 1 / Chain 1 + Chain 2 + Chain 3
Test Date	Apr. 14, 2016		

Horizontal

	Freq	Level	Limit Line	Over Limit	Read Level	CableAntenna Loss	Antenna Factor	Preamp Factor	A/Pos	T/Pos	Remark	Pol/Phase
	MHz	dBuV/m	dBuV/m	dB	dBuV	dB	dB/m	dB	cm	deg		
1	4818.72	32.98	54.00	-21.02	27.33	7.64	31.09	33.08	125	56	Average	HORIZONTAL
2	4818.84	46.72	74.00	-27.28	41.07	7.64	31.09	33.08	125	56	Peak	HORIZONTAL

Vertical

	Freq	Level	Limit Line	Over Limit	Read Level	CableAntenna Loss	Antenna Factor	Preamp Factor	A/Pos	T/Pos	Remark	Pol/Phase
	MHz	dBuV/m	dBuV/m	dB	dBuV	dB	dB/m	dB	cm	deg		
1	4820.52	33.08	54.00	-20.92	27.43	7.64	31.09	33.08	125	268	Average	VERTICAL
2	4822.56	45.49	74.00	-28.51	39.84	7.64	31.09	33.08	125	268	Peak	VERTICAL



Temperature	26°C	Humidity	64%
Test Engineer	Gino Huang	Configurations	IEEE 802.11ac MCS0/Nss1 VHT20 CH 6 / Chain 1 + Chain 2 + Chain 3
Test Date	Apr. 14, 2016		

Horizontal

	Freq	Level	Limit	Over	Read	CableAntenna	Preamp	A/Pos	T/Pos	Remark	Pol/Phase	
	MHz	dBuV/m	dBuV/m	dB	dBuV	dB	dB/m	dB	cm	deg		
1	4870.80	46.55	74.00	-27.45	40.78	7.70	31.15	33.08	125	22	Peak	HORIZONTAL
2	4873.70	33.40	54.00	-20.60	27.63	7.70	31.15	33.08	125	22	Average	HORIZONTAL

Vertical

	Freq	Level	Limit	Over	Read	CableAntenna	Preamp	A/Pos	T/Pos	Remark	Pol/Phase	
	MHz	dBuV/m	dBuV/m	dB	dBuV	dB	dB/m	dB	cm	deg		
1	4873.50	46.00	74.00	-28.00	40.23	7.70	31.15	33.08	125	268	Peak	VERTICAL
2	4876.10	34.76	54.00	-19.24	28.99	7.70	31.15	33.08	125	268	Average	VERTICAL



Temperature	26°C	Humidity	64%
Test Engineer	Gino Huang	Configurations	IEEE 802.11ac MCS0/Nss1 VHT20 CH 11 / Chain 1 + Chain 2 + Chain 3
Test Date	Apr. 14, 2016		

Horizontal

	Freq	Level	Limit	Over	Read	CableAntenna	Preamp	A/Pos	T/Pos	Remark	Pol/Phase	
	MHz	dBuV/m	dBuV/m	dB	dBuV	Loss	Factor	Factor	cm	deg		
1	4907.80	46.06	74.00	-27.94	40.21	7.73	31.19	33.07	125	93	Peak	HORIZONTAL
2	4921.00	33.36	54.00	-20.64	27.48	7.75	31.20	33.07	125	93	Average	HORIZONTAL

Vertical

	Freq	Level	Limit	Over	Read	CableAntenna	Preamp	A/Pos	T/Pos	Remark	Pol/Phase	
	MHz	dBuV/m	dBuV/m	dB	dBuV	Loss	Factor	Factor	cm	deg		
1	4921.50	46.35	74.00	-27.65	40.47	7.75	31.20	33.07	125	275	Peak	VERTICAL
2	4924.10	33.74	54.00	-20.26	27.83	7.76	31.22	33.07	125	275	Average	VERTICAL

Temperature	26°C	Humidity	64%
Test Engineer	Gino Huang	Configurations	IEEE 802.11ac MCS0/Nss1 VHT40 CH 3 / Chain 1 + Chain 2 + Chain 3
Test Date	Apr. 14, 2016		

Horizontal

	Freq	Level	Limit Line	Over Limit	Read Level	CableAntenna Loss	Antenna Factor	Preamp Factor	A/Pos	T/Pos	Remark	Pol/Phase
	MHz	dBuV/m	dBuV/m	dB	dBuV	dB	dB/m	dB	cm	deg		
1	4845.30	46.31	74.00	-27.69	40.60	7.67	31.12	33.08	125	35	Peak	HORIZONTAL
2	4866.20	33.25	54.00	-20.75	27.51	7.68	31.14	33.08	125	35	Average	HORIZONTAL

Vertical

	Freq	Level	Limit Line	Over Limit	Read Level	CableAntenna Loss	Antenna Factor	Preamp Factor	A/Pos	T/Pos	Remark	Pol/Phase
	MHz	dBuV/m	dBuV/m	dB	dBuV	dB	dB/m	dB	cm	deg		
1	4825.60	33.17	54.00	-20.83	27.49	7.65	31.11	33.08	125	275	Average	VERTICAL
2	4838.80	46.12	74.00	-27.88	40.44	7.65	31.11	33.08	125	275	Peak	VERTICAL

Temperature	26°C	Humidity	64%
Test Engineer	Gino Huang	Configurations	IEEE 802.11ac MCS0/Nss1 VHT40 CH 6 / Chain 1 + Chain 2 + Chain 3
Test Date	Apr. 14, 2016		

Horizontal

	Freq	Level	Limit	Over	Read	CableAntenna	Preamp	A/Pos	T/Pos	Remark	Pol/Phase
	MHz	dBuV/m	dBuV/m	dB	dBuV	Loss	Factor	cm	deg		
1	4869.00	45.43	74.00	-28.57	39.66	7.70	31.15	125	62	Peak	HORIZONTAL
2	4871.80	33.09	54.00	-20.91	27.32	7.70	31.15	125	62	Average	HORIZONTAL

Vertical

	Freq	Level	Limit	Over	Read	CableAntenna	Preamp	A/Pos	T/Pos	Remark	Pol/Phase
	MHz	dBuV/m	dBuV/m	dB	dBuV	Loss	Factor	cm	deg		
1	4871.00	34.54	54.00	-19.46	28.77	7.70	31.15	125	193	Average	VERTICAL
2	4873.20	47.68	74.00	-26.32	41.91	7.70	31.15	125	193	Peak	VERTICAL

Temperature	26°C	Humidity	64%
Test Engineer	Gino Huang	Configurations	IEEE 802.11ac MCS0/Nss1 VHT40 CH 9 / Chain 1 + Chain 2 + Chain 3
Test Date	Apr. 14, 2016		

Horizontal

	Freq	Level	Limit	Over	Read	Cable	Antenna	Preamp	A/Pos	T/Pos	Remark	Pol/Phase
	MHz	dBuV/m	dBuV/m	dB	dBuV	Loss	Factor	Factor	cm	deg		
1	4916.80	46.01	74.00	-27.99	40.13	7.75	31.20	33.07	125	82	Peak	HORIZONTAL
2	4918.50	33.29	54.00	-20.71	27.41	7.75	31.20	33.07	125	82	Average	HORIZONTAL

Vertical

	Freq	Level	Limit	Over	Read	Cable	Antenna	Preamp	A/Pos	T/Pos	Remark	Pol/Phase
	MHz	dBuV/m	dBuV/m	dB	dBuV	Loss	Factor	Factor	cm	deg		
1	4919.80	46.74	74.00	-27.26	40.86	7.75	31.20	33.07	125	232	Peak	VERTICAL
2	4923.70	34.37	54.00	-19.63	28.46	7.76	31.22	33.07	125	232	Average	VERTICAL

Note:

The amplitude of spurious emissions that are attenuated by more than 20dB below the permissible value has no need to be reported.

Emission level (dBuV/m) = 20 log Emission level (uV/m).

Corrected Reading: Antenna Factor + Cable Loss + Read Level - Preamp Factor = Level.

<For beamforming mode>

Temperature	26°C	Humidity	64%
Test Engineer	Gino Huang	Configurations	IEEE 802.11ac MCS0/Nss1 VHT20 CH 1 / Chain 1 + Chain 2 + Chain 3
Test Date	Apr. 16, 2016		

Horizontal

	Freq	Level	Limit	Over	Read	CableAntenna	Preamp	A/Pos	T/Pos	Remark	Pol/Phase
	MHz	dBuV/m	dBuV/m	dB	dBuV	dB	dB/m	dB	cm	deg	
1	4827.00	33.91	54.00	-20.09	28.23	7.65	31.11	33.08	250	118 Average	HORIZONTAL
2	4828.94	45.90	74.00	-28.10	40.22	7.65	31.11	33.08	250	118 Peak	HORIZONTAL

Vertical

	Freq	Level	Limit	Over	Read	CableAntenna	Preamp	A/Pos	T/Pos	Remark	Pol/Phase
	MHz	dBuV/m	dBuV/m	dB	dBuV	dB	dB/m	dB	cm	deg	
1	4819.80	46.01	74.00	-27.99	40.36	7.64	31.09	33.08	250	146 Peak	VERTICAL
2	4822.60	34.17	54.00	-19.83	28.52	7.64	31.09	33.08	250	146 Average	VERTICAL

Temperature	26°C	Humidity	64%
Test Engineer	Gino Huang	Configurations	IEEE 802.11ac MCS0/Nss1 VHT20 CH 6 / Chain 1 + Chain 2 + Chain 3
Test Date	Apr. 16, 2016		

Horizontal

	Freq	Level	Limit Line	Over Limit	Read Level	CableAntenna Loss	Antenna Factor	Preamp Factor	A/Pos	T/Pos	Remark	Pol/Phase
	MHz	dBuV/m	dBuV/m	dB	dBuV	dB	dB/m	dB	cm	deg		
1	4865.56	38.63	54.00	-15.37	32.89	7.68	31.14	33.08	250	257	Average	HORIZONTAL
2	4869.08	51.18	74.00	-22.82	45.41	7.70	31.15	33.08	250	257	Peak	HORIZONTAL
3	7317.84	39.93	54.00	-14.07	28.02	9.21	36.17	33.47	250	303	Average	HORIZONTAL
4	7320.04	52.71	74.00	-21.29	40.80	9.21	36.17	33.47	250	303	Peak	HORIZONTAL

Vertical

	Freq	Level	Limit Line	Over Limit	Read Level	CableAntenna Loss	Antenna Factor	Preamp Factor	A/Pos	T/Pos	Remark	Pol/Phase
	MHz	dBuV/m	dBuV/m	dB	dBuV	dB	dB/m	dB	cm	deg		
1	4869.32	47.04	74.00	-26.96	41.27	7.70	31.15	33.08	250	192	Peak	VERTICAL
2	4873.80	39.13	54.00	-14.87	33.36	7.70	31.15	33.08	250	140	Average	VERTICAL
3	7301.24	43.13	54.00	-10.87	31.27	9.22	36.11	33.47	250	335	Average	VERTICAL
4	7304.36	52.97	74.00	-21.03	41.11	9.22	36.11	33.47	250	335	Peak	VERTICAL

Temperature	26°C	Humidity	64%
Test Engineer	Gino Huang	Configurations	IEEE 802.11ac MCS0/Nss1 VHT20 CH 11 / Chain 1 + Chain 2 + Chain 3
Test Date	Apr. 16, 2016		

Horizontal

	Freq	Level	Limit Line	Over Limit	Read Level	CableAntenna Loss	Antenna Factor	Preamp Factor	A/Pos	T/Pos	Remark	Pol/Phase
	MHz	dBuV/m	dBuV/m	dB	dBuV	dB	dB/m	dB	cm	deg		
1	4923.84	45.40	74.00	-28.60	39.49	7.76	31.22	33.07	250	72	Peak	HORIZONTAL
2	4925.12	33.60	54.00	-20.40	27.68	7.76	31.22	33.06	250	72	Average	HORIZONTAL
3	7382.60	39.79	54.00	-14.21	27.78	9.17	36.33	33.49	250	91	Average	HORIZONTAL
4	7387.24	52.06	74.00	-21.94	40.05	9.17	36.33	33.49	250	91	Peak	HORIZONTAL

Vertical

	Freq	Level	Limit Line	Over Limit	Read Level	CableAntenna Loss	Antenna Factor	Preamp Factor	A/Pos	T/Pos	Remark	Pol/Phase
	MHz	dBuV/m	dBuV/m	dB	dBuV	dB	dB/m	dB	cm	deg		
1	4920.40	33.35	54.00	-20.65	27.47	7.75	31.20	33.07	250	123	Average	VERTICAL
2	4932.84	46.46	74.00	-27.54	40.54	7.76	31.22	33.06	250	123	Peak	VERTICAL
3	7381.76	52.04	74.00	-21.96	40.03	9.17	36.33	33.49	250	42	Peak	VERTICAL
4	7395.32	39.93	54.00	-14.07	27.92	9.17	36.33	33.49	250	42	Average	VERTICAL

Temperature	26°C	Humidity	64%
Test Engineer	Gino Huang	Configurations	IEEE 802.11ac MCS0/Nss1 VHT40 CH 3 / Chain 1 + Chain 2 + Chain 3
Test Date	Apr. 16, 2016		

Horizontal

	Freq	Level	Limit Line	Over Limit	Read Level	CableAntenna Loss	Antenna Factor	Preamp Factor	A/Pos	T/Pos	Remark	Pol/Phase
	MHz	dBuV/m	dBuV/m	dB	dBuV	dB	dB/m	dB	cm	deg		
1	4840.04	46.41	74.00	-27.59	40.70	7.67	31.12	33.08	250	244	Peak	HORIZONTAL
2	4848.14	32.83	54.00	-21.17	27.12	7.67	31.12	33.08	250	244	Average	HORIZONTAL

Vertical

	Freq	Level	Limit Line	Over Limit	Read Level	CableAntenna Loss	Antenna Factor	Preamp Factor	A/Pos	T/Pos	Remark	Pol/Phase
	MHz	dBuV/m	dBuV/m	dB	dBuV	dB	dB/m	dB	cm	deg		
1	4845.20	32.89	54.00	-21.11	27.18	7.67	31.12	33.08	250	194	Average	VERTICAL
2	4845.86	45.88	74.00	-28.12	40.17	7.67	31.12	33.08	250	194	Peak	VERTICAL

Temperature	26°C	Humidity	64%
Test Engineer	Gino Huang	Configurations	IEEE 802.11ac MCS0/Nss1 VHT40 CH 6 / Chain 1 + Chain 2 + Chain 3
Test Date	Apr. 16, 2016		

Horizontal

	Freq	Level	Limit Line	Over Limit	Read Level	CableAntenna Loss	Antenna Factor	Preamp Factor	A/Pos	T/Pos	Remark	Pol/Phase
	MHz	dBuV/m	dBuV/m	dB	dBuV	dB	dB/m	dB	cm	deg		
1	4870.18	39.93	54.00	-14.07	34.16	7.70	31.15	33.08	250	95	Average	HORIZONTAL
2	4871.84	52.70	74.00	-21.30	46.93	7.70	31.15	33.08	250	95	Peak	HORIZONTAL
3	7308.18	52.42	74.00	-21.58	40.56	9.22	36.11	33.47	250	174	Peak	HORIZONTAL
4	7310.54	39.32	54.00	-14.68	27.46	9.22	36.11	33.47	250	174	Average	HORIZONTAL

Vertical

	Freq	Level	Limit Line	Over Limit	Read Level	CableAntenna Loss	Antenna Factor	Preamp Factor	A/Pos	T/Pos	Remark	Pol/Phase
	MHz	dBuV/m	dBuV/m	dB	dBuV	dB	dB/m	dB	cm	deg		
1	4875.32	36.65	54.00	-17.35	30.88	7.70	31.15	33.08	250	244	Average	VERTICAL
2	4877.08	51.28	74.00	-22.72	45.50	7.70	31.15	33.07	250	244	Peak	VERTICAL
3	7309.04	52.03	74.00	-21.97	40.17	9.22	36.11	33.47	250	288	Peak	VERTICAL
4	7314.64	40.28	54.00	-13.72	28.42	9.22	36.11	33.47	250	288	Average	VERTICAL

Temperature	26°C	Humidity	64%
Test Engineer	Gino Huang	Configurations	IEEE 802.11ac MCS0/Nss1 VHT20 CH 9 / Chain 1 + Chain 2 + Chain 3
Test Date	Apr. 16, 2016		

Horizontal

	Freq	Level	Limit	Over	Read	CableAntenna	Preamp	A/Pos	T/Pos	Remark	Pol/Phase
	MHz	dBuV/m	dBuV/m	dB	dBuV	dB	dB/m	dB	cm	deg	
1	4901.90	33.19	54.00	-20.81	27.34	7.73	31.19	33.07	250	106 Average	HORIZONTAL
2	4906.64	45.71	74.00	-28.29	39.86	7.73	31.19	33.07	250	106 Peak	HORIZONTAL
3	7354.40	52.51	74.00	-21.49	40.57	9.20	36.22	33.48	250	49 Peak	HORIZONTAL
4	7355.70	39.57	54.00	-14.43	27.63	9.20	36.22	33.48	250	49 Average	HORIZONTAL

Vertical

	Freq	Level	Limit	Over	Read	CableAntenna	Preamp	A/Pos	T/Pos	Remark	Pol/Phase
	MHz	dBuV/m	dBuV/m	dB	dBuV	dB	dB/m	dB	cm	deg	
1	4900.48	33.10	54.00	-20.90	27.25	7.73	31.19	33.07	250	63 Average	VERTICAL
2	4908.52	45.52	74.00	-28.48	39.67	7.73	31.19	33.07	250	63 Peak	VERTICAL
3	7354.30	40.01	54.00	-13.99	28.07	9.20	36.22	33.48	250	18 Average	VERTICAL
4	7355.24	53.32	74.00	-20.68	41.38	9.20	36.22	33.48	250	18 Peak	VERTICAL

Note:

The amplitude of spurious emissions that are attenuated by more than 20dB below the permissible value has no need to be reported.

Emission level (dBuV/m) = 20 log Emission level (uV/m).

Corrected Reading: Antenna Factor + Cable Loss + Read Level - Preamp Factor = Level.

4.6. Emissions Measurement

4.6.1. Limit

30dBc in any 100 kHz bandwidth outside the operating frequency band. In case the emission fall within the restricted band specified on 15.205(a), then the 15.209(a) limit in the table below has to be followed.

Frequencies (MHz)	Field Strength (micovolts/meter)	Measurement Distance (meters)
0.009~0.490	2400/F(kHz)	300
0.490~1.705	24000/F(kHz)	30
1.705~30.0	30	30
30~88	100	3
88~216	150	3
216~960	200	3
Above 960	500	3

4.6.2. Measuring Instruments and Setting

Please refer to section 5 of equipments list in this report. The following table is the setting of the spectrum analyzer.

Spectrum Parameter	Setting
Attenuation	Auto
Span Frequency	100 MHz
RBW / VBW (Emission in restricted band)	1 MHz / 3MHz for Peak, 1 MHz / 1/T for Average
RBW / VBW (30dBc in any 100 kHz bandwidth emission)	100 kHz / 300 kHz for Peak

4.6.3. Test Procedures

For Radiated band edges Measurement:

1. The test procedure is the same as section 4.5.3.

For Radiated Out of Band Emission Measurement:

1. Test was performed in accordance with KDB558074 D01 v03r05 for Performing Compliance Measurements on Digital Transmission Systems (DTS) Operating Under §15.247 section 11.0 Unwanted Emissions into Non-Restricted Frequency Bands Measurement Procedure

4.6.4. Test Setup Layout

For Radiated band edges Measurement:

This test setup layout is the same as that shown in section 4.5.4.

For Radiated Out of Band Emission Measurement:

This test setup layout is the same as that shown in section 4.5.4.

4.6.5. Test Deviation

There is no deviation with the original standard.

4.6.6. EUT Operation during Test

For non-beamforming mode:

The EUT was programmed to be in continuously transmitting mode.

For beamforming mode:

The EUT was programmed to be in beamforming transmitting mode.

4.6.7. Test Result of Band Edge and Fundamental Emissions

<For non-beamforming mode>

Temperature	26°C	Humidity	64%
Test Engineer	Gino Huang	Configurations	IEEE 802.11b CH 1, 6, 11 / Chain 1 + Chain 2 + Chain 3
Test Date	Apr. 13, 2016		

Channel 1

	Freq	Level	Limit	Over	Read	CableAntenna	Preamp	A/Pos	T/Pos	Remark	Pol/Phase
	MHz	dBuV/m	dBuV/m	dB	dBuV	dB	dB/m	dB	cm	deg	
1	2390.00	48.71	54.00	-5.29	16.25	5.23	27.23	0.00	105	189 Average	VERTICAL
2	2390.00	60.59	74.00	-13.41	28.13	5.23	27.23	0.00	105	189 Peak	VERTICAL
3	2412.80	118.66			86.09	5.27	27.30	0.00	105	189 Average	VERTICAL
4	2413.20	122.70			90.13	5.27	27.30	0.00	105	189 Peak	VERTICAL
5	2488.00	59.73	74.00	-14.27	26.92	5.34	27.47	0.00	105	189 Peak	VERTICAL
6	2489.60	48.22	54.00	-5.78	15.39	5.35	27.48	0.00	105	189 Average	VERTICAL

Item 3, 4 are the fundamental frequency at 2412 MHz.

Channel 6

	Freq	Level	Limit	Over	Read	CableAntenna	Preamp	A/Pos	T/Pos	Remark	Pol/Phase
	MHz	dBuV/m	dBuV/m	dB	dBuV	dB	dB/m	dB	cm	deg	
1	2387.20	58.44	74.00	-15.56	25.98	5.23	27.23	0.00	126	189 Peak	VERTICAL
2	2389.80	46.78	54.00	-7.22	14.32	5.23	27.23	0.00	126	189 Average	VERTICAL
3	2437.80	119.47			86.83	5.29	27.35	0.00	126	189 Average	VERTICAL
4	2438.20	123.52			90.88	5.29	27.35	0.00	126	189 Peak	VERTICAL
5	2483.50	48.13	54.00	-5.87	15.32	5.34	27.47	0.00	126	189 Average	VERTICAL
6	2488.70	60.28	74.00	-13.72	27.47	5.34	27.47	0.00	126	189 Peak	VERTICAL

Item 3, 4 are the fundamental frequency at 2437 MHz.

Channel 11

	Freq	Level	Limit	Over	Read	CableAntenna	Preamp	A/Pos	T/Pos	Remark	Pol/Phase
	MHz	dBuV/m	dBuV/m	dB	dBuV	dB	dB/m	dB	cm	deg	
1	2383.60	49.01	54.00	-4.99	16.55	5.23	27.23	0.00	125	186 Average	VERTICAL
2	2383.60	60.54	74.00	-13.46	28.08	5.23	27.23	0.00	125	186 Peak	VERTICAL
3	2461.20	118.63			85.89	5.32	27.42	0.00	125	186 Average	VERTICAL
4	2463.20	122.64			89.90	5.32	27.42	0.00	125	186 Peak	VERTICAL
5	2483.50	52.90	54.00	-1.10	20.09	5.34	27.47	0.00	125	186 Average	VERTICAL
6	2483.90	62.69	74.00	-11.31	29.88	5.34	27.47	0.00	125	186 Peak	VERTICAL

Item 3, 4 are the fundamental frequency at 2462 MHz.

Temperature	26°C	Humidity	64%
Test Engineer	Gino Huang	Configurations	IEEE 802.11g CH 1, 6, 11 / Chain 1 + Chain 2 + Chain 3
Test Date	Apr. 13, 2016		

Channel 1

	Freq	Level	Limit	Over	Read	CableAntenna	Preamp	A/Pos	T/Pos	Remark	Pol/Phase
	MHz	dBuV/m	dBuV/m	dB	dBuV	dB	dB/m	dB	cm	deg	
1	2390.00	52.70	54.00	-1.30	20.24	5.23	27.23	0.00	100	182 Average	VERTICAL
2	2390.00	67.69	74.00	-6.31	35.23	5.23	27.23	0.00	100	182 Peak	VERTICAL
3	2411.20	108.53			75.96	5.27	27.30	0.00	100	182 Average	VERTICAL
4	2411.40	118.80			86.23	5.27	27.30	0.00	100	182 Peak	VERTICAL

Item 3, 4 are the fundamental frequency at 2412 MHz.

Channel 6

	Freq	Level	Limit	Over	Read	CableAntenna	Preamp	A/Pos	T/Pos	Remark	Pol/Phase
	MHz	dBuV/m	dBuV/m	dB	dBuV	dB	dB/m	dB	cm	deg	
1	2388.80	46.66	54.00	-7.34	14.20	5.23	27.23	0.00	100	193 Average	VERTICAL
2	2389.00	58.52	74.00	-15.48	26.06	5.23	27.23	0.00	100	193 Peak	VERTICAL
3	2437.80	112.27			79.63	5.29	27.35	0.00	100	193 Average	VERTICAL
4	2438.20	122.62			89.98	5.29	27.35	0.00	100	193 Peak	VERTICAL
5	2483.50	47.56	54.00	-6.44	14.75	5.34	27.47	0.00	100	193 Average	VERTICAL
6	2489.80	60.06	74.00	-13.94	27.23	5.35	27.48	0.00	100	193 Peak	VERTICAL

Item 3, 4 are the fundamental frequency at 2437 MHz.

Channel 11

	Freq	Level	Limit	Over	Read	CableAntenna	Preamp	A/Pos	T/Pos	Remark	Pol/Phase
	MHz	dBuV/m	dBuV/m	dB	dBuV	dB	dB/m	dB	cm	deg	
1	2461.00	119.02			86.28	5.32	27.42	0.00	100	180 Peak	VERTICAL
2	2461.20	108.38			75.64	5.32	27.42	0.00	100	180 Average	VERTICAL
3	2483.50	52.70	54.00	-1.30	19.89	5.34	27.47	0.00	100	180 Average	VERTICAL
4	2484.20	71.83	74.00	-2.17	39.02	5.34	27.47	0.00	100	180 Peak	VERTICAL

Item 1, 2 are the fundamental frequency at 2462 MHz.

Temperature	26°C	Humidity	64%
Test Engineer	Gino Huang	Configurations	IEEE 802.11ac MCS0/Nss1 VHT20 CH 1, 6, 11 / Chain 1 + Chain 2 + Chain 3
Test date	Apr. 13, 2016		

Channel 1

	Freq	Level	Limit	Over	Read	CableAntenna	Preamp	A/Pos	T/Pos	Remark	Pol/Phase
	MHz	dBuV/m	dBuV/m	dB	dBuV	dB	dB/m	dB	cm	deg	
1	2387.60	72.00	74.00	-2.00	39.54	5.23	27.23	0.00	300	188 Peak	VERTICAL
2	2390.00	52.99	54.00	-1.01	20.53	5.23	27.23	0.00	300	188 Average	VERTICAL
3	2407.20	118.38			85.84	5.26	27.28	0.00	300	188 Peak	VERTICAL
4	2411.60	107.36			74.79	5.27	27.30	0.00	300	188 Average	VERTICAL

Item 3, 4 are the fundamental frequency at 2412 MHz.

Channel 6

	Freq	Level	Limit	Over	Read	CableAntenna	Preamp	A/Pos	T/Pos	Remark	Pol/Phase
	MHz	dBuV/m	dBuV/m	dB	dBuV	dB	dB/m	dB	cm	deg	
1	2389.40	57.39	74.00	-16.61	24.93	5.23	27.23	0.00	100	187 Peak	VERTICAL
2	2390.00	46.61	54.00	-7.39	14.15	5.23	27.23	0.00	100	187 Average	VERTICAL
3	2431.80	121.43			88.82	5.28	27.33	0.00	100	187 Peak	VERTICAL
4	2441.80	111.16			78.50	5.30	27.36	0.00	100	187 Average	VERTICAL
5	2483.50	48.18	54.00	-5.82	15.37	5.34	27.47	0.00	100	187 Average	VERTICAL
6	2485.40	63.75	74.00	-10.25	30.94	5.34	27.47	0.00	100	187 Peak	VERTICAL

Item 3, 4 are the fundamental frequency at 2437 MHz.

Channel 11

	Freq	Level	Limit	Over	Read	CableAntenna	Preamp	A/Pos	T/Pos	Remark	Pol/Phase
	MHz	dBuV/m	dBuV/m	dB	dBuV	dB	dB/m	dB	cm	deg	
1	2460.80	117.74			85.00	5.32	27.42	0.00	125	186 Peak	VERTICAL
2	2461.60	106.31			73.57	5.32	27.42	0.00	125	186 Average	VERTICAL
3	2483.50	52.86	54.00	-1.14	20.05	5.34	27.47	0.00	125	186 Average	VERTICAL
4	2483.50	71.03	74.00	-2.97	38.22	5.34	27.47	0.00	125	186 Peak	VERTICAL

Item 1, 2 are the fundamental frequency at 2462 MHz.

Temperature	26°C	Humidity	64%
Test Engineer	Gino Huang	Configurations	IEEE 802.11ac MCS0/NSS1 VHT40 CH 3, 6, 9 / Chain 1 + Chain 2 + Chain 3
Test date	Apr. 13, 2016		

Channel 3

	Freq	Level	Limit	Over	Read	CableAntenna	Preamp	A/Pos	T/Pos	Remark	Pol/Phase
	MHz	dBuV/m	dBuV/m	dB	dBuV	dB	dB/m	dB	cm	deg	
1	2387.20	52.38	54.00	-1.62	19.92	5.23	27.23	0.00	250	184 Average	VERTICAL
2	2390.00	68.47	74.00	-5.53	36.01	5.23	27.23	0.00	250	184 Peak	VERTICAL
3	2426.80	103.57			70.96	5.28	27.33	0.00	250	184 Average	VERTICAL
4	2426.80	113.14			80.53	5.28	27.33	0.00	250	184 Peak	VERTICAL

Item 3, 4 are the fundamental frequency at 2422 MHz.

Channel 6

	Freq	Level	Limit	Over	Read	CableAntenna	Preamp	A/Pos	T/Pos	Remark	Pol/Phase
	MHz	dBuV/m	dBuV/m	dB	dBuV	dB	dB/m	dB	cm	deg	
1	2389.60	59.53	74.00	-14.47	27.07	5.23	27.23	0.00	298	189 Peak	VERTICAL
2	2390.00	48.18	54.00	-5.82	15.72	5.23	27.23	0.00	298	189 Average	VERTICAL
3	2432.20	104.95			72.31	5.29	27.35	0.00	298	189 Average	VERTICAL
4	2442.40	115.40			82.74	5.30	27.36	0.00	298	189 Peak	VERTICAL
5	2483.50	52.57	54.00	-1.43	19.76	5.34	27.47	0.00	298	189 Average	VERTICAL
6	2487.40	66.04	74.00	-7.96	33.23	5.34	27.47	0.00	298	189 Peak	VERTICAL

Item 3, 4 are the fundamental frequency at 2437 MHz.

Channel 9

	Freq	Level	Limit	Over	Read	CableAntenna	Preamp	A/Pos	T/Pos	Remark	Pol/Phase
	MHz	dBuV/m	dBuV/m	dB	dBuV	dB	dB/m	dB	cm	deg	
1	2447.20	101.36			68.68	5.30	27.38	0.00	298	189 Average	VERTICAL
2	2447.20	111.05			78.37	5.30	27.38	0.00	298	189 Peak	VERTICAL
3	2486.80	52.92	54.00	-1.08	20.11	5.34	27.47	0.00	298	189 Average	VERTICAL
4	2487.40	65.81	74.00	-8.19	33.00	5.34	27.47	0.00	298	189 Peak	VERTICAL

Item 1, 2 are the fundamental frequency at 2452 MHz.

Note:

Emission level (dBuV/m) = 20 log Emission level (uV/m).

Corrected Reading: Antenna Factor + Cable Loss + Read Level - Preamp Factor = Level.

<For beamforming mode>

Temperature	26°C	Humidity	64%
Test Engineer	Gino Huang	Configurations	IEEE 802.11ac MCS0/Nss1 VHT20 CH 1, 6, 11 / Chain 1 + Chain 2 + Chain 3
Test date	Apr. 15, 2016		

Channel 1

	Freq	Level	Limit	Over	Read	CableAntenna	Preamp	A/Pos	T/Pos	Remark	Pol/Phase	
	MHz	dBuV/m	dBuV/m	dB	dBuV	dB	dB/m	dB	cm	deg		
1	2390.00	52.97	54.00	-1.03	21.11	4.63	27.23	0.00	251	181	Average	VERTICAL
2	2390.00	67.98	74.00	-6.02	36.12	4.63	27.23	0.00	251	181	Peak	VERTICAL
3	2405.40	104.87			72.94	4.65	27.28	0.00	251	181	Average	VERTICAL
4	2410.00	114.23			82.30	4.65	27.28	0.00	251	181	Peak	VERTICAL

Item 3, 4 are the fundamental frequency at 2412 MHz.

Channel 6

	Freq	Level	Limit	Over	Read	CableAntenna	Preamp	A/Pos	T/Pos	Remark	Pol/Phase	
	MHz	dBuV/m	dBuV/m	dB	dBuV	dB	dB/m	dB	cm	deg		
1	2385.80	58.09	74.00	-15.91	26.23	4.63	27.23	0.00	251	101	Peak	VERTICAL
2	2390.00	46.92	54.00	-7.08	15.06	4.63	27.23	0.00	251	101	Average	VERTICAL
3	2436.20	120.82			88.79	4.68	27.35	0.00	251	101	Peak	VERTICAL
4	2436.60	111.99			79.96	4.68	27.35	0.00	251	101	Average	VERTICAL
5	2485.40	47.40	54.00	-6.60	15.20	4.73	27.47	0.00	251	101	Average	VERTICAL
6	2486.20	58.92	74.00	-15.08	26.72	4.73	27.47	0.00	251	101	Peak	VERTICAL

Item 3, 4 are the fundamental frequency at 2437 MHz.

Channel 11

	Freq	Level	Limit	Over	Read	CableAntenna	Preamp	A/Pos	T/Pos	Remark	Pol/Phase	
	MHz	dBuV/m	dBuV/m	dB	dBuV	dB	dB/m	dB	cm	deg		
1	2463.60	116.00			83.87	4.71	27.42	0.00	250	81	Peak	VERTICAL
2	2464.40	106.48			74.35	4.71	27.42	0.00	250	81	Average	VERTICAL
3	2483.50	52.98	54.00	-1.02	20.78	4.73	27.47	0.00	250	81	Average	VERTICAL
4	2483.50	68.22	74.00	-5.78	36.02	4.73	27.47	0.00	250	81	Peak	VERTICAL

Item 1, 2 are the fundamental frequency at 2462 MHz.

Temperature	26°C	Humidity	64%
Test Engineer	Gino Huang	Configurations	IEEE 802.11ac MCS0/NSS1 VHT40 CH 3, 6, 9 / Chain 1 + Chain 2 + Chain 3
Test date	Apr. 15, 2016		

Channel 3

	Freq	Level	Limit	Over	Read	CableAntenna	Preamp	A/Pos	T/Pos	Remark	Pol/Phase
	MHz	dBuV/m	dBuV/m	dB	dBuV	dB	dB/m	dB	cm	deg	
1	2390.00	52.96	54.00	-1.04	21.10	4.63	27.23	0.00	251	174 Average	VERTICAL
2	2390.00	66.87	74.00	-7.13	35.01	4.63	27.23	0.00	251	174 Peak	VERTICAL
3	2416.40	101.30			69.34	4.66	27.30	0.00	251	174 Average	VERTICAL
4	2417.60	110.24			78.28	4.66	27.30	0.00	251	174 Peak	VERTICAL

Item 3, 4 are the fundamental frequency at 2422 MHz.

Channel 6

	Freq	Level	Limit	Over	Read	CableAntenna	Preamp	A/Pos	T/Pos	Remark	Pol/Phase
	MHz	dBuV/m	dBuV/m	dB	dBuV	dB	dB/m	dB	cm	deg	
1	2390.00	49.69	54.00	-4.31	17.83	4.63	27.23	0.00	264	91 Average	VERTICAL
2	2390.00	60.99	74.00	-13.01	29.13	4.63	27.23	0.00	264	91 Peak	VERTICAL
3	2441.40	103.24			71.19	4.69	27.36	0.00	264	91 Average	VERTICAL
4	2441.40	113.19			81.14	4.69	27.36	0.00	264	91 Peak	VERTICAL
5	2483.50	52.77	54.00	-1.23	20.57	4.73	27.47	0.00	264	91 Average	VERTICAL
6	2484.20	66.80	74.00	-7.20	34.60	4.73	27.47	0.00	264	91 Peak	VERTICAL

Item 3, 4 are the fundamental frequency at 2437 MHz.

Channel 9

	Freq	Level	Limit	Over	Read	CableAntenna	Preamp	A/Pos	T/Pos	Remark	Pol/Phase
	MHz	dBuV/m	dBuV/m	dB	dBuV	dB	dB/m	dB	cm	deg	
1	2438.40	109.77			77.74	4.68	27.35	0.00	238	87 Peak	VERTICAL
2	2439.20	100.77			68.74	4.68	27.35	0.00	238	87 Average	VERTICAL
3	2484.40	52.93	54.00	-1.07	20.73	4.73	27.47	0.00	238	87 Average	VERTICAL
4	2484.40	66.45	74.00	-7.55	34.25	4.73	27.47	0.00	238	87 Peak	VERTICAL

Item 1, 2 are the fundamental frequency at 2452 MHz.

Note:

Emission level (dBuV/m) = 20 log Emission level (uV/m).

Corrected Reading: Antenna Factor + Cable Loss + Read Level - Preamp Factor = Level.

For Emission not in Restricted Band

<For non-beamforming mode>

Plot on Configuration IEEE 802.11b / Reference Level

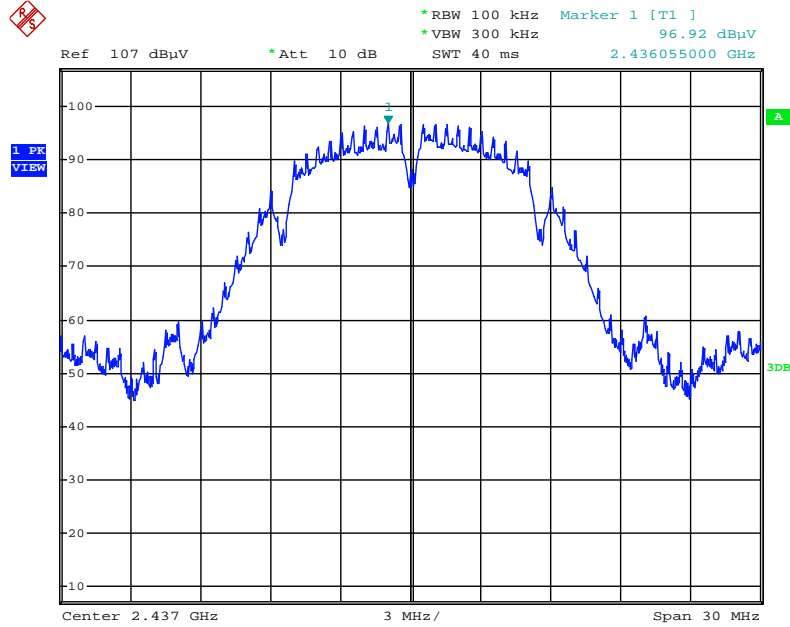

Date: 14.APR.2016 01:48:22

Plot on Configuration IEEE 802.11b / CH 1 / 30MHz~2400MHz (down 30dBc)

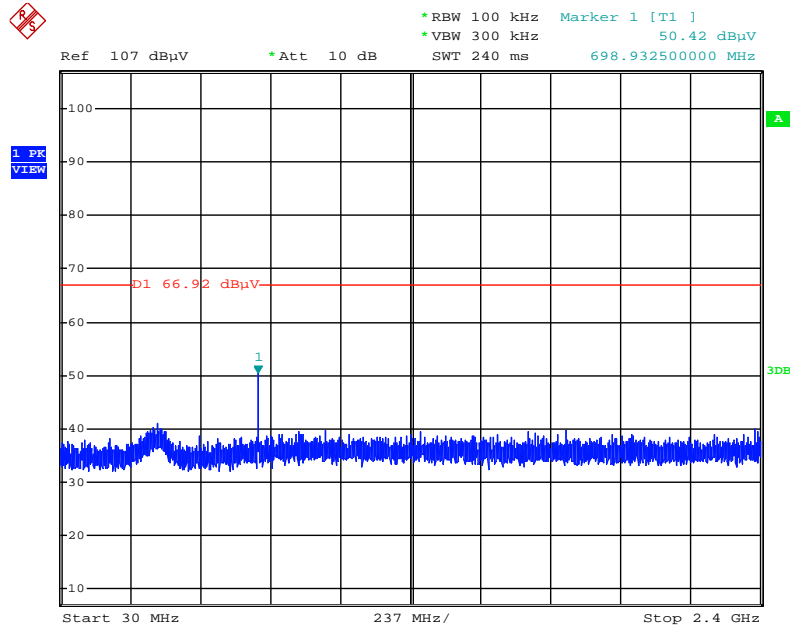

Date: 14.APR.2016 01:49:20

Plot on Configuration IEEE 802.11b / CH 1 / 2483.5MHz~26500MHz (down 30dBc)

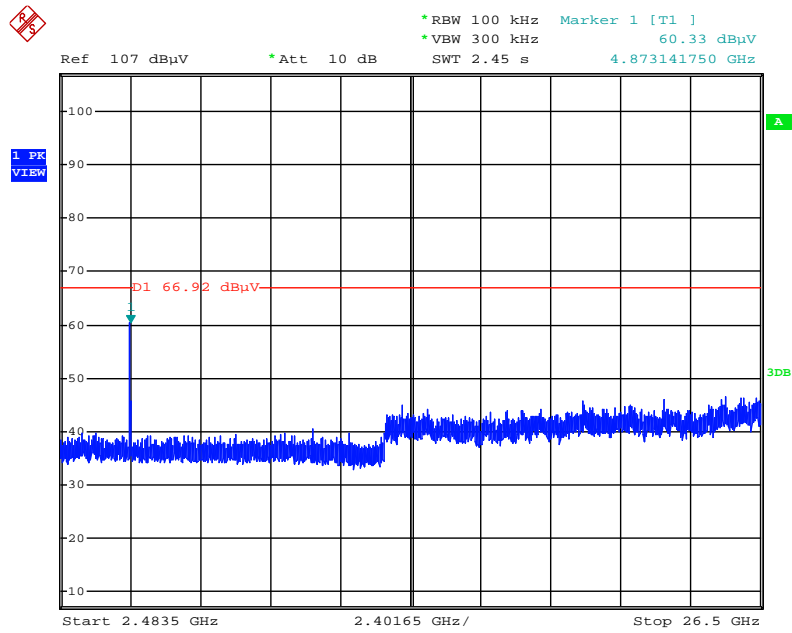

Date: 14.APR.2016 01:49:53

Plot on Configuration IEEE 802.11b / CH 11 / 30MHz~2400MHz (down 30dBc)

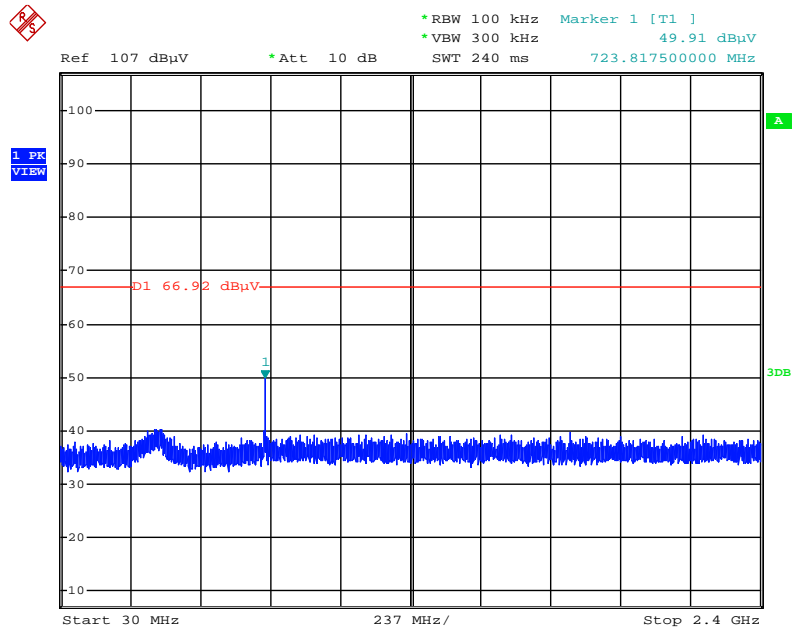

Date: 14.APR.2016 01:50:54

Plot on Configuration IEEE 802.11b / CH 11 / 2483.5MHz~26500MHz (down 30dBc)

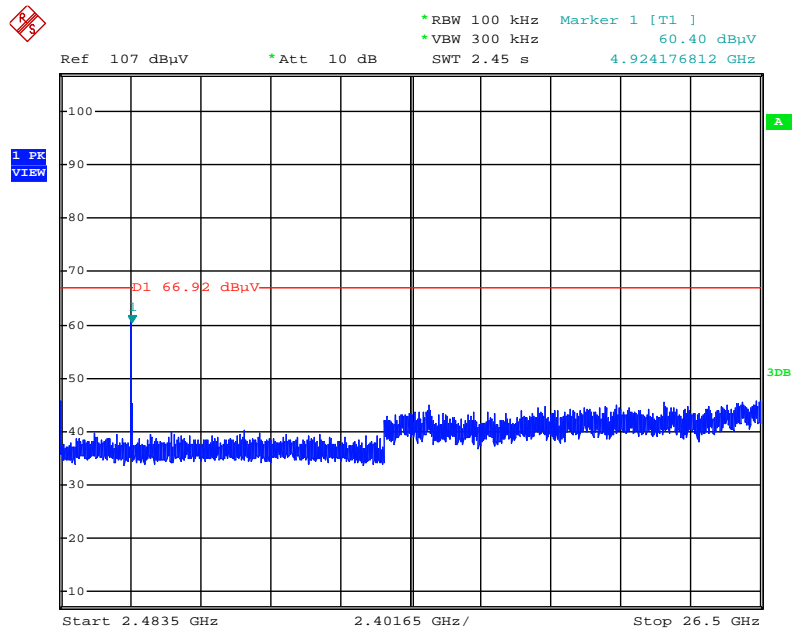

Date: 14.APR.2016 01:50:28

Plot on Configuration IEEE 802.11g / Reference Level

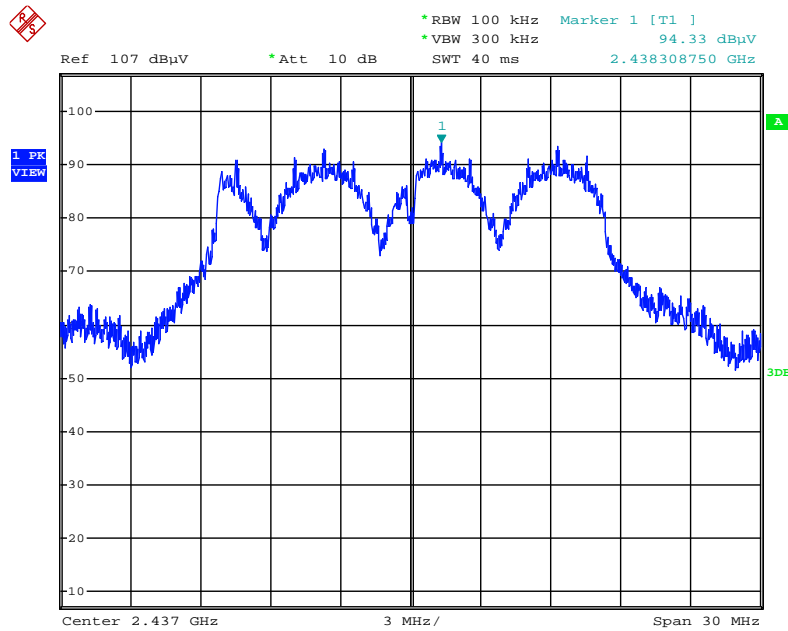

Date: 14.APR.2016 01:52:19

Plot on Configuration IEEE 802.11g / CH 1 / 30MHz~2400MHz (down 30dBc)

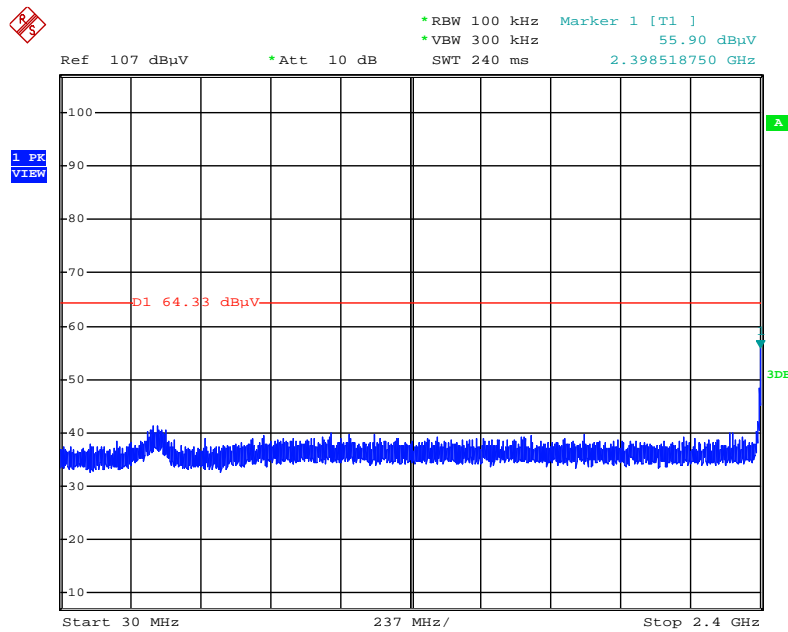

Date: 14.APR.2016 01:53:20

Plot on Configuration IEEE 802.11g / CH 1 / 2483.5MHz~26500MHz (down 30dBc)

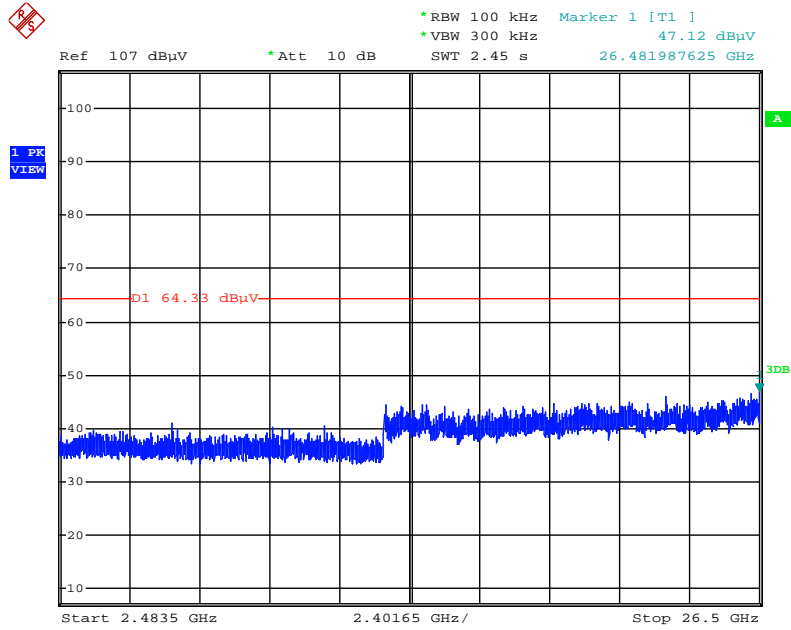

Date: 14.APR.2016 01:53:48

Plot on Configuration IEEE 802.11g / CH 11 / 30MHz~2400MHz (down 30dBc)

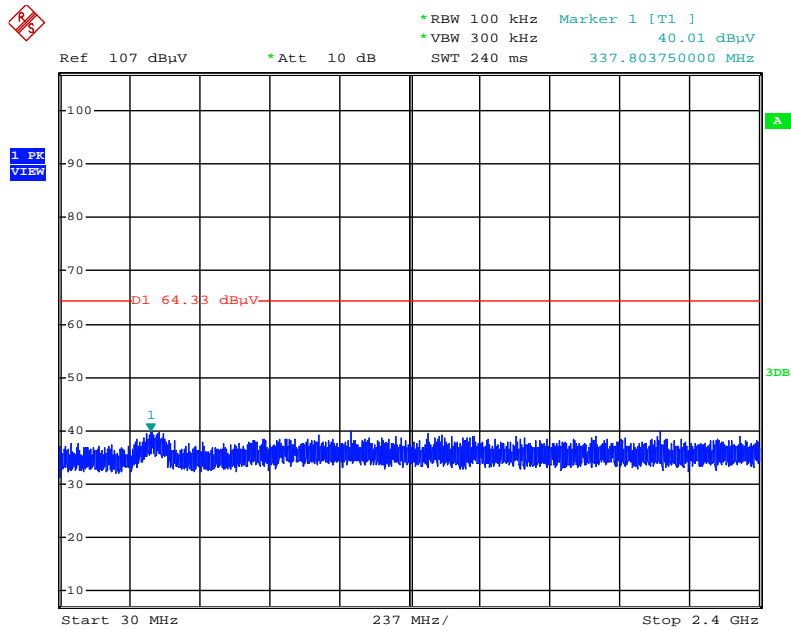

Date: 14.APR.2016 01:54:50

Plot on Configuration IEEE 802.11g / CH 11 / 2483.5MHz~26500MHz (down 30dBc)

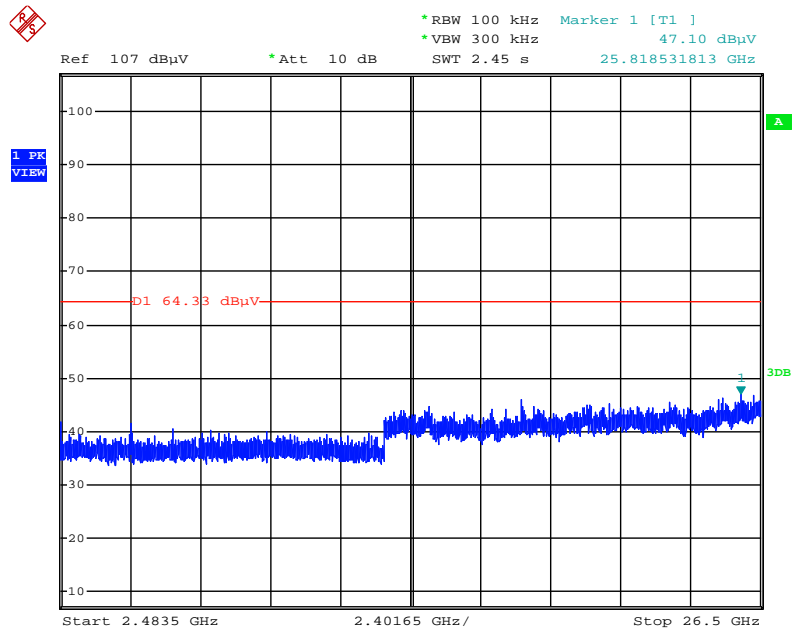

Date: 14.APR.2016 01:54:28

Plot on Configuration IEEE 802.11ac MCS0/Nss1 VHT20 / Reference Level

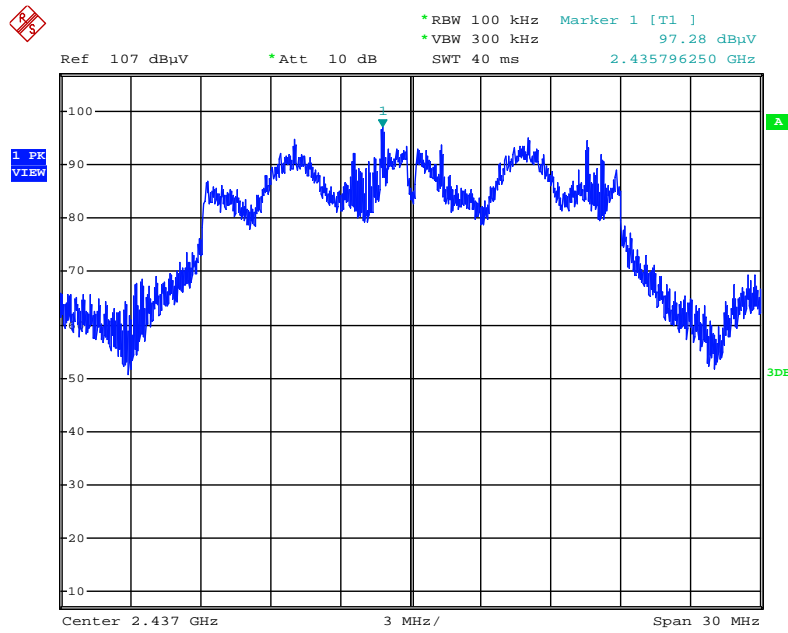

Date: 14.APR.2016 01:56:21

Plot on Configuration IEEE 802.11ac MCS0/Nss1 VHT20 / CH 1 / 30MHz~2400MHz (down 30dBc)

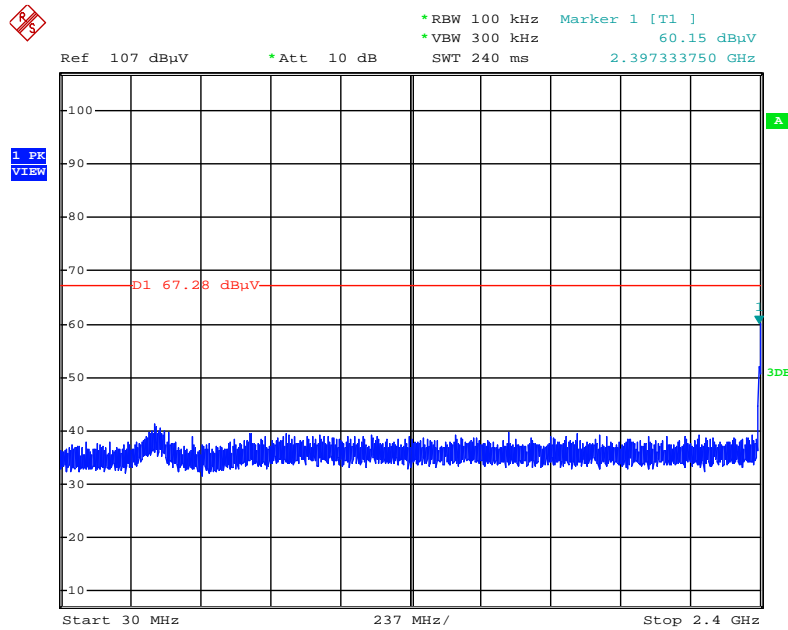

Date: 14.APR.2016 01:57:49

Plot on Configuration IEEE 802.11ac MCS0/Nss1 VHT20 / CH 1 / 2483.5MHz~26500MHz (down 30dBc)

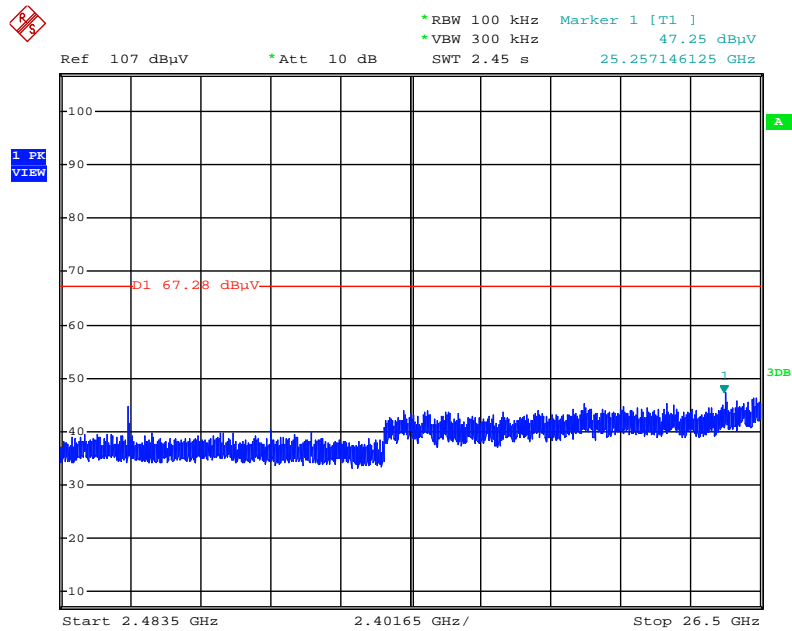

Date: 14.APR.2016 01:58:14

Plot on Configuration IEEE 802.11ac MCS0/Nss1 VHT20 / CH 11 / 30MHz~2400MHz (down 30dBc)

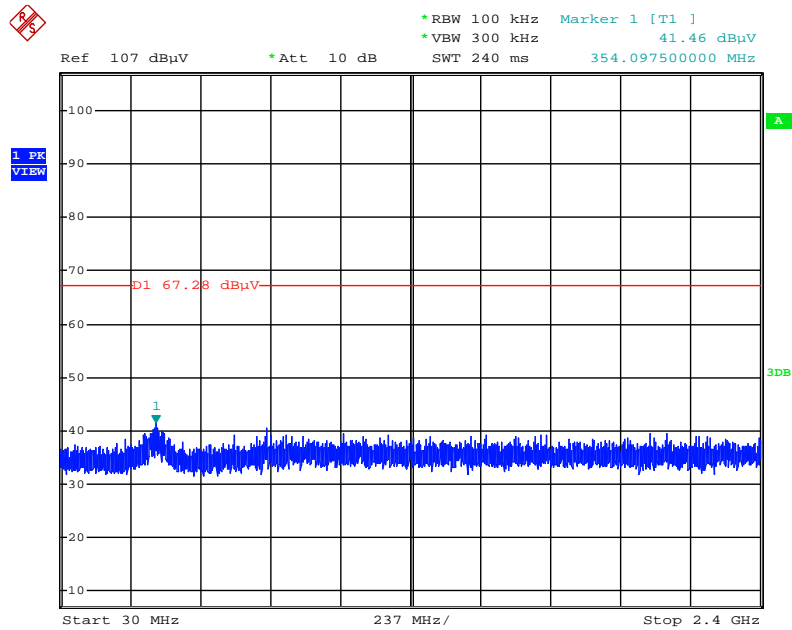

Date: 14.APR.2016 01:59:06

Plot on Configuration IEEE 802.11ac MCS0/Nss1 VHT20 / CH 11 / 2483.5MHz~26500MHz (down 30dBc)

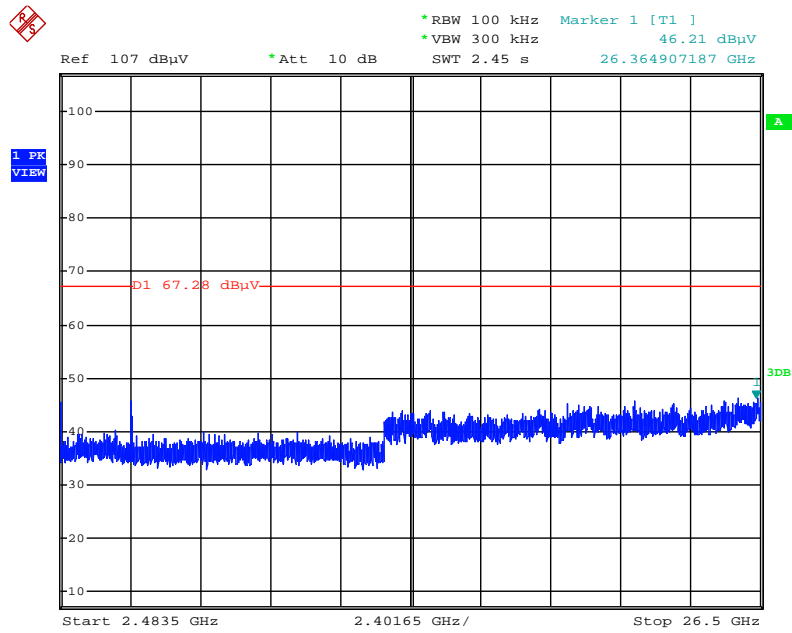

Date: 14.APR.2016 01:58:42

Plot on Configuration IEEE 802.11ac MCS0/NSS1 VHT40 / Reference Level

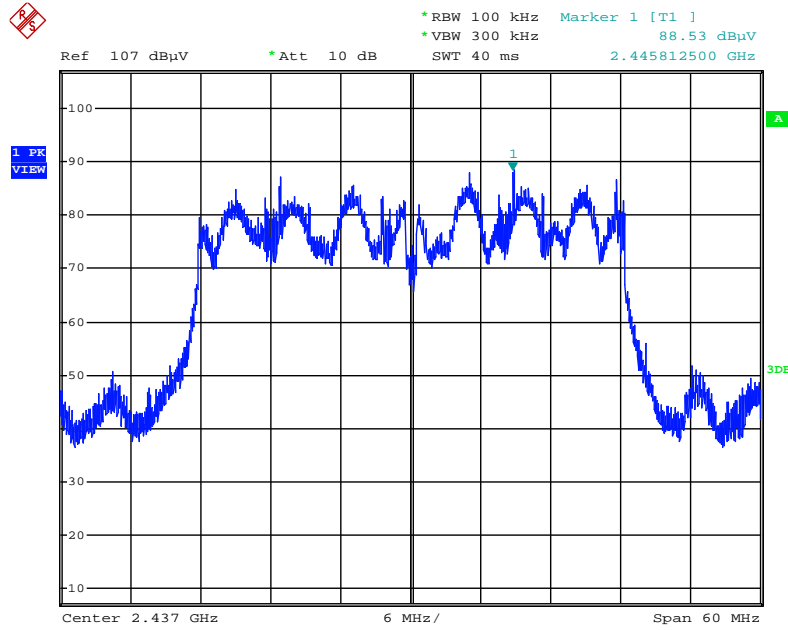

Date: 14.APR.2016 02:00:37

Plot on Configuration IEEE 802.11ac MCS0/NSS1 VHT40 / CH 3 / 30MHz~2400MHz (down 30dBc)

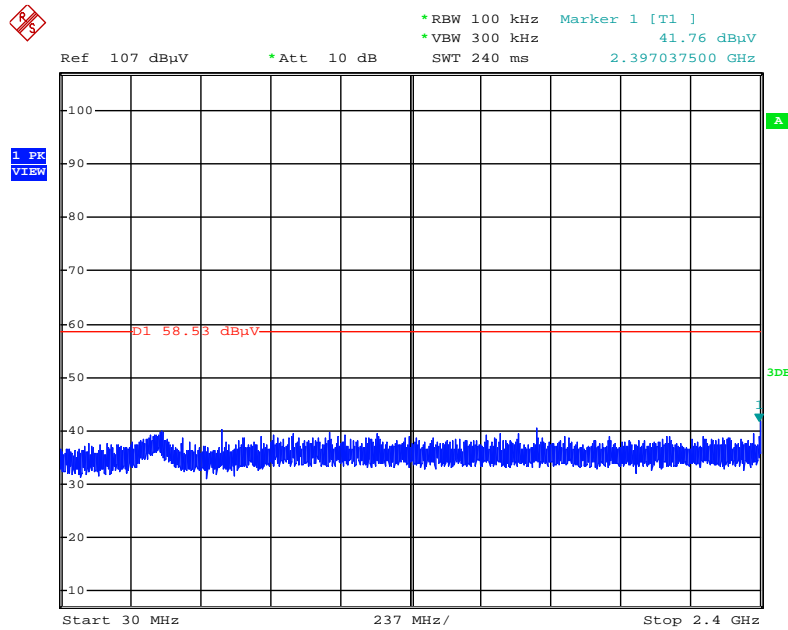

Date: 14.APR.2016 02:01:18

Plot on Configuration IEEE 802.11ac MCS0/NSS1 VHT40 / CH 3 / 2483.5MHz~26500MHz (down 30dBc)

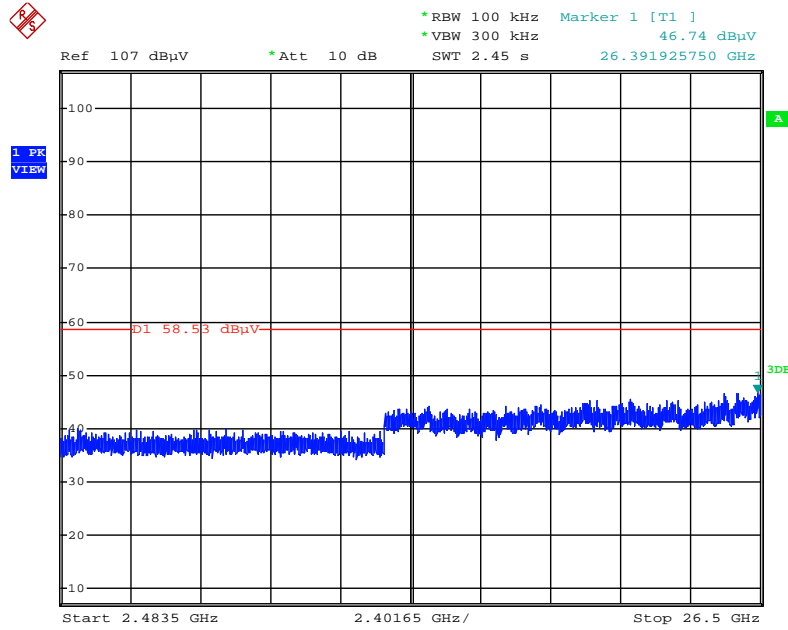

Date: 14.APR.2016 02:01:51

Plot on Configuration IEEE 802.11ac MCS0/NSS1 VHT40 / CH 9 / 30MHz~2400MHz (down 30dBc)

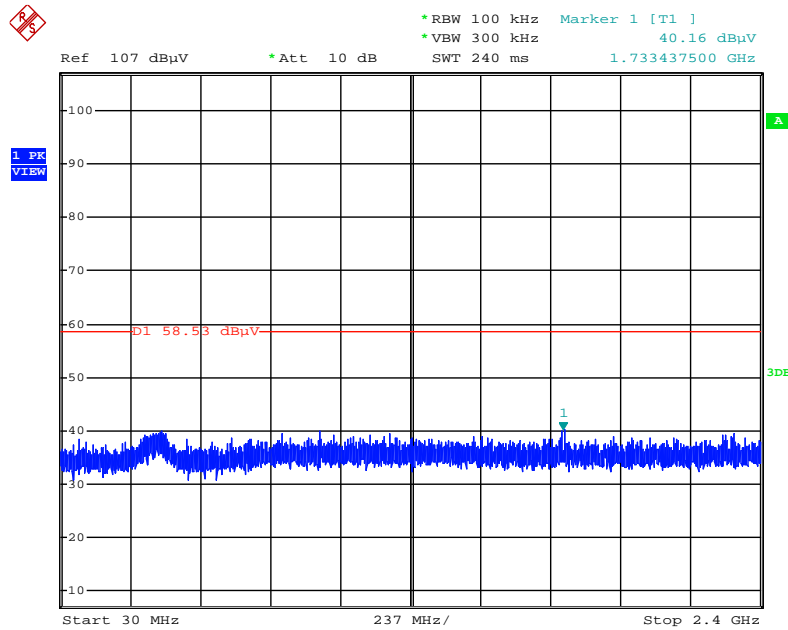

Date: 14.APR.2016 02:03:08

Plot on Configuration IEEE 802.11ac MCS0/NSS1 VHT40 / CH 9 / 2483.5MHz~26500MHz (down 30dBc)

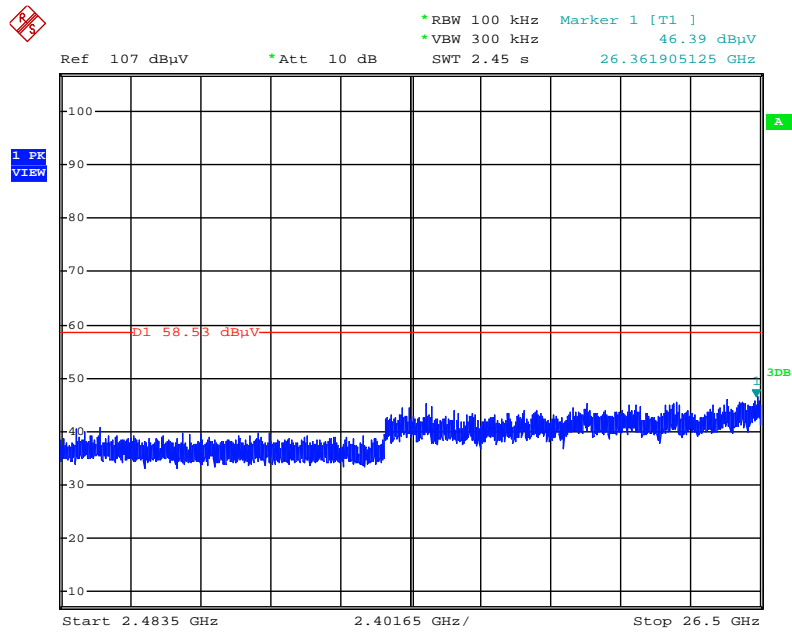

Date: 14.APR.2016 02:02:20

<For beamforming mode>

Plot on Configuration IEEE 802.11ac MCS0/Nss1 VHT20 / Reference Level

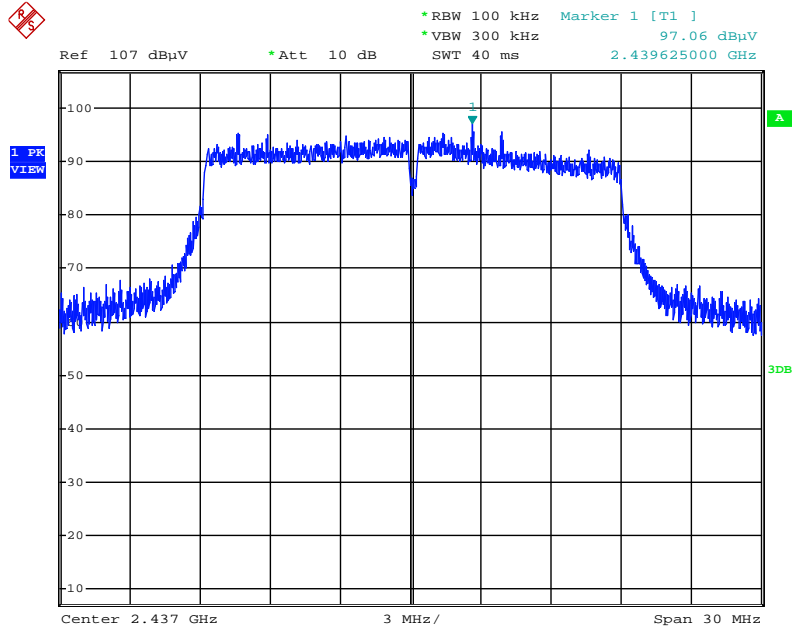

Date: 16.APR.2016 02:19:29

Plot on Configuration IEEE 802.11ac MCS0/Nss1 VHT20 / CH 1 / 30MHz~2400MHz (down 30dBc)

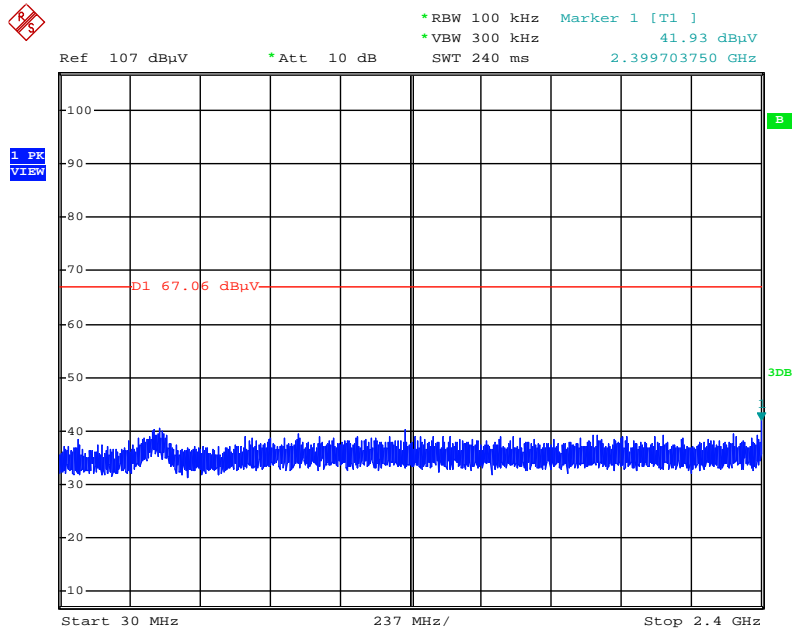

Date: 16.APR.2016 02:21:57

Plot on Configuration IEEE 802.11ac MCS0/Nss1 VHT20 / CH 1 / 2483.5MHz~26500MHz (down 30dBc)

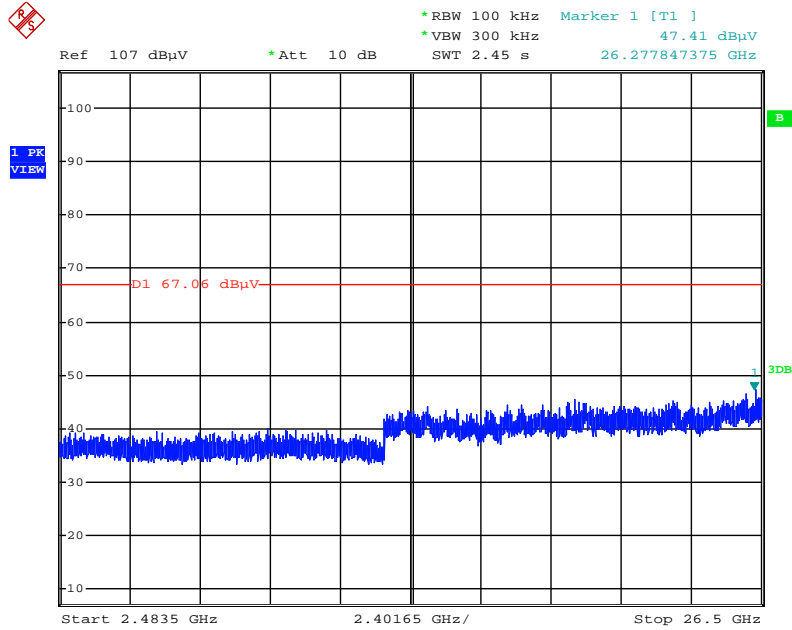

Date: 16.APR.2016 02:23:01

Plot on Configuration IEEE 802.11ac MCS0/Nss1 VHT20 / CH 11 / 30MHz~2400MHz (down 30dBc)

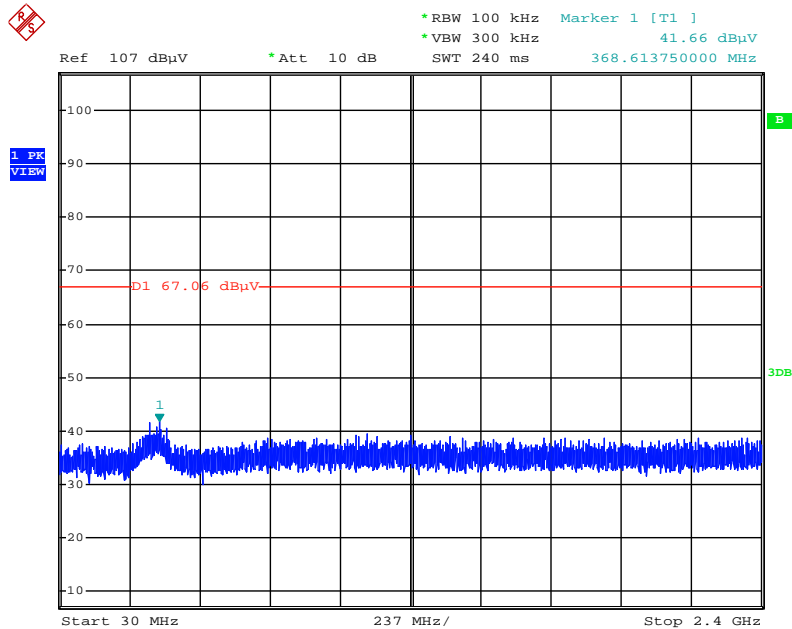

Date: 16.APR.2016 02:25:47

Plot on Configuration IEEE 802.11ac MCS0/Nss1 VHT20 / CH 11 / 2483.5MHz~26500MHz (down 30dBc)

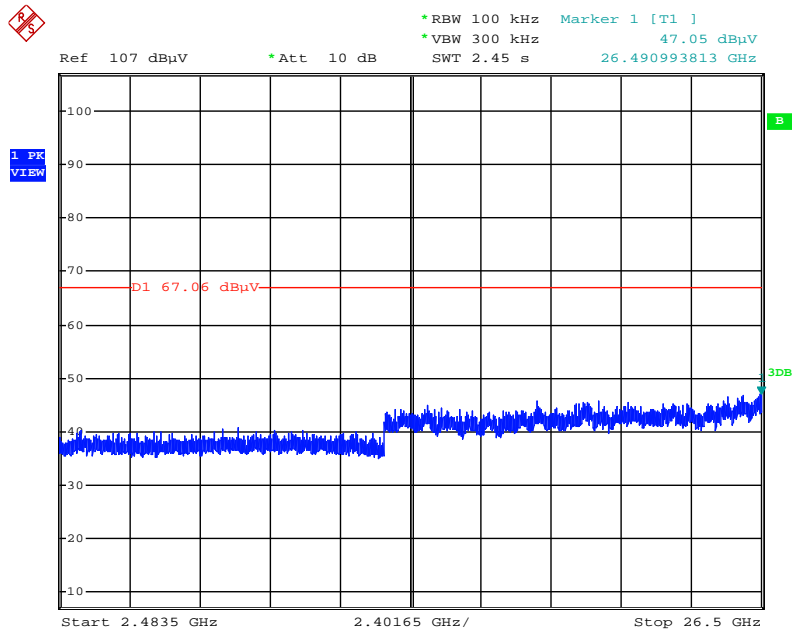

Date: 16.APR.2016 02:24:27

Plot on Configuration IEEE 802.11ac MCS0/NSS1 VHT40 / Reference Level

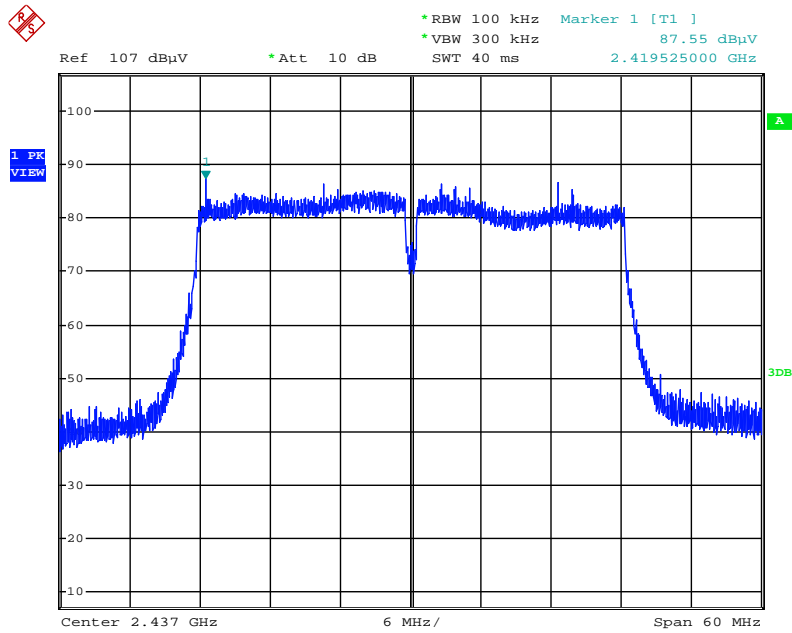

Date: 16.APR.2016 02:28:02

Plot on Configuration IEEE 802.11ac MCS0/NSS1 VHT40 / CH 3 / 30MHz~2400MHz (down 30dBc)

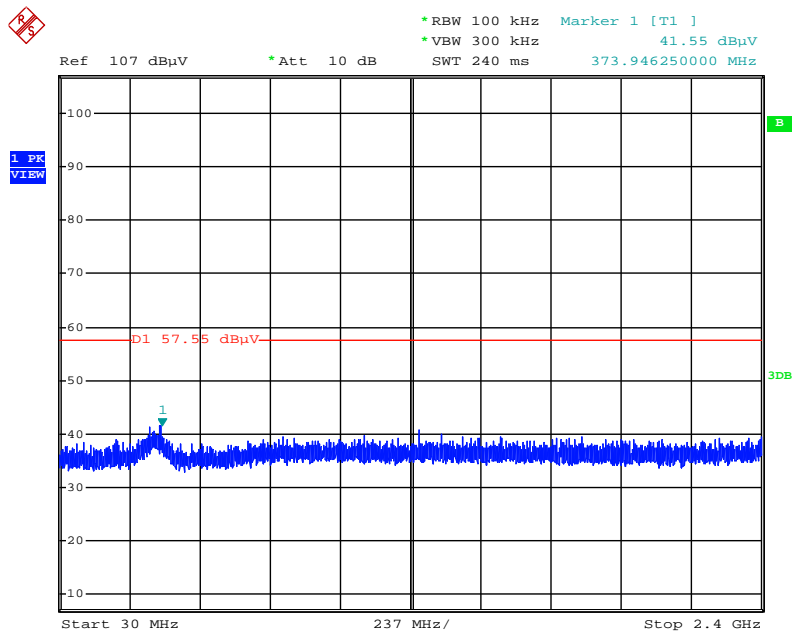

Date: 16.APR.2016 02:29:45

Plot on Configuration IEEE 802.11ac MCS0/NSS1 VHT40 / CH 3 / 2483.5MHz~26500MHz (down 30dBc)

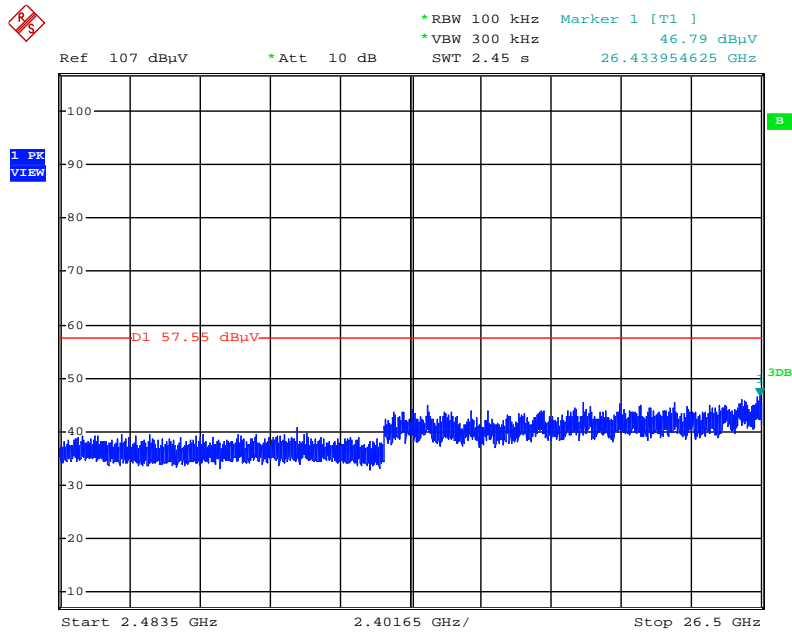

Date: 16.APR.2016 02:30:13

Plot on Configuration IEEE 802.11ac MCS0/NSS1 VHT40 / CH 9 / 30MHz~2400MHz (down 30dBc)

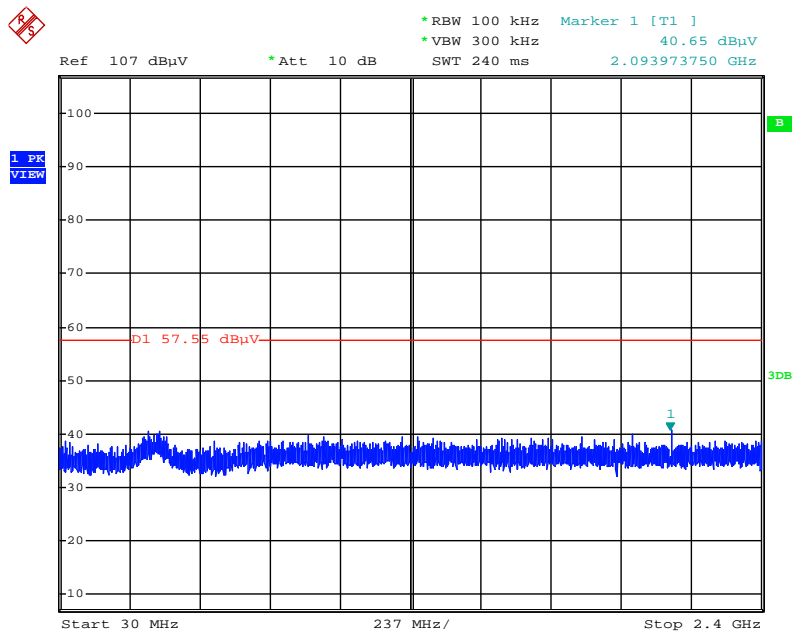

Date: 16.APR.2016 02:31:26

Plot on Configuration IEEE 802.11ac MCS0/NSS1 VHT40 / CH 9 / 2483.5MHz~26500MHz (down 30dBc)

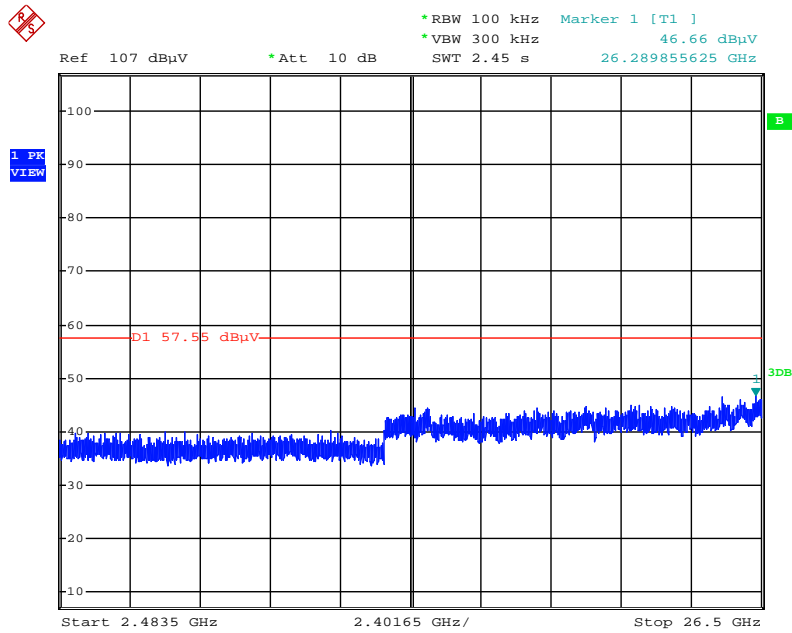

Date: 16.APR.2016 02:31:01

4.7. Antenna Requirements

4.7.1. Limit

Except for special regulations, the Low-power Radio-frequency Devices must not be equipped with any jacket for installing an antenna with extension cable. An intentional radiator shall be designed to ensure that no antenna other than that furnished by the responsible party shall be used with the device. The use of a permanently attached antenna or of an antenna that uses a unique coupling to the intentional radiator shall be considered sufficient to comply with the provisions of this Section. The manufacturer may design the unit so that the user can replace a broken antenna, but the use of a standard antenna jack or electrical connector is prohibited. Further, this requirement does not apply to intentional radiators that must be professionally installed.

4.7.2. Antenna Connector Construction

Please refer to section 3.3 in this test report; antenna connector complied with the requirements.

5. LIST OF MEASURING EQUIPMENTS

Instrument	Manufacturer	Model No.	Serial No.	Characteristics	Calibration Date	Remark
EMI Receiver	Agilent	N9038A	My52260123	9kHz ~ 8.45GHz	Jan. 27, 2016	Conduction (CO01-CB)
LISN	F.C.C.	FCC-LISN-50-16-2	04083	150kHz ~ 100MHz	Dec. 08, 2015	Conduction (CO01-CB)
LISN	Schwarzbeck	NSLK 8127	8127647	9kHz ~ 30MHz	Dec. 23, 2015	Conduction (CO01-CB)
COND Cable	Woken	Cable	01	150kHz ~ 30MHz	May 25, 2015	Conduction (CO01-CB)
Software	Audix	E3	6.120210n	-	N.C.R.	Conduction (CO01-CB)
BILOG ANTENNA	TESEQ	CBL6112D	37880	20MHz ~ 2GHz	Sep. 03, 2015	Radiation (03CH01-CB)
Loop Antenna	Teseq	HLA 6120	24155	9kHz - 30 MHz	Mar. 16, 2016*	Radiation (03CH01-CB)
Horn Antenna	EMCO	3115	00075790	750MHz ~ 18GHz	Oct. 22, 2015	Radiation (03CH01-CB)
Horn Antenna	Schwarzbeck	BBHA 9170	BBHA9170252	15GHz ~ 40GHz	Jul. 21, 2015	Radiation (03CH01-CB)
Pre-Amplifier	Agilent	8447D	2944A10991	0.1MHz ~ 1.3GHz	Mar. 15, 2016	Radiation (03CH01-CB)
Pre-Amplifier	Agilent	8449B	3008A02310	1GHz ~ 26.5GHz	Jan. 18, 2016	Radiation (03CH01-CB)
Pre-Amplifier	WM	TF-130N-R1	923365	26GHz ~ 40GHz	Nov. 13, 2015	Radiation (03CH01-CB)
Spectrum Analyzer	R&S	FSP40	100056	9kHz ~ 40GHz	Oct. 27, 2015	Radiation (03CH01-CB)
EMI Test	R&S	ESCS	100355	9kHz ~ 2.75GHz	May 16, 2016	Radiation (03CH01-CB)
RF Cable-low	Woken	Low Cable-1	N/A	30 MHz ~ 1 GHz	Nov. 02, 2015	Radiation (03CH01-CB)
RF Cable-high	Woken	High Cable-16	N/A	1 GHz ~ 18 GHz	Nov. 02, 2015	Radiation (03CH01-CB)
RF Cable-high	Woken	High Cable-17	N/A	1 GHz ~ 18 GHz	Nov. 02, 2015	Radiation (03CH01-CB)
RF Cable-high	Woken	High Cable-40G-1	N/A	18GHz ~ 40 GHz	Nov. 02, 2015	Radiation (03CH01-CB)
RF Cable-high	Woken	High Cable-40G-2	N/A	18GHz ~ 40 GHz	Nov. 02, 2015	Radiation (03CH01-CB)
Test Software	Audix	E3	6.2009-10-7	N/A	N/A	Radiation (03CH01-CB)
Spectrum analyzer	R&S	FSV40	100979	9kHz~40GHz	Dec. 09, 2015	Conducted (TH01-CB)
Temp. and Humidity Chamber	Ten Billion	TTH-D3SP	TBN-931011	-30~100 degree	Jun. 02, 2015	Conducted (TH01-CB)
Temp. and Humidity Chamber	Ten Billion	TTH-D3SP	TBN-931011	-30~100 degree	Jun. 03, 2016	Conducted (TH01-CB)
RF Cable-high	Woken	RG402	High Cable-6	1 GHz – 26.5 GHz	Nov. 02, 2015	Conducted (TH01-CB)
RF Cable-high	Woken	RG402	High Cable-7	1 GHz – 26.5 GHz	Nov. 02, 2015	Conducted (TH01-CB)
RF Cable-high	Woken	RG402	High Cable-8	1 GHz – 26.5 GHz	Nov. 02, 2015	Conducted (TH01-CB)



Instrument	Manufacturer	Model No.	Serial No.	Characteristics	Calibration Date	Remark
RF Cable-high	Woken	RG402	High Cable-9	1 GHz – 26.5 GHz	Nov. 02, 2015	Conducted (TH01-CB)
RF Cable-high	Woken	RG402	High Cable-10	1 GHz – 26.5 GHz	Nov. 02, 2015	Conducted (TH01-CB)
Power Sensor	Agilent	U2021XA	MY53410001	50MHz~18GHz	Nov. 02, 2015	Conducted (TH01-CB)

Note: Calibration Interval of instruments listed above is one year.

“*” Calibration Interval of instruments listed above is two years.

N.C.R. means Non-Calibration required.

6. MEASUREMENT UNCERTAINTY

Test Items	Uncertainty	Remark
Conducted Emission (150kHz ~ 30MHz)	3.2 dB	Confidence levels of 95%
Radiated Emission (30MHz ~ 1,000MHz)	3.6 dB	Confidence levels of 95%
Radiated Emission (1GHz ~ 18GHz)	3.7 dB	Confidence levels of 95%
Radiated Emission (18GHz ~ 40GHz)	3.5 dB	Confidence levels of 95%
Conducted Emission	1.7 dB	Confidence levels of 95%