

FCC Test Report

Product Name : Lyra
Trade Name : ASUS
Model No. : MAP-AC2200
FCC ID. : MSQ-RTACBX00

Applicant : ASUSTeK COMPUTER INC.

Address : 4F, No. 150, Li-Te Rd., Peitou, Taipei, Taiwan

Date of Receipt : Mar. 06, 2017
Issued Date : May 10, 2017
Report No. : 1730116R-RFUSP05V00
Report Version : V1.0



The test results relate only to the samples tested.

The test report shall not be reproduced except in full without the written approval of DEKRA Testing and Certification Co., Ltd.

Test Report Certification

Issued Date: May 10, 2017

Report No. : 1730116R-RFUSP05V00



Product Name : Lyra
Applicant : ASUSTeK COMPUTER INC.
Address : 4F, No. 150, Li-Te Rd., Peitou, Taipei, Taiwan
Manufacturer : ASUSTeK COMPUTER INC.
Model No. : MAP-AC2200
FCC ID. : MSQ-RTACBX00
EUT Voltage : AC 100-240V, 50-60Hz
Testing Voltage : AC 120V/ 60Hz
Trade Name : ASUS
Applicable Standard : FCC CFR Title 47 Part 15 Subpart E Section 15.407: 2015
ANSI C63.10: 2013
Test Result : Complied
Laboratory Name : Hsin Chu Laboratory
Address : No. 75-2, 3rd Lin, WangYe Keng, Yonghxing Tsuen,
Qionglin Shiang, Hsinchu County 307, Taiwan (R.O.C.)
TEL: +886-3-592-8858 / FAX: +886-3-592-8859

Documented By :



(Demi Chang / Senior Engineering Adm. Specialist)

Tested By :



(Clemens Fang / Engineer)

Approved By :

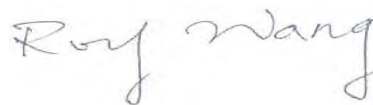

(Roy Wang / Director)

Revision History

Report No.	Version	Description	Issued Date
1730116R-RFUSP05V00	V1.0	Initial issue of report	May 10, 2017

Laboratory Information

We, **DEKRA Testing and Certification Co., Ltd.**, are an independent RF consultancy that was established the whole facility in our laboratories. The test facility has been accredited/accepted (audited or listed) by the following related bodies in compliance with ISO 17025 specified testing scopes:

Taiwan R.O.C.	:	TAF, Accreditation Number: 3024
USA	:	FCC, Registration Number: 834100
Canada	:	IC, Submission No: 181665 IC Registration Number: 22397-1 / 22397-2 / 22397-3

The related certificate for our laboratories about the test site and management system can be downloaded from DEKRA Testing and Certification Co., Ltd. Web Site:

<http://www.dekra.com.tw/english/about/certificates.aspx?bval=5>

The address and introduction of DEKRA Testing and Certification Co., Ltd. laboratories can be founded in our Web site : http://www.dekra.com.tw/index_en.aspx

If you have any comments, Please don't hesitate to contact us. Our contact information is as below:

- 1 No. 75-2, 3rd Lin, WangYe Keng, Yonghxing Tsuen, Qionglin Shiang, Hsinchu County 307, Taiwan (R.O.C.)
TEL:+886-3-592-8858 / FAX:+886-3-592-8859 E-Mail : info.tw@dekra.com
- 2 No.372, Sec. 4, Zhongxing Rd., Zhudong Township, Hsinchu County 31061, Taiwan
TEL: +886-3-582-8001 / FAX: +886-3-582-8958 E-Mail : info.tw@dekra.com
- 3 No.372-2, Sec. 4, Zhongxing Rd., Zhudong Township, Hsinchu County 31061, Taiwan
TEL: +886-3-582-8001 / FAX: +886-3-582-8958 E-Mail : info.tw@dekra.com

TABLE OF CONTENTS

Description	Page
1. General Information	7
1.1. EUT DESCRIPTION.....	7
1.2. TEST MODE.....	12
1.3. SYSTEM DETAILS.....	13
1.4. CONFIGURATION OF TESTED SYSTEM.....	13
1.5. EUT EXERCISE SOFTWARE.....	13
1.6. TEST FACILITY.....	14
2. Conducted Emission	15
2.1. TEST EQUIPMENT.....	15
2.2. TEST SETUP.....	15
2.3. LIMITS.....	16
2.4. TEST PROCEDURE.....	16
2.5. TEST SPECIFICATION.....	16
2.6. UNCERTAINTY.....	16
2.7. TEST RESULT.....	17
3. 99% & DTS Bandwidth	25
3.1. TEST EQUIPMENT.....	25
3.2. TEST SETUP.....	25
3.3. LIMITS.....	26
3.4. TEST PROCEDURE.....	26
3.5. UNCERTAINTY.....	26
3.6. TEST RESULT.....	27
4. Peak Transmit power	81
4.1. TEST EQUIPMENT.....	81
4.2. TEST SETUP.....	81
4.3. LIMITS.....	82
4.4. TEST PROCEDURE.....	82
4.5. UNCERTAINTY.....	82
4.6. TEST RESULT.....	83
5. Peak Power Spectrum Density	180
5.1. TEST EQUIPMENT.....	181
5.2. TEST SETUP.....	181
5.3. LIMITS.....	182
5.4. TEST PROCEDURE.....	182

5.5.	UNCERTAINTY	182
5.6.	TEST RESULT.....	183
6.	Radiated Emission.....	269
6.1.	TEST EQUIPMENT.....	269
6.2.	TEST SETUP	269
6.3.	LIMITS	270
6.4.	TEST PROCEDURE	271
6.5.	UNCERTAINTY	271
6.6.	TEST RESULT.....	272
7.	Band Edge	376
7.1.	TEST EQUIPMENT.....	376
7.2.	TEST SETUP	376
7.3.	LIMITS	377
7.4.	TEST PROCEDURE	379
7.5.	UNCERTAINTY	379
7.6.	TEST RESULT.....	380
8.	Frequency Stability.....	470
8.1.	TEST EQUIPMENT.....	470
8.2.	TEST SETUP	470
8.3.	LIMITS	470
8.4.	TEST PROCEDURE	470
8.5.	UNCERTAINTY	470
8.6.	TEST RESULT.....	471
ATTACHMENT 1		485
TEST SETUP PHOTOGRAPH		485
ATTACHMENT 2.....		490
EUT EXTERNAL PHOTOGRAPH.....		490
ATTACHMENT 3.....		496
EUT INTERNAL PHOTOGRAPH.....		496

1. General Information

1.1. EUT Description

Product Name	Lyra	
Trade Name	ASUS	
Model No.	MAP-AC2200	
Frequency Range/ Channel Number	IEEE 802.11a/	5180~5240MHz / 4 Channels
	IEEE 802.11n (20MHz) /	5745~5825MHz / 5 Channels
	IEEE 802.11ac (20MHz)	
	IEEE 802.11n (40MHz) /	5190~5230MHz / 2 Channels
	IEEE 802.11ac (40MHz)	5755~5795MHz / 2 Channels
	IEEE 802.11ac (80MHz)	5210~5210MHz / 1 Channel
		5775~5775MHz / 1 Channel
Type of Modulation	IEEE 802.11a/n/ac	Orthogonal Frequency Division Multiplexing (OFDM)
Data Speed	IEEE 802.11a	6, 9,12,18, 24, 36, 48, 54Mbps
	IEEE 802.11n	Support a subset of the combination of GI, MCS 0~MCS 15 and bandwidth defined in 802.11n
	IEEE 802.11ac	Support a subset of the combination of GI, MCS 0~MCS 9 and bandwidth defined in 802.11ac

Antenna Information	
Antenna Type	PCB Antenna
Antenna Gain	5G (QCA 9886_Low): ANT0: 4.31dBi ANT1: 3.2dBi 5G (IPQ4019_High): ANT0: 3.43dBi ANT1: 3.99dBi
Beamforming Gain	3.01 dBi

Accessories Information	
LAN Cable	Non-Shielded, 2m
Power Adapter	ASUS, AD2055320 I/P: 100-240V~50/60Hz, 0.6A O/P: 12V $\overline{=}$ 2.0A Cable Out: Non-Shielded, 2.2m
Power Adapter	ASUS, ADP-24EW B I/P: 100-240V ~50-60Hz, 0.9A O/P: 12V $\overline{=}$ 2.0A Cable Out: Non-Shielded, 2.2m

ANT-TX / RX & Bandwidth

ANT-TX / RX	TX			RX		
	20MHz	40MHz	80MHz	20MHz	40MHz	80MHz
IEEE802.11a	✓			✓		
IEEE802.11n	✓	✓		✓	✓	
IEEE802.11ac	✓	✓	✓	✓	✓	✓

IEEE 802.11n

MCS Index	Modulation	R	N _{BPSCS}	N _{CBPS}		N _{DBPS}		Data Rate(Mb/s)			
				20MHz	40MHz	20MHz	40MHz	800ns GI		400ns GI	
								20MHz	40MHz	20MHz	40MHz
0	BPSK	1/2	1	52	108	26	54	6.5	13.5	7.2	15.0
1	QPSK	1/2	2	104	216	52	108	13.0	27.0	14.4	30.0
2	QPSK	3/4	2	104	216	78	162	19.5	40.5	21.7	45.0
3	16-QAM	1/2	4	208	432	104	216	26.0	54.0	28.9	60.0
4	16-QAM	3/4	4	208	432	156	324	39.0	81.0	43.3	90.0
5	64-QAM	2/3	6	312	648	208	432	52.0	108.0	57.8	120.0
6	64-QAM	3/4	6	312	648	234	486	58.5	121.5	65.0	135.0
7	64-QAM	5/6	6	312	648	260	540	65.0	135.0	72.2	150.0

Note 1: Support of 400ns GI is optional on transmit and receive.

Table 1 – MCS parameters for TX Antenna number = 1

MCS Index	Modulation	R	N _{BPSCS}	N _{CBPS}		N _{DBPS}		Data Rate(Mb/s)			
				20MHz	40MHz	20MHz	40MHz	800ns GI		400ns GI	
								20MHz	40MHz	20MHz	40MHz
8	BPSK	1/2	1	104	216	52	108	13.0	27.0	14.4	30.0
9	QPSK	1/2	2	208	432	104	216	26.0	54.0	28.9	60.0
10	QPSK	3/4	2	208	432	156	324	39.0	81.0	43.3	90.0
11	16-QAM	1/2	4	416	864	208	432	52.0	108.0	57.8	120.0
12	16-QAM	3/4	4	416	864	312	648	78.0	162.0	86.7	180.0
13	64-QAM	2/3	6	624	1296	416	864	104.0	216.0	115.6	240.0
14	64-QAM	3/4	6	624	1296	468	972	117.0	243.0	130.0	270.0
15	64-QAM	5/6	6	624	1296	520	1080	130.0	270.0	144.4	300.0

Note 1: Support of 400ns GI is optional on transmit and receive.

Table 2 – MCS parameters for TX Antenna number = 2

Symbol	Explanation
R	Code rate
N _{BPSC}	Number of coded bits per single carrier
N _{CBPS}	Number of coded bits per symbol
N _{DBPS}	Number of data bits per symbol
GI	guard interval

IEEE 802.11ac Data Rate

Spatial Streams (Note1)	MCS Index	Modulation type	Coding rate	Data Rate(Mb/s)					
				20 MHz		40 MHz		80 MHz	
				Guard Interval		Guard Interval		Guard Interval	
				800ns	400ns	800ns	400ns	800ns	400ns
1	0	BPSK	1/2	6.5	7.2	13.5	15	29.3	32.5
	1	QPSK	1/2	13	14.4	27	30	58.5	65
	2	QPSK	3/4	19.5	21.7	40.5	45	87.8	97.5
	3	16-QAM	1/2	26	28.9	54	60	117	130
	4	16-QAM	3/4	39	43.3	81	90	175.5	195
	5	64-QAM	2/3	52	57.8	108	120	234	260
	6	64-QAM	3/4	58.5	65	121.5	135	263.3	292.5
	7	64-QAM	5/6	65	72.2	135	150	292.5	325
	8	256-QAM	3/4	78	86.7	162	180	351	390
	9	256-QAM	5/6	N/A	N/A	180	200	390	433.3
2	0	BPSK	1/2	13	14.4	27	30	58.6	65
	1	QPSK	1/2	26	28.8	54	60	117	130
	2	QPSK	3/4	39	43.4	81	90	175.6	195
	3	16-QAM	1/2	52	57.8	108	120	234	260
	4	16-QAM	3/4	78	86.6	162	180	351	390
	5	64-QAM	2/3	104	115.6	216	240	468	520
	6	64-QAM	3/4	117	130	243	270	526.6	585
	7	64-QAM	5/6	130	144.4	270	300	585	650
	8	256-QAM	3/4	156	173.4	324	360	702	780
	9	256-QAM	5/6	N/A	N/A	360	400	780	866.6

IEEE 802.11a & IEEE 802.11n (20MHz) & IEEE 802.11ac (20MHz)

Working Frequency of Each Channel							
Channel	Frequency	Channel	Frequency	Channel	Frequency	Channel	Frequency
36	5180 MHz	40	5200 MHz	44	5220 MHz	48	5240 MHz
149	5745 MHz	153	5765 MHz	157	5785 MHz	161	5805 MHz
165	5825 MHz						

IEEE 802.11n (40MHz)&IEEE 802.11ac (40MHz)

Working Frequency of Each Channel							
Channel	Frequency	Channel	Frequency	Channel	Frequency	Channel	Frequency
38	5190 MHz	46	5230 MHz	151	5755 MHz	159	5795 MHz

IEEE 802.11ac (80MHz)

Working Frequency of Each Channel	
Channel	Frequency
42	5210 MHz
155	5775 MHz

Note:

1. This device is a Lyra including 2.4GHz b/g/n (2x2), BT2.0, BT4.0 and 5GHz a/n/ac (2x2) transmitting and receiving function.
2. Regards to the frequency band operation; the lowest , middle and highest frequency of channel were selected to perform the test, and then shown on this report.
3. This device is a composite device in accordance with Part 15 regulations. The receiving function was tested and its number is 1730116R-RFUSP12V00.

1.2. Test Mode

DEKRA has verified the construction and function in typical operation. The preliminary tests were performed in different data rate, and to find the worst condition, which was shown in this test report. The following table is the final test mode.

TX	Mode 1: Tx-AD2055320 Mode Mode 2: Tx-AD2055320 BF Mode Mode 3: Tx-ADP-24EW B Mode
----	---

Test Items	Modulation	Channel	Antenna	Result
Conducted Emission	11ac (80MHz)	42/155	0+1	Complies
99% & 20dB & DTS Bandwidth	a	36/44/48/149/157/165	0/1	Complies
	11n/ac (20MHz)	36/44/48/149/157/165	0/1	Complies
	11n/ac (40MHz)	38/46/151/159	0/1	Complies
	11ac (80MHz)	42/155	0/1	Complies
Peak Transmit Output	a	36/44/48/149/157/165	0+1	Complies
	11n/ac (20MHz)	36/44/48/149/157/165	0+1	Complies
	11n/ac (40MHz)	38/46/151/159	0+1	Complies
	11ac (80MHz)	42/155	0+1	Complies
Peak Power Spectrum Density	a	36/44/48/149/157/165	0+1	Complies
	11n/ac (20MHz)	36/44/48/149/157/165	0+1	Complies
	11n/ac (40MHz)	38/46/151/159	0+1	Complies
	11ac (80MHz)	42/155	0+1	Complies
Radiated Emission	a	36/44/48/149/157/165	0+1	Complies
	11n/ac (20MHz)	36/44/48/149/157/165	0+1	Complies
	11n/ac (40MHz)	38/46/151/159	0+1	Complies
	11ac (80MHz)	42/155	0+1	Complies
Band Edge	a	36/44/48/149/157/165	0+1	Complies
	11n/ac (20MHz)	36/44/48/149/157/165	0+1	Complies
	11n/ac (40MHz)	38/46/151/159	0+1	Complies
	11ac (80MHz)	42/155	0+1	Complies
Frequency Stability	a	36/44/48/149/157/165	0/1	Complies
	11n/ac (20MHz)	36/44/48/149/157/165	0/1	Complies
	11n/ac (40MHz)	38/46/151/159	0/1	Complies
	11ac (80MHz)	42/155	0/1	Complies

1.3. System Details

The types for all equipments, plus descriptions of all cables used in the tested system (including inserted cards) are:

Product	Manufacturer	Model No.	Serial No.	FCC ID	Power Cord
1 Notebook PC	ASUS	X522EP	E5N0CV04 3264197	DoC	Non-Shielded, 1.8m, one ferrite core bonded

1.4. Configuration of tested System

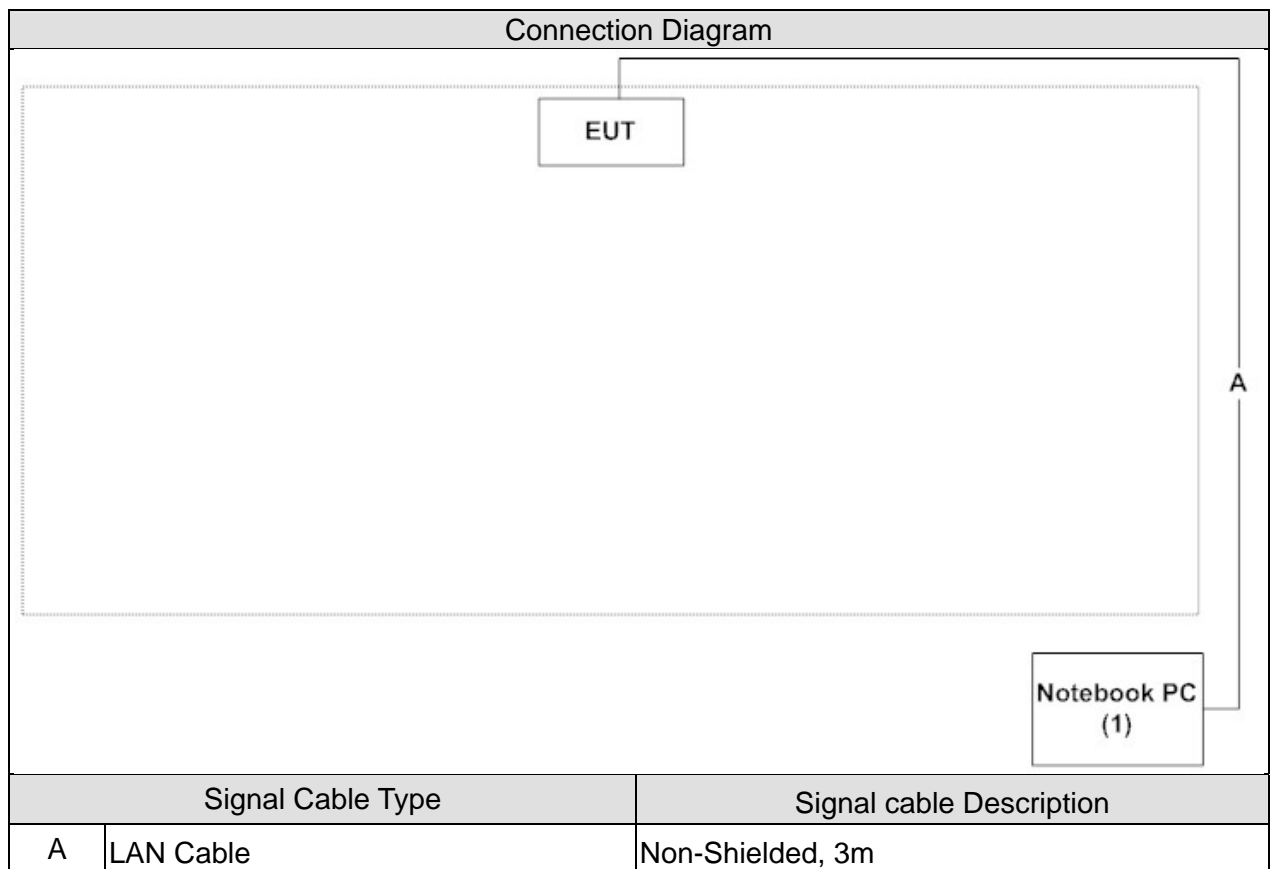

1.5. EUT Exercise Software

1	Setup the EUT as shown in Section 1.4.
2	Execute the test program "QCA Radio Control Toolkit".
3	Configure the test mode, the test channel, and the data rate.
4	Press "Start TX" to start the continuous transmitting.
5	Verify that the EUT works properly.

1.6. Test Facility

Ambient conditions in the laboratory:

Items	Test Item	Required (IEC 68-1)	Actual	Test Site
Temperature (°C)	FCC PART 15 E 15.407 Conducted Emission	15 - 35	20°C	3
Humidity (%RH)		25 - 75	50%RH	
Barometric pressure (mbar)		860 - 1060	950-1000	
Temperature (°C)	FCC PART 15 E 15.407 99% & DTS Bandwidth	15 - 35	25°C	3
Humidity (%RH)		25 - 75	45%RH	
Barometric pressure (mbar)		860 - 1060	950-1000	
Temperature (°C)	FCC PART 15 E 15.407 Peak Transmit Power	15 - 35	25°C	3
Humidity (%RH)		25 - 75	65%RH	
Barometric pressure (mbar)		860 - 1060	950-1000	
Temperature (°C)	FCC PART 15 E 15.407 Peak Power Spectrum Density	15 - 35	25°C	3
Humidity (%RH)		25 - 75	45%RH	
Barometric pressure (mbar)		860 - 1060	950-1000	
Temperature (°C)	FCC PART 15 E 15.407 Radiated Emission	15 - 35	25°C	2
Humidity (%RH)		25 - 75	45%RH	
Barometric pressure (mbar)		860 - 1060	950-1000	
Temperature (°C)	FCC PART 15 E 15.407 Band Edge	15 - 35	25°C	2
Humidity (%RH)		25 - 75	45%RH	
Barometric pressure (mbar)		860 - 1060	950-1000	
Temperature (°C)	FCC PART 15 E 15.407 Frequency Stability	15 - 35	25°C	3
Humidity (%RH)		25 - 75	45%RH	
Barometric pressure (mbar)		860 - 1060	950-1000	

Note: Test site information refers to Laboratory Information.

2. Conducted Emission

2.1. Test Equipment

The following test equipments are used during the test:

Conducted Emission / SR2-H

Instrument	Manufacturer	Model No.	Serial No	Next Cal. Date
Artificial Mains Network	R&S	ENV4200	848411/010	2018/02/05
LISN	R&S	ENV216	100092	2017/08/16
Test Receiver	R&S	ESCS 30	836858/022	2018/04/11

Note: All equipments that need to calibrate are with calibration period of 1 year.

2.2. Test Setup

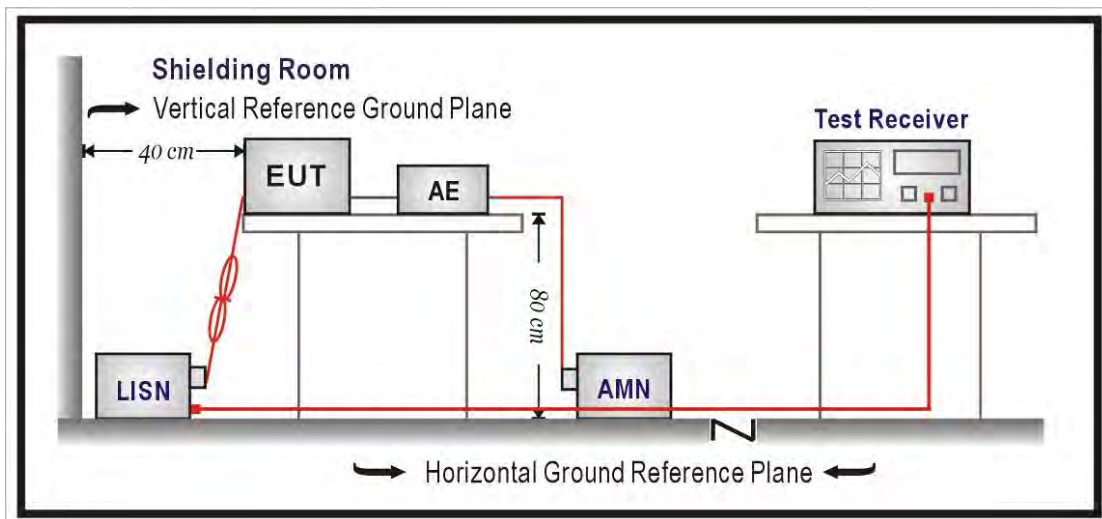

2.3. Limits

FCC Part 15 Subpart C Paragraph 15.207 Limits (dBuV)		
Frequency MHz	QP	AV
0.15 - 0.50	66-56	56-46
0.50 - 5.0	56	46
5.0 - 30	60	50

Remark: In the above table, the tighter limit applies at the band edges.

2.4. Test Procedure

The EUT was setup according to ANSI C63.10:2013. The EUT was placed on a platform of nominal size, 1 m by 1.5 m, raised 80 cm above the conducting ground plane. The vertical conducting plane was located 40 cm to the rear of the EUT. All other surfaces of EUT were at least 80 cm from any other grounded conducting surface. The EUT and simulators are connected to the main power through a line impedance stabilization network (LISN). The LISN provides a 50 ohm /50uH coupling impedance for the measuring equipment. The peripheral devices are also connected to the main power through a LISN. (Please refer to the block diagram of the test setup and photographs.)

Each current-carrying conductor of the EUT power cord, except the ground (safety) conductor, was individually connected through a LISN to the input power source.

The excess length of the power cord between the EUT and the LISN receptacle were folded back and forth at the center of the lead to form a bundle not exceeding 40 cm in length.

Conducted emissions were investigated over the frequency range from 0.15MHz to 30MHz using a receiver bandwidth of 9 kHz.

2.5. Test Specification

According to FCC Part 15 Subpart C Paragraph 15.207: 2015

2.6. Uncertainty

The measurement uncertainty is defined as ± 2.26 dB.

2.7. Test Result

Site : SR2-H	Time : 2017/04/11
Limit : CISPR_B_00M_QP	Margin : 10
Probe : SR2_LISN(16A)-6_0712 - Line1	Power : AC120V/60Hz
EUT : Lyra	Note : 802.11ac(80M)_5210MHz Mode 1: Tx-AD2055320 Mode

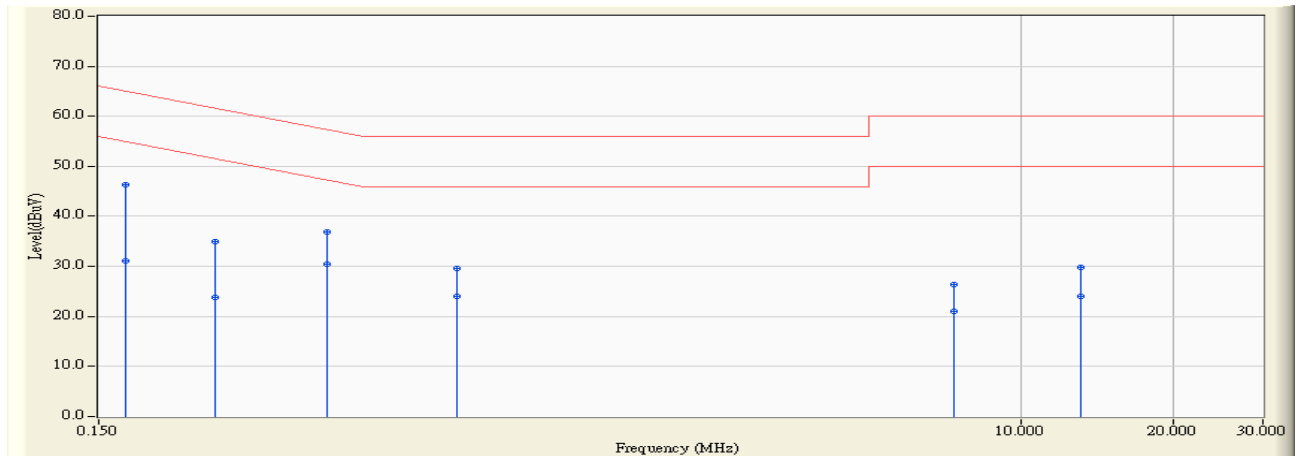

	Frequency (MHz)	Correct Factor (dB)	Reading Level (dBuV)	Measure Level (dBuV)	Margin (dB)	Limit (dBuV)	Detector Type
1	0.170	9.753	36.650	46.403	-18.580	64.983	QUASPEAK
2	0.170	9.753	21.290	31.043	-23.940	54.983	AVERAGE
3	0.255	9.744	25.190	34.934	-26.643	61.577	QUASPEAK
4	0.255	9.744	14.150	23.894	-27.683	51.577	AVERAGE
5	0.423	9.730	27.100	36.830	-20.551	57.380	QUASPEAK
6	* 0.423	9.730	20.800	30.530	-16.851	47.380	AVERAGE
7	0.767	9.777	19.850	29.627	-26.373	56.000	QUASPEAK
8	0.767	9.777	14.290	24.067	-21.933	46.000	AVERAGE
9	7.373	10.021	16.440	26.461	-33.539	60.000	QUASPEAK
10	7.373	10.021	10.930	20.951	-29.049	50.000	AVERAGE
11	13.091	10.186	19.610	29.796	-30.204	60.000	QUASPEAK
12	13.091	10.186	13.860	24.046	-25.954	50.000	AVERAGE

Note:

1. All Reading Levels are Quasi-Peak and average value.
2. " * ", means this data is the worst emission level.
3. Measurement Level = Reading Level + Correct Factor.

Site : SR2-H	Time : 2017/04/11
Limit : CISPR_B_00M_QP	Margin : 10
Probe : SR2_LISN(16A)-6_0712 - Line2	Power : AC120V/60Hz
EUT : Lyra	Note : 802.11ac(80M)_5210MHz Mode 1: Tx-AD2055320 Mode

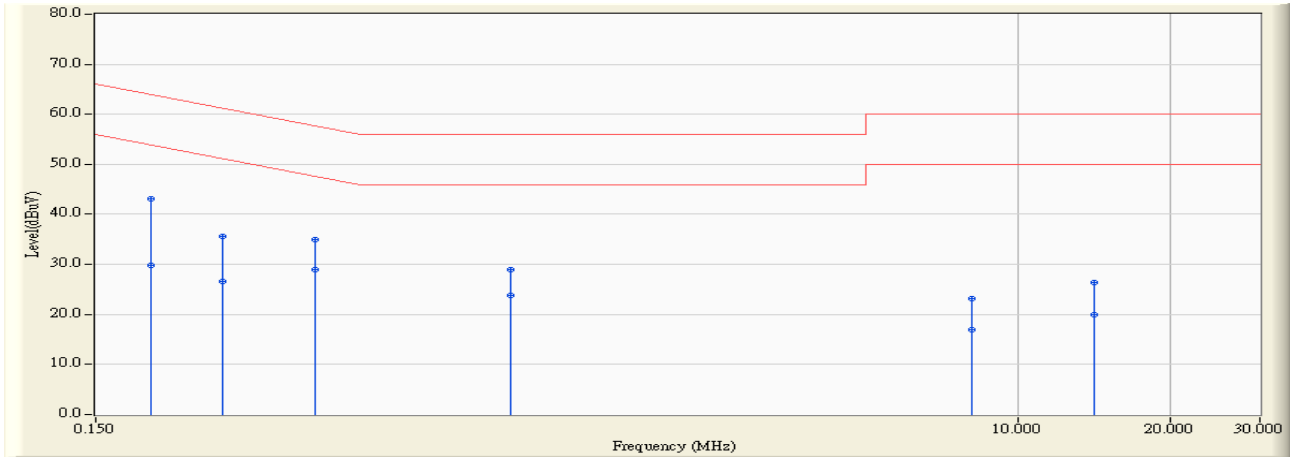

	Frequency (MHz)	Correct Factor (dB)	Reading Level (dBuV)	Measure Level (dBuV)	Margin (dB)	Limit (dBuV)	Detector Type
1	0.193	9.751	33.270	43.021	-20.887	63.908	QUASPEAK
2	0.193	9.751	20.090	29.841	-24.067	53.908	AVERAGE
3	0.267	9.750	25.950	35.700	-25.505	61.205	QUASPEAK
4	0.267	9.750	16.910	26.660	-24.545	51.205	AVERAGE
5	0.408	9.750	25.270	35.020	-22.673	57.693	QUASPEAK
6	*	9.750	19.200	28.950	-18.743	47.693	AVERAGE
7	0.994	9.819	19.140	28.959	-27.041	56.000	QUASPEAK
8	0.994	9.819	14.080	23.899	-22.101	46.000	AVERAGE
9	8.111	10.039	13.030	23.070	-36.930	60.000	QUASPEAK
10	8.111	10.039	6.960	17.000	-33.000	50.000	AVERAGE
11	14.162	10.283	16.090	26.373	-33.627	60.000	QUASPEAK
12	14.162	10.283	9.720	20.003	-29.997	50.000	AVERAGE

Note:

1. All Reading Levels are Quasi-Peak and average value.
2. " * ", means this data is the worst emission level.
3. Measurement Level = Reading Level + Correct Factor.

Site : SR2-H	Time : 2017/04/11
Limit : CISPR_B_00M_QP	Margin : 10
Probe : SR2_LISN(16A)-6_0712 - Line1	Power : AC120V/60Hz
EUT : Lyra	Note : 802.11ac(80M)_5210MHz Mode 3: Tx-ADP-24EW B Mode

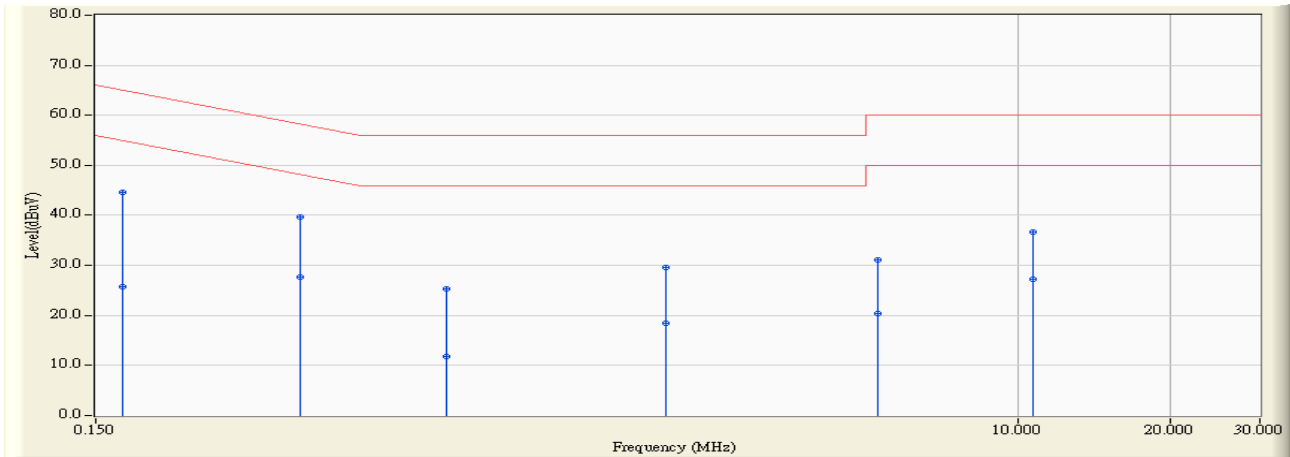

	Frequency (MHz)	Correct Factor (dB)	Reading Level (dBuV)	Measure Level (dBuV)	Margin (dB)	Limit (dBuV)	Detector Type
1	0.170	9.753	34.940	44.693	-20.290	64.983	QUASPEAK
2	0.170	9.753	15.940	25.693	-29.290	54.983	AVERAGE
3	* 0.380	9.732	29.950	39.682	-18.587	58.269	QUASPEAK
4	0.380	9.732	18.020	27.752	-20.517	48.269	AVERAGE
5	0.740	9.772	15.640	25.412	-30.588	56.000	QUASPEAK
6	0.740	9.772	2.010	11.782	-34.218	46.000	AVERAGE
7	2.005	9.860	19.760	29.620	-26.380	56.000	QUASPEAK
8	2.005	9.860	8.610	18.470	-27.530	46.000	AVERAGE
9	5.271	9.933	21.260	31.193	-28.807	60.000	QUASPEAK
10	5.271	9.933	10.440	20.373	-29.627	50.000	AVERAGE
11	10.650	10.142	26.480	36.622	-23.378	60.000	QUASPEAK
12	10.650	10.142	17.150	27.292	-22.708	50.000	AVERAGE

Note:

1. All Reading Levels are Quasi-Peak and average value.
2. " * ", means this data is the worst emission level.
3. Measurement Level = Reading Level + Correct Factor.

Site : SR2-H	Time : 2017/04/11 - 14:21
Limit : CISPR_B_00M_QP	Margin : 10
Probe : SR2_LISN(16A)-6_0712 - Line2	Power : AC120V/60Hz
EUT : Lyra	Note : 802.11ac(80M)_5210MHz Mode 3: Tx-ADP-24EW B Mode

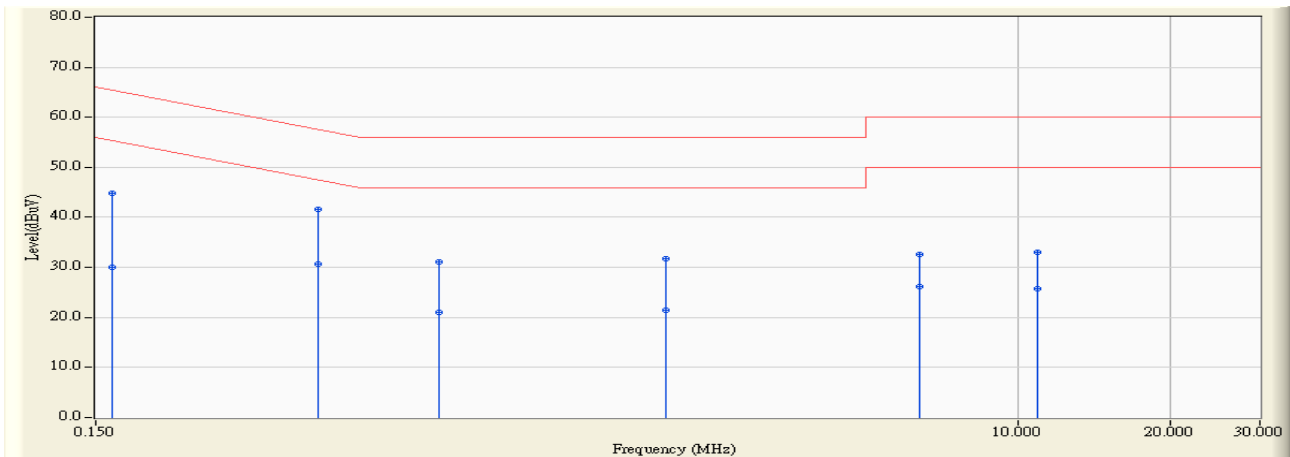

	Frequency (MHz)	Correct Factor (dB)	Reading Level (dBuV)	Measure Level (dBuV)	Margin (dB)	Limit (dBuV)	Detector Type
1	0.162	9.754	35.020	44.774	-20.601	65.375	QUASPEAK
2	0.162	9.754	20.320	30.074	-25.301	55.375	AVERAGE
3	* 0.412	9.749	31.890	41.639	-15.974	57.614	QUASPEAK
4	0.412	9.749	20.950	30.699	-16.914	47.614	AVERAGE
5	0.716	9.777	21.260	31.037	-24.963	56.000	QUASPEAK
6	0.716	9.777	11.150	20.927	-25.073	46.000	AVERAGE
7	2.005	9.850	21.810	31.660	-24.340	56.000	QUASPEAK
8	2.005	9.850	11.650	21.500	-24.500	46.000	AVERAGE
9	6.396	9.940	22.630	32.570	-27.430	60.000	QUASPEAK
10	6.396	9.940	16.130	26.070	-23.930	50.000	AVERAGE
11	10.900	10.179	22.820	32.999	-27.001	60.000	QUASPEAK
12	10.900	10.179	15.600	25.779	-24.221	50.000	AVERAGE

Note:

1. All Reading Levels are Quasi-Peak and average value.
2. " * ", means this data is the worst emission level.
3. Measurement Level = Reading Level + Correct Factor.

Site : SR2-H	Time : 2017/04/11
Limit : CISPR_B_00M_QP	Margin : 10
Probe : SR2_LISN(16A)-6_0712 - Line1	Power : AC120V/60Hz
EUT : Lyra	Note : 802.11ac(80M)_5775MHz Mode 1: Tx-AD2055320 Mode

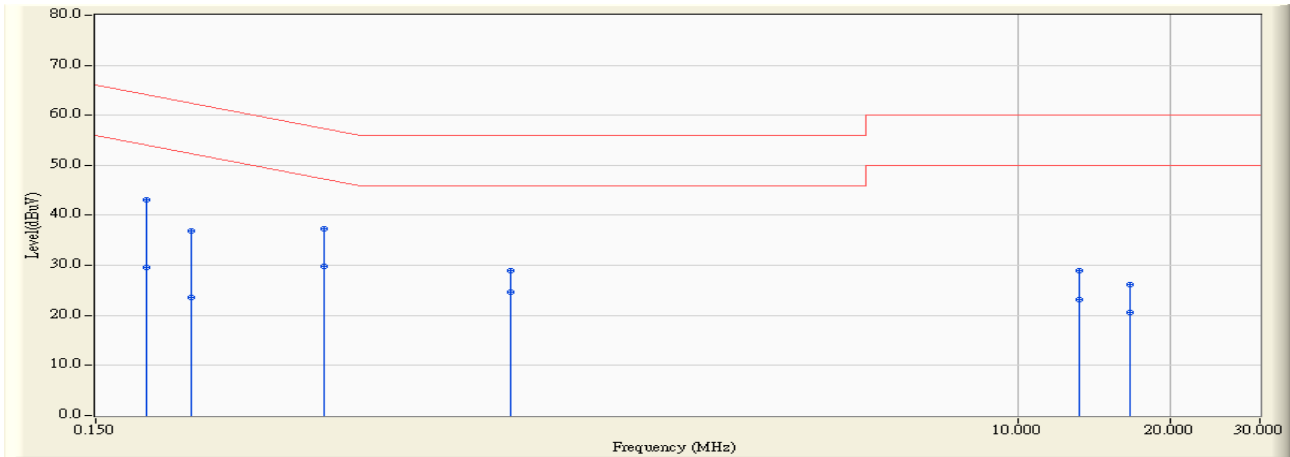

	Frequency (MHz)	Correct Factor (dB)	Reading Level (dBuV)	Measure Level (dBuV)	Margin (dB)	Limit (dBuV)	Detector Type
1	0.189	9.751	33.270	43.021	-21.057	64.078	QUASPEAK
2	0.189	9.751	19.790	29.541	-24.537	54.078	AVERAGE
3	0.232	9.747	27.180	36.927	-25.450	62.377	QUASPEAK
4	0.232	9.747	13.780	23.527	-28.850	52.377	AVERAGE
5	0.423	9.730	27.600	37.330	-20.051	57.380	QUASPEAK
6	* 0.423	9.730	20.020	29.750	-17.631	47.380	AVERAGE
7	0.994	9.819	19.080	28.899	-27.101	56.000	QUASPEAK
8	0.994	9.819	14.780	24.599	-21.401	46.000	AVERAGE
9	13.154	10.187	18.810	28.997	-31.003	60.000	QUASPEAK
10	13.154	10.187	13.070	23.257	-26.743	50.000	AVERAGE
11	16.587	10.258	15.820	26.078	-33.922	60.000	QUASPEAK
12	16.587	10.258	10.360	20.618	-29.382	50.000	AVERAGE

Note:

1. All Reading Levels are Quasi-Peak and average value.
2. " * ", means this data is the worst emission level.
3. Measurement Level = Reading Level + Correct Factor.

Site : SR2-H	Time : 2017/04/11
Limit : CISPR_B_00M_QP	Margin : 10
Probe : SR2_LISN(16A)-6_0712 - Line2	Power : AC120V/60Hz
EUT : Lyra	Note : 802.11ac(80M)_5775MHz Mode 1: Tx-AD2055320 Mode

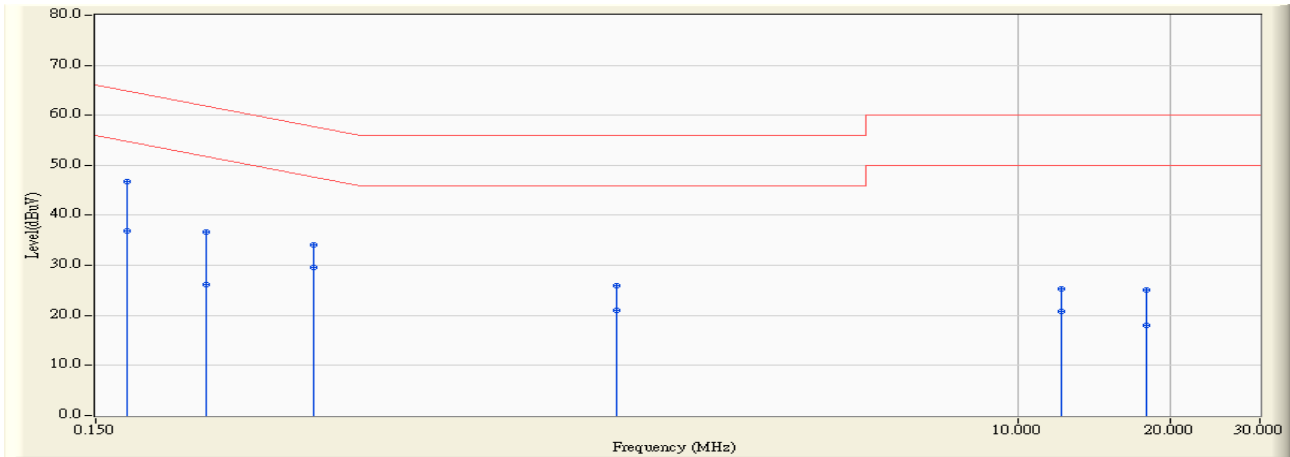

		Frequency (MHz)	Correct Factor (dB)	Reading Level (dBuV)	Measure Level (dBuV)	Margin (dB)	Limit (dBuV)	Detector Type
1	*	0.173	9.753	37.070	46.823	-17.971	64.794	QUASPEAK
2		0.173	9.753	27.050	36.803	-17.991	54.794	AVERAGE
3		0.248	9.750	26.830	36.580	-25.255	61.835	QUASPEAK
4		0.248	9.750	16.380	26.130	-25.705	51.835	AVERAGE
5		0.404	9.750	24.290	34.040	-23.733	57.773	QUASPEAK
6		0.404	9.750	19.790	29.540	-18.233	47.773	AVERAGE
7		1.611	9.838	16.180	26.018	-29.982	56.000	QUASPEAK
8		1.611	9.838	11.080	20.918	-25.082	46.000	AVERAGE
9		12.142	10.219	15.180	25.399	-34.601	60.000	QUASPEAK
10		12.142	10.219	10.500	20.719	-29.281	50.000	AVERAGE
11		17.849	10.418	14.690	25.108	-34.892	60.000	QUASPEAK
12		17.849	10.418	7.520	17.938	-32.062	50.000	AVERAGE

Note:

1. All Reading Levels are Quasi-Peak and average value.
2. " * ", means this data is the worst emission level.
3. Measurement Level = Reading Level + Correct Factor.

Site : SR2-H	Time : 2017/04/11
Limit : CISPR_B_00M_QP	Margin : 10
Probe : SR2_LISN(16A)-6_0712 - Line1	Power : AC120V/60Hz
EUT : Lyra	Note : 802.11ac(80M)_5775MHz Mode 3: Tx-ADP-24EW B Mode

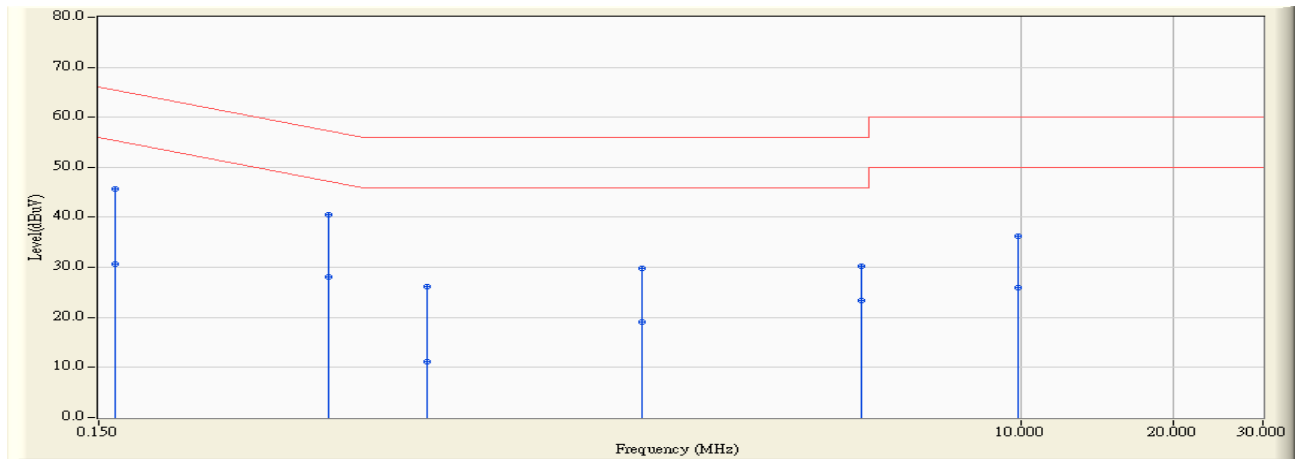

	Frequency (MHz)	Correct Factor (dB)	Reading Level (dBuV)	Measure Level (dBuV)	Margin (dB)	Limit (dBuV)	Detector Type
1	0.162	9.754	35.940	45.694	-19.681	65.375	QUASPEAK
2	0.162	9.754	20.940	30.694	-24.681	55.375	AVERAGE
3	* 0.427	9.730	30.800	40.530	-16.775	57.304	QUASPEAK
4	0.427	9.730	18.290	28.020	-19.285	47.304	AVERAGE
5	0.670	9.760	16.390	26.149	-29.851	56.000	QUASPEAK
6	0.670	9.760	1.500	11.259	-34.741	46.000	AVERAGE
7	1.779	9.851	19.970	29.821	-26.179	56.000	QUASPEAK
8	1.779	9.851	9.220	19.071	-26.929	46.000	AVERAGE
9	4.834	9.921	20.280	30.201	-25.799	56.000	QUASPEAK
10	4.834	9.921	13.420	23.341	-22.659	46.000	AVERAGE
11	9.877	10.125	26.160	36.285	-23.715	60.000	QUASPEAK
12	9.877	10.125	15.740	25.865	-24.135	50.000	AVERAGE

Note:

1. All Reading Levels are Quasi-Peak and average value.
2. " * ", means this data is the worst emission level.
3. Measurement Level = Reading Level + Correct Factor.

Site : SR2-H	Time : 2017/04/11
Limit : CISPR_B_00M_QP	Margin : 10
Probe : SR2_LISN(16A)-6_0712 - Line2	Power : AC120V/60Hz
EUT : Lyra	Note : 802.11ac(80M)_5775MHz Mode 3: Tx-ADP-24EW B Mode

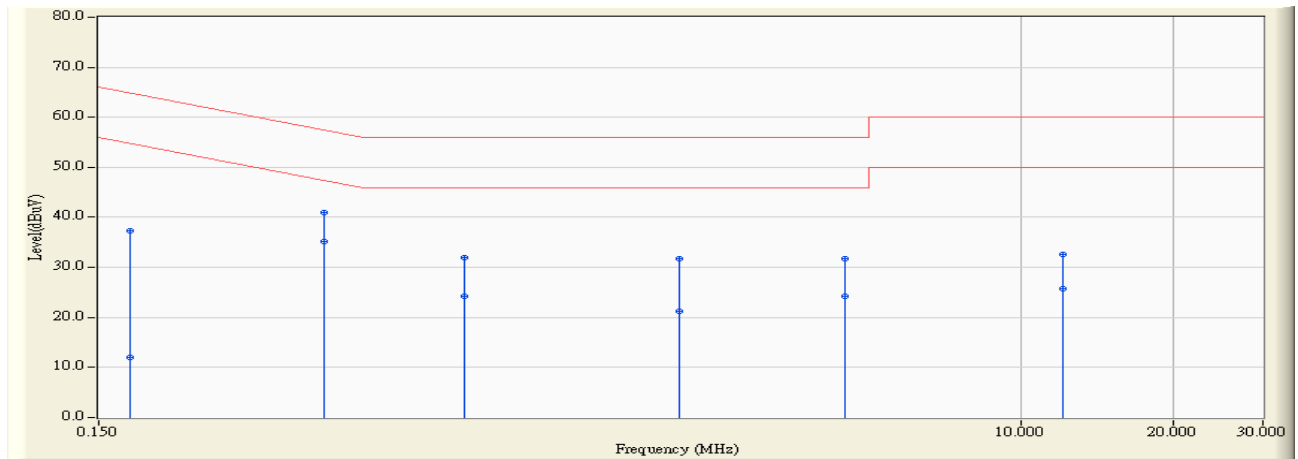

	Frequency (MHz)	Correct Factor (dB)	Reading Level (dBuV)	Measure Level (dBuV)	Margin (dB)	Limit (dBuV)	Detector Type
1	0.173	9.753	27.480	37.233	-27.561	64.794	QUASPEAK
2	0.173	9.753	2.330	12.083	-42.711	54.794	AVERAGE
3	0.420	9.749	31.250	40.999	-16.458	57.457	QUASPEAK
4	* 0.420	9.749	25.330	35.079	-12.378	47.457	AVERAGE
5	0.795	9.789	22.160	31.949	-24.051	56.000	QUASPEAK
6	0.795	9.789	14.450	24.239	-21.761	46.000	AVERAGE
7	2.103	9.850	21.980	31.830	-24.170	56.000	QUASPEAK
8	2.103	9.850	11.450	21.300	-24.700	46.000	AVERAGE
9	4.478	9.849	21.800	31.649	-24.351	56.000	QUASPEAK
10	4.478	9.849	14.450	24.299	-21.701	46.000	AVERAGE
11	12.033	10.215	22.380	32.595	-27.405	60.000	QUASPEAK
12	12.033	10.215	15.530	25.745	-24.255	50.000	AVERAGE

Note:

1. All Reading Levels are Quasi-Peak and average value.
2. " * ", means this data is the worst emission level.
3. Measurement Level = Reading Level + Correct Factor.

3. 99% & DTS Bandwidth

3.1. Test Equipment

The following test equipments are used during the radiated emission tests:

99% & DTS Bandwidth / SR10-H

Instrument	Manufacturer	Model No.	Serial No	Next Cal. Date
EXA Signal Analyzer	Keysight	N9010A	MY51440132	2018/03/12

Note: All equipments that need to calibrate are with calibration period of 1 year.

3.2. Test Setup

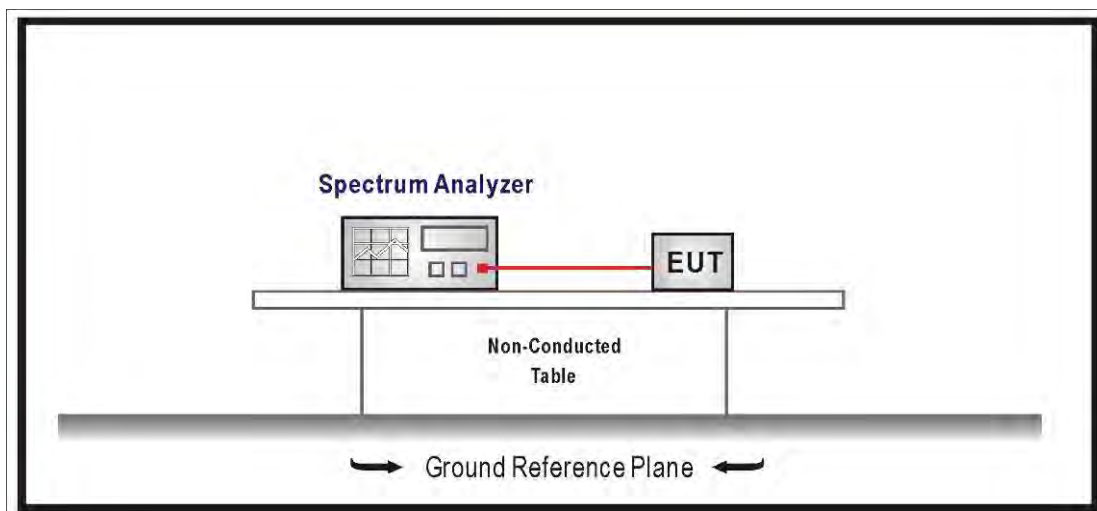

3.3. Limits

99% Bandwidth : No Required

6dB Bandwidth \geq 500KHz

3.4. Test Procedure

99% Bandwidth :

The EUT was tested according to U-NII test procedure of KDB 789033 V01r03.

Set RBW 1% of the emission bandwidth, VBW equal to 3 times the RBW.

DTS Bandwidth :

Set RBW = 100KHz, VBW \geq 3xRBW, Sweep time=Auto, Set Peak detector.

3.5. Uncertainty

The measurement uncertainty is defined as $\pm 150\text{Hz}$

3.6. Test Result

Product	Lyra		
Test Item	99% Bandwidth		
Test Mode	Mode 1: Tx-AD2055320 Mode		
Date of Test	2017/04/08	Test Site	SR10-H

IEEE 802.11a (ANT 0)			
Channel No.	Frequency (MHz)	Measure Value (MHz)	Limit (MHz)
36	5180	16.896	--
44	5220	16.746	--
48	5240	16.692	--

Channel 36 (5180MHz)

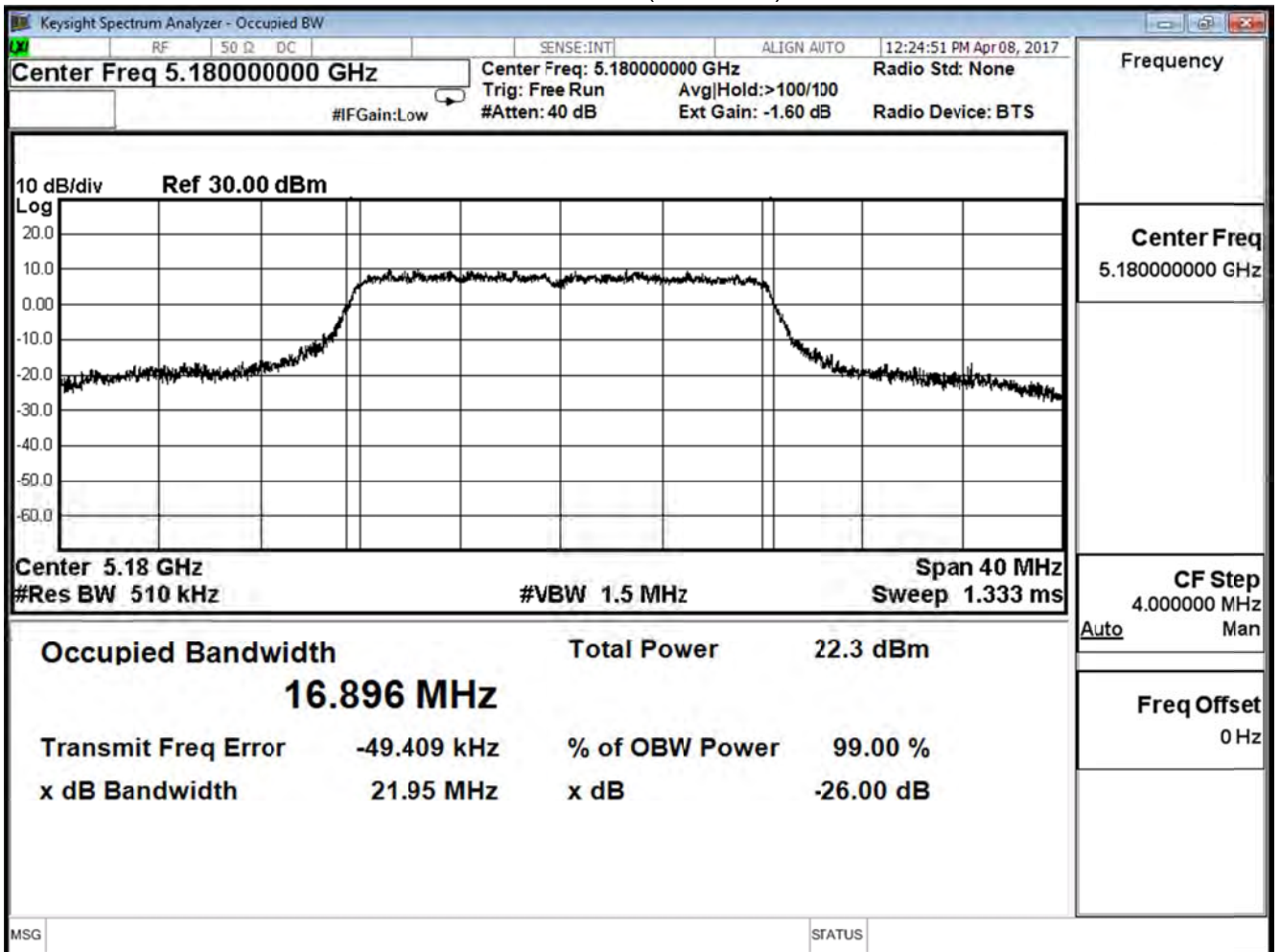

Channel 44 (5220MHz)

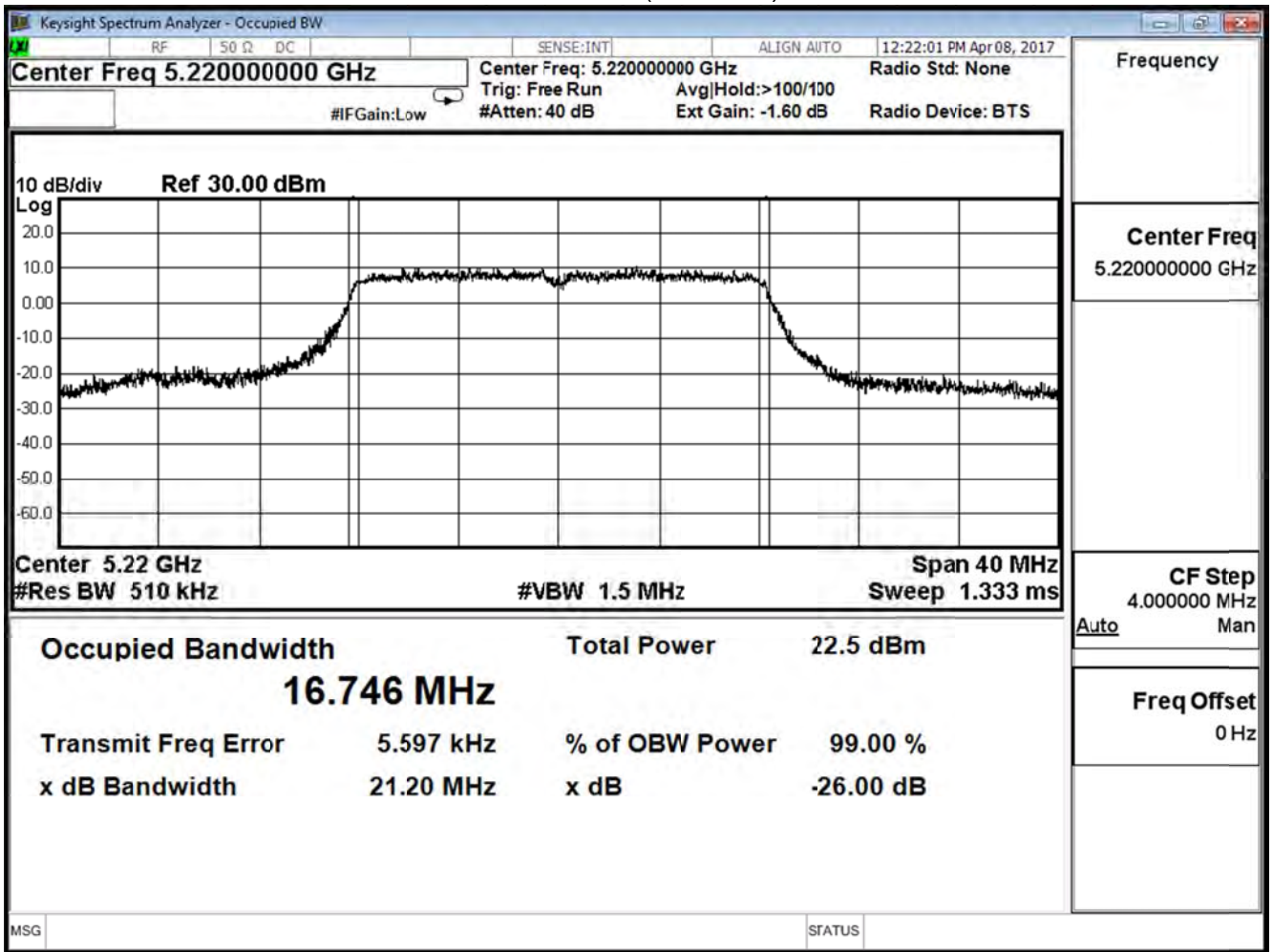

Channel 48 (5240MHz)

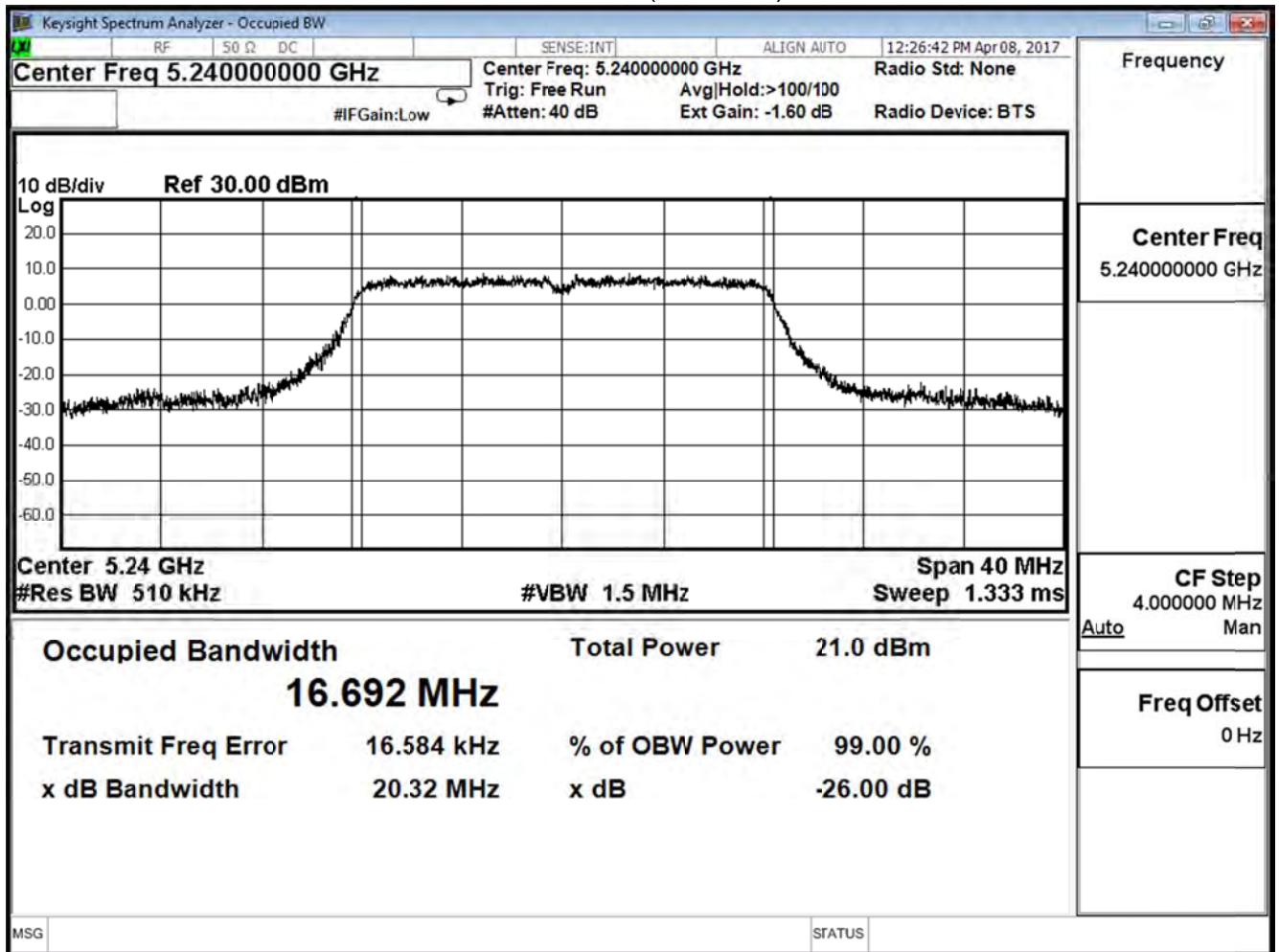

Product	Lyra		
Test Item	99% Bandwidth		
Test Mode	Mode 1: Tx-AD2055320 Mode		
Date of Test	2017/04/08	Test Site	SR10-H

IEEE 802.11a (ANT 1)

Channel No.	Frequency (MHz)	Measure Value (MHz)	Limit (MHz)
36	5180	16.674	--
44	5220	16.717	--
48	5240	16.637	--

Channel 36 (5180MHz)

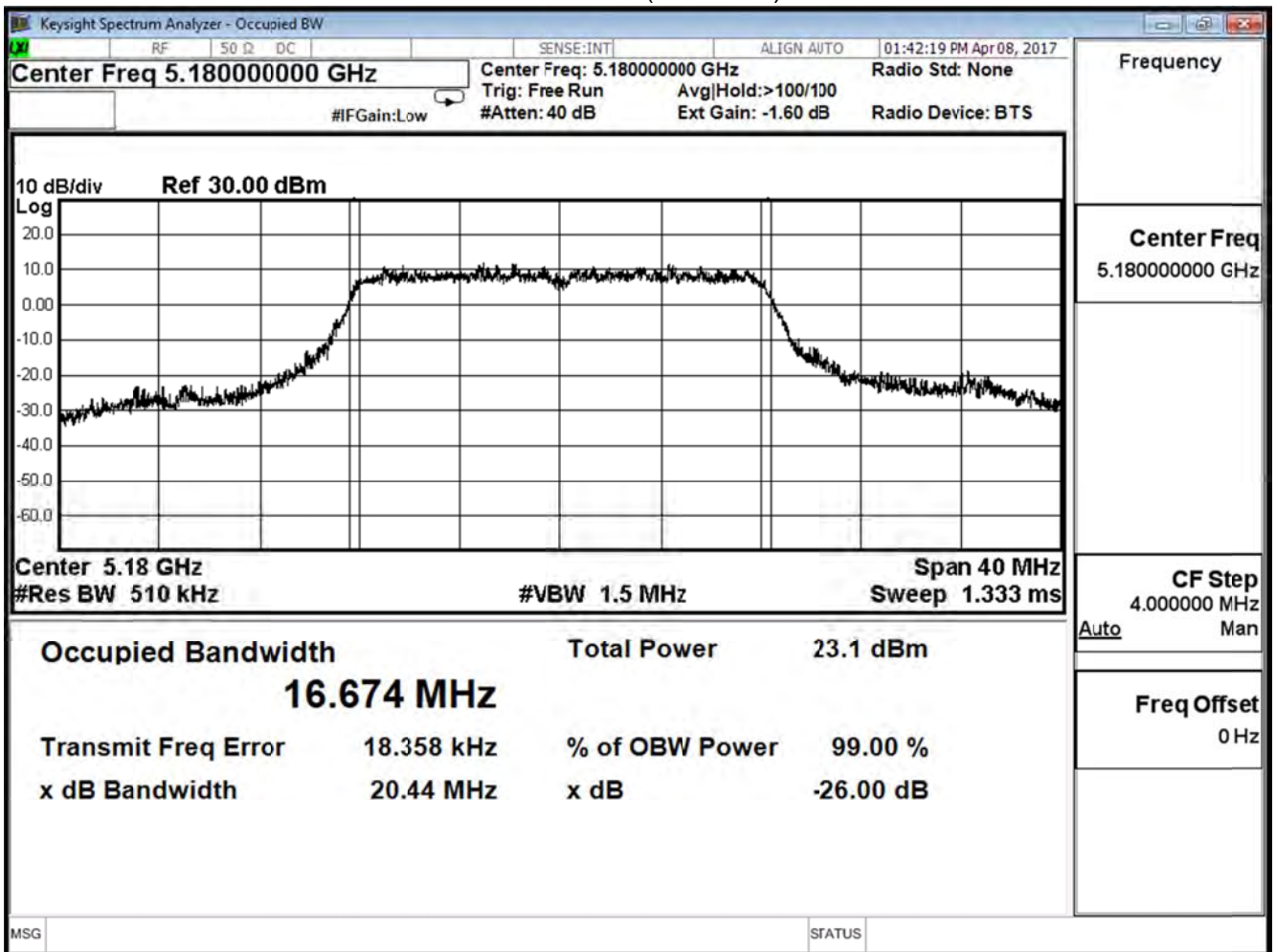

Channel 44 (5220MHz)

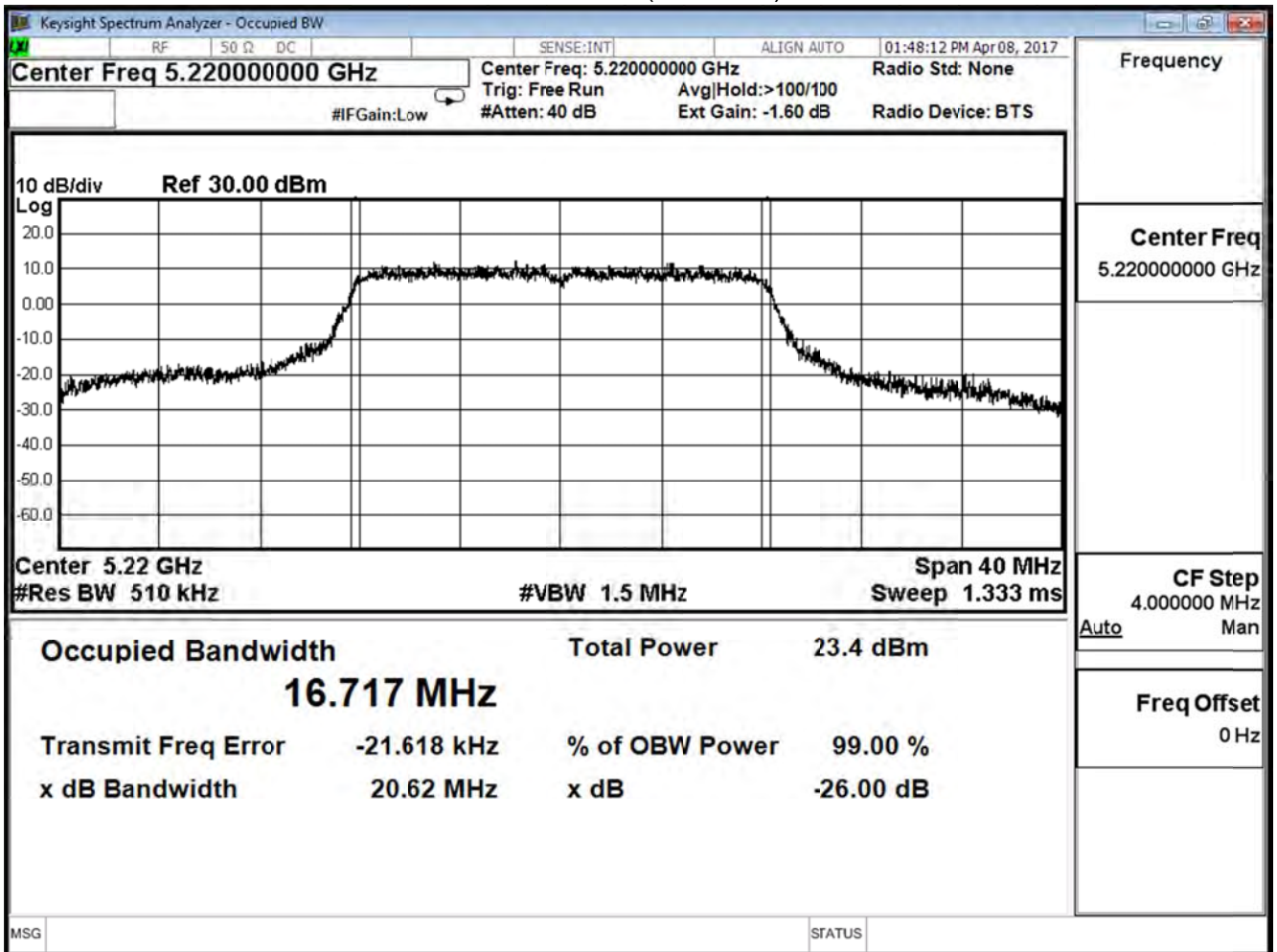

Channel 48 (5240MHz)

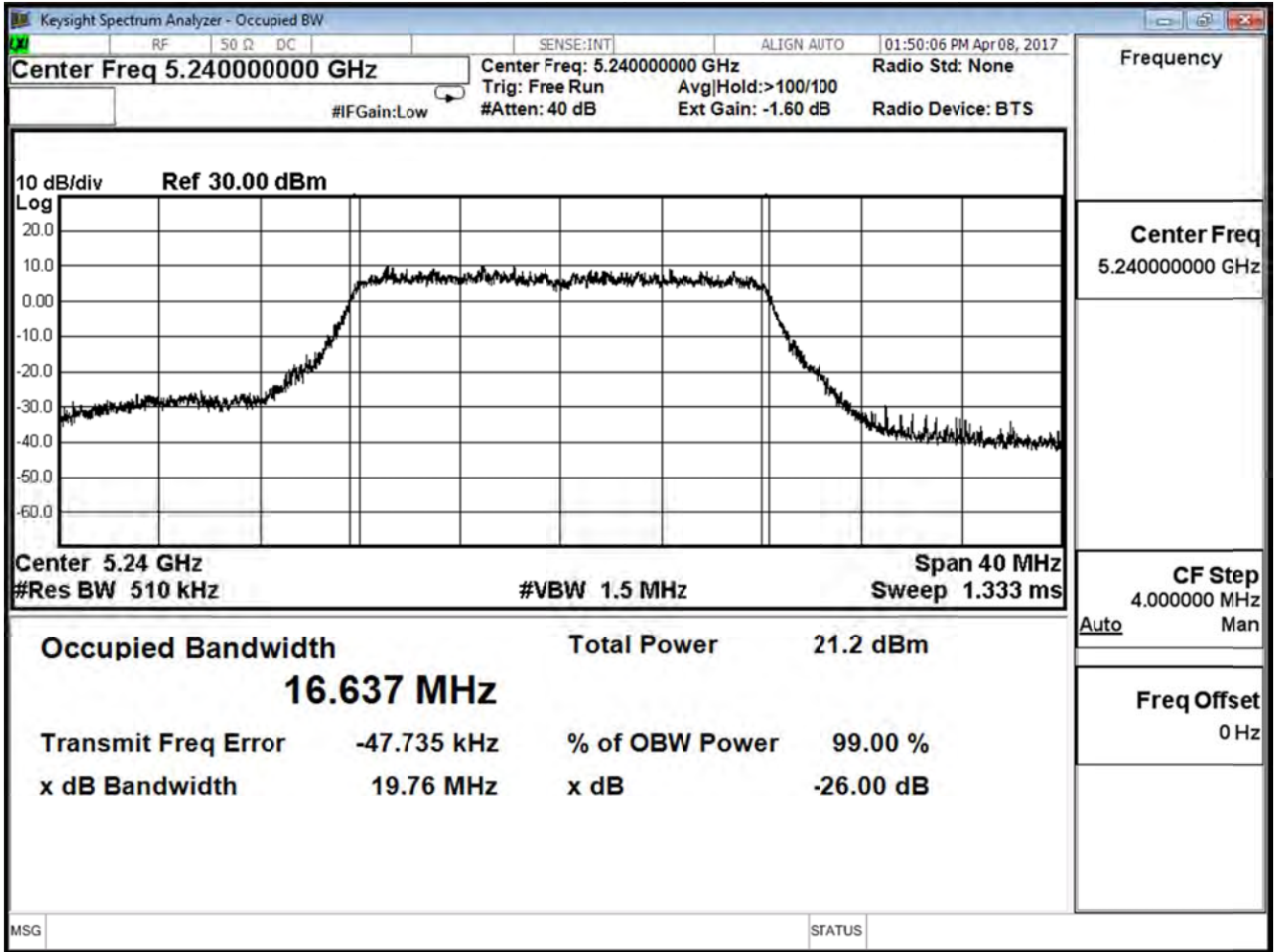

Product	Lyra		
Test Item	99% Bandwidth		
Test Mode	Mode 1: Tx-AD2055320 Mode		
Date of Test	2017/04/08	Test Site	SR10-H

IEEE 802.11n20 (ANT 0)			
Channel No.	Frequency (MHz)	Measure Value (MHz)	Limit (MHz)
36	5180	18.677	--
44	5220	17.928	--
48	5240	18.603	--

Channel 36 (5180MHz)

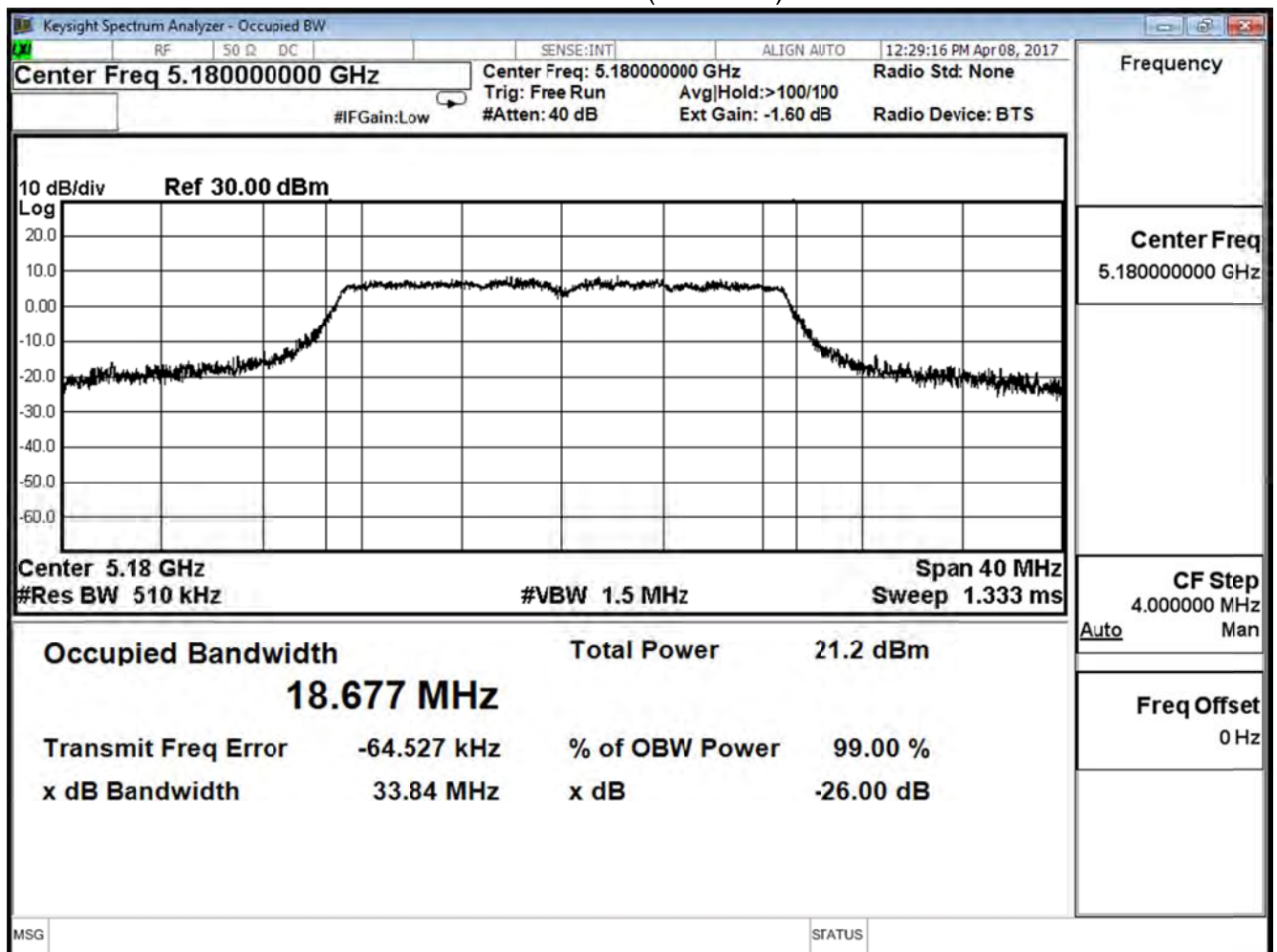

Channel 44 (5220MHz)

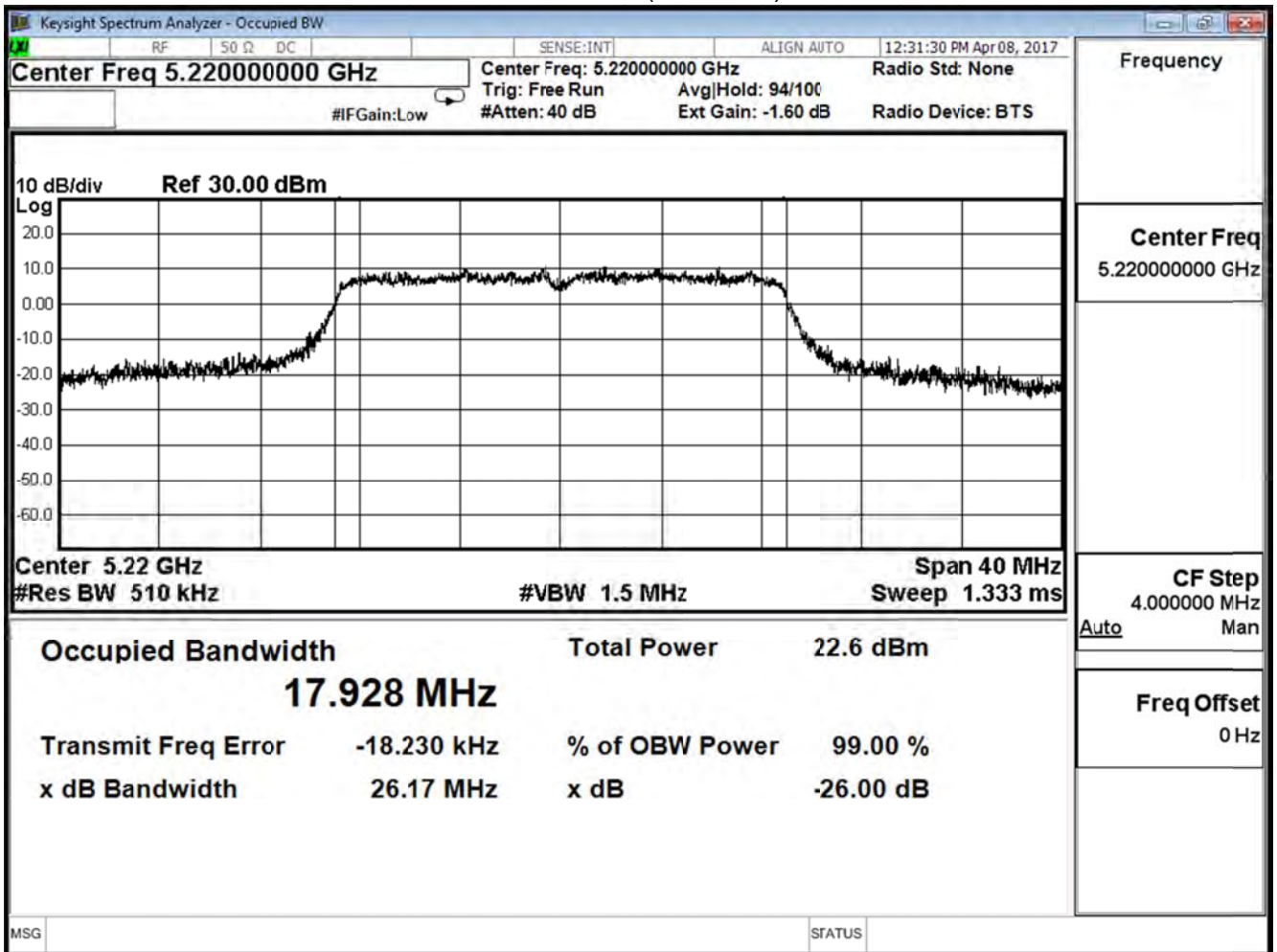

Channel 48 (5240MHz)

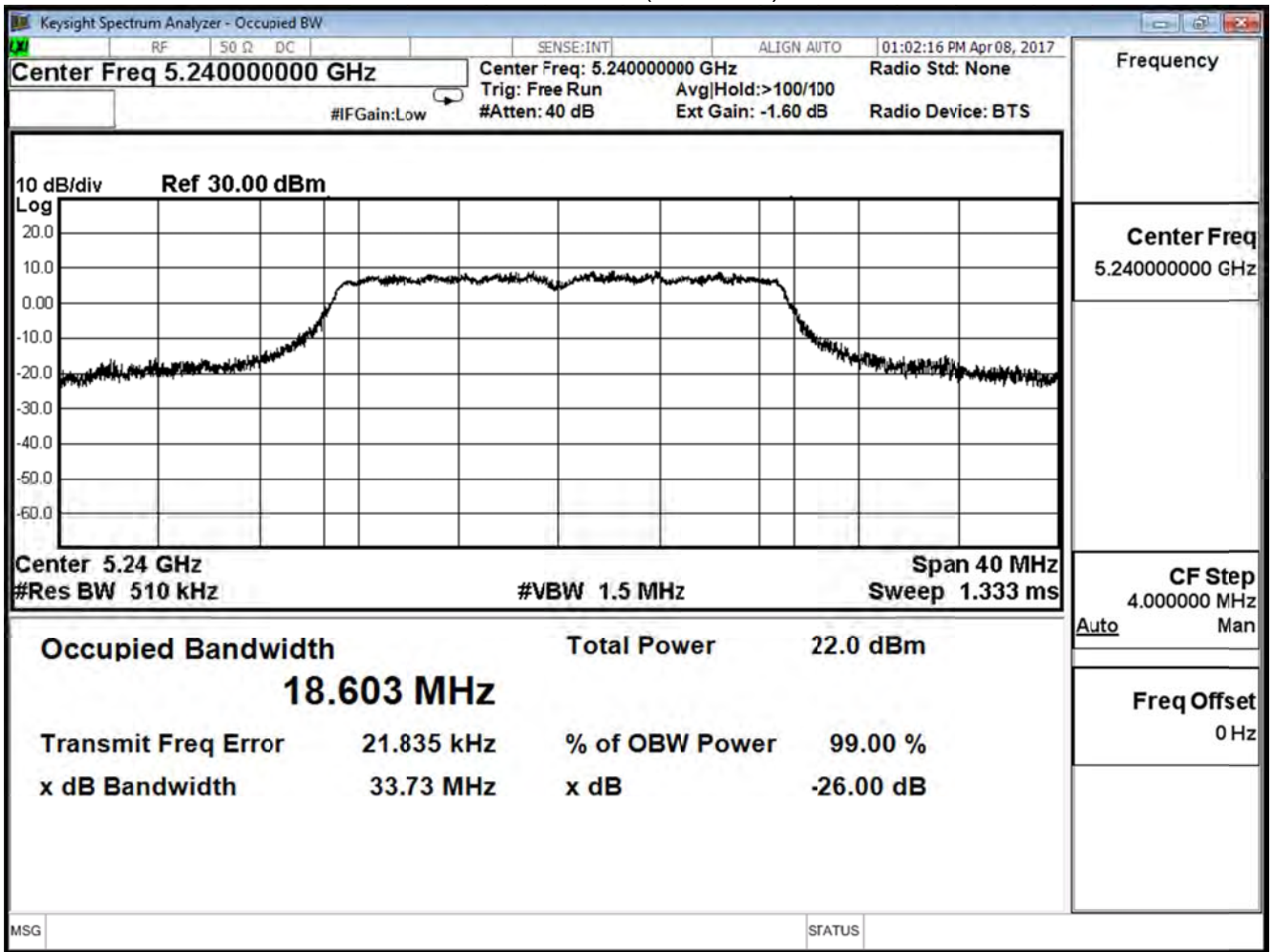

Product	Lyra		
Test Item	99% Bandwidth		
Test Mode	Mode 1: Tx-AD2055320 Mode		
Date of Test	2017/04/08	Test Site	SR10-H

IEEE 802.11n20 (ANT 1)			
Channel No.	Frequency (MHz)	Measure Value (MHz)	Limit (MHz)
36	5180	18.366	--
44	5220	18.961	--
48	5240	17.773	--

Channel 36 (5180MHz)

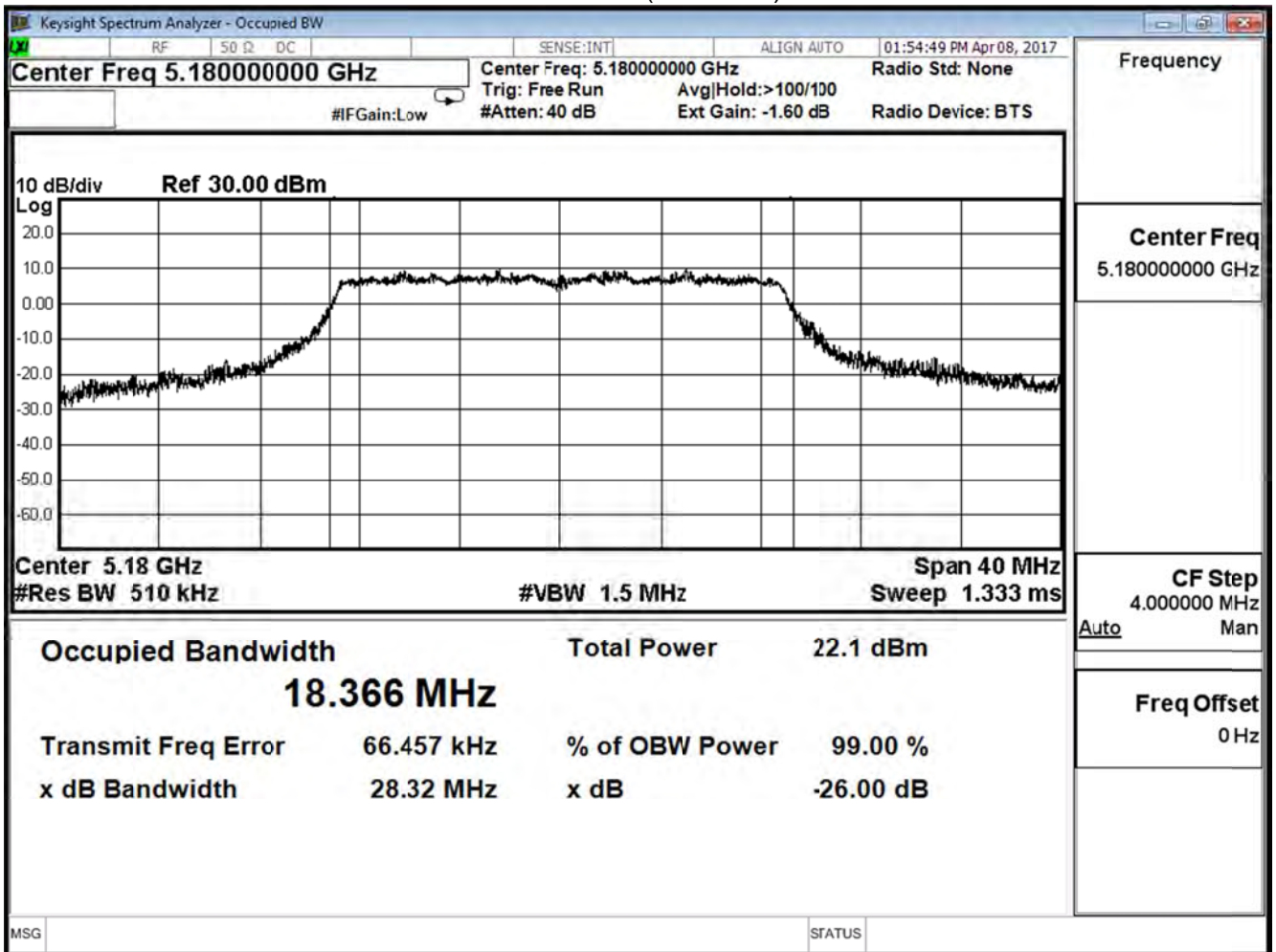

Channel 44 (5220MHz)

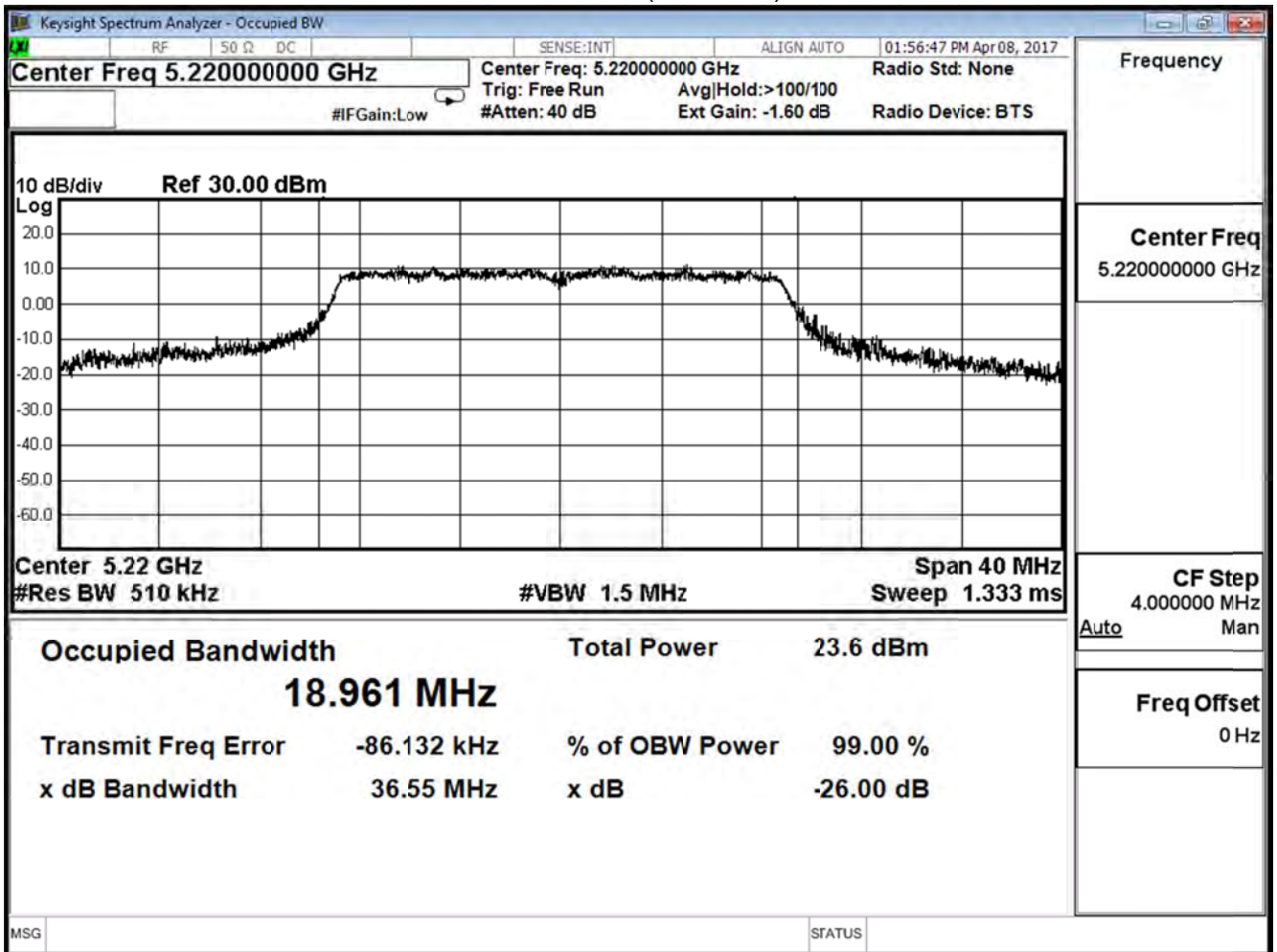

Channel 48 (5240MHz)

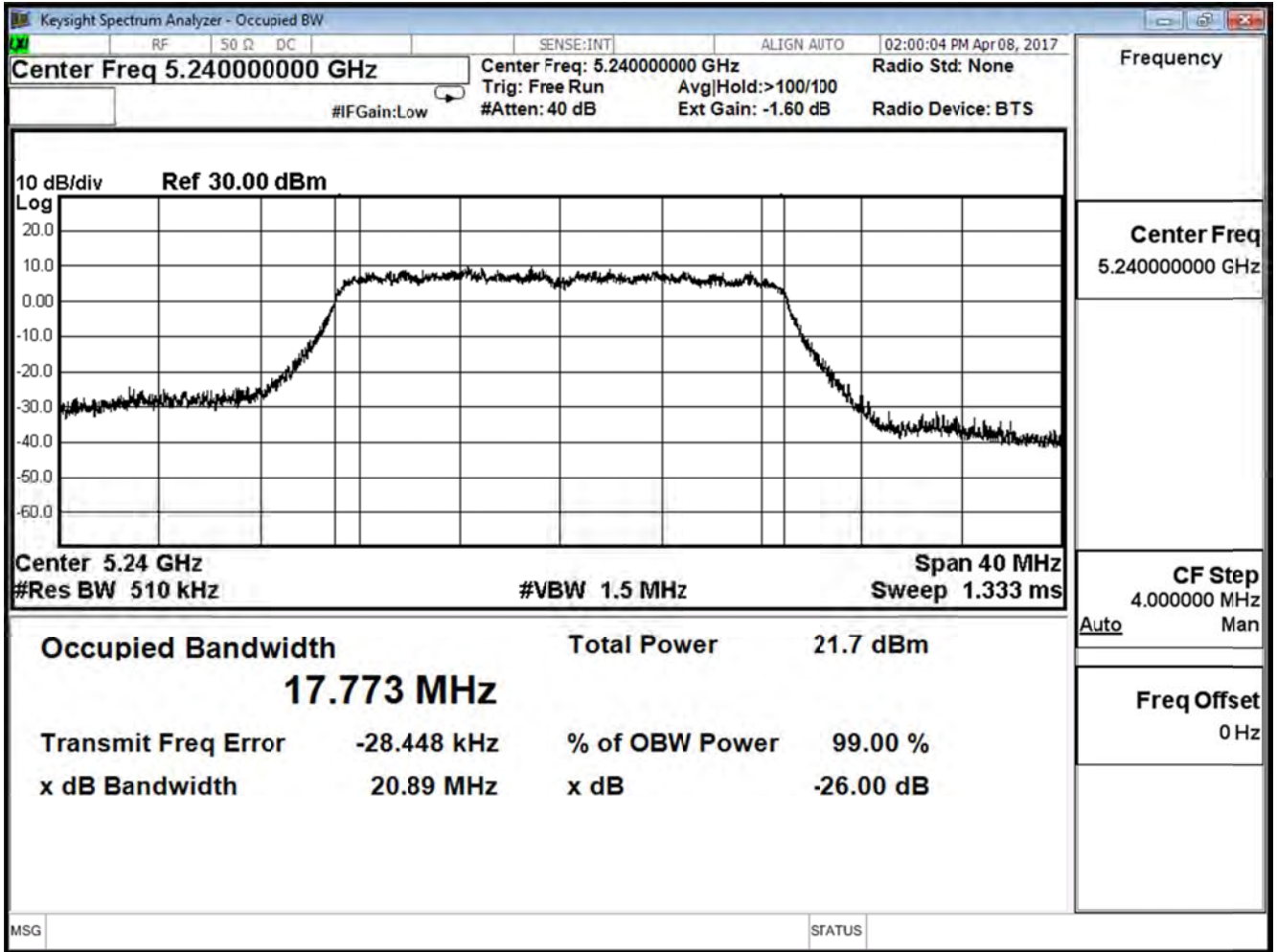

Product	Lyra		
Test Item	99% Bandwidth		
Test Mode	Mode 1: Tx-AD2055320 Mode		
Date of Test	2017/04/08	Test Site	SR10-H

IEEE 802.11n40 (ANT 0)			
Channel No.	Frequency (MHz)	Measure Value (MHz)	Limit (MHz)
38	5190	35.935	--
46	5230	36.471	--

Channel 38 (5190MHz)

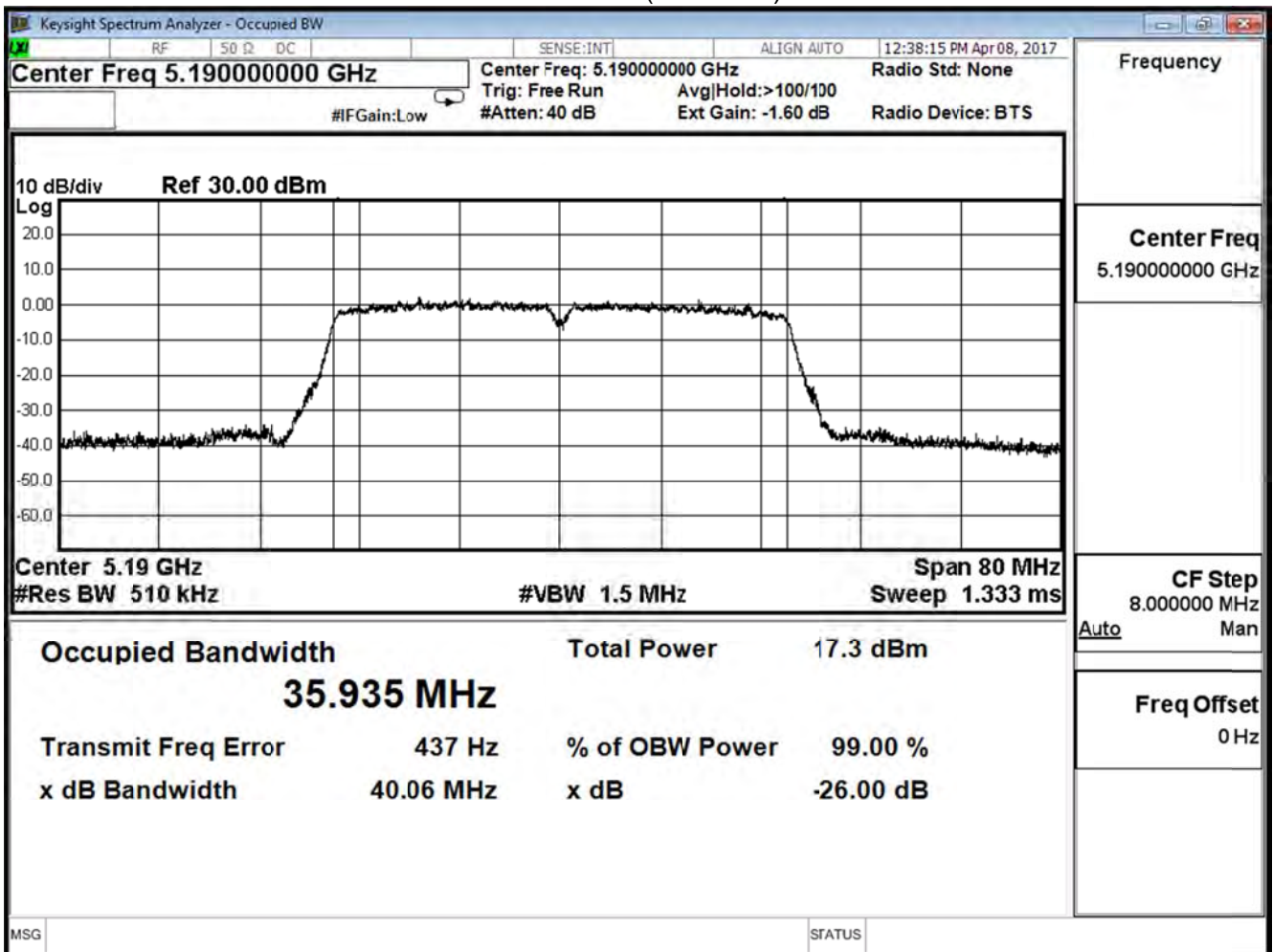

Channel 46 (5230MHz)

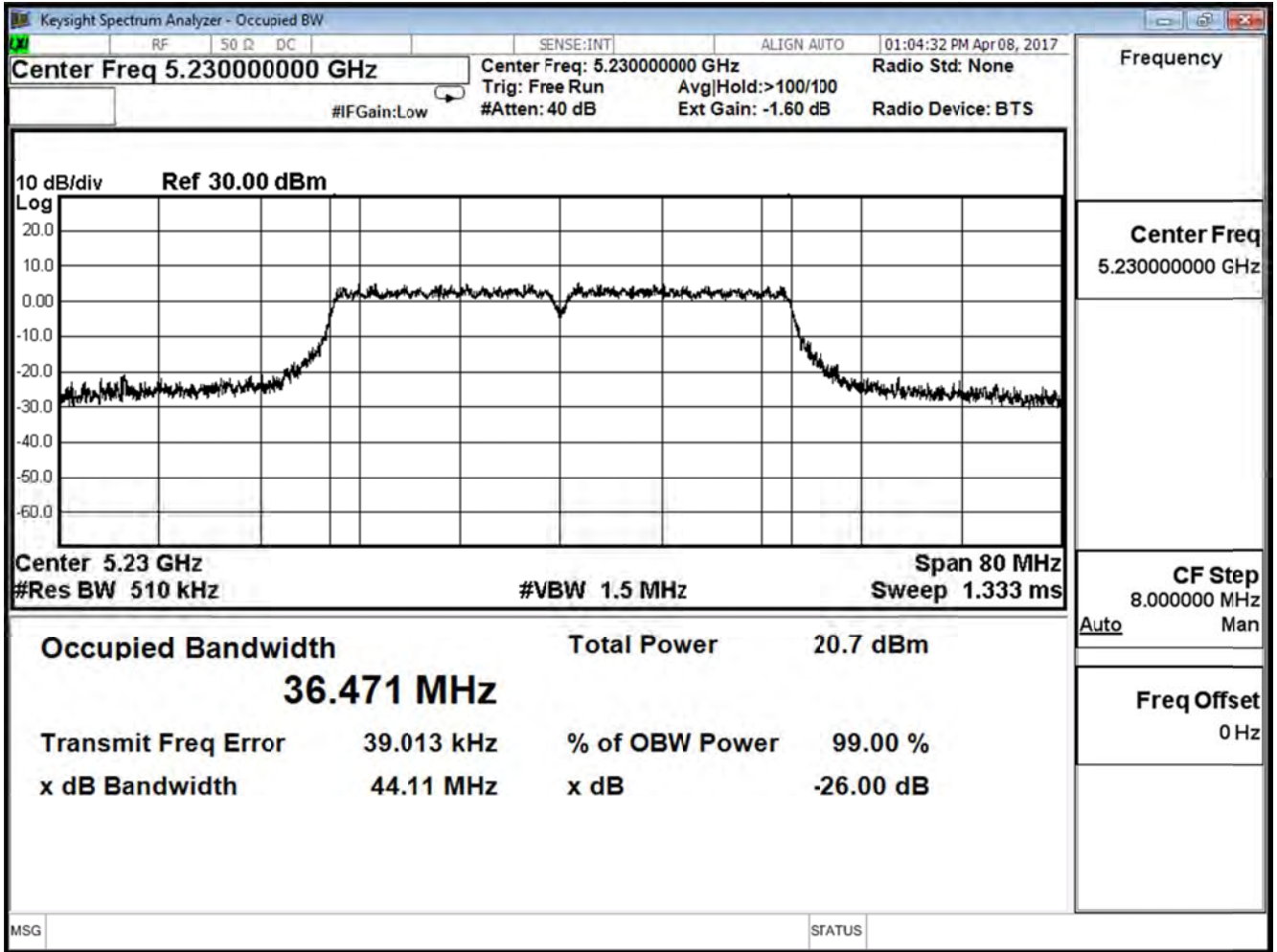

Product	Lyra		
Test Item	99% Bandwidth		
Test Mode	Mode 1: Tx-AD2055320 Mode		
Date of Test	2017/04/08	Test Site	SR10-H

IEEE 802.11n40 (ANT 1)			
Channel No.	Frequency (MHz)	Measure Value (MHz)	Limit (MHz)
38	5190	36.351	--
46	5230	36.389	--

Channel 38 (5190MHz)

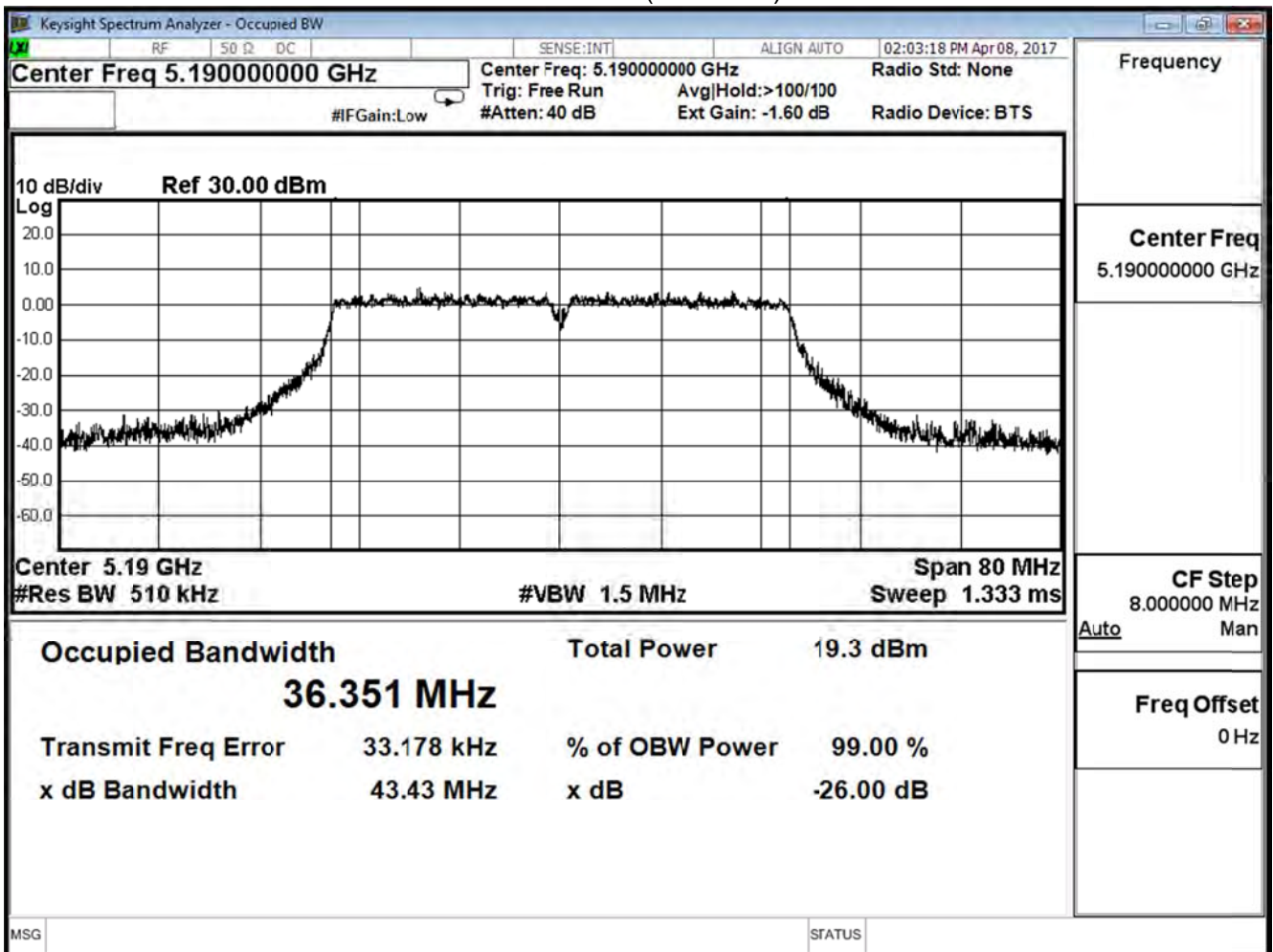

Channel 46 (5230MHz)

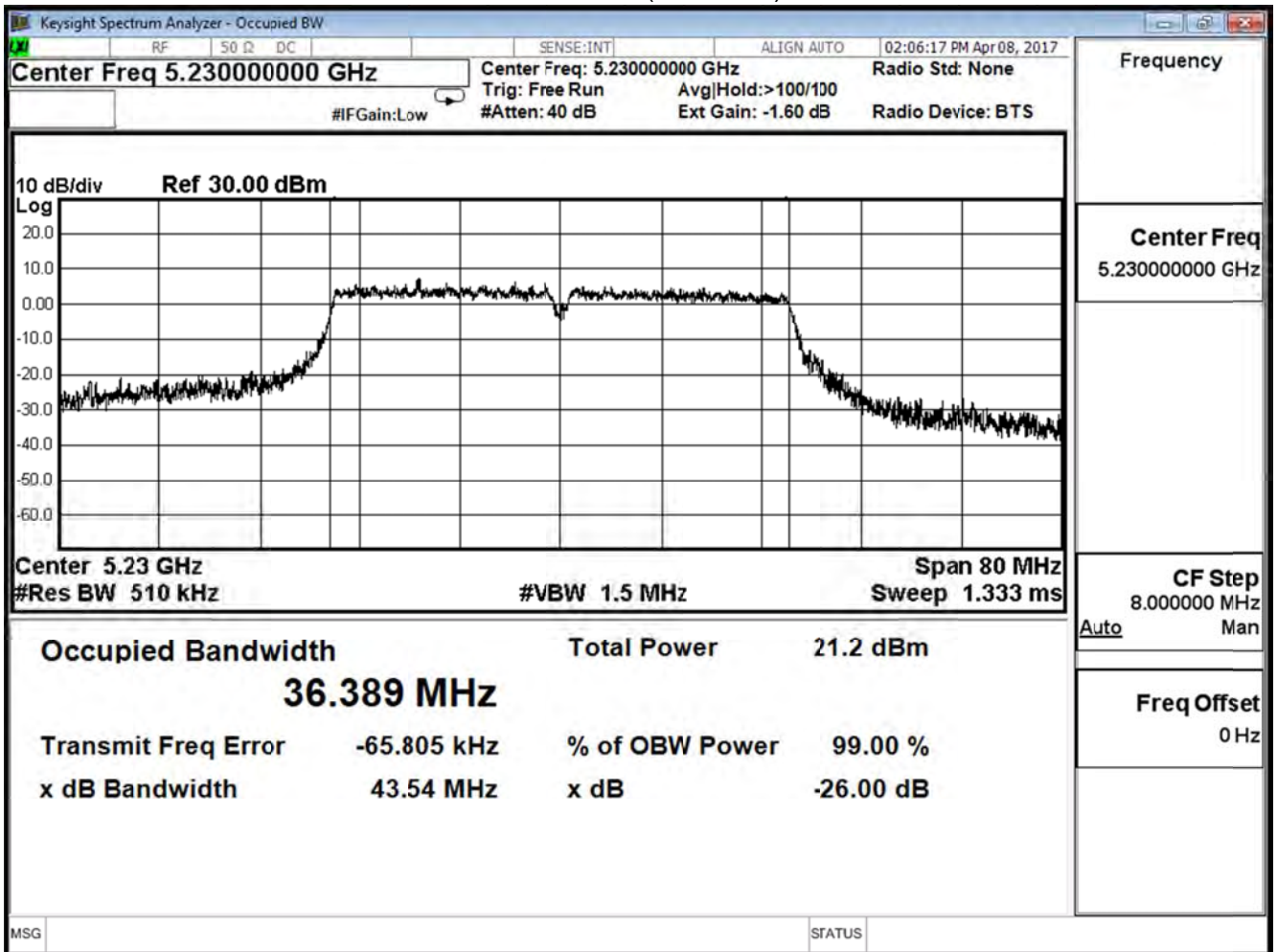

Product	Lyra		
Test Item	99% Bandwidth		
Test Mode	Mode 1: Tx-AD2055320 Mode		
Date of Test	2017/04/08	Test Site	SR10-H

IEEE 802.11ac80 (ANT 0)			
Channel No.	Frequency (MHz)	Measure Value (MHz)	Limit (MHz)
42	5210	76.365	--

Channel 42 (5210MHz)

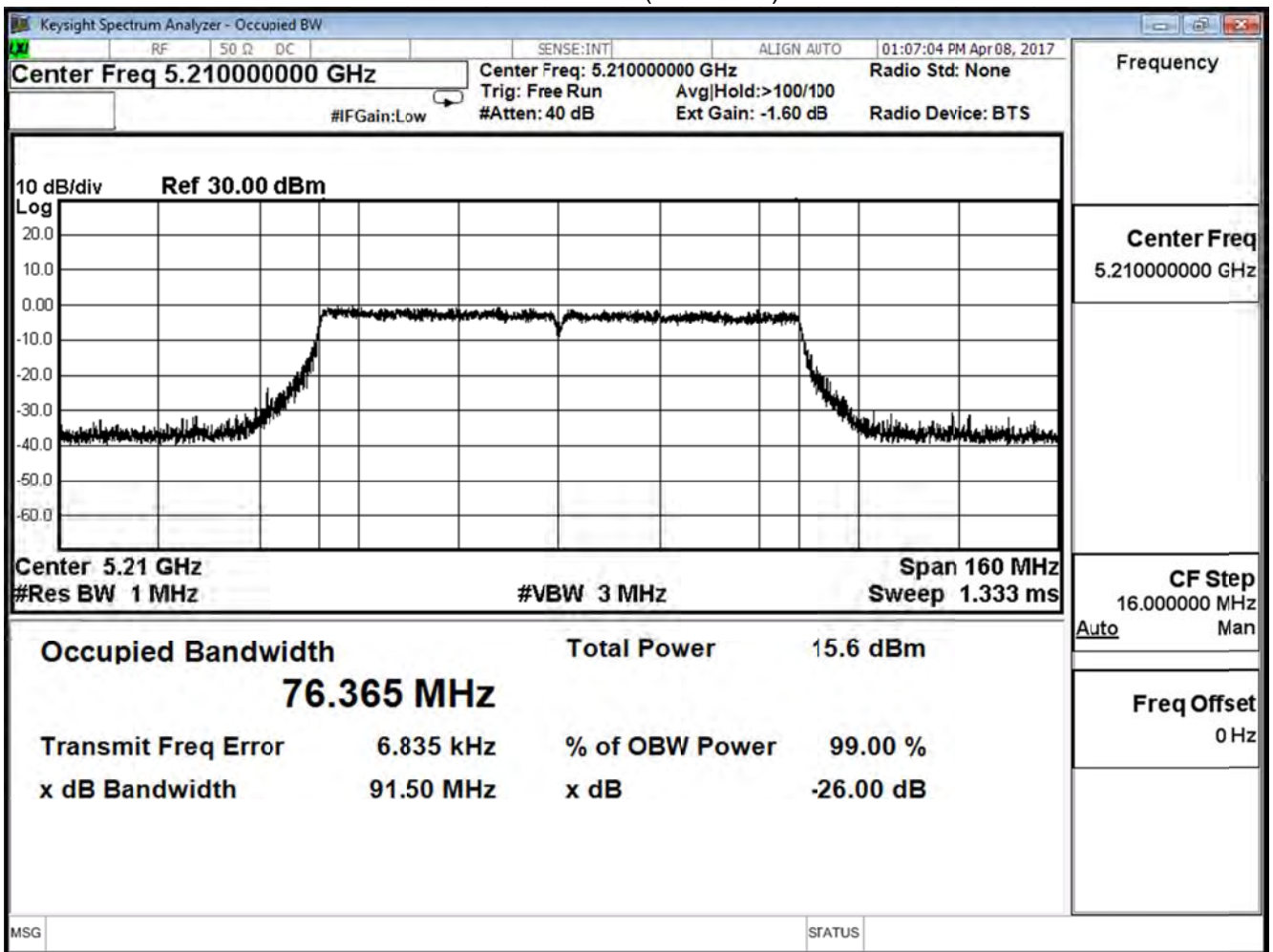

Product	Lyra		
Test Item	99% Bandwidth		
Test Mode	Mode 1: Tx-AD2055320 Mode		
Date of Test	2017/04/08	Test Site	SR10-H

IEEE 802.11ac80 (ANT 1)			
Channel No.	Frequency (MHz)	Measure Value (MHz)	Limit (MHz)
42	5210	75.863	--

Channel 42 (5210MHz)

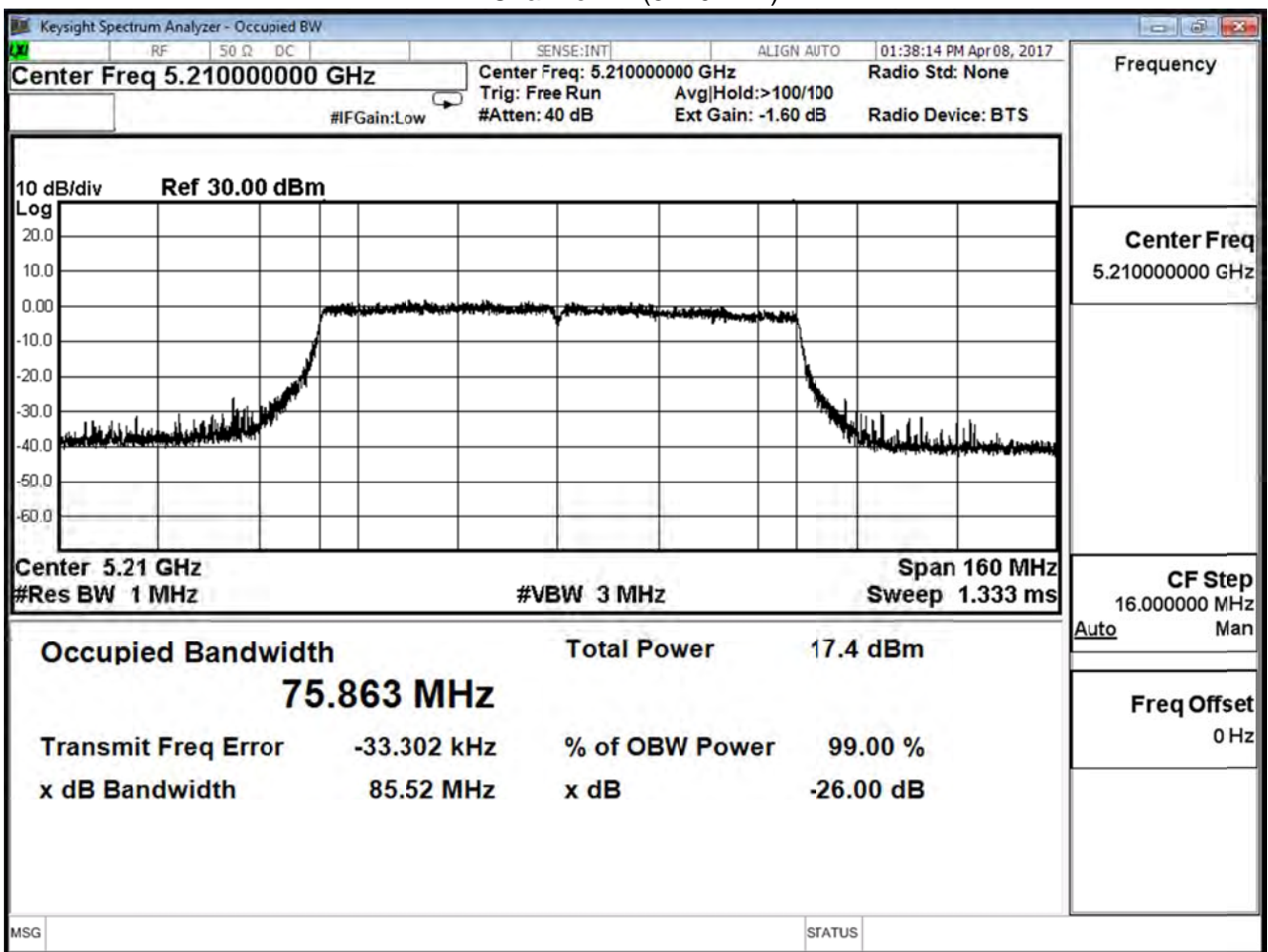

Product	Lyra		
Test Item	99% Bandwidth		
Test Mode	Mode 1: Tx-AD2055320 Mode		
Date of Test	2017/04/08	Test Site	SR10-H

IEEE 802.11a (ANT 0)			
Channel No.	Frequency (MHz)	Measure Value (MHz)	Limit (MHz)
149	5745	19.924	--
157	5785	19.650	--
165	5825	21.317	--

Channel 149 (5745MH)

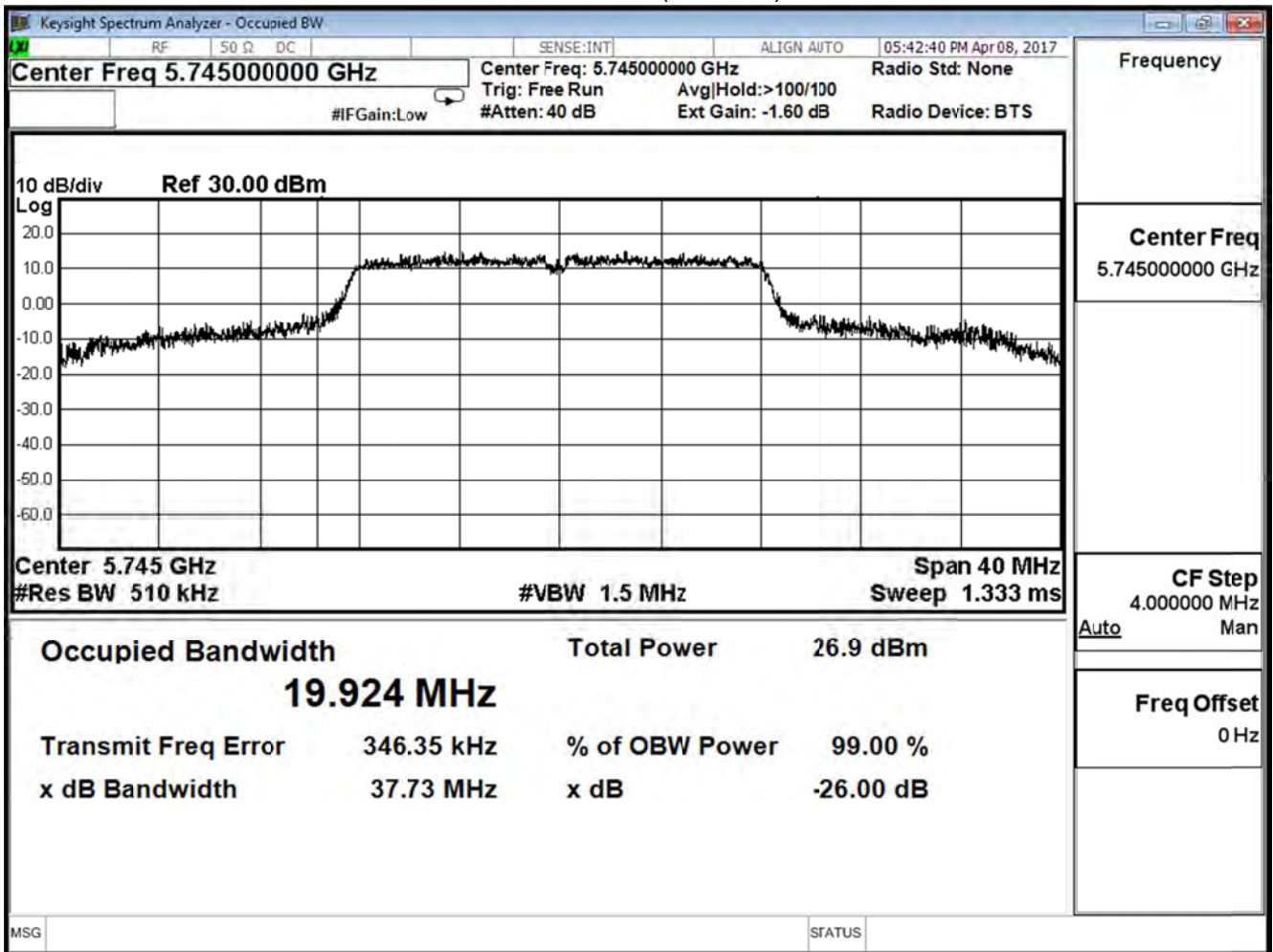

Channel 157 (5785MHz)

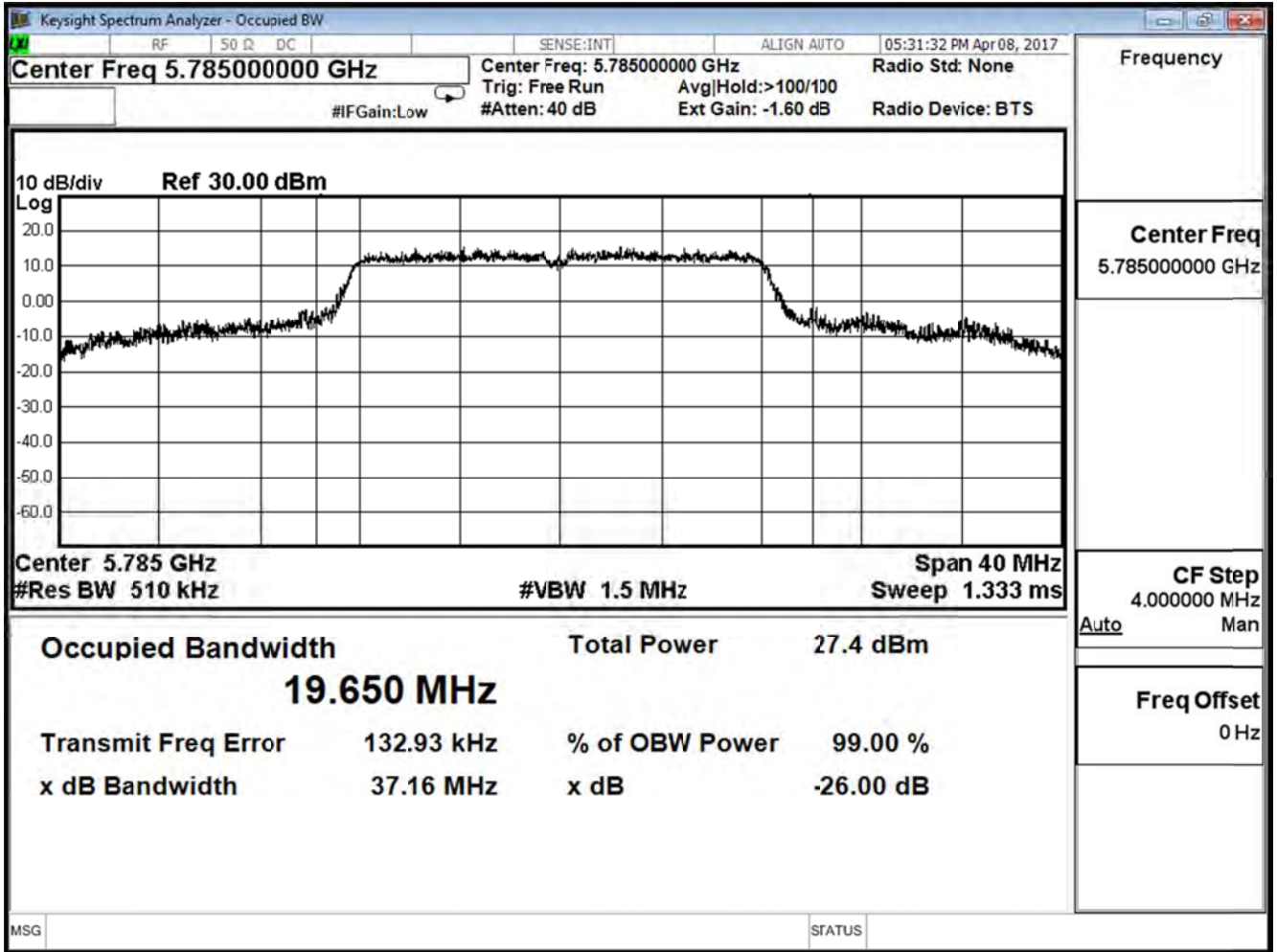

Channel 165 (5825MHz)

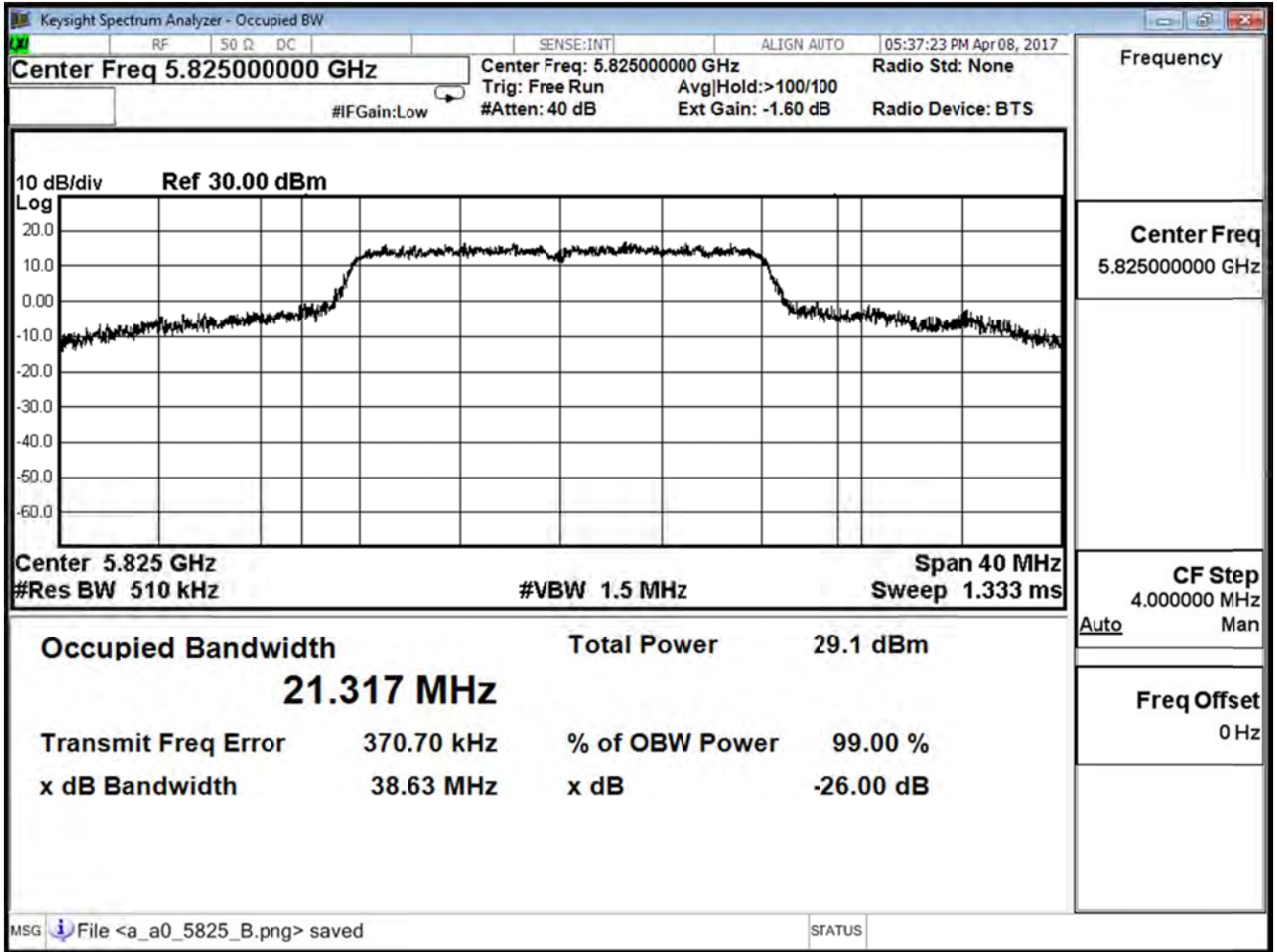

Product	Lyra		
Test Item	99% Bandwidth		
Test Mode	Mode 1: Tx-AD2055320 Mode		
Date of Test	2017/04/08	Test Site	SR10-H

IEEE 802.11a (ANT 1)			
Channel No.	Frequency (MHz)	Measure Value (MHz)	Limit (MHz)
149	5745	16.975	--
157	5785	17.056	--
165	5825	17.400	--

Channel 149 (5745MH)

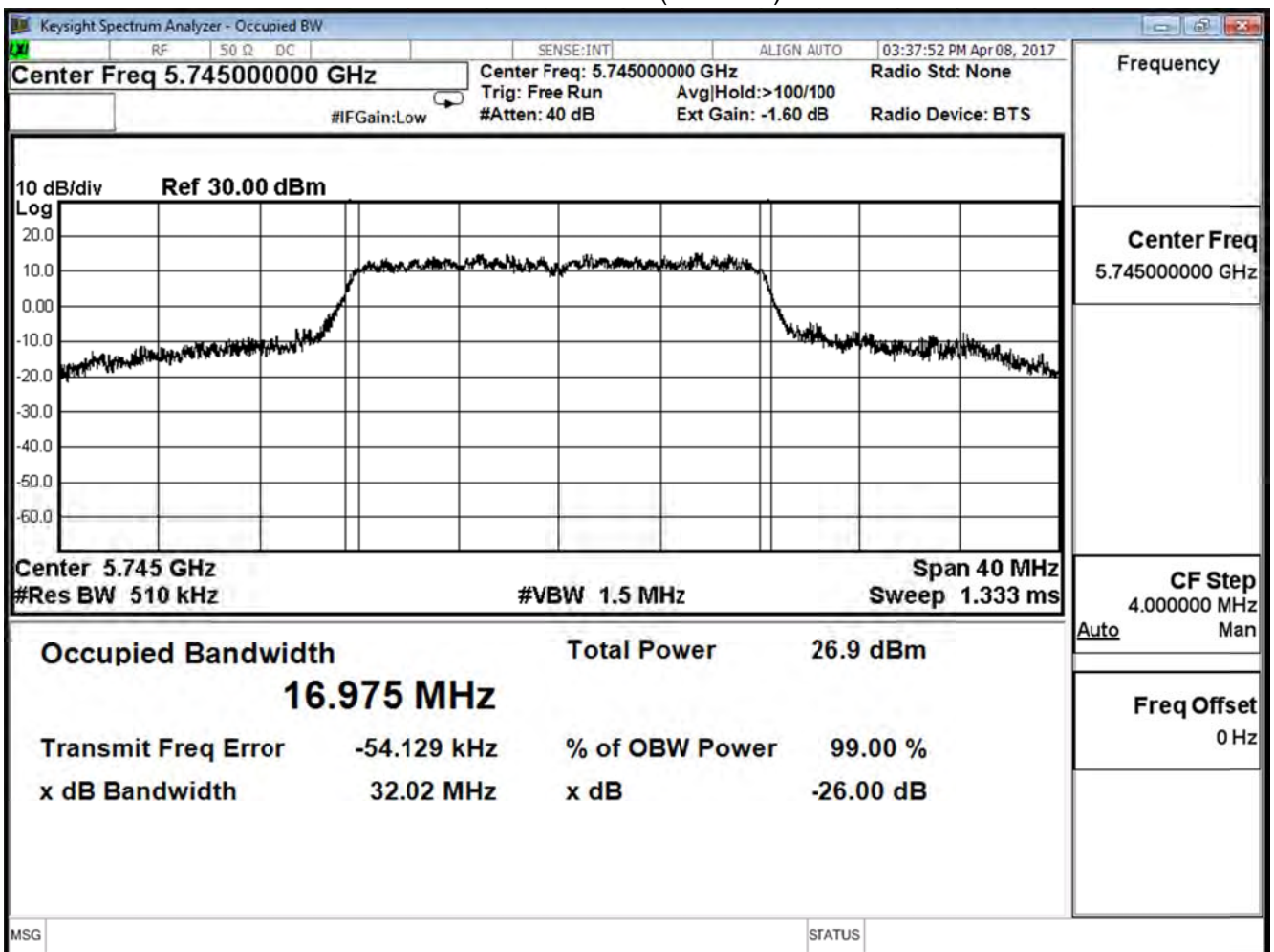

Channel 157 (5785MHz)

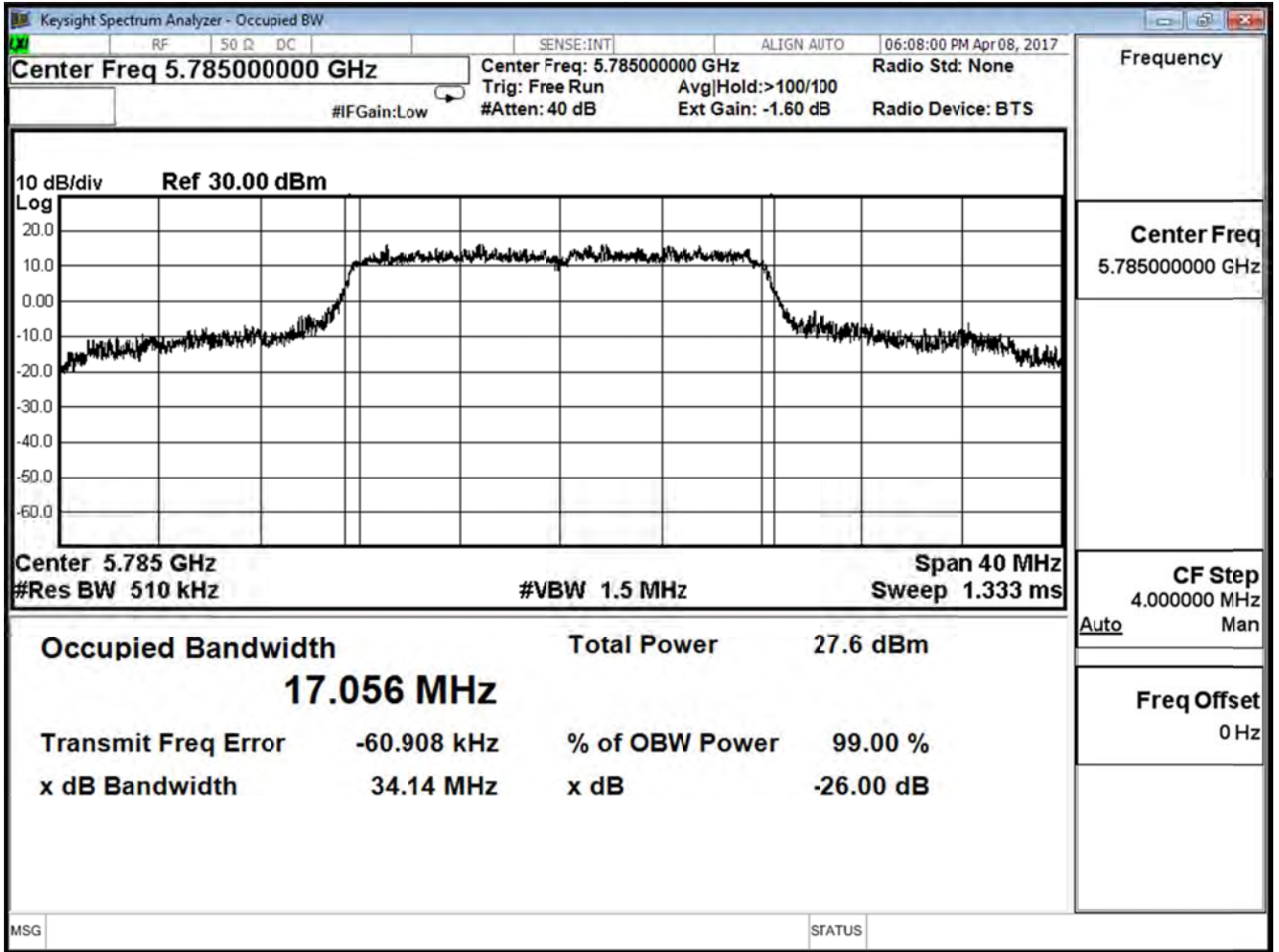

Channel 165 (5825MHz)

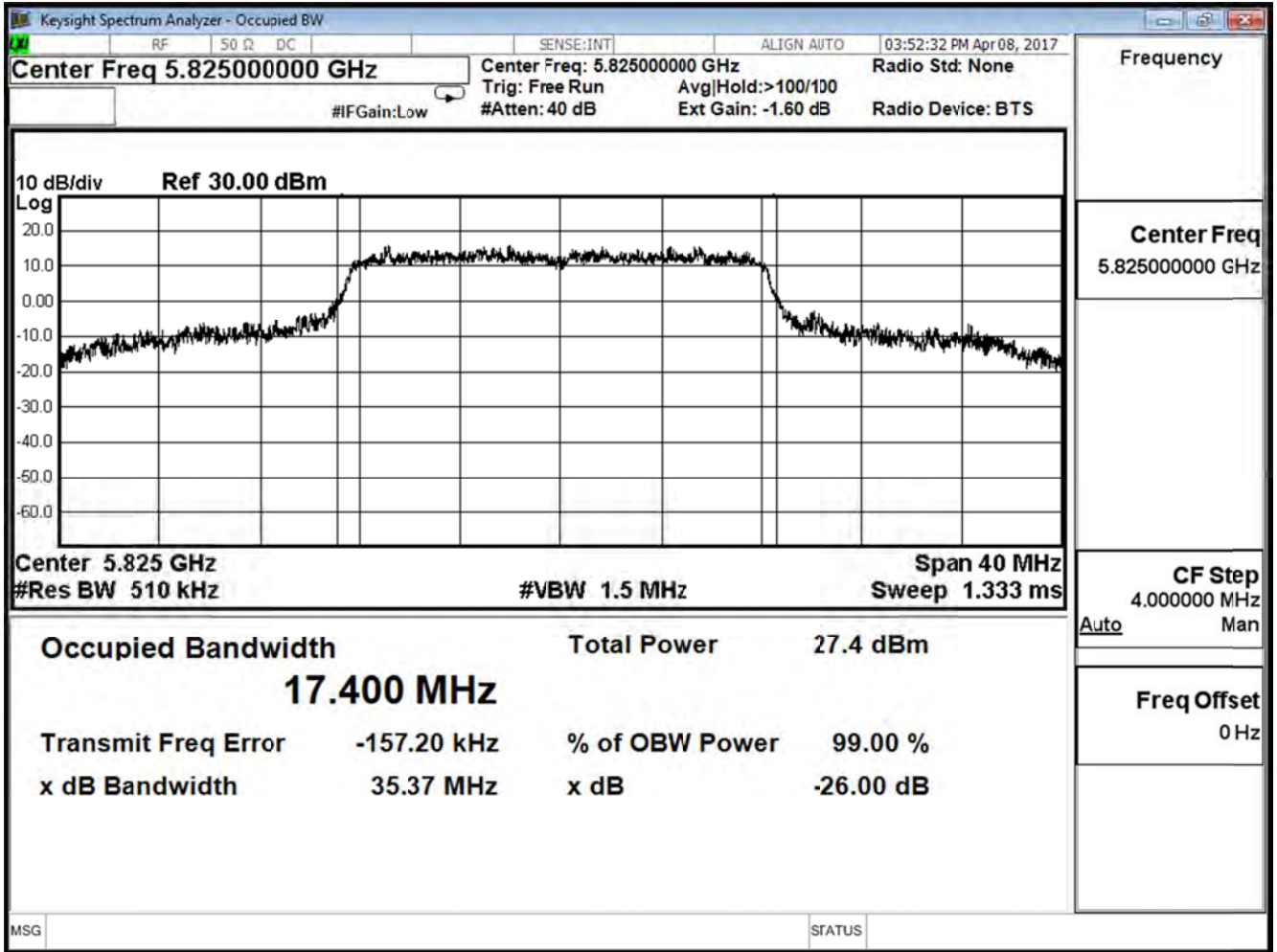

Product	Lyra		
Test Item	99% Bandwidth		
Test Mode	Mode 1: Tx-AD2055320 Mode		
Date of Test	2017/04/08	Test Site	SR10-H

IEEE 802.11n20 (ANT 0)			
Channel No.	Frequency (MHz)	Measure Value (MHz)	Limit (MHz)
149	5745	22.137	--
157	5785	21.462	--
165	5825	20.076	--

Channel 149 (5745MHz)

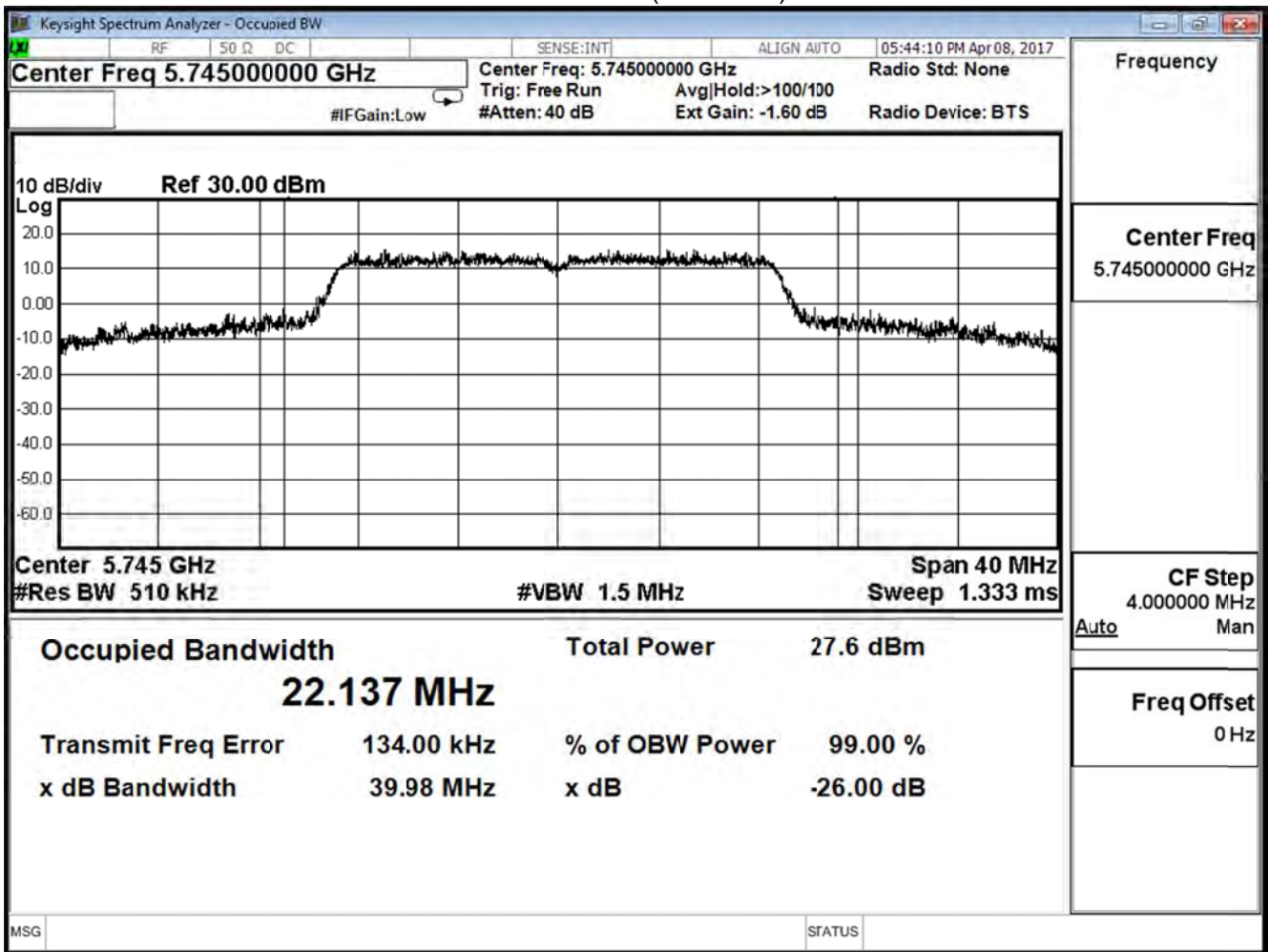

Channel 157 (5785MHz)

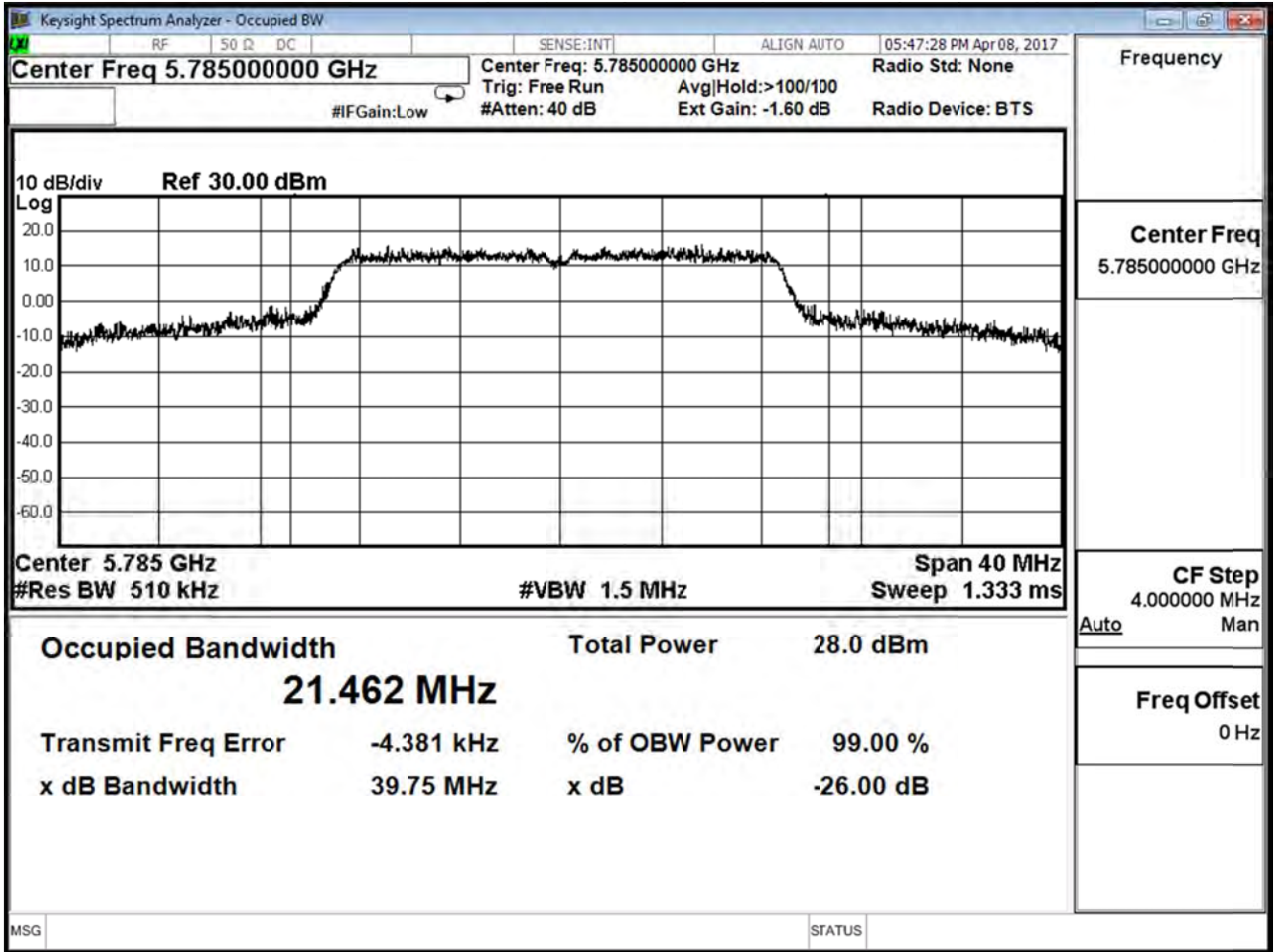

Channel 165 (5825MHz)

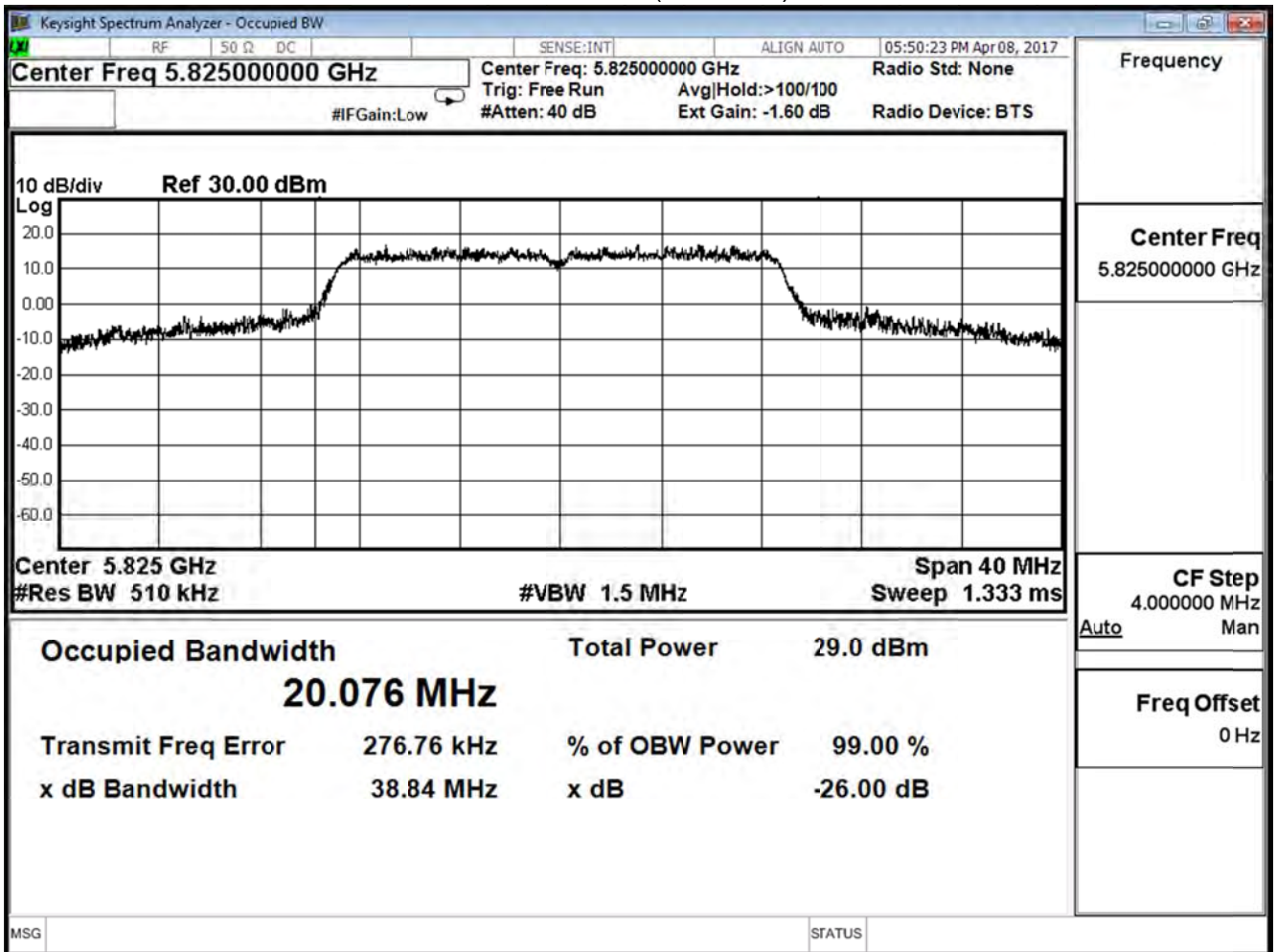

Product	Lyra		
Test Item	99% Bandwidth		
Test Mode	Mode 1: Tx-AD2055320 Mode		
Date of Test	2017/04/08	Test Site	SR10-H

IEEE 802.11n20 (ANT 1)			
Channel No.	Frequency (MHz)	Measure Value (MHz)	Limit (MHz)
149	5745	18.200	--
157	5785	18.225	--
165	5825	18.380	--

Channel 149 (5745MHz)

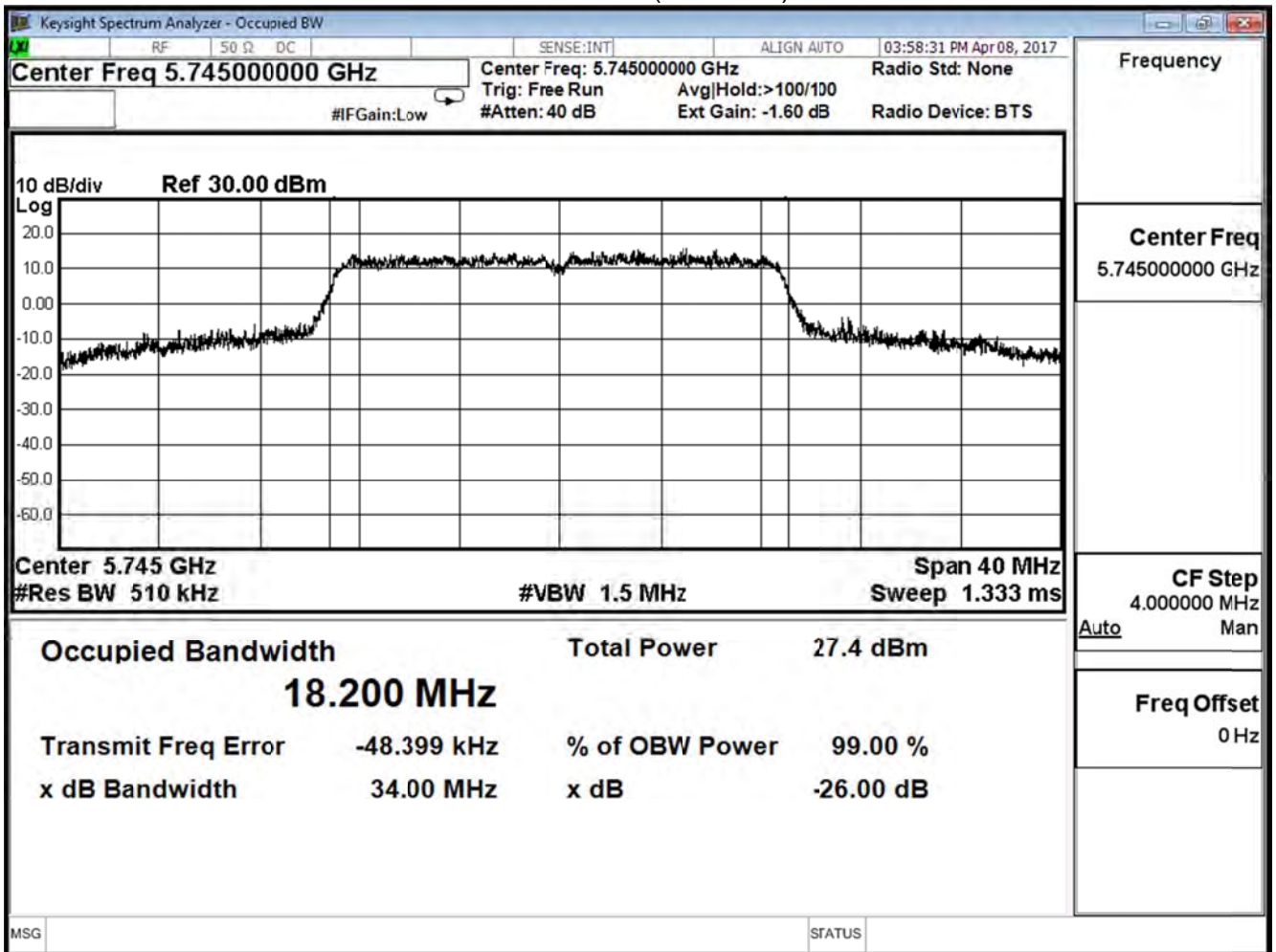

Channel 157 (5785MHz)

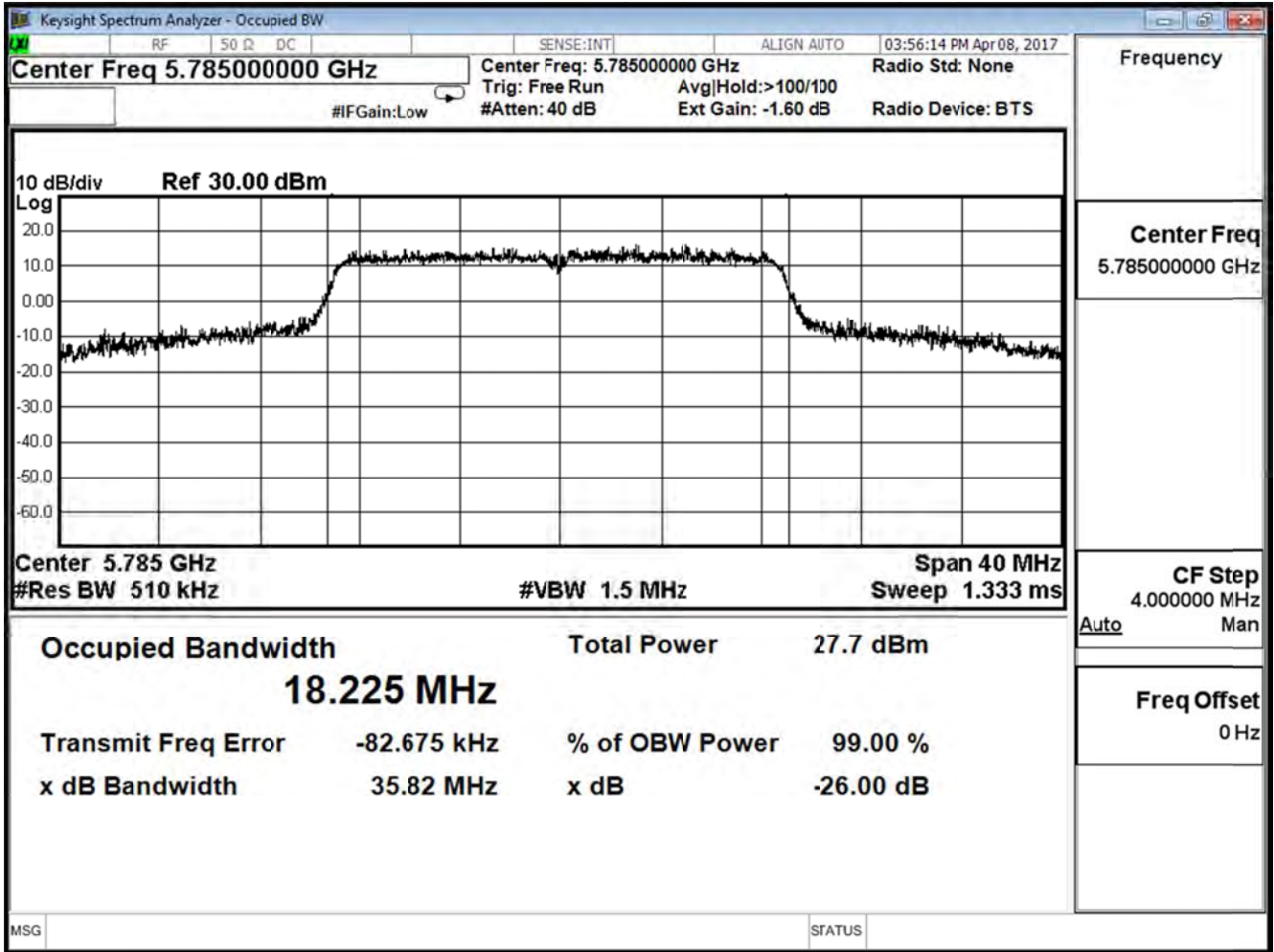

Channel 165 (5825MHz)

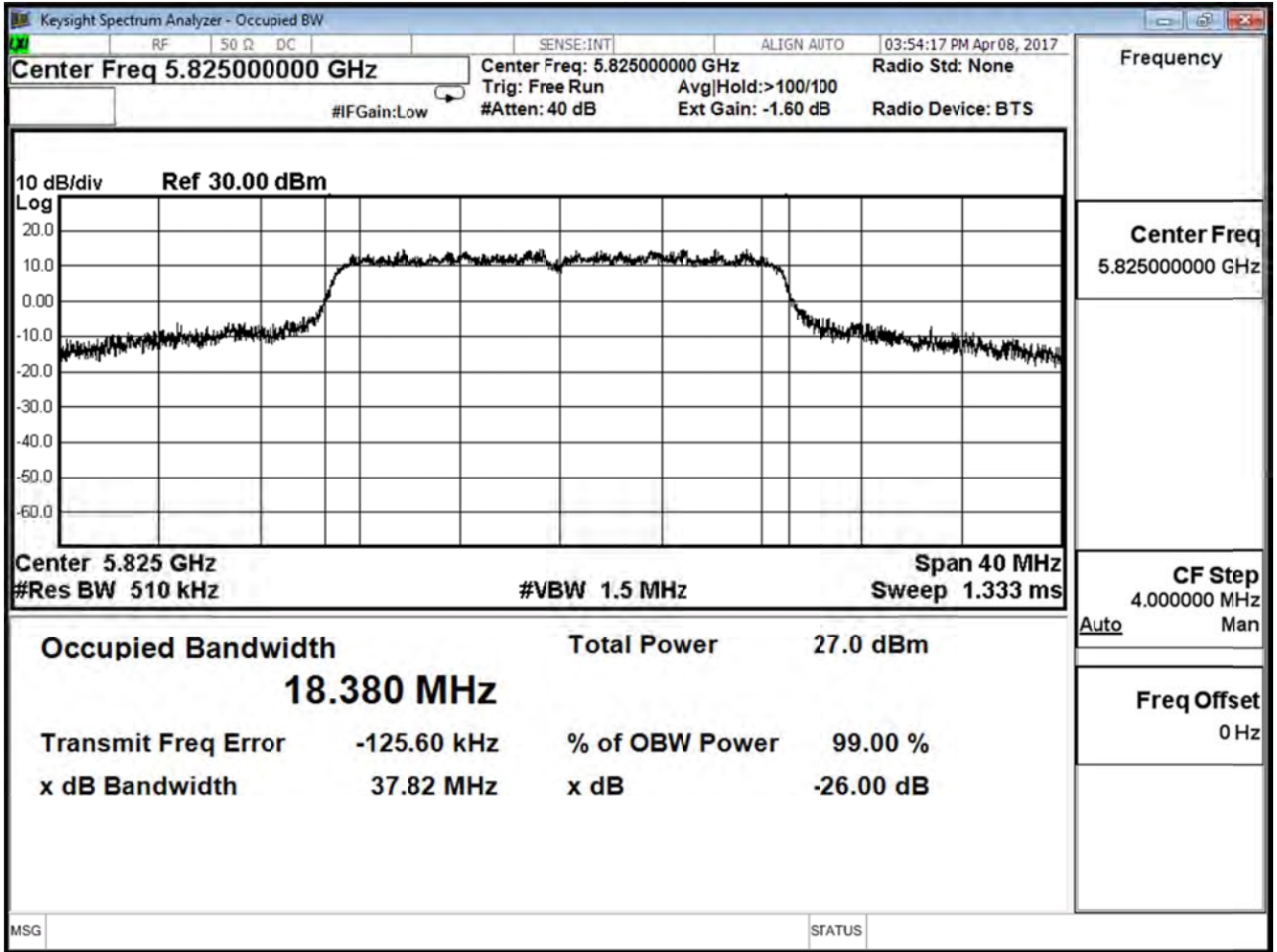

Product	Lyra		
Test Item	99% Bandwidth		
Test Mode	Mode 1: Tx-AD2055320 Mode		
Date of Test	2017/04/08	Test Site	SR10-H

IEEE 802.11n40 (ANT 0)

Channel No.	Frequency (MHz)	Measure Value (MHz)	Limit (MHz)
151	5755	48.272	--
159	5795	55.877	--

Channel 151 (5755MHz)

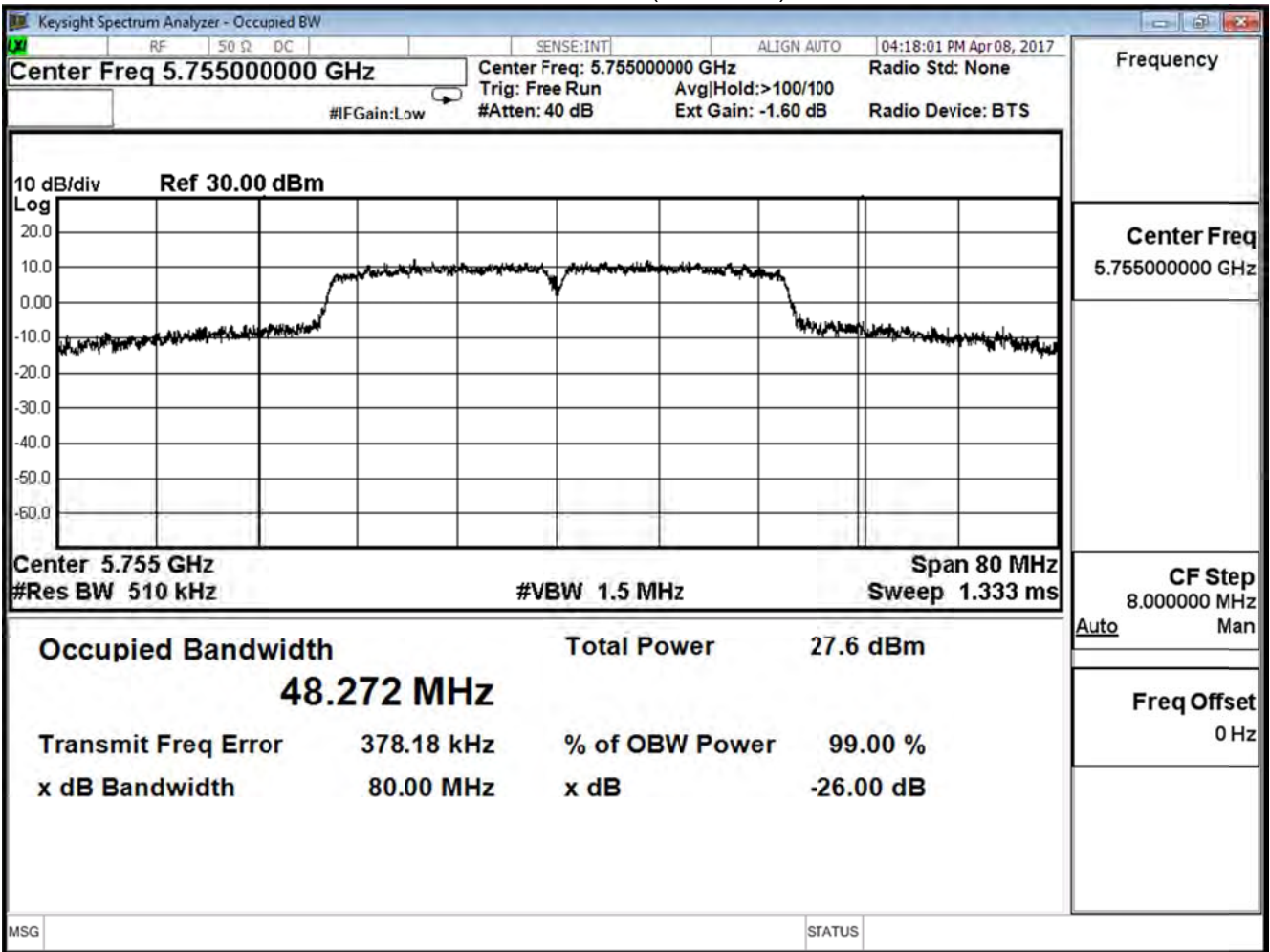

Channel 159 (5795MHz)

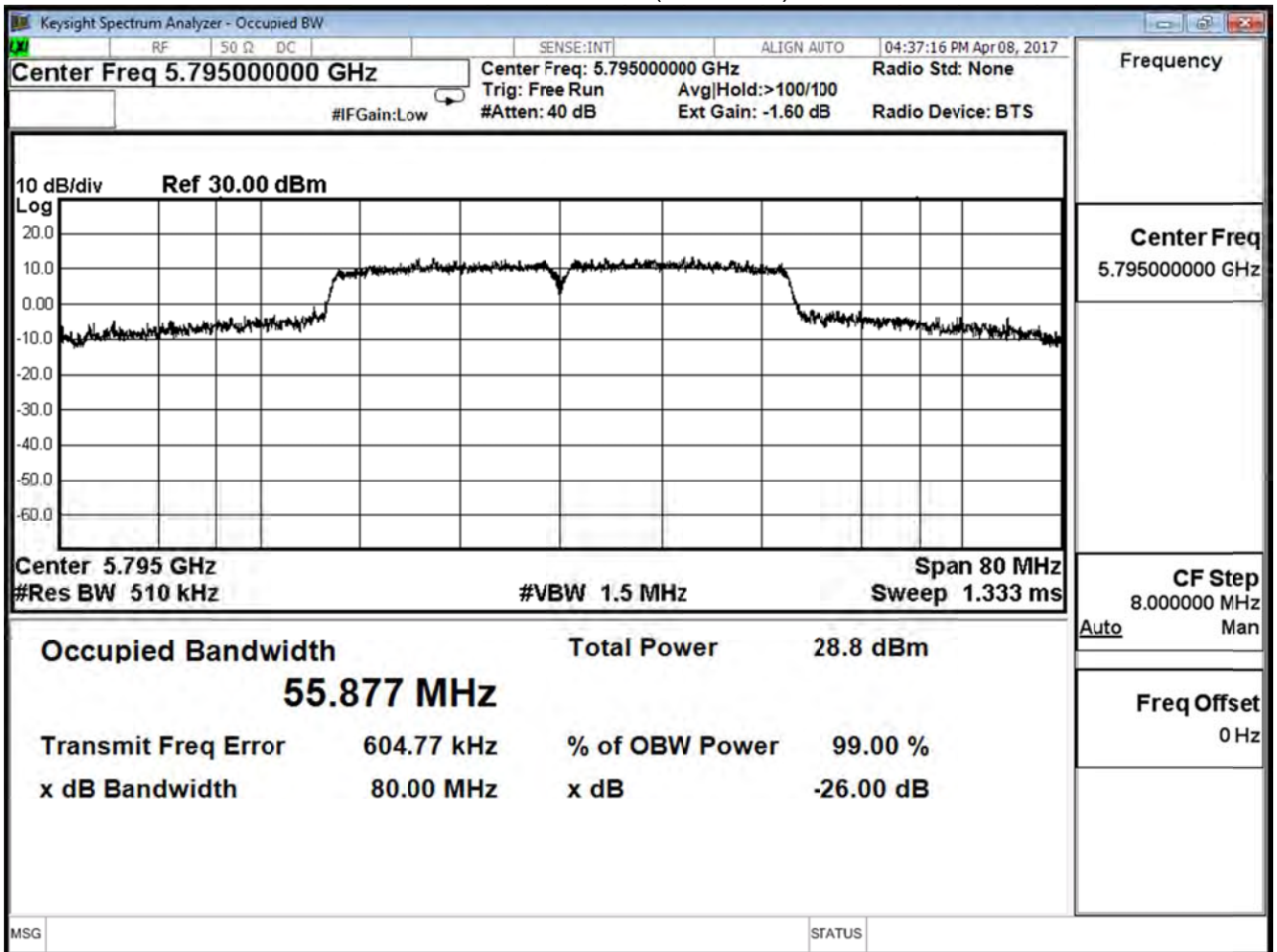

Product	Lyra		
Test Item	99% Bandwidth		
Test Mode	Mode 1: Tx-AD2055320 Mode		
Date of Test	2017/04/08	Test Site	SR10-H

IEEE 802.11n40 (ANT 1)			
Channel No.	Frequency (MHz)	Measure Value (MHz)	Limit (MHz)
151	5755	36.566	--
159	5795	51.361	--

Channel 151 (5755MHz)

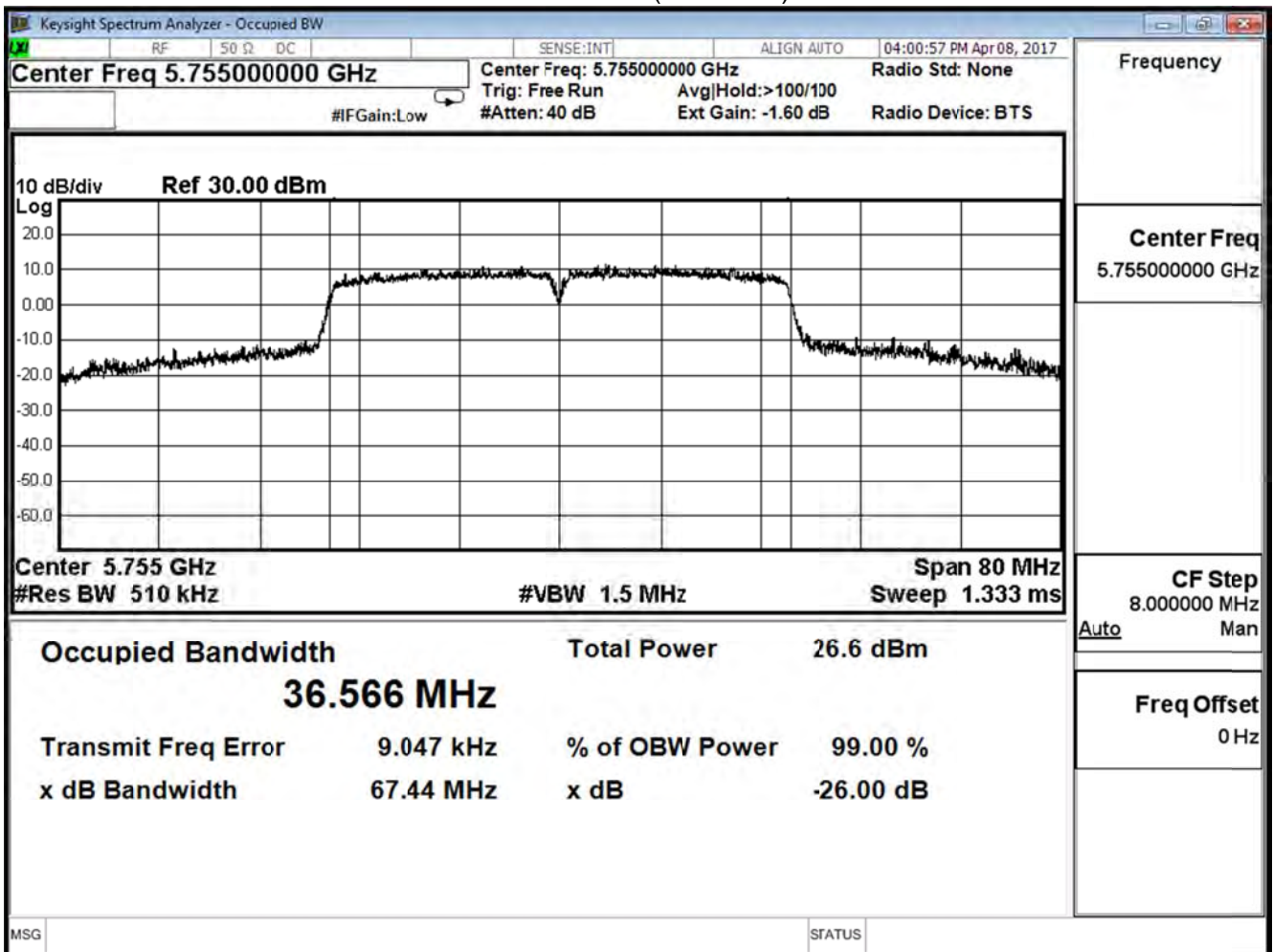

Channel 159 (5795MHz)

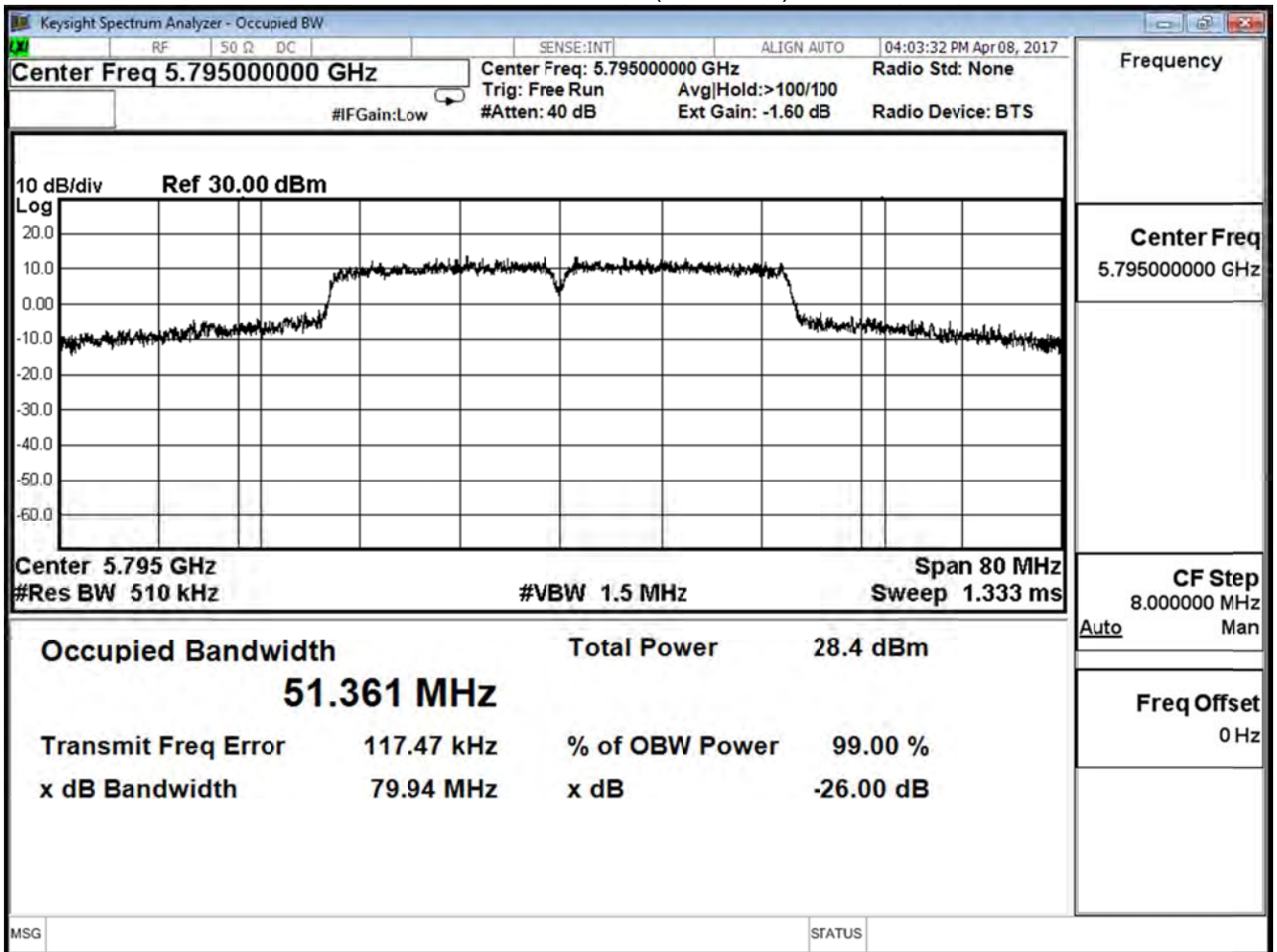

Product	Lyra		
Test Item	99% Bandwidth		
Test Mode	Mode 1: Tx-AD2055320 Mode		
Date of Test	2017/04/08	Test Site	SR10-H

IEEE 802.11ac80 (ANT 0)			
Channel No.	Frequency (MHz)	Measure Value (MHz)	Limit (MHz)
155	5775	76.301	--

Channel 155 (5775MHz)

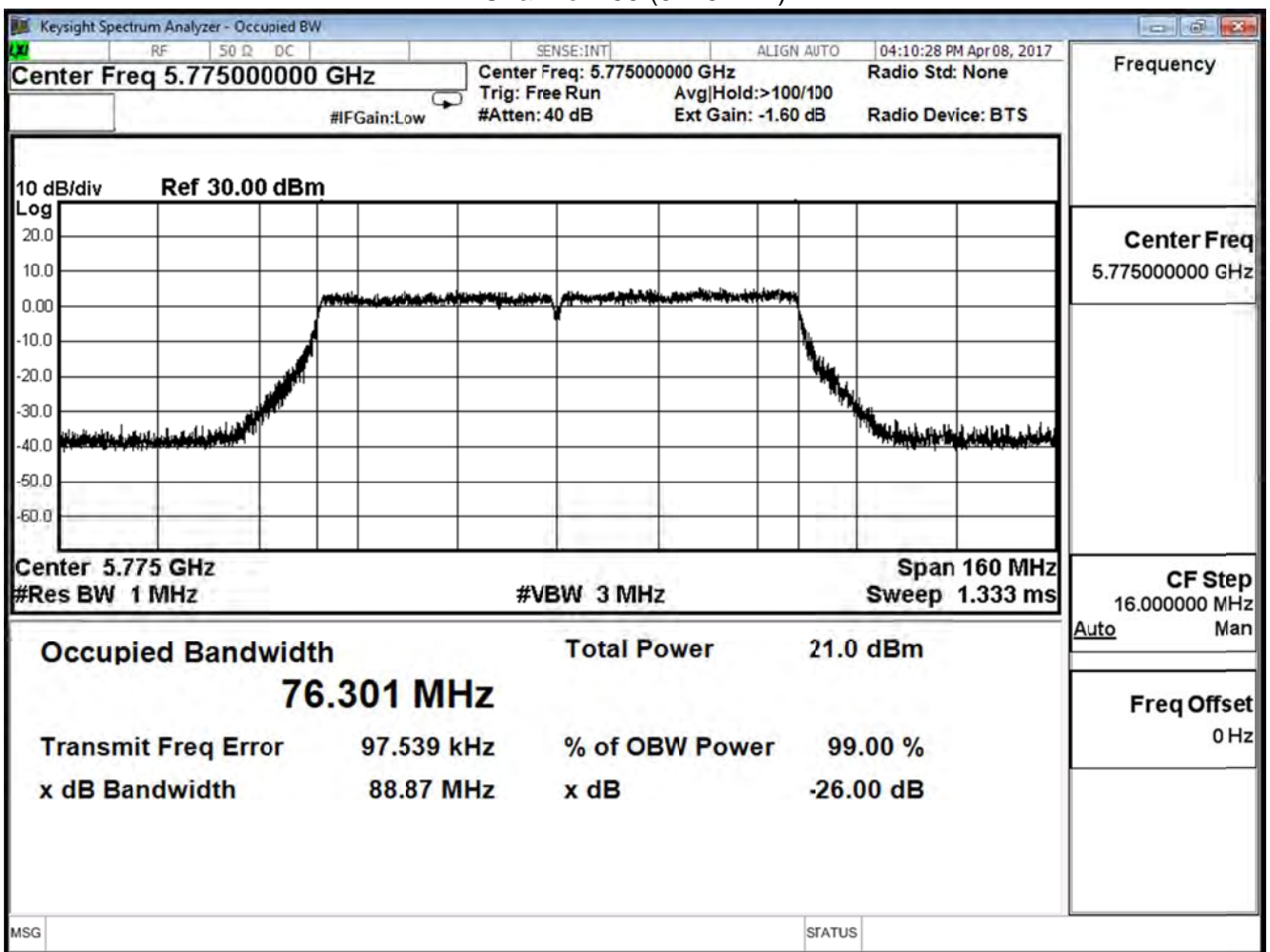

Product	Lyra		
Test Item	99% Bandwidth		
Test Mode	Mode 1: Tx-AD2055320 Mode		
Date of Test	2017/04/08	Test Site	SR10-H

IEEE 802.11ac80 (ANT 1)			
Channel No.	Frequency (MHz)	Measure Value (MHz)	Limit (MHz)
155	5775	76.029	--

Channel 155 (5775MHz)

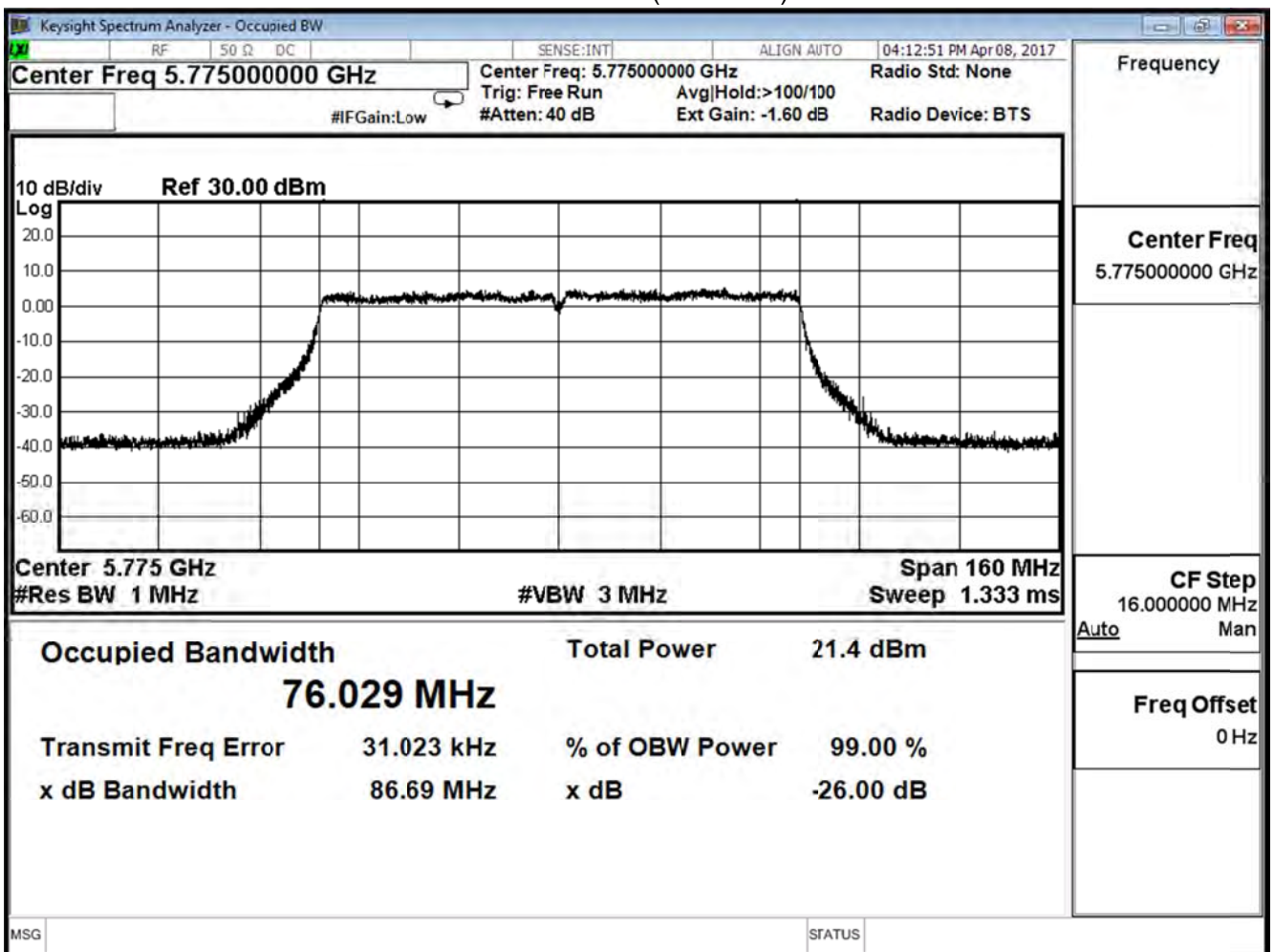

Product	Lyra		
Test Item	DTS Bandwidth		
Test Mode	Mode 1: Tx-AD2055320 Mode		
Date of Test	2017/04/12	Test Site	SR10-H

IEEE 802.11a (ANT 0)				
Channel No.	Frequency (MHz)	Measure Level (MHz)	Limit (MHz)	Result
149	5745	16.30	≥ 0.5	Pass
157	5785	16.32	≥ 0.5	Pass
165	5825	16.32	≥ 0.5	Pass

Channel 149 (5745MHz)

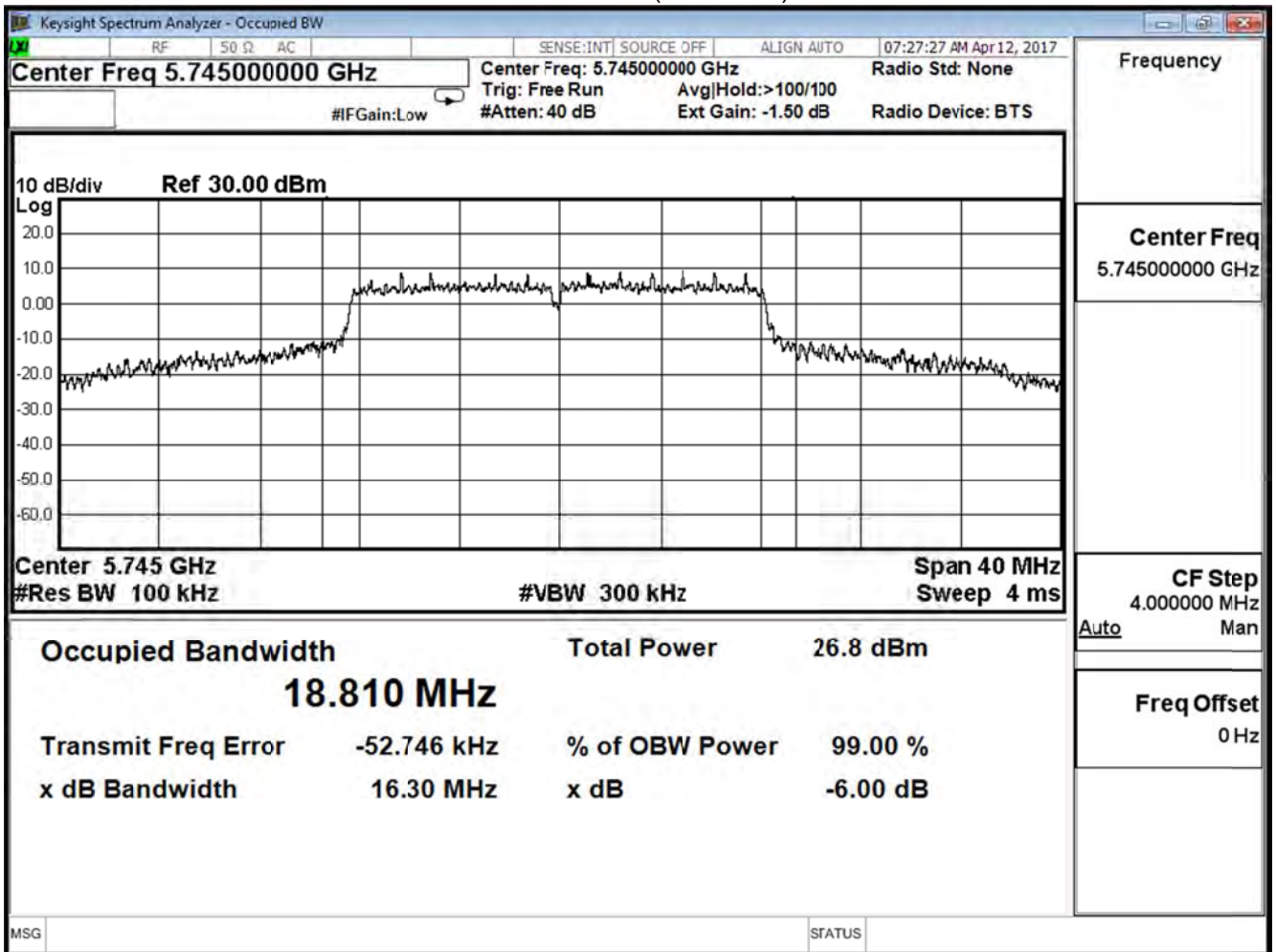

Channel 157 (5785MHz)

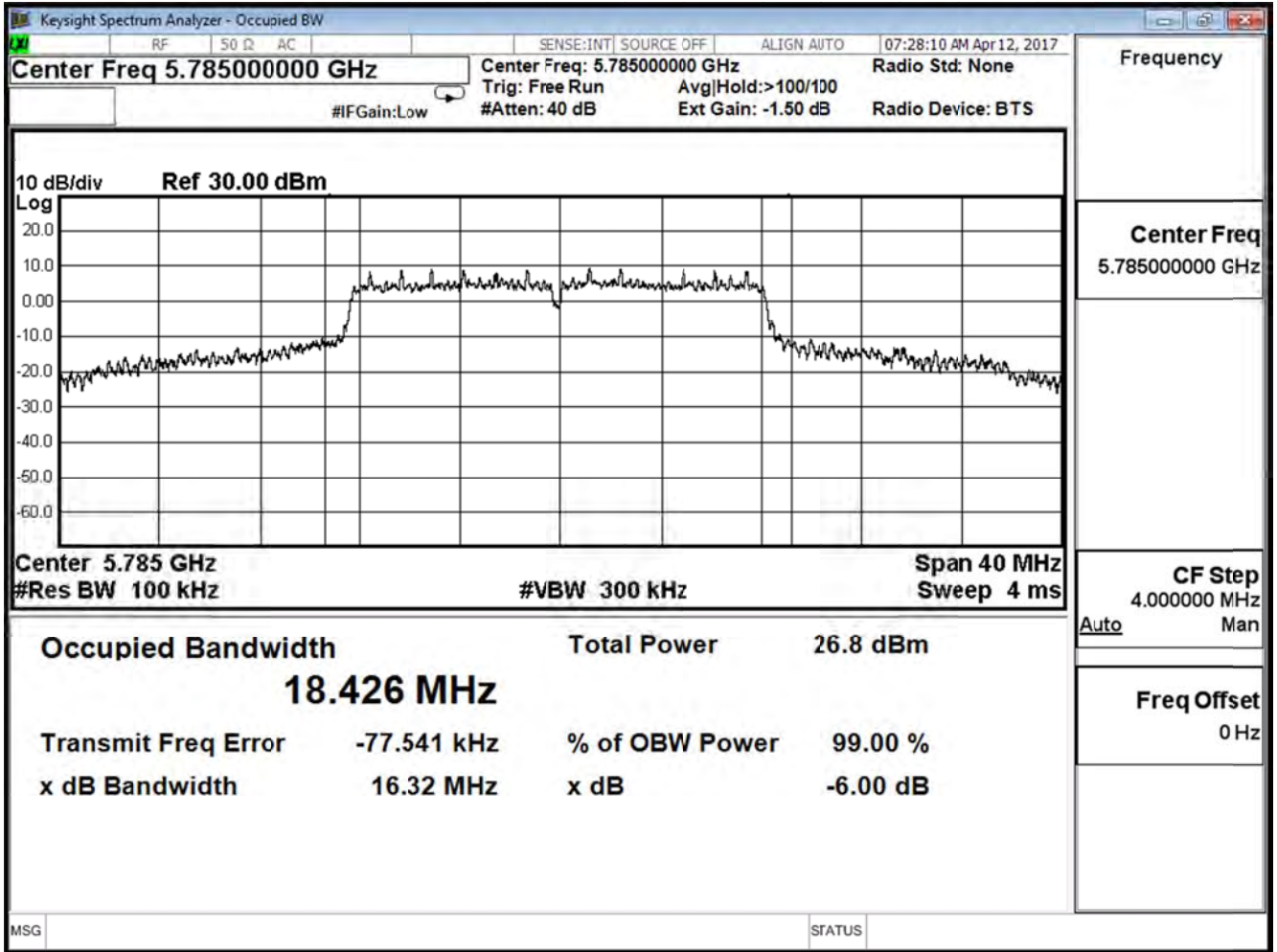

Channel 165 (5825MHz)

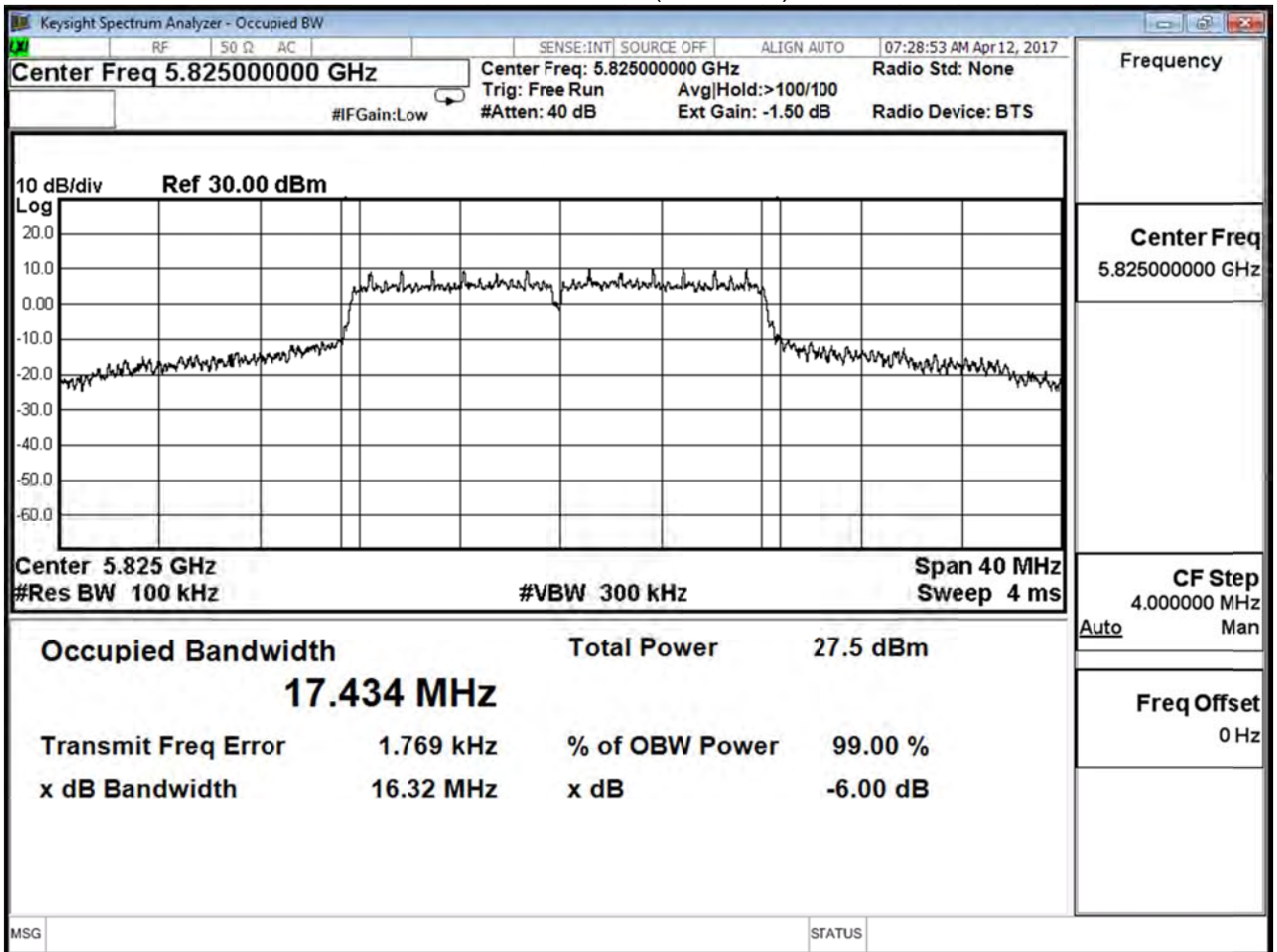

Product	Lyra		
Test Item	DTS Bandwidth		
Test Mode	Mode 1: Tx-AD2055320 Mode		
Date of Test	2017/04/12	Test Site	SR10-H

IEEE 802.11a (ANT 1)				
Channel No.	Frequency (MHz)	Measure Level (MHz)	Limit (MHz)	Result
149	5745	16.33	≥ 0.5	Pass
157	5785	16.33	≥ 0.5	Pass
165	5825	16.30	≥ 0.5	Pass

Channel 149 (5745MHz)

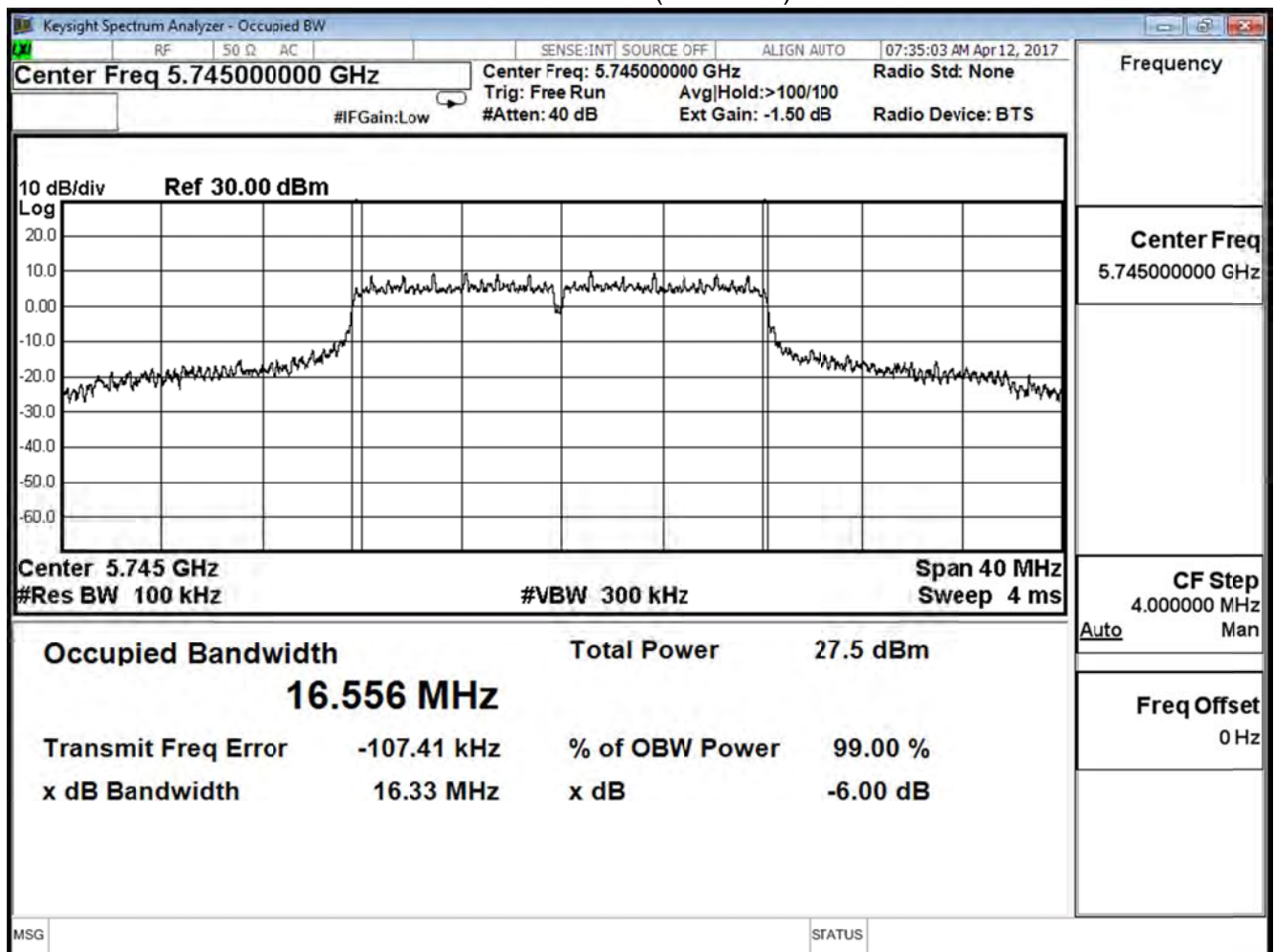

Channel 157 (5785MHz)

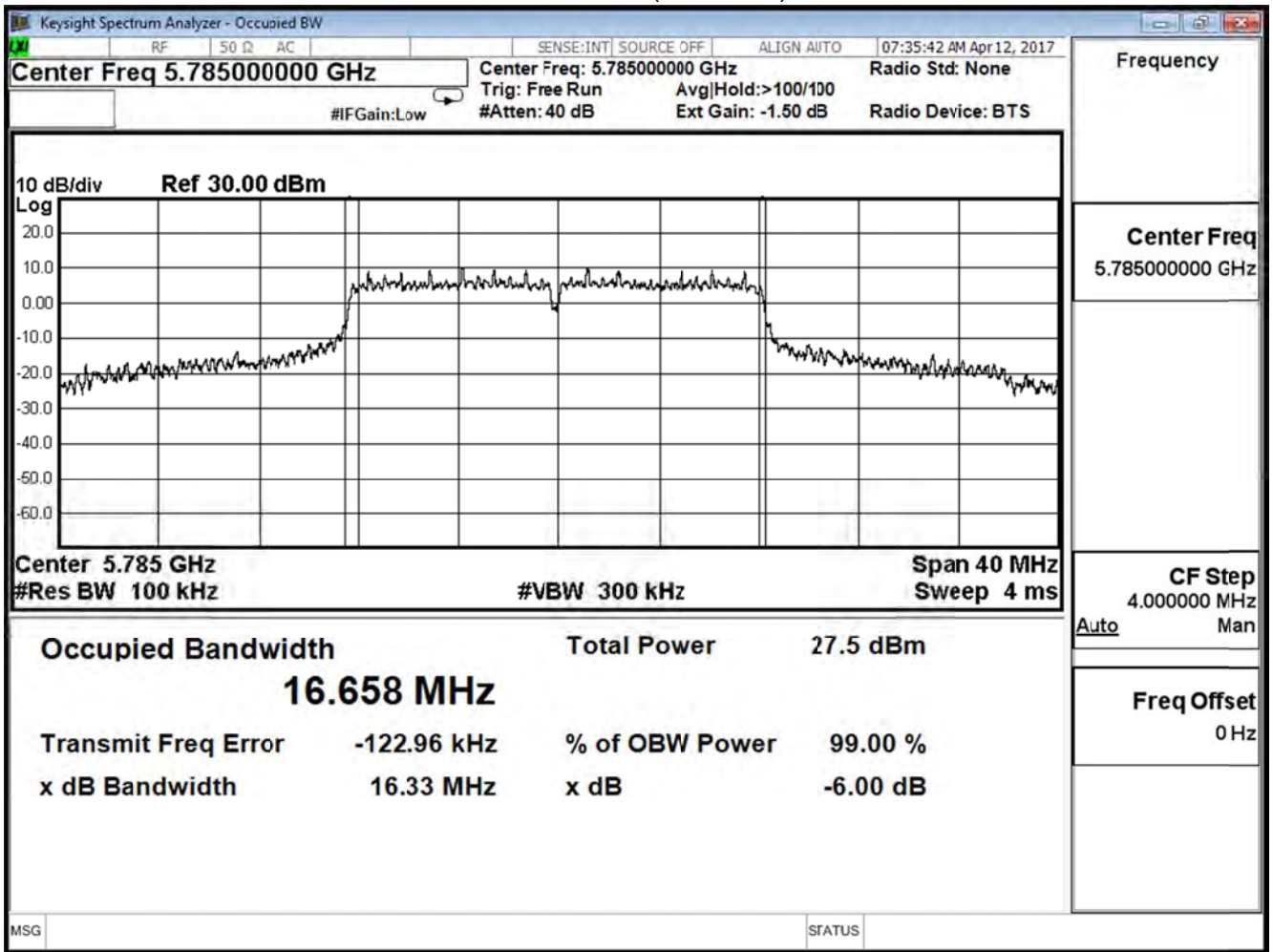

Channel 165 (5825MHz)

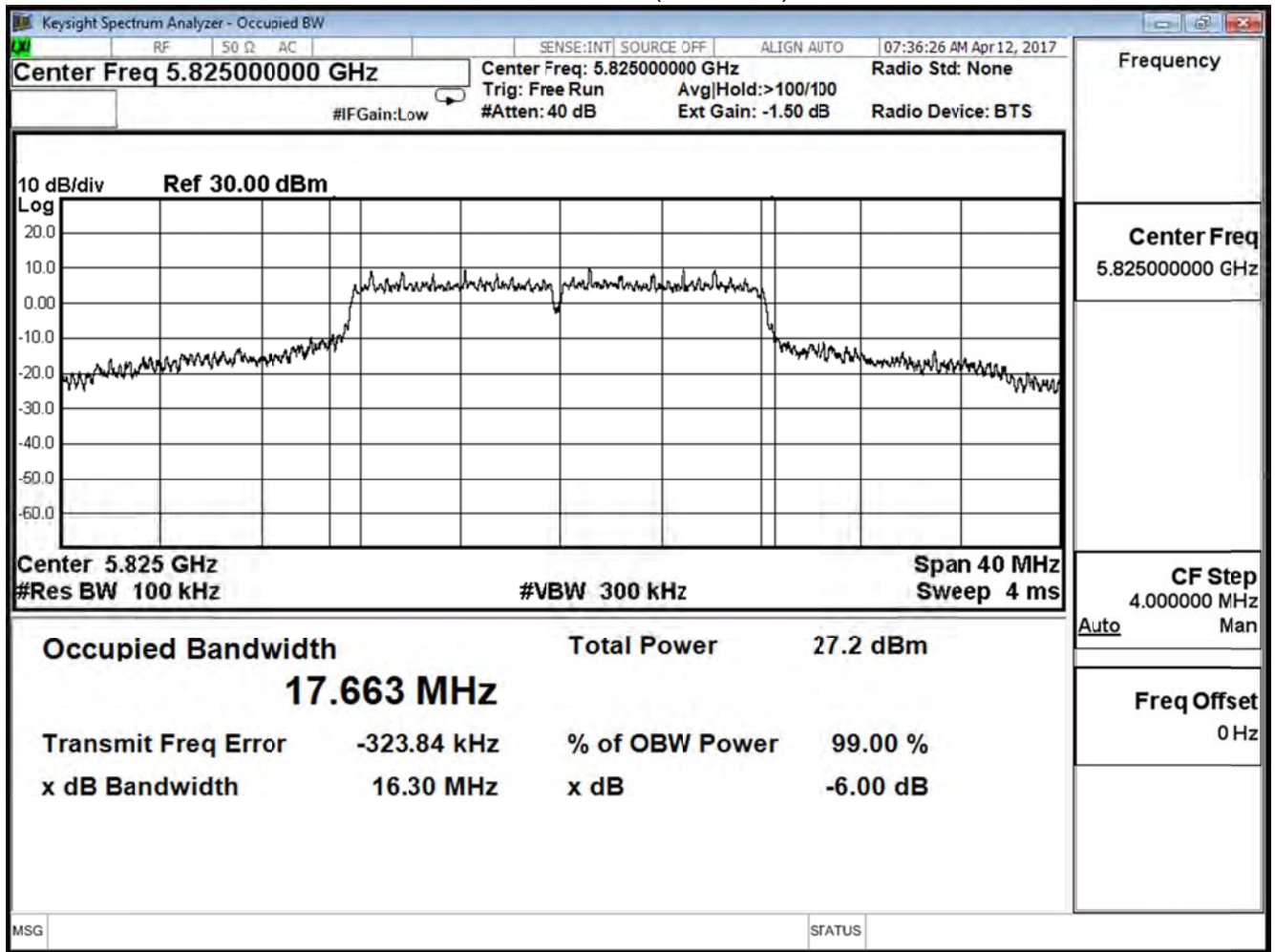

Product	Lyra		
Test Item	DTS Bandwidth		
Test Mode	Mode 1: Tx-AD2055320 Mode		
Date of Test	2017/04/12	Test Site	SR10-H

IEEE 802.11n20 (ANT 0)

Channel No.	Frequency (MHz)	Measure Level (MHz)	Limit (MHz)	Result
149	5745	17.31	≥ 0.5	Pass
157	5785	17.30	≥ 0.5	Pass
165	5825	17.55	≥ 0.5	Pass

Channel 149 (5745MHz)

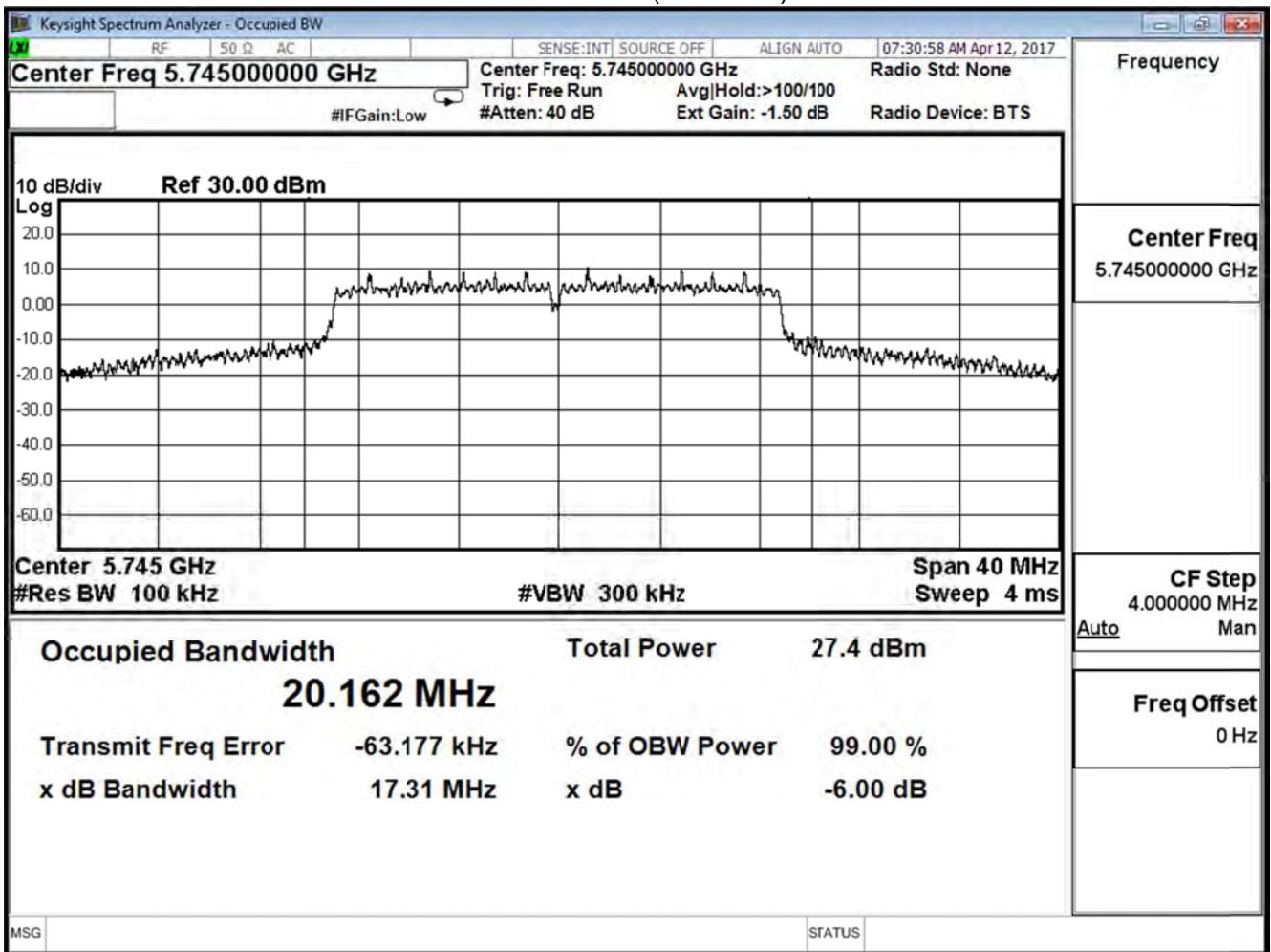

Channel 157 (5785MHz)

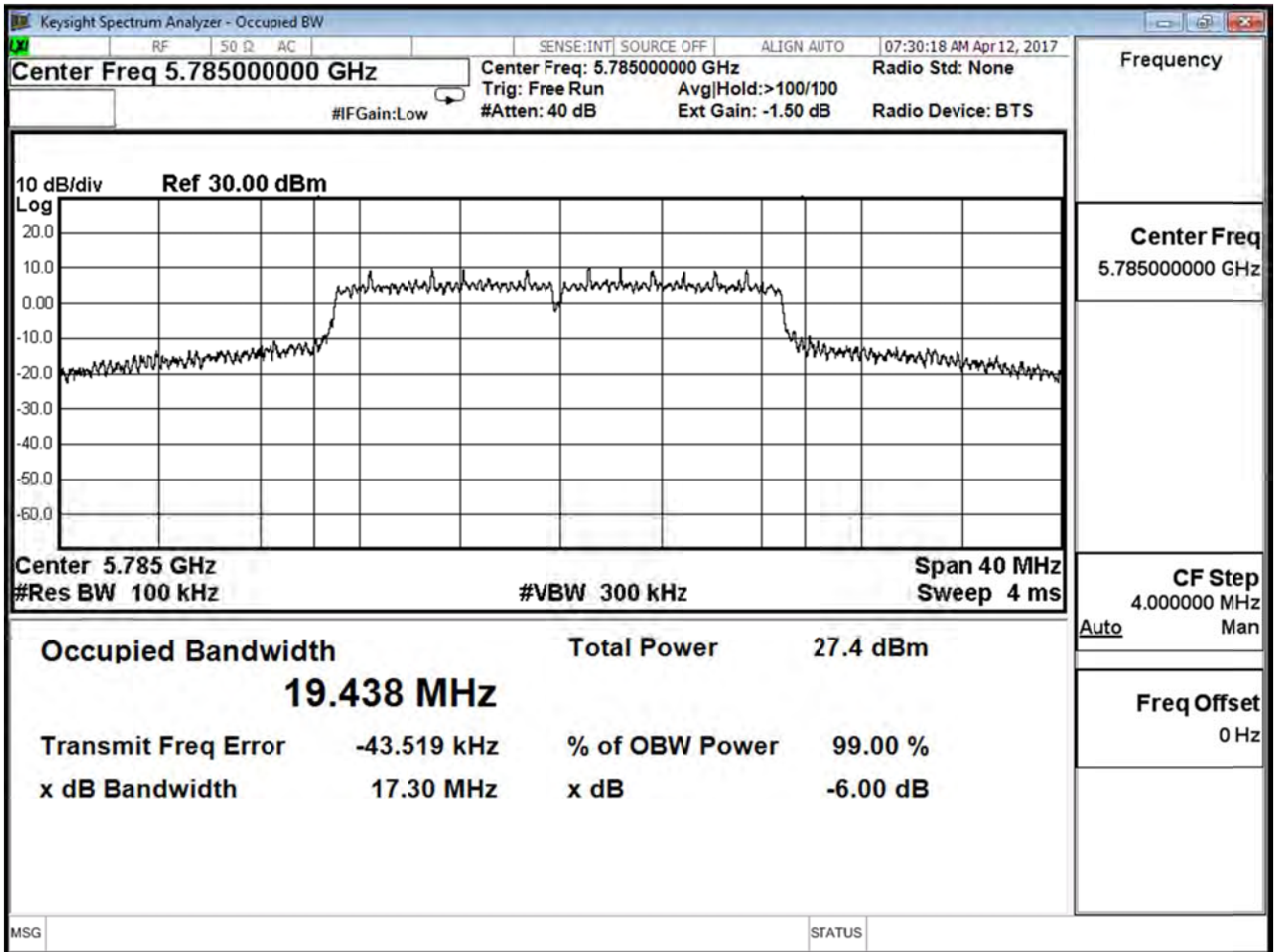

Channel 165 (5825MHz)

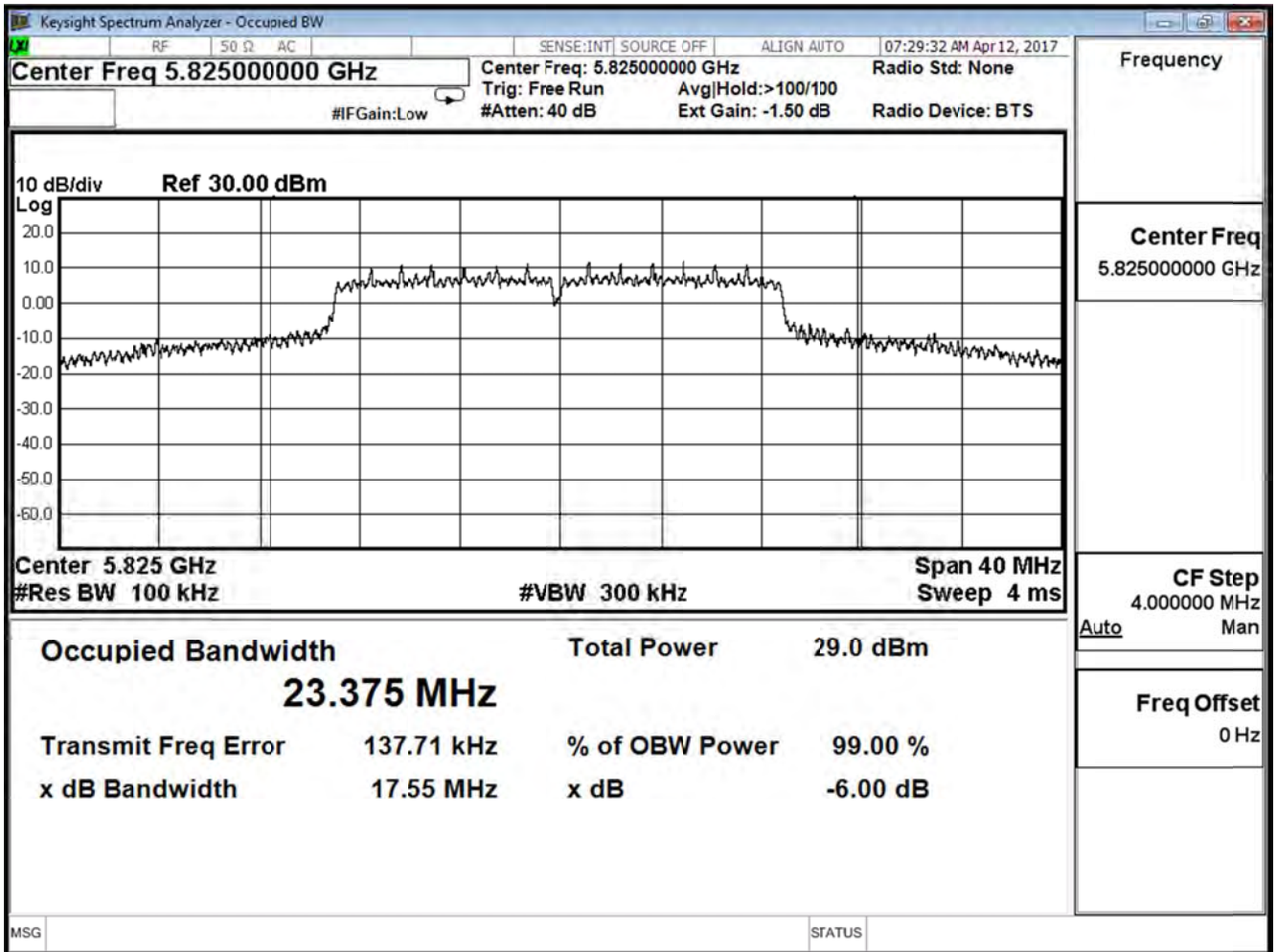

Product	Lyra		
Test Item	DTS Bandwidth		
Test Mode	Mode 1: Tx-AD2055320 Mode		
Date of Test	2017/04/12	Test Site	SR10-H

IEEE 802.11n20 (ANT 1)

Channel No.	Frequency (MHz)	Measure Level (MHz)	Limit (MHz)	Result
149	5745	17.52	≥ 0.5	Pass
157	5785	16.96	≥ 0.5	Pass
165	5825	17.21	≥ 0.5	Pass

Channel 149 (5745MHz)

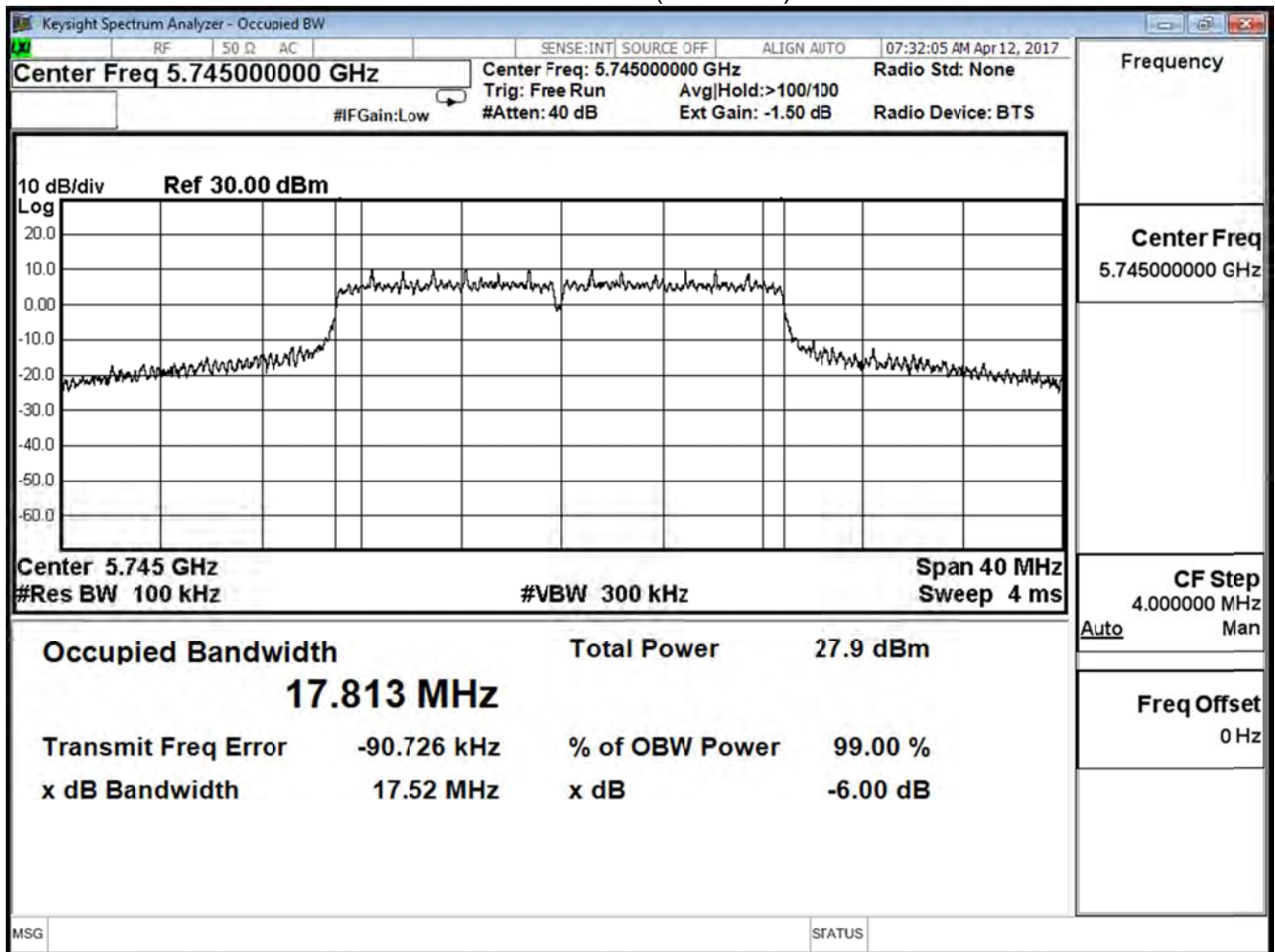

Channel 157 (5785MHz)

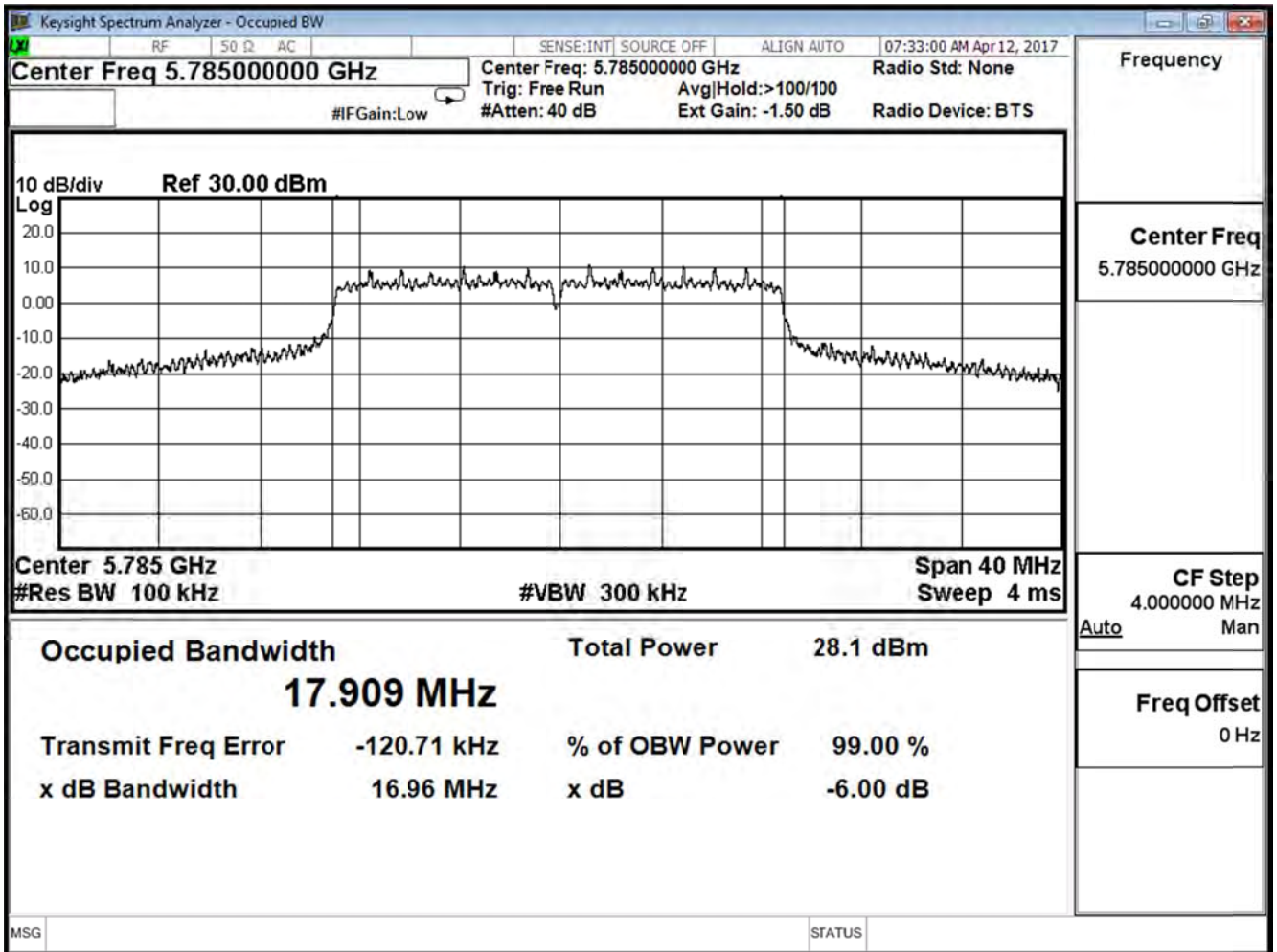

Channel 165 (5825MHz)

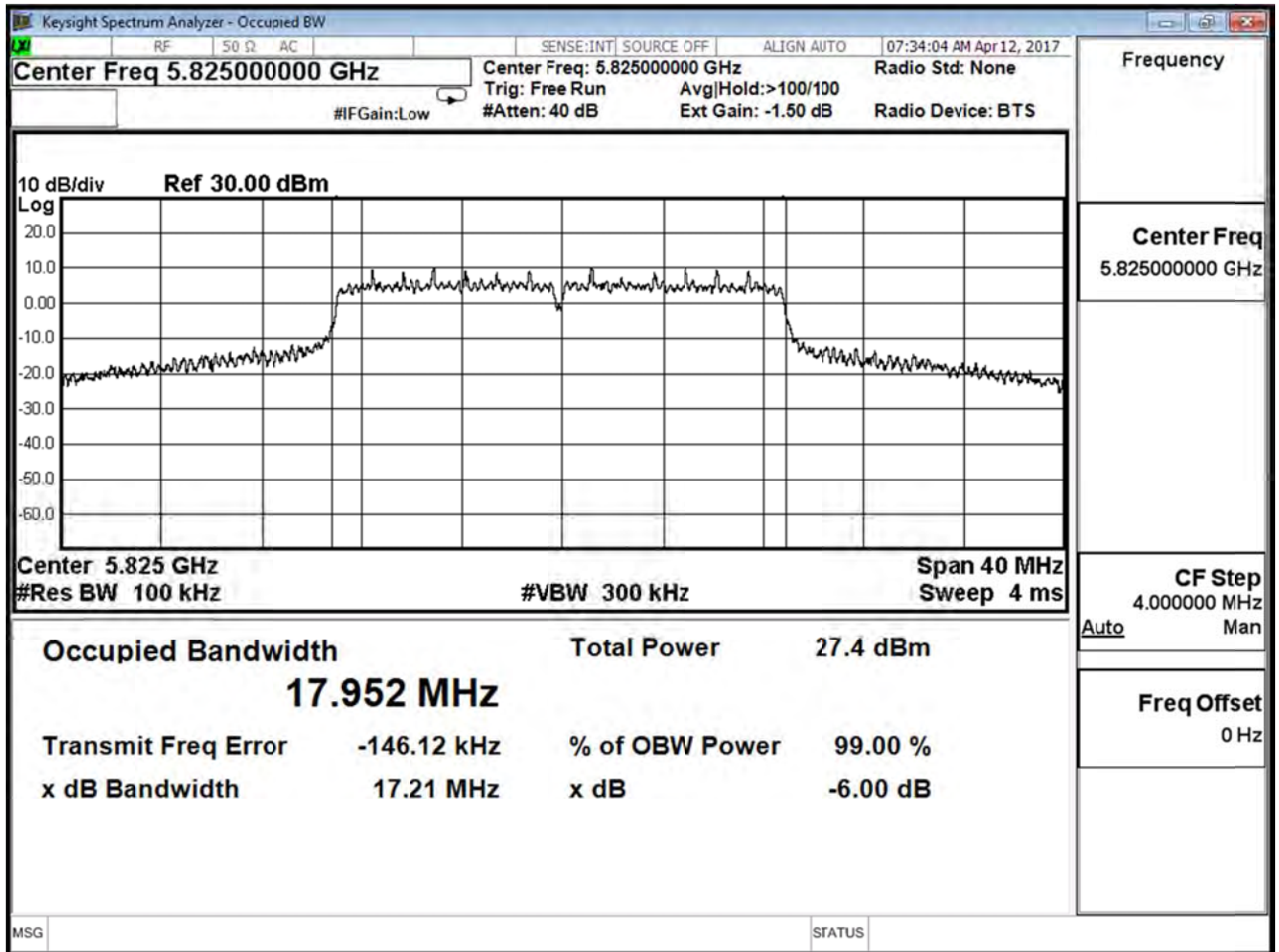

Product	Lyra		
Test Item	DTS Bandwidth		
Test Mode	Mode 1: Tx-AD2055320 Mode		
Date of Test	2017/04/12	Test Site	SR10-H

IEEE 802.11n40 (ANT 0)				
Channel No.	Frequency (MHz)	Measure Level (MHz)	Limit (MHz)	Result
151	5755	35.11	≥ 0.5	Pass
159	5795	35.11	≥ 0.5	Pass

Channel 151 (5755MHz)

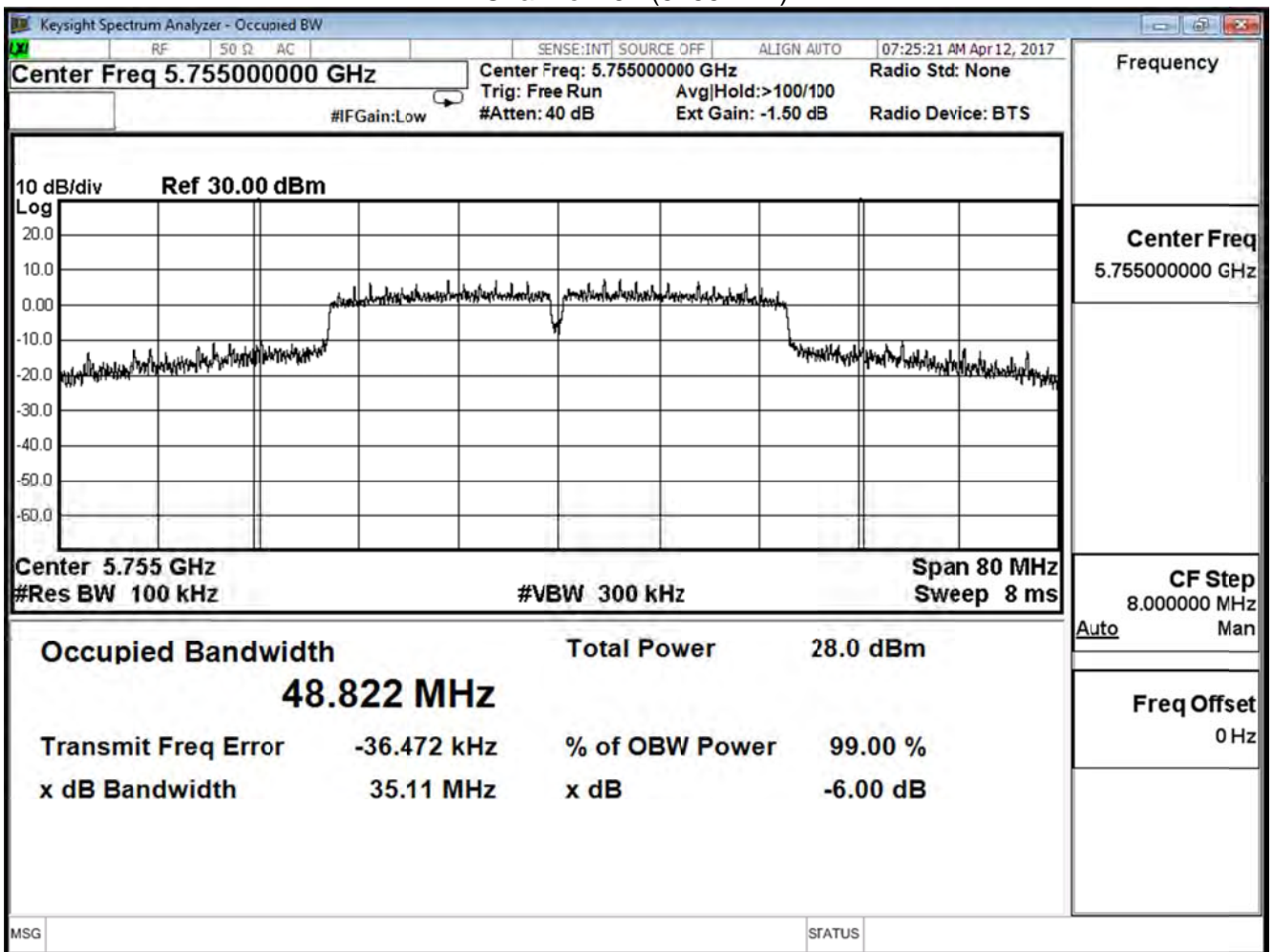

Channel 159 (5795MHz)

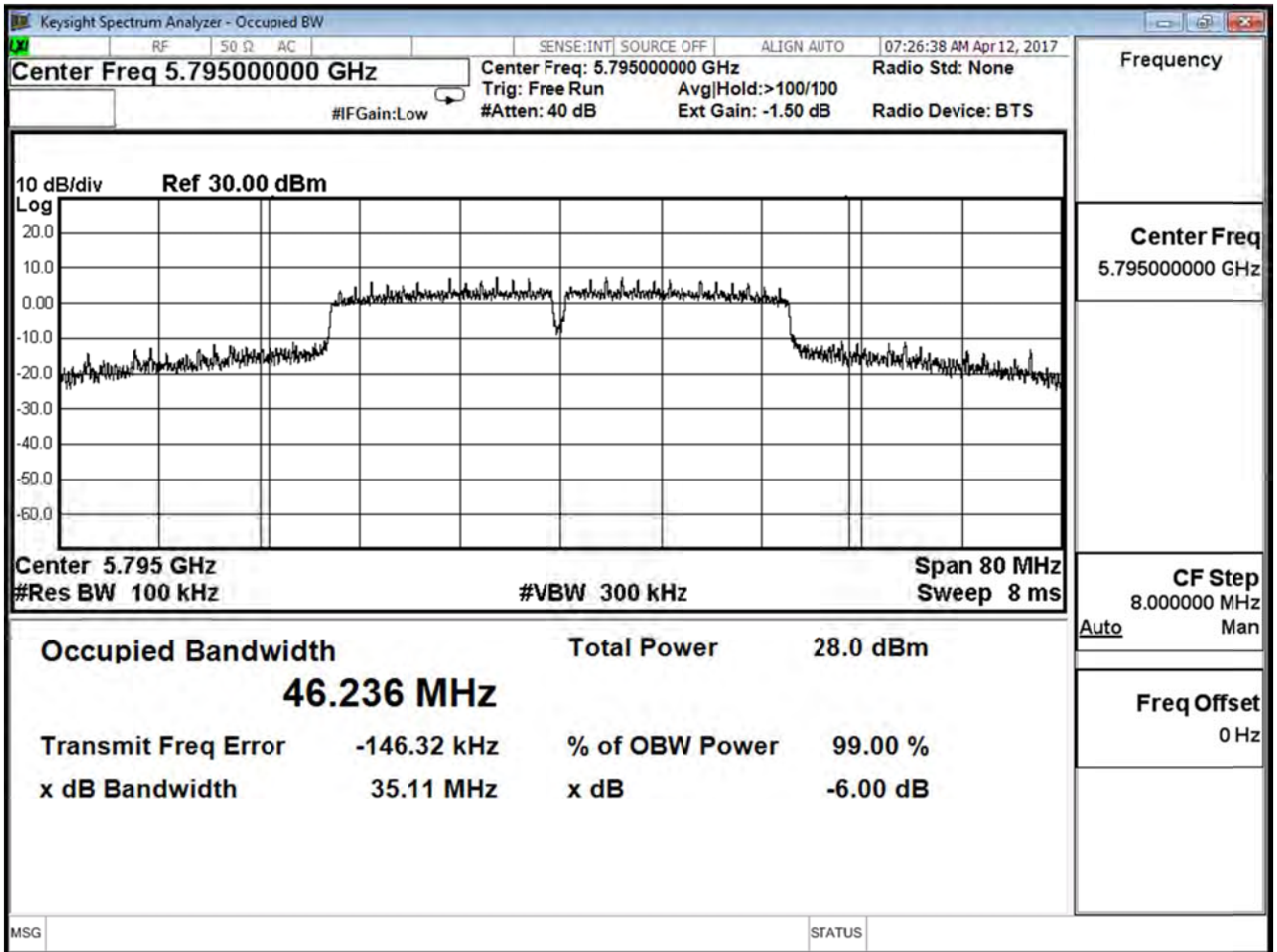

Product	Lyra		
Test Item	DTS Bandwidth		
Test Mode	Mode 1: Tx-AD2055320 Mode		
Date of Test	2017/04/12	Test Site	SR10-H

IEEE 802.11n40 (ANT 1)				
Channel No.	Frequency (MHz)	Measure Level (MHz)	Limit (MHz)	Result
151	5755	35.12	≥ 0.5	Pass
159	5795	35.15	≥ 0.5	Pass

Channel 151 (5755MHz)

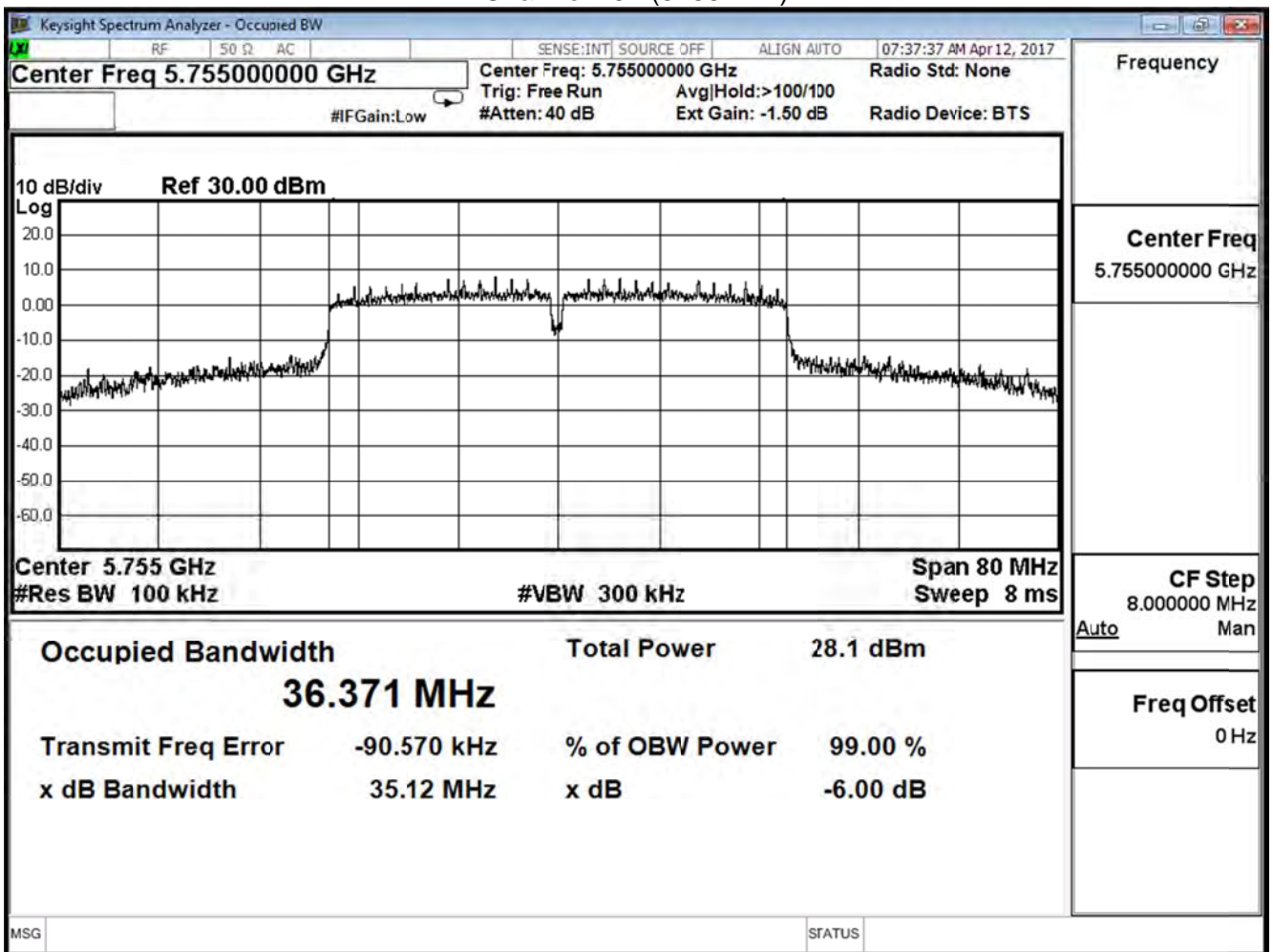

Channel 159 (5795MHz)

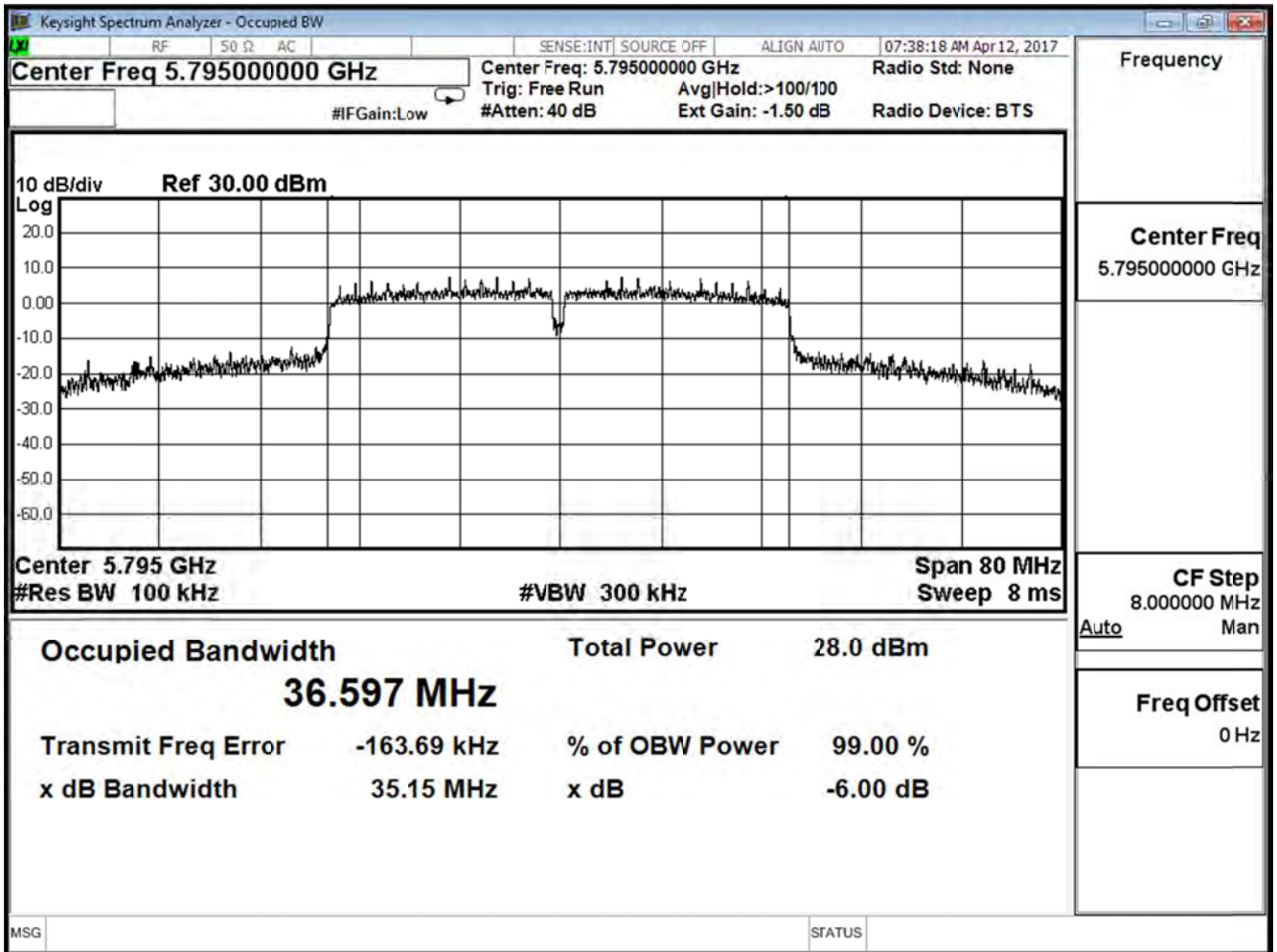

Product	Lyra		
Test Item	DTS Bandwidth		
Test Mode	Mode 1: Tx-AD2055320 Mode		
Date of Test	2017/04/12	Test Site	SR10-H

IEEE 802.11ac80 (ANT 0)				
Channel No.	Frequency (MHz)	Measure Level (MHz)	Limit (MHz)	Result
155	5775	76.28	≥ 0.5	Pass

Channel 155 (5775MHz)

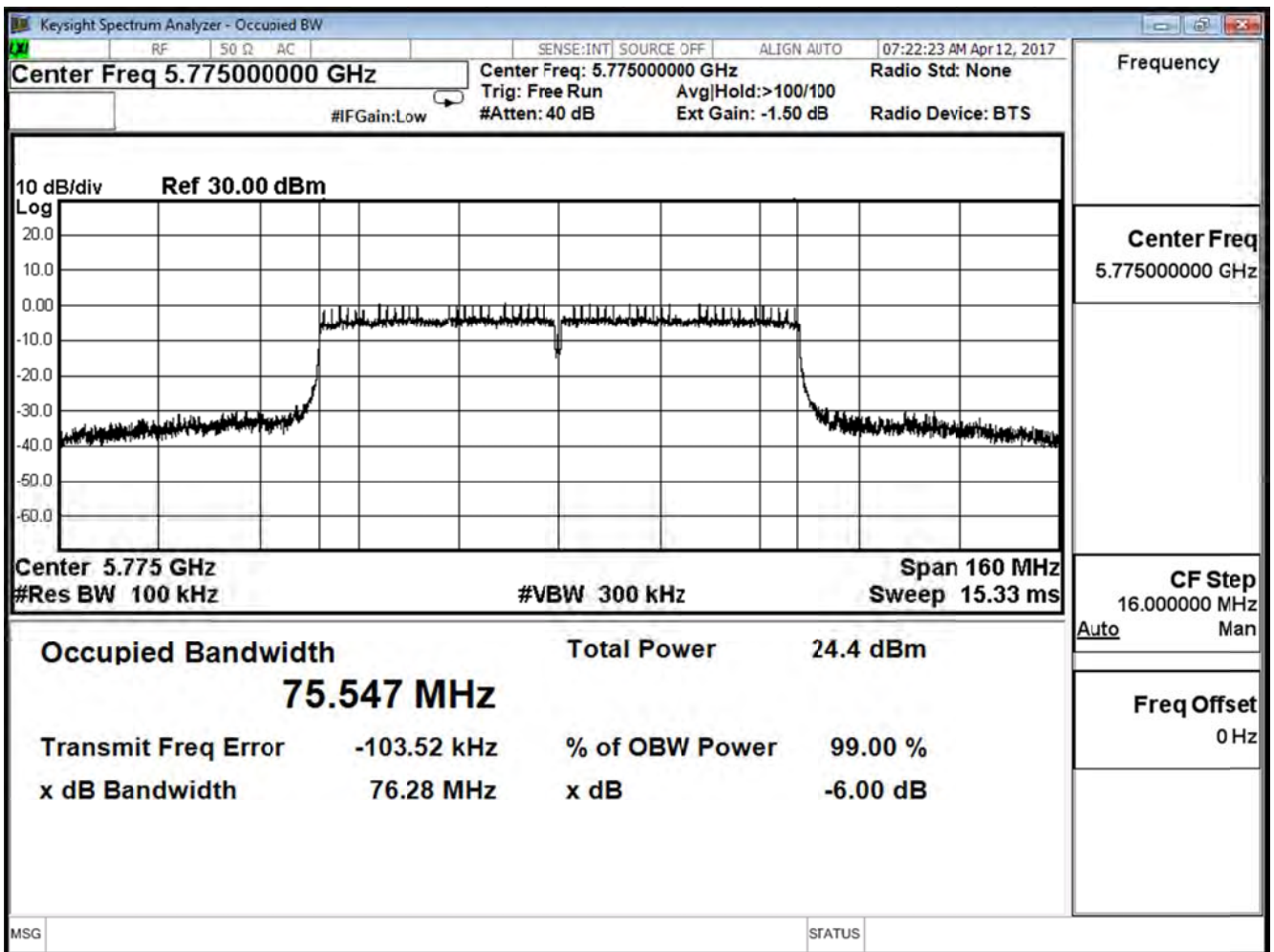

Product	Lyra		
Test Item	DTS Bandwidth		
Test Mode	Mode 1: Tx-AD2055320 Mode		
Date of Test	2017/04/12	Test Site	SR10-H

IEEE 802.11ac80 (ANT 1)				
Channel No.	Frequency (MHz)	Measure Level (MHz)	Limit (MHz)	Result
155	5775	75.49	≥ 0.5	Pass

Channel 155 (5775MHz)

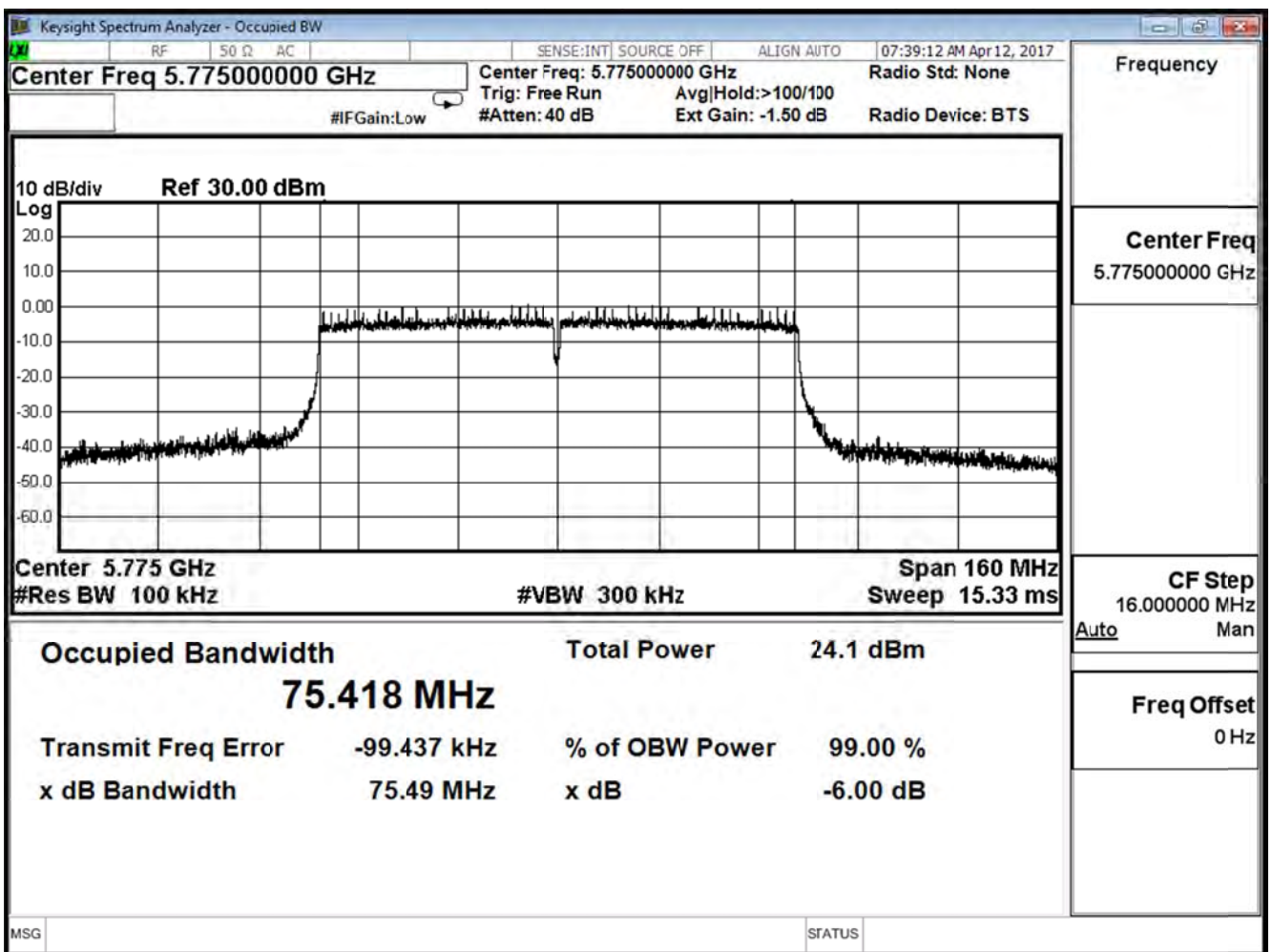

4. Peak Transmit power

4.1. Test Equipment

The following test equipments are used during the radiated emission tests:

Peak Transmit Output / SR10-H

Instrument	Manufacturer	Model No.	Serial No	Next Cal. Date
EXA Signal Analyzer	Keysight	N9010A	MY51440132	2018/03/12

Note: All equipments that need to calibrate are with calibration period of 1 year.

4.2. Test Setup

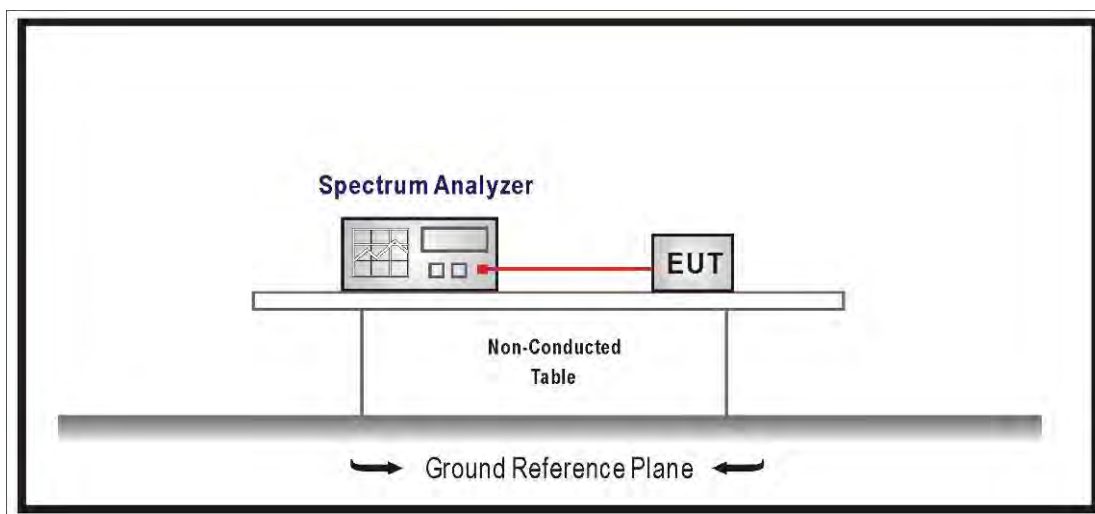

4.3. Limits

1. For the band 5.15-5.25 GHz, the peak transmit power over the frequency band of operation shall not exceed the lesser of 1W. If transmitting antenna of directional gain greater than 6 dBi are used, the peak transmit power shall be reduced by the amount in dB that directional gain of the antenna exceeds 6 dBi.
2. For client devices in the 5.15-5.25 GHz band, the maximum conducted output power over the frequency band of operation shall not exceed 250 mW provided the maximum antenna gain does not exceed 6 dBi. The maximum conducted output power and the maximum power spectral density shall be reduced by the amount in dB that the directional gain of the antenna exceeds 6 dBi.
3. For the band 5.25-5.35 GHz, the peak transmit power over the frequency band of operation shall not exceed the lesser of 250 mW. If transmitting antenna of directional gain greater than 6 dBi are used, the peak transmit power shall be reduced by the amount in dB that directional gain of the antenna exceeds 6 dBi.
4. For the band 5.725-5.850 GHz, the peak transmit power over the frequency band of operation shall not exceed the lesser of 1W. If transmitting antenna of directional gain greater than 6 dBi are used, the peak transmit power shall be reduced by the amount in dB that directional gain of the antenna exceeds 6 dBi.

4.4. Test Procedure

The EUT was setup to ANSI C63.10: 2013; tested to U-NII test procedure of 789033 D02 V01r03 and 662911 D01 v02r01 for compliance to FCC 47CFR Subpart E requirements.

The Method SA-1 of the Maximum conducted output power was used.

Set RBW=1MHz, VBW=3MHz with RMS detector and trace average 100 traces in power averaging mode. Set span to encompass the entire emission bandwidth (EBW) of the signal.

4.5. Uncertainty

The measurement uncertainty is defined as ± 1.27 dB

4.6. Test Result

Product	Lyra		
Test Item	Peak Transmit Output		
Test Mode	Mode 1: Tx-AD2055320 Mode		
Date of Test	2017/04/08	Test Site	SR10-H

IEEE 802.11a (ANT 0)			
Channel No.	Frequency (MHz)	Measure Level (dBm)	Limit (dBm)
36	5180	15.990	≤ 30
44	5220	16.710	≤ 30
48	5240	15.020	≤ 30

The worst emission of data rate is 6 Mbps.

Peak Power Output (dBm)									
Channel No	Frequency (MHz)	Data Rate							Required Limit
		6	12	18	24	36	48	54	
36	5180	15.990	--	--	--	--	--	--	≤ 30
44	5220	16.710	16.560	16.420	16.280	16.130	16.000	15.860	≤ 30
48	5240	15.020	--	--	--	--	--	--	≤ 30

Channel 36 (5180MHz)

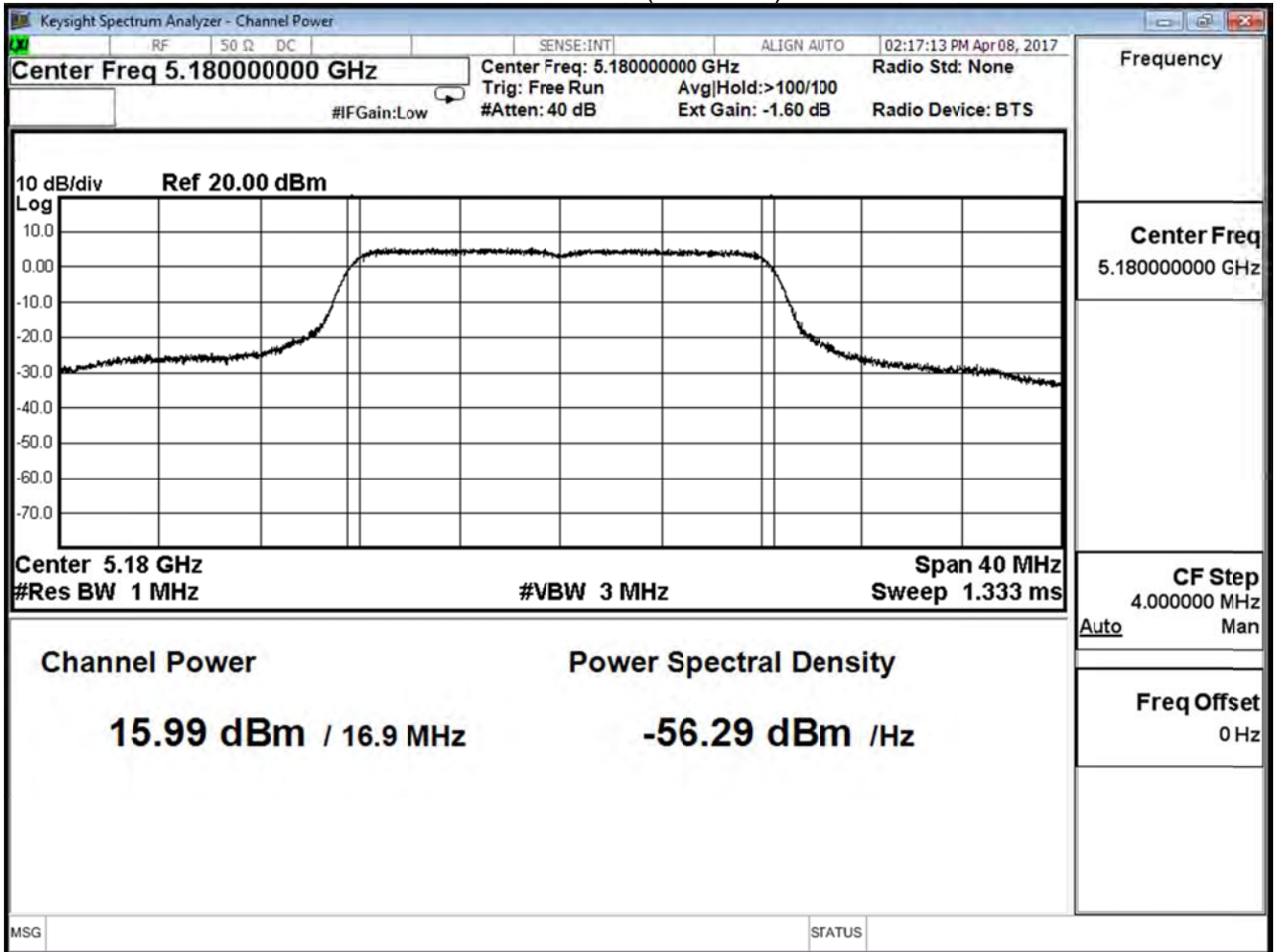

Channel 44 (5220MHz)

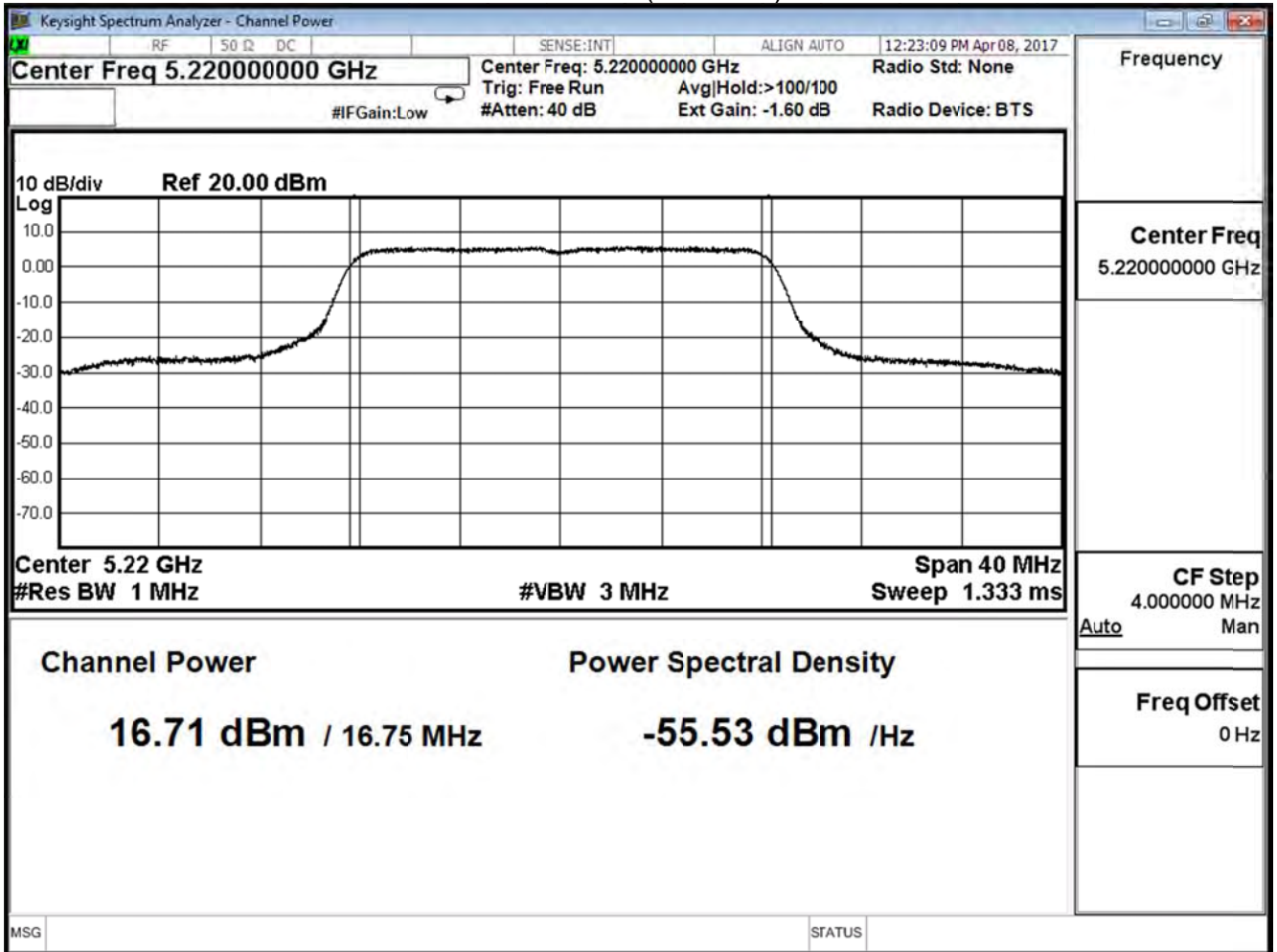

Channel 48 (5240MHz)

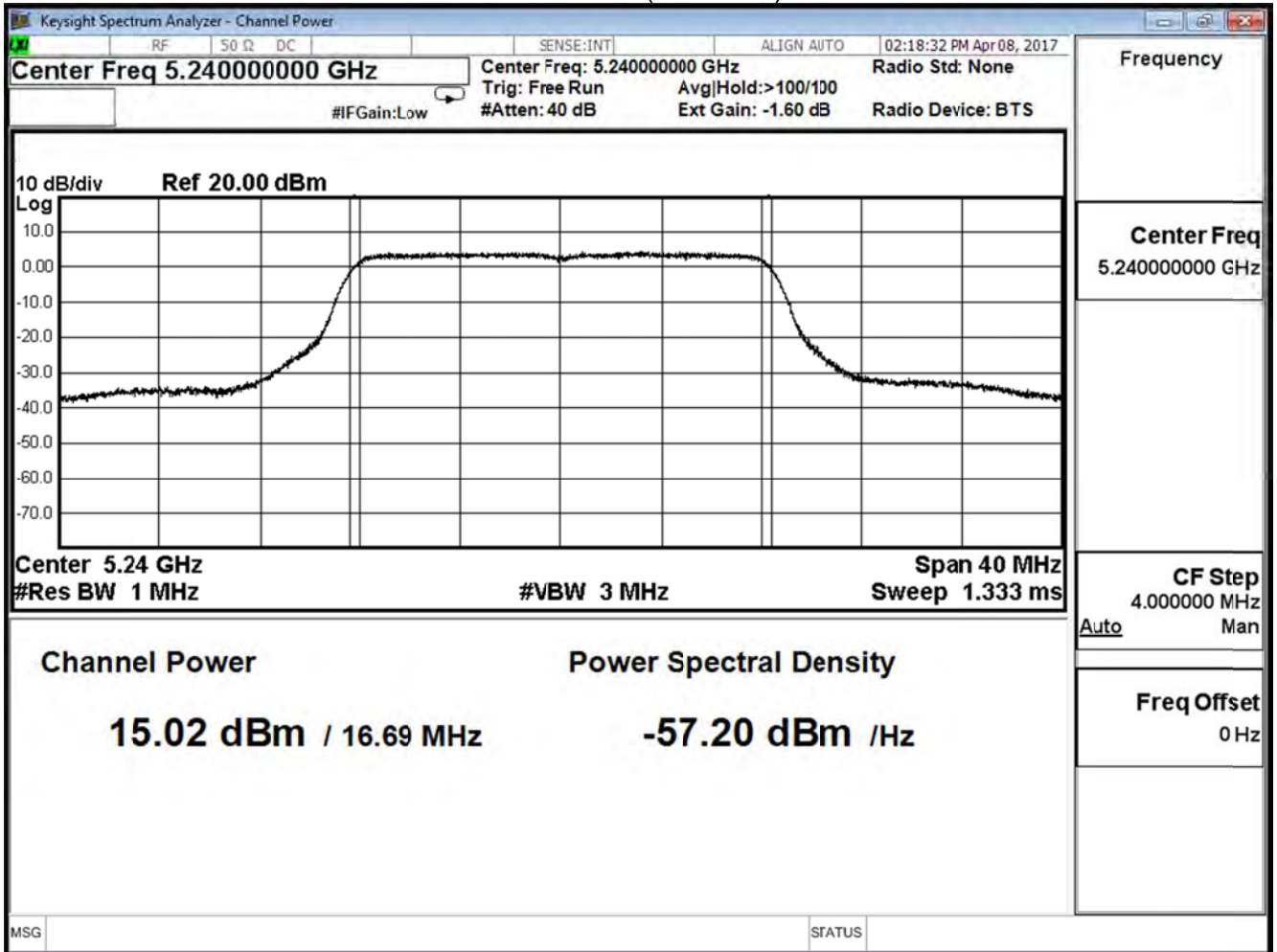

Product	Lyra		
Test Item	Peak Transmit Output		
Test Mode	Mode 1: Tx-AD2055320 Mode		
Date of Test	2017/04/08	Test Site	SR10-H

IEEE 802.11a (ANT 1)			
Channel No.	Frequency (MHz)	Measure Level (dBm)	Limit (dBm)
36	5180	16.280	≤ 30
44	5220	16.900	≤ 30
48	5240	15.240	≤ 30

The worst emission of data rate is 6 Mbps.

Peak Power Output (dBm)									
Channel No	Frequency (MHz)	Data Rate							Required Limit
		6	12	18	24	36	48	54	
36	5180	16.280	--	--	--	--	--	--	≤ 30
44	5220	16.900	16.760	16.630	16.500	16.360	16.230	16.080	≤ 30
48	5240	15.240	--	--	--	--	--	--	≤ 30

Channel 36 (5180MHz)

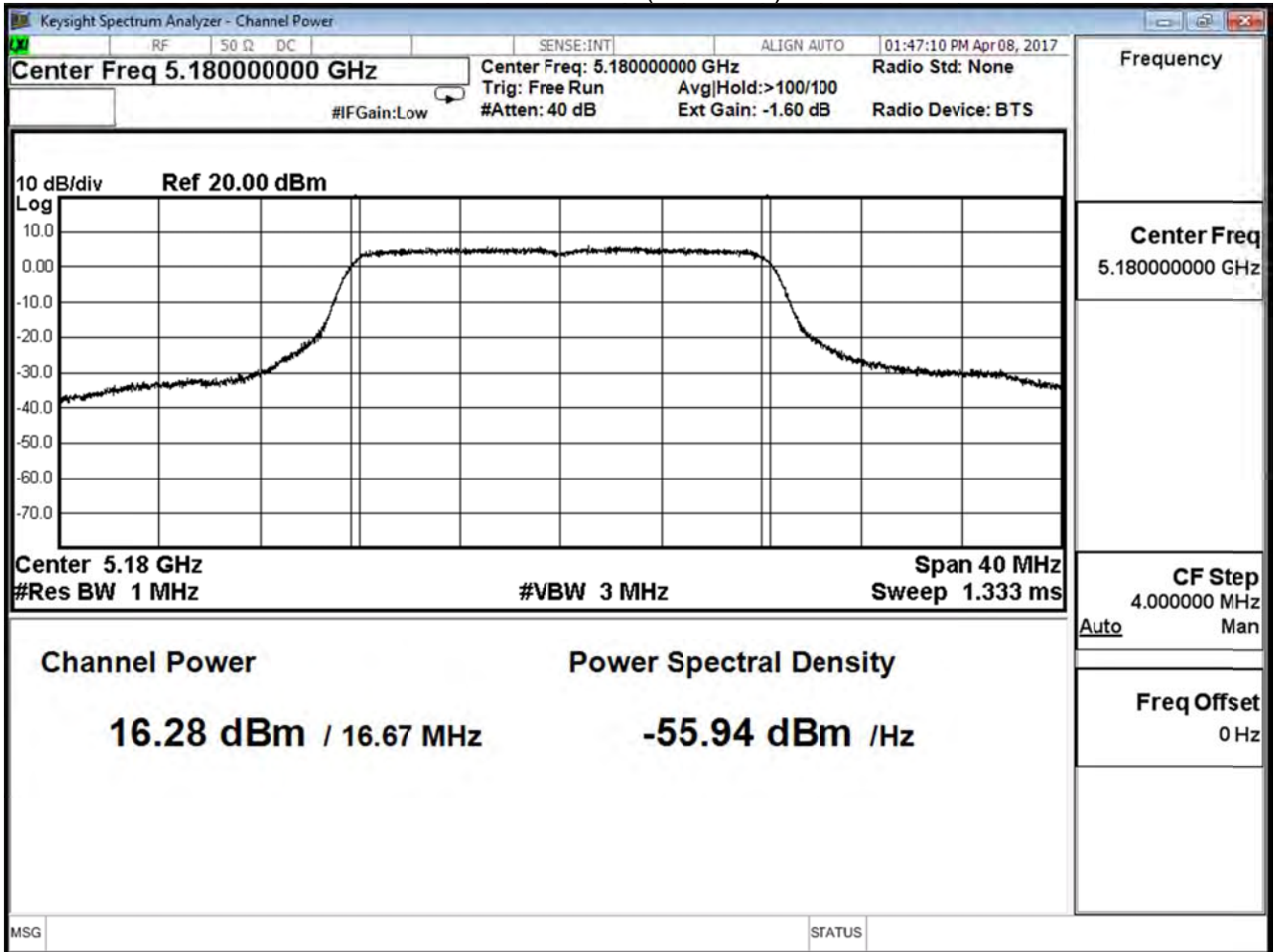

Channel 44 (5220MHz)

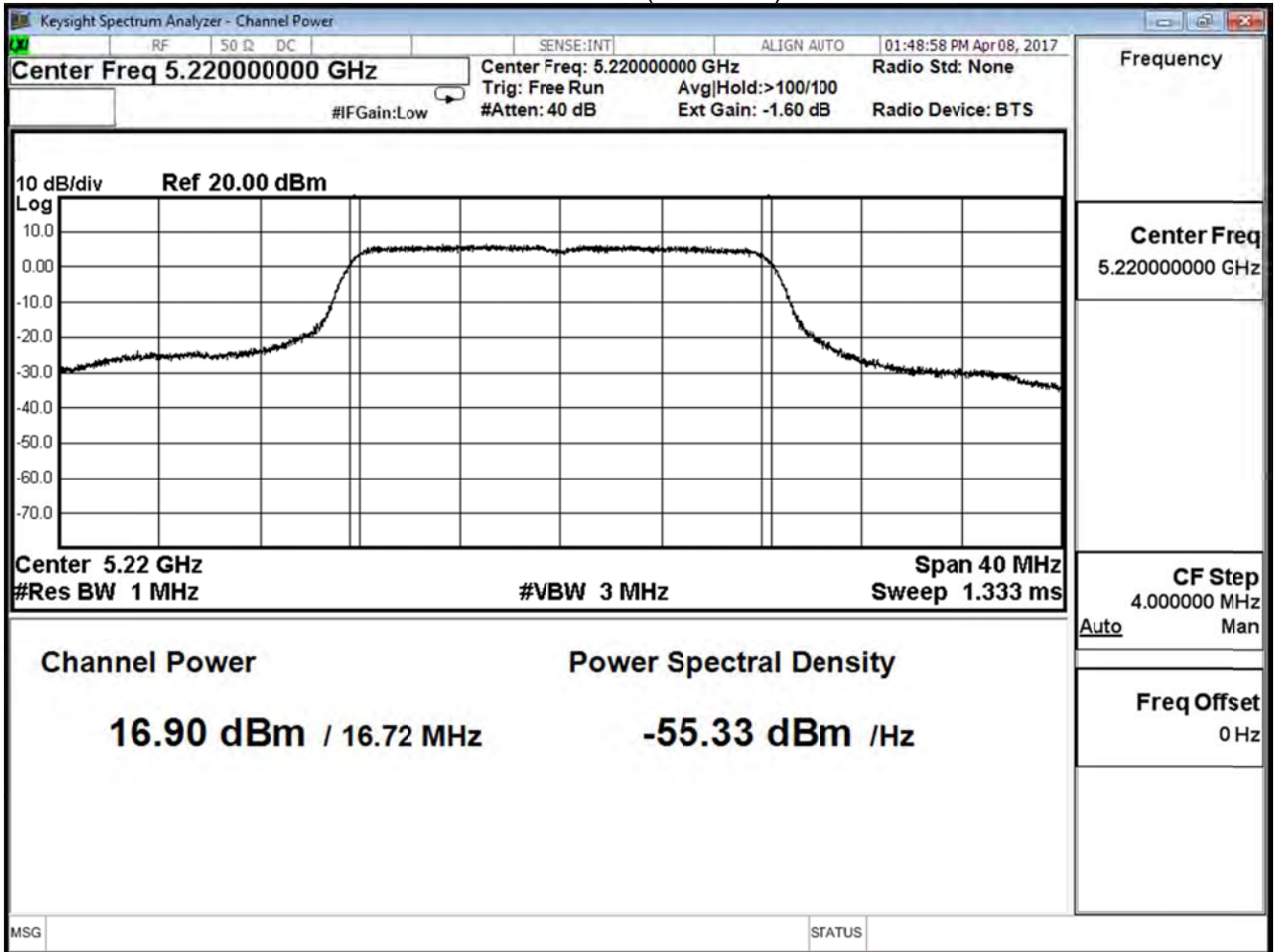

Channel 48 (5240MHz)

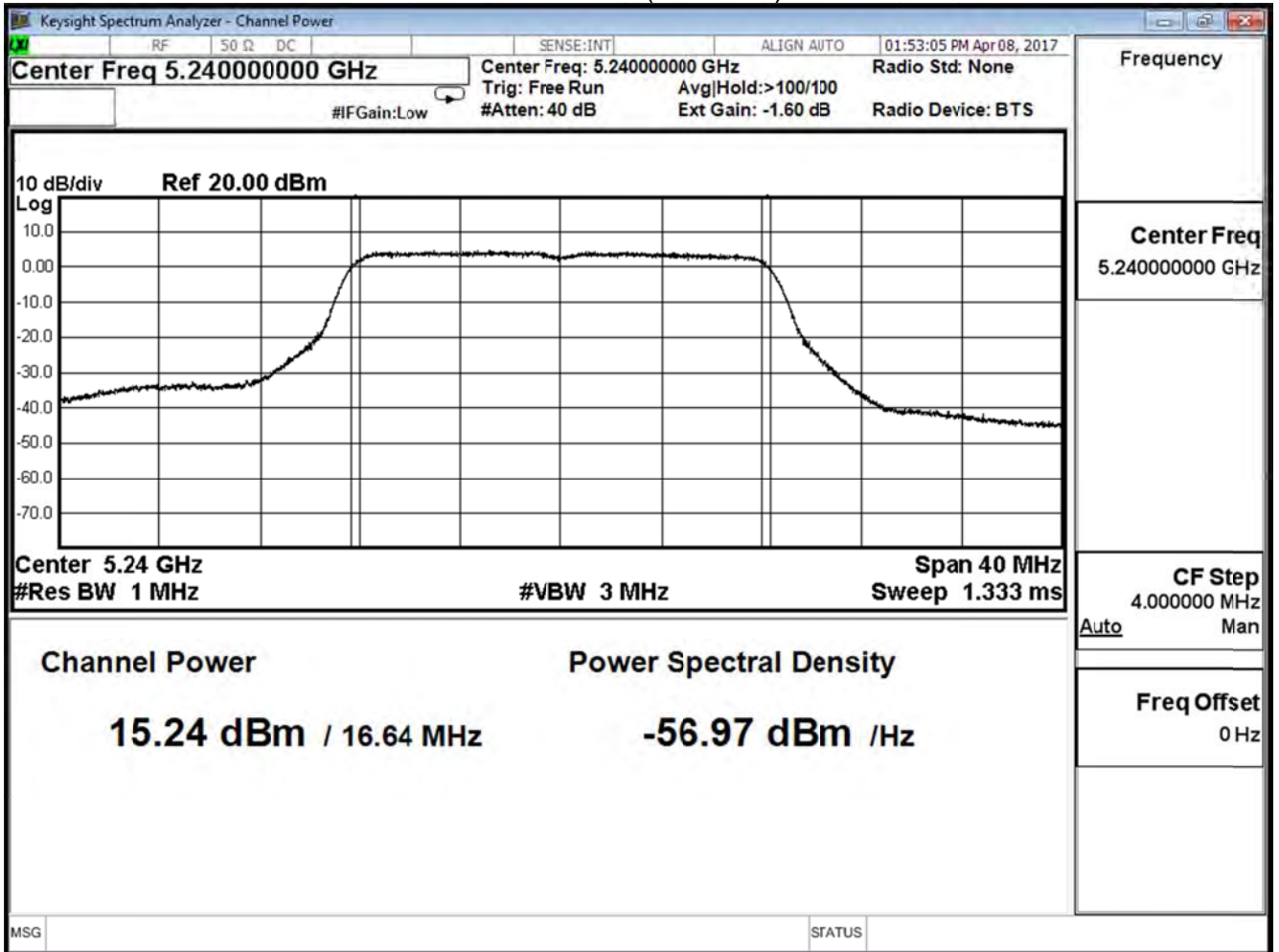

Product	Lyra		
Test Item	Peak Transmit Output		
Test Mode	Mode 1: Tx-AD2055320 Mode		
Date of Test	2017/04/08	Test Site	SR10-H

IEEE 802.11a (ANT 0+1)			
Channel No.	Frequency (MHz)	Measure Level (dBm)	Limit (dBm)
36	5180	19.148	≤ 30
44	5220	19.816	≤ 30
48	5240	18.142	≤ 30

Product	Lyra		
Test Item	Peak Transmit power		
Test Mode	Mode 1: Tx-AD2055320 Mode		
Date of Test	2017/04/08	Test Site	SR10-H

IEEE 802.11n20 (ANT 0)			
Channel No.	Frequency (MHz)	Measure Level (dBm)	Limit (dBm)
36	5180	15.130	≤ 30
44	5220	17.220	≤ 30
48	5240	15.000	≤ 30

The worst emission of MSC 8

Peak Power Output (dBm)										
MCS Index										Required Limit
Channel No	Frequency (MHz)	Data Rate								
		8	9	10	11	12	13	14	15	
36	5180	15.130	--	--	--	--	--	--	--	≤ 30
44	5220	17.220	17.080	16.940	16.790	16.640	16.500	16.350	16.210	≤ 30
48	5240	15.000	--	--	--	--	--	--	--	≤ 30

Channel 36 (5180MHz)

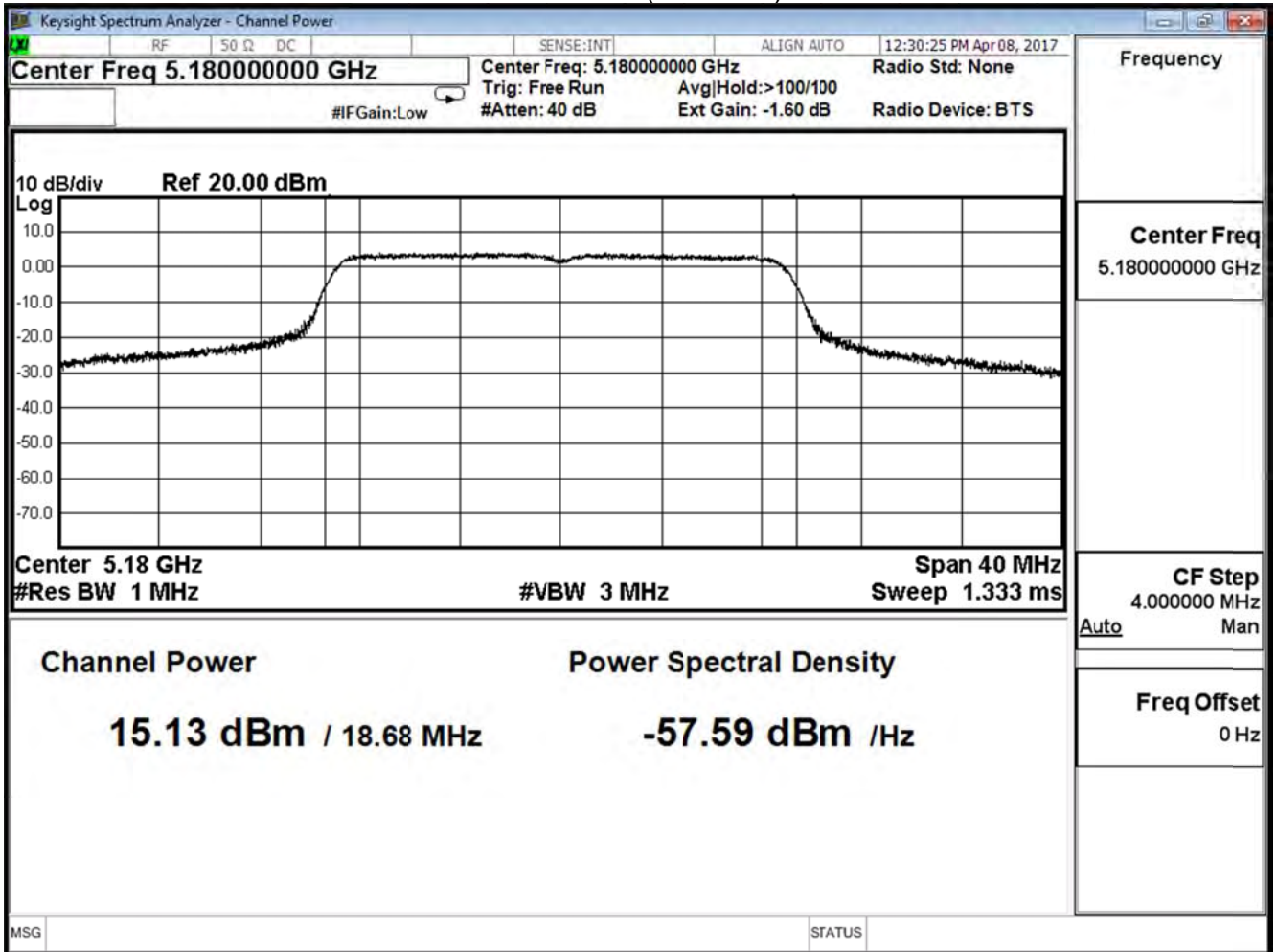

Channel 44 (5220MHz)

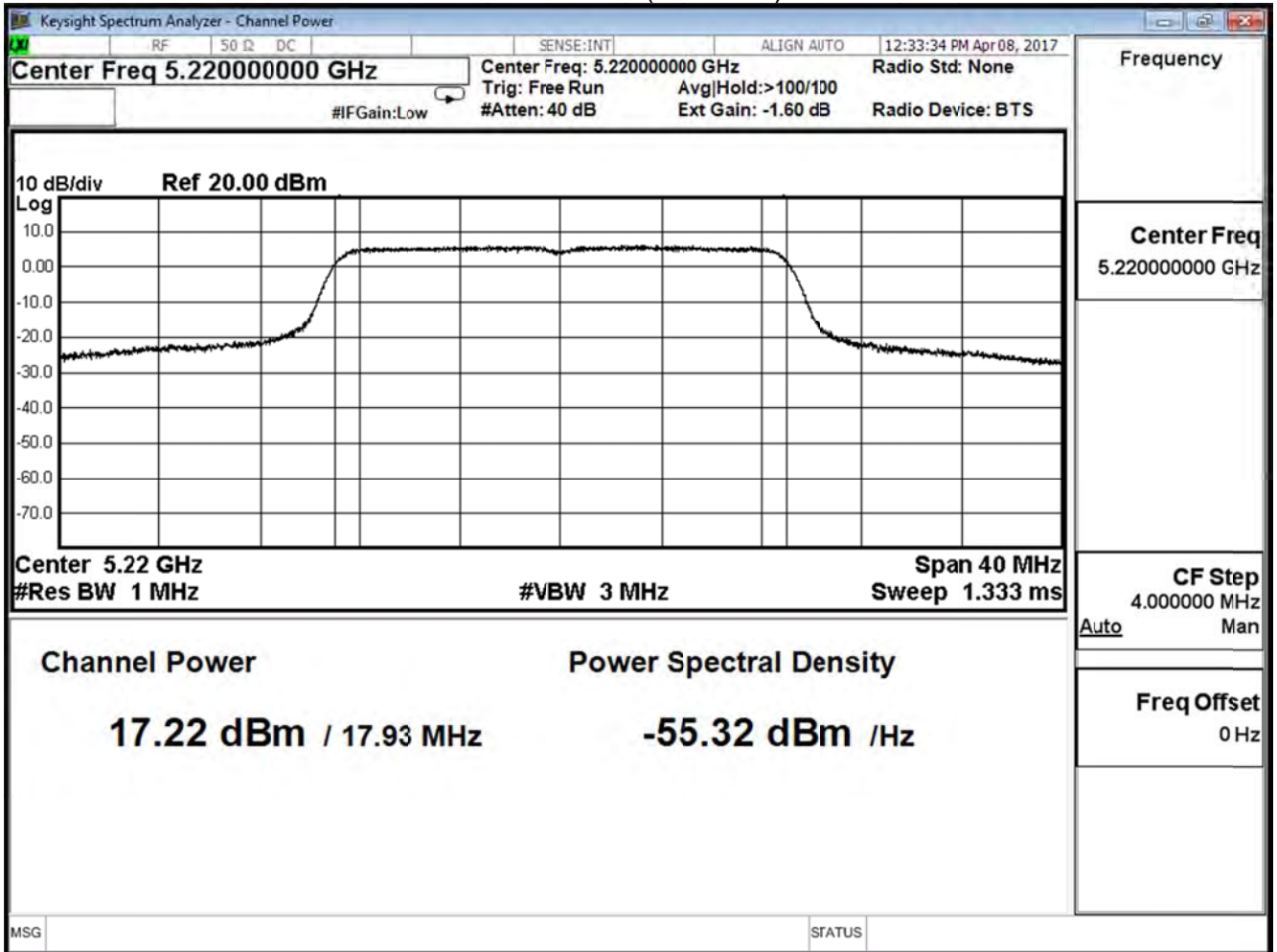

Channel 48 (5240MHz)

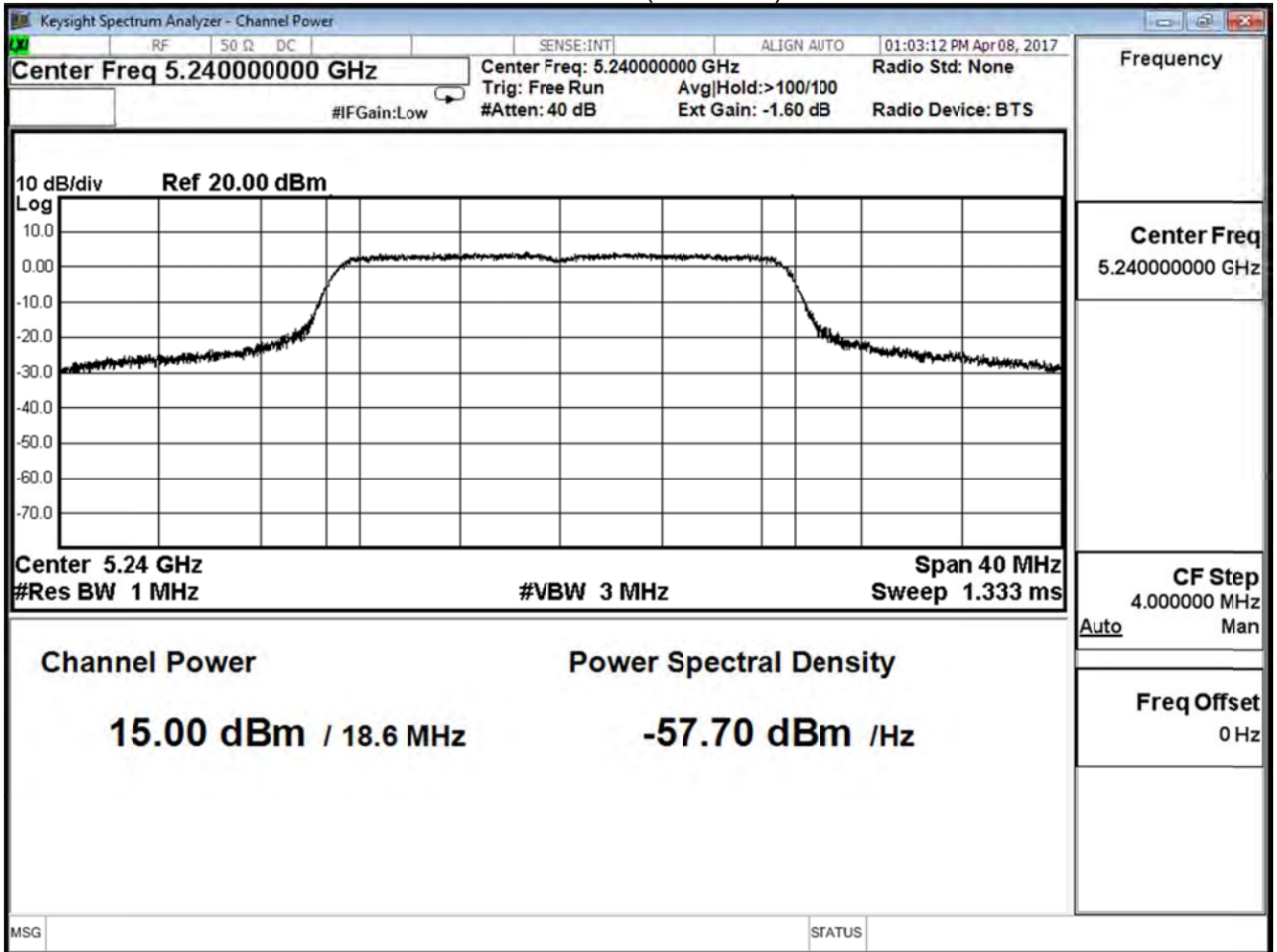

Product	Lyra		
Test Item	Peak Transmit power		
Test Mode	Mode 1: Tx-AD2055320 Mode		
Date of Test	2017/04/08	Test Site	SR10-H

IEEE 802.11n20 (ANT 1)			
Channel No.	Frequency (MHz)	Measure Level (dBm)	Limit (dBm)
36	5180	15.240	≤ 30
44	5220	17.430	≤ 30
48	5240	15.080	≤ 30

The worst emission of MSC 8

Peak Power Output (dBm)										
MCS Index										Required Limit
Channel No	Frequency (MHz)	Data Rate								
		8	9	10	11	12	13	14	15	
36	5180	15.240	--	--	--	--	--	--	--	≤ 30
44	5220	17.430	17.290	17.160	17.020	16.890	16.740	16.600	16.460	≤ 30
48	5240	15.080	--	--	--	--	--	--	--	≤ 30

Channel 36 (5180MHz)

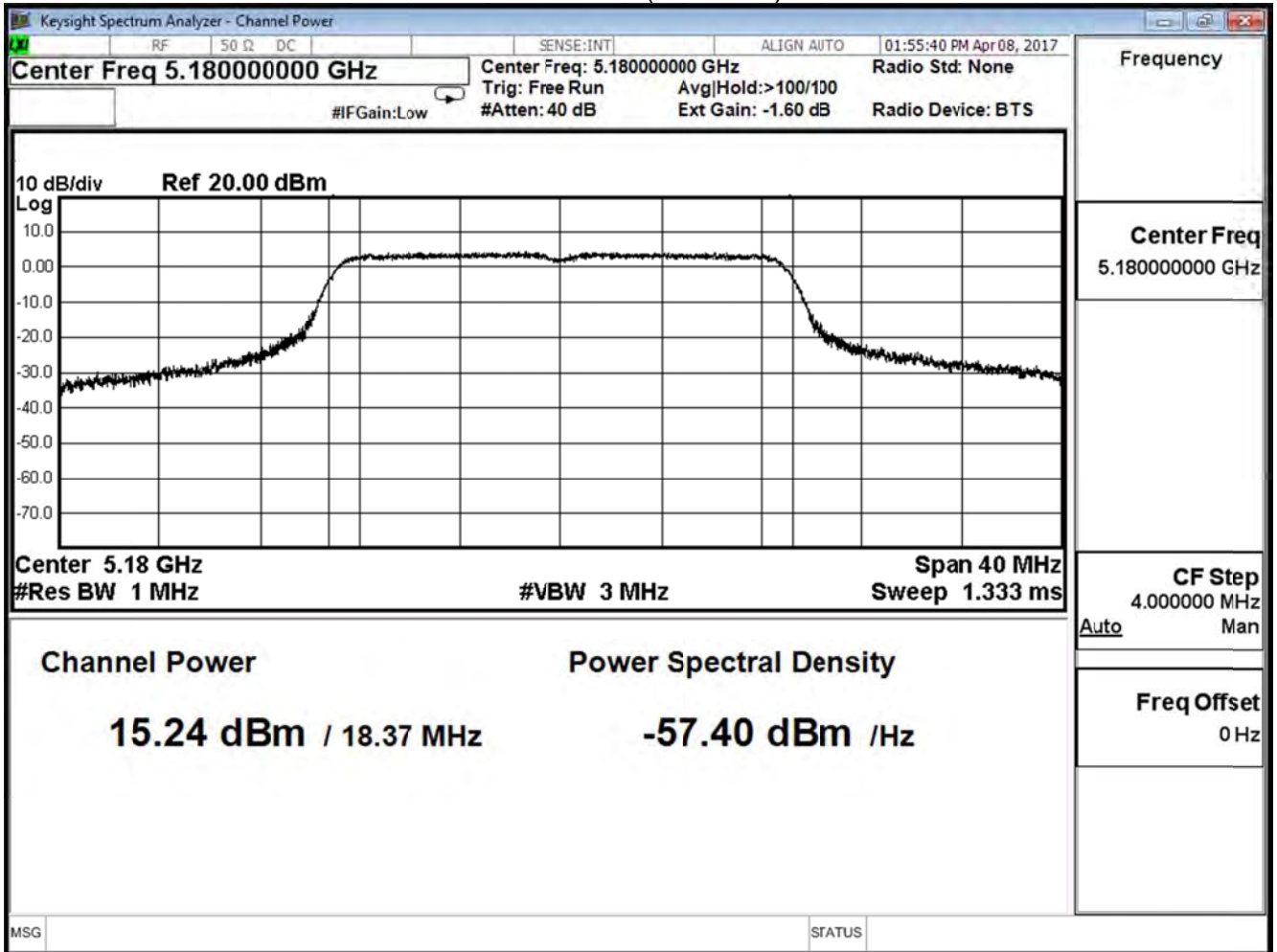

Channel 44 (5220MHz)

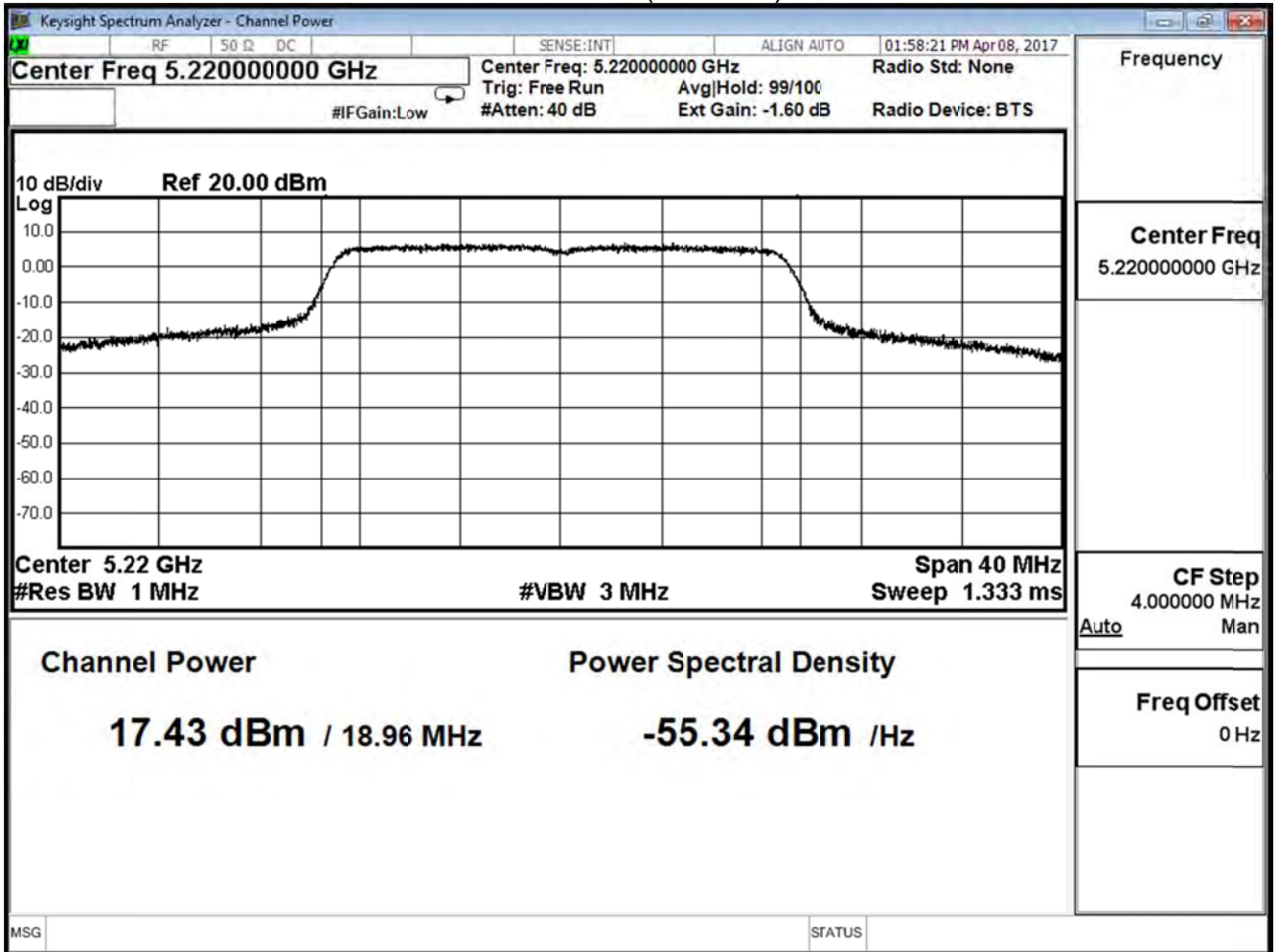

Channel 48 (5240MHz)

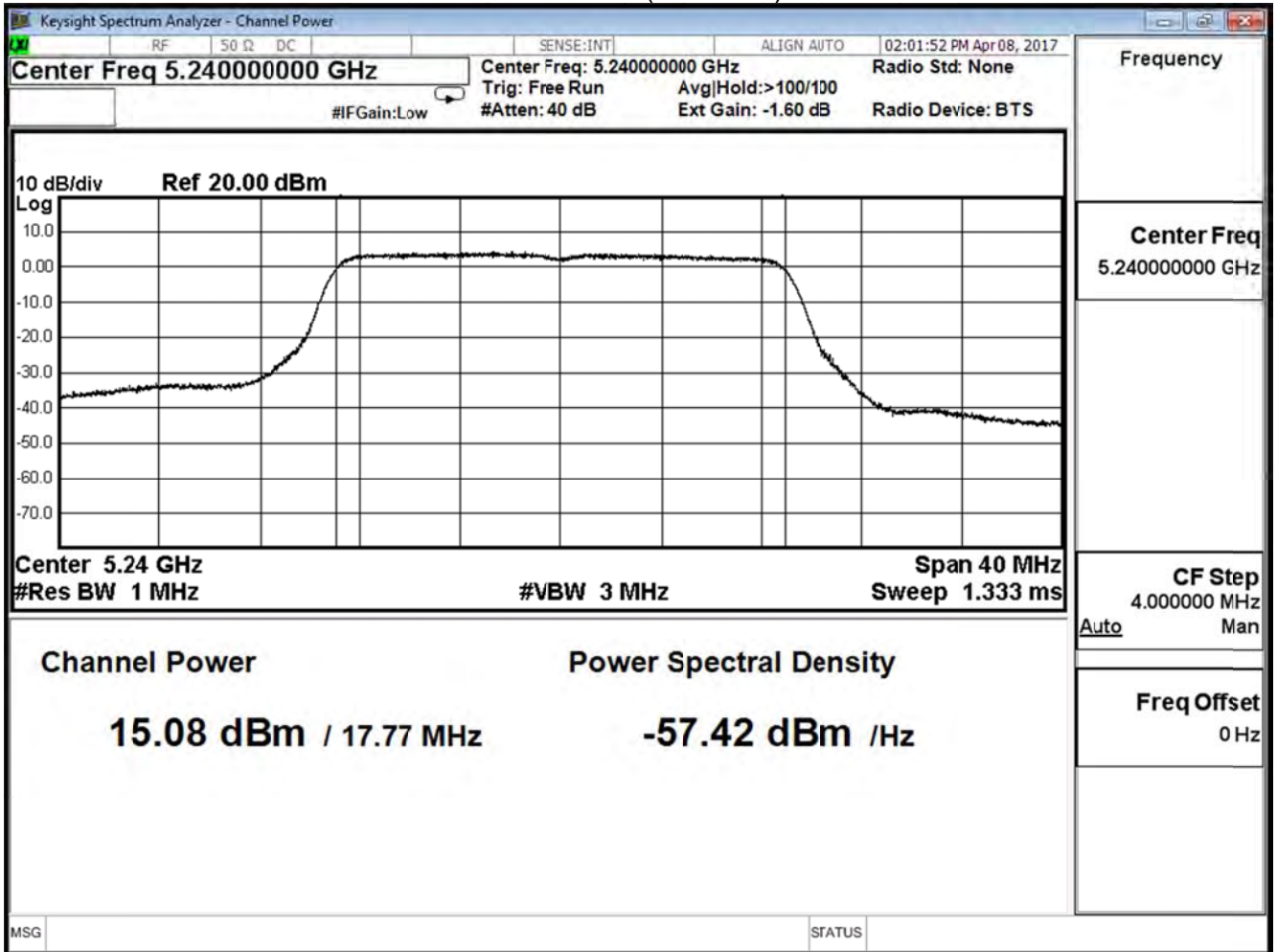

Product	Lyra		
Test Item	Peak Transmit power		
Test Mode	Mode 1: Tx-AD2055320 Mode		
Date of Test	2017/04/08	Test Site	SR10-H

IEEE 802.11n20 (ANT 0+1)			
Channel No.	Frequency (MHz)	Measure Level (dBm)	Limit (dBm)
36	5180	18.196	≤ 30
44	5220	20.337	≤ 30
48	5240	18.050	≤ 30

Product	Lyra		
Test Item	Peak Transmit power		
Test Mode	Mode 1: Tx-AD2055320 Mode		
Date of Test	2017/04/08	Test Site	SR10-H

IEEE 802.11n40 (ANT 0)			
Channel No.	Frequency (MHz)	Measure Level (dBm)	Limit (dBm)
38	5190	11.720	≤ 30
46	5230	13.810	≤ 30

The worst emission of MSC 8

Peak Power Output (dBm)										
MCS Index										Required Limit
Channel No	Frequency (MHz)	Data Rate								
		8	9	10	11	12	13	14	15	
38	5190	11.720	--	--	--	--	--	--	--	≤ 30
46	5230	13.810	13.670	13.530	13.380	13.240	13.100	12.960	12.820	≤ 30

Channel 38 (5190MHz)

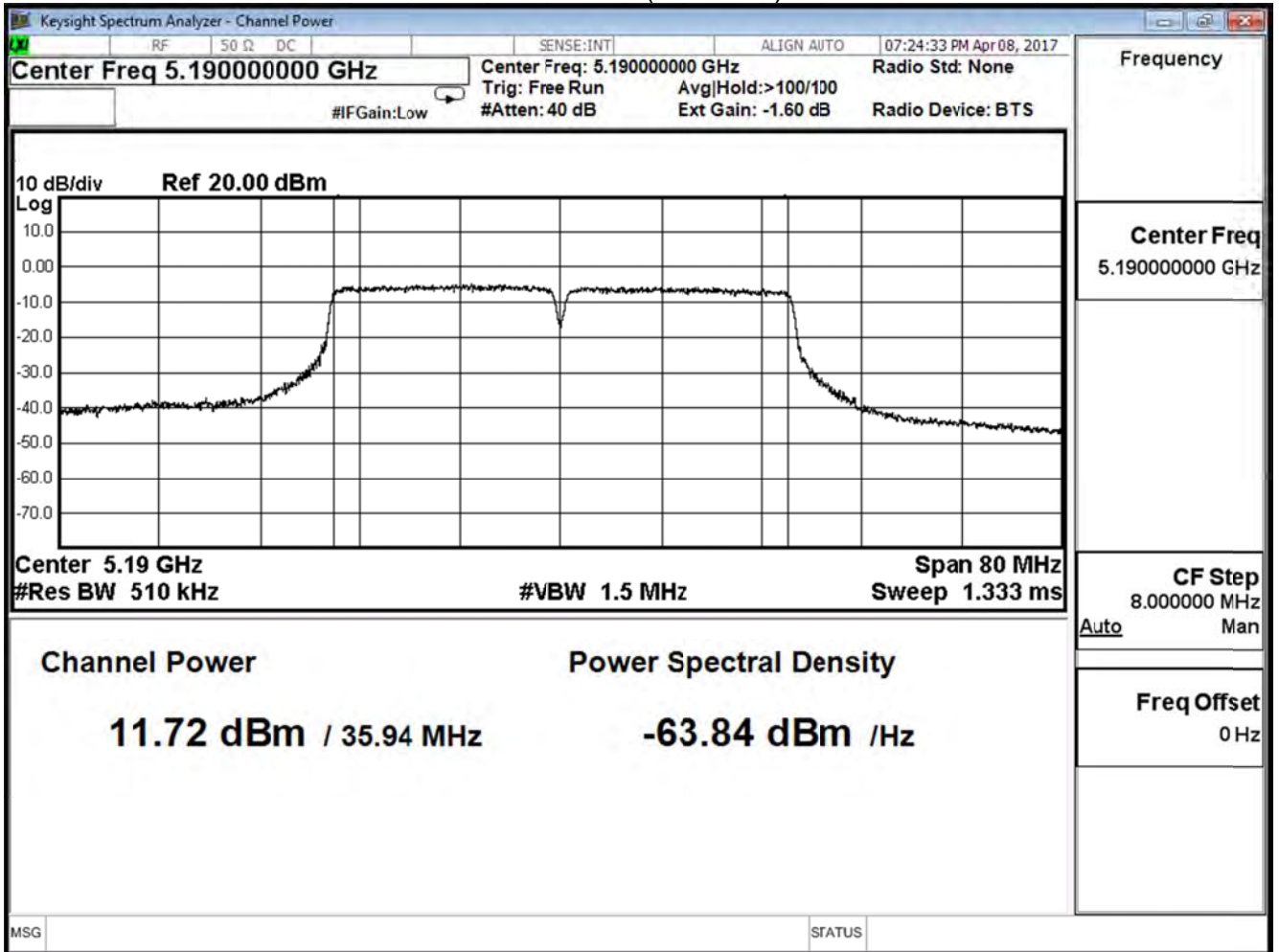

Channel 46 (5230MHz)

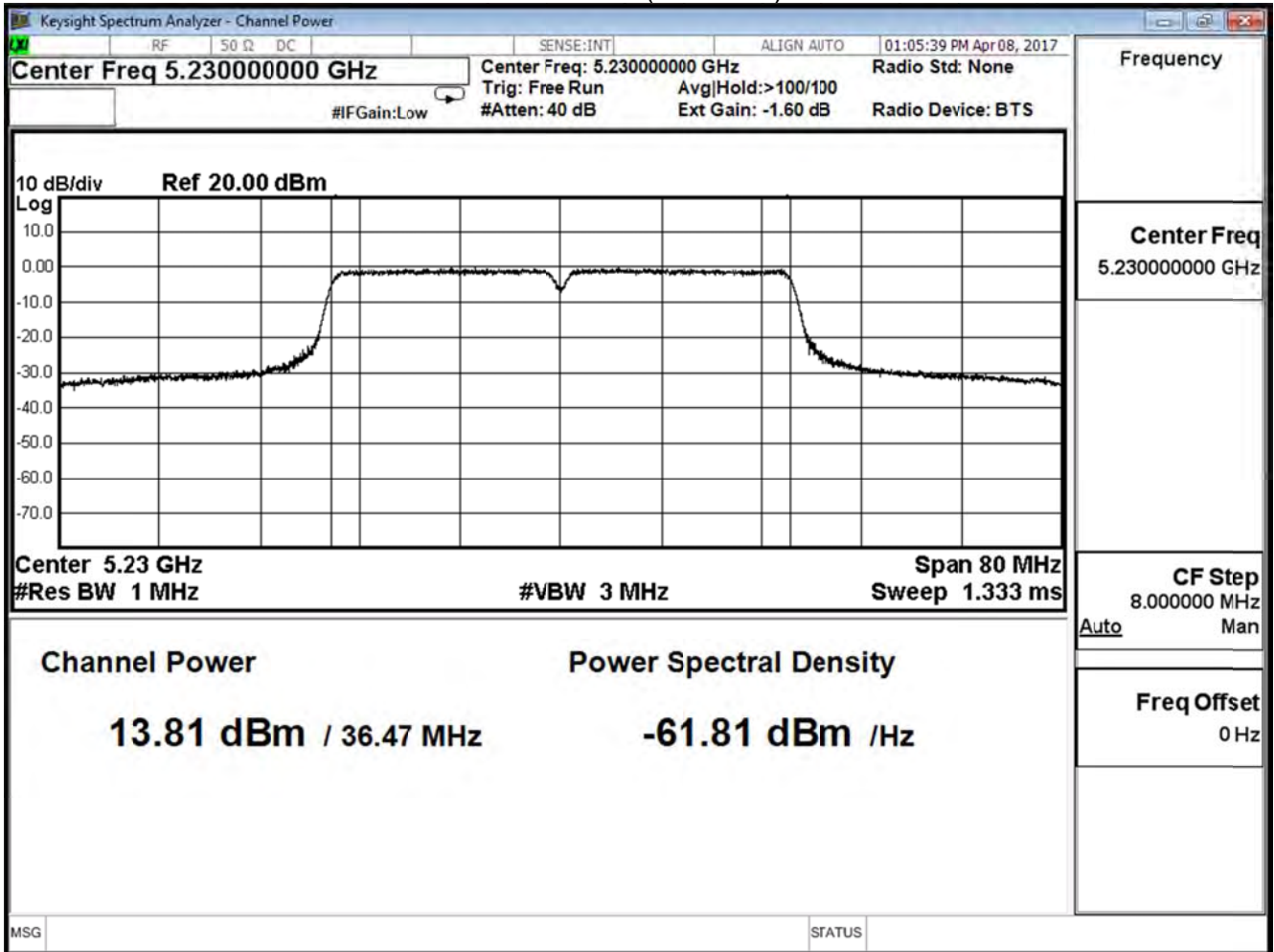

Product	Lyra		
Test Item	Peak Transmit power		
Test Mode	Mode 1: Tx-AD2055320 Mode		
Date of Test	2017/04/08	Test Site	SR10-H

IEEE 802.11n40 (ANT 1)			
Channel No.	Frequency (MHz)	Measure Level (dBm)	Limit (dBm)
38	5190	11.980	≤ 30
46	5230	14.240	≤ 30

The worst emission of MSC 8

Peak Power Output (dBm)										
MCS Index										Required Limit
Channel No	Frequency (MHz)	Data Rate								
		8	9	10	11	12	13	14	15	
38	5190	11.980	--	--	--	--	--	--	--	≤ 30
46	5230	14.240	14.110	13.970	13.820	13.670	13.530	13.390	13.240	≤ 30

Channel 38 (5190MHz)

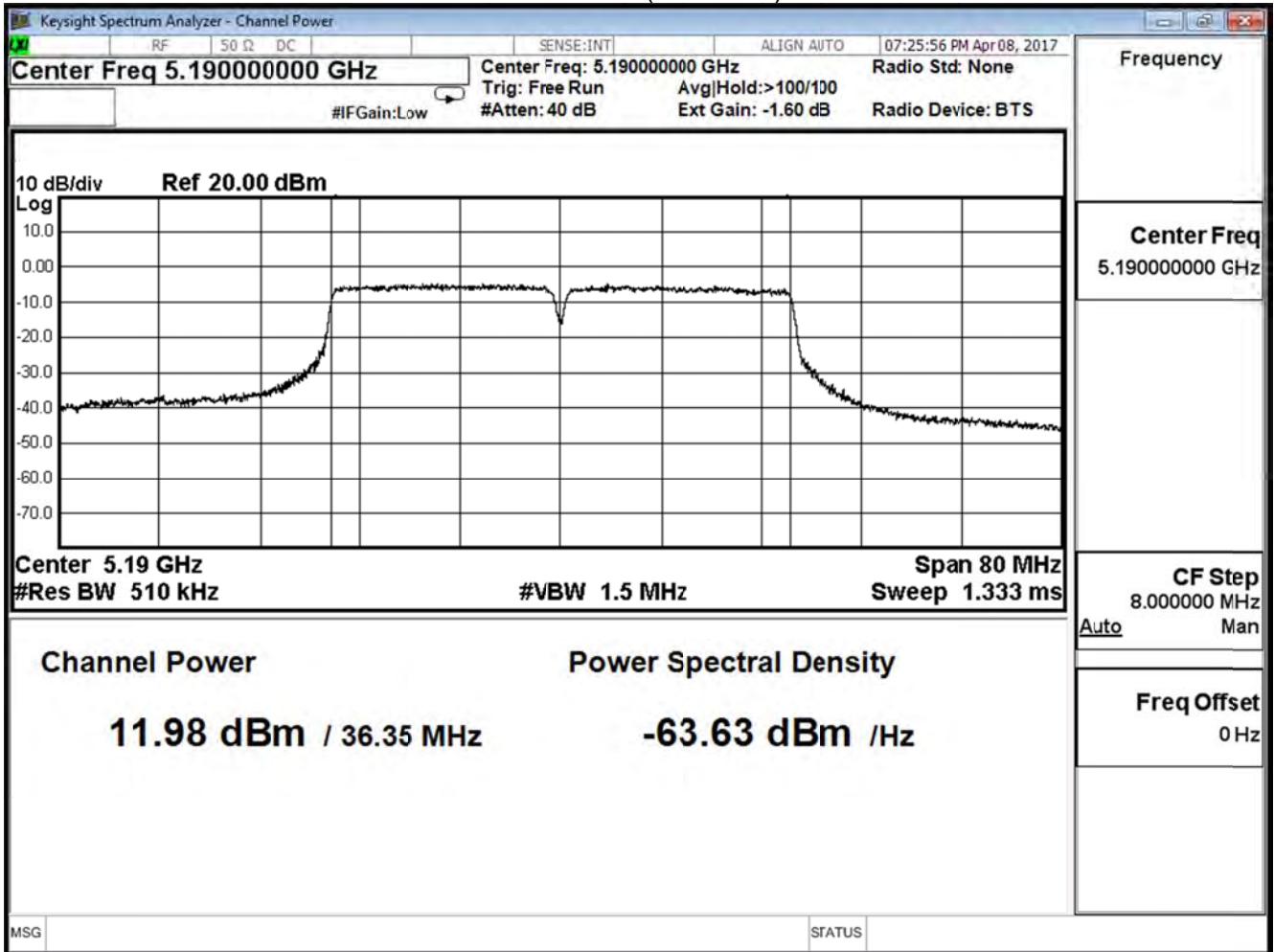

Channel 46 (5230MHz)

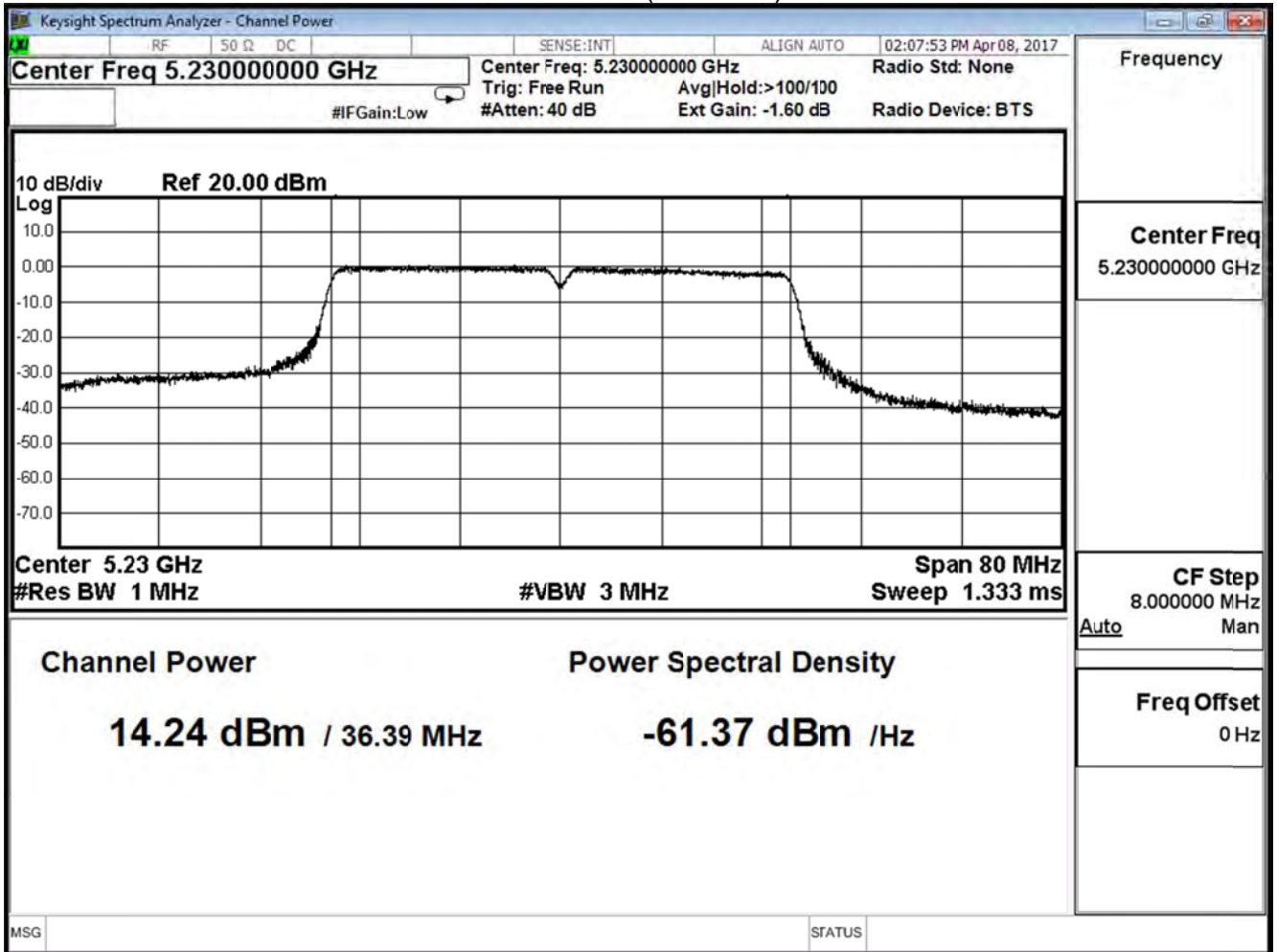

Product	Lyra		
Test Item	Peak Transmit power		
Test Mode	Mode 1: Tx-AD2055320 Mode		
Date of Test	2017/04/08	Test Site	SR10-H

IEEE 802.11n40 (ANT 0+1)			
Channel No.	Frequency (MHz)	Measure Level (dBm)	Limit (dBm)
38	5190	14.862	≤ 30
46	5230	17.041	≤ 30

Product	Lyra		
Test Item	Peak Transmit power		
Test Mode	Mode 1: Tx-AD2055320 Mode		
Date of Test	2017/04/08	Test Site	SR7

IEEE 802.11ac80 (ANT 0)			
Channel No.	Frequency (MHz)	Measure Level (dBm)	Limit (dBm)
42	5210	8.990	≤ 30

The worst emission of MSC 0

Peak Power Output (dBm)												
MCS Index											Require Limit	
Channel No	Frequency (MHz)	Data Rate										≤ 30
		0	1	2	3	4	5	6	7	8	9	
42	5210	8.990	8.860	8.730	8.580	8.440	8.300	8.170	8.030	7.900	7.750	

Channel 42 (5210MHz)

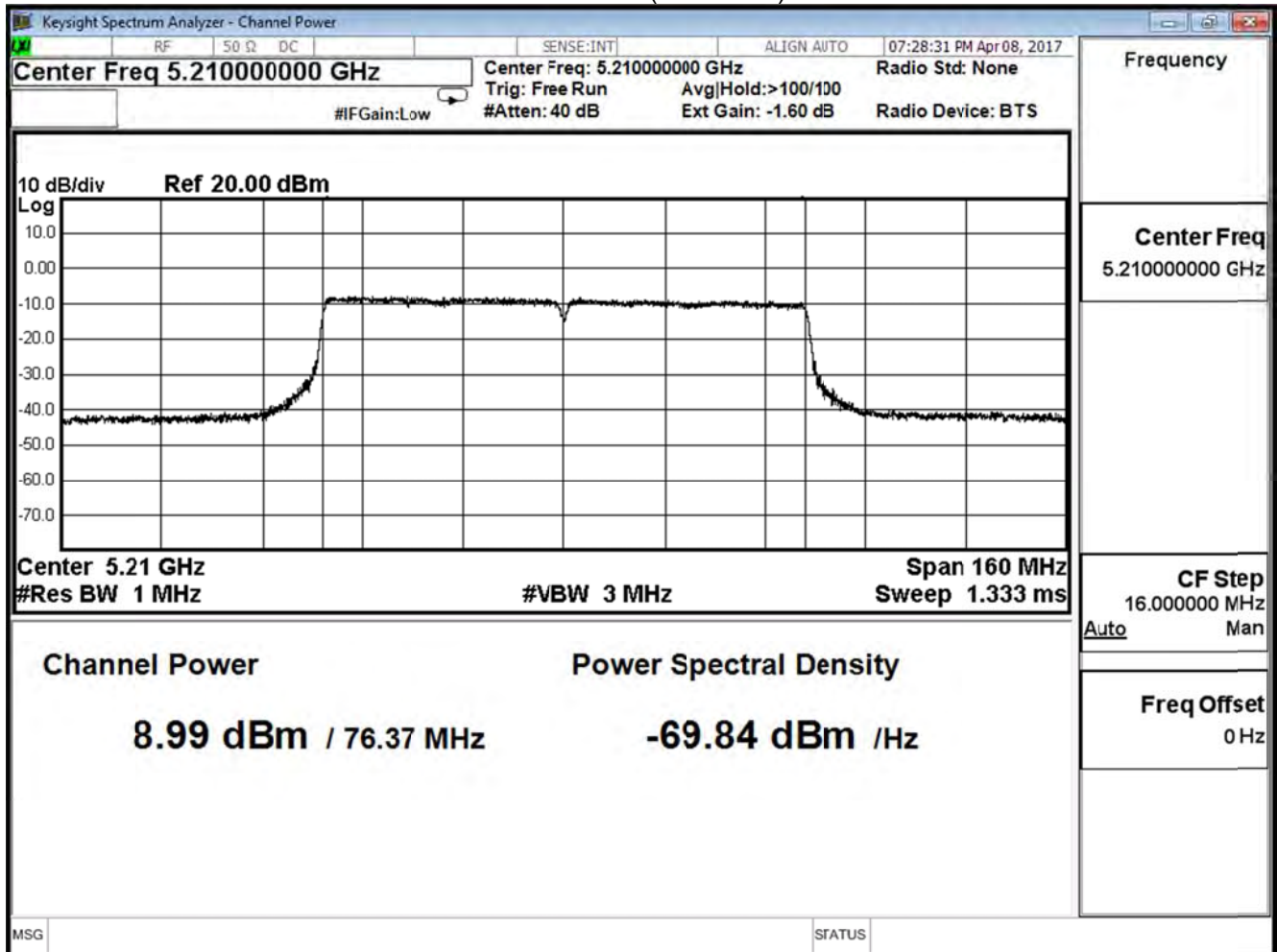

Product	Lyra		
Test Item	Peak Transmit power		
Test Mode	Mode 1: Tx-AD2055320 Mode		
Date of Test	2017/04/08	Test Site	SR10-H

IEEE 802.11ac80 (ANT 1)			
Channel No.	Frequency (MHz)	Measure Level (dBm)	Limit (dBm)
42	5210	9.330	≤ 30

The worst emission of MSC 0

Peak Power Output (dBm)												
MCS Index												Require Limit
Channel No	Frequency (MHz)	Data Rate										
		0	1	2	3	4	5	6	7	8	9	
42	5210	9.330	9.200	9.060	8.920	8.770	8.630	8.490	8.350	8.210	8.070	≤ 30

Channel 42 (5210MHz)

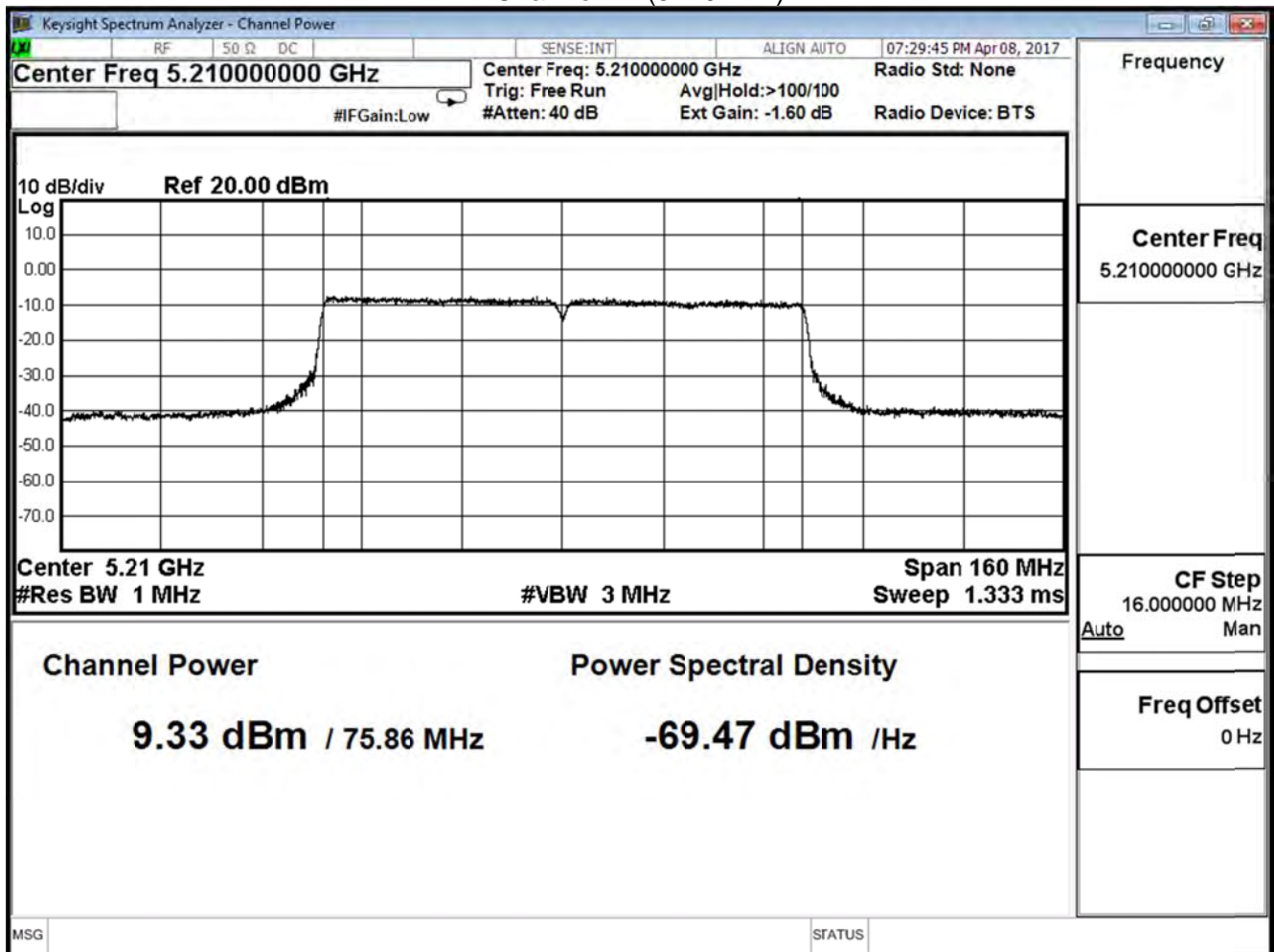

Product	Lyra		
Test Item	Peak Transmit power		
Test Mode	Mode 1: Tx-AD2055320 Mode		
Date of Test	2017/04/08	Test Site	SR10-H

IEEE 802.11ac80 (ANT 0+1)			
Channel No.	Frequency (MHz)	Measure Level (dBm)	Limit (dBm)
42	5210	12.174	≤ 30

Product	Lyra		
Test Item	Peak Transmit power		
Test Mode	Mode 2: Tx-AD2055320 BF Mode		
Date of Test	2017/04/08	Test Site	SR10-H

IEEE 802.11n20 (ANT 0)			
Channel No.	Frequency (MHz)	Measure Level (dBm)	Limit (dBm)
36	5180	15.130	≤ 28.68
44	5220	17.220	≤ 28.68
48	5240	15.000	≤ 28.68

Peak Power Output (dBm)										
MCS Index										Required Limit
Channel No	Frequency (MHz)	Data Rate								
		8	9	10	11	12	13	14	15	
36	5180	15.130	--	--	--	--	--	--	--	≤ 28.68
44	5220	17.220	17.090	16.960	16.810	16.670	16.520	16.390	16.250	≤ 28.68
48	5240	15.000	--	--	--	--	--	--	--	≤ 28.68

Note:

Directional Antenna= $10\log(N)+\text{Max Gain}=3.01+4.31\text{dBi}=7.32\text{dBi}$

Required Limit= $30\text{dBm}-(7.32\text{dBi}-6\text{dB})=28.68\text{dBm}$

Channel 36 (5180MHz)

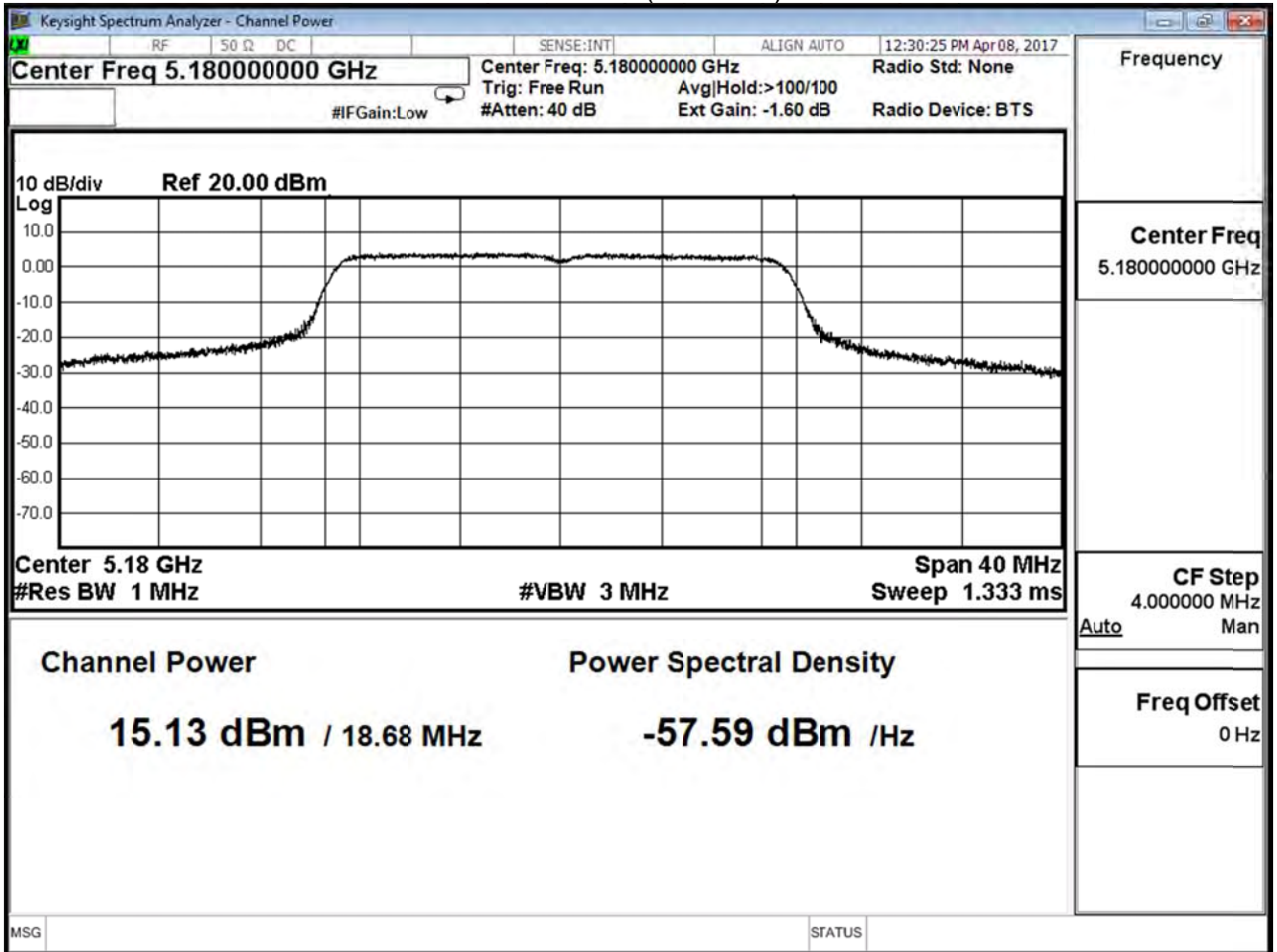

Channel 44 (5220MHz)

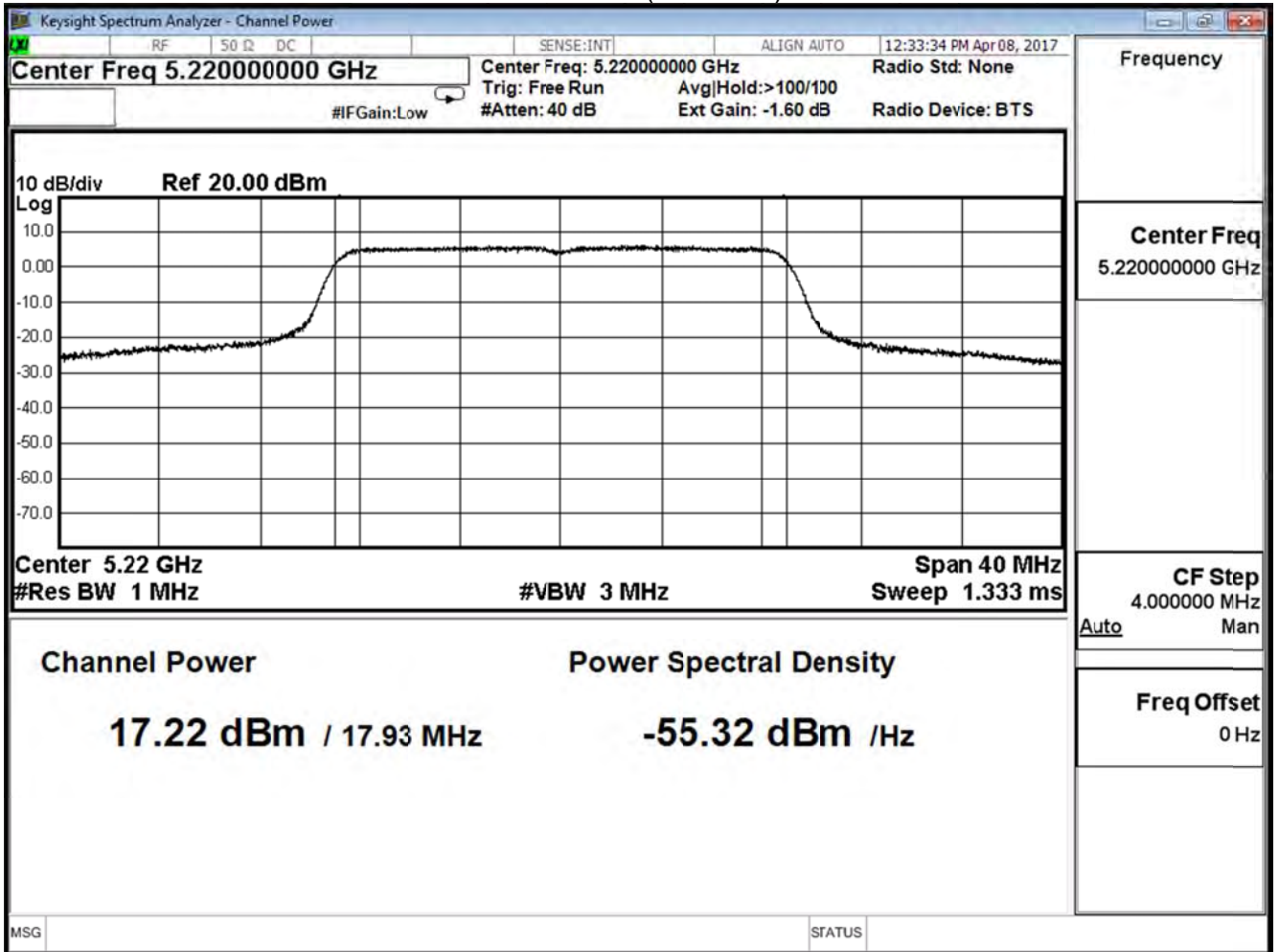

Channel 48 (5240MHz)

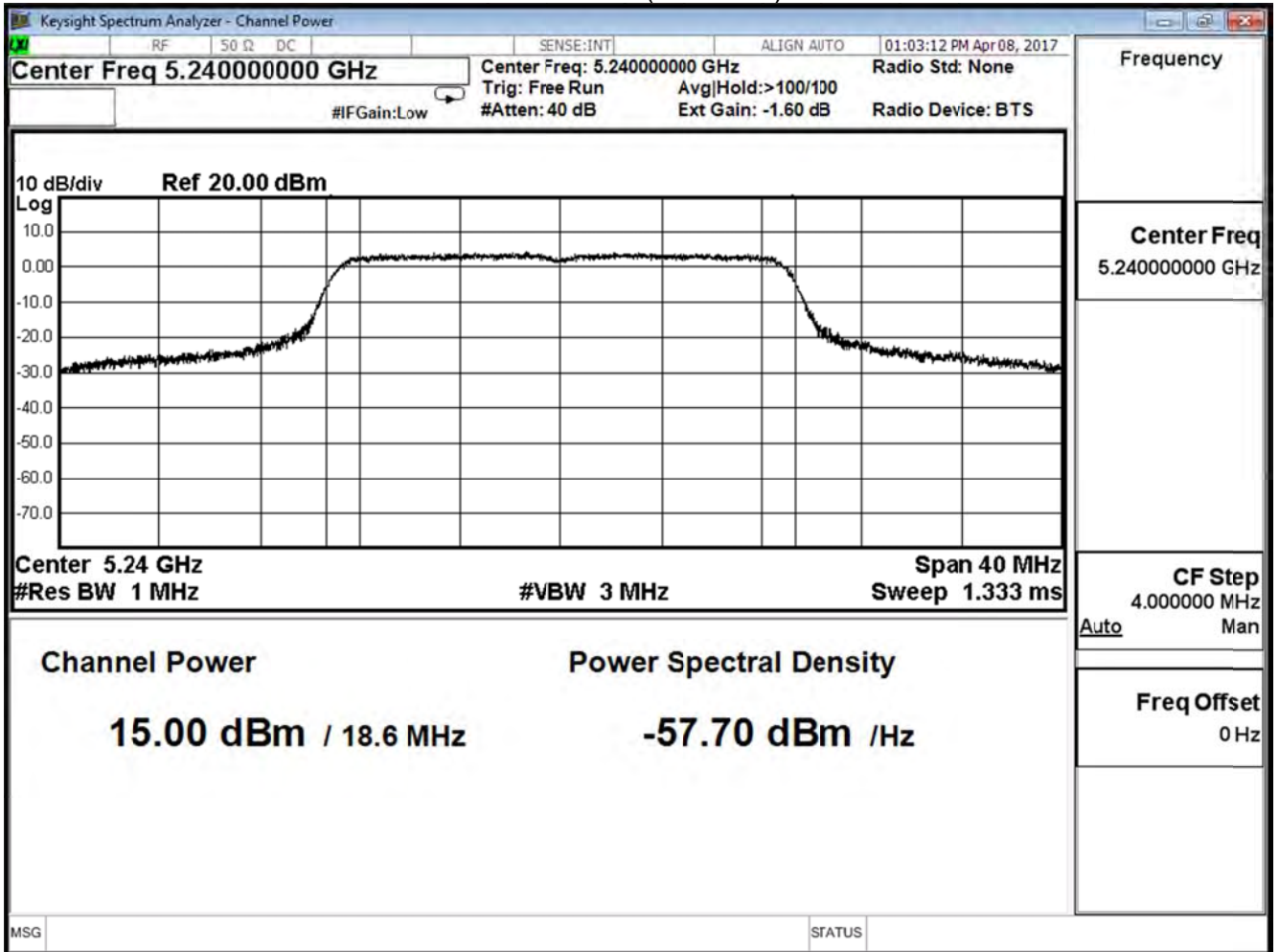

Product	Lyra		
Test Item	Peak Transmit power		
Test Mode	Mode 2: Tx-AD2055320 BF Mode		
Date of Test	2017/04/08	Test Site	SR10-H

IEEE 802.11n20 (ANT 1)			
Channel No.	Frequency (MHz)	Measure Level (dBm)	Limit (dBm)
36	5180	15.240	≤ 28.68
44	5220	17.430	≤ 28.68
48	5240	15.080	≤ 28.68

Peak Power Output (dBm)										
MCS Index										Required Limit
Channel No	Frequency (MHz)	Data Rate								
		8	9	10	11	12	13	14	15	
36	5180	15.240	--	--	--	--	--	--	--	≤ 28.68
44	5220	17.430	17.290	17.150	17.010	16.870	16.720	16.590	16.440	≤ 28.68
48	5240	15.080	--	--	--	--	--	--	--	≤ 28.68

Note:

Directional Antenna=10log(N)+Max Gain=3.01+4.31dBi=7.32dBi

Required Limit=30dBm-(7.32dBi-6dB)=28.68dBm

Channel 36 (5180MHz)

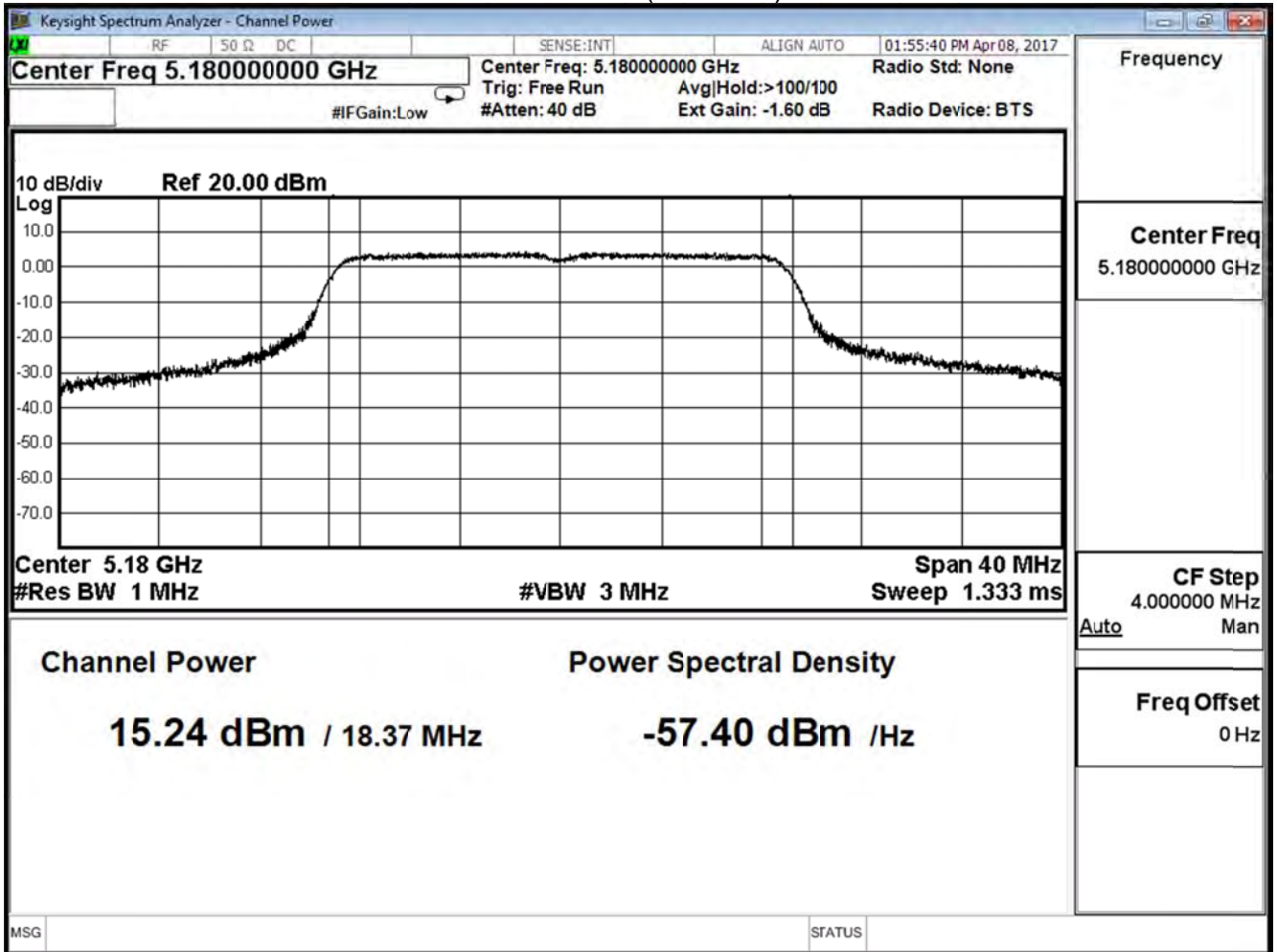

Channel 44 (5220MHz)

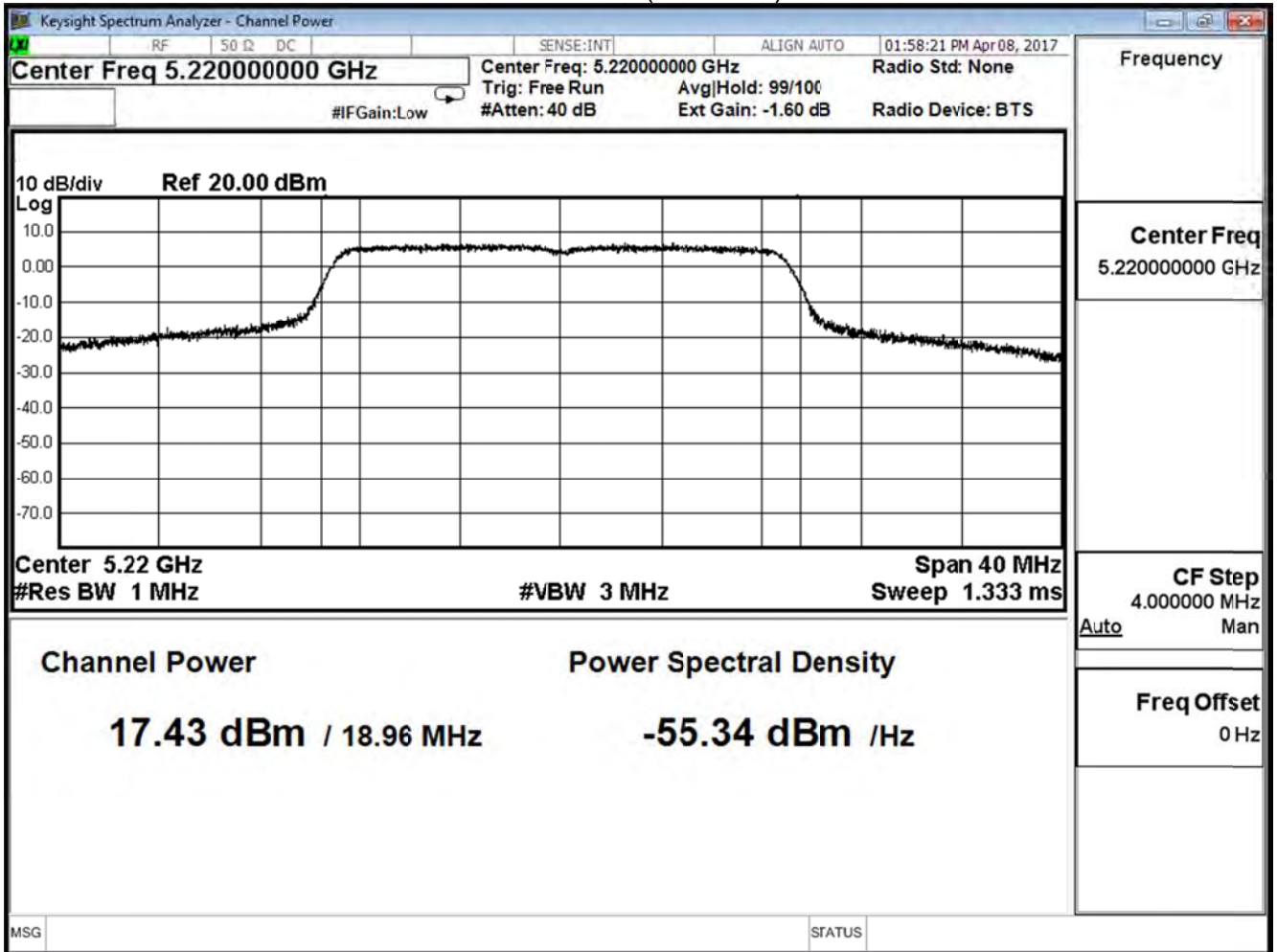

Channel 48 (5240MHz)

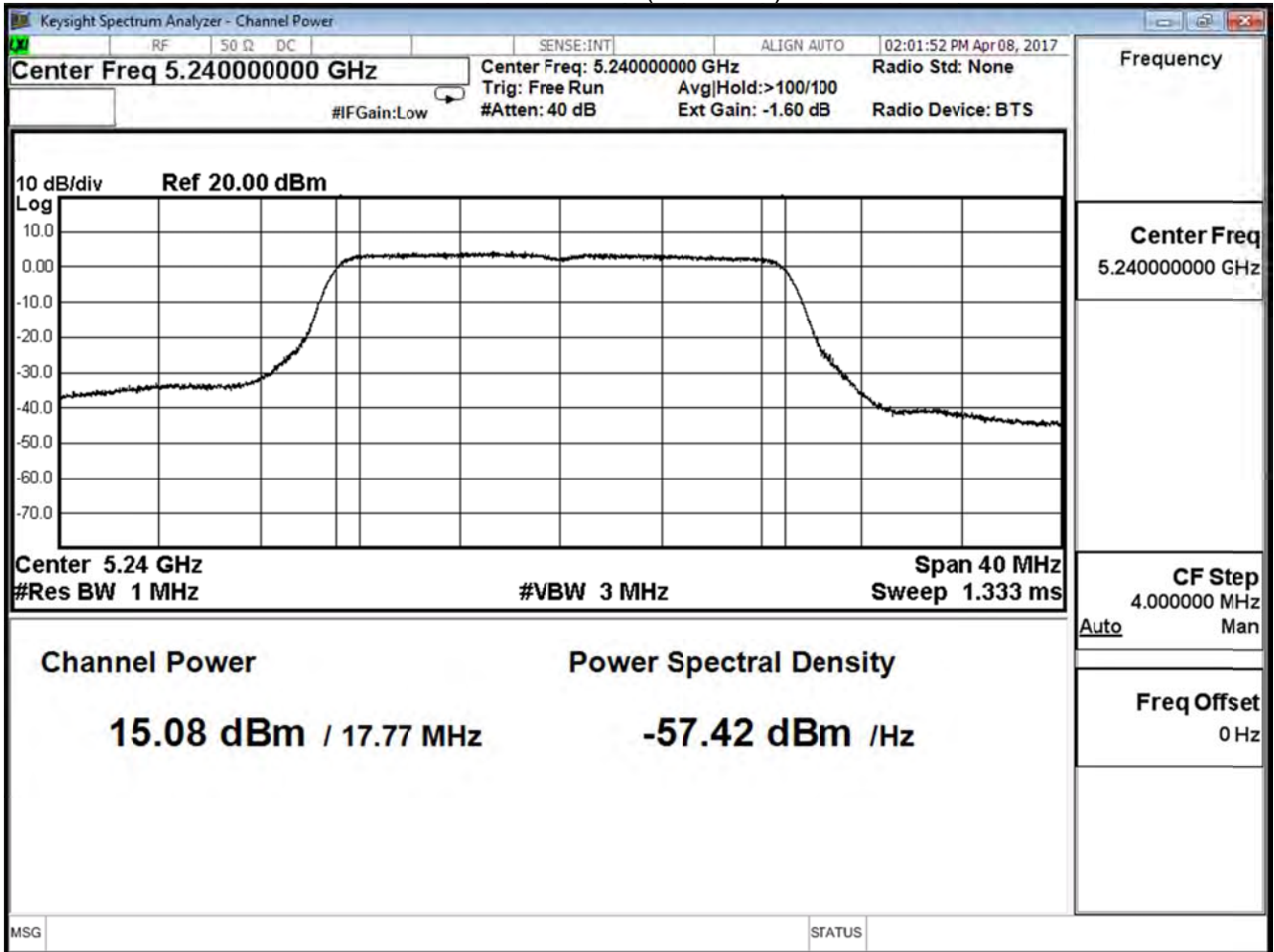

Product	Lyra		
Test Item	Peak Transmit power		
Test Mode	Mode 2: Tx-AD2055320 BF Mode		
Date of Test	2017/04/08	Test Site	SR10-H

IEEE 802.11n20 (ANT 0+1)			
Channel No.	Frequency (MHz)	Measure Level (dBm)	Limit (dBm)
36	5180	18.196	≤ 28.68
44	5220	20.337	≤ 28.68
48	5240	18.050	≤ 28.68

Note:

Directional Antenna= $10\log(N)+\text{Max Gain}=3.01+4.31\text{dBi}=7.32\text{dBi}$

Required Limit= $30\text{dBm}-(7.32\text{dBi}-6\text{dB})=28.68\text{dBm}$

Product	Lyra		
Test Item	Peak Transmit power		
Test Mode	Mode 2: Tx-AD2055320 BF Mode		
Date of Test	2017/04/08	Test Site	SR10-H

IEEE 802.11n40 (ANT 0)			
Channel No.	Frequency (MHz)	Measure Level (dBm)	Limit (dBm)
38	5190	11.100	≤ 28.68
46	5230	13.810	≤ 28.68

Peak Power Output (dBm)										
MCS Index										Required Limit
Channel No	Frequency (MHz)	Data Rate								
		8	9	10	11	12	13	14	15	
38	5190	11.100	--	--	--	--	--	--	--	≤ 28.68
46	5230	13.810	13.670	13.530	13.390	13.260	13.110	12.970	12.840	≤ 28.68

Note:

Directional Antenna=10log(N)+Max Gain=3.01+4.31dBi=7.32dBi

Required Limit=30dBm-(7.32dBi-6dB)=28.68dBm

Channel 38 (5190MHz)

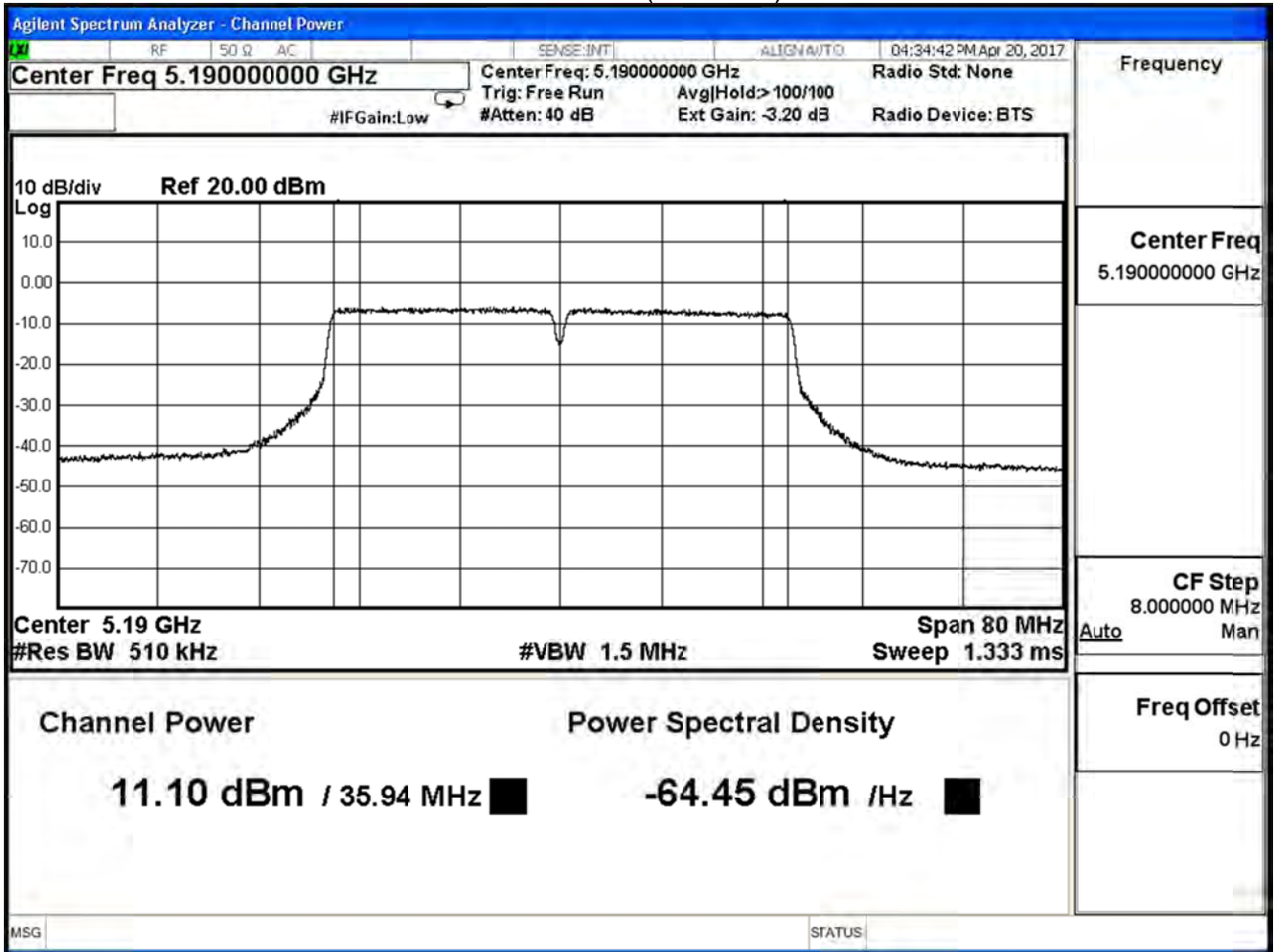

Channel 46 (5230MHz)

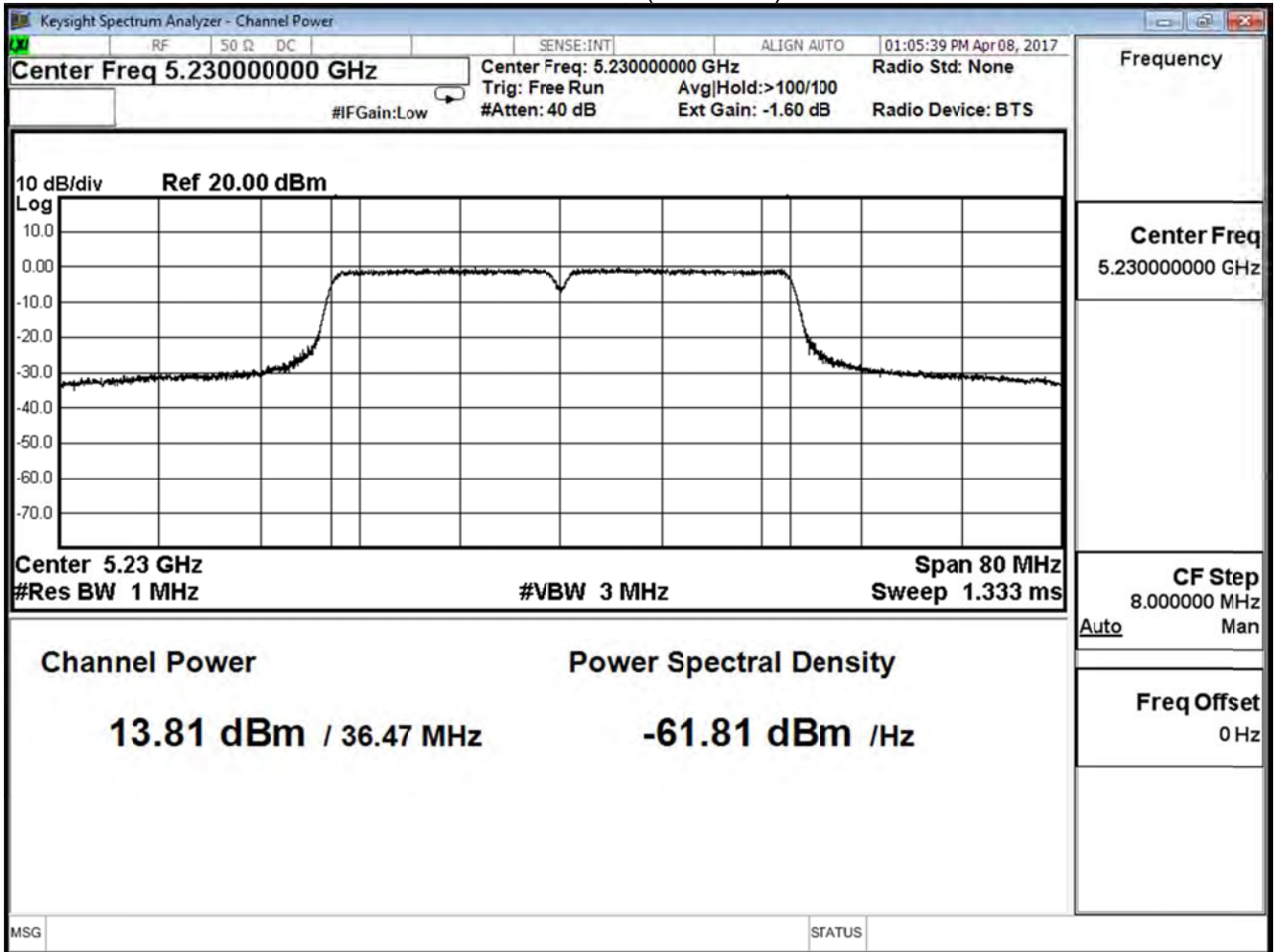

Product	Lyra		
Test Item	Peak Transmit power		
Test Mode	Mode 2: Tx-AD2055320 BF Mode		
Date of Test	2017/04/08	Test Site	SR10-H

IEEE 802.11n40 (ANT 1)			
Channel No.	Frequency (MHz)	Measure Level (dBm)	Limit (dBm)
38	5190	11.330	≤ 28.68
46	5230	14.240	≤ 28.68

Peak Power Output (dBm)										
MCS Index										Required Limit
Channel No	Frequency (MHz)	Data Rate								
		8	9	10	11	12	13	14	15	
38	5190	11.330	--	--	--	--	--	--	--	≤ 28.68
46	5230	14.240	14.090	13.960	13.830	13.690	13.550	13.420	13.280	≤ 28.68

Note:
 Directional Antenna=10log(N)+Max Gain=3.01+4.31dBi=7.32dBi
 Required Limit=30dBm-(7.32dBi-6dB)=28.68dBm

Channel 38 (5190MHz)

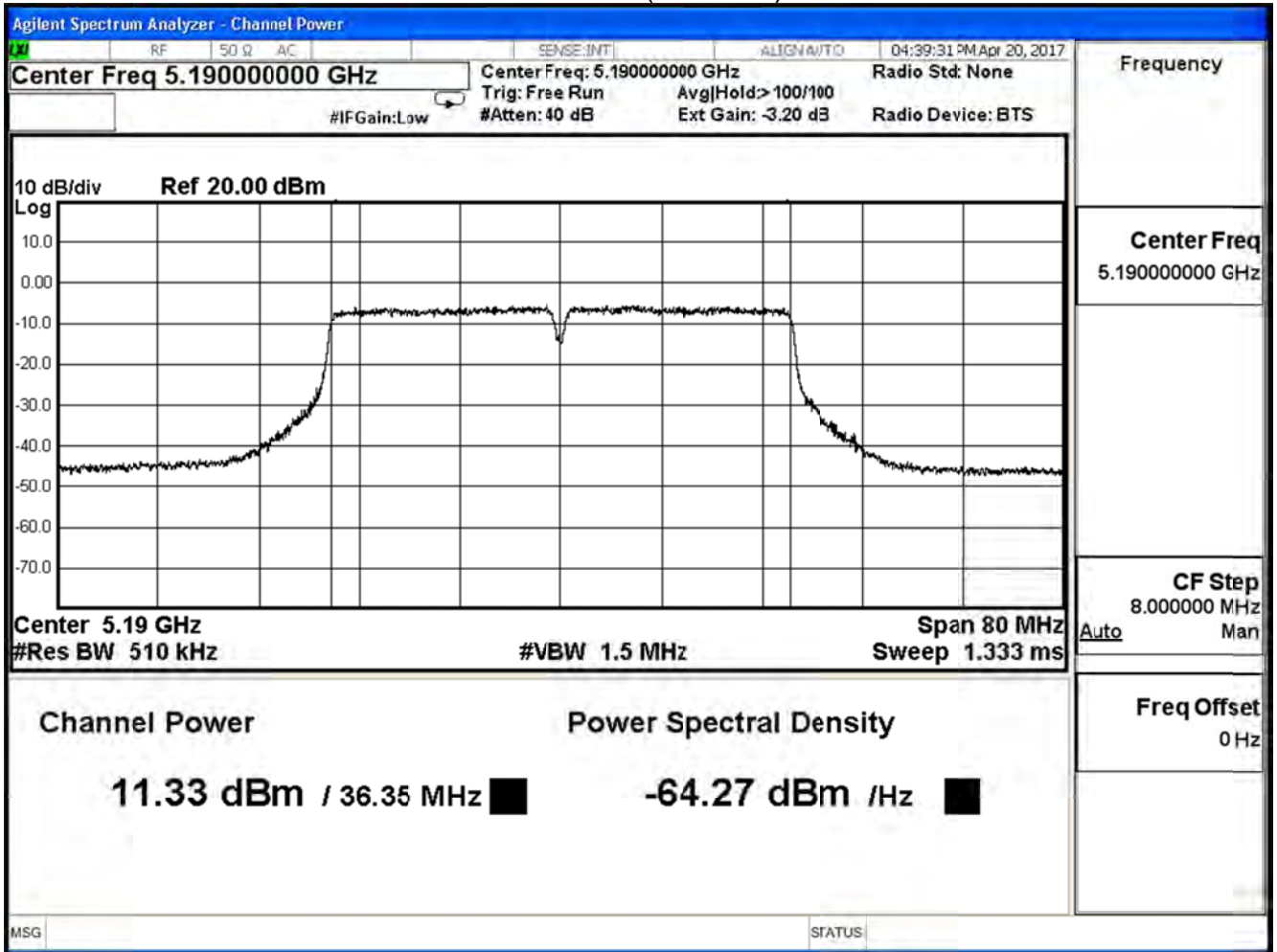

Channel 46 (5230MHz)

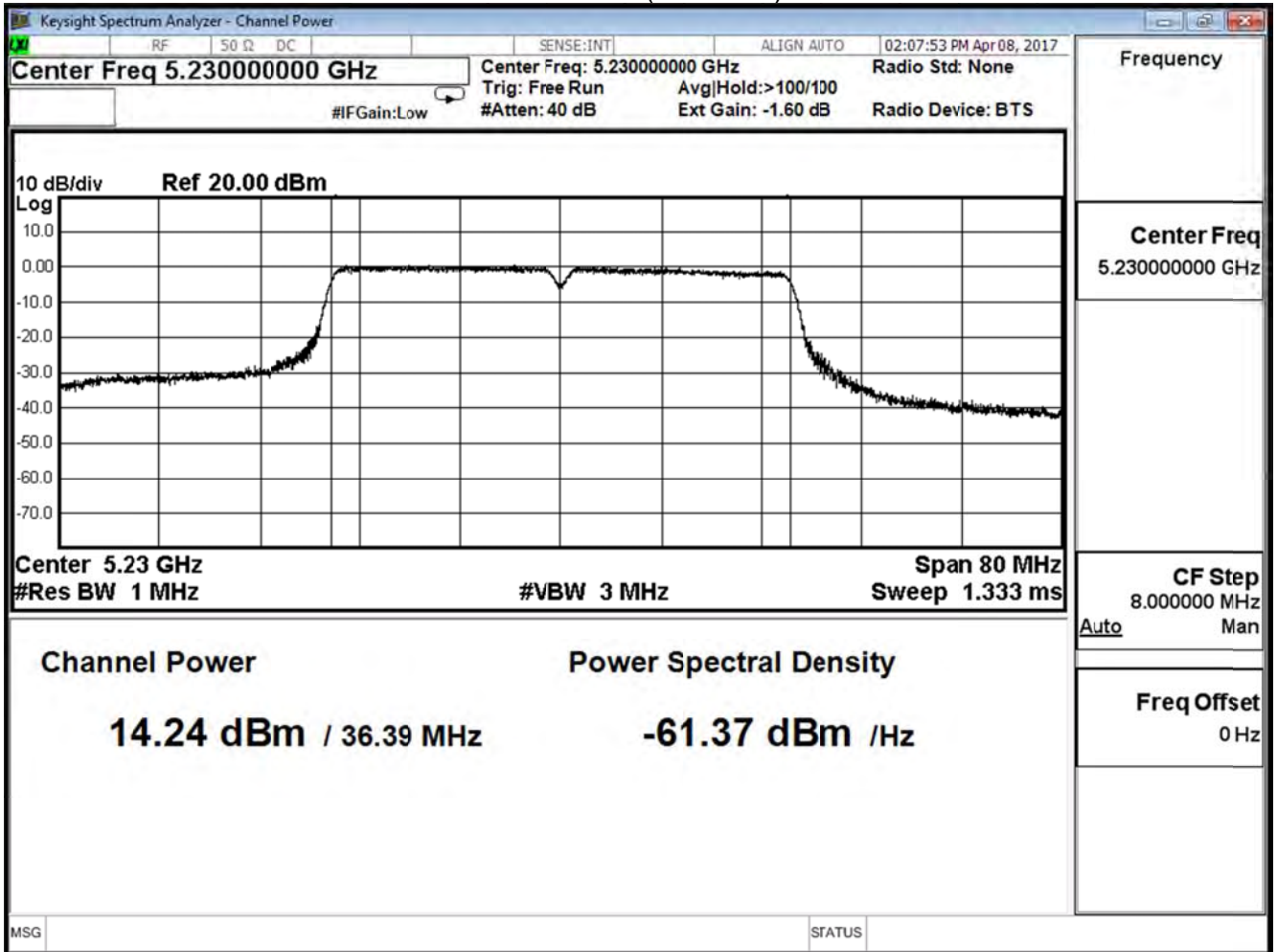

Product	Lyra		
Test Item	Peak Transmit power		
Test Mode	Mode 2: Tx-AD2055320 BF Mode		
Date of Test	2017/04/08	Test Site	SR10-H

IEEE 802.11n40 (ANT 0+1)			
Channel No.	Frequency (MHz)	Measure Level (dBm)	Limit (dBm)
38	5190	14.227	≤ 28.68
46	5230	17.041	≤ 28.68

Product	Lyra		
Test Item	Peak Transmit power		
Test Mode	Mode 2: Tx-AD2055320 BF Mode		
Date of Test	2017/04/08	Test Site	SR10-H

IEEE 802.11ac80 (ANT 0)			
Channel No.	Frequency (MHz)	Measure Level (dBm)	Limit (dBm)
42	5210	7.310	≤ 28.68

Peak Power Output (dBm)												
MCS Index												Require Limit
Channel No	Frequency (MHz)	Data Rate										
		0	1	2	3	4	5	6	7	8	9	
42	5210	7.310	7.160	7.030	6.900	6.760	6.620	6.480	6.340	6.200	6.060	≤ 28.68

Note:

Directional Antenna=10log(N)+Max Gain=3.01+4.31dBi=7.32dBi

Required Limit=30dBm-(7.32dBi-6dB)=28.68dBm

Channel 42 (5210MHz)

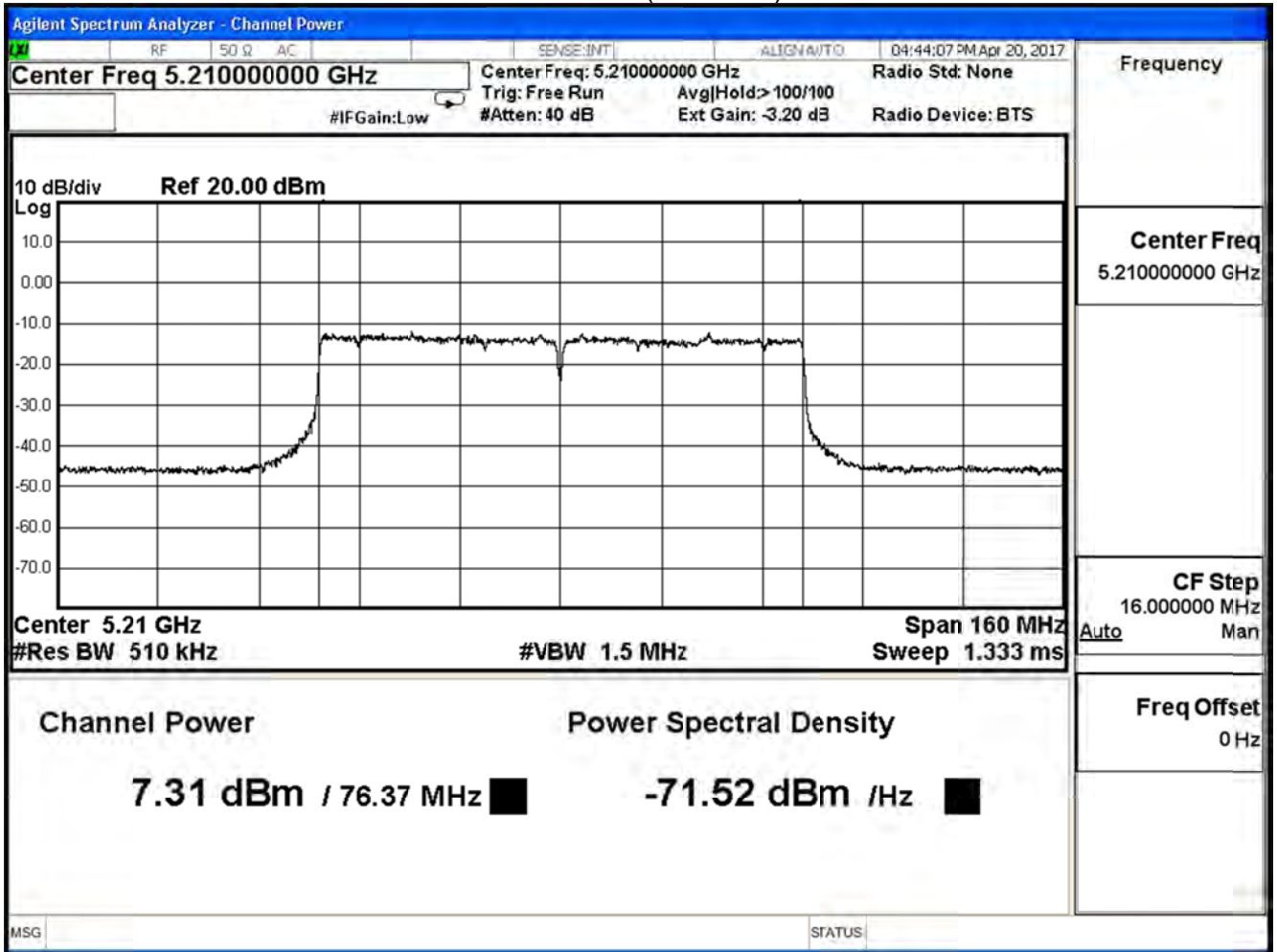

Product	Lyra		
Test Item	Peak Transmit power		
Test Mode	Mode 2: Tx-AD2055320 BF Mode		
Date of Test	2017/04/08	Test Site	SR10-H

IEEE 802.11ac80 (ANT 1)			
Channel No.	Frequency (MHz)	Measure Level (dBm)	Limit (dBm)
42	5210	8.570	≤ 28.68

Peak Power Output (dBm)												
MCS Index												Require Limit
Channel No	Frequency (MHz)	Data Rate										
		0	1	2	3	4	5	6	7	8	9	
42	5210	8.570	8.440	8.300	8.160	8.020	7.880	7.740	7.600	7.470	7.330	≤ 28.68

Note:

Directional Antenna=10log(N)+Max Gain=3.01+4.31dBi=7.32dBi

Required Limit=30dBm-(7.32dBi-6dB)=28.68dBm

Channel 42 (5210MHz)

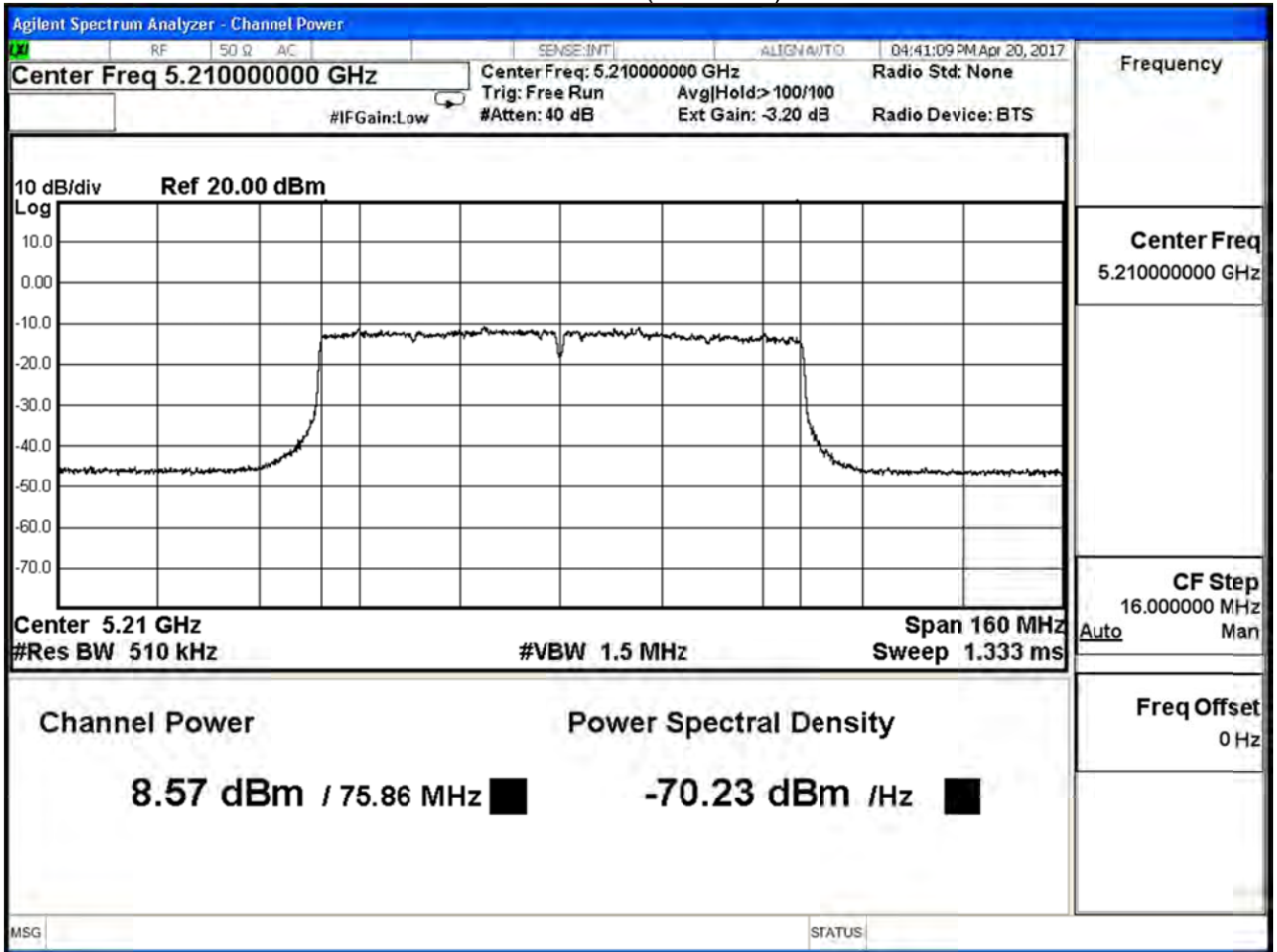

Product	Lyra		
Test Item	Peak Transmit power		
Test Mode	Mode 2: Tx-AD2055320 BF Mode		
Date of Test	2017/04/08	Test Site	SR10-H

IEEE 802.11ac80 (ANT 0+1)			
Channel No.	Frequency (MHz)	Measure Level (dBm)	Limit (dBm)
42	5210	10.996	≤ 28.68

Product	Lyra		
Test Item	Peak Transmit Output		
Test Mode	Mode 1: Tx-AD2055320 Mode		
Date of Test	2017/04/08	Test Site	SR10-H

IEEE 802.11a (ANT 0)			
Channel No.	Frequency (MHz)	Measure Level (dBm)	Limit (dBm)
149	5745	20.780	≤ 30
157	5785	21.520	≤ 30
165	5825	21.670	≤ 30

The worst emission of data rate is 6 Mbps.

Peak Power Output (dBm)									
Channel No	Frequency (MHz)	Data Rate							Required Limit
		6	12	18	24	36	48	54	
149	5745	20.780	--	--	--	--	--	--	≤ 30
157	5785	21.520	21.380	21.250	21.100	20.970	20.820	20.690	≤ 30
165	5825	21.670	--	--	--	--	--	--	≤ 30

Channel 149 (5745MHz)

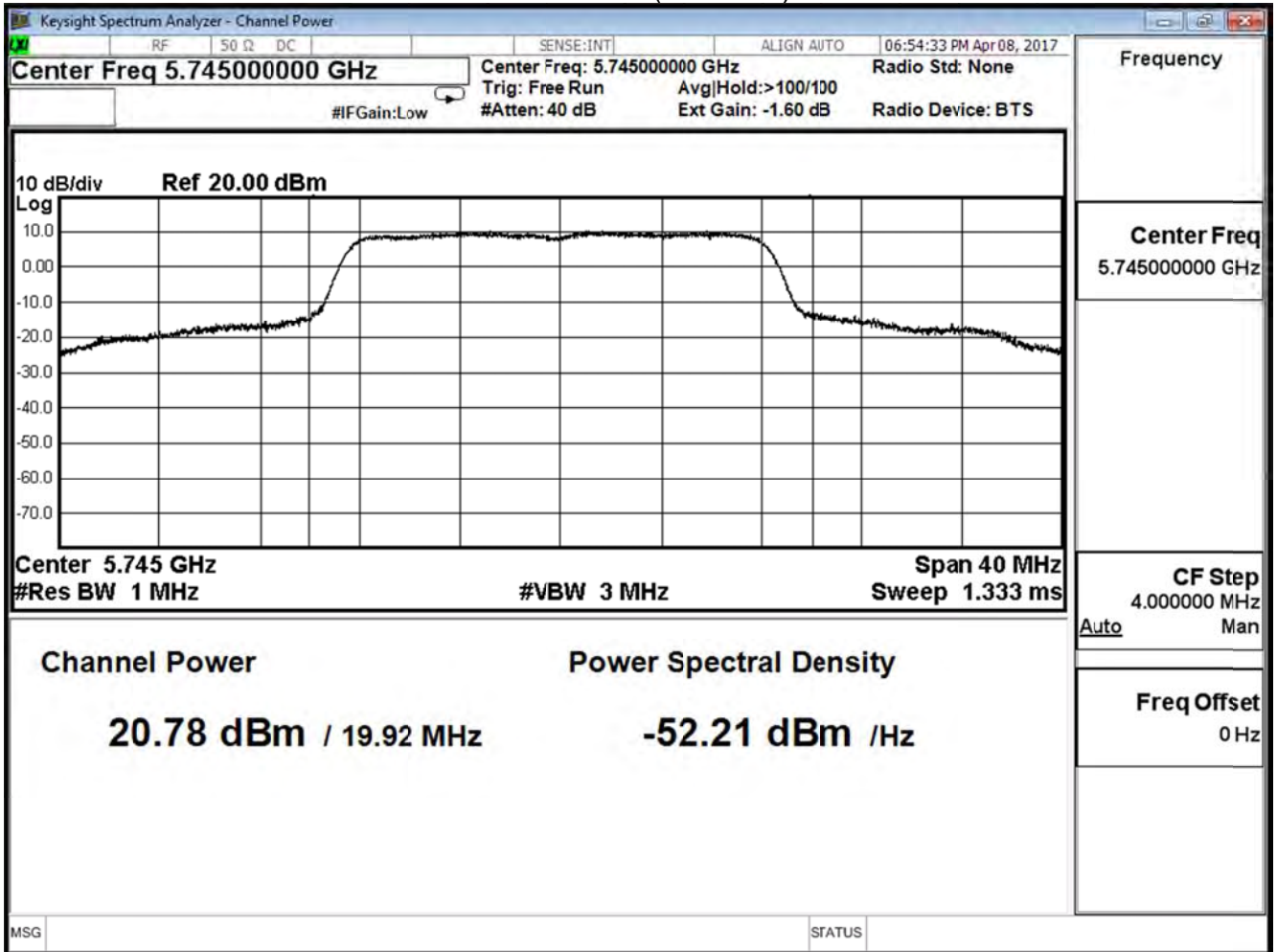

Channel 157 (5785MHz)

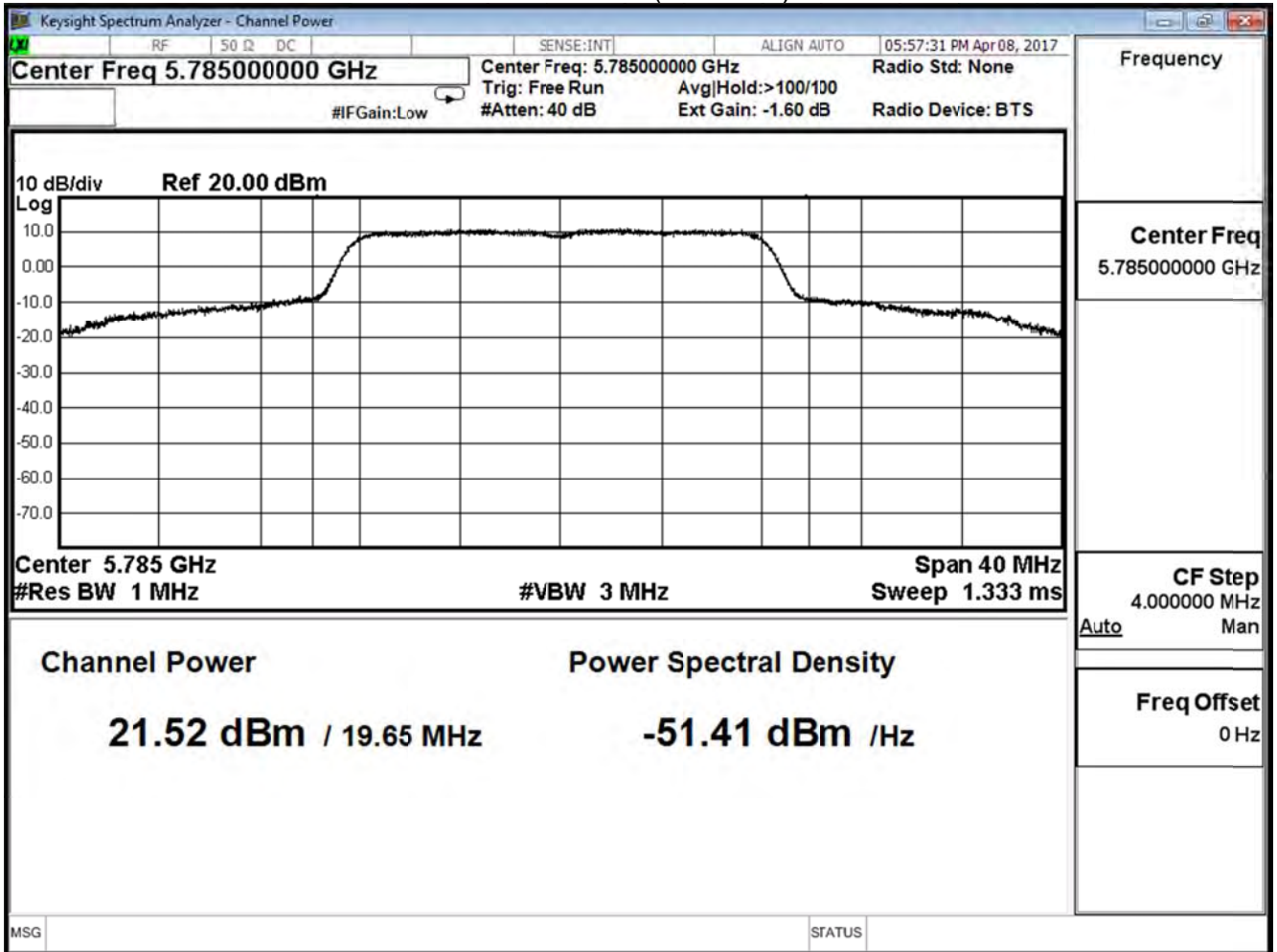

Channel 165 (5825MHz)

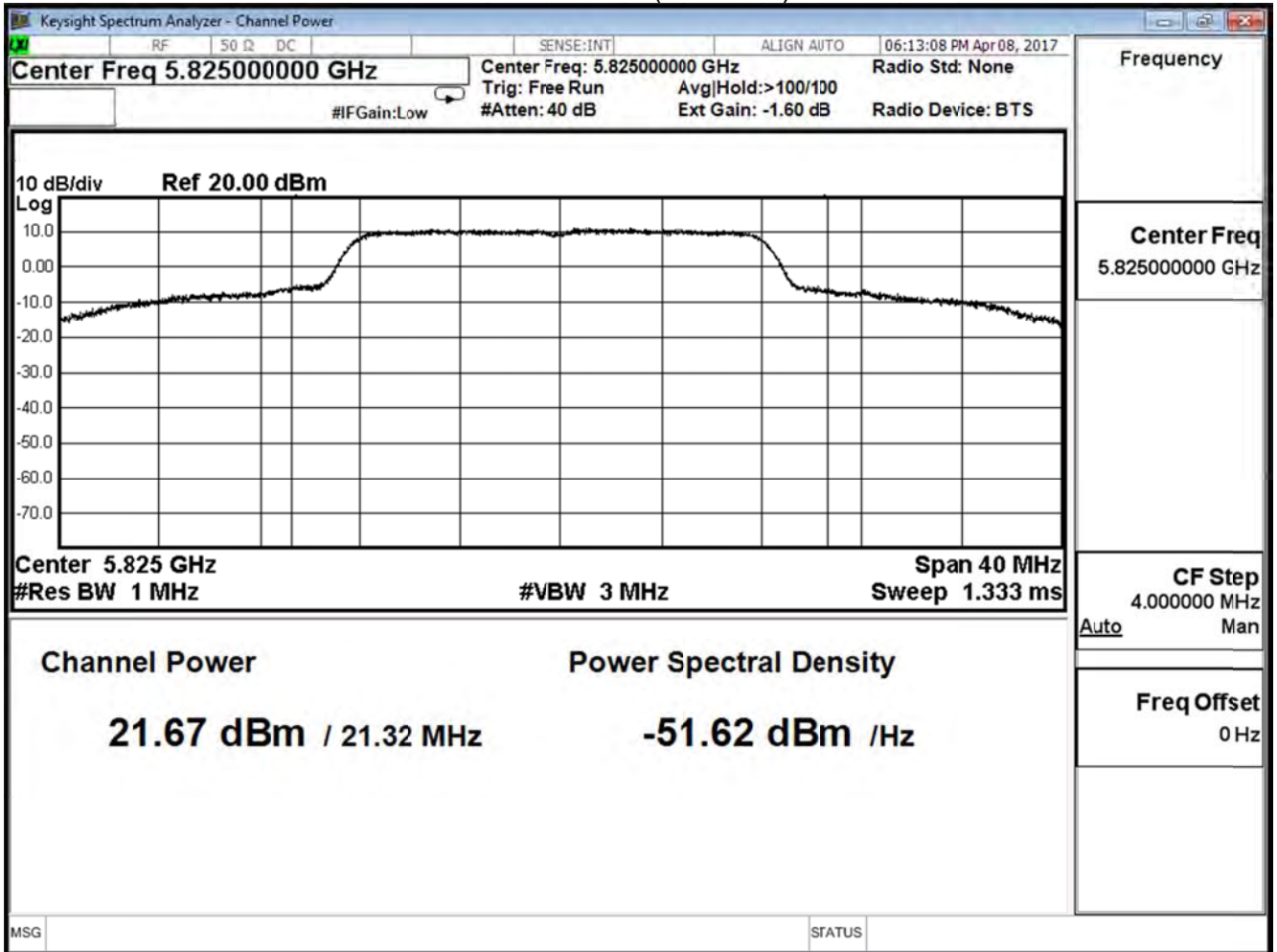

Product	Lyra		
Test Item	Peak Transmit Output		
Test Mode	Mode 1: Tx-AD2055320 Mode		
Date of Test	2017/04/08	Test Site	SR10-H

IEEE 802.11a (ANT 1)			
Channel No.	Frequency (MHz)	Measure Level (dBm)	Limit (dBm)
149	5745	20.400	≤ 30
157	5785	21.630	≤ 30
165	5825	21.730	≤ 30

The worst emission of data rate is 6 Mbps.

Peak Power Output (dBm)									
Channel No	Frequency (MHz)	Data Rate							Required Limit
		6	12	18	24	36	48	54	
149	5745	20.400	--	--	--	--	--	--	≤ 30
157	5785	21.630	21.480	21.340	21.200	21.060	20.910	20.760	≤ 30
165	5825	21.730	--	--	--	--	--	--	≤ 30

Channel 149 (51745MHz)

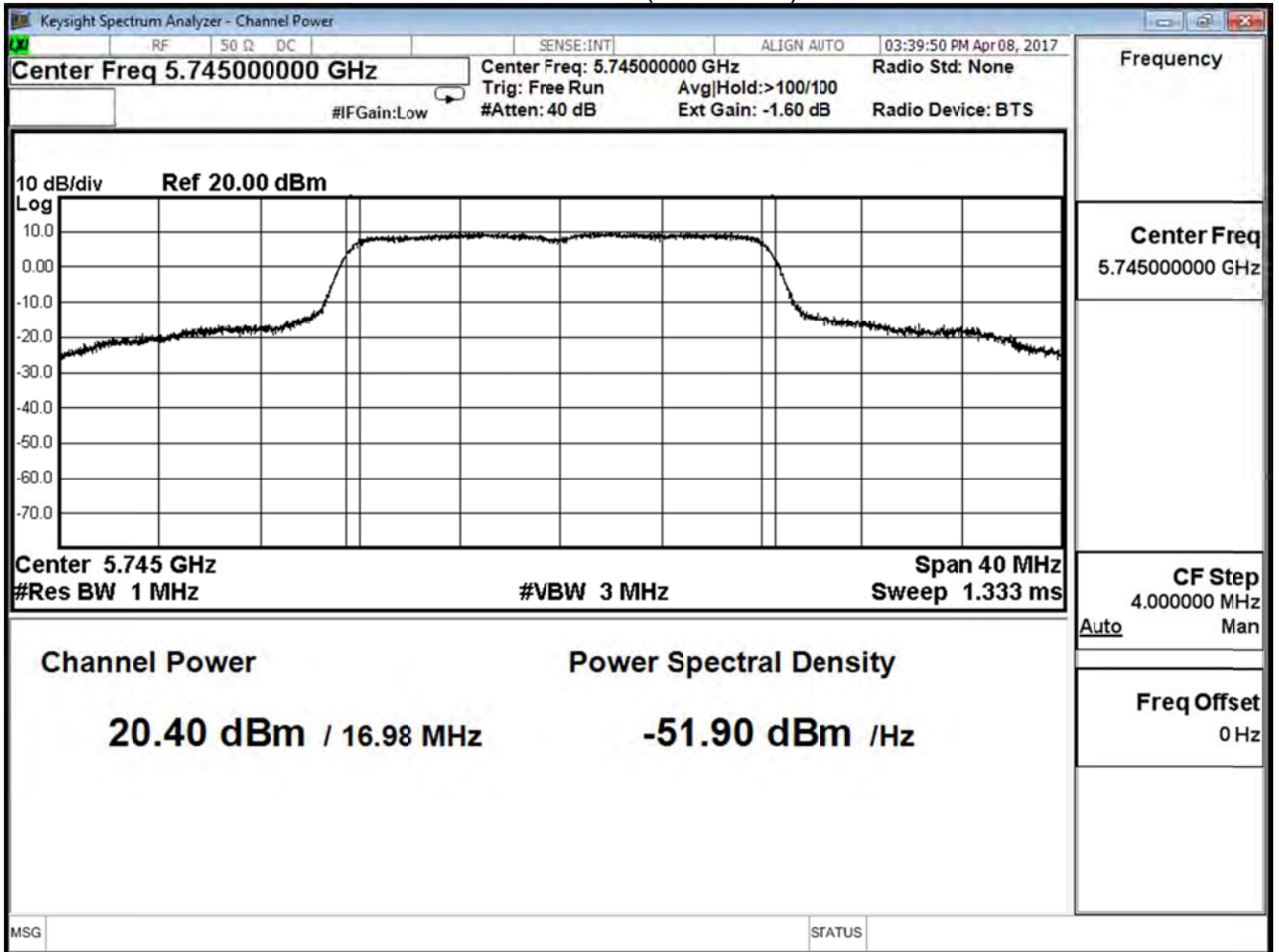

Channel 157 (5785MHz)

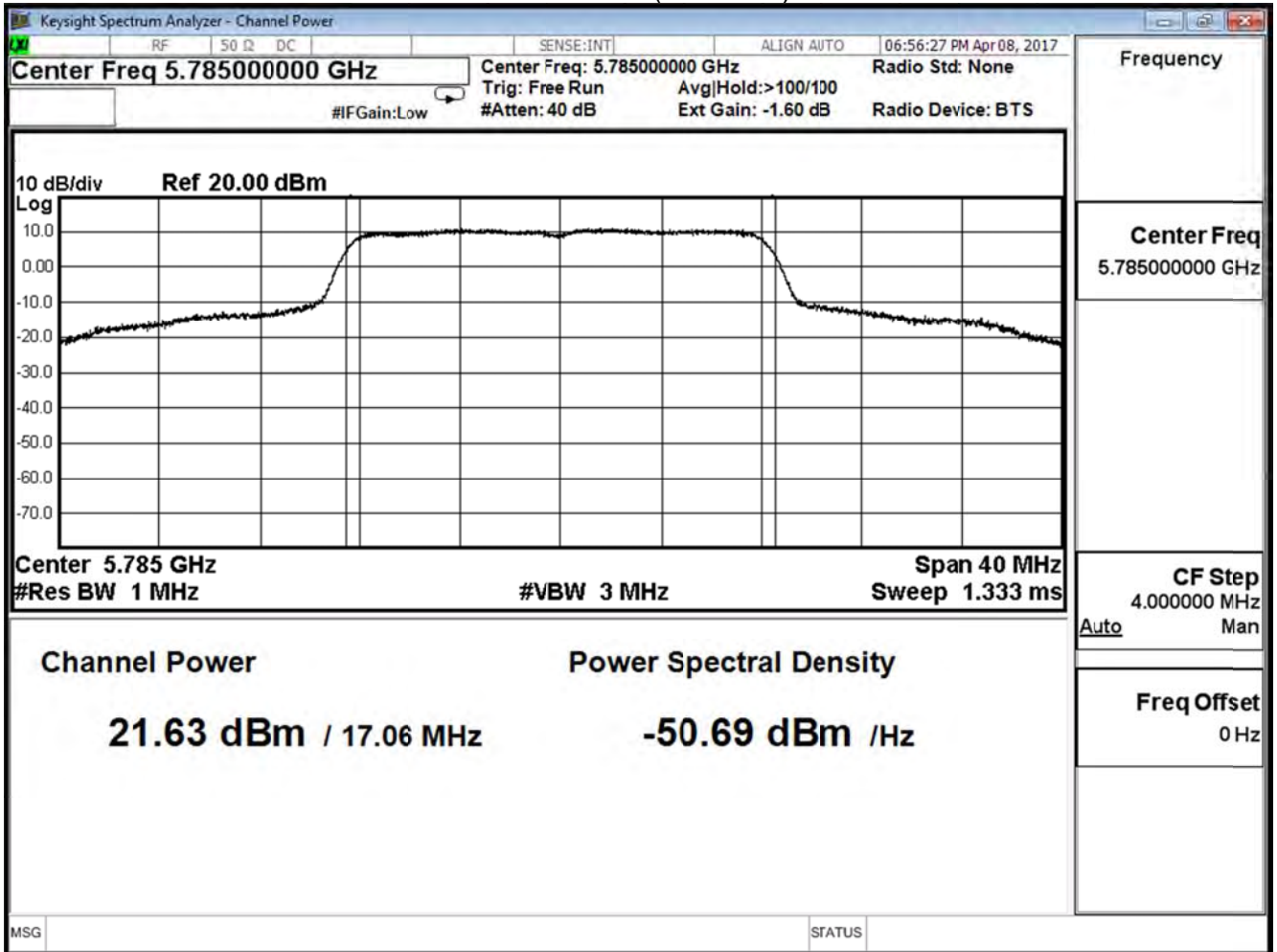

Channel 165 (5825MHz)

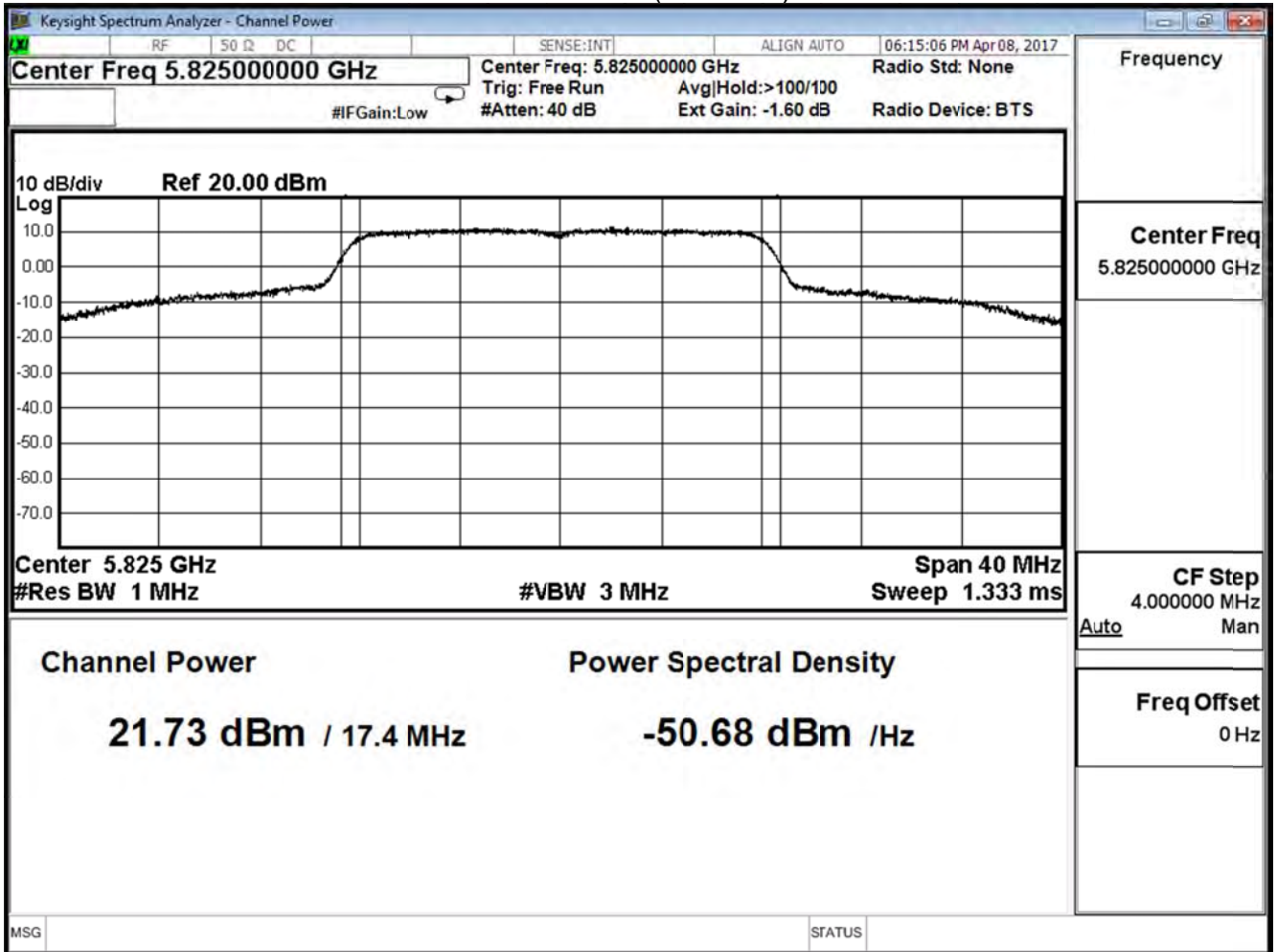

Product	Lyra		
Test Item	Peak Transmit Output		
Test Mode	Mode 1: Tx-AD2055320 Mode		
Date of Test	2017/04/08	Test Site	SR10-H

IEEE 802.11a (ANT 0+1)			
Channel No.	Frequency (MHz)	Measure Level (dBm)	Limit (dBm)
149	5745	23.604	≤ 30
157	5785	24.586	≤ 30
165	5825	24.710	≤ 30

Product	Lyra		
Test Item	Peak Transmit power		
Test Mode	Mode 1: Tx-AD2055320 Mode		
Date of Test	2017/04/08	Test Site	SR10-H

IEEE 802.11n20 (ANT 0)			
Channel No.	Frequency (MHz)	Measure Level (dBm)	Limit (dBm)
149	5745	21.060	≤ 30
157	5785	21.610	≤ 30
165	5825	21.790	≤ 30

The worst emission of data rate is MCS8

Peak Power Output (dBm)										
Channel No	Frequency (MHz)	Data Rate								Required Limit
		8	9	10	11	12	13	14	15	
149	5745	21.060	--	--	--	--	--	--	--	≤ 30
157	5785	21.610	21.550	21.320	21.180	21.020	20.940	20.720	20.550	≤ 30
165	5825	21.790	--	--	--	--	--	--	--	≤ 30

Channel 149 (5745MHz)

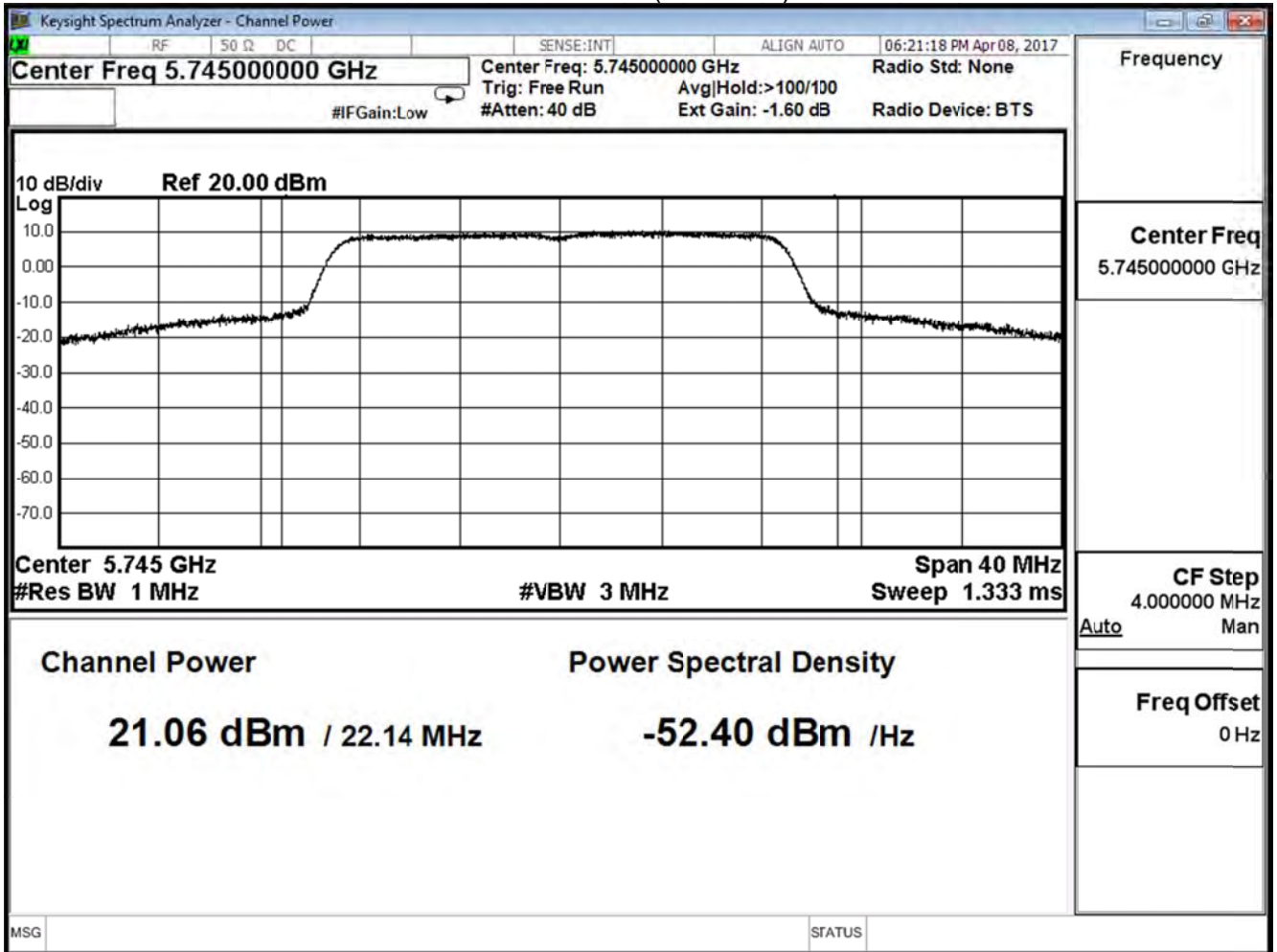

Channel 157 (5785MHz)

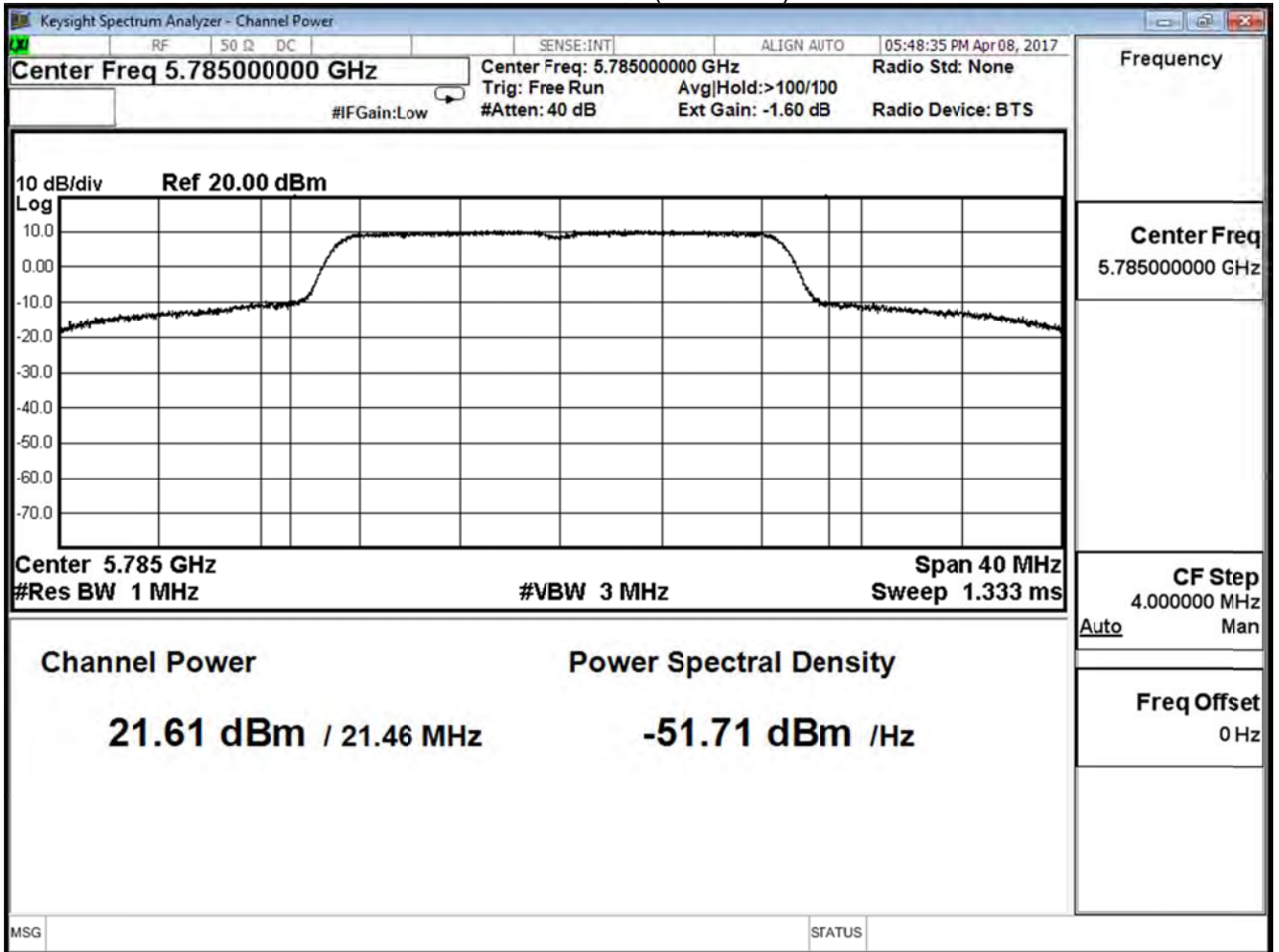

Channel 165 (5825MHz)

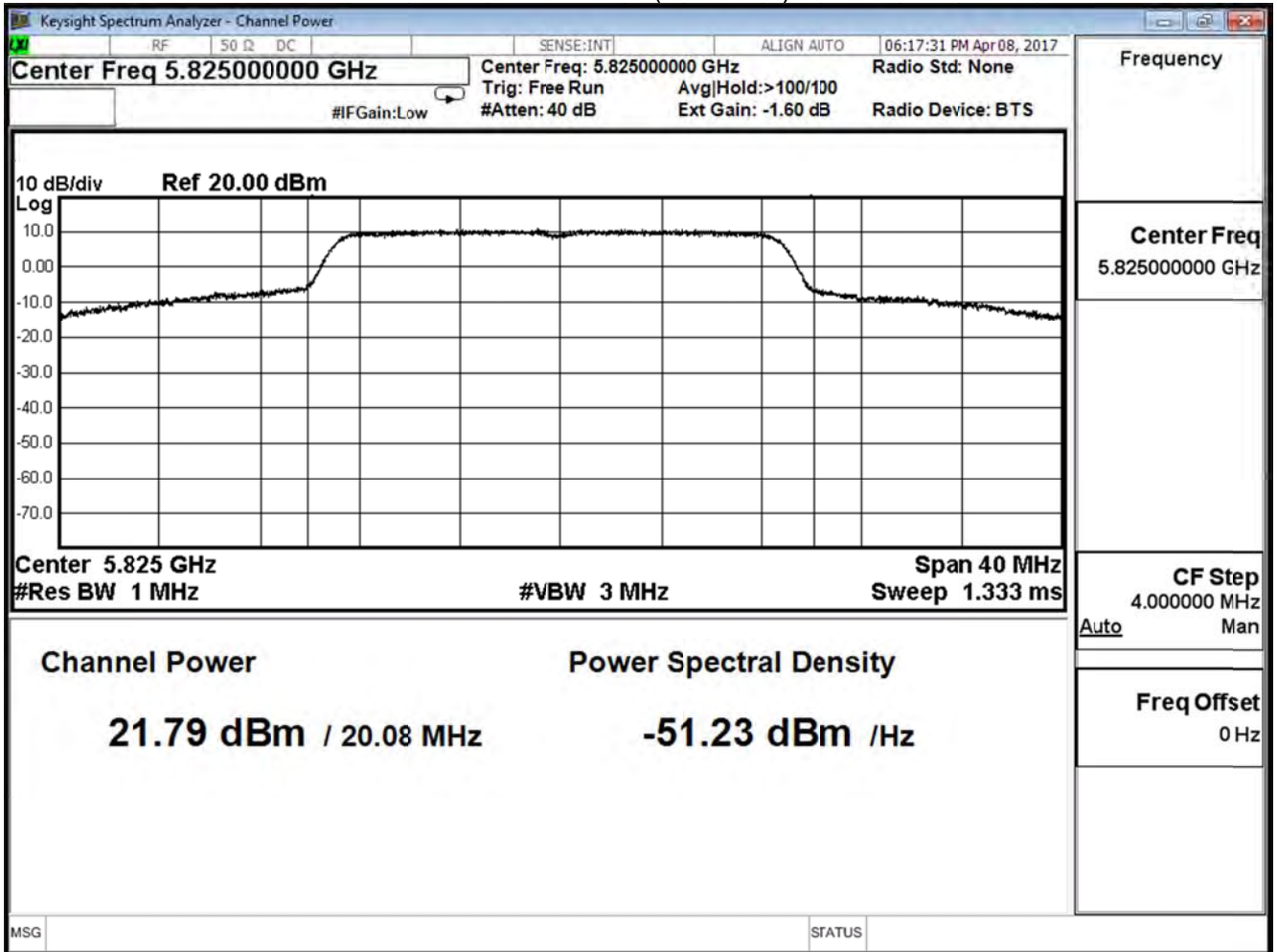

Product	Lyra		
Test Item	Peak Transmit power		
Test Mode	Mode 1: Tx-AD2055320 Mode		
Date of Test	2017/04/12	Test Site	SR10-H

IEEE 802.11n20 (ANT 1)			
Channel No.	Frequency (MHz)	Measure Level (dBm)	Limit (dBm)
149	5745	20.950	≤ 30
157	5785	21.410	≤ 30
165	5825	21.760	≤ 30

Peak Power Output (dBm)										
MCS Index										Required Limit
Channel No	Frequency (MHz)	Data Rate								
		8	9	10	11	12	13	14	15	
149	5745	20.950	--	--	--	--	--	--	--	≤ 30
157	5785	21.410	21.320	21.240	21.150	21.040	20.930	20.780	20.610	≤ 30
165	5825	21.760	--	--	--	--	--	--	--	≤ 30

Channel 149 (5745MHz)

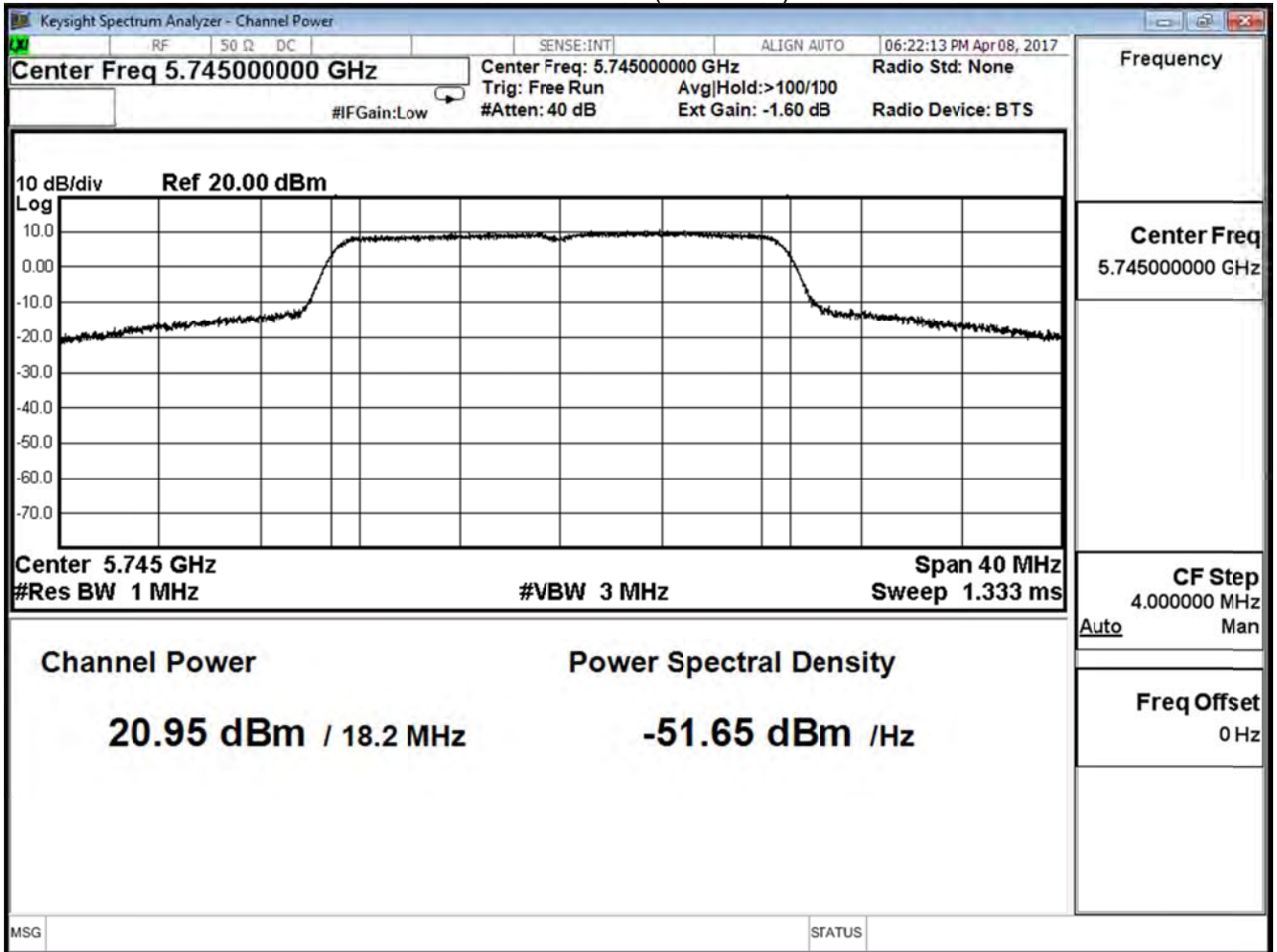

Channel 157 (5785MHz)

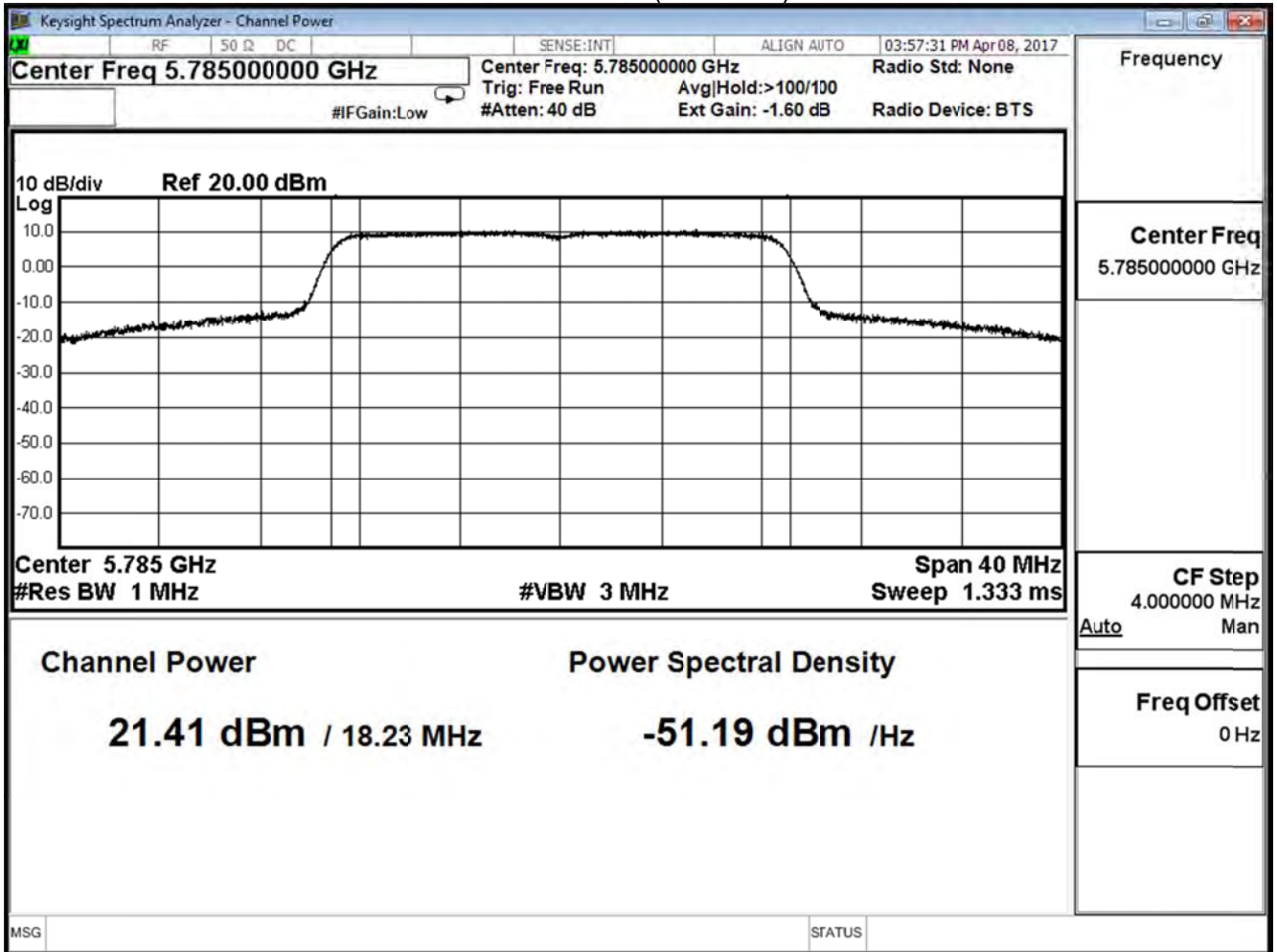

Channel 165 (5825MHz)

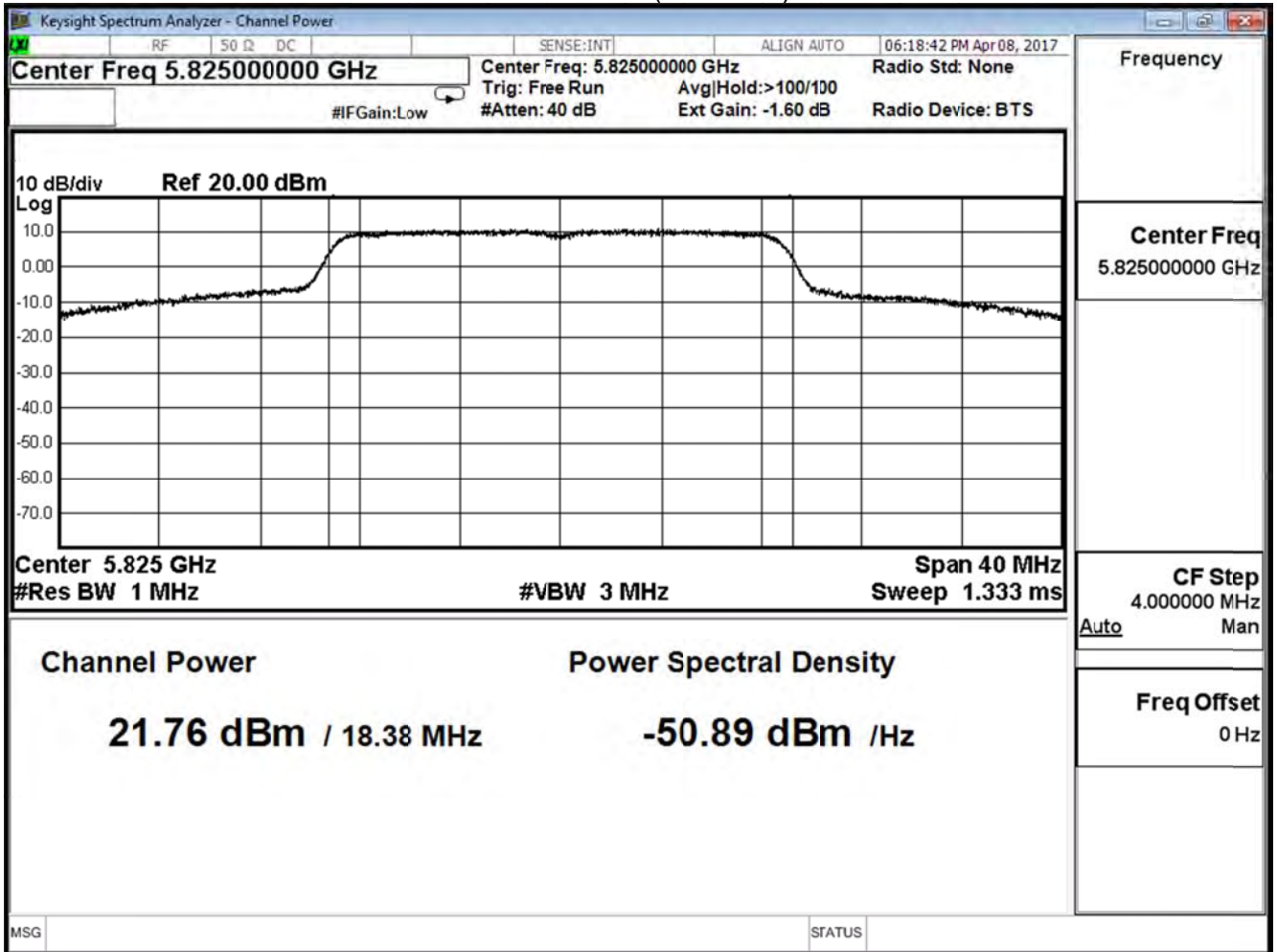

Product	Lyra		
Test Item	Peak Transmit power		
Test Mode	Mode 1: Tx-AD2055320 Mode		
Date of Test	2017/04/12	Test Site	SR10-H

IEEE 802.11n20 (ANT 0+1)			
Channel No.	Frequency (MHz)	Measure Level (dBm)	Limit (dBm)
149	5745	24.016	≤ 30
157	5785	24.521	≤ 30
165	5825	24.785	≤ 30

Product	Lyra		
Test Item	Peak Transmit power		
Test Mode	Mode 1: Tx-AD2055320 Mode		
Date of Test	2017/04/12	Test Site	SR10-H

IEEE 802.11n40 (ANT 0)			
Channel No.	Frequency (MHz)	Measure Level (dBm)	Limit (dBm)
151	5755	20.710	≤ 30
159	5795	22.200	≤ 30

Peak Power Output (dBm)										
MCS Index										Required Limit
Channel No	Frequency (MHz)	Data Rate								
		8	9	10	11	12	13	14	15	
151	5755	20.710	--	--	--	--	--	--	--	≤ 30
159	5795	22.200	22.050	21.910	21.760	21.620	21.470	21.330	21.190	≤ 30

Channel 151 (5755MHz)

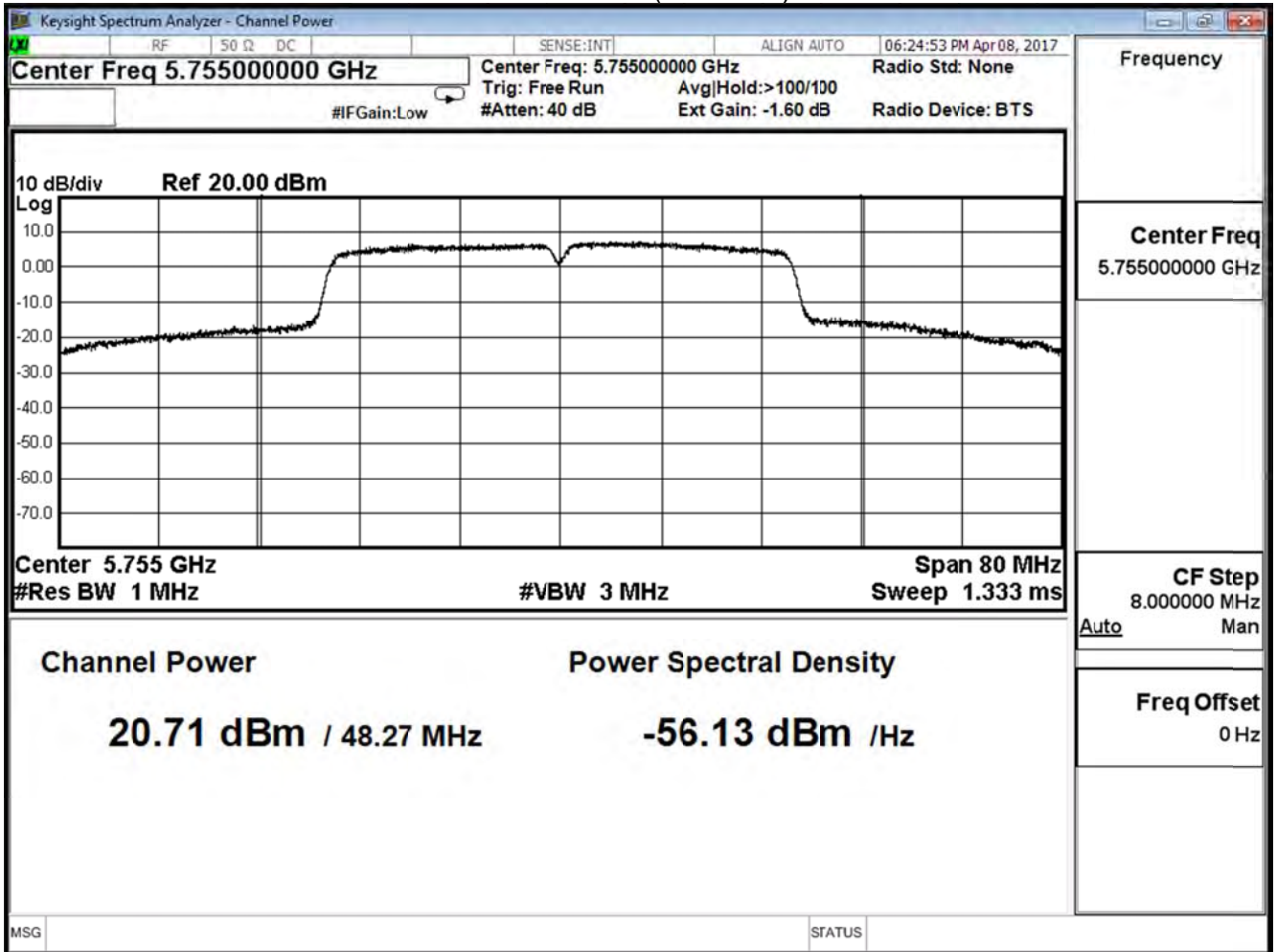

Channel 159 (5795MHz)

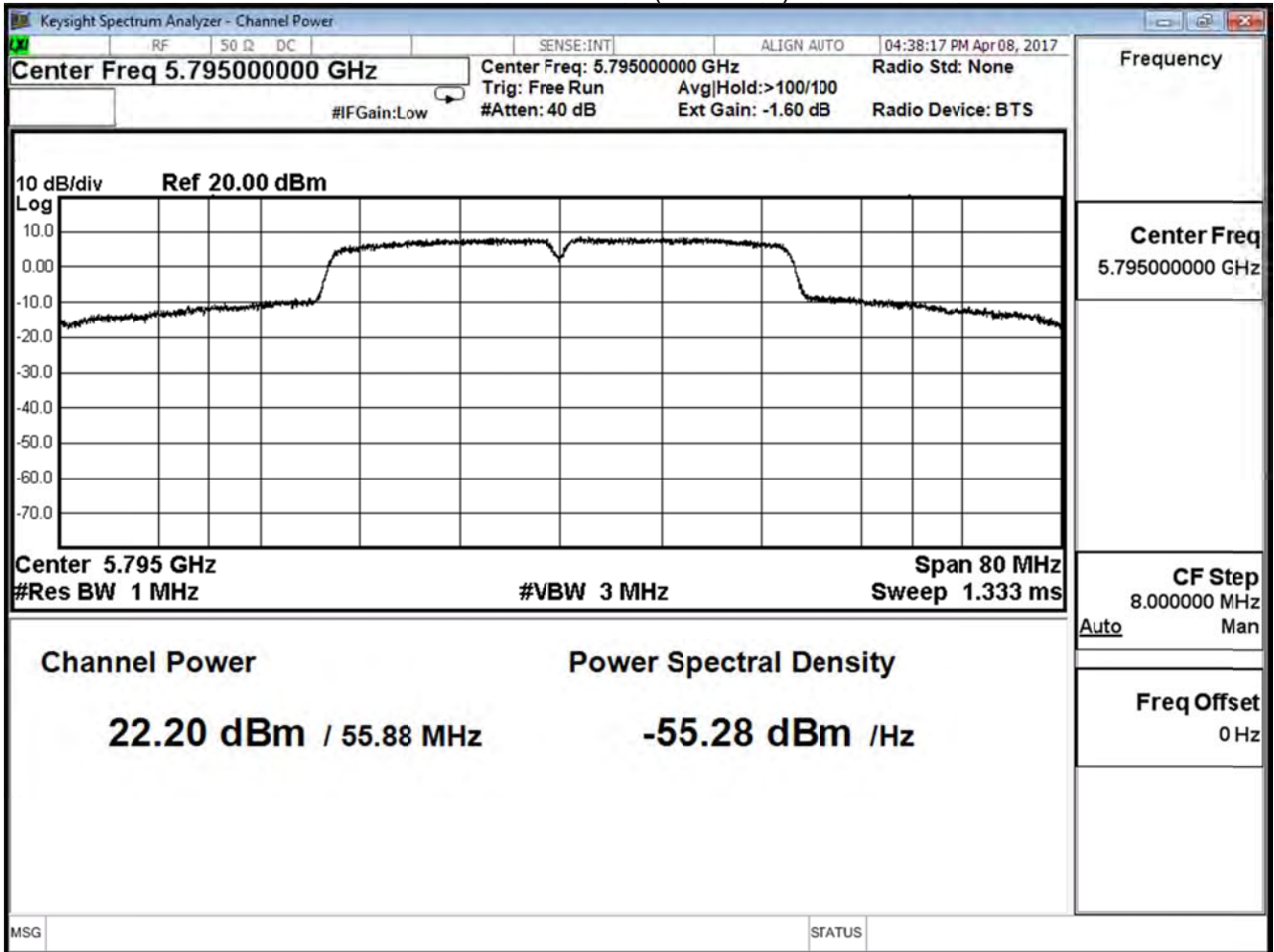

Product	Lyra		
Test Item	Peak Transmit power		
Test Mode	Mode 1: Tx-AD2055320 Mode		
Date of Test	2017/04/12	Test Site	SR10-H

IEEE 802.11n40 (ANT 1)			
Channel No.	Frequency (MHz)	Measure Level (dBm)	Limit (dBm)
151	5755	20.680	≤ 30
159	5795	21.830	≤ 30

Peak Power Output (dBm)										
		MCS Index								Required Limit
Channel No	Frequency (MHz)	Data Rate								
		8	9	10	11	12	13	14	15	
151	5755	20.680	--	--	--	--	--	--	--	≤ 30
159	5795	21.830	21.700	21.570	21.420	21.270	21.130	20.990	20.850	≤ 30

Channel 151 (5755MHz)

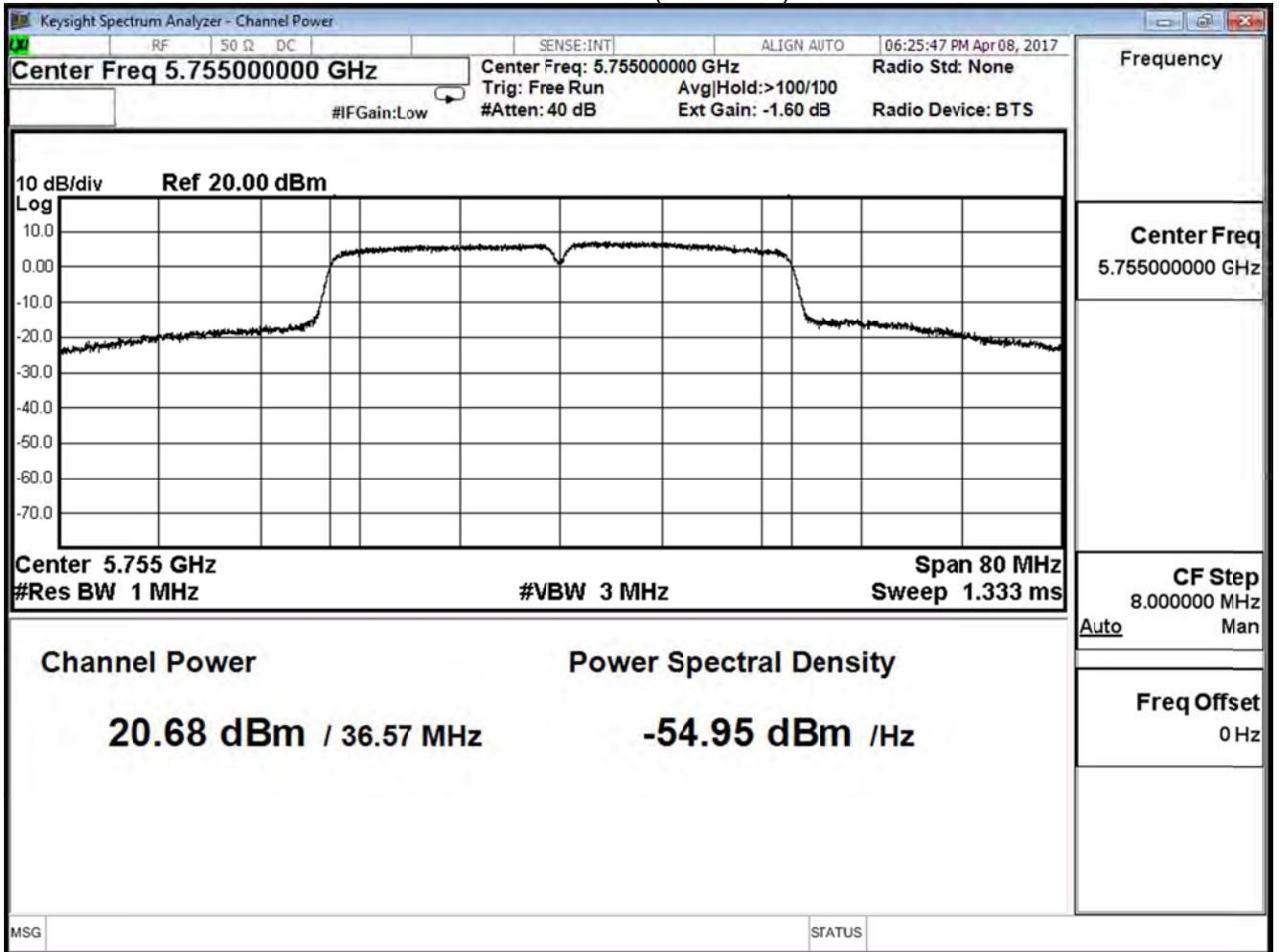

Channel 159 (5795MHz)

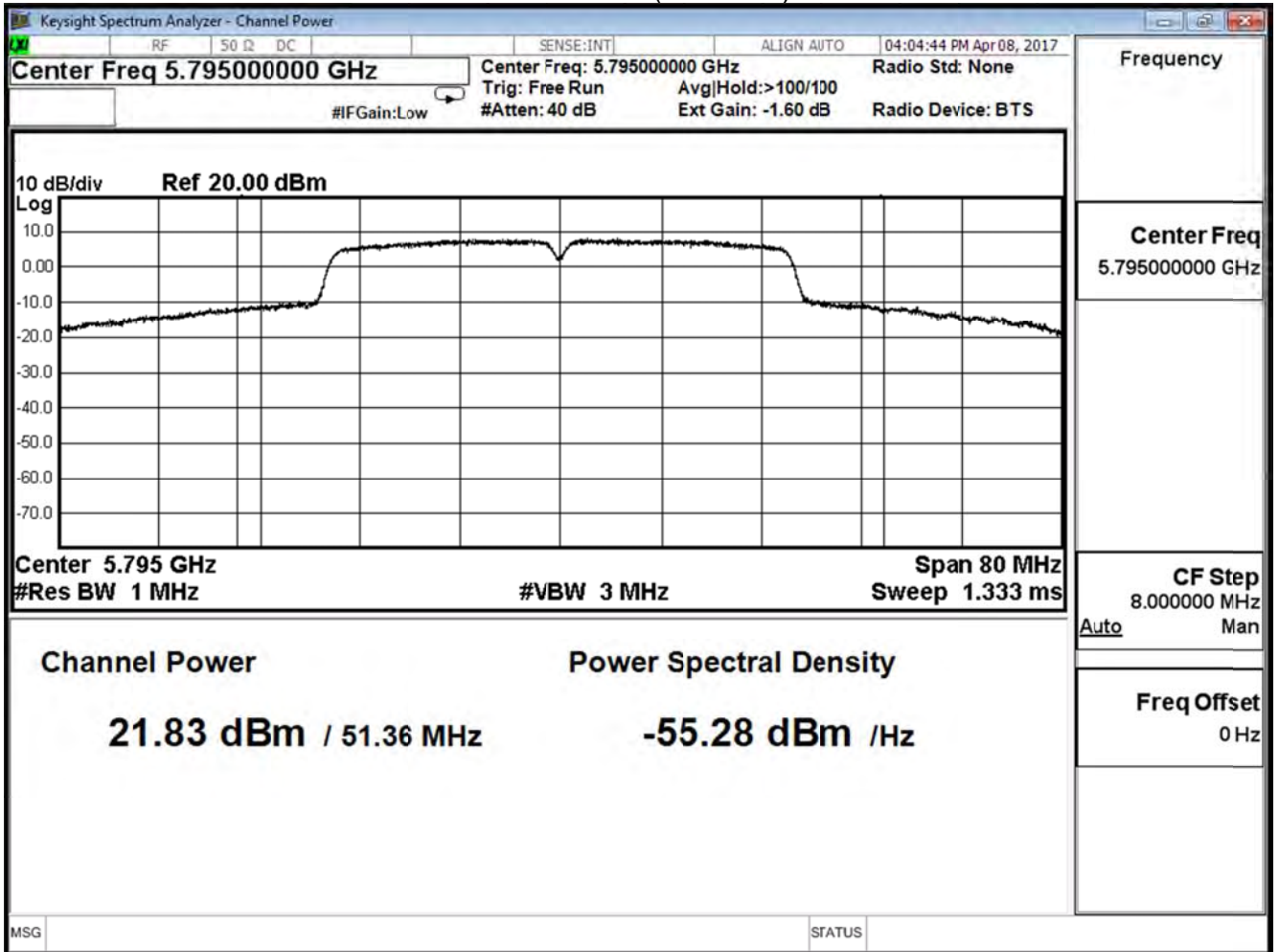

Product	Lyra		
Test Item	Peak Transmit power		
Test Mode	Mode 1: Tx-AD2055320 Mode		
Date of Test	2017/04/12	Test Site	SR10-H

IEEE 802.11n40 (ANT 0+1)			
Channel No.	Frequency (MHz)	Measure Level (dBm)	Limit (dBm)
151	5755	23.705	≤ 30
159	5795	25.029	≤ 30

Product	Lyra		
Test Item	Peak Transmit power		
Test Mode	Mode 1: Tx-AD2055320 Mode		
Date of Test	2017/04/12	Test Site	SR10-H

IEEE 802.11ac80 (ANT 0)			
Channel No.	Frequency (MHz)	Measure Level (dBm)	Limit (dBm)
155	5775	16.820	≤ 30

Peak Power Output (dBm)												
MCS Index												Require Limit
Channel No	Frequency (MHz)	Data Rate										
		0	1	2	3	4	5	6	7	8	9	
155	5775	16.820	16.680	16.530	16.390	16.250	16.110	15.970	15.830	15.690	15.540	≤ 30

Channel 155 (5775MHz)

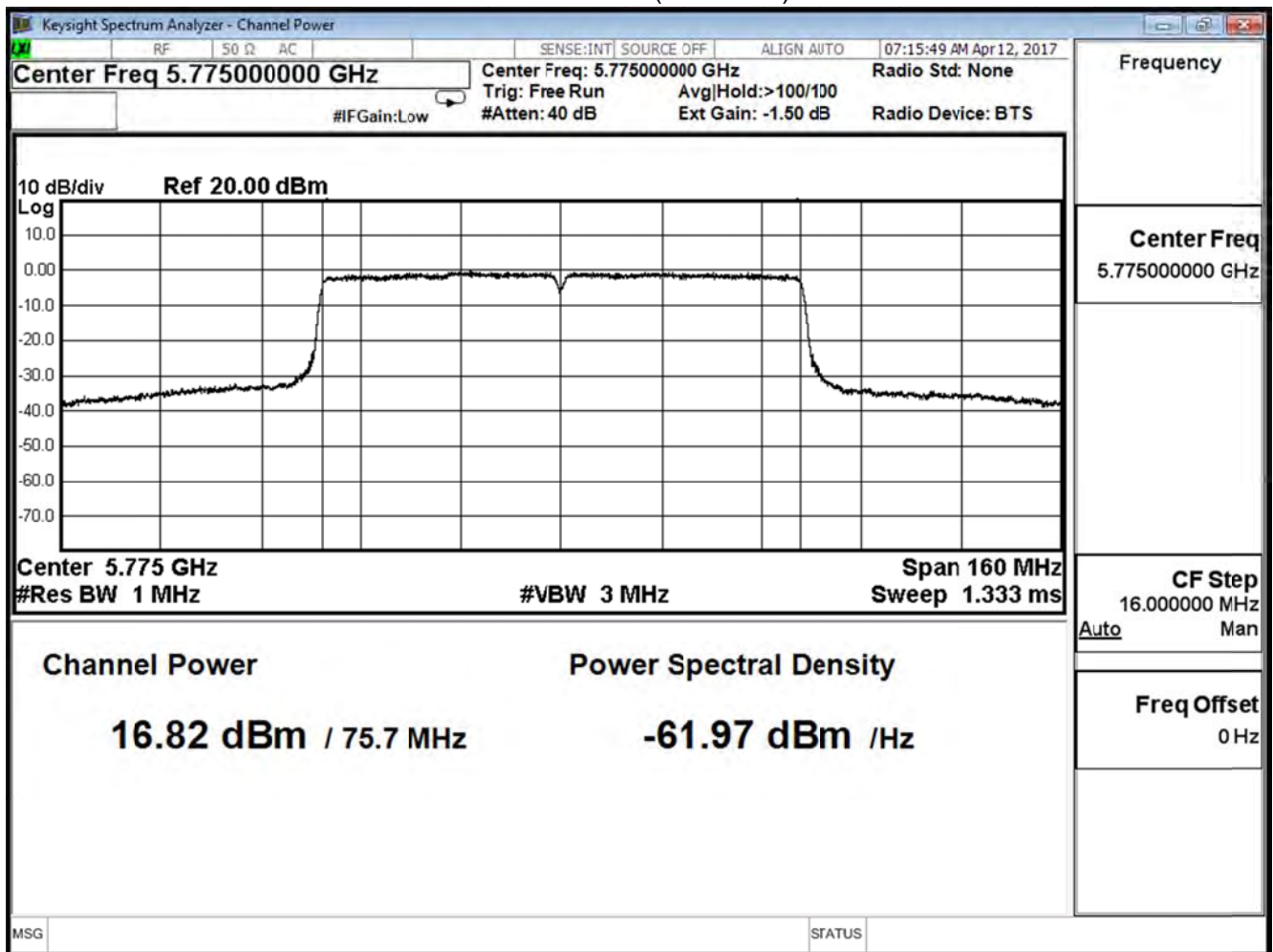

Product	Lyra		
Test Item	Peak Transmit power		
Test Mode	Mode 1: Tx-AD2055320 Mode		
Date of Test	2017/04/12	Test Site	SR10-H

IEEE 802.11ac80 (ANT 1)			
Channel No.	Frequency (MHz)	Measure Level (dBm)	Limit (dBm)
155	5775	16.950	≤ 30

Peak Power Output (dBm)												
MCS Index												Require Limit
Channel No	Frequency (MHz)	Data Rate										≤ 30
		0	1	2	3	4	5	6	7	8	9	
155	5775	16.950	16.800	16.660	16.520	16.380	16.240	16.100	15.970	15.820	15.670	

Channel 155 (5775MHz)

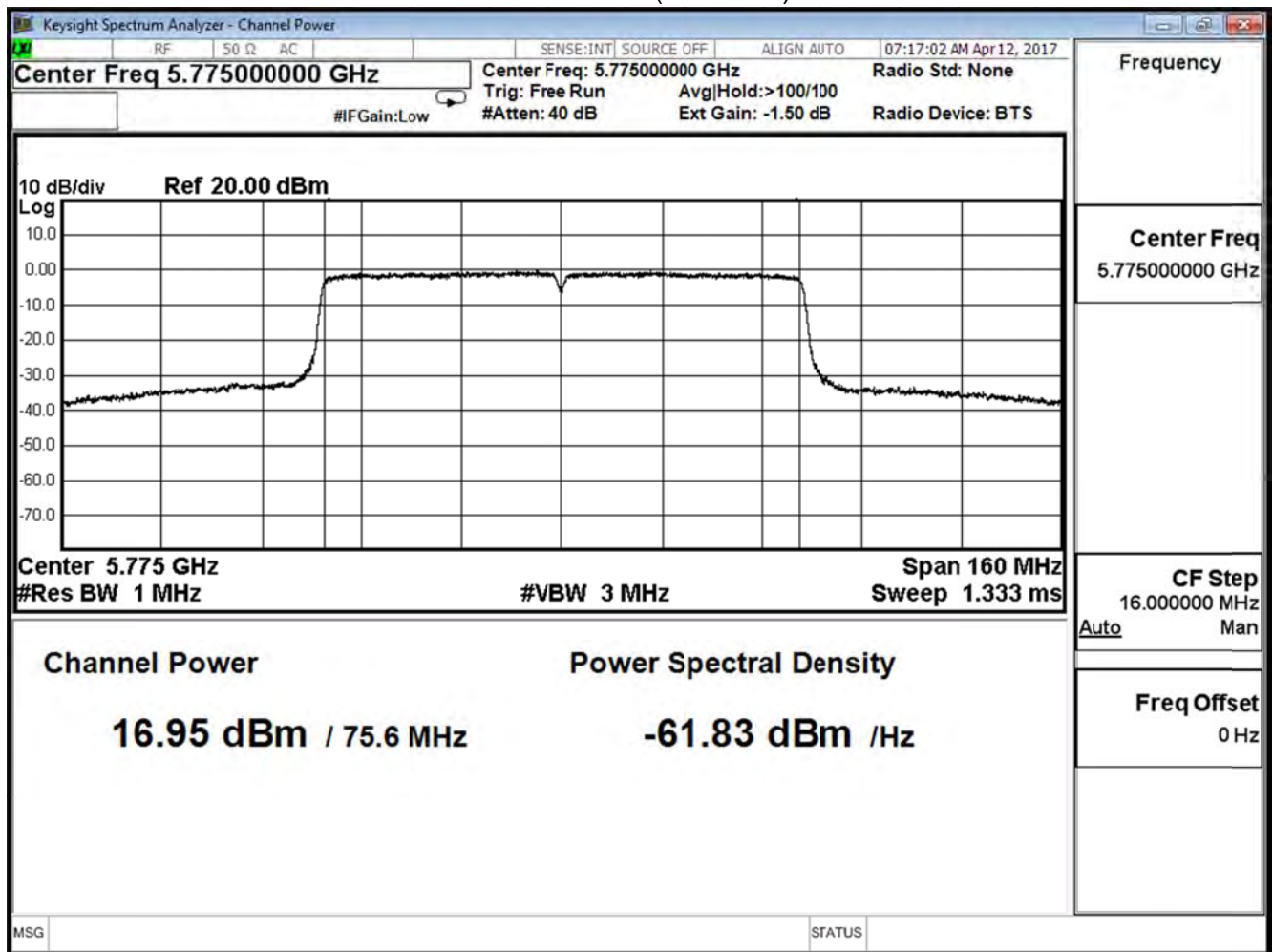

Product	Lyra		
Test Item	Peak Transmit power		
Test Mode	Mode 1: Tx-AD2055320 Mode		
Date of Test	2017/04/12	Test Site	SR10-H

IEEE 802.11ac80 (ANT 0+1)			
Channel No.	Frequency (MHz)	Measure Level (dBm)	Limit (dBm)
155	5775	19.896	≤ 30

Product	Lyra		
Test Item	Peak Transmit power		
Test Mode	Mode 2: Tx-AD2055320 BF Mode		
Date of Test	2017/04/12	Test Site	SR10-H

IEEE 802.11n20 (ANT 0)			
Channel No.	Frequency (MHz)	Measure Level (dBm)	Limit (dBm)
149	5745	21.060	≤ 29.00
157	5785	21.610	≤ 29.00
165	5825	21.790	≤ 29.00

Peak Power Output (dBm)										
MCS Index										Required Limit
Channel No	Frequency (MHz)	Data Rate								
		8	9	10	11	12	13	14	15	
149	5745	21.060	--	--	--	--	--	--	--	≤ 29.00
157	5785	21.610	23.150	23.020	22.890	22.750	22.600	22.460	22.320	≤ 29.00
165	5825	21.790	--	--	--	--	--	--	--	≤ 29.00

Note:

Directional Antenna=10log(N)+Max Gain =7dBi

Required Limit=30dBm-(7dBi-6dB)=29dBm

Channel 149 (5745MHz)

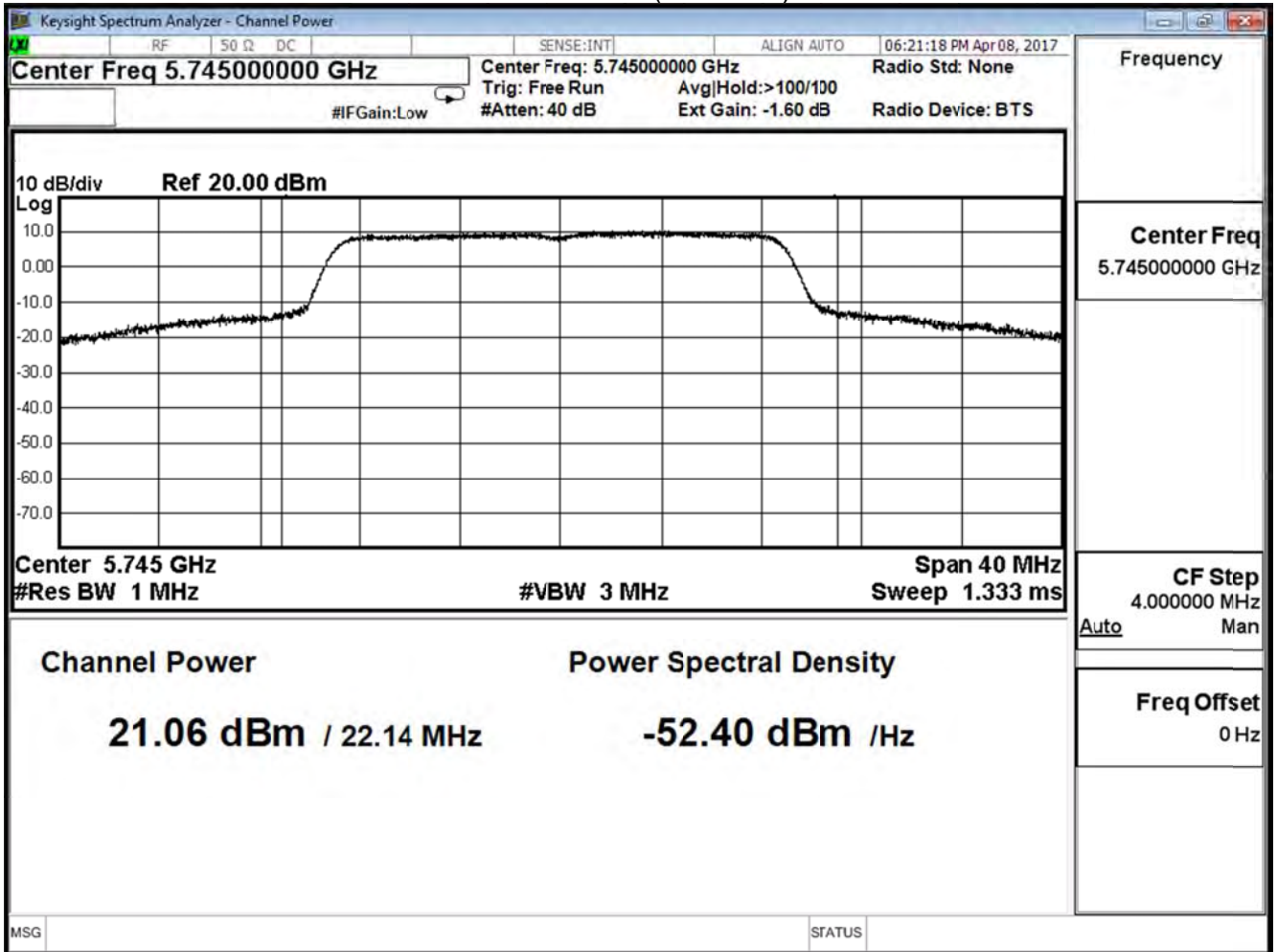

Channel 157 (5785MHz)

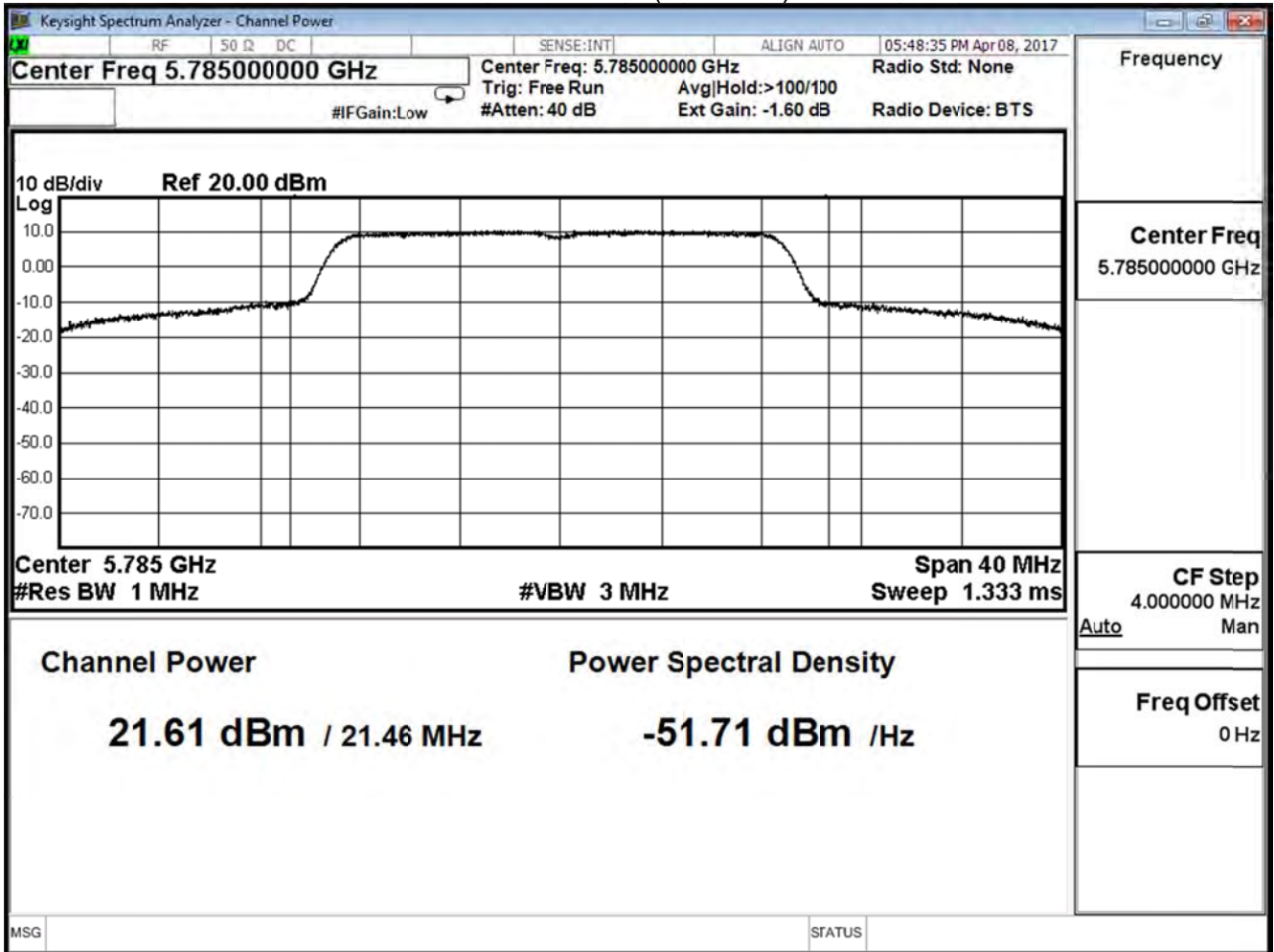

Channel 165 (5825MHz)

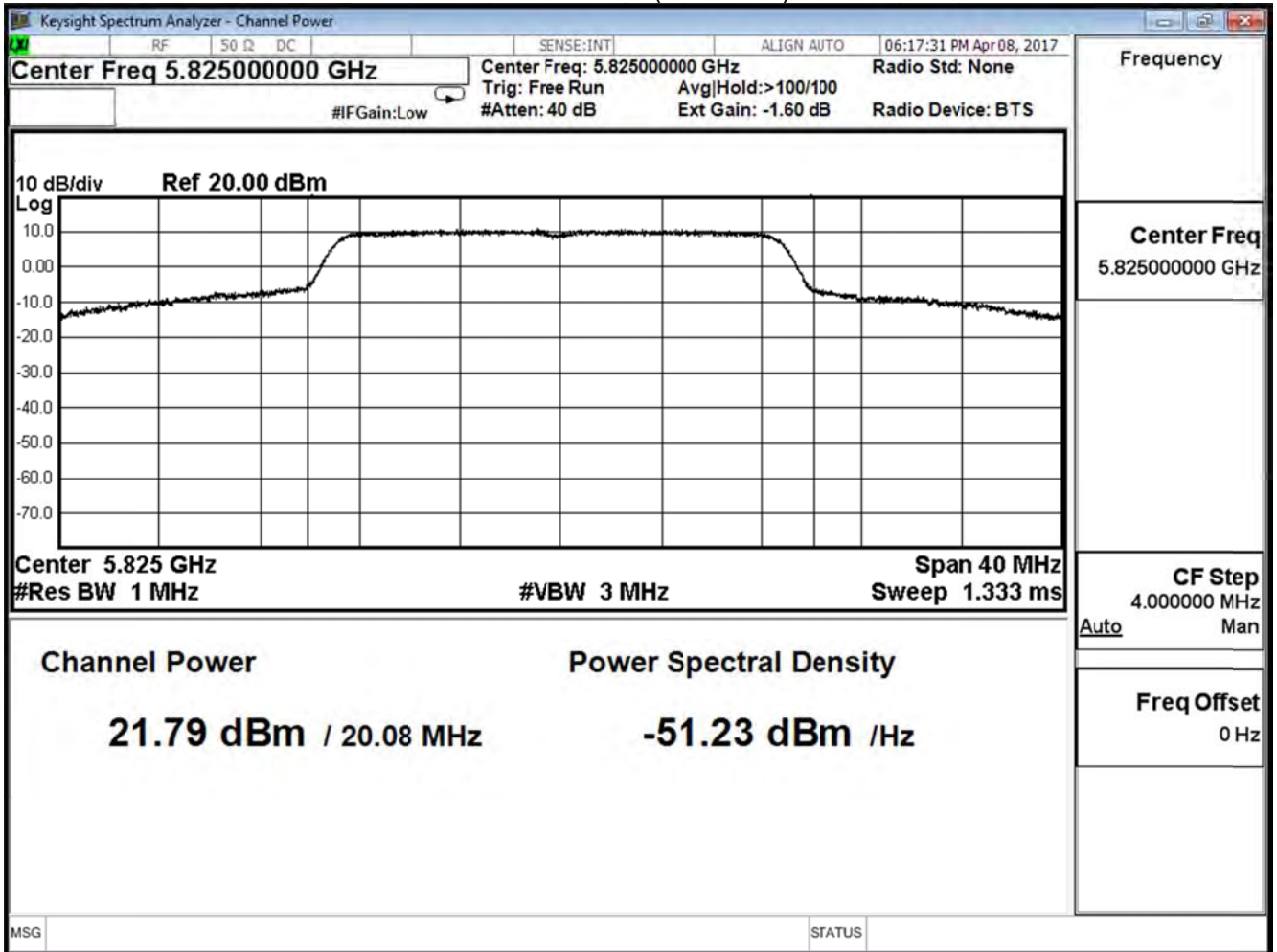

Product	Lyra		
Test Item	Peak Transmit power		
Test Mode	Mode 2: Tx-AD2055320 BF Mode		
Date of Test	2017/04/08	Test Site	SR10-H

IEEE 802.11n20 (ANT 1)			
Channel No.	Frequency (MHz)	Measure Level (dBm)	Limit (dBm)
149	5745	20.950	≤ 29.00
157	5785	21.410	≤ 29.00
165	5825	21.760	≤ 29.00

The worst emission of data rate is 8 Mbps

Peak Power Output (dBm)										
MCS Index										Required Limit
Channel No	Frequency (MHz)	Data Rate								
		8	9	10	11	12	13	14	15	
149	5745	20.950	--	--	--	--	--	--	--	≤ 29.00
157	5785	21.410	21.330	21.180	21.010	19.890	19.720	19.660	19.450	≤ 29.00
165	5825	21.760	--	--	--	--	--	--	--	≤ 29.00

Note:

Directional Antenna=10log(N)+Max Gain =7dBi

Required Limit=30dBm-(7dBi-6dB)=29dBm

Channel 149 (5745MHz)

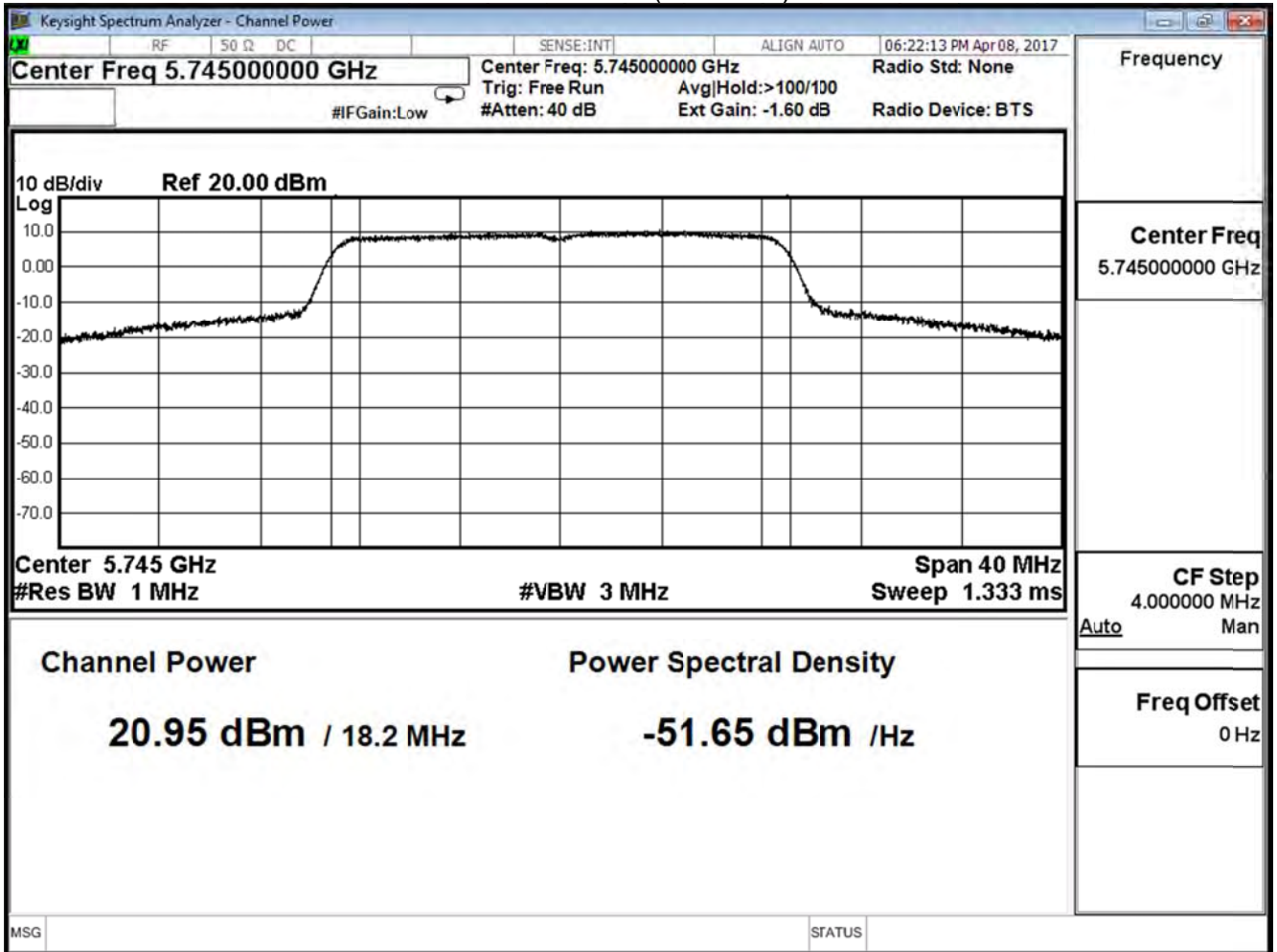

Channel 157 (5785MHz)

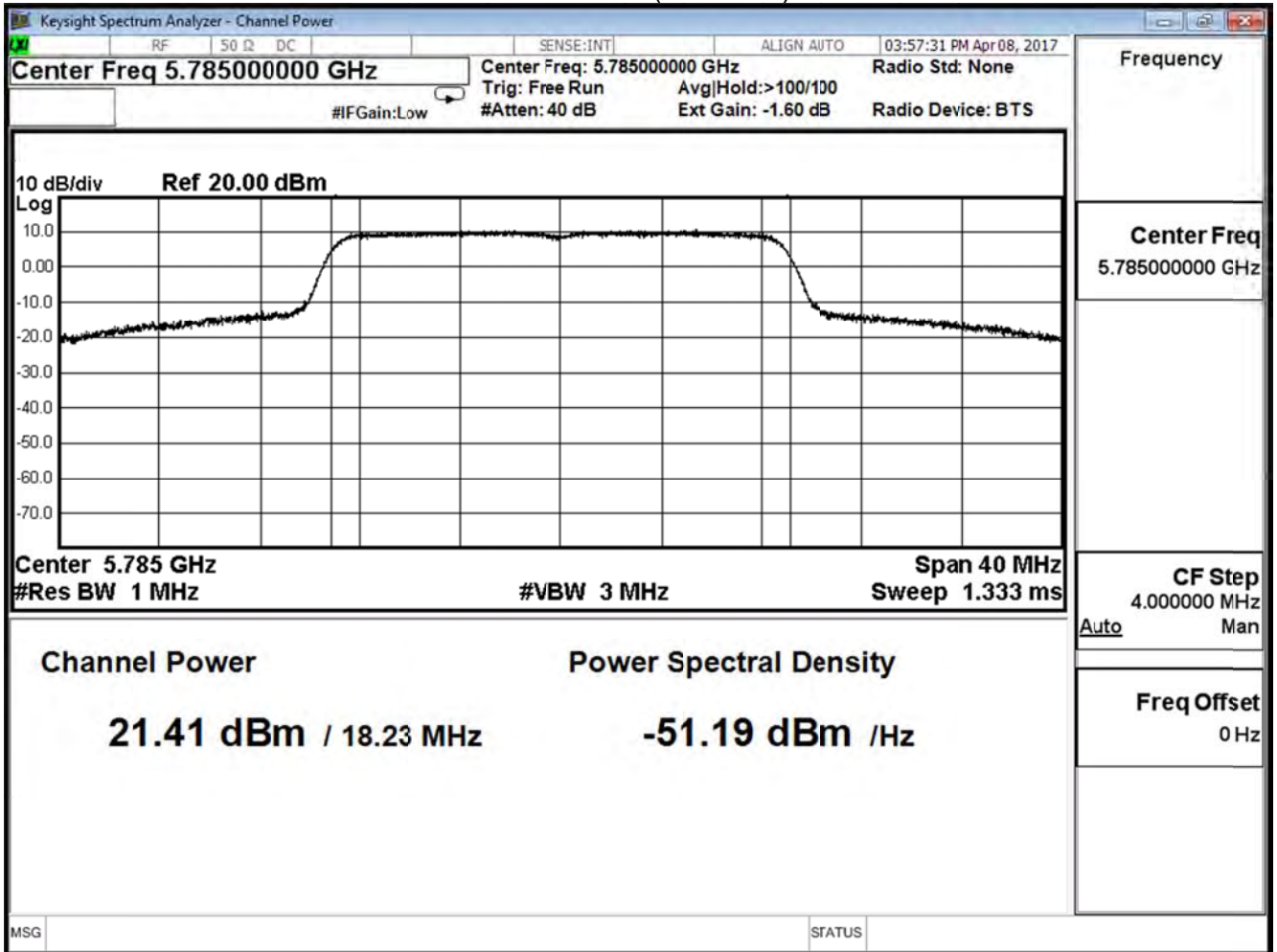

Channel 165 (5825MHz)

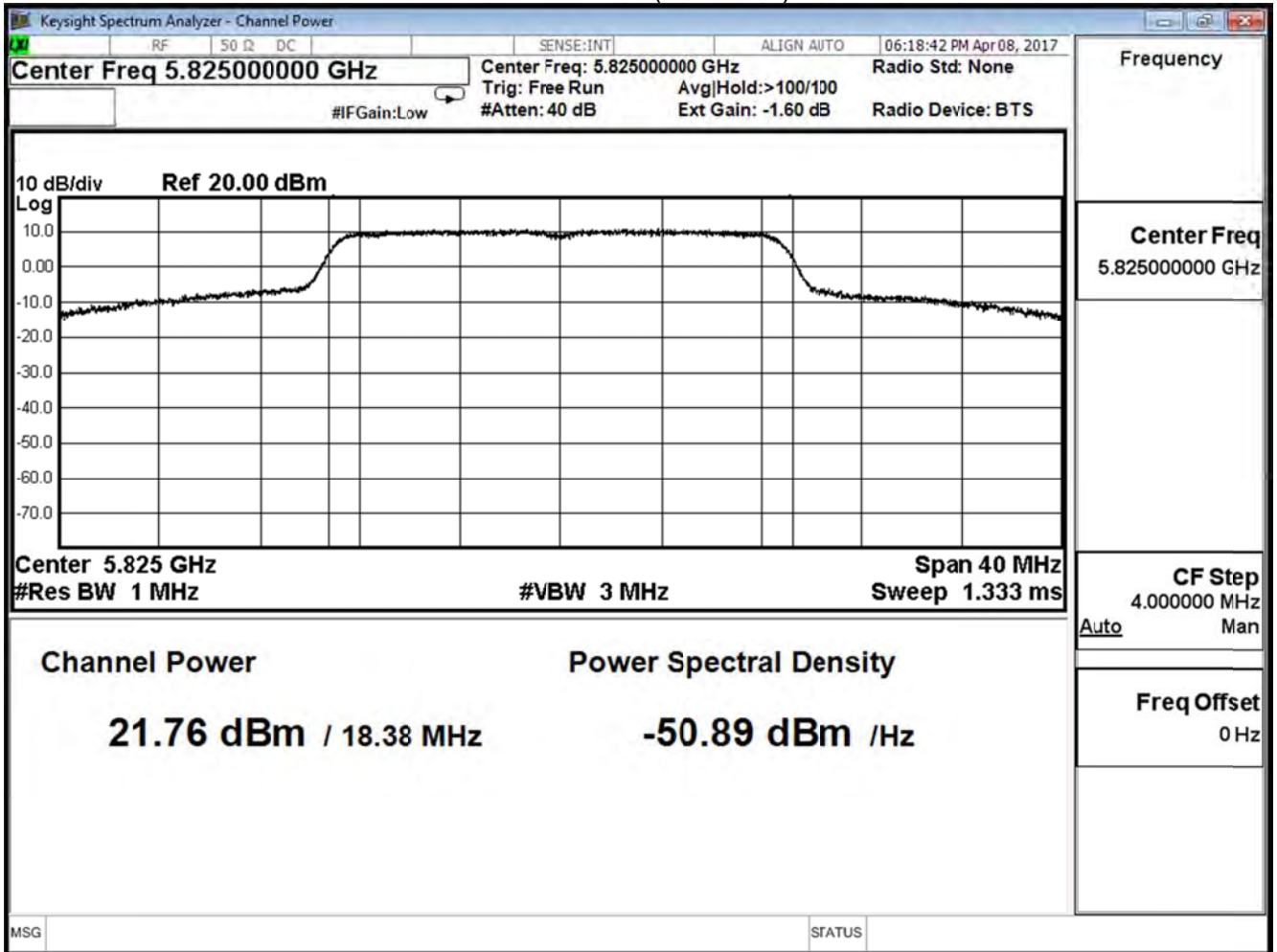

Product	Lyra		
Test Item	Peak Transmit power		
Test Mode	Mode 2: Tx-AD2055320 BF Mode		
Date of Test	2017/04/12	Test Site	SR10-H

IEEE 802.11n20 (ANT 0+1)			
Channel No.	Frequency (MHz)	Measure Level (dBm)	Limit (dBm)
149	5745	24.016	≤ 29.00
157	5785	24.521	≤ 29.00
165	5825	24.785	≤ 29.00

Product	Lyra		
Test Item	Peak Transmit power		
Test Mode	Mode 2: Tx-AD2055320 BF Mode		
Date of Test	2017/04/12	Test Site	SR10-H

IEEE 802.11n40 (ANT 0)			
Channel No.	Frequency (MHz)	Measure Level (dBm)	Limit (dBm)
151	5755	20.710	≤ 29.00
159	5795	22.200	≤ 29.00

The worst emission of data rate is 8 Mbps.

Peak Power Output (dBm)										
MCS Index										Required Limit
Channel No	Frequency (MHz)	Data Rate								
		8	9	10	11	12	13	14	15	
151	5755	20.710	--	--	--	--	--	--	--	≤ 29.00
159	5795	22.200	22.060	21.910	21.760	21.620	21.470	21.320	21.180	≤ 29.00

Note:

Directional Antenna=10log(N)+Max Gain =7dBi

Required Limit=30dBm-(7dBi-6dB)=29dBm

Channel 151 (5755MHz)

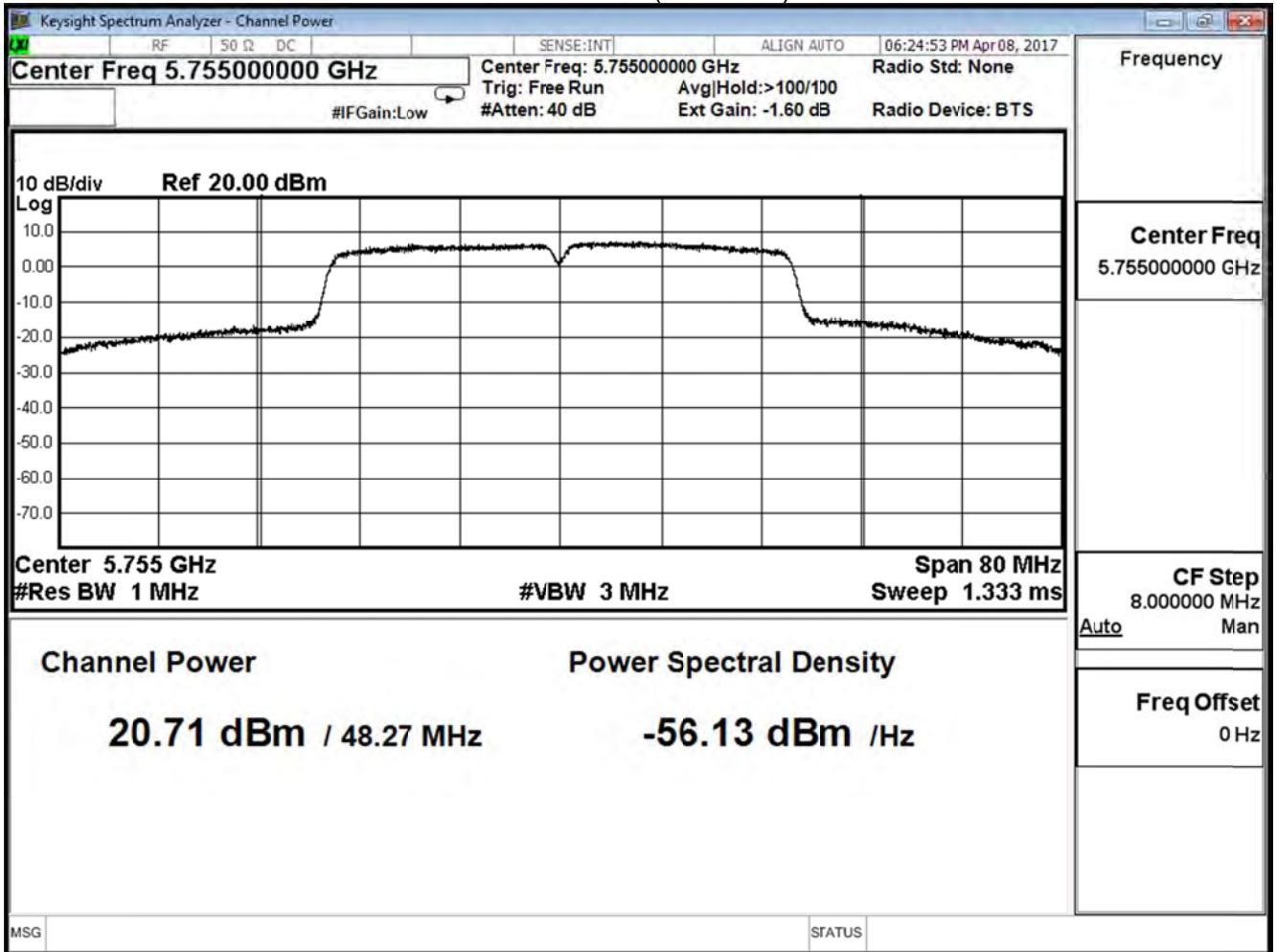

Channel 159 (5795MHz)

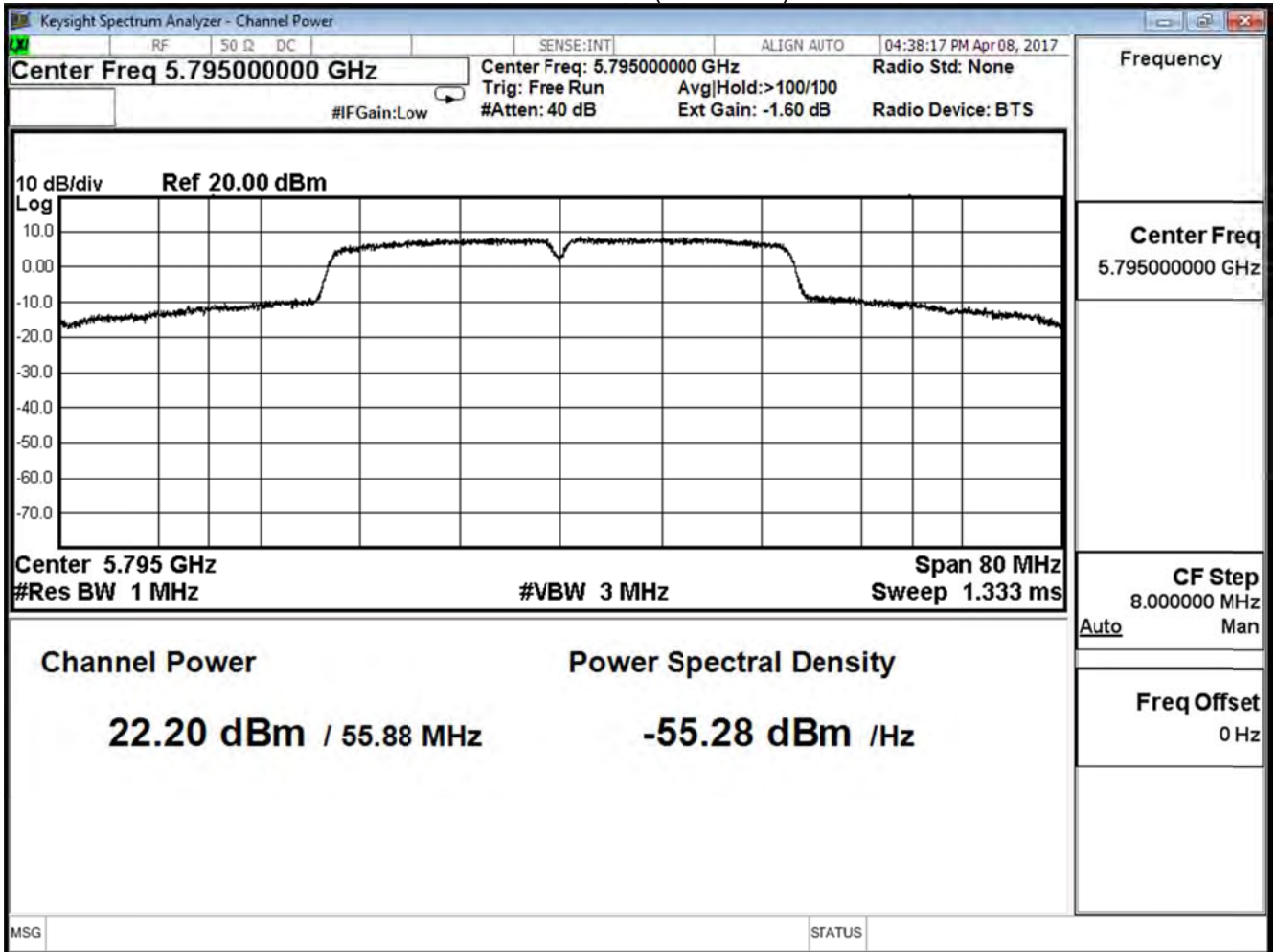

Product	Lyra		
Test Item	Peak Transmit power		
Test Mode	Mode 2: Tx-AD2055320 BF Mode		
Date of Test	2017/04/12	Test Site	SR10-H

IEEE 802.11n40 (ANT 1)			
Channel No.	Frequency (MHz)	Measure Level (dBm)	Limit (dBm)
151	5755	20.680	≤ 29.00
159	5795	21.830	≤ 29.00

The worst emission of data rate is 8 Mbps.

Peak Power Output (dBm)										
MCS Index										Required Limit
Channel No	Frequency (MHz)	Data Rate								
		8	9	10	11	12	13	14	15	
151	5755	20.680	--	--	--	--	--	--	--	≤ 29.00
159	5795	21.830	21.700	21.560	21.430	21.290	21.160	21.010	20.870	≤ 29.00

Note:

Directional Antenna=10log(N)+Max Gain =7dBi

Required Limit=30dBm-(7dBi-6dB)=29dBm

Channel 151 (5755MHz)

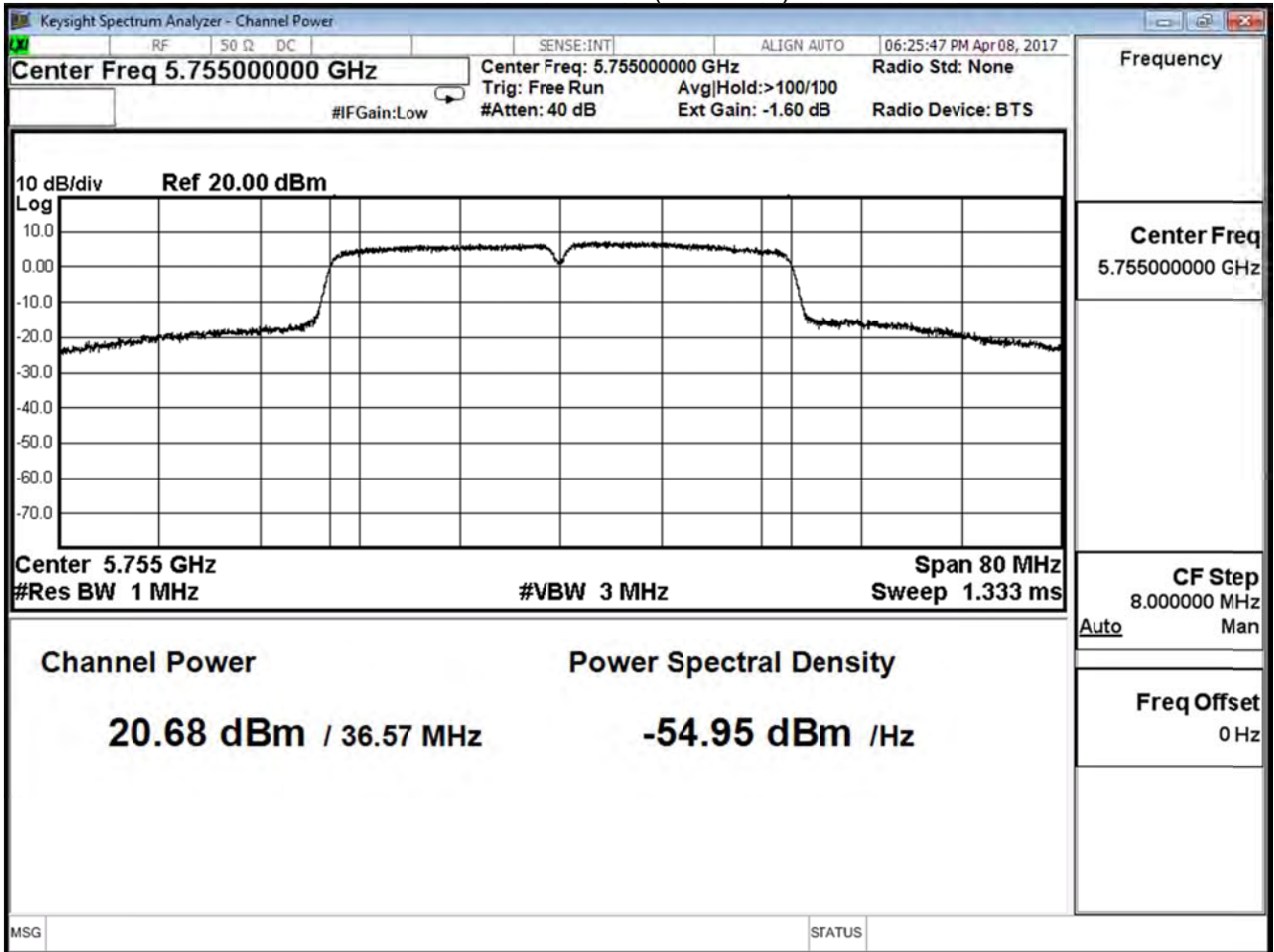

Channel 159 (5795MHz)

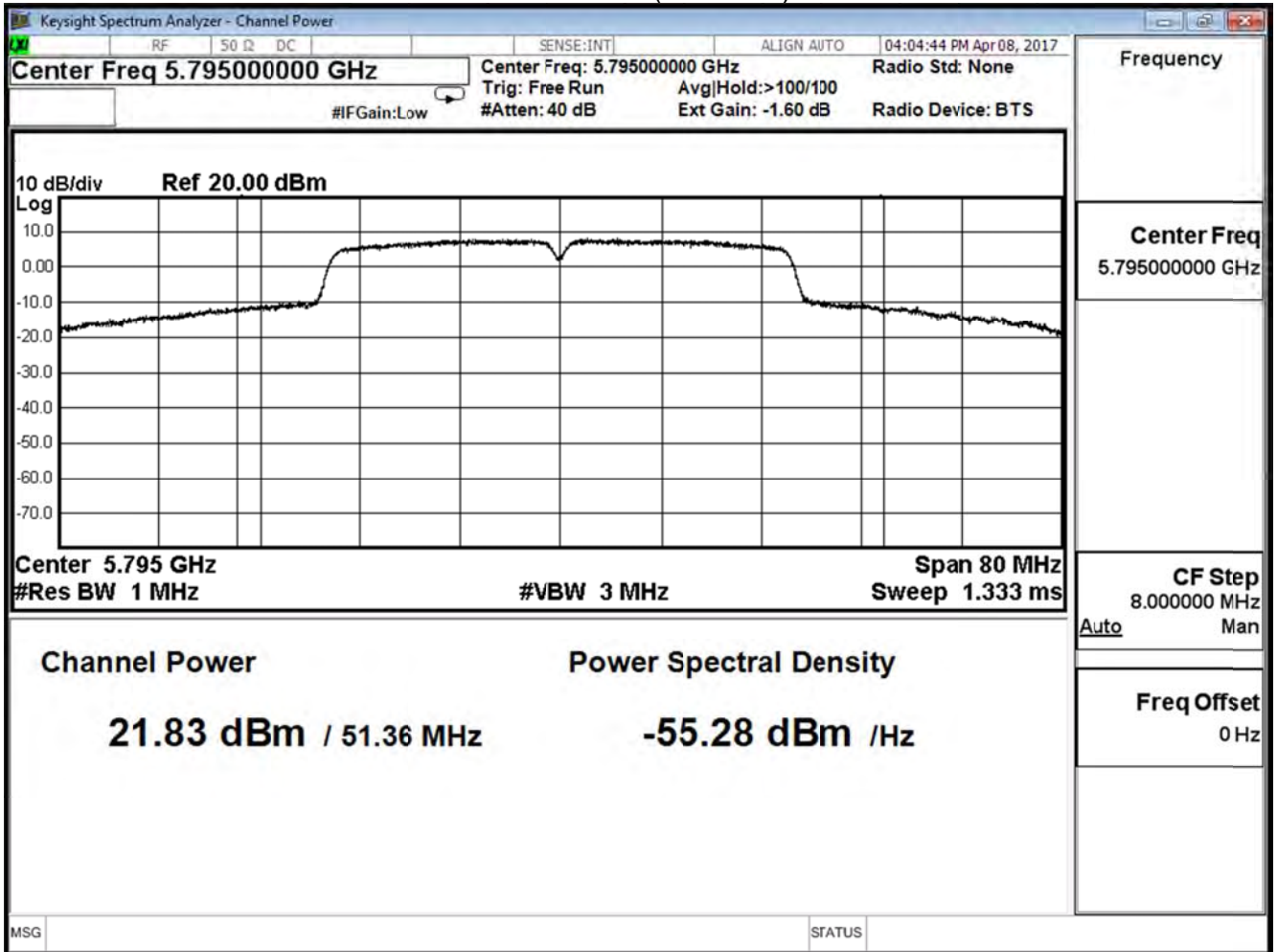

Product	Lyra		
Test Item	Peak Transmit power		
Test Mode	Mode 2: Tx-AD2055320 BF Mode		
Date of Test	2017/04/12	Test Site	SR10-H

IEEE 802.11n40 (ANT 0+1)			
Channel No.	Frequency (MHz)	Measure Level (dBm)	Limit (dBm)
151	5755	23.705	≤ 29.00
159	5795	25.029	≤ 29.00

Note:

Directional Antenna= $10\log(N)+\text{Max Gain} = 7\text{dBi}$

Required Limit= $30\text{dBm}-(7\text{dBi}-6\text{dB})=29\text{dBm}$

Product	Lyra		
Test Item	Peak Transmit power		
Test Mode	Mode 2: Tx-AD2055320 BF Mode		
Date of Test	2017/04/08	Test Site	SR10-H

IEEE 802.11ac80 (ANT 0)			
Channel No.	Frequency (MHz)	Measure Level (dBm)	Limit (dBm)
155	5775	13.640	≤ 29.00

The worst emission of data rate is 0 Mbps.

Peak Power Output (dBm)												
MCS Index												Require Limit
Channel No	Frequency (MHz)	Data Rate										
		0	1	2	3	4	5	6	7	8	9	
155	5775	13.640	13.510	13.370	13.230	13.090	12.940	12.790	12.650	12.520	12.380	≤ 29.00

Note:

Directional Antenna=10log(N)+Max Gain =7dBi

Required Limit=30dBm-(7dBi-6dB)=29dBm

Channel 155 (5775MHz)

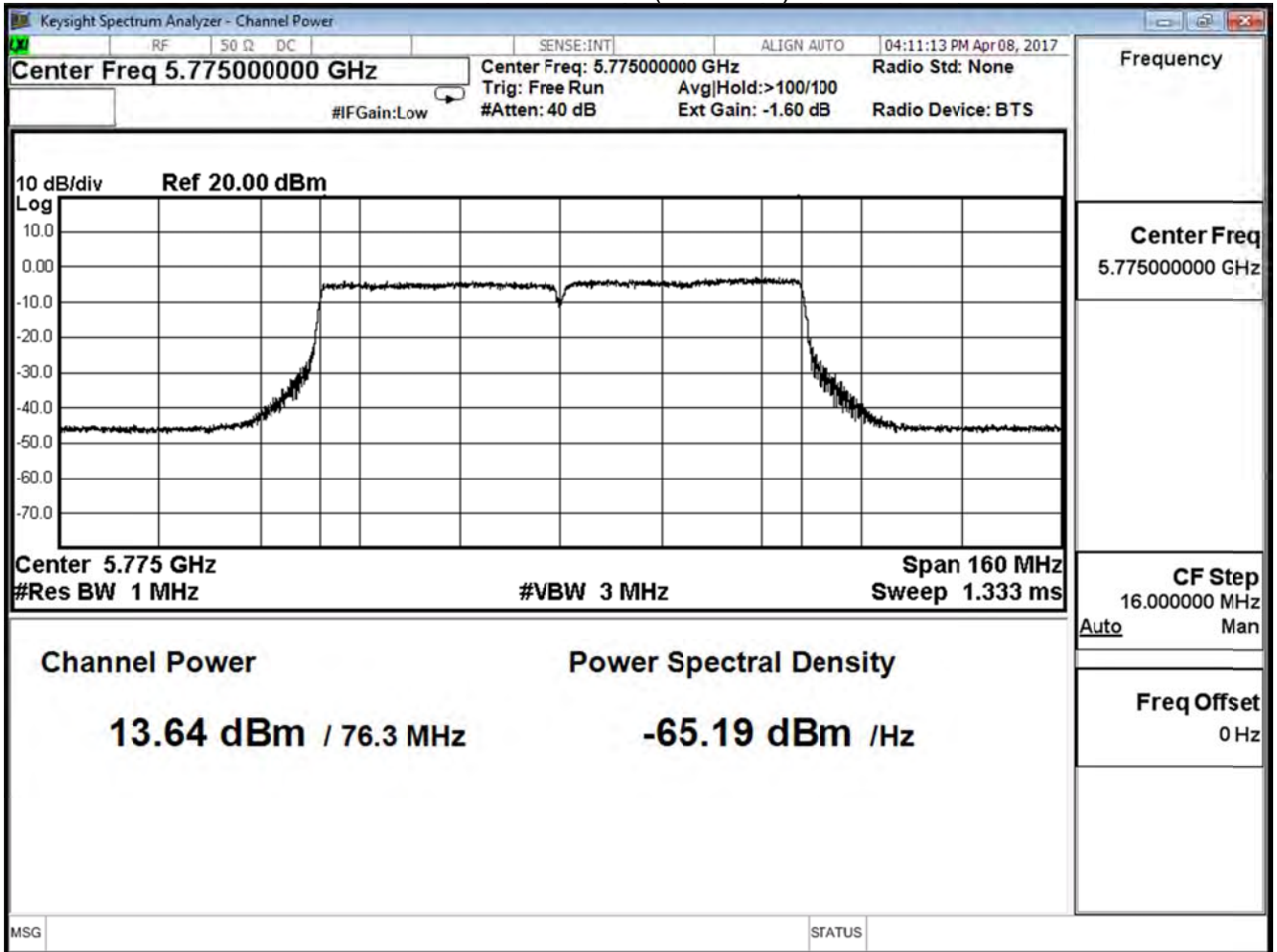

Product	Lyra		
Test Item	Peak Transmit power		
Test Mode	Mode 2: Tx-AD2055320 BF Mode		
Date of Test	2017/04/08	Test Site	SR10-H

IEEE 802.11ac80 (ANT 1)			
Channel No.	Frequency (MHz)	Measure Level (dBm)	Limit (dBm)
155	5775	13.440	≤29.00

The worst emission of data rate is 0 Mbps.

Peak Power Output (dBm)												
MCS Index												Require Limit
Channel No	Frequency (MHz)	Data Rate										
		0	1	2	3	4	5	6	7	8	9	
155	5775	13.440	13.300	13.160	13.020	12.890	12.750	12.600	12.450	12.310	12.170	≤29.00

Note:

Directional Antenna=10log(N)+Max Gain =7dBi

Required Limit=30dBm-(7dBi-6dB)=29dBm

Channel 155 (5775MHz)

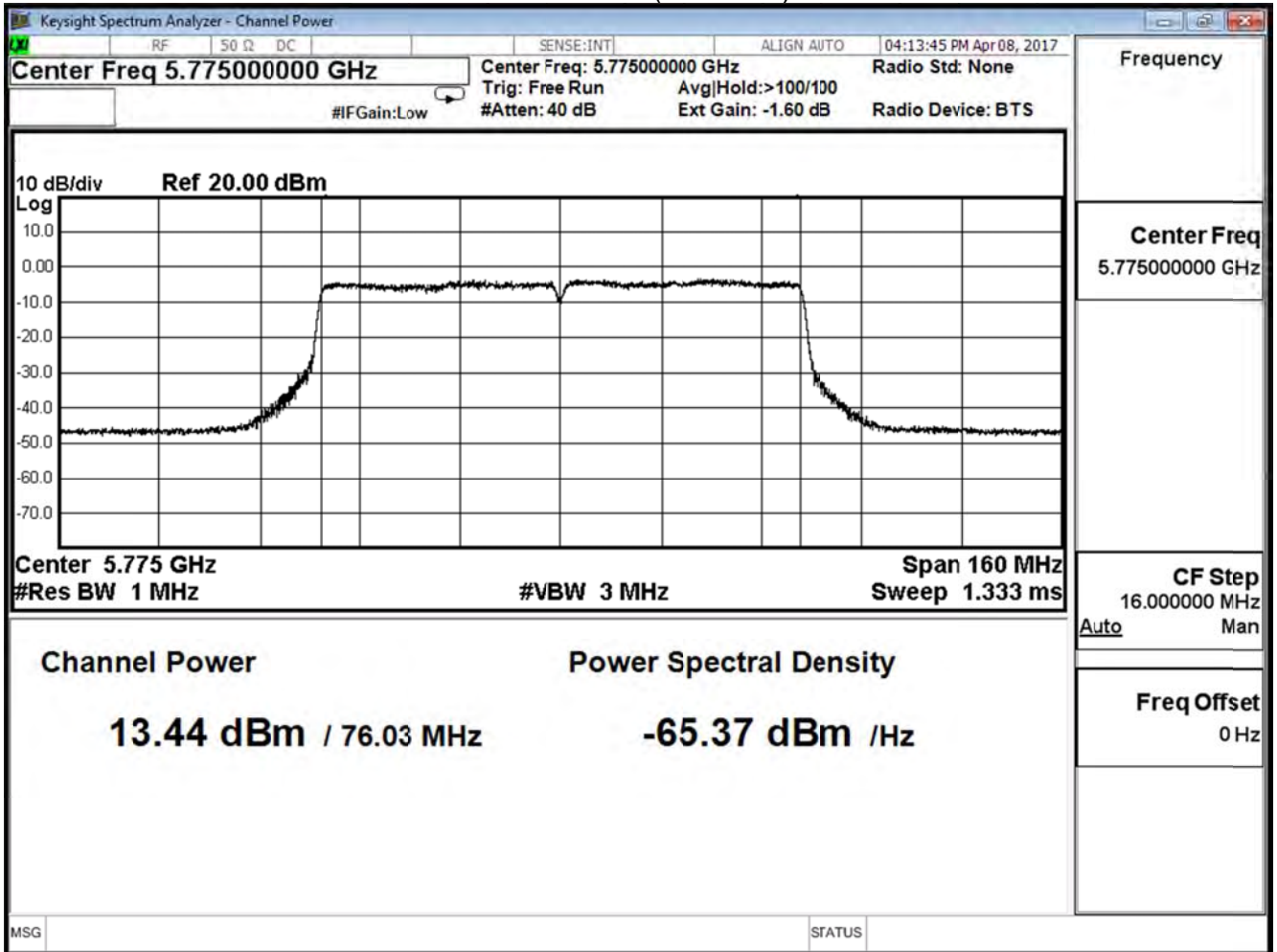

Product	Lyra		
Test Item	Peak Transmit power		
Test Mode	Mode 2: Tx-AD2055320 BF Mode		
Date of Test	2017/04/08	Test Site	SR10-H

IEEE 802.11ac80 (ANT 0+1)			
Channel No.	Frequency (MHz)	Measure Level (dBm)	Limit (dBm)
155	5775	16.551	≤ 28.31

Note:

Directional Antenna= $10\log(N)+\text{Max Gain} = 7\text{dBi}$

Required Limit= $30\text{dBm}-(7\text{dBi}-6\text{dB})=29\text{dBm}$