



Test report No.: 2380887R-RFUSV09S-A

TEST REPORT

Product Name	Wireless headphone
Trademark	ASUS
Model and /or type reference	R55ES(L), R55ES(R)
FCC ID	MSQ-RCTWSNEL MSQ-RCTWSNER
Applicant's name / address	ASUSTeK COMPUTER INC. 1F., No. 15, Lide Rd., Beitou Dist., Taipei City 112, Taiwan
Manufacturer's name	ASUSTeK COMPUTER INC.
Test method requested, standard	FCC CFR Title 47 Part 15 Subpart C ANSI C63.4: 2014, ANSI C63.10: 2013
Verdict Summary	IN COMPLIANCE
Documented By (Senior Project Specialist / Genie Chang)	<i>Genie Chang</i>
Tested By (Senior Engineer / Ivan Chuang)	<i>Ivan Chuang</i>
Approved By (Senior Engineer / Jack Hsu)	<i>Jack Hsu</i>
Date of Receipt	2023/08/29
Date of Issue	2023/12/13
Report Version	V1.0

INDEX

Page

1. General Information.....	5
1.1. EUT Description.....	5
1.2. Tested System Details.....	7
1.3. Configuration of Test System.....	8
1.4. EUT Exercise Software.....	8
1.5. Test Facility.....	9
1.6. List of Test Equipment.....	10
1.7. Uncertainty.....	11
2. Conducted Emission.....	12
2.1. Test Setup.....	12
2.2. Limits.....	12
2.3. Test Procedure.....	13
2.4. Test Result of Conducted Emission.....	14
3. Radiated Emission.....	15
3.1. Test Setup.....	15
3.2. Limits.....	16
3.3. Test Procedure.....	17
3.4. Test Result of Radiated Emission.....	18
4. Band Edge.....	34
4.1. Test Setup.....	34
4.2. Limits.....	34
4.3. Test Procedure.....	35
4.4. Test Result of Band Edge.....	36
5. Duty Cycle.....	44
5.1. Test Setup.....	44
5.2. Test Result of Duty Cycle.....	45

Appendix 1: EUT Test Photographs

Appendix 2: Product Photos-Please refer to the file: 2380887R-Product Photos

Competences and Guarantees

DEKRA is a testing laboratory competent to carry out the tests described in this report.

In order to assure the traceability to other national and international laboratories, DEKRA has a calibration and maintenance program for its measurement equipment.

DEKRA guarantees the reliability of the data presented in this report, which is the result of the measurements and the tests performed to the item under test on the date and under the conditions stated in the report and it is based on the knowledge and technical facilities available at DEKRA at the time of performance of the test.

DEKRA is liable to the client for the maintenance of the confidentiality of all information related to the item under test and the results of the test.

The results presented in this Test Report apply only to the particular item under test established in this document.

IMPORTANT: No parts of this report may be reproduced or quoted out of context, in any form or by any means, except in full, without the previous written permission of DEKRA.

General conditions

1. The test results relate only to the samples tested.
2. The test results shown in the test report are traceable to the national/international standard through the calibration report of the equipment and evaluated measurement uncertainty herein.
3. This report must not be used to claim product endorsement by TAF or any agency of the government.
4. The test report shall not be reproduced without the written approval of DEKRA Testing and Certification Co., Ltd.
5. Measurement uncertainties evaluated for each testing system and associated connections are given here to provide the system information for reference. Compliance determinations do not take into account measurement uncertainties for each testing system, but are based on the results of the compliance measurement.

Revision History

Report No.	Version	Description	Issued Date
2380887R-RFUSV09S-A	V1.0	Initial issue of report.	2023/12/13

1. General Information

1.1. EUT Description

Product Name	Wireless headphone
Trade Name	ASUS
Model No.	R55ES(L), R55ES(R)
EUT Rated Voltage	DC 3.85V by Battery
EUT Test Voltage	DC 3.85V by Battery
Frequency Range	2402-2480MHz
Channel Number	40
Type of Modulation	GFSK
Channel Control	Auto
Wireless headphone	ASUS / R55ES(L)
Wireless headphone	ASUS / R55ES(R)
Wireless Charge Case	ASUS / R55ES
USB Cable	ASUS / R55ES, Shielded, 0.6m
USB-C Wireless Dongle	ASUS / R55ES-D
USB-C to USB-A adaptor dongle	ASUS / R55ES
Battery	Hynotech / CH1154AA

Antenna List

No.	Manufacturer	Part No.	Antenna Type	Peak Gain
1	Cicent (Right)	102BK3F1421	Monopole	-1.2 dBi for 2400 MHz
2	Cicent (Left)	102BK3F1420	Monopole	-0.2 dBi for 2400 MHz

Note: 1. The antenna of EUT is conforming to FCC 15.203.

2. The antenna gain as by the manufacturer provided.

Center Frequency of Each Channel:

Channel	Frequency (MHz)	Channel	Frequency (MHz)	Channel	Frequency (MHz)	Channel	Frequency (MHz)
00	2402	01	2404	02	2406	03	2408
04	2410	05	2412	06	2414	07	2416
08	2418	09	2420	10	2422	11	2424
12	2426	13	2428	14	2430	15	2432
16	2434	17	2436	18	2438	19	2440
20	2442	21	2444	22	2446	23	2448
24	2450	25	2452	26	2454	27	2456
28	2458	29	2460	30	2462	31	2464
32	2466	33	2468	34	2470	35	2472
36	2474	37	2476	38	2478	39	2480

Note:

1. The EUT is a Wireless headphone with a built-in 2.4G wireless and Bluetooth transceiver, this report for 2.4G wireless transceiver.
2. Regarding to the operation frequency, the lowest, middle, and highest frequency are selected to perform the test.
3. The radiation measurements are performed in X, Y, Z axis positioning. Only the worst case is shown in the report.
4. The spectrum plot against conducted item only shows the worst case.
5. DEKRA has evaluated each test mode. Only the worst case is shown in the report.
6. These tests are conducted on a sample of the equipment for the purpose of demonstrating compliance of transmitter with Part 15 Subpart C Paragraph 15.249 for spread spectrum devices.

Test Mode	Mode 1	Transmit
	Mode 2	Charger mode

1.2. Tested System Details

The types for all equipment, plus descriptions of all cables used in the tested system (including inserted cards) are:

Product	Manufacturer	Model No.	Serial No.	Power Cord	
1	Notebook PC	DELL	Latitude 5580	2HRD7H2	N/A
2	Test Fixture	Mercury Electronics	FT232RL USB To UART	N/A	N/A

Cable Type	Cable Description	
A	USB Cable	Shielded, 1.8m
B	Signal Cable	Non-shielded, 0.07m

Charger mode

Product	Manufacturer	Model No.	Serial No.	Power Cord	
1	Power Adapter	Apple	A1385	N/A	N/A
2	Wireless Charge Case	ASUS	R55ES	N/A	N/A

Cable Type	Cable Description	
A	USB Cable	Shielded, 1.8m
B	USB Cable	Shielded, 0.6m

1.3. Configuration of Test System

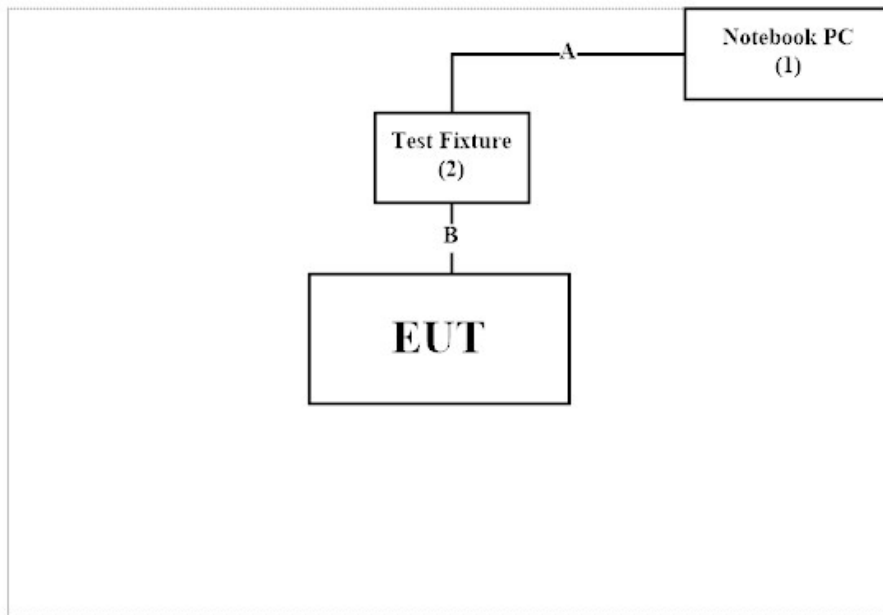

Charger mode

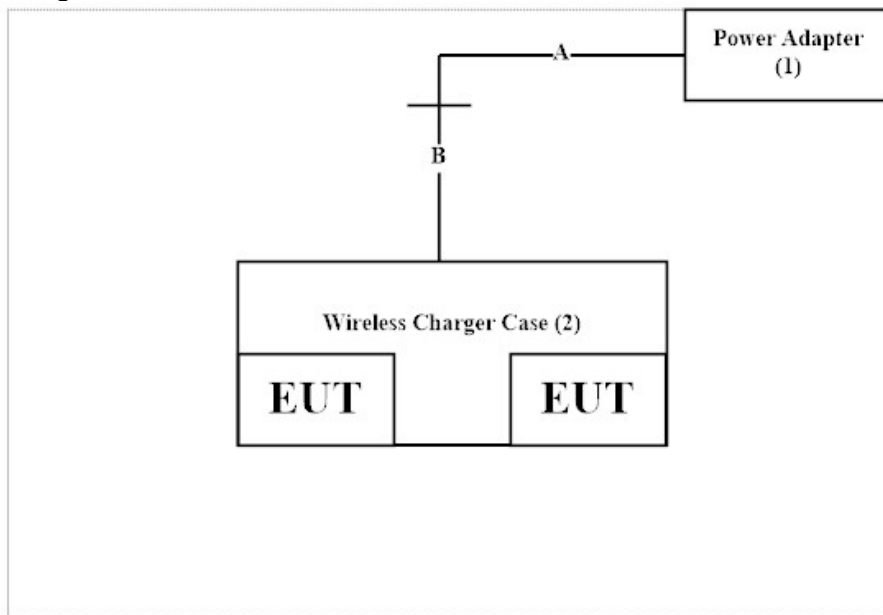

1.4. EUT Exercise Software

(1)	Setup the EUT as shown in Section 1.3.
(2)	Execute software “Airoha Tool Kit Version 3.5.6” on the EUT.
(3)	Start the continuous transmit.
(4)	Verify that the EUT works properly.

1.5. Test Facility

Ambient conditions in the laboratory:

Performed Item	Items	Required	Actual
Conducted Emission	Temperature (°C)	10~40 °C	26.7 °C
	Humidity (%RH)	10~90 %	58.0 %
Radiated Emission	Temperature (°C)	10~40 °C	21.6 °C
	Humidity (%RH)	10~90 %	63.8 %

USA	FCC Registration Number: TW0033
Canada	CAB Identifier Number: TW3023 / Company Number: 26930

Site Description	Accredited by TAF
	Accredited Number: 3023

Test Laboratory	DEKRA Testing and Certification Co., Ltd.
	Linkou Laboratory
Address	No.5-22, Ruishukeng Linkou District, New Taipei City, 24451, Taiwan, R.O.C
Performed Location	No. 26, Huaya 1st Rd., Guishan Dist., Taoyuan City 333411, Taiwan, R.O.C.
Phone Number	+886-3-275-7255
Fax Number	+886-3-327-8031

1.6. List of Test Equipment

For Conduction Measurements /HY-SR01

	Equipment	Manufacturer	Model No.	Serial No.	Cal. Date	Due Date
V	EMI Test Receiver	R&S	ESR7	101601	2023/06/20	2024/06/19
V	Two-Line V-Network	R&S	ENV216	101306	2023/03/16	2024/03/15
V	Two-Line V-Network	R&S	ENV216	101307	2023/08/17	2024/08/16
V	Coaxial Cable	SUHNER	RG400 BNC	RF001	2023/01/10	2024/01/09

Note:

1. All equipments are calibrated every one year.
2. The test instruments marked with “V” are used to measure the final test results.
3. Test Software Version: e3 230303 dekra V9.

For Conducted Measurements /HY-SR02

	Equipment	Manufacturer	Model No.	Serial No.	Cal. Date	Due Date
V	Spectrum Analyzer	R&S	FSV30	103466	2022/12/22	2023/12/21
V	Peak Power Analyzer	KEYSIGHT	8990B	MY51000539	2023/05/15	2024/05/14
V	Power Sensor	KEYSIGHT	N1923A	MY59240002	2023/05/18	2024/05/17
V	Power Sensor	KEYSIGHT	N1923A	MY59240003	2023/05/18	2024/05/17

Note:

1. All equipments are calibrated every one year.
2. The test instruments marked with “V” are used to measure the final test results.
3. Test Software Version: RF Conducted Test Tools R3 V3.0.1.14.

For Radiated Measurements / HY-CB02

	Equipment	Manufacturer	Model No.	Serial No.	Cal. Date	Due Date
	Loop Antenna	AMETEK	HLA6121	49611	2023/02/21	2024/02/20
V	Bi-Log Antenna	SCHWARZBECK	VULB9168	9168-0678	2021/09/23	2023/09/22
V	Horn Antenna	RF SPIN	DRH18-E	210503A18ES	2023/02/24	2024/02/23
V	Horn Antenna	Com-Power	AH-840	101101	2021/11/30	2023/11/29
V	Pre-Amplifier	SGH	EM330	60736	2023/01/10	2024/01/09
V	Pre-Amplifier	SGH	PRAMP118	20200203	2023/01/10	2024/01/09
V	Pre-Amplifier	EMCI	EMC05820SE	980285	2023/01/10	2024/01/09
V	Pre-Amplifier	EMCI	EMC184045SE	980369	2023/01/10	2024/01/09
	Coaxial Cable	EMCI	EMC102-KM-KM-600	1160314		
	Coaxial Cable	EMCI	EMC102-KM-KM-7000	170242		
V	Filter	MICRO TRONICS	BRM50702	G249	2023/01/05	2024/01/04
	Filter	MICRO TRONICS	BRM50716	G187	2023/01/05	2024/01/04
V	EMI Test Receiver	R&S	ESR7	101601	2023/06/20	2024/06/19
V	Spectrum Analyzer	R&S	FSV3044	101113	2023/02/04	2024/02/03
V	Coaxial Cable	SGH	HA800	GD20110223-2	2023/01/10	2024/01/09
	Coaxial Cable	SGH	HA800	GD20110222-4		
	Coaxial Cable	SGH	SGH18	2021005-2		
	Coaxial Cable	SGH	SGH18	202108-5		

Note:

1. Bi-Log Antenna and Horn Antenna(AH-840) is calibrated every two years, the other equipments are calibrated every one year.
2. The test instruments marked with “V” are used to measure the final test results.
3. Test Software Version: e3 230303 dekra V9.

1.7. Uncertainty

Uncertainties have been calculated according to the DEKRA internal document.

The reported expanded uncertainties are based on a standard uncertainty multiplied by a coverage factor of $k=2$, providing a level of confidence of approximately 95%.

Measurement uncertainties evaluated for each testing system and associated connections are given here to provide the system information for reference. Compliance determinations do not take into account measurement uncertainties for each testing system, but are based on the results of the compliance measurement.

Test item	Uncertainty
Conducted Emission	± 3.50 dB
Radiated Emission	9 kHz~30 MHz: ± 3.88 dB 30 MHz~1 GHz: ± 4.42 dB 1 GHz~18 GHz: ± 4.28 dB 18 GHz~40 GHz: ± 3.90 dB
Band Edge	9 kHz~30 MHz: ± 3.88 dB 30 MHz~1 GHz: ± 4.42 dB 1 GHz~18 GHz: ± 4.28 dB 18 GHz~40 GHz: ± 3.90 dB
Duty Cycle	± 0.53 %

2. Conducted Emission

2.1. Test Setup

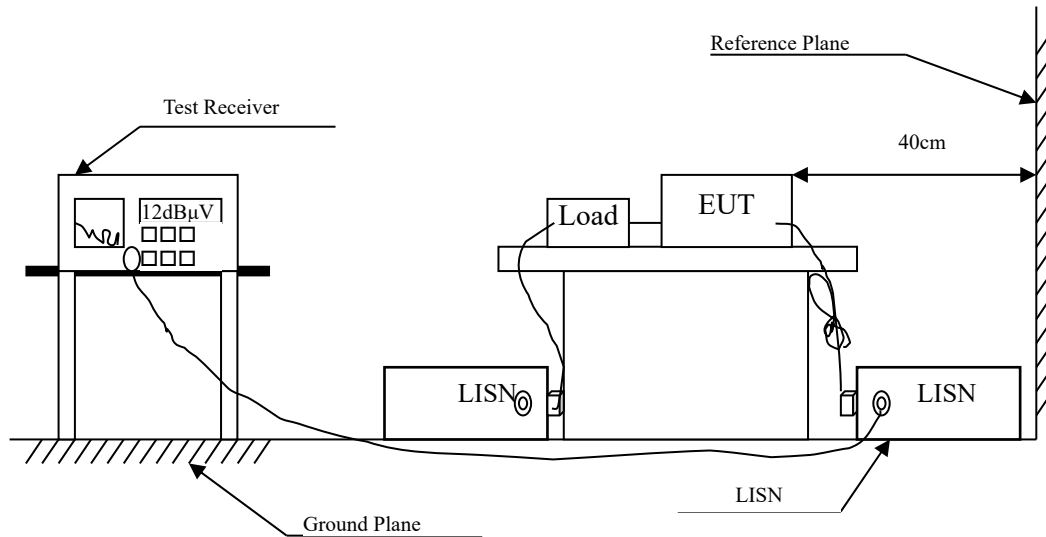

2.2. Limits

FCC Part 15 Subpart C Paragraph 15.207 (dB μ V) Limit		
Frequency MHz	Limits	
	QP	AV
0.15 - 0.50	66-56	56-46
0.50-5.0	56	46
5.0 - 30	60	50

Remarks: In the above table, the tighter limit applies at the band edges.

2.3. Test Procedure

The EUT and simulators are connected to the main power through a line impedance stabilization network (L.I.S.N.). This provides a 50 ohm /50uH coupling impedance for the measuring equipment. The peripheral devices are also connected to the main power through a LISN that provides a 50ohm /50uH coupling impedance with 50ohm termination. (Please refers to the block diagram of the test setup and photographs.)

Both sides of A.C. line are checked for maximum conducted interference. In order to find the maximum emission, the relative positions of equipment and all of the interface cables must be changed according to ANSI C63.4: 2014 on conducted measurement.

Conducted emissions were investigated over the frequency range from 0.15MHz to 30MHz using a receiver bandwidth of 9kHz.

2.4. Test Result of Conducted Emission

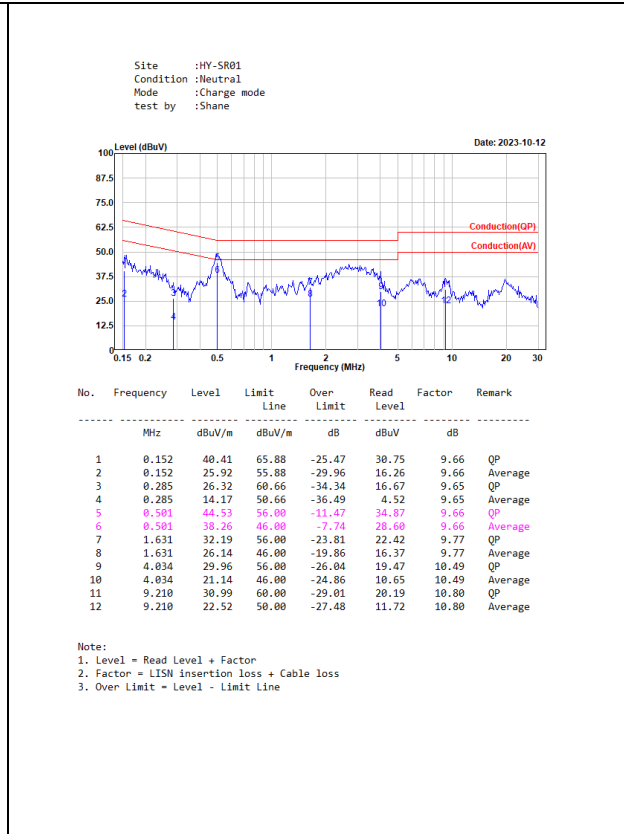
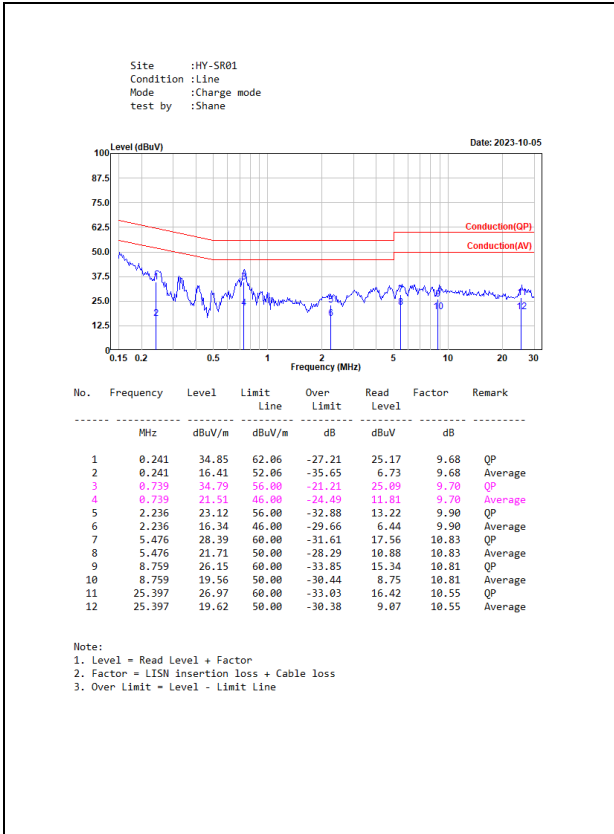

3. Radiated Emission

3.1. Test Setup

Radiated Emission Under 30MHz

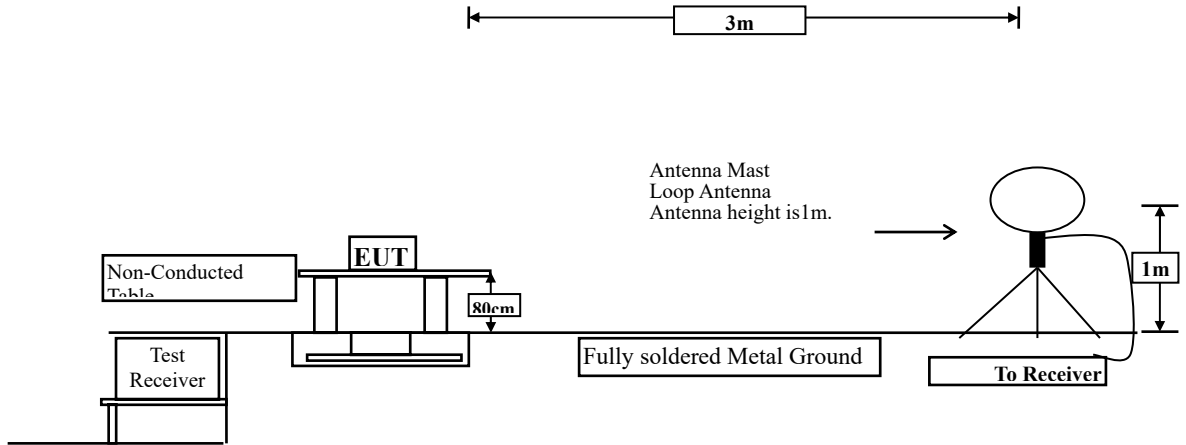

Radiated Emission Below 1GHz

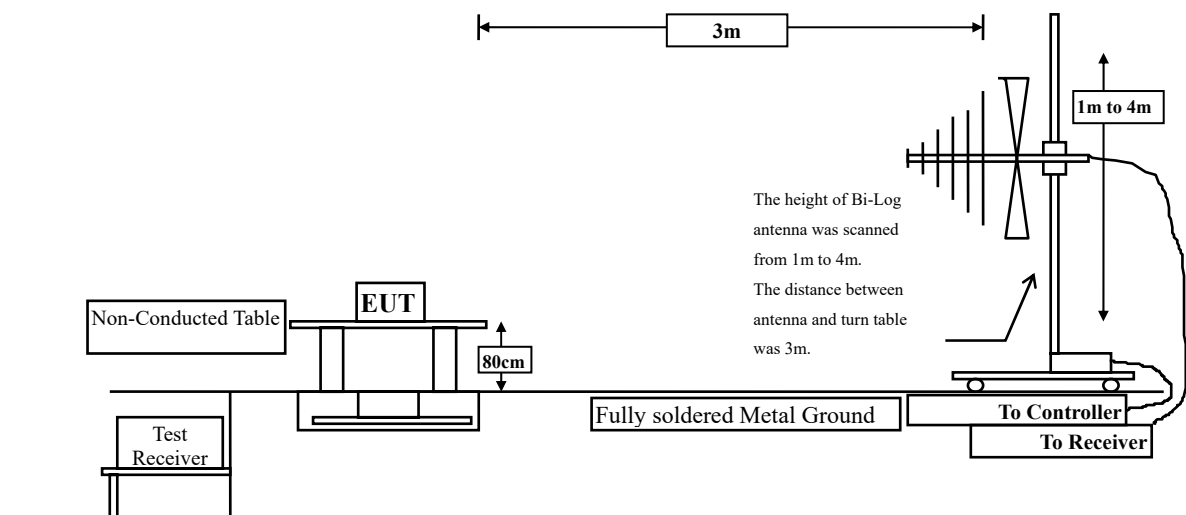

Radiated Emission Above 1GHz

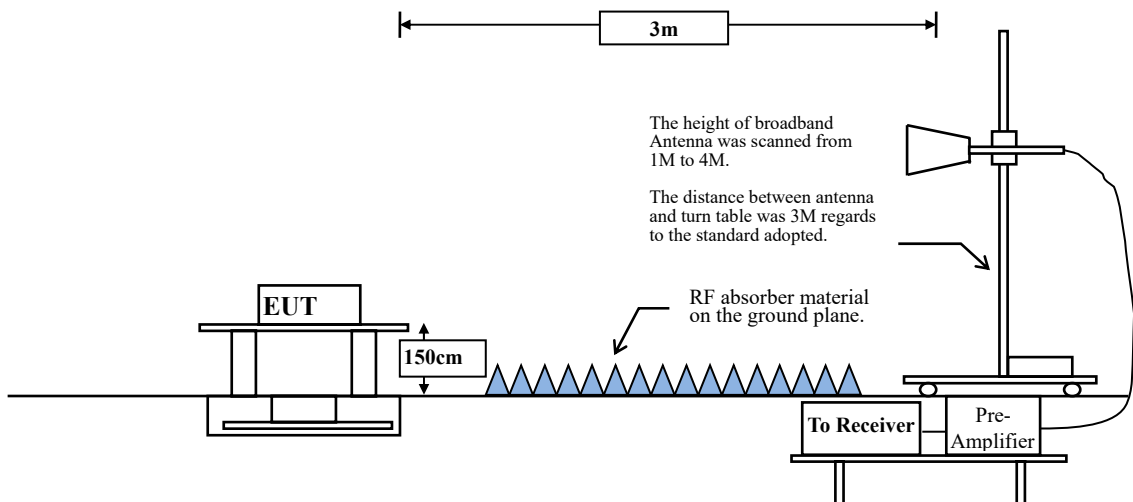

3.2. Limits

➤ **Fundamental and Harmonics Emission Limits**

FCC Part 15 Subpart C Paragraph 15.249 Limits				
Frequency MHz	Field Strength of Fundamental		Field Strength of Harmonics	
	(mV/m @3m)	(dBµV /m @3m)	(uV/m @3m)	(dBµV /m @3m)
902-928	50	94	500	54
2400-2483.5	50	94	500	54
5725-5875	50	94	500	54
24000-24250	250	108	2500	68

- Remarks :
1. RF Voltage (dBµV /m) = 20 log RF Voltage (uV/m)
 2. Distance refers to the distance in meters between the measuring instrument antenna and the closed point of any part of the device or system.

➤ **General Radiated Emission Limits**

Emissions radiated outside of the specified frequency bands, except for harmonics, shall be attenuated by at least 50dB below the level of the fundamental or to the general radiated emission limits in paragraph 15.209, whichever is the lesser attenuation.

FCC Part 15 Subpart C Paragraph 15.209(a) Limits		
Frequency MHz	Field strength (microvolts/meter)	Measurement distance (meter)
0.009-0.490	2400/F(kHz)	300
0.490-1.705	24000/F(kHz)	30
1.705-30	30	30
30-88	100	3
88-216	150	3
216-960	200	3
Above 960	500	3

Remarks: E field strength (dBµV /m) = 20 log E field strength (uV/m)

As shown in 15.35(b), on any frequency above 1000 MHz, the radiated emission limits are based on the use of measurement instrumentation employing an average detector function. Unless otherwise specified the limit on peak radio frequency emissions is 20 dB above the maximum permitted average emission limit applicable to the equipment under test.

3.3. Test Procedure

The EUT was setup according to ANSI C63.10, 2013 and tested compliance to FCC 47CFR 15.249 requirements.

Measuring the frequency range below 1GHz, the EUT is placed on a turn table which is 0.8 meter above ground, when measuring the frequency range above 1GHz, the EUT is placed on a turn table which is 1.5 meter above ground.

The turn table is rotated 360 degrees to determine the position of the maximum emission level.

The EUT was positioned such that the distance from antenna to the EUT was 3 meters.

The antenna is scanned between 1 meter and 4 meters to find out the maximum emission level. This is repeated for both horizontal and vertical polarization of the antenna. In order to find the maximum emission, all of the interface cables were manipulated according to ANSI C63.10: 2013 on radiated measurement.

The resolution bandwidth below 30MHz setting on the field strength meter is 9kHz and 30MHz~1GHz is 120kHz and above 1GHz is 1MHz.

Radiated emission measurements below 30MHz are made using Loop Antenna and 30MHz~1GHz are made using broadband Bi-log antenna and above 1GHz are made using Horn Antennas.

The measurement is divided into the Preliminary Measurement and the Final Measurement.

The suspected frequencies are searched for in Preliminary Measurement with the measurement antenna kept pointed at the source of the emission both in azimuth and elevation, with the polarization of the antenna oriented for maximum response. The antenna is pointed at an angle towards the source of the emission, and the EUT is rotated in both height and polarization to maximize the measured emission. The emission is kept within the illumination area of the 3 dB bandwidth of the antenna.

The measurement frequency range from 9kHz - 10th Harmonic of fundamental was investigated.

3.4. Test Result of Radiated Emission

Site :HY-CB02
 Condition :3m ,HORIZONTAL
 mode :TX_Fundamental_X
 Test by :Rock

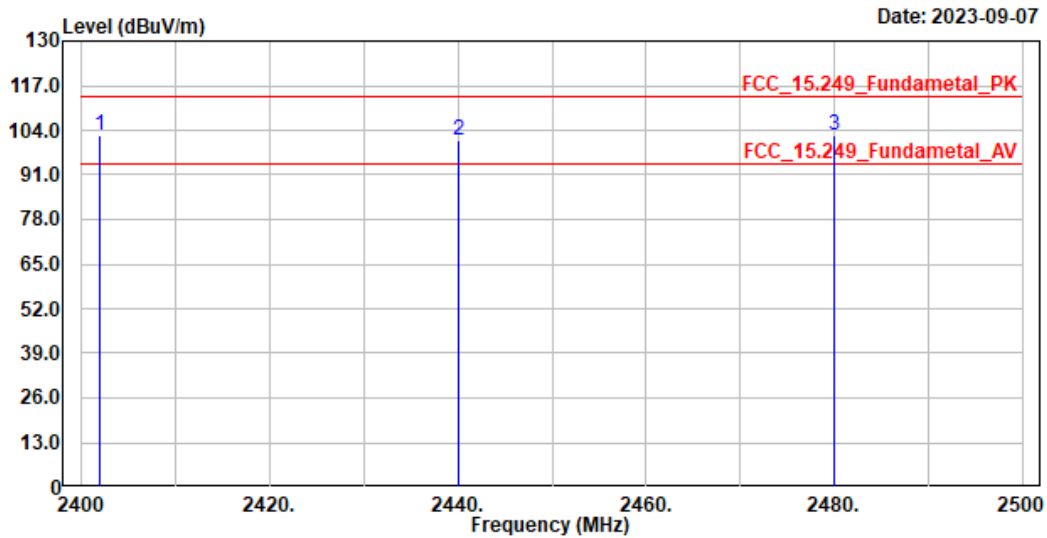

No.	Frequency	Level	Limit	Over	Read	Factor	Remark
	MHz	dBuV/m	dBuV/m	dB	dBuV	dB	
1	2402.000	102.56	113.97	-11.41	95.83	6.73	Peak
2	2440.000	101.22	113.97	-12.75	94.39	6.83	Peak
3	2480.000	102.52	113.97	-11.45	95.62	6.90	Peak

Note:

1. Level = Read Level + Factor
2. Factor = Antenna Factor + Cable Loss - Preamp Factor
3. Over Limit = Level - Limit Line
4. The emission levels of other frequencies are very lower than the limit and not show in test report.

Right

Frequency (MHz)	Peak Measurement (dBμV/m)	Duty Cycle Factor (dB)	Average Measurement (dBμV/m)	Margin (dB)	Average Limit (dBμV/m)
2402	102.56	-20.915	81.645	-12.325	93.970
2440	101.22	-20.915	80.305	-13.665	93.970
2480	102.52	-20.915	81.605	-12.365	93.970

Note:

1. Average Measurement=Peak Measurement + Duty Cycle Factor
2. The Duty Cycle is refer to section 5.

Site :HY-CB02
 Condition :3m ,VERTICAL
 mode :TX_Fundamental_X
 Test by :Rock

Date: 2023-09-08

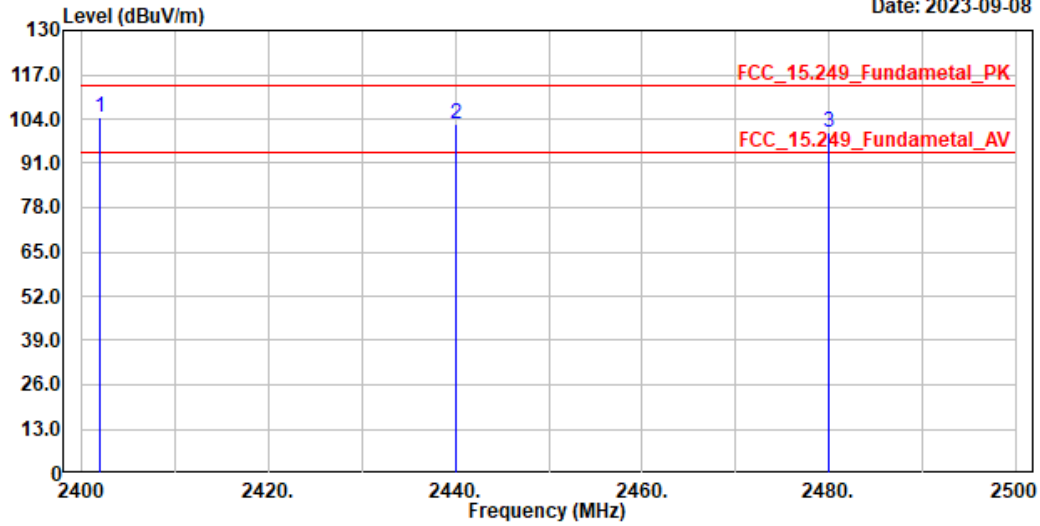

No.	Frequency	Level	Limit	Over	Read	Factor	Remark
	MHz	dBuV/m	Line	Limit	Level		
	MHz	dBuV/m	dBuV/m	dB	dBuV	dB	
1	2402.000	104.34	113.97	-9.63	97.61	6.73	Peak
2	2440.000	102.52	113.97	-11.45	95.69	6.83	Peak
3	2480.000	100.23	113.97	-13.74	93.33	6.90	Peak

Note:

1. Level = Read Level + Factor
2. Factor = Antenna Factor + Cable Loss - Preamp Factor
3. Over Limit = Level - Limit Line
4. The emission levels of other frequencies are very lower than the limit and not show in test report.

Right

Frequency (MHz)	Peak Measurement (dBuV/m)	Duty Cycle Factor (dB)	Average Measurement (dBuV/m)	Margin (dB)	Average Limit (dBuV/m)
2402	104.34	-20.915	83.425	-10.545	93.970
2440	102.52	-20.915	81.605	-12.365	93.970
2480	102.23	-20.915	81.315	-12.655	93.970

Note:

1. Average Measurement=Peak Measurement + Duty Cycle Factor
2. The Duty Cycle is refer to section 5.

Site :HY-CB02
 Condition :3m ,HORIZONTAL
 mode :TX_Fundamental_Y
 Test by :Rock

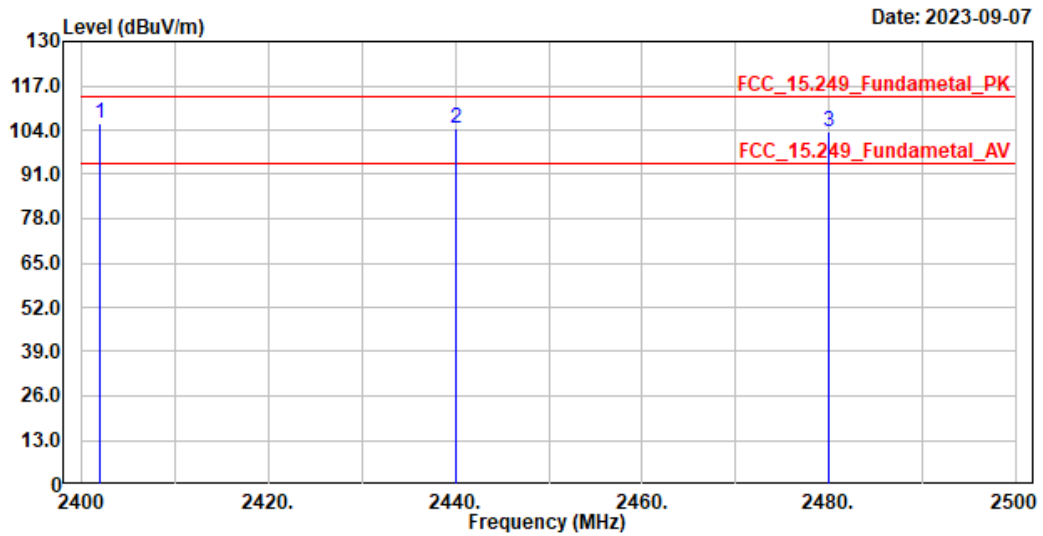

Date: 2023-09-07

No.	Frequency	Level	Limit Line	Over Limit	Read Level	Factor	Remark
	MHz	dBuV/m	dBuV/m	dB	dBuV	dB	
1	2402.000	106.10	113.97	-7.87	99.37	6.73	Peak
2	2440.000	104.37	113.97	-9.60	97.54	6.83	Peak
3	2480.000	103.31	113.97	-10.66	96.41	6.90	Peak

Note:

1. Level = Read Level + Factor
2. Factor = Antenna Factor + Cable Loss - Preamp Factor
3. Over Limit = Level - Limit Line
4. The emission levels of other frequencies are very lower than the limit and not show in test report.

Right

Frequency (MHz)	Peak Measurement (dBμV/m)	Duty Cycle Factor (dB)	Average Measurement (dBμV/m)	Margin (dB)	Average Limit (dBμV/m)
2402	106.1	-20.915	85.185	-8.785	93.970
2440	104.37	-20.915	83.455	-10.515	93.970
2480	103.31	-20.915	82.395	-11.575	93.970

Note:

1. Average Measurement=Peak Measurement + Duty Cycle Factor
2. The Duty Cycle is refer to section 5.

Site :HY-CB02
 Condition :3m ,VERTICAL
 mode :TX_Fundamental_Y
 Test by :Rock

Date: 2023-09-07

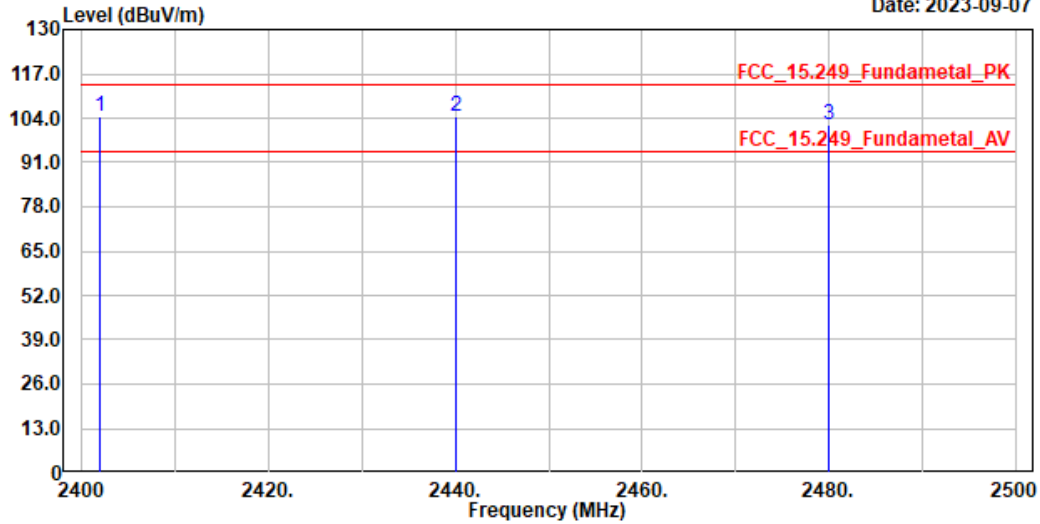

No.	Frequency	Level	Limit Line	Over Limit	Read Level	Factor	Remark
	MHz	dBuV/m	dBuV/m	dB	dBuV	dB	
1	2402.000	104.27	113.97	-9.70	97.54	6.73	Peak
2	2440.000	104.25	113.97	-9.72	97.42	6.83	Peak
3	2480.000	101.85	113.97	-12.12	94.95	6.90	Peak

Note:

1. Level = Read Level + Factor
2. Factor = Antenna Factor + Cable Loss - Preamp Factor
3. Over Limit = Level - Limit Line
4. The emission levels of other frequencies are very lower than the limit and not show in test report.

Right

Frequency (MHz)	Peak Measurement (dBμV/m)	Duty Cycle Factor (dB)	Average Measurement (dBμV/m)	Margin (dB)	Average Limit (dBμV/m)
2402	104.27	-20.915	83.355	-10.615	93.970
2440	104.25	-20.915	83.335	-10.635	93.970
2480	101.85	-20.915	80.935	-13.035	93.970

Note:

1. Average Measurement=Peak Measurement + Duty Cycle Factor
2. The Duty Cycle is refer to section 5.

Site :HY-CB02
 Condition :3m ,HORIZONTAL
 mode :TX_Fundamental_Z
 Test by :Rock

Date: 2023-09-07

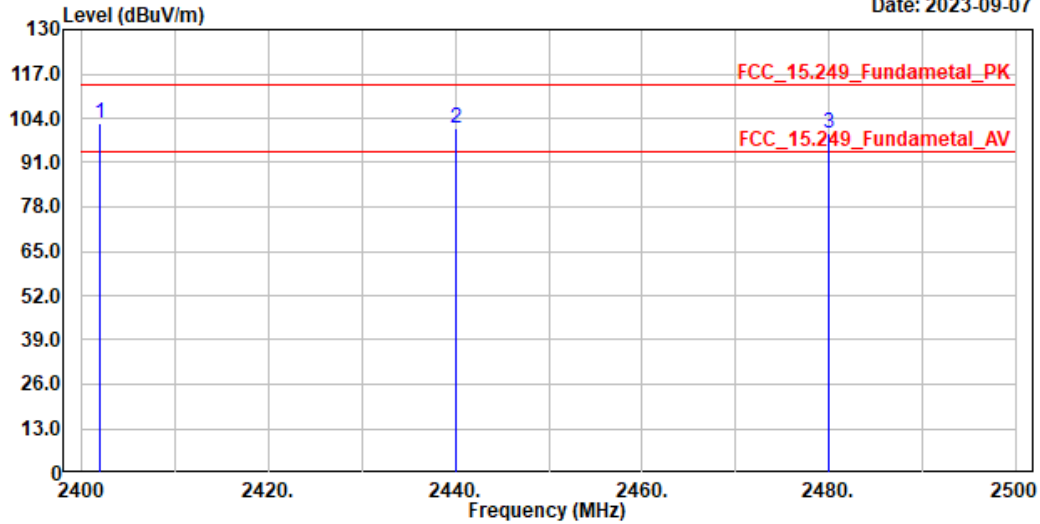

No.	Frequency	Level	Limit	Over	Read	Factor	Remark
	MHz	dBuV/m	dBuV/m	dB	dBuV	dB	
1	2402.000	102.64	113.97	-11.33	95.91	6.73	Peak
2	2440.000	101.17	113.97	-12.80	94.34	6.83	Peak
3	2480.000	99.56	113.97	-14.41	92.66	6.90	Peak

Note:

1. Level = Read Level + Factor
2. Factor = Antenna Factor + Cable Loss - Preamp Factor
3. Over Limit = Level - Limit Line
4. The emission levels of other frequencies are very lower than the limit and not show in test report.

Right

Frequency (MHz)	Peak Measurement (dBμV/m)	Duty Cycle Factor (dB)	Average Measurement (dBμV/m)	Margin (dB)	Average Limit (dBμV/m)
2402	102.64	-20.915	81.725	-12.245	93.970
2440	101.17	-20.915	80.255	-13.715	93.970
2480	99.56	-20.915	78.645	-15.325	93.970

Note:

1. Average Measurement=Peak Measurement + Duty Cycle Factor
2. The Duty Cycle is refer to section 5.

Site :HY-CB02
 Condition :3m ,VERTICAL
 mode :TX_Fundamental_Z
 Test by :Rock

Date: 2023-09-08

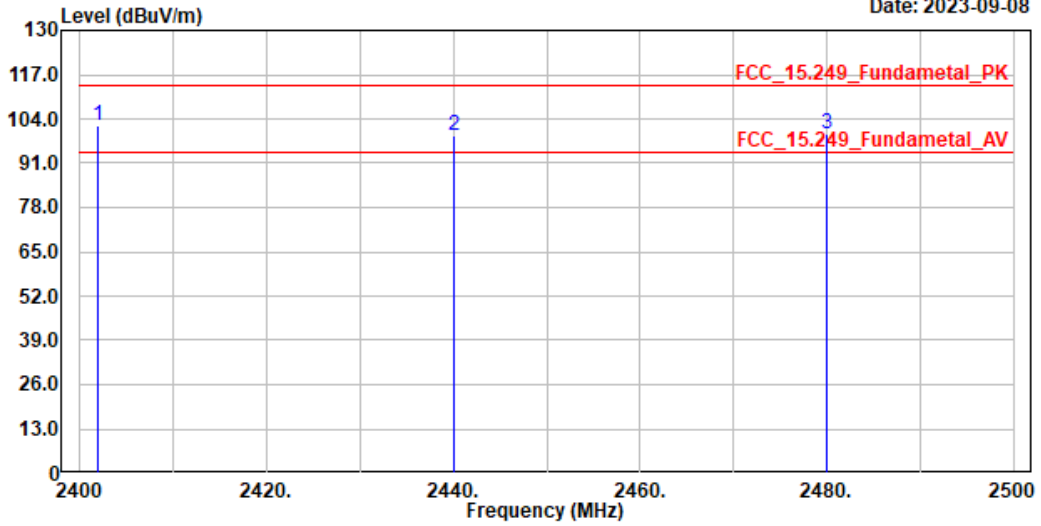

No.	Frequency	Level	Limit	Over	Read	Factor	Remark
	MHz	dBuV/m	Line	Limit	Level		
	MHz	dBuV/m	dBuV/m	dB	dBuV	dB	
1	2402.000	101.84	113.97	-12.13	95.11	6.73	Peak
2	2440.000	99.15	113.97	-14.82	92.32	6.83	Peak
3	2480.000	99.43	113.97	-14.54	92.53	6.90	Peak

Note:

1. Level = Read Level + Factor
2. Factor = Antenna Factor + Cable Loss - Preamp Factor
3. Over Limit = Level - Limit Line
4. The emission levels of other frequencies are very lower than the limit and not show in test report.

Right

Frequency (MHz)	Peak Measurement (dBμV/m)	Duty Cycle Factor (dB)	Average Measurement (dBμV/m)	Margin (dB)	Average Limit (dBμV/m)
2402	101.84	-20.915	80.925	-13.045	93.970
2440	99.15	-20.915	78.235	-15.735	93.970
2480	99.43	-20.915	78.515	-15.455	93.970

Note:

1. Average Measurement=Peak Measurement + Duty Cycle Factor
2. The Duty Cycle is refer to section 5.

Site :HY-CB02
 Condition :3m ,Horizontal
 mode :TX_Fundamental_X
 Test by :Nova

Date: 2023-09-08

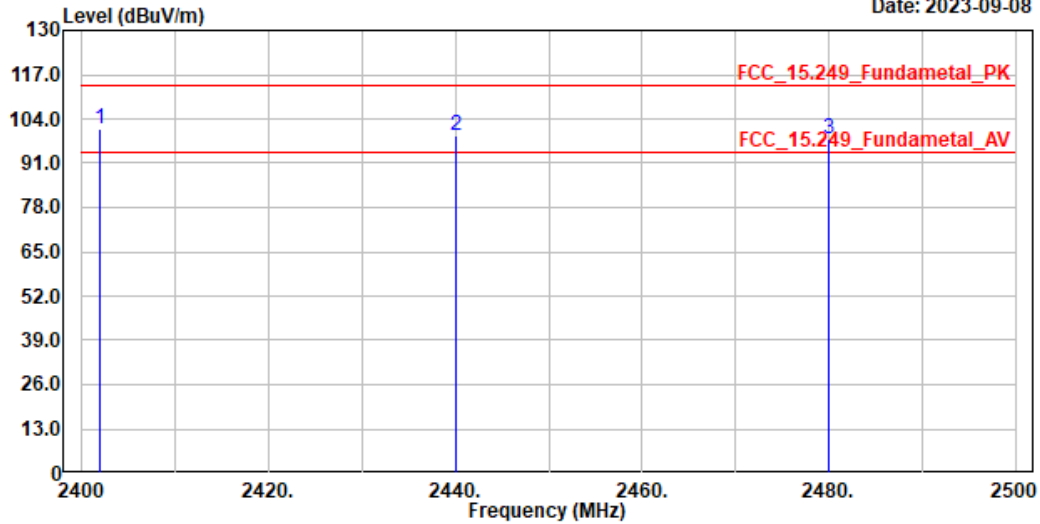

No.	Frequency	Level	Limit	Over	Read	Factor	Remark
	MHz	dBuV/m	dBuV/m	dB	dBuV	dB	
1	2402.000	100.85	113.97	-13.12	94.12	6.73	Peak
2	2440.000	99.33	113.97	-14.64	92.50	6.83	Peak
3	2480.000	98.26	113.97	-15.71	91.36	6.90	Peak

Note:

1. Level = Read Level + Factor
2. Factor = Antenna Factor + Cable Loss - Preamp Factor
3. Over Limit = Level - Limit Line
4. The emission levels of other frequencies are very lower than the limit and not show in test report.

Left

Frequency (MHz)	Peak Measurement (dBμV/m)	Duty Cycle Factor (dB)	Average Measurement (dBμV/m)	Margin (dB)	Average Limit (dBμV/m)
2402	100.85	-20.915	79.935	-14.035	93.970
2440	99.33	-20.915	78.415	-15.555	93.970
2480	98.26	-20.915	77.345	-16.625	93.970

Note:

1. Average Measurement=Peak Measurement + Duty Cycle Factor
2. The Duty Cycle is refer to section 5.

Site :HY-CB02
 Condition :3m ,VERTICAL
 mode :TX_Fundamental_X
 Test by :Nova

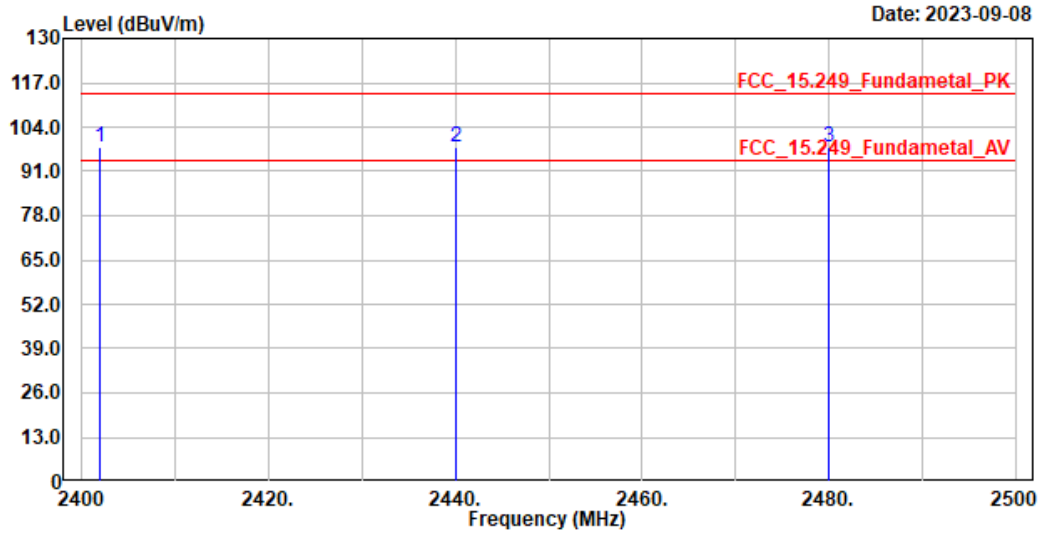

Date: 2023-09-08

No.	Frequency	Level	Limit Line	Over Limit	Read Level	Factor	Remark
	MHz	dBuV/m	dBuV/m	dB	dBuV	dB	
1	2402.000	98.14	113.97	-15.83	91.41	6.73	Peak
2	2440.000	98.05	113.97	-15.92	91.22	6.83	Peak
3	2480.000	98.10	113.97	-15.87	91.20	6.90	Peak

Note:

1. Level = Read Level + Factor
2. Factor = Antenna Factor + Cable Loss - Preamp Factor
3. Over Limit = Level - Limit Line
4. The emission levels of other frequencies are very lower than the limit and not show in test report.

Left

Frequency (MHz)	Peak Measurement (dBμV/m)	Duty Cycle Factor (dB)	Average Measurement (dBμV/m)	Margin (dB)	Average Limit (dBμV/m)
2402	98.14	-20.915	77.225	-16.745	93.970
2440	98.05	-20.915	77.135	-16.835	93.970
2480	98.1	-20.915	77.185	-16.785	93.970

Note:

1. Average Measurement=Peak Measurement + Duty Cycle Factor
2. The Duty Cycle is refer to section 5.

Site :HY-CB02
 Condition :3m ,Horizontal
 mode :TX_Fundamental_Y
 Test by :Rock

Date: 2023-09-07

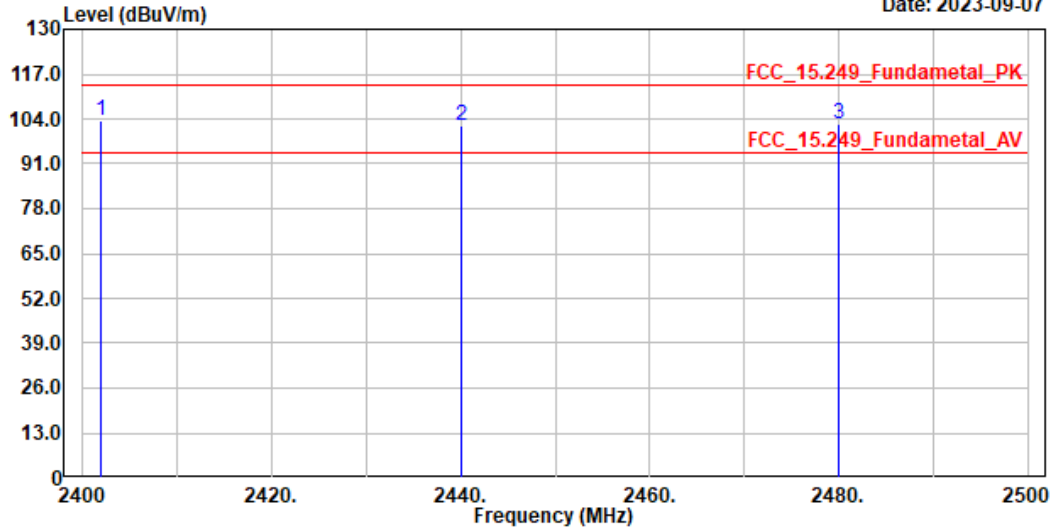

No.	Frequency	Level	Limit Line	Over Limit	Read Level	Factor	Remark
	MHz	dBuV/m	dBuV/m	dB	dBuV	dB	
1	2402.000	103.44	113.97	-10.53	96.71	6.73	Peak
2	2440.000	101.83	113.97	-12.14	95.00	6.83	Peak
3	2480.000	102.31	113.97	-11.66	95.41	6.90	Peak

Note:

1. Level = Read Level + Factor
2. Factor = Antenna Factor + Cable Loss - Preamp Factor
3. Over Limit = Level - Limit Line
4. The emission levels of other frequencies are very lower than the limit and not show in test report.

Left

Frequency (MHz)	Peak Measurement (dBuV/m)	Duty Cycle Factor (dB)	Average Measurement (dBuV/m)	Margin (dB)	Average Limit (dBuV/m)
2402	103.44	-20.915	82.525	-11.445	93.970
2440	101.83	-20.915	80.915	-13.055	93.970
2480	102.31	-20.915	81.395	-12.575	93.970

Note:

1. Average Measurement=Peak Measurement + Duty Cycle Factor
2. The Duty Cycle is refer to section 5.

Site :HY-CB02
 Condition :3m ,VERTICAL
 mode :TX_Fundamental_Y
 Test by :Rock

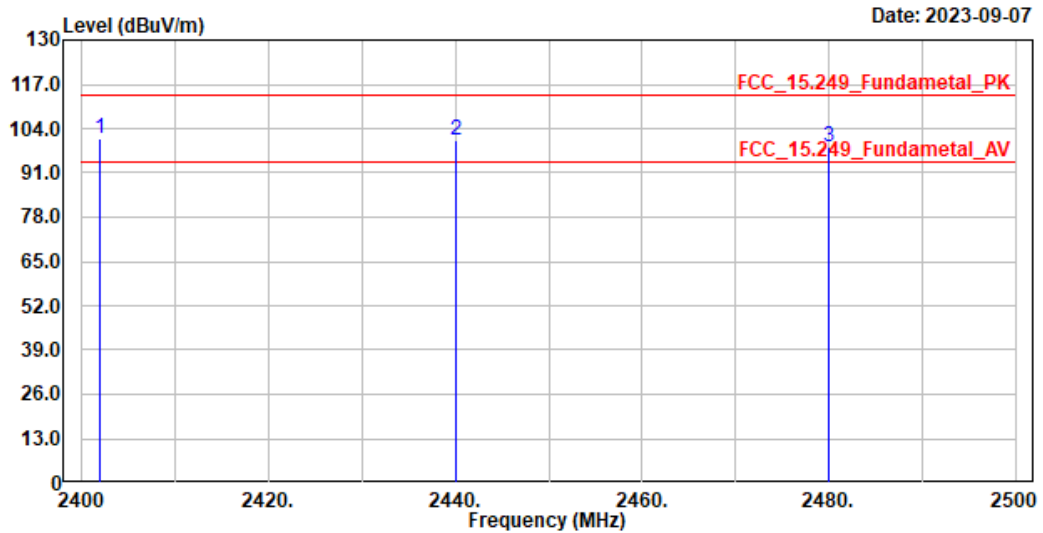

No.	Frequency	Level	Limit Line	Over Limit	Read Level	Factor	Remark
	MHz	dBuV/m	dBuV/m	dB	dBuV	dB	
1	2402.000	100.90	113.97	-13.07	94.17	6.73	Peak
2	2440.000	100.40	113.97	-13.57	93.57	6.83	Peak
3	2480.000	98.78	113.97	-15.19	91.88	6.90	Peak

Note:

1. Level = Read Level + Factor
2. Factor = Antenna Factor + Cable Loss - Preamp Factor
3. Over Limit = Level - Limit Line
4. The emission levels of other frequencies are very lower than the limit and not show in test report.

Left

Frequency (MHz)	Peak Measurement (dBμV/m)	Duty Cycle Factor (dB)	Average Measurement (dBμV/m)	Margin (dB)	Average Limit (dBμV/m)
2402	100.9	-20.915	79.985	-13.985	93.970
2440	100.4	-20.915	79.485	-14.485	93.970
2480	98.78	-20.915	77.865	-16.105	93.970

Note:

1. Average Measurement=Peak Measurement + Duty Cycle Factor
2. The Duty Cycle is refer to section 5.

Site :HY-CB02
 Condition :3m ,Horizontal
 mode :TX_Fundamental_Z
 Test by :Nova

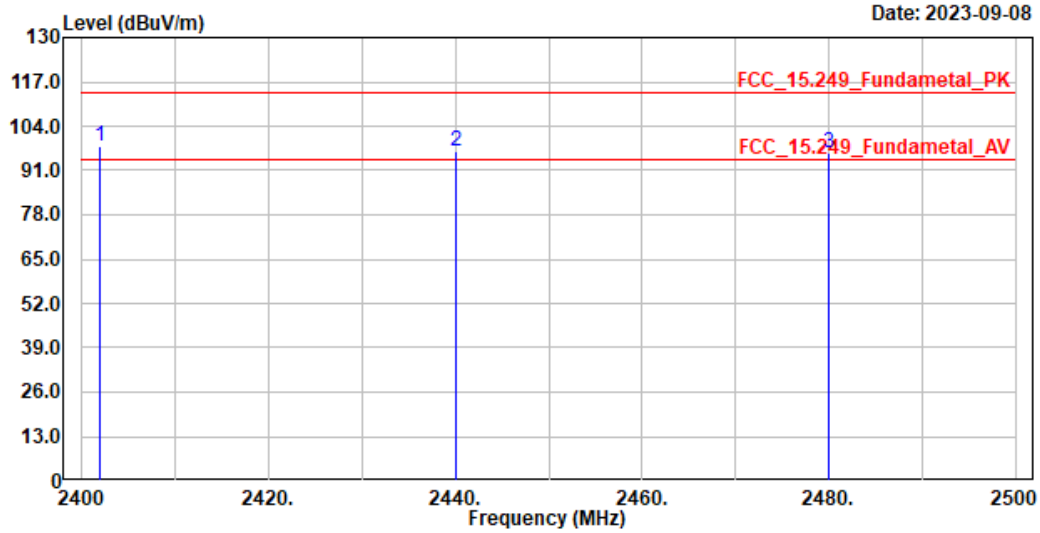

No.	Frequency	Level	Limit Line	Over Limit	Read Level	Factor	Remark
	MHz	dBuV/m	dBuV/m	dB	dBuV	dB	
1	2402.000	98.13	113.97	-15.84	91.40	6.73	Peak
2	2440.000	96.74	113.97	-17.23	89.91	6.83	Peak
3	2480.000	96.01	113.97	-17.96	89.11	6.90	Peak

Note:

1. Level = Read Level + Factor
2. Factor = Antenna Factor + Cable Loss - Preamp Factor
3. Over Limit = Level - Limit Line
4. The emission levels of other frequencies are very lower than the limit and not show in test report.

Left

Frequency (MHz)	Peak Measurement (dBμV/m)	Duty Cycle Factor (dB)	Average Measurement (dBμV/m)	Margin (dB)	Average Limit (dBμV/m)
2402	98.13	-20.915	77.215	-16.755	93.970
2440	96.74	-20.915	75.825	-18.145	93.970
2480	96.01	-20.915	75.095	-18.875	93.970

Note:

1. Average Measurement=Peak Measurement + Duty Cycle Factor
2. The Duty Cycle is refer to section 5.

Site :HY-CB02
 Condition :3m ,VERTICAL
 mode :TX_Fundamental_Z
 Test by :Rock

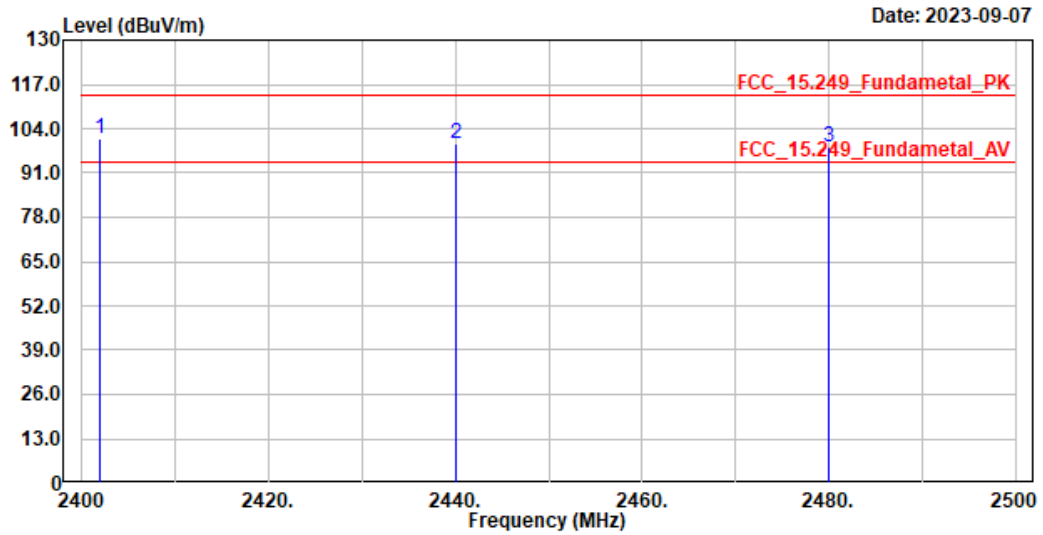

Date: 2023-09-07

No.	Frequency	Level	Limit Line	Over Limit	Read Level	Factor	Remark
	MHz	dBuV/m	dBuV/m	dB	dBuV	dB	
1	2402.000	101.05	113.97	-12.92	94.32	6.73	Peak
2	2440.000	99.42	113.97	-14.55	92.59	6.83	Peak
3	2480.000	98.43	113.97	-15.54	91.53	6.90	Peak

Note:

1. Level = Read Level + Factor
2. Factor = Antenna Factor + Cable Loss - Preamp Factor
3. Over Limit = Level - Limit Line
4. The emission levels of other frequencies are very lower than the limit and not show in test report.

Left

Frequency (MHz)	Peak Measurement (dBμV/m)	Duty Cycle Factor (dB)	Average Measurement (dBμV/m)	Margin (dB)	Average Limit (dBμV/m)
2402	101.05	-20.915	80.135	-13.835	93.970
2440	99.42	-20.915	78.505	-15.465	93.970
2480	98.43	-20.915	77.515	-16.455	93.970

Note:

1. Average Measurement=Peak Measurement + Duty Cycle Factor
2. The Duty Cycle is refer to section 5.

Right

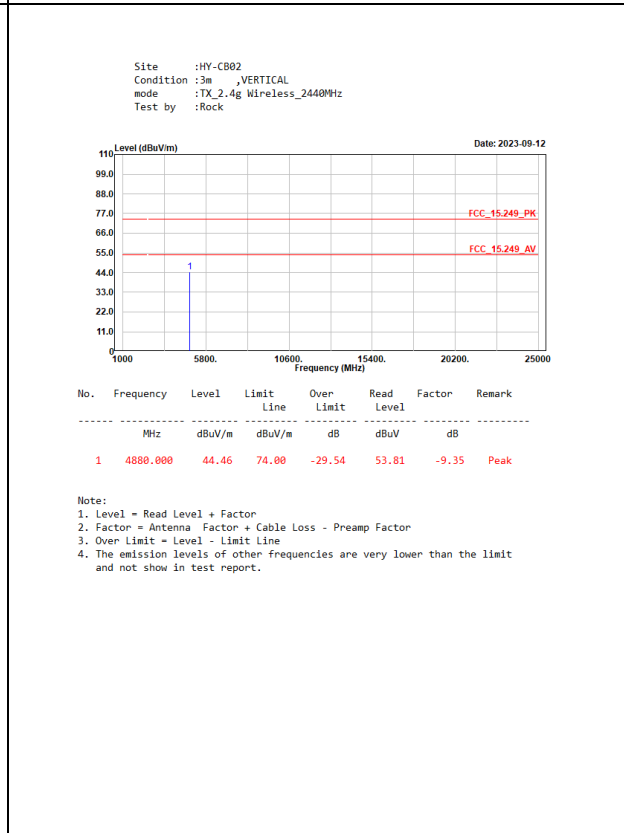
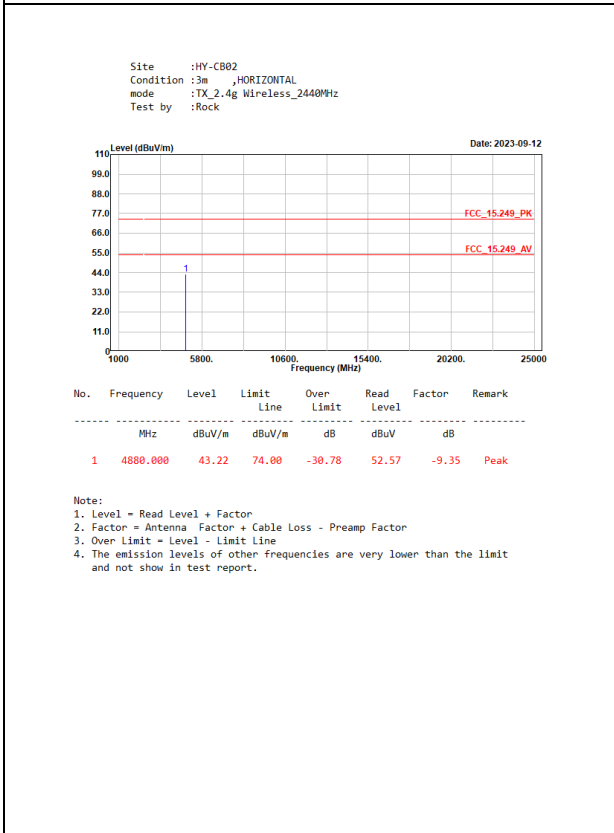
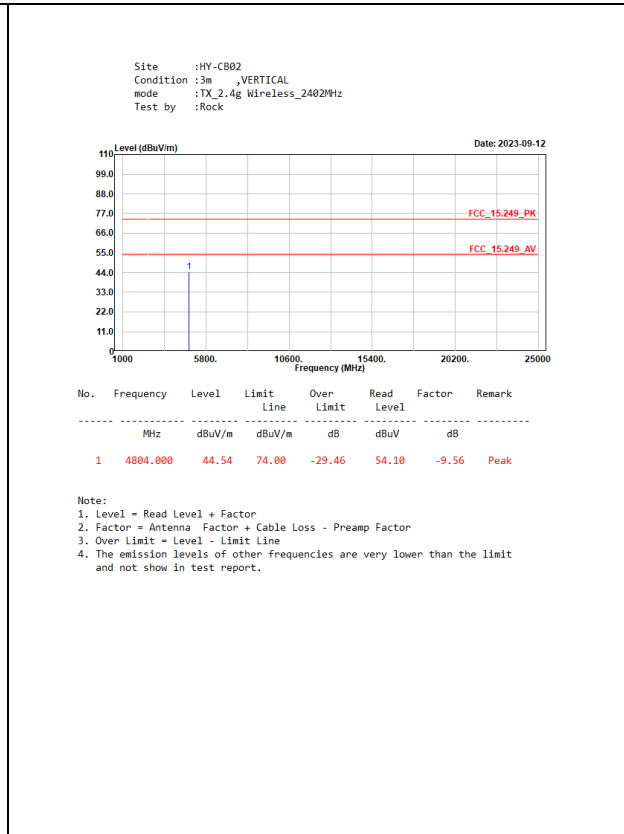
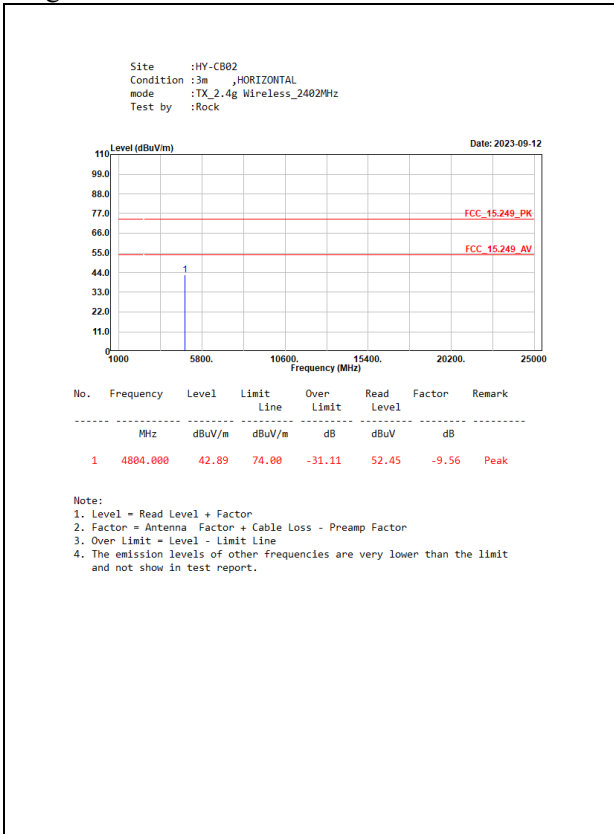

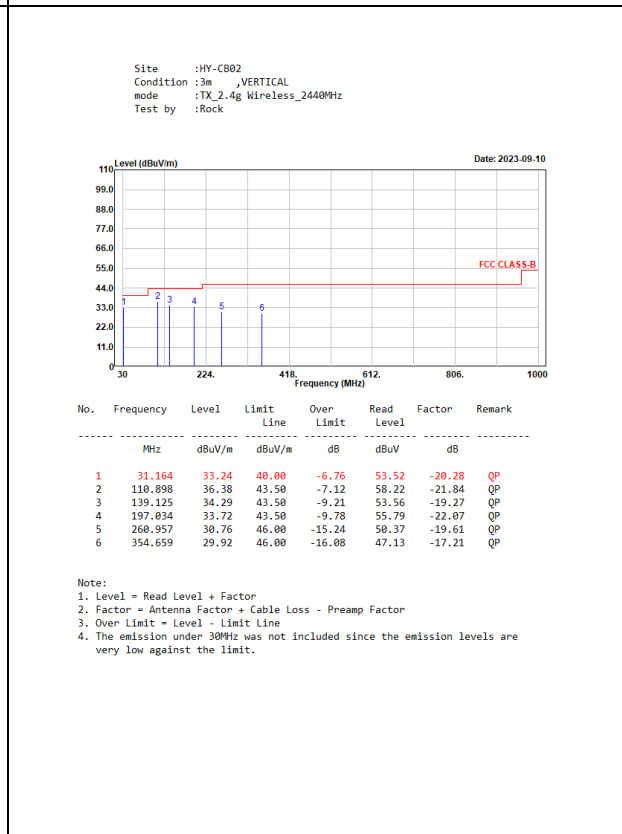
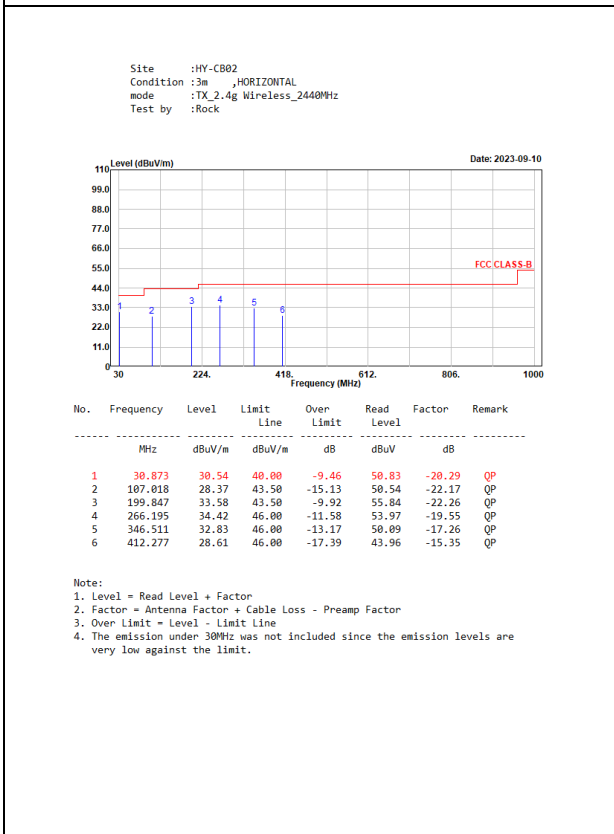
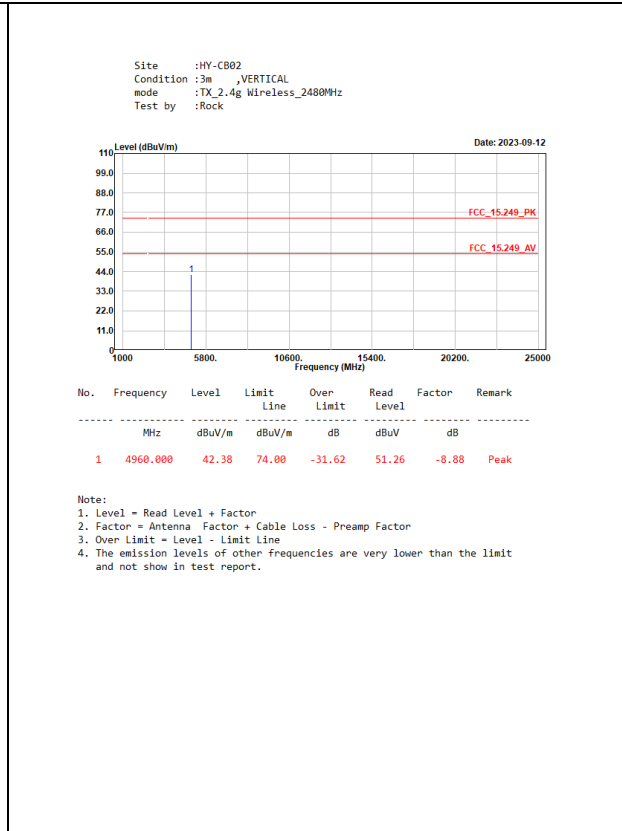
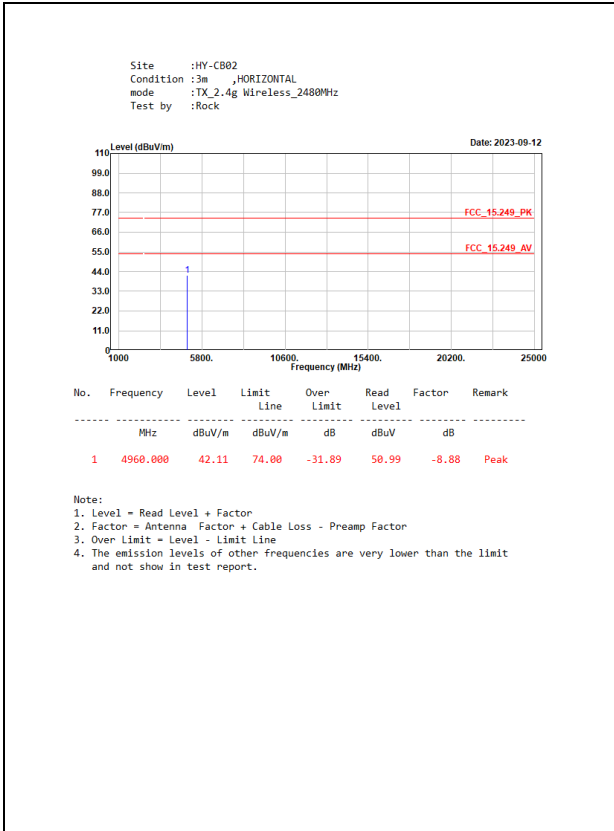

Left

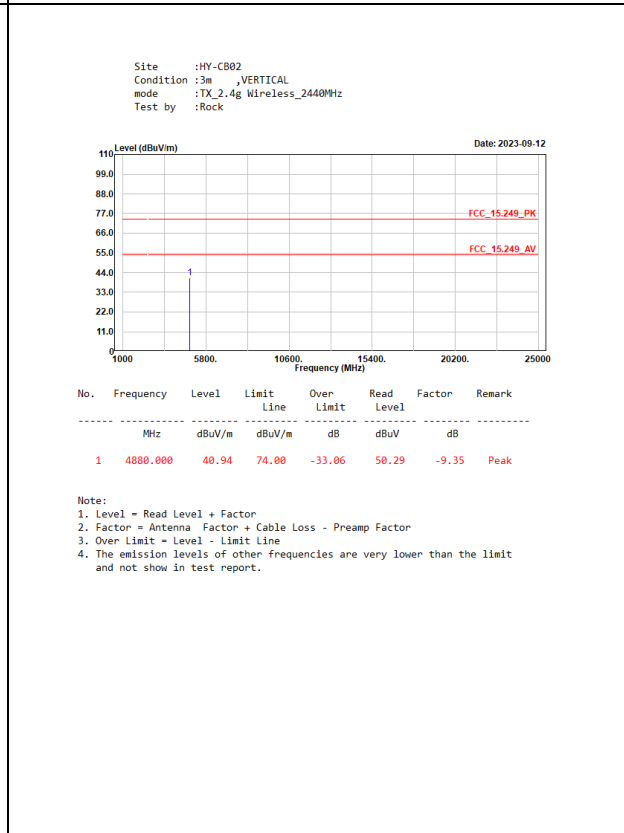
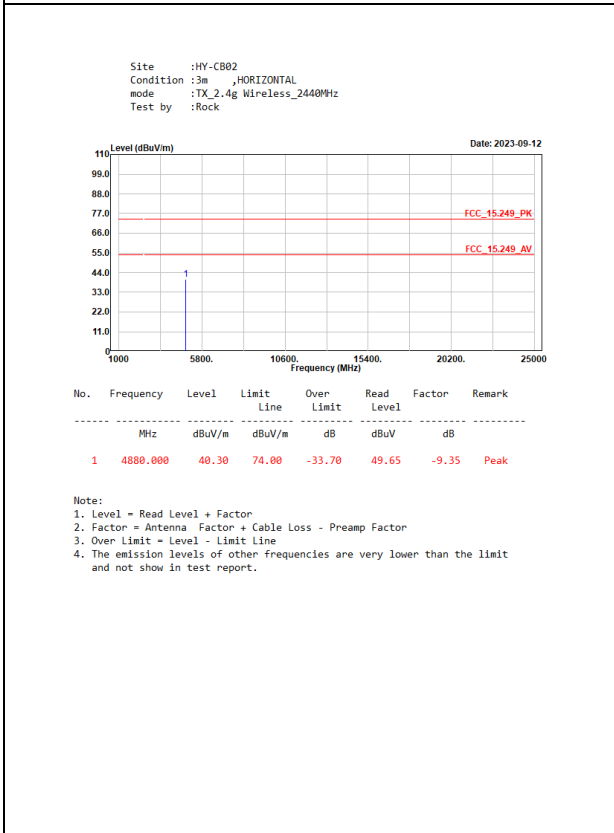
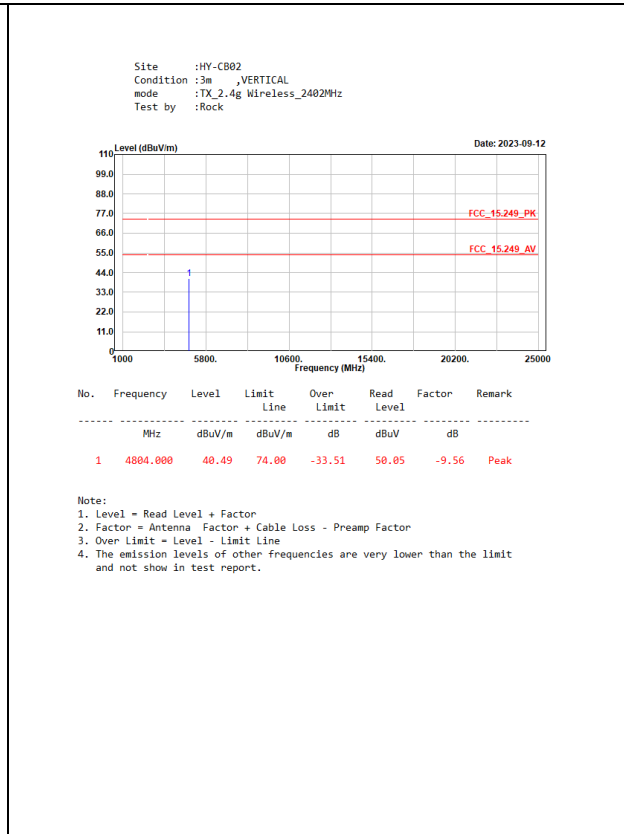
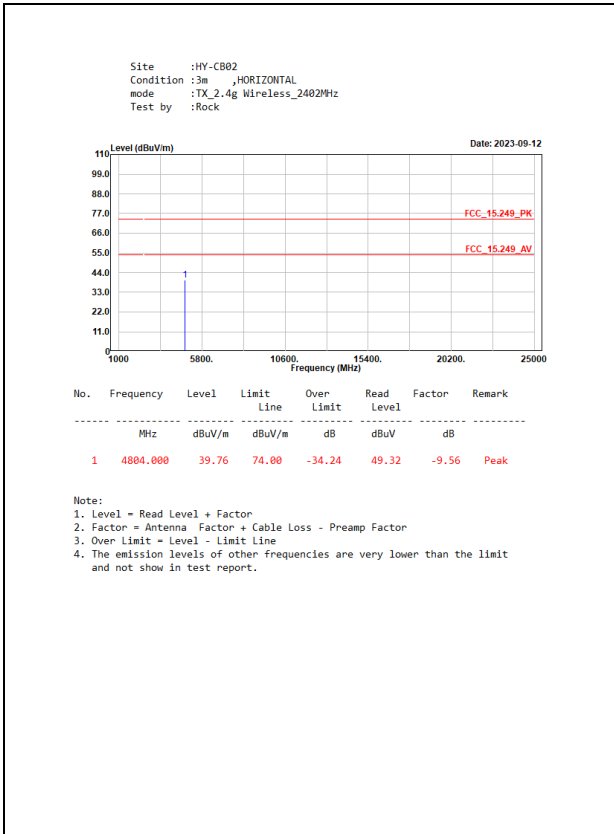

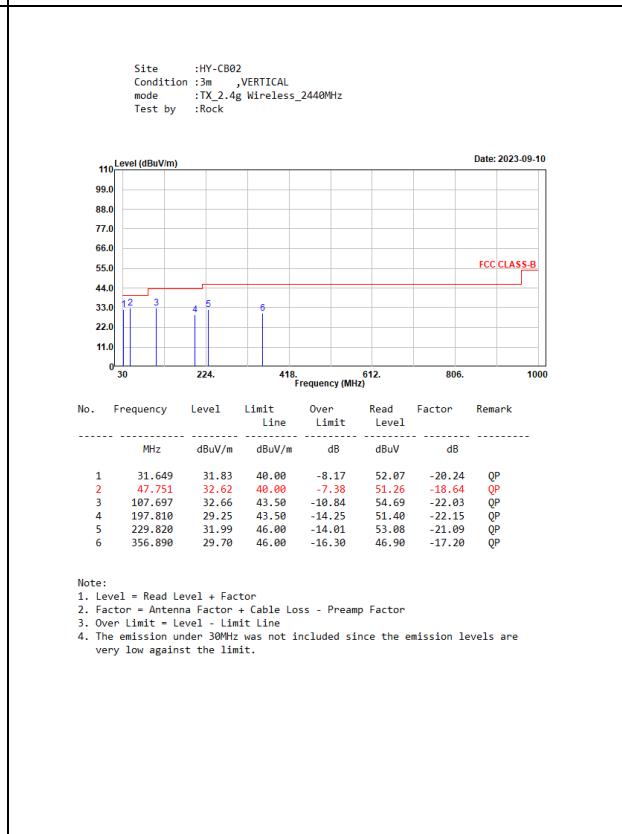
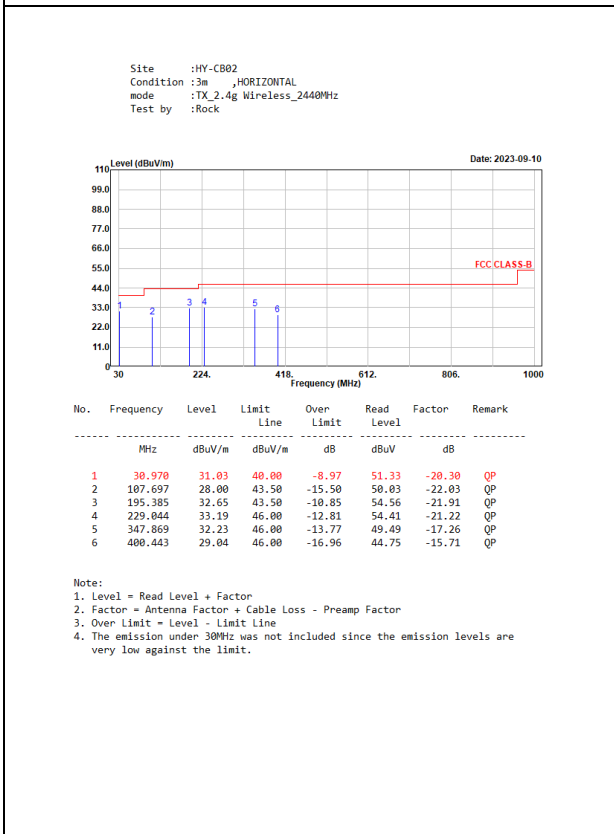
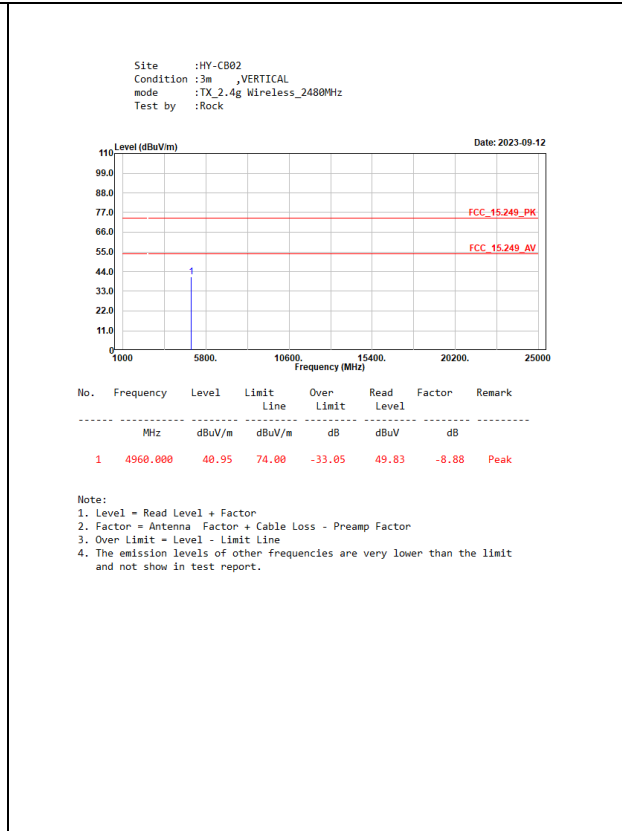
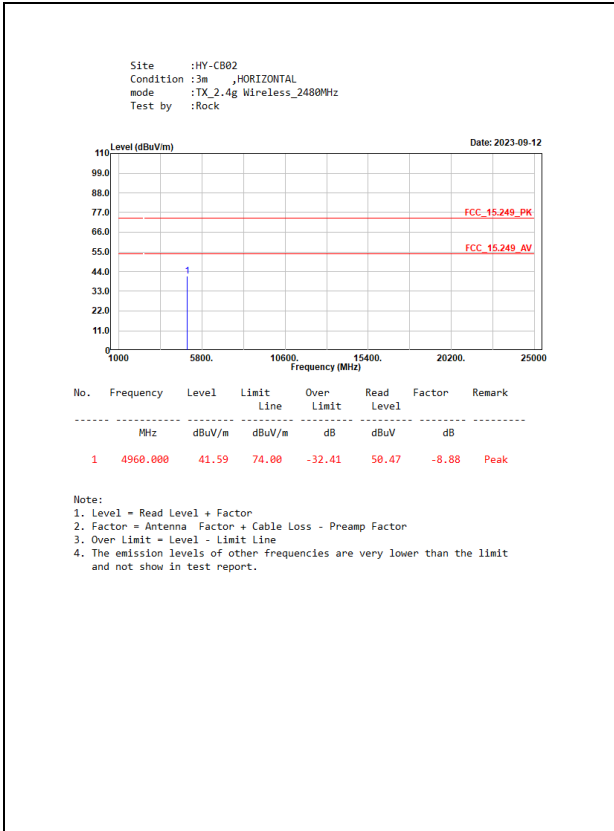

4. Band Edge

4.1. Test Setup

RF Radiated Measurement:

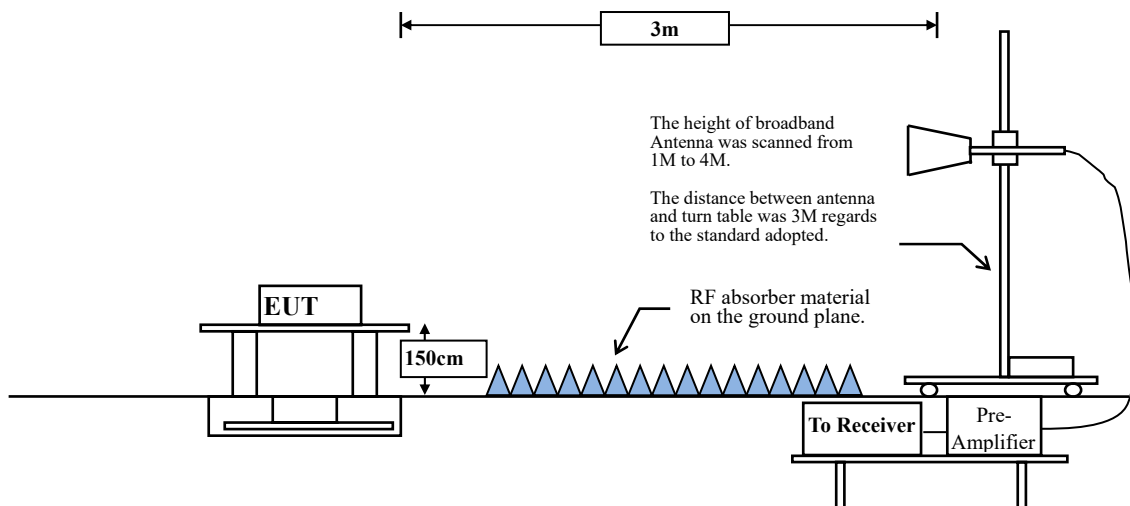

4.2. Limits

Emissions radiated outside of the specified frequency bands, except for harmonics, shall be attenuated by at least 50dB below the level of the fundamental or to the general radiated emission limits in paragraph 15.209, whichever is the lesser attenuation.

FCC Part 15 Subpart C Paragraph 15.209(a) Limits		
Frequency MHz	Field strength (microvolts/meter)	Measurement distance (meter)
0.009-0.490	2400/F(kHz)	300
0.490-1.705	24000/F(kHz)	30
1.705-30	30	30
30-88	100	3
88-216	150	3
216-960	200	3
Above 960	500	3

Remarks: E field strength (dB μ V /m) = 20 log E field strength (uV/m)

4.3. Test Procedure

The EUT is placed on a turn table which is 1.5 meter above ground. The turn table is rotated 360 degrees to determine the position of the maximum emission level. The EUT was positioned such that the distance from antenna to the EUT was 3 meters.

The antenna can move up and down between 1 meter and 4 meters to find out the maximum emission level.

Both horizontal and vertical polarization of the antenna are set on measurement. In order to find the maximum emission, all of the interface cables must be manipulated according to ANSI C63.10: 2013 on radiated measurement.

The bandwidth setting below 1GHz and above 1GHz on the field strength meter is 120 kHz and 1MHz, respectively.

4.4. Test Result of Band Edge

Site :HY-CB02
 Condition :3m ,HORIZONTAL
 mode :TX_2.4g Wireless_2402MHz
 Test by :Rock

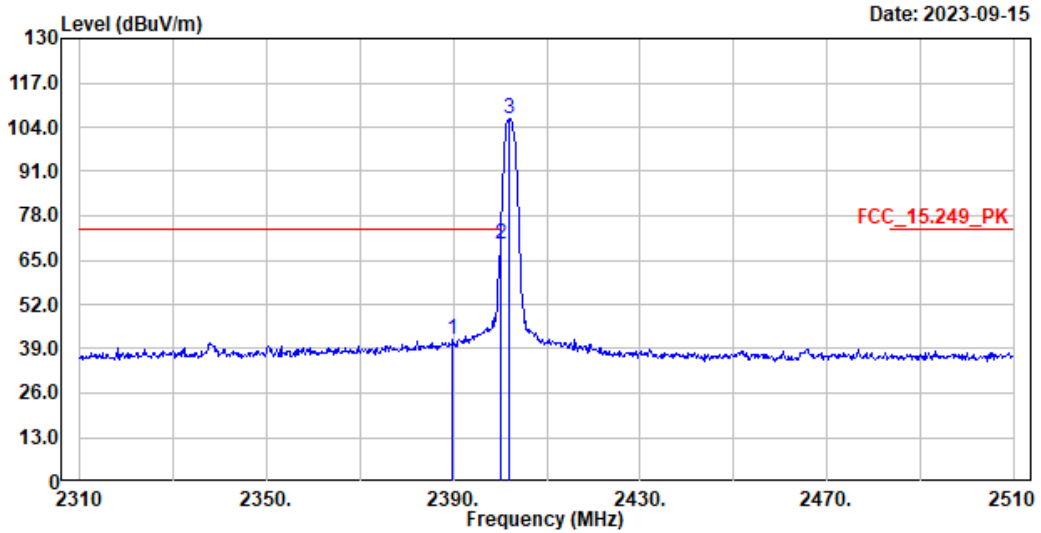

No.	Frequency	Level	Limit	Over	Read	Factor	Remark
	MHz	dBuV/m	dBuV/m	dB	dBuV	dB	
1	2389.800	41.73	74.00	-32.27	34.93	6.80	Peak
2	2400.000	69.86	74.00	-4.14	63.13	6.73	Peak
3	2402.000	106.37	-----	-----	99.64	6.73	Peak

Note:

1. Level = Read Level + Factor
2. Factor = Antenna Factor + Cable Loss - Preamp Factor
3. Over Limit = Level - Limit Line
4. The emission levels of other frequencies are very lower than the limit and not show in test report.

Right

Frequency (MHz)	Peak Measurement (dBμV/m)	Duty Cycle Factor (dB)	Average Measurement (dBμV/m)	Margin (dB)	Average Limit (dBμV/m)	Result
2365	43.23	-20.915	22.315	-31.685	54.000	Pass
2400	71.81	-20.915	50.895	-3.105	54.000	Pass
2402	106.47	-20.915	85.555	--	--	Pass

Note:

1. Average Measurement=Peak Measurement + Duty Cycle Factor
2. The Duty Cycle is refer to section 5.

Site :HY-CB02
 Condition :3m ,Vertical
 mode :TX_2.4g Wireless_2402MHz
 Test by :Rock

Date: 2023-09-15

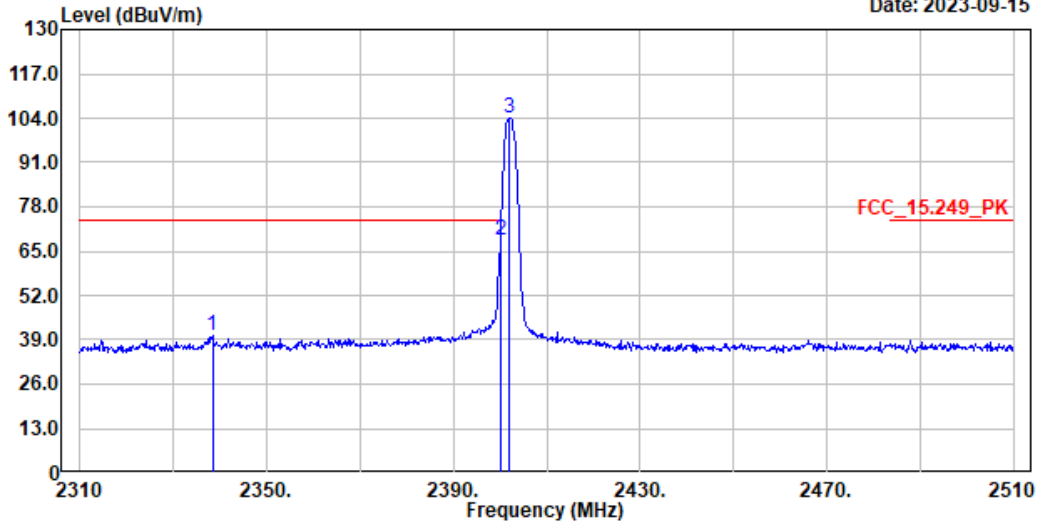

No.	Frequency	Level	Limit	Over	Read	Factor	Remark
	MHz	dBuV/m	dBuV/m	Limit	Level	dB	
1	2338.400	40.04	74.00	-33.96	33.03	7.01	Peak
2	2400.000	68.10	74.00	-5.90	61.37	6.73	Peak
3	2402.000	104.24	-----	-----	97.51	6.73	Peak

Note:

1. Level = Read Level + Factor
2. Factor = Antenna Factor + Cable Loss - Preamp Factor
3. Over Limit = Level - Limit Line
4. The emission levels of other frequencies are very lower than the limit and not show in test report.

Right

Frequency (MHz)	Peak Measurement (dBμV/m)	Duty Cycle Factor (dB)	Average Measurement (dBμV/m)	Margin (dB)	Average Limit (dBμV/m)	Result
2388.6	44.03	-20.915	23.115	-30.885	54.000	Pass
2400	70.62	-20.915	49.705	-4.295	54.000	Pass
2402	104.31	-20.915	83.395	--	--	Pass

Note:

1. Average Measurement=Peak Measurement + Duty Cycle Factor
2. The Duty Cycle is refer to section 5.

Site :HY-CB02
 Condition :3m ,HORIZONTAL
 mode :TX_2.4g Wireless_2480MHz
 Test by :Rock

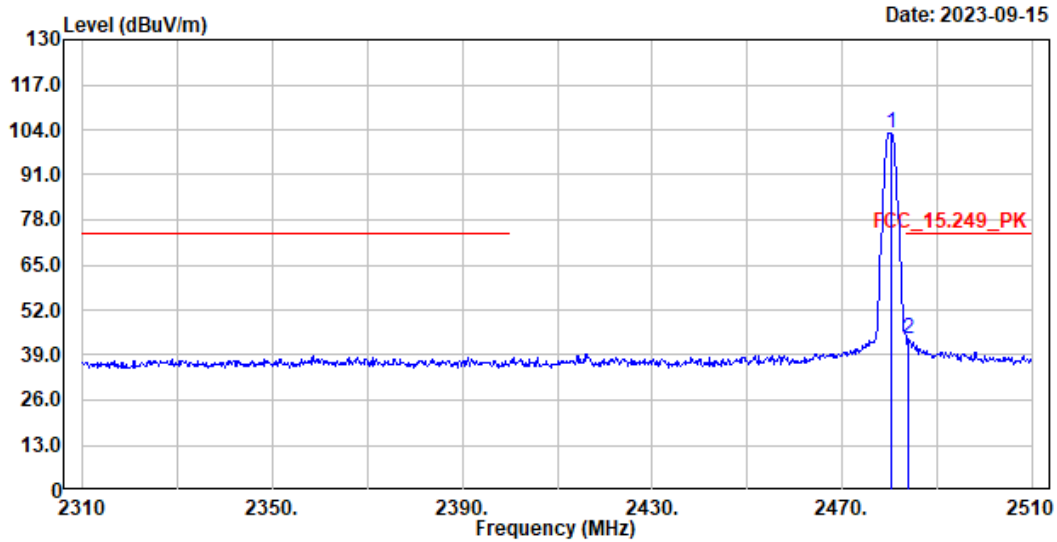

No.	Frequency	Level	Limit	Over	Read	Factor	Remark
	MHz	dBuV/m	dBuV/m	dB	dBuV	dB	
1	2480.200	103.01	-----	-----	96.11	6.90	Peak
2	2484.000	43.44	74.00	-30.56	36.53	6.91	Peak

Note:

1. Level = Read Level + Factor
2. Factor = Antenna Factor + Cable Loss - Preamp Factor
3. Over Limit = Level - Limit Line
4. The emission levels of other frequencies are very lower than the limit and not show in test report.

Right

Frequency (MHz)	Peak Measurement (dBμV/m)	Duty Cycle Factor (dB)	Average Measurement (dBμV/m)	Margin (dB)	Average Limit (dBμV/m)	Result
2480.2	102.18	-20.915	81.265	--	--	Pass
2484.2	43.28	-20.915	22.365	-31.635	54.000	Pass

Note:

1. Average Measurement=Peak Measurement + Duty Cycle Factor
2. The Duty Cycle is refer to section 5.

Site :HY-CB02
 Condition :3m ,Vertical
 mode :TX_2.4g Wireless_2480MHz
 Test by :Rock

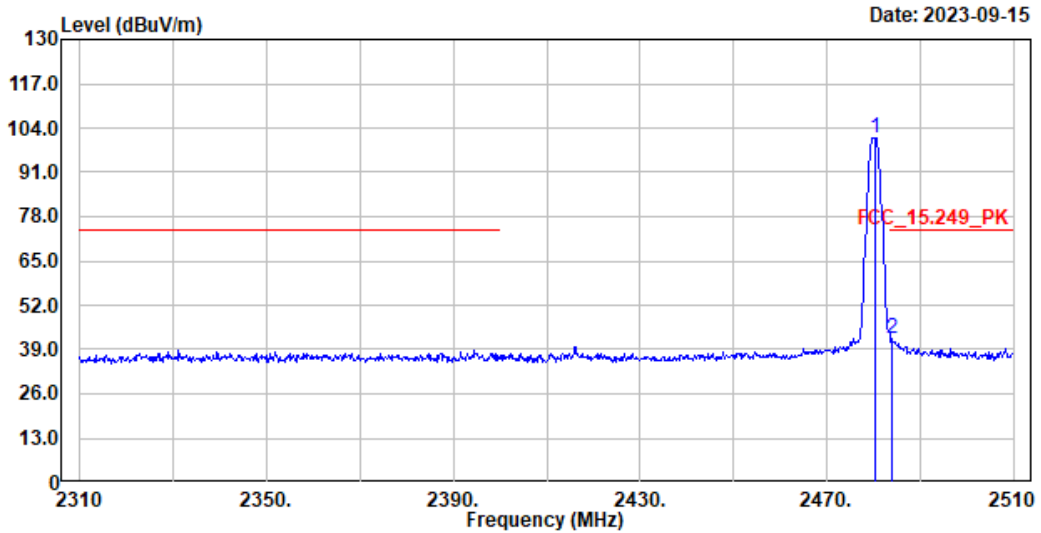

No.	Frequency	Level	Limit Line	Over Limit	Read Level	Factor	Remark
	MHz	dBuV/m	dBuV/m	dB	dBuV	dB	
1	2480.200	101.21	-----	-----	94.31	6.90	Peak
2	2484.000	42.04	74.00	-31.96	35.13	6.91	Peak

Note:

1. Level = Read Level + Factor
2. Factor = Antenna Factor + Cable Loss - Preamp Factor
3. Over Limit = Level - Limit Line
4. The emission levels of other frequencies are very lower than the limit and not show in test report.

Right

Frequency (MHz)	Peak Measurement (dBμV/m)	Duty Cycle Factor (dB)	Average Measurement (dBμV/m)	Margin (dB)	Average Limit (dBμV/m)	Result
2480	101.92	-20.915	81.005	--	--	Pass
2483.8	43.63	-20.915	22.715	-31.285	54.000	Pass

Note:

1. Average Measurement=Peak Measurement + Duty Cycle Factor
2. The Duty Cycle is refer to section 5.

Site :HY-CB02
 Condition :3m ,HORIZONTAL
 mode :TX_2.4g Wireless_2402MHz
 Test by :Rock

Date: 2023-09-15

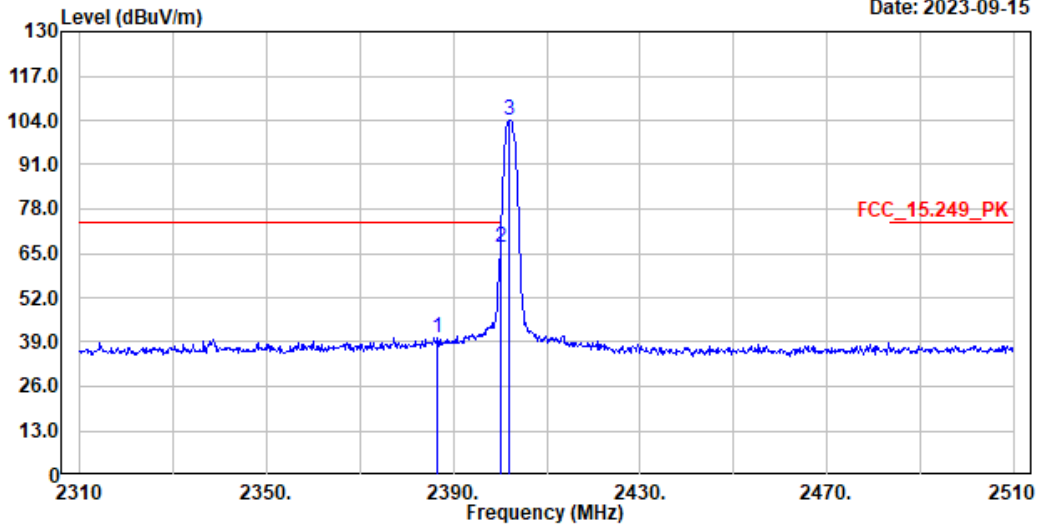

No.	Frequency	Level	Limit	Over	Read	Factor	Remark
	MHz	dBuV/m	dBuV/m	dB	dBuV	dB	
1	2386.400	40.12	74.00	-33.88	33.30	6.82	Peak
2	2400.000	66.82	74.00	-7.18	60.09	6.73	Peak
3	2402.000	103.94	-----	-----	97.21	6.73	Peak

Note:

1. Level = Read Level + Factor
2. Factor = Antenna Factor + Cable Loss - Preamp Factor
3. Over Limit = Level - Limit Line
4. The emission levels of other frequencies are very lower than the limit and not show in test report.

Left

Frequency (MHz)	Peak Measurement (dBμV/m)	Duty Cycle Factor (dB)	Average Measurement (dBμV/m)	Margin (dB)	Average Limit (dBμV/m)	Result
2338	42.76	-20.915	21.845	-32.155	54.000	Pass
2400	69.24	-20.915	48.325	-5.675	54.000	Pass
2402	103.88	-20.915	82.965	--	--	Pass

Note:

1. Average Measurement=Peak Measurement + Duty Cycle Factor
2. The Duty Cycle is refer to section 5.

Site :HY-CB02
 Condition :3m ,VERTICAL
 mode :TX_2.4g Wireless_2402MHz
 Test by :Rock

Date: 2023-09-15

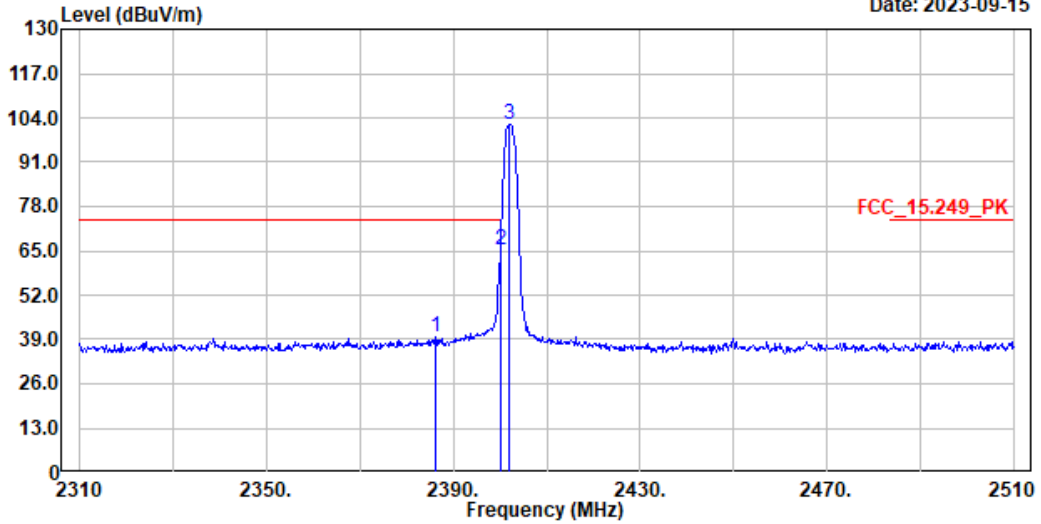

No.	Frequency	Level	Limit	Over	Read	Factor	Remark
	MHz	dBuV/m	dBuV/m	dB	dBuV	dB	
1	2386.200	39.50	74.00	-34.50	32.68	6.82	Peak
2	2400.000	65.33	74.00	-8.67	58.60	6.73	Peak
3	2402.000	102.28	-----	-----	95.55	6.73	Peak

Note:

1. Level = Read Level + Factor
2. Factor = Antenna Factor + Cable Loss - Preamp Factor
3. Over Limit = Level - Limit Line
4. The emission levels of other frequencies are very lower than the limit and not show in test report.

Left

Frequency (MHz)	Peak Measurement (dBμV/m)	Duty Cycle Factor (dB)	Average Measurement (dBμV/m)	Margin (dB)	Average Limit (dBμV/m)	Result
2385	42.78	-20.915	21.865	-32.135	54.000	Pass
2400	71.38	-20.915	50.465	-3.535	54.000	Pass
2402	106.35	-20.915	85.435	--	--	Pass

Note:

1. Average Measurement=Peak Measurement + Duty Cycle Factor
2. The Duty Cycle is refer to section 5.

Site :HY-CB02
 Condition :3m ,Horizontal
 mode :TX_2.4g Wireless_2480MHz
 Test by :Rock

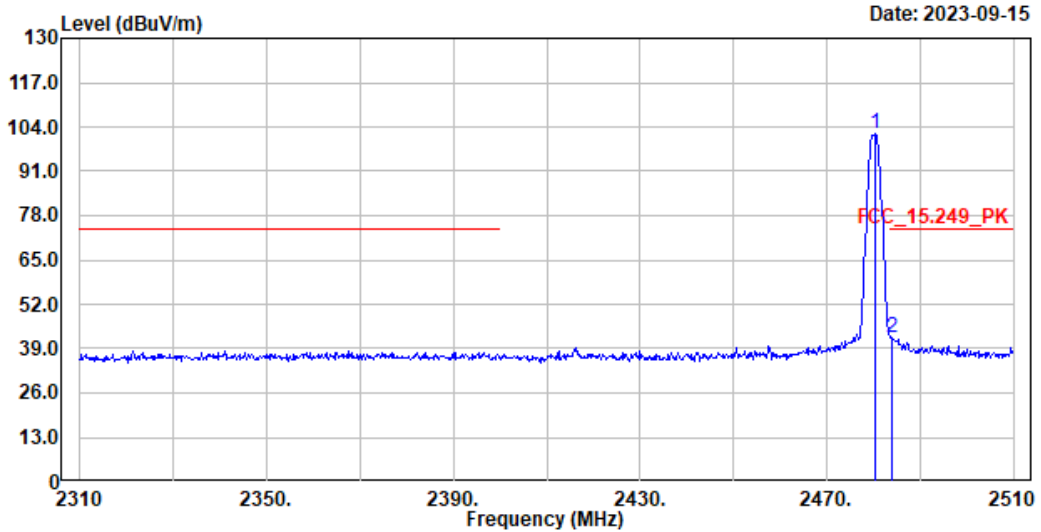

No.	Frequency	Level	Limit	Over	Read	Factor	Remark
	MHz	dBuV/m	dBuV/m	dB	dBuV	dB	
1	2480.200	101.80	-----	-----	94.90	6.90	Peak
2	2483.800	42.36	74.00	-31.64	35.45	6.91	Peak

Note:

1. Level = Read Level + Factor
2. Factor = Antenna Factor + Cable Loss - Preamp Factor
3. Over Limit = Level - Limit Line
4. The emission levels of other frequencies are very lower than the limit and not show in test report.

Left

Frequency (MHz)	Peak Measurement (dBμV/m)	Duty Cycle Factor (dB)	Average Measurement (dBμV/m)	Margin (dB)	Average Limit (dBμV/m)	Result
2480.2	102.45	-20.915	81.535	--	--	Pass
2483.8	44.48	-20.915	23.565	-30.435	54.000	Pass

Note:

1. Average Measurement=Peak Measurement + Duty Cycle Factor
2. The Duty Cycle is refer to section 5.

Site :HY-CB02
 Condition :3m ,VERTICAL
 mode :TX_2.4g Wireless_2480MHz
 Test by :Rock

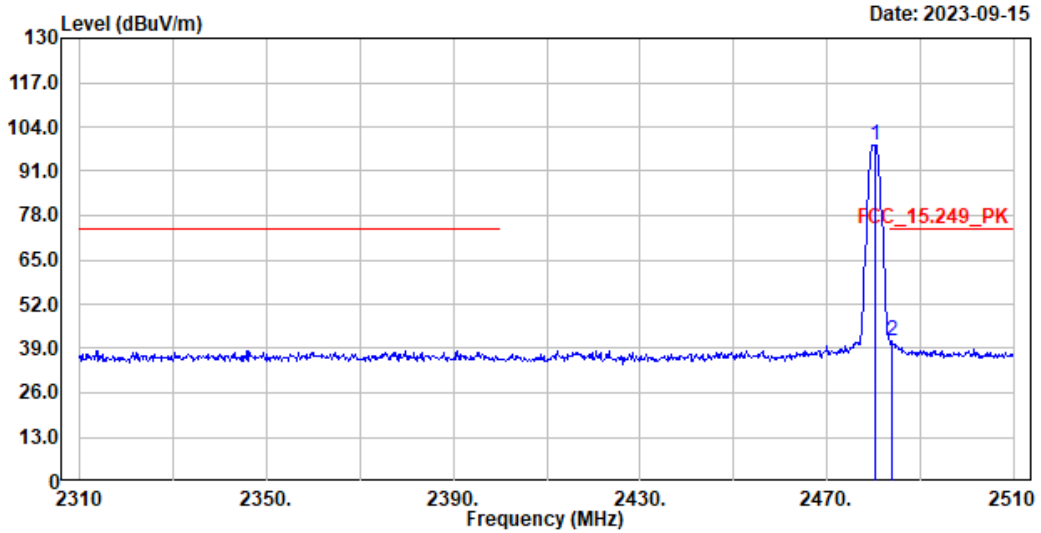

No.	Frequency	Level	Limit	Over	Read	Factor	Remark
	MHz	dBuV/m	dBuV/m	Limit	Level	dB	
1	2480.400	98.84	-----	-----	91.94	6.90	Peak
2	2483.800	41.33	74.00	-32.67	34.42	6.91	Peak

Note:

1. Level = Read Level + Factor
2. Factor = Antenna Factor + Cable Loss - Preamp Factor
3. Over Limit = Level - Limit Line
4. The emission levels of other frequencies are very lower than the limit and not show in test report.

Left

Frequency (MHz)	Peak Measurement (dBμV/m)	Duty Cycle Factor (dB)	Average Measurement (dBμV/m)	Margin (dB)	Average Limit (dBμV/m)	Result
2480.2	104.72	-20.915	83.805	--	--	Pass
2483.6	45.4	-20.915	24.485	-29.515	54.000	Pass

Note:

1. Average Measurement=Peak Measurement + Duty Cycle Factor
2. The Duty Cycle is refer to section 5.

5. Duty Cycle

5.1. Test Setup

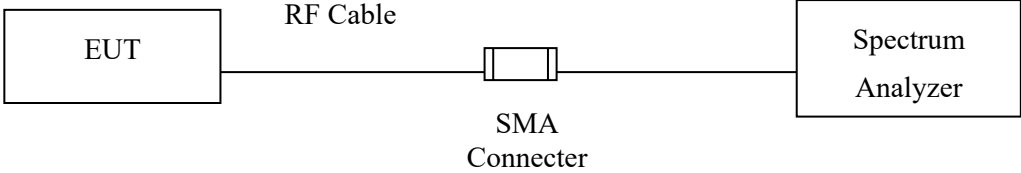

5.2. Test Result of Duty Cycle

Product : Wireless headphone
 Test Item : Duty Cycle Data
 Test Mode : Transmit_Right

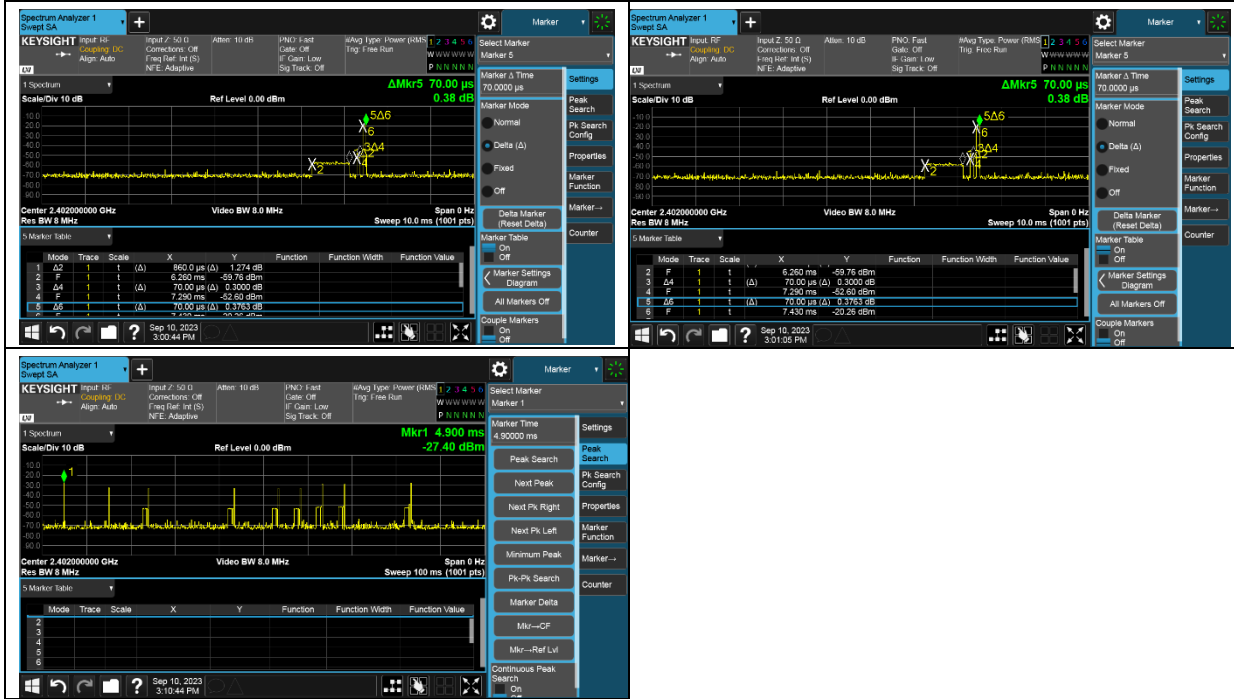

Time on of 100ms = 9.000ms
 Duty Cycle= 9ms / 100ms= 0.09
 Duty Cycle correction factor= 20 LOG 0.09= -20.915 dB

Duty Cycle correction factor	-20.915 dB
------------------------------	------------

Product : Wireless headphone
 Test Item : Duty Cycle Data
 Test Mode : Transmit_Left



Time on of 100ms = 9.000ms
 Duty Cycle= 9ms / 100ms= 0.09
 Duty Cycle correction factor= 20 LOG 0.09= -20.915 dB

Duty Cycle correction factor	-20.915 dB
------------------------------	------------