

Regulatory WLAN Antenna Information

(English Language Required for Regulatory Review / Approval)

(OEM/ODM or antenna vendor is required to complete this document with platform antenna information.

Remove references and make this your own document)

Platform information					
Brand	ODM	****End product model name	Intel platform (ex: Yes or No)	Platform Type (ex: regular NB, convertible PC, AIO...etc)	*SAR minimum separation (mm)
ASUS	NO	HN7306WI/WV/WU	NO	Convertible PC	3.8

*****Please fill in exact product model name and make sure the model name is visible on product cover or any parts for end users recognize for authority inspection.

Antenna information			
Vendor	Type(Main/Aux)	Antenna Part number (Main)	Antenna Part number (Aux)
PULSE	PIFA	TZ29250	TZ29250

Peak gain w/ cable loss (dBi)*										
	2.4GHz 2400- 2483.5MHz	5.2GHz 5150- 5250MHz	5.3GHz 5250- 5350MHz	5.6GHz 5470- 5725MHz	5.8GHz 5725- 5850MHz	5.9GHz 5850- 5895MHz	6.2GHz 5925- 6425MHz	6.5GHz 6425- 6525MHz	6.7GHz 6525- 6875MHz	7GHz 6875- 7125MHz
Main	-0.27	1.32	2.73	2.60	3.01	3.08	3.77	3.91	4.53	4.03
Aux	0.97	-0.12	-0.12	3.40	3.70	3.34	3.87	3.03	4.05	4.07

Reference Gain/Type/ Separation distance

Antenna Type	Antenna Peak gain (in dBi)											Distance to the end user(mm)
	2.4GHz 2400- 2483.5MHz	5.2GHz 5150-5250MHz	5.3GHz 5250-5350MHz	5.6GHz 5470-5725MHz	5.8GHz 5725-5850MHz	5.9GHz 5850-5895MHz	6.2GHz 5925- 6425MHz	6.5GHz 6425-6525MHz	6.7GHz 6525- 6875MHz	7GHz 6875- 7125MHz		
Design	3	5	5	5	5	5	5	5	5	5	Generic sku: refer to modular FCC SAR report Mid-power sku: ≥8 Low power sku: ≥5	
PIFA	3.18	4.92	4.92	4.92	4.92	4.92	4.76	4.29	4.6	4.61		4.09
Dipole	2.42	3.87	3.87	3.87	3.87	3.87	3.93	3.61	3.6	3.61		3.14

Notes (marked with *)

* SAR minimum separation (mm)

- Regular NB: Minimum antenna-to-body (from antenna bottom to the bottom of the device)

- Tablet / Convertible PC: Minimum antenna-to-edge (5 sides of the device)

- Mini-tablet: Minimum antenna-to-edge (6 sides of the device)

* 3D Peak Antenna gain should be equal or greater than -2 dBi

- If a host integrator plans to use a lower gain antenna of the same type, additional CBP(FCC)/EDT(EU) testing need to be performed while the module is installed in the host.

1. Applicable test methods

<insert test description here for test method>

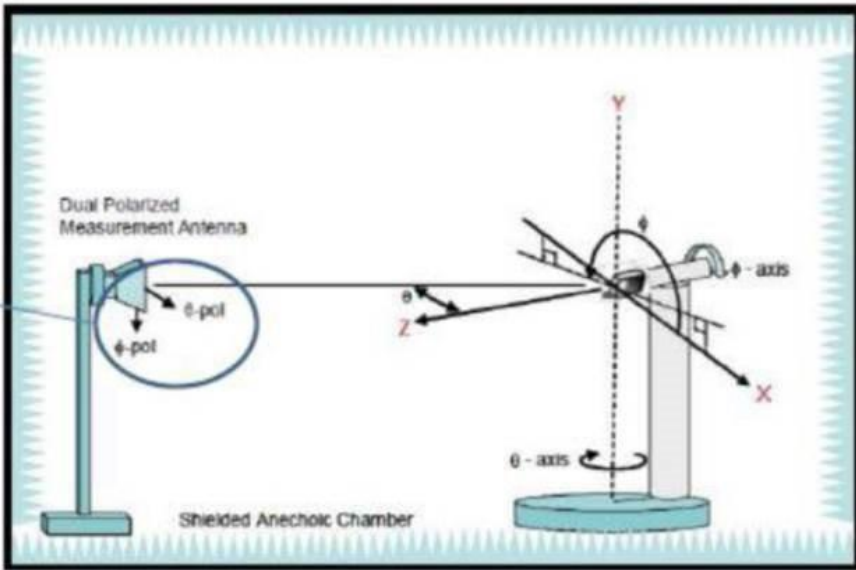

2. Test & System Description

a. Test setup

<insert test diagram here for test site utilized>

ETS 8500

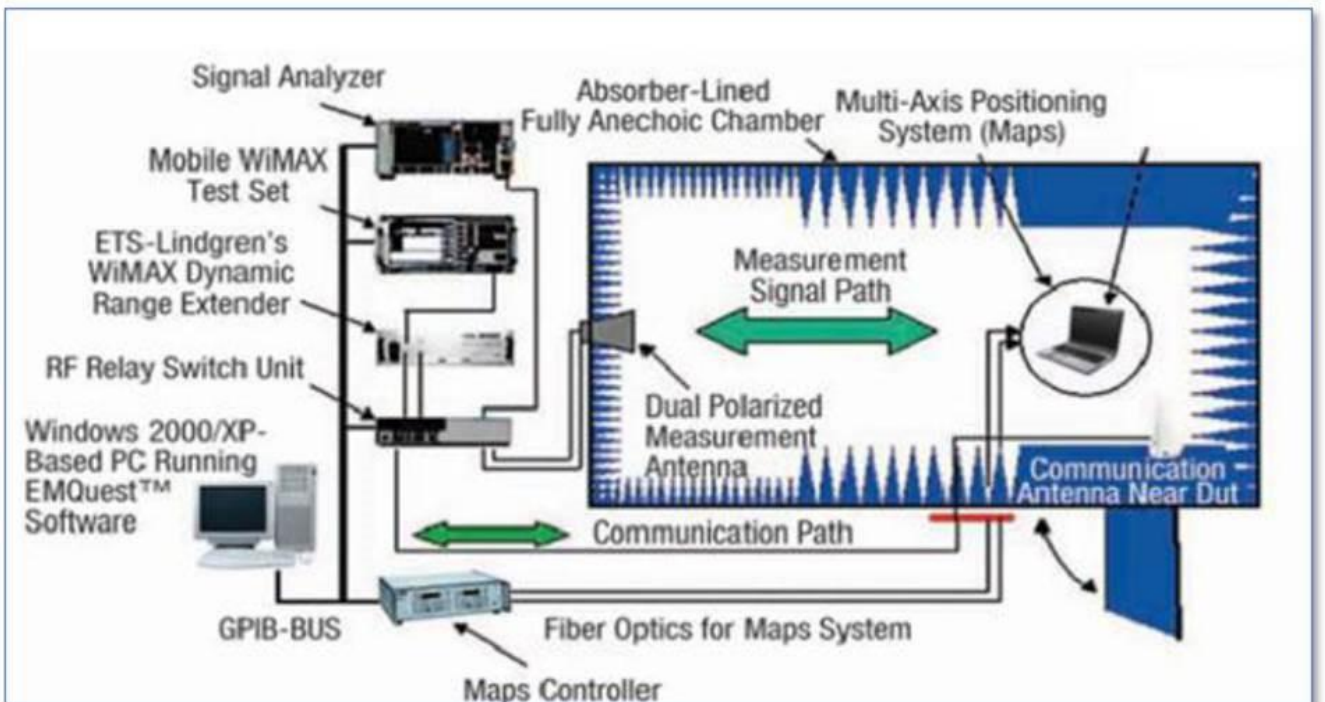

b. Equipment list

<insert test diagram here for test site utilized>

Device	Type/Model	Serial#	Manufacturer	Cal. Date	Cal. Due Date
Anechoic Chamber	AMS-8500	1191	ETS-Lindgren	2022/3/9	2024/3/9
Turn Table	2090	-	ETS-Lindgren	N/A	N/A
Switch & Positioning systems	7001-002	116599	ETS-Lindgren	N/A	N/A
Measurement SW	EMQuest v1.0.8	1352	ETS-Lindgren	N/A	N/A
Boresight antenna mast	2090	-	ETS-Lindgren	N/A	N/A
Spectrum Analyzer	N9010A	X16-96096	Agilent Technologies	2021/7/25	2023/7/25
Horn antenna	3164-06	00143257	ETS-Lindgren	2022/4/3	2024/4/3
Horn antenna + Amplifier + HPF6.4	115195	00117614	ETS-Lindgren	2021/8/18	2023/8/18
Cable 2.5m - 30MHz to 18GHz	0500990992500KE	19.23.395	Radial	2022/1/10	2024/1/10
Cable 1.2m - 18 to 40GHz	UFA147A-0-0480-200200	MFR 64639223720-003	Micro-coax	2022/1/10	2024/1/10
Cable 1m - 1GHz to 18GHz	UFA147A	-	Utiliflex	2022/1/10	2024/1/10
Cable 2m - 26.5MHz to 40GHz	794-9191-200A	E00327	Atem	2022/1/10	2024/1/10
Cable 1m - 30MHz to 18GHz	UFB311A-0-0590-50U50U	MFR 64639223230-001	Micro-coax	2022/1/10	2024/1/10
Cable 7m - DC-18GHz	0501051057000GX	19.35.850	Radial	2022/1/10	2024/1/10
Cable 7m - 18GHz to 40GHz	R286304009	-	Radial	2022/1/10	2024/1/10
Cable 1.5m - DC-18GHz	CBL-1.5M-SMSM+	202879	Mini-Circuits	2022/1/10	2024/1/10
Temp & Humidity Logger	GM-108A	-		2021/5/2	2023/5/2

D

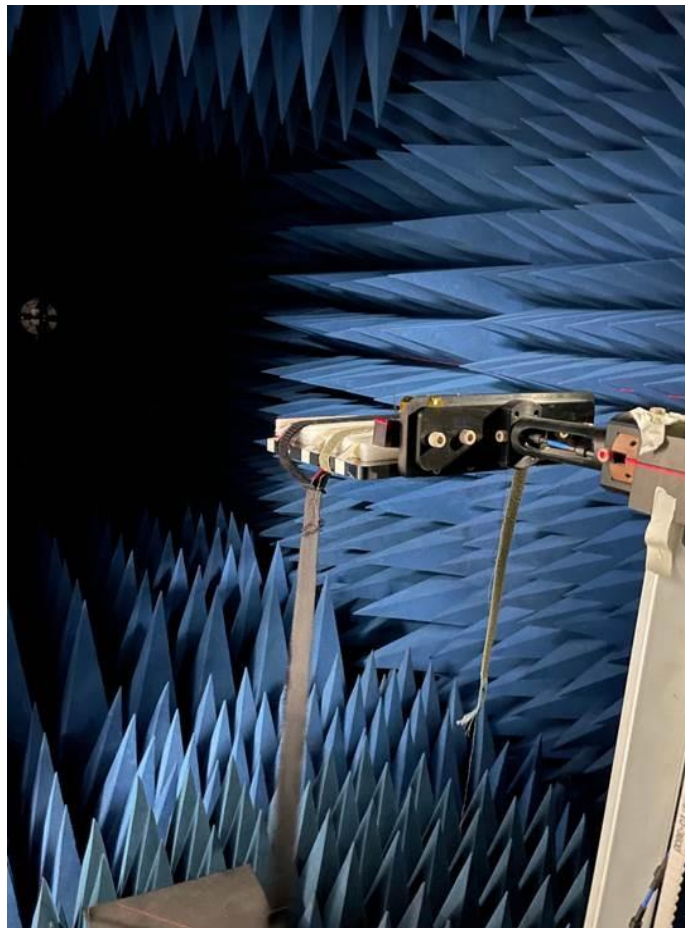

Antenna Sample / Antenna Data

Requirements for worldwide regulatory approval

Section	Description of Required OEM / ODM Antenna Information	US / IC	EU	Japan	Taiwan	S Korea
1A	Part Number for Antenna only	Required	Required	Required	Required	Required
1B	Antenna Manufacturer Name	Required	Required	Required	Required	Required
1C	Description of Antenna Type	Required	N/A	N/A	N/A	N/A
1D	Part number of Antenna Assembly / cable impedance, length & diameter.	Required	Desired	Desired	Desired	Desired
1E	1E Main, Aux & Tx3 antenna (Peak Gain W/ cable loss) *	Required	Required	Required	Required	Required
	1E OR 1F, 1G, 1H					
1F	Main, Aux & Tx3 antenna (Peak Gain only) *	Required	Required	Required	Required	Required
1G	VSWR of cable including connector	Required	Required	Required	Required	Required
1H	Main, Aux & Tx3 antenna(Cable loss W/ connector) *	Required	Required	Required	Required	Required
2	Dimensioned Photographs and Drawings of Main, Aux, and Tx3 (or Rx3) antennas	Required	Required	Required	Required	Required
3	Radiation patterns of antennas loaded in the host platform.	Required	Desired	Required	Required	Required
4	Platform model name / number - correlated to antenna manufacturer and antenna part number	Required	Required	Desired	Required	Desired
5	Photograph(s) or Drawings showing location of antennas in platform. <u>(S. Korea requires photographs of antennas for approval submission). Taiwan requires pictures of each antenna type shown in the system.</u>	Required	Required	Desired	Required (Photos)	Required (Photos)
6	Mech. drawings / photos with dimensions of antenna locations and distance from end-user (For evaluation of SAR testing requirement).	Required	N/A	N/A	N/A	N/A
7	Photograph(s) or Drawings showing the location of all antennas (WLAN, other) and distance between those transmitting antennas. Information will be used to evaluate whether co-location testing is required.	Required	N/A	N/A	N/A	N/A
8	Local representative contact information for LMA/ PARS process.	Required	N/A	N/A	N/A	N/A

Antenna Information

Section 1. Antenna Assembly Specifications

Clamshell mode

1A Antenna Part Number	1B Manu- facture	1C Antenna Type	1D Cable Assembly Part Number and Information	Freq Range MHz	1E *Peak Gain W/ Cable loss (dBi)	1F Peak Gain w/o Cable Loss (dBi)	1G VSWR	1H Cable Loss (dB)
TZ29250 Main/Rx1 Antenna	PULSE	PIFA	50 ohm Coaxial Length: 251.9 mm Diamter: 0.81 mm Low Loss Connector: IPEX 20565-001R-13	2400-2483.5	-0.27 dBi, (peak)	0.43 dBi, (peak)	2 dB, (peak)	0.7 dB, (peak)
				5150-5250	1.32 dBi, (peak)	2.36 dBi, (peak)	2 dB, (peak)	1.04 dB, (peak)
				5250-5350	2.73 dBi, (peak)	3.77 dBi, (peak)	2 dB, (peak)	1.04 dB, (peak)
				5470-5725	2.60 dBi, (peak)	3.67 dBi, (peak)	2 dB, (peak)	1.07 dB, (peak)
				5725-5850	3.01 dBi, (peak)	4.10 dBi, (peak)	2 dB, (peak)	1.09 dB, (peak)
				5850-5895	3.08 dBi, (peak)	4.21 dBi, (peak)	2 dB, (peak)	1.13 dB, (peak)
				5925-6425	3.77 dBi, (peak)	4.94 dBi, (peak)	2 dB, (peak)	1.17 dB, (peak)
				6425-6525	3.91 dBi, (peak)	5.08 dBi, (peak)	2 dB, (peak)	1.17 dB, (peak)
				6525-6875	4.53 dBi, (peak)	5.72 dBi, (peak)	2 dB, (peak)	1.19 dB, (peak)
				6875-7125	4.03 dBi, (peak)	5.22 dBi, (peak)	2 dB, (peak)	1.19 dB, (peak)
1A Antenna Part Number	1B Manufacture	1C Antenna Type	1D Cable Assembly Part Number and Information	Freq Range MHz	1E *Peak Gain W/ Cable loss (dBi)	1F Peak Gain w/o Cable Loss (dBi)	1G VSWR	1H Cable Loss (dB)
TZ29250 Aux/Rx2 Antenna	PULSE	PIFA	50 ohm Coaxial Length: 299.9 mm Diamter: 0.81 mm Low Loss Connector: IPEX 20565-001R-13	2400-2483.5	0.97 dBi, (peak)	1.78 dBi, (peak)	2 dB, (peak)	0.81 dB, (peak)
				5150-5250	-0.12 dBi, (peak)	1.08 dBi, (peak)	2 dB, (peak)	1.2 dB, (peak)
				5250-5350	-0.12 dBi, (peak)	1.09 dBi, (peak)	2 dB, (peak)	1.21 dB, (peak)
				5470-5725	3.40 dBi, (peak)	4.65 dBi, (peak)	2 dB, (peak)	1.25 dB, (peak)
				5725-5850	3.70 dBi, (peak)	4.96 dBi, (peak)	2 dB, (peak)	1.26 dB, (peak)
				5850-5895	3.34 dBi, (peak)	4.60 dBi, (peak)	2 dB, (peak)	1.26 dB, (peak)
				5925-6425	3.87 dBi, (peak)	5.18 dBi, (peak)	2 dB, (peak)	1.31 dB, (peak)
				6425-6525	3.03 dBi, (peak)	4.38 dBi, (peak)	2 dB, (peak)	1.35 dB, (peak)
				6525-6875	4.05 dBi, (peak)	5.43 dBi, (peak)	2 dB, (peak)	1.38 dB, (peak)
				6875-7125	4.07 dBi, (peak)	5.50 dBi, (peak)	2 dB, (peak)	1.43 dB, (peak)

• 3D Antenna Peak Gain required being test in system basis

Tablet Mode

1A Antenna Part Number	1B Manu- facture	1C Antenna Type	1D Cable Assembly Part Number and Information	Freq Range MHz	1E *Peak Gain W/ Cable loss (dBi)	1F Peak Gain w/o Cable Loss (dBi)	1G VSWR	1H Cable Loss (dB)
TZ29250 Main/Rx1 Antenna	PULSE	PIFA	50 ohm Coaxial Length: 251.9 mm Diamter: 0.81 mm Low Loss Connector: IPEX 20565-001R-13	2400-2483.5	1.22 dBi, (peak)	1.92 dBi, (peak)	2 dB, (peak)	0.7 dB, (peak)
				5150-5250	2.52 dBi, (peak)	3.56 dBi, (peak)	2 dB, (peak)	1.04 dB, (peak)
				5250-5350	1.48 dBi, (peak)	2.52 dBi, (peak)	2 dB, (peak)	1.04 dB, (peak)
				5470-5725	3.41 dBi, (peak)	4.48 dBi, (peak)	2 dB, (peak)	1.07 dB, (peak)
				5725-5850	4.69 dBi, (peak)	5.78 dBi, (peak)	2 dB, (peak)	1.09 dB, (peak)
				5850-5895	4.29 dBi, (peak)	5.42 dBi, (peak)	2 dB, (peak)	1.13 dB, (peak)
				5925-6425	3.95 dBi, (peak)	5.12 dBi, (peak)	2 dB, (peak)	1.17 dB, (peak)
				6425-6525	4.26 dBi, (peak)	5.43 dBi, (peak)	2 dB, (peak)	1.17 dB, (peak)
				6525-6875	4.15 dBi, (peak)	5.34 dBi, (peak)	2 dB, (peak)	1.19 dB, (peak)
			6875-7125	3.55 dBi, (peak)	4.74 dBi, (peak)	2 dB, (peak)	1.19 dB, (peak)	
1A Antenna Part Number	1B Manufacture	1C Antenna Type	1D Cable Assembly Part Number and Information	Freq Range MHz	1E *Peak Gain W/ Cable loss (dBi)	1F Peak Gain w/o Cable Loss (dBi)	1G VSWR	1H Cable Loss (dB)
TZ29250 Aux/Rx2 Antenna	PULSE	PIFA	50 ohm Coaxial Length: 299.9 mm Diamter: 0.81 mm Low Loss Connector: IPEX 20565-001R-13	2400-2483.5	1.63 dBi, (peak)	2.44 dBi, (peak)	2 dB, (peak)	0.81 dB, (peak)
				5150-5250	1.30 dBi, (peak)	2.50 dBi, (peak)	2 dB, (peak)	1.2 dB, (peak)
				5250-5350	1.99 dBi, (peak)	3.20 dBi, (peak)	2 dB, (peak)	1.21 dB, (peak)
				5470-5725	3.29 dBi, (peak)	4.54 dBi, (peak)	2 dB, (peak)	1.25 dB, (peak)
				5725-5850	4.36 dBi, (peak)	5.62 dBi, (peak)	2 dB, (peak)	1.26 dB, (peak)
				5850-5895	3.39 dBi, (peak)	4.65 dBi, (peak)	2 dB, (peak)	1.26 dB, (peak)
				5925-6425	3.64 dBi, (peak)	4.95 dBi, (peak)	2 dB, (peak)	1.31 dB, (peak)
				6425-6525	1.45 dBi, (peak)	2.80 dBi, (peak)	2 dB, (peak)	1.35 dB, (peak)
				6525-6875	3.44 dBi, (peak)	4.82 dBi, (peak)	2 dB, (peak)	1.38 dB, (peak)
			6875-7125	3.61 dBi, (peak)	5.04 dBi, (peak)	2 dB, (peak)	1.43 dB, (peak)	

• 3D Antenna Peak Gain required being test in system basis

Section 3. Radiation characteristics of antennae Loaded in Host Platform

Clamshell mode

Main antenna

Max Antenna 3D Radiation Pattern 2400-2483.5 MHz

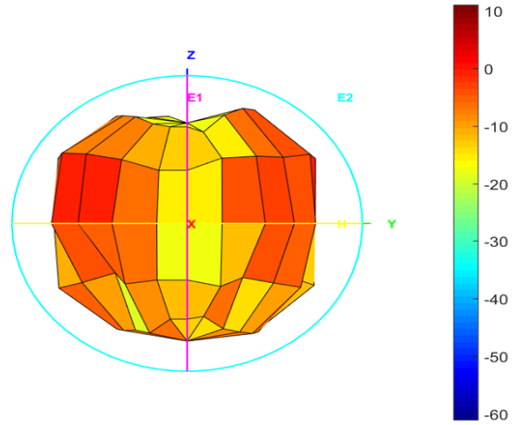

Frequency (MHz)	Peak Gain w/ Cable Loss (dBi)
2400-2483.5	2.60

Max Antenna 3D Radiation Pattern 5150-5250 MHz

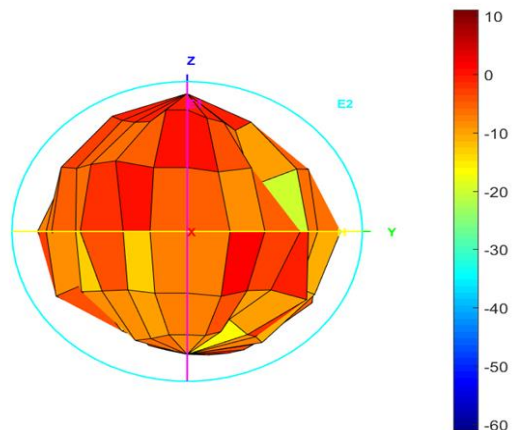

Frequency (MHz)	Peak Gain w/ Cable Loss (dBi)
5150-5250	3.08

Max Antenna 3D Radiation Pattern 5250-5350 MHz

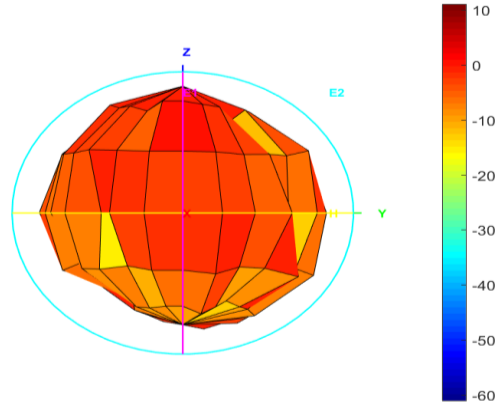

Frequency (MHz)	Peak Gain w/ Cable Loss (dBi)
5250-5350	3.77

Max Antenna 3D Radiation Pattern 5470-5725 MHz

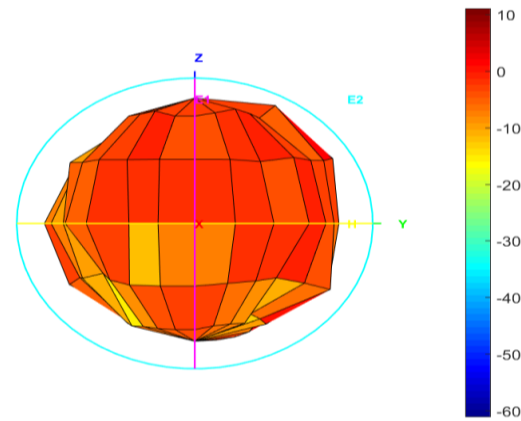

Frequency (MHz)	Peak Gain w/ Cable Loss (dBi)
5470-5725	3.91

Max Antenna 3D Radiation Pattern 5725-5850 MHz

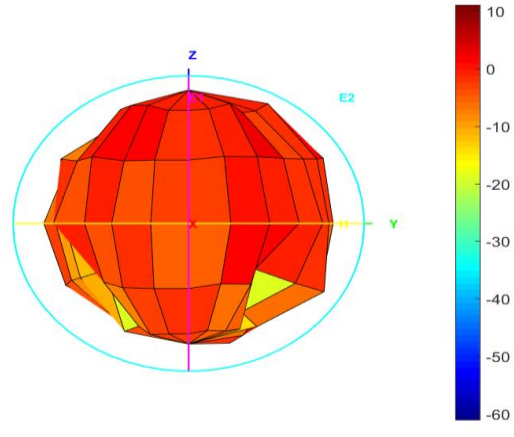

Frequency (MHz)	Peak Gain w/ Cable Loss (dBi)
5725-5850	3.01

Max Antenna 3D Radiation Pattern 5850-5895 MHz

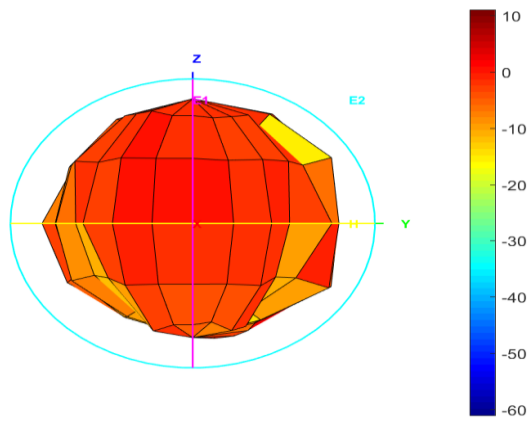

Frequency (MHz)	Peak Gain w/ Cable Loss (dBi)
5850-5895	3.08

Max Antenna 3D Radiation Pattern 5925-6425 MHz

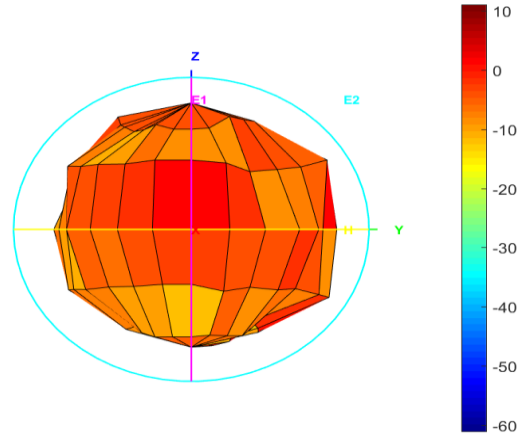

Frequency (MHz)	Peak Gain w/ Cable Loss (dBi)
5925-6425	3.77

Max Antenna 3D Radiation Pattern 6425-6525 MHz

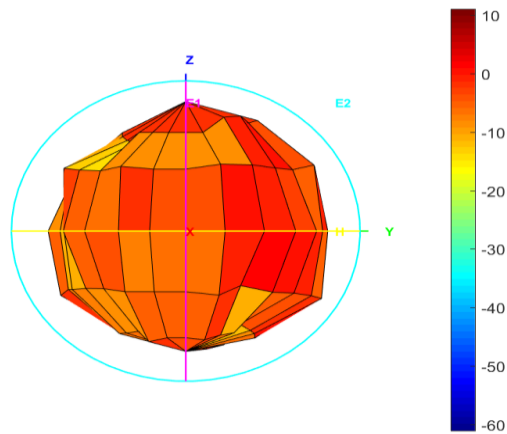

Frequency (MHz)	Peak Gain w/ Cable Loss (dBi)
6425-6525	3.91

Max Antenna 3D Radiation Pattern 6525-6875 MHz

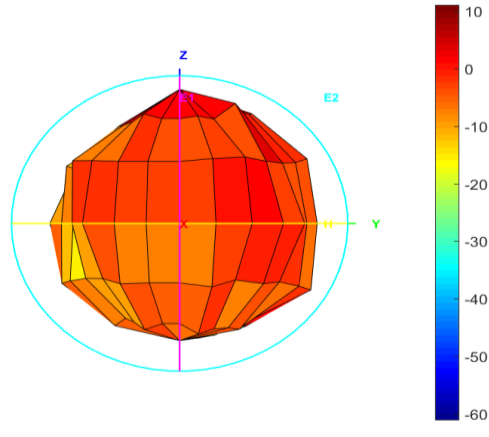

Frequency (MHz)	Peak Gain w/ Cable Loss (dBi)
6525-6875	4.53

Max Antenna 3D Radiation Pattern 6875-7125 MHz

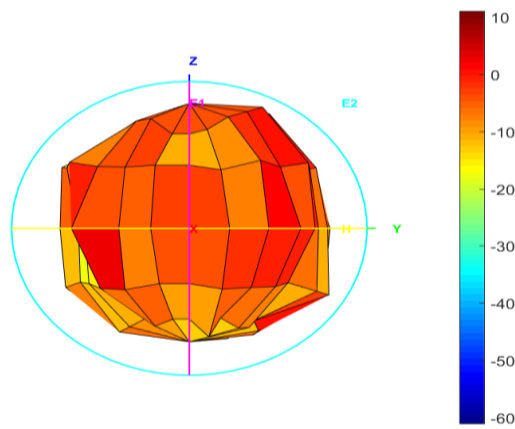

Frequency (MHz)	Peak Gain w/ Cable Loss (dBi)
6875-7125	4.03

Auxiliary Antenna

Max Antenna 3D Radiation Pattern 2400-2483.5 MHz

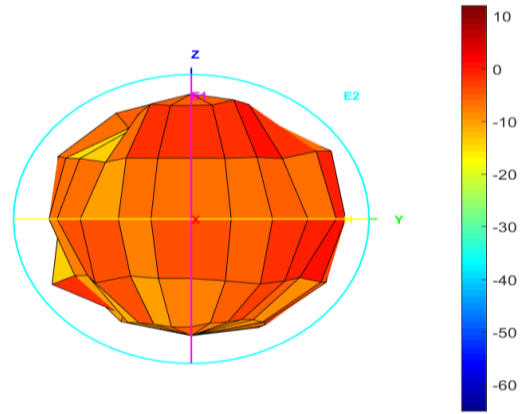

Frequency (MHz)	Peak Gain w/ Cable Loss (dBi)
2400-2483.5	0.00

Max Antenna 3D Radiation Pattern 5150-5250 MHz

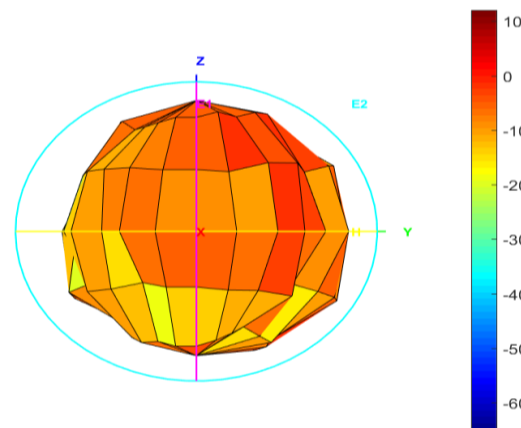

Frequency (MHz)	Peak Gain w/ Cable Loss (dBi)
5150-5250	0.00

Max Antenna 3D Radiation Pattern 5250-5350 MHz

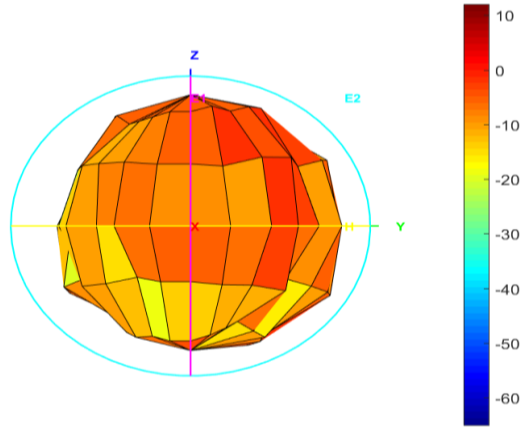

Frequency (MHz)	Peak Gain w/ Cable Loss (dBi)
5250-5350	0.00

Max Antenna 3D Radiation Pattern 5470-5725 MHz

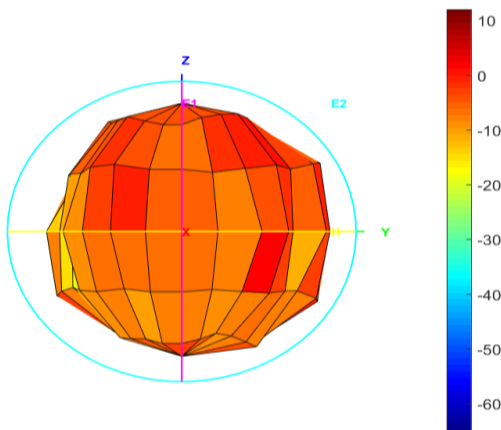

Frequency (MHz)	Peak Gain w/ Cable Loss (dBi)
5470-5725	0.00

Max Antenna 3D Radiation Pattern 5725-5850 MHz

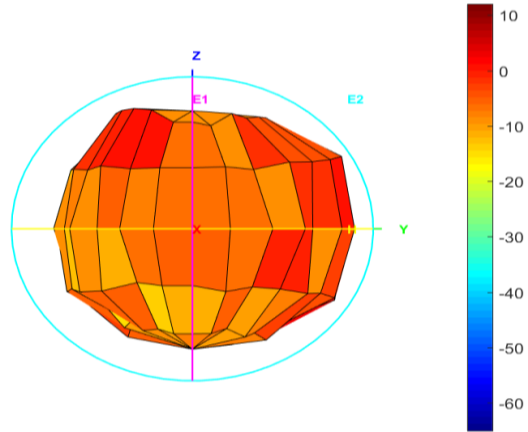

Frequency (MHz)	Peak Gain w/ Cable Loss (dBi)
5725-5850	0.00

Max Antenna 3D Radiation Pattern 5850-5895 MHz

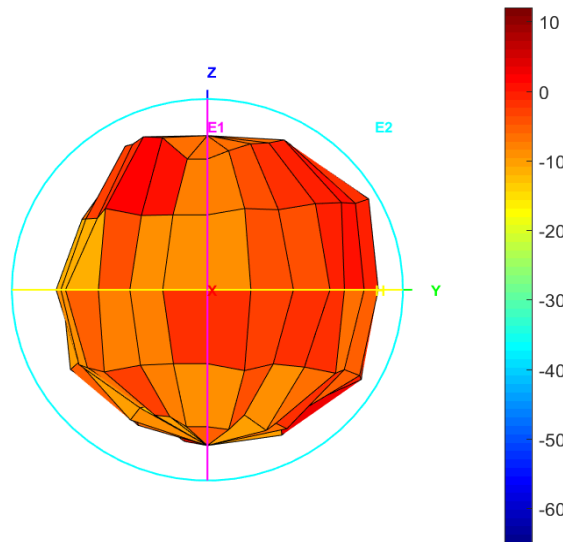

Frequency (MHz)	Peak Gain w/ Cable Loss (dBi)
5850-5895	3.34

Max Antenna 3D Radiation Pattern 5925-6425 MHz

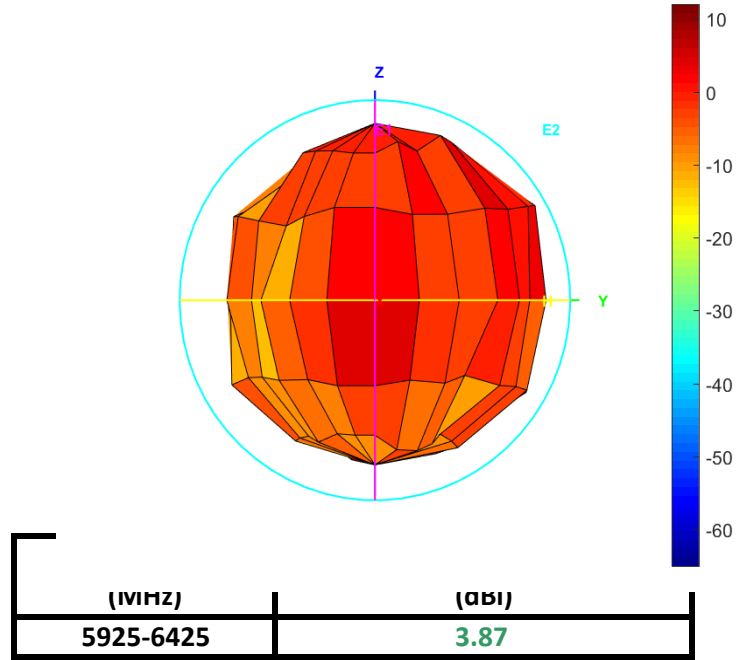

Max Antenna 3D Radiation Pattern 6425-6525 MHz

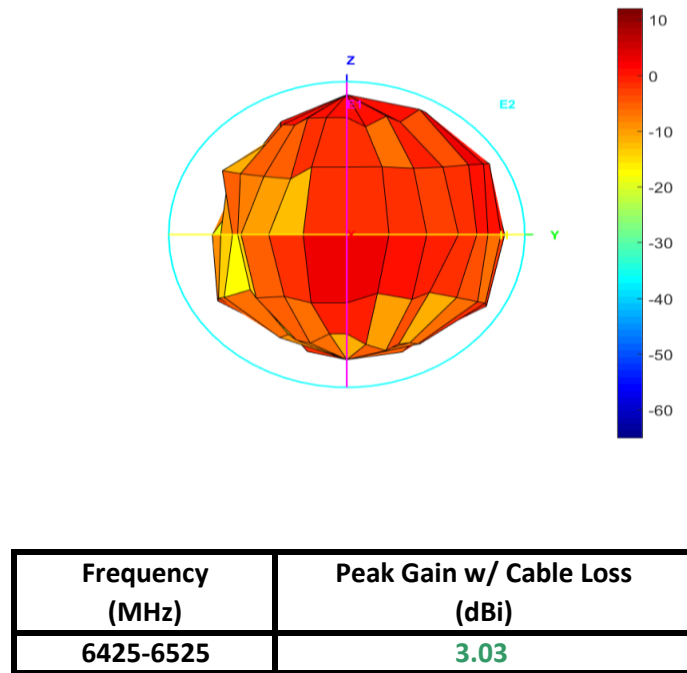

Max Antenna 3D Radiation Pattern 6525-6875 MHz

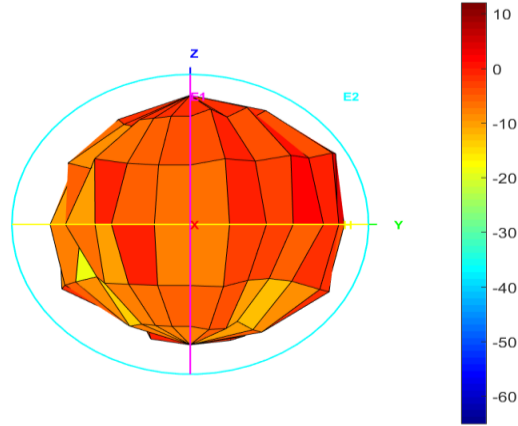

Frequency (MHz)	Peak Gain w/ Cable Loss (dBi)
6525-6875	4.05

Max Antenna 3D Radiation Pattern 6875-7125 MHz

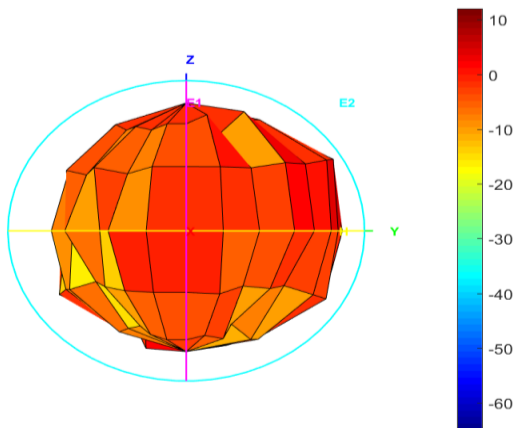

Frequency (MHz)	Peak Gain w/ Cable Loss (dBi)
6875-7125	4.07

Tablet mode

Main antenna

Max Antenna 3D Radiation Pattern 2400-2483.5 MHz

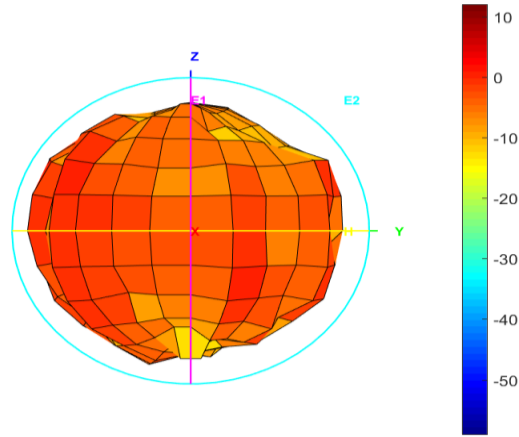

Frequency (MHz)	Peak Gain w/ Cable Loss (dBi)
2400-2483.5	1.22

Max Antenna 3D Radiation Pattern 5150-5250 MHz

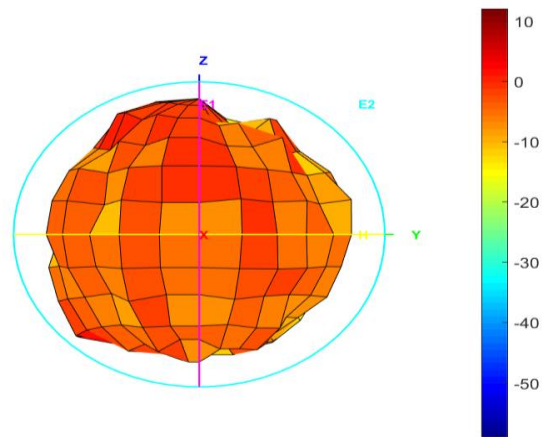

Frequency (MHz)	Peak Gain w/ Cable Loss (dBi)
5150-5250	2.52

Max Antenna 3D Radiation Pattern 5250-5350 MHz

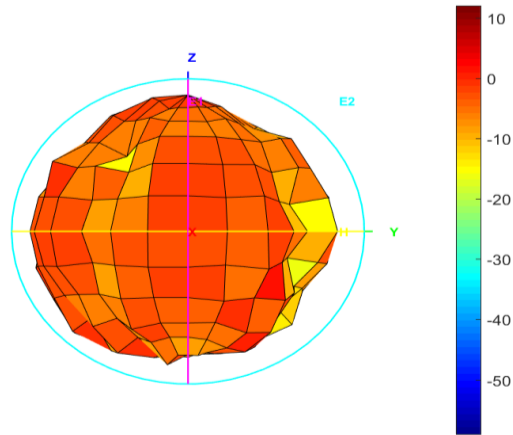

Frequency (MHz)	Peak Gain w/ Cable Loss (dBi)
5250-5350	1.48

Max Antenna 3D Radiation Pattern 5470-5725 MHz

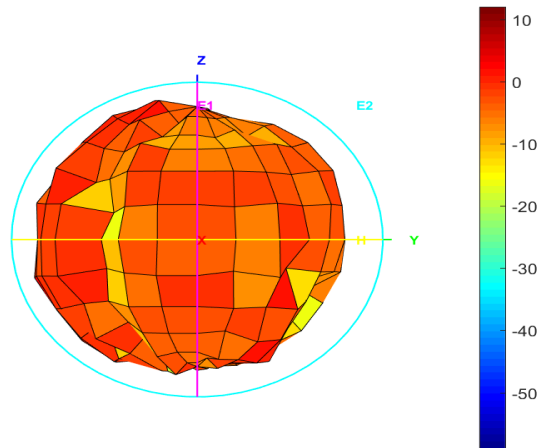

Frequency (MHz)	Peak Gain w/ Cable Loss (dBi)
5470-5725	3.41

Max Antenna 3D Radiation Pattern 5725-5850 MHz

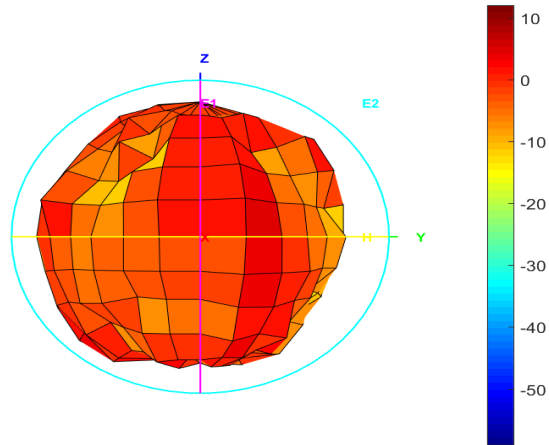

Frequency (MHz)	Peak Gain w/ Cable Loss (dBi)
5725-5850	4.69

Max Antenna 3D Radiation Pattern 5850-5895 MHz

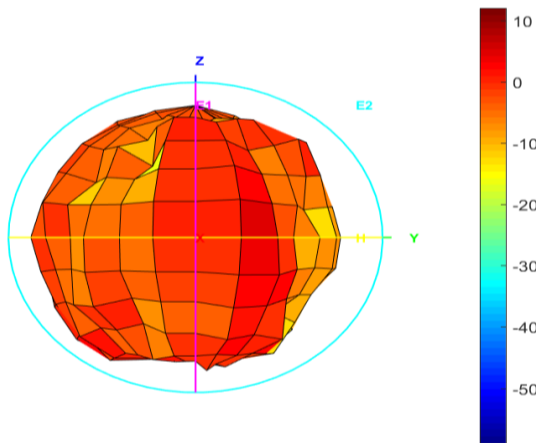

Frequency (MHz)	Peak Gain w/ Cable Loss (dBi)
5850-5895	4.29

Max Antenna 3D Radiation Pattern 5925-6425 MHz

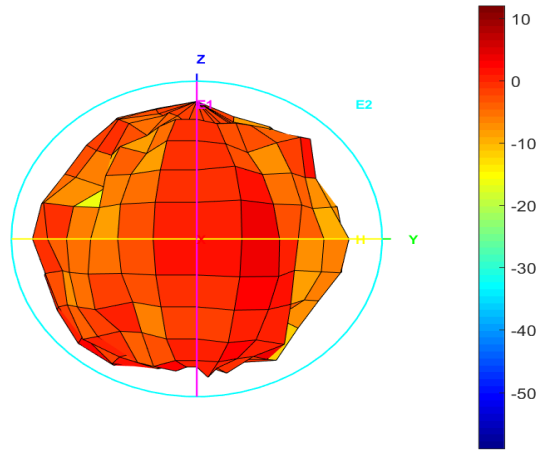

Frequency (MHz)	Peak Gain w/ Cable Loss (dBi)
5925-6425	3.95

Max Antenna 3D Radiation Pattern 6425-6525 MHz

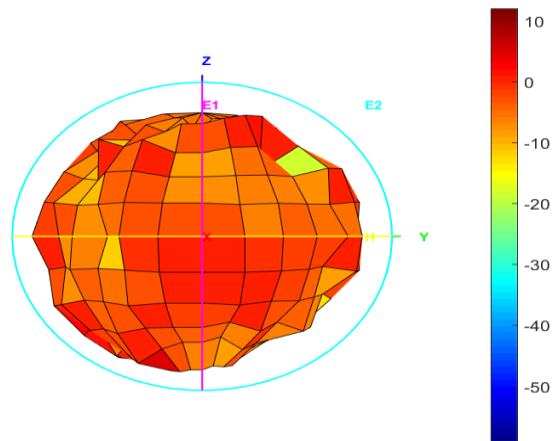

Frequency (MHz)	Peak Gain w/ Cable Loss (dBi)
6425-6525	4.26

Max Antenna 3D Radiation Pattern 6525-6875 MHz

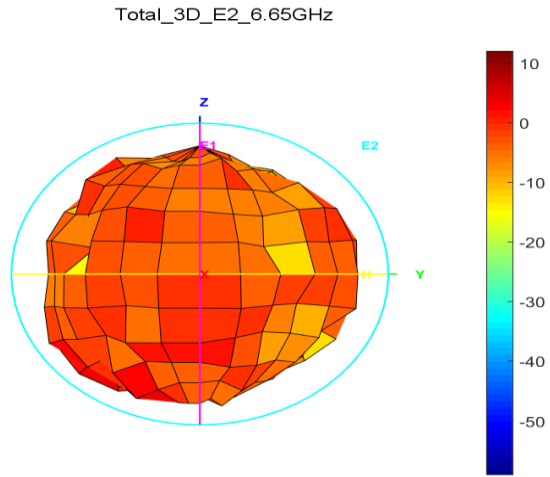

Frequency (MHz)	Peak Gain w/ Cable Loss (dBi)
6525-6875	4.15

Max Antenna 3D Radiation Pattern 6875-7125 MHz

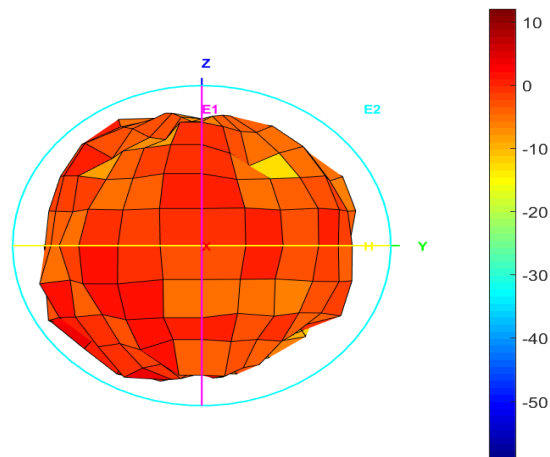

Frequency (MHz)	Peak Gain w/ Cable Loss (dBi)
6875-7125	3.55

Auxiliary Antenna

Max Antenna 3D Radiation Pattern 2400-2483.5 MHz

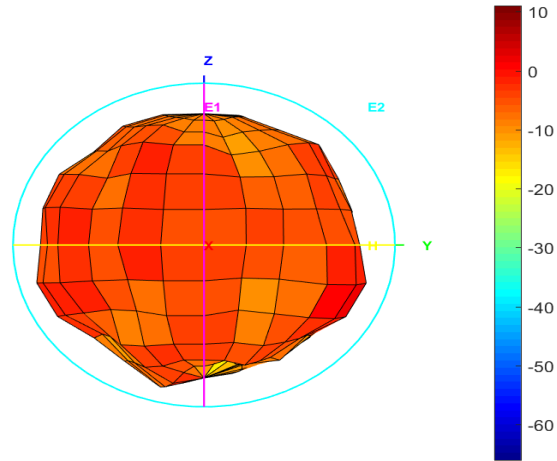

Frequency (MHz)	Peak Gain w/ Cable Loss (dBi)
2400-2483.5	1.63

Max Antenna 3D Radiation Pattern 5150-5250 MHz

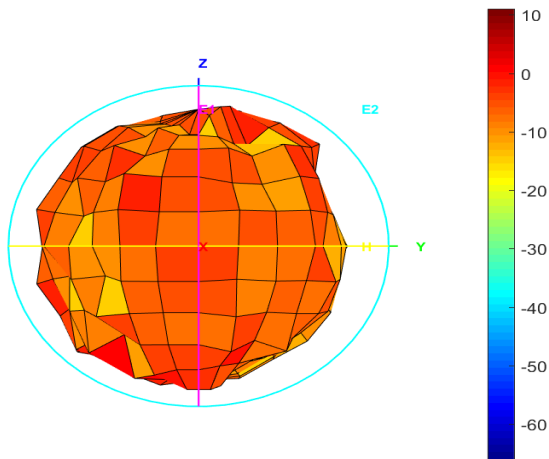

Frequency (MHz)	Peak Gain w/ Cable Loss (dBi)
5150-5250	1.30

Max Antenna 3D Radiation Pattern 5250-5350 MHz

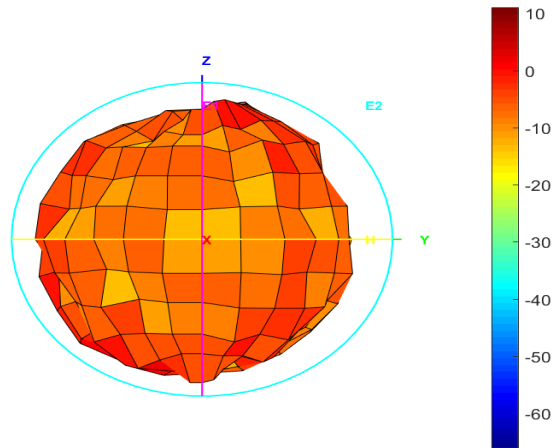

Frequency (MHz)	Peak Gain w/ Cable Loss (dBi)
5250-5350	1.99

Max Antenna 3D Radiation Pattern 5470-5725 MHz

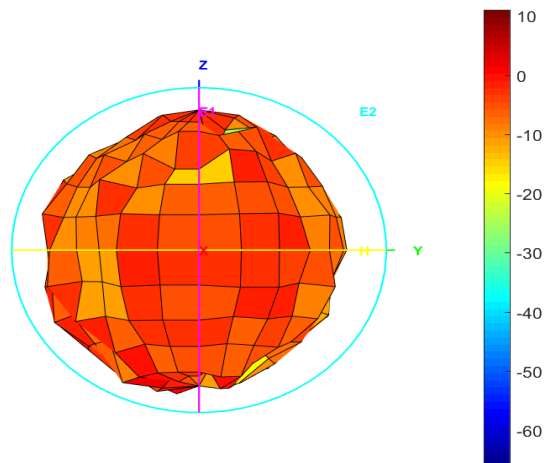

Frequency (MHz)	Peak Gain w/ Cable Loss (dBi)
5470-5725	3.29

Max Antenna 3D Radiation Pattern 5725-5850 MHz

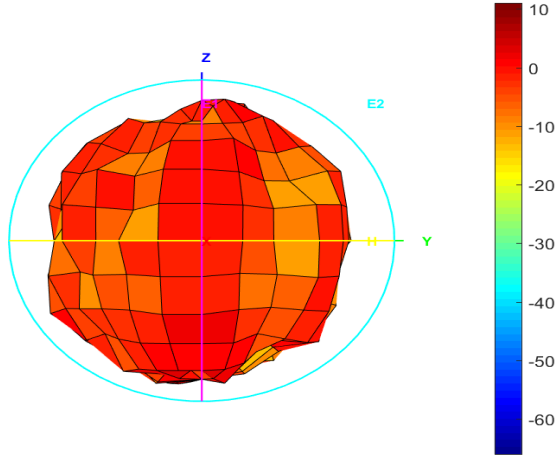

Frequency (MHz)	Peak Gain w/ Cable Loss (dBi)
5725-5850	4.36

Max Antenna 3D Radiation Pattern 5850-5895 MHz

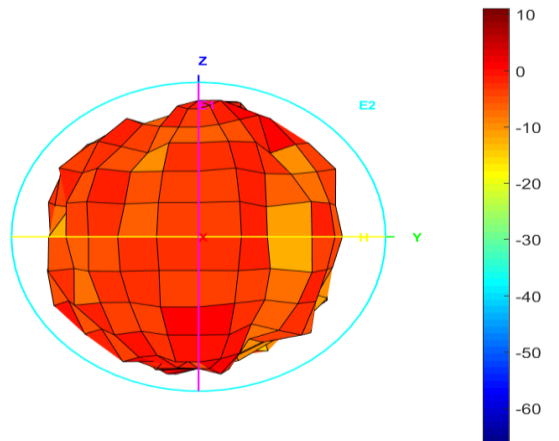

Frequency (MHz)	Peak Gain w/ Cable Loss (dBi)
5850-5895	3.39

Max Antenna 3D Radiation Pattern 5925-6425 MHz

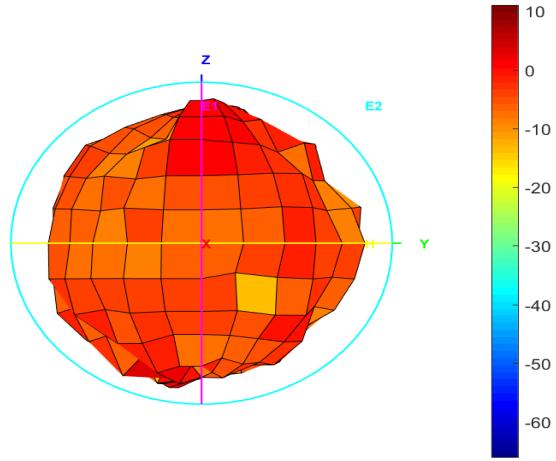

Frequency (MHz)	Peak Gain w/ Cable Loss (dBi)
5925-6425	3.64

Max Antenna 3D Radiation Pattern 6425-6525 MHz

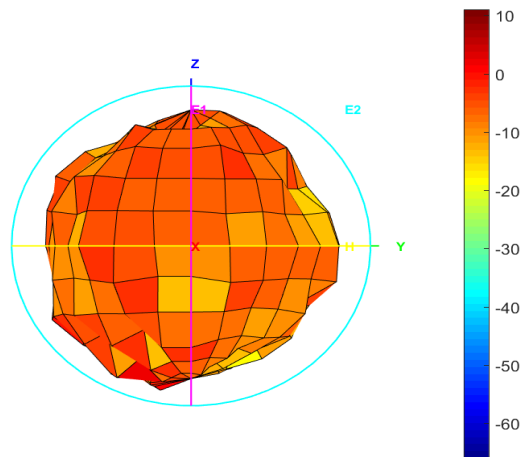

Frequency (MHz)	Peak Gain w/ Cable Loss (dBi)
6425-6525	1.45

Max Antenna 3D Radiation Pattern 6525-6875 MHz

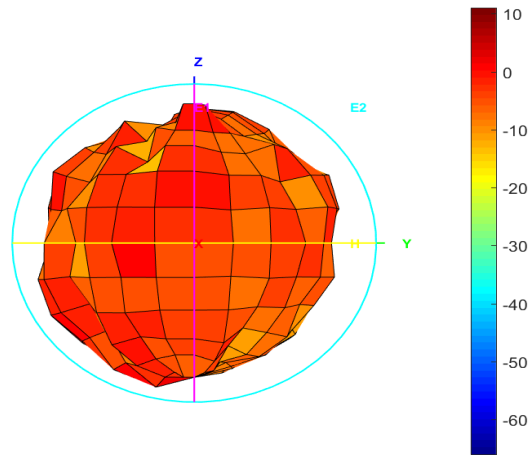

Frequency (MHz)	Peak Gain w/ Cable Loss (dBi)
6525-6875	3.44

Max Antenna 3D Radiation Pattern 6875-7125 MHz

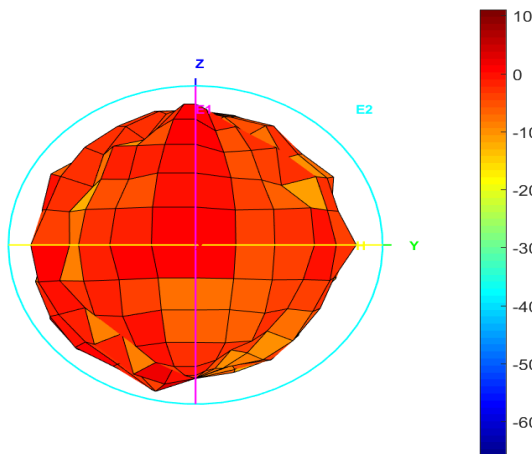

Frequency (MHz)	Peak Gain w/ Cable Loss (dBi)
6875-7125	3.61