

RF Test Report

Applicant : ASUSTeK COMPUTER INC.
Product Type : Wireless Keyboard and Mouse Set CW100
Trade Name : ASUS
Model Number : CW100
Applicable Standard : FCC 47 CFR PART 15 SUBPART C
ANSI C63.10:2009
Received Date : Jul. 08, 2021
Test Period : Jul. 12 ~ Jul. 30, 2021
Issued Date : Aug. 19, 2021

Issued by

A Test Lab Techno Corp.
No. 140-1, Changan Street, Bade District,
Taoyuan City 33465, Taiwan (R.O.C.)
Tel : +886-3-2710188 / Fax : +886-3-2710190



Taiwan Accreditation Foundation accreditation number: 1330

Frequency Range : 9 kHz to 40 GHz

Test Firm MRA designation number: TW0010

Note:

- 1.The test results are valid only for samples provided by customers and under the test conditions described in this report.
- 2.This report shall not be reproduced except in full, without the written approval of A Test Lab Technology Corporation.
- 3.The relevant information is provided by customers in this test report. According to the correctness, appropriateness or completeness of the information provided by the customer, if there is any doubt or error in the information which affects the validity of the test results, the laboratory does not take the responsibility.



Revision History

Rev.	Issued Date	Revisions	Revised By
00	Aug. 05, 2021	Initial Issue	Snow Wang
01	Aug. 19, 2021	Update chapter 2 (P.6)	Snow Wang

Verification of Compliance

Applicant : ASUSTeK COMPUTER INC.
Product Type : Wireless Keyboard and Mouse Set CW100
Trade Name : ASUS
Model Number : CW100
FCC ID : MSQ-KB-CW100
EUT Rated Voltage : DC 1.5 V, 10 mA
Test Voltage : DC 1.5 V
Applicable Standard : FCC 47 CFR PART 15 SUBPART C
ANSI C63.10:2009
Test Result : Complied

Performing Lab. : A Test Lab Techno Corp.
No. 140-1, Changan Street, Bade District,
Taoyuan City 33465, Taiwan (R.O.C.)
Tel : +886-3-2710188 / Fax : +886-3-2710190
Taiwan Accreditation Foundation accreditation number: 1330
<http://www.atl-lab.com.tw/e-index.htm>



A Test Lab Techno Corp. tested the above equipment in accordance with the requirements set forth in the above standards. All indications of Pass/Fail in this report are opinions expressed by A Test Lab Techno Corp. based on interpretations and/or observations of test results. The test results show that the equipment tested is capable of demonstrating compliance with the requirements as documented in this report.

Approved By : Ken Yang
(Manager) (Ken Yang)



TABLE OF CONTENTS

1	General Information	5
1.1.	Summary of Test Result	5
1.2.	Measurement Uncertainty	5
2	EUT Description	6
3	Test Methodology	7
3.1.	Mode of Operation	7
3.2.	EUT Test Step	7
3.3.	Configuration of Test System Details	7
3.4.	Test Instruments	8
3.5.	Test Site Environment	8
4	Measurement Procedure	9
4.1.	Radiated Emission Measurement	9
4.2.	Band Edges Measurement	13
4.3.	20 dB Bandwidth Measurement	14
4.4.	Antenna Measurement	15
5	Test Results	16
	Annex A. Conducted Test Results	16
	Annex B. Radiated Emission Measurement	18



1 General Information

1.1. Summary of Test Result

Standard	Item	Result	Remark
15.207	AC Power Conducted Emission	N/A	This device use DC power source.
15.249(a)	Transmitter Radiated Emissions	PASS	----
15.249(d)	Band Edge Measurement	PASS	----
15.215(c)	20 dB RF Bandwidth	PASS	----
---	Occupied Bandwidth Measurement	Reference	----
15.203	Antenna Requirement	PASS	----

Standard	Description
CFR47, Part 15, Subpart C	Intentional Radiators
ANSI C63. 10: 2013	American National Standard of Procedures for Compliance Testing of Unlicensed Wireless Devices

Decision Rule

- Uncertainty is not included.
- Uncertainty is included.

1.2. Measurement Uncertainty

Test Item	Frequency Range	Uncertainty (dB)
Conducted Emission	150 kHz ~ 30 MHz	2.68
Radiated Emission	9 kHz ~ 30 MHz	2.14
	30 MHz ~ 1000 MHz	4.99
	1000 MHz ~ 18000 MHz	4.99
	18000 MHz ~ 26500 MHz	4.23
	26500 MHz ~ 40000 MHz	4.39
RF Bandwidth	4.79 %	



2 EUT Description

Applicant	ASUSTeK COMPUTER INC. 1F., No. 15, Lide Rd., Beitou Dist., Taipei City 112, Taiwan			
Manufacturer	ASUSTeK COMPUTER INC. 1F., No. 15, Lide Rd., Beitou Dist., Taipei City 112, Taiwan			
Product	Wireless Keyboard and Mouse Set CW100			
Trade Name	ASUS			
Model Number	CW100			
FCC ID	MSQ-KB-CW100			
Frequency Range	2404 - 2478 MHz			
Modulation Type	GFSK			
Number of Channel	38 CH			
Antenna Information	Manufacturer	Model Number	Type	Max. Gain (dBi)
	Dongguan Xinshenchuang Electronic Technology Co Ltd	DK-1101RH	PCB Antenna	0.9
	DongGuan Qiaohe Electronics CO.,LTD	DK-1101RH	PCB Antenna	0.9
	Note: The only difference is the manufacturer.			
Field Strength	80.74 dBuV/m			
Operate Temp. Range	+5 ~ +40 °C			

Channel list							
CH	MHz	CH	MHz	CH	MHz	CH	MHz
1	2404	11	2424	21	2444	31	2464
2	2406	12	2426	22	2446	32	2466
3	2408	13	2428	23	2448	33	2468
4	2410	14	2430	24	2450	34	2470
5	2412	15	2432	25	2452	35	2472
6	2414	16	2434	26	2454	36	2474
7	2416	17	2436	27	2456	37	2476
8	2418	18	2438	28	2458	38	2478
9	2420	19	2440	29	2460	---	---
10	2422	20	2442	30	2462	---	---

3 Test Methodology

3.1. Mode of Operation

Decision of Test ATL has verified the construction and function in typical operation. All the test modes were carried out with the EUT in normal operation, which was shown in this test report and defined as:

Pre-Test Mode
Mode 1: Transmit Mode
Mode 2: Continuous TX Mode

Final-Test Mode
Mode 2: Continuous TX Mode

Note: This product has two types: 104 Key and 105 Key. The 104 Key is the worst case.

3.2. EUT Test Step

1	Setup the EUT shown on "Configuration of Test System Details".
2	Turn on the power of EUT.

Measurement Software			
No.	Description	Software	Version
2	Radiated Emission	EZ EMC	1.1.4.4

3.3. Configuration of Test System Details

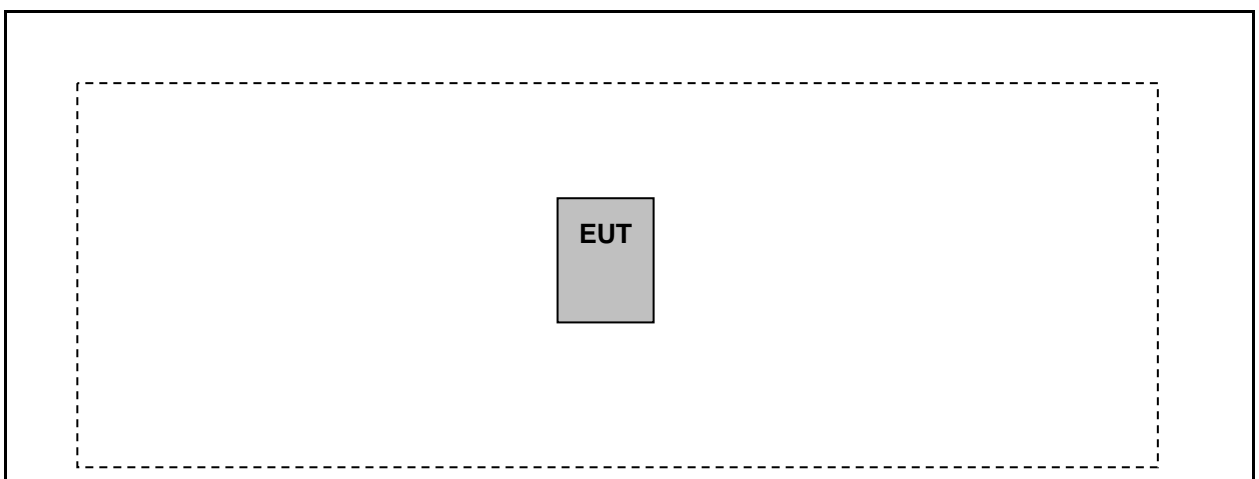



3.4. Test Instruments

For Radiated Emissions

Test Period: Jul. 12 ~ Jul. 18, 2021

Testing Engineer: Pink Li, Ida Chuang

Equipment	Manufacturer	Model Number	Serial Number	Cal. Date	Cal. Period
Spectrum Analyzer (2 Hz~50 GHz)	Keysight	N9030B	MY57143537	04/19/2021	1 year
Pre Amplifier (100 kHz~1.3 GHz)	Agilent	8447D	2944A11119	01/15/2021	1 year
Pre Amplifier (1~26.5 GHz)	Titan	T0912E01263025A 1F	002	07/23/2020	1 year
Broadband Antenna	Schwarzbeck	VULB9168	416	11/11/2020	1 year
Horn Antenna (1~18 GHz)	SCHWARZBECK MESS-ELEKTRONIK	BBHA9120D	9120D-550	08/17/2020	1 year
Horn Antenna (18~40 GHz)	ETS	3116	00086467	12/03/2020	1 year
Coaxial Cable	Titan	T0710AT327A10A 100	J11005	08/13/2020	1 year
Coaxial Cable	Titan	T0710AT327A10A 900	J11004	08/13/2020	1 year
Coaxial Cable	Titan	T0712AT340A12A 900	J11002	08/13/2020	1 year

For Conducted

Test Period: Jul. 29 ~ Jul. 30, 2021

Testing Engineer: Louis Shen

Equipment	Manufacturer	Model Number	Serial Number	Cal. Date	Cal. Period
Spectrum Analyzer	Keysight	N9010B	MY59071418	03/17/2021	1 year

Note: N.C.R. = No Calibration Request.

3.5. Test Site Environment

Items	Required (IEC 60068-1)	Actual
Temperature (°C)	15-35	20-30
Humidity (%RH)	25-75	45-75



4 Measurement Procedure

4.1. Radiated Emission Measurement

■ Limit

Frequency (MHz)	Field Strength ($\mu\text{V/m}$ at meter)	Measurement Distance (meter)
0.009 – 0.490	2400 / F (kHz)	300
0.490 – 1.705	24000 / F (kHz)	30
1.705 – 30.0	30	30
30 - 88	100	3
88-216	150	3
216-960	200	3
Above 960	500	3

Harmonic emissions limits comply with below 54 dBuV/m at 3 m. Other emissions radiated outside of the specified frequency bands, except for harmonics, shall be attenuated by at least 50 dB below the level of the fundamental or comply with the radiated emissions limits specified in section 15.209(a) limit in the table below has to be followed.

- Note: (1) The tighter limit applies at the band edges.
(2) Emission level (dBuV/m)=20 log Emission level ($\mu\text{V/m}$).

Limits of Radiated Emission Measurement (FCC 15.209)

Frequency (MHz)	Class A (dBuV/m) (at 3 m)		Class B (dBuV/m) (at 3 m)	
	Peak	AVG	Peak	AVG
0.009 – 0.490	80	60	74	54

- Notes: (1) The limit for radiated test was performed according to FCC PART 15C.
(2) The tighter limit applies at the band edges.
(3) Emission level (dBuV/m)=20 log Emission level ($\mu\text{V/m}$).

Limits of Radiated Emission Measurement (FCC Part 15.249)

Frequency Range (MHz)	Limit
2400-2483.5	Field strength of fundamental 50000 $\mu\text{V/m}$ (94 dB $\mu\text{V/m}$) @ 3 m
Above 2483.5	Field strength of harmonics 500 $\mu\text{V/m}$ (54 dB $\mu\text{V/m}$) @ 3 m

■ Setup

Below 1 GHz

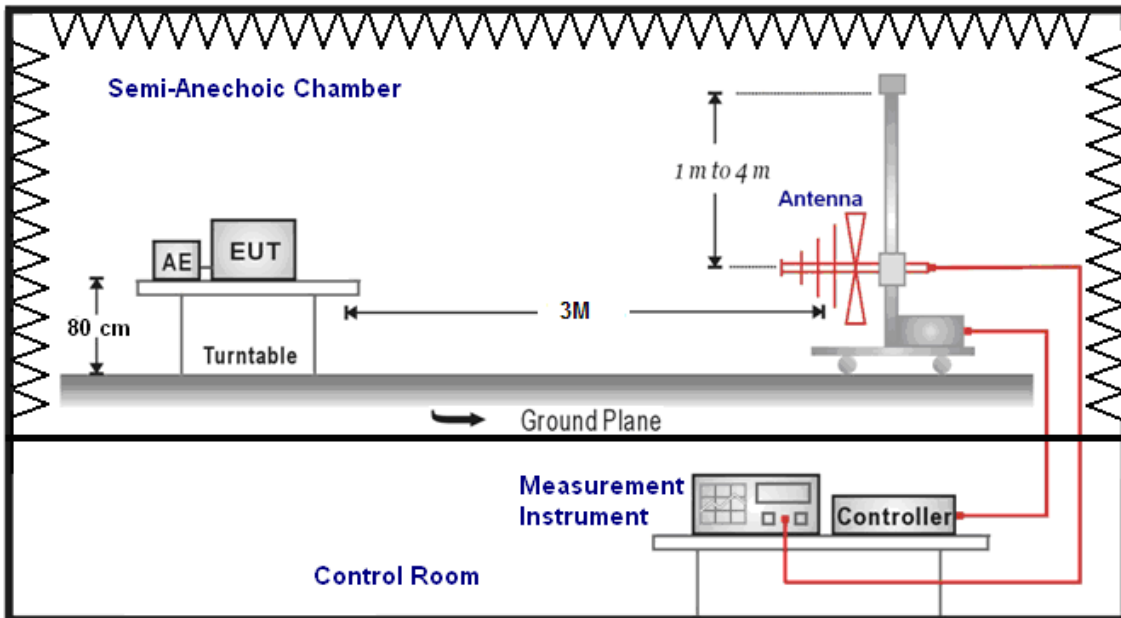

Above 1 GHz

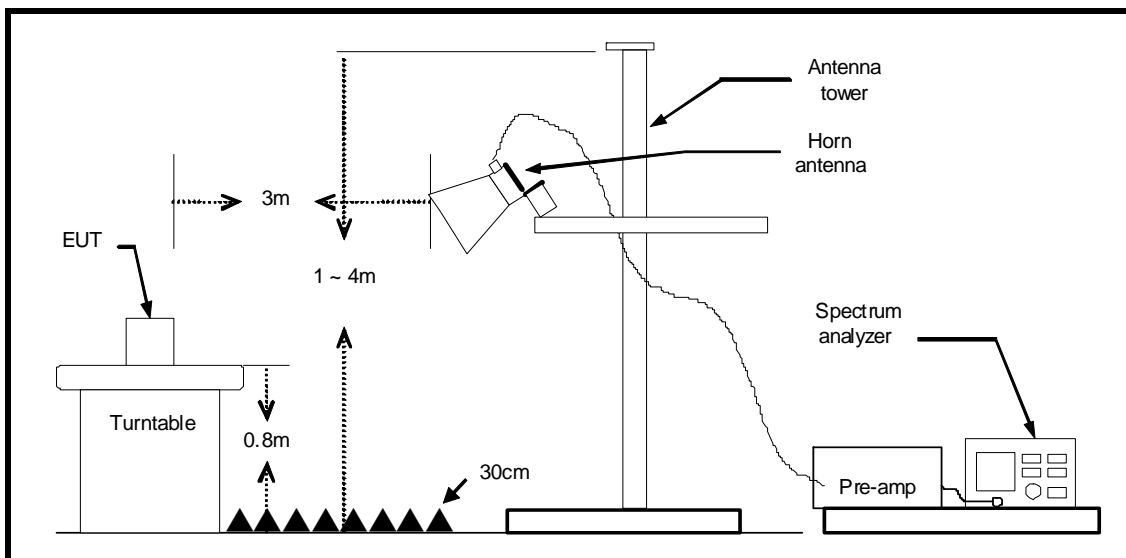



■ Test Procedure

Final radiation measurements were made on a three-meter, Semi Anechoic Chamber. The EUT system was placed on a nonconductive turntable which is 0.8 meters height, top surface 1.0 x 1.5 meter. The spectrum was examined from 250 MHz to 2.5 GHz in order to cover the whole spectrum below 10th harmonic which could generate from the EUT. During the test, EUT was set to transmit continuously & Measurements spectrum range from 30 MHz to 26.5 GHz is investigated.

For measurements below 1 GHz the resolution bandwidth is set to 100 kHz for peak detection measurements or 120 kHz for quasi-peak detection measurements. Peak detection is used unless otherwise noted as quasi-peak.

For measurements above 1 GHz the resolution bandwidth is set to 1 MHz, and then the video bandwidth is set to 3 MHz for peak measurements and 10 Hz for average measurements.

A nonconductive material surrounded the EUT to supporting the EUT for standing on three orthogonal planes. At each condition, the EUT was rotated 360 degrees, and the antenna was raised and lowered from one to four meters to find the maximum emission levels. Measurements were taken using both horizontal and vertical antenna polarization.

SCHWARZBECK MESS-ELEKTRONIK Biconilog Antenna (model VULB9163) at 3 Meter and the SCHWARZBECK Double Ridged Guide Antenna (model BBHA9120D&9170) was used in frequencies 1 – 26.5 GHz at a distance of 1 meter. All test results were extrapolated to equivalent signal at 3 meters utilizing an inverse linear distance extrapolation Factor (20 dB/decade).

For testing above 1 GHz, the emission level of the EUT in peak mode was 20 dB lower than average limit (that means the emission level in peak mode also complies with the limit in average mode), then testing will be stopped and peak values of EUT will be reported, otherwise, the emissions will be measured in average mode again and reported.

Appropriate preamplifiers were used for improving sensitivity and precautions were taken to avoid overloading or desensitizing the spectrum analyzer. No post – detector video filters were used in the test.

The spectrum analyzer's 6 dB bandwidth was set to 1 MHz, and the analyzer was operated in the peak detection mode, for frequencies both below and up 1 GHz. The average levels were obtained by subtracting the duty cycle correction factor from the peak readings.

The following procedures were used to convert the emission levels measured in decibels referenced to 1 microvolt (dBuV) into field intensity in micro volts pre meter (uV/m).

The actual field intensity in decibels referenced to 1 microvolt in to field intensity in micro volts per meter (dBuV/m).



The actual field intensity in referenced to 1 microvolt per meter (dBuV/m) is determined by algebraically adding the measured reading in dBuV, the antenna factor (dB), and cable loss (dB) and Subtracting the gain of preamplifier (dB) is auto calculate in spectrum analyzer.

$$(1) \text{ Amplitude (dBuV/m) = FI (dBuV) +AF (dBuV) +CL (dBuV)-Gain (dB)}$$

FI= Reading of the field intensity.

AF= Antenna factor.

CL= Cable loss.

P.S Amplitude is auto calculate in spectrum analyzer.

$$(2) \text{ Actual Amplitude (dBuV/m) = Amplitude (dBuV)-Dis(dB)}$$

The FCC specified emission limits were calculated according the EUT operating frequency and by following linear interpolation equations:

(a) For fundamental frequency : Transmitter Output < +30 dBm

(b) For spurious frequency : Spurious emission limits = fundamental emission limit /10

4.2. Band Edges Measurement

■ Limit

In any 100 kHz bandwidth outside the frequency band, the radio frequency power is at least 50 dB below that in the 100 kHz bandwidth within the band that contains the highest level of the desired power.

■ Test Setup

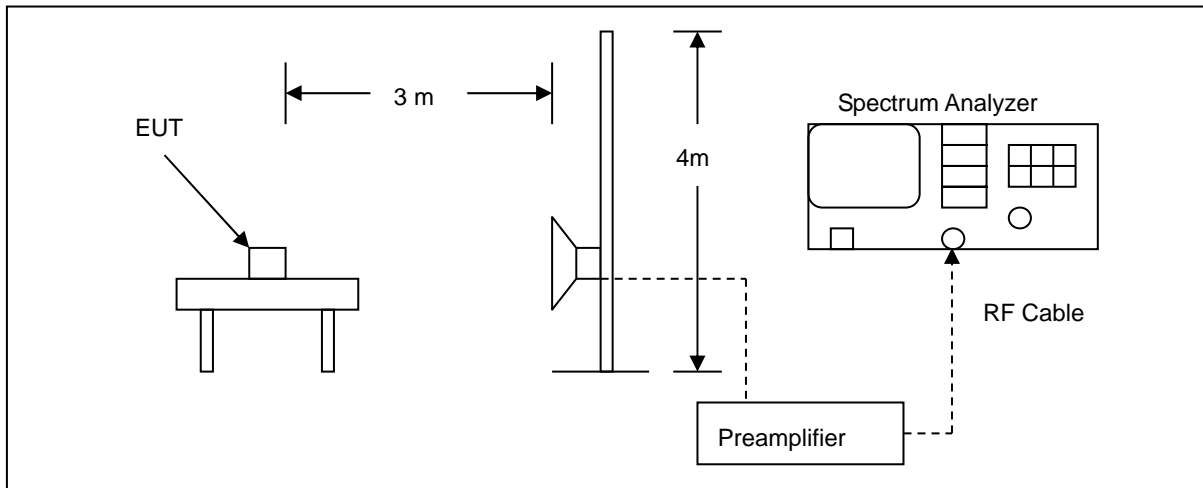

■ Test Procedure

The emissions on the harmonics frequencies, the limits, and the margin of compliance are presented. These tests were made when the transmitter was in full radiated power. The additional test was performed to show compliance with the requirement at the band-edge frequency 2483.5 MHz and up to 2500 MHz and at 2390.0 MHz.

The transmitter was configured with the worst case antenna and setup to transmit at the highest channel. Then the field strength was measured at 2483.5 MHz.

The transmitter was then configured with the worst case antenna and setup to transmit at the lowest channel. Then the field strength was measured at 2390.0 MHz. These tests were performed at 4 different bit rates.

For measurements the resolution bandwidth is set to 1 MHz, and then the video bandwidth is set to 1 MHz for peak measurements and 10 Hz for average measurements.

4.3. 20 dB Bandwidth Measurement

■ **Limit**

N/A

■ **Test Setup**

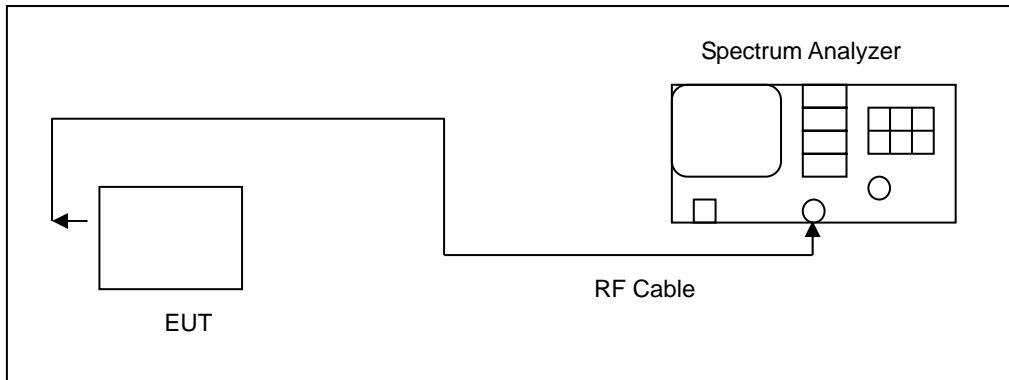

■ **Test Procedure**

The transmitter shall be operated at its maximum carrier power measured under normal test conditions.

The span of the analyzer shall be set to capture all products of the modulation process, including the emission skirts.

The resolution bandwidth shall be set to as close to 1 % of the selected span as is possible without being below 1 %.

The video bandwidth shall be set to 3 times the resolution bandwidth. Video averaging is not permitted. Where practical, a sampling detector shall be used since a peak or, peak hold, may produce a wider bandwidth than actual.

The trace data points are recovered and are directly summed in linear terms. The recovered amplitude data points, beginning at the lowest frequency, are placed in a running sum until 0.5 % of the total is reached and that frequency recorded. The process is repeated for the highest frequency data points. This frequency is recorded



4.4. Antenna Measurement

- **Limit**

For intentional device, according to 15.203, an intentional radiator shall be designed to ensure that no antenna other than that furnished by the responsible party shall be used with the device.

And According to 15.247 (b), if transmitting antennas of directional gain greater than 6 dBi are used, the power shall be reduced by the amount in dB that the directional gain of the antenna exceeds 6 dBi.

- **Antenna Connector Construction**

See section 2 – antenna information.



5 Test Results

Annex A. Conducted Test Results

20 dB Bandwidth Measurement

Test Mode	Mode 2	
Frequency (MHz)	20 dB RF Bandwidth (kHz)	Limit (MHz)
2404	1180	-----
2440	1216	-----
2478	1220	-----

■ Test Graphs

20 dB RF Bandwidth



Annex B. Radiated Emission Measurement

Fundamental

Standard:	FCC Part 15.249	Test Distance:	3 m
Test item:	Fundamental		
Test Mode:	Mode 2		
Frequency:	2404 MHz		
Ant.Polar.:	Horizontal		

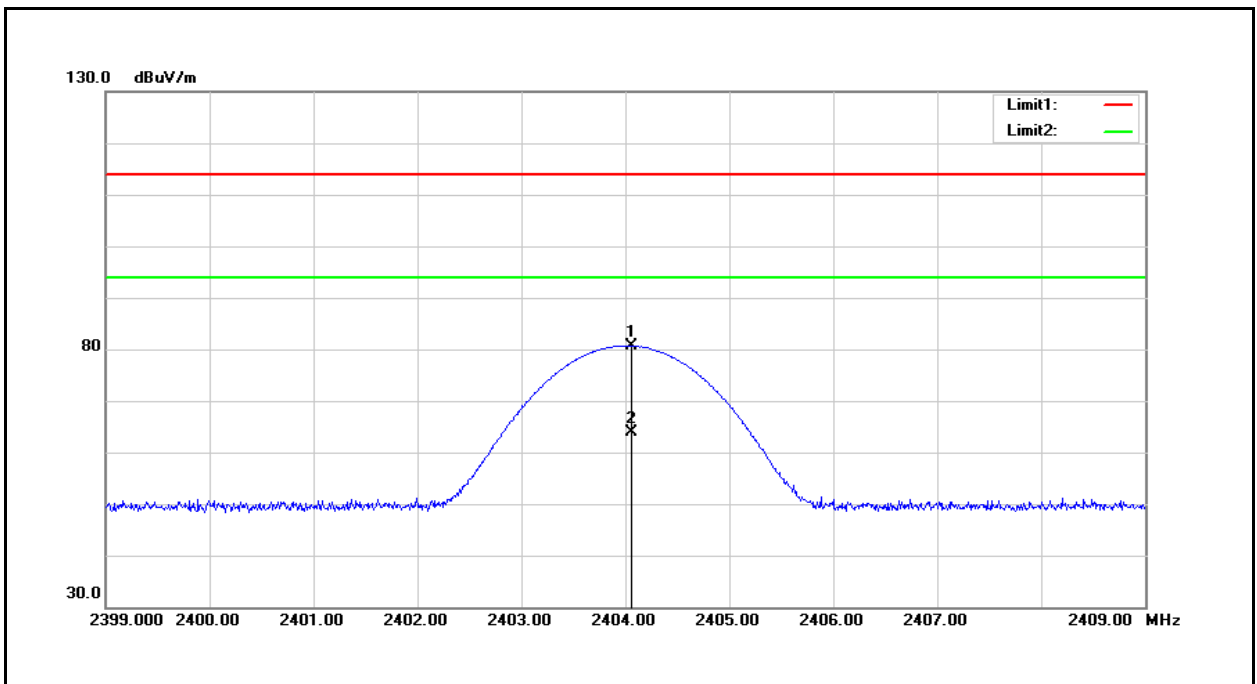

No.	Frequency (MHz)	Reading (dBuV)	Correct Factor (dB/m)	Result (dBuV/m)	Limit (dBuV/m)	Margin (dB)	Remark
1	2404.06	88.44	-7.7	80.74	114	-33.26	Peak
2	2404.06	80.74	-16.77	63.97	94	-30.03	AVG

Note:1.Result (dBuV/m) = Correct Factor (dB/m) + Reading(dBuV).

Example: 80.74= -7.7+88.44.

2.Correction factor (dB/m) = Antenna Factor (dB/m) + Cable loss (dB) – Pre-Amplifier gain (dB).

3.When the peak results are less than average limit, so not need to evaluate the average.



Standard:	FCC Part 15.249	Test Distance:	3 m
Test item:	Fundamental		
Test Mode:	Mode 2		
Frequency:	2404 MHz		
Ant.Polar.:	Vertical		

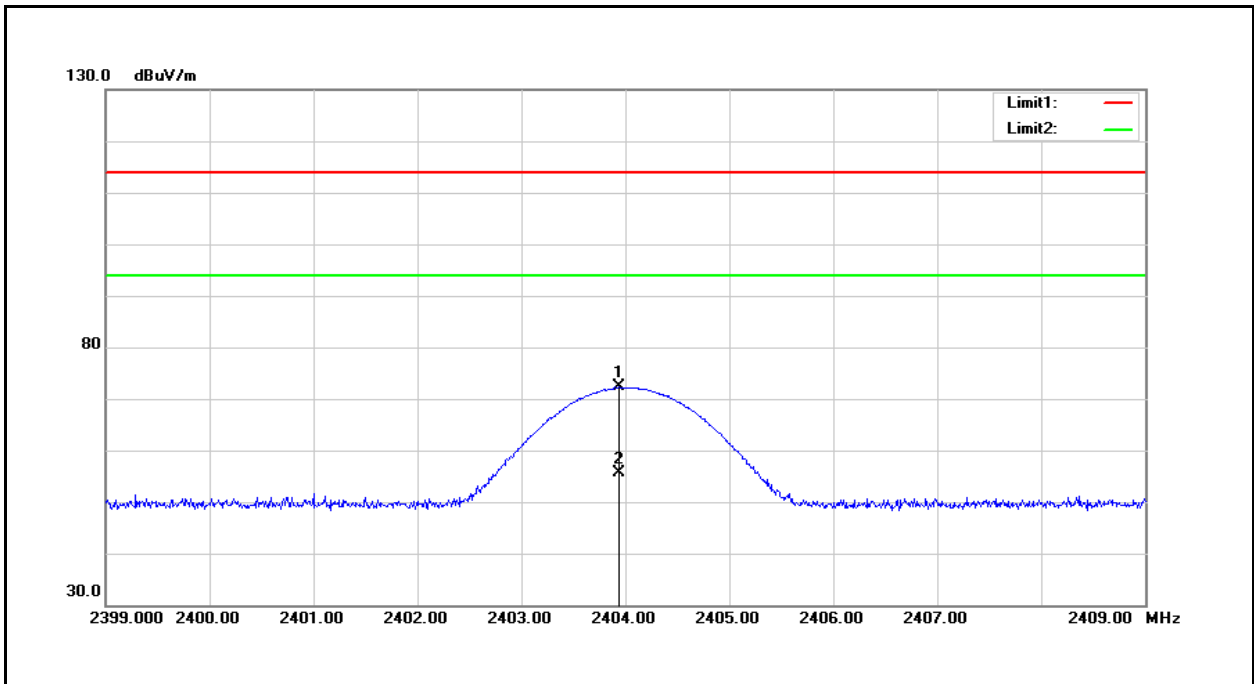

No.	Frequency (MHz)	Reading (dBuV)	Correct Factor (dB/m)	Result (dBuV/m)	Limit (dBuV/m)	Margin (dB)	Remark
1	2403.94	80.03	-7.7	72.33	114	-41.67	Peak
2	2403.94	72.33	-16.77	55.56	94	-38.44	AVG

Note:1.Result (dBuV/m) = Correct Factor (dB/m) + Reading(dBuV).

Example: 72.33= -7.7+80.03.

2.Correction factor (dB/m) = Antenna Factor (dB/m) + Cable loss (dB) – Pre-Amplifier gain (dB).

3.When the peak results are less than average limit, so not need to evaluate the average.



Standard:	FCC Part 15.249	Test Distance:	3 m
Test item:	Fundamental		
Test Mode:	Mode 2		
Frequency:	2440 MHz		
Ant.Polar.:	Horizontal		

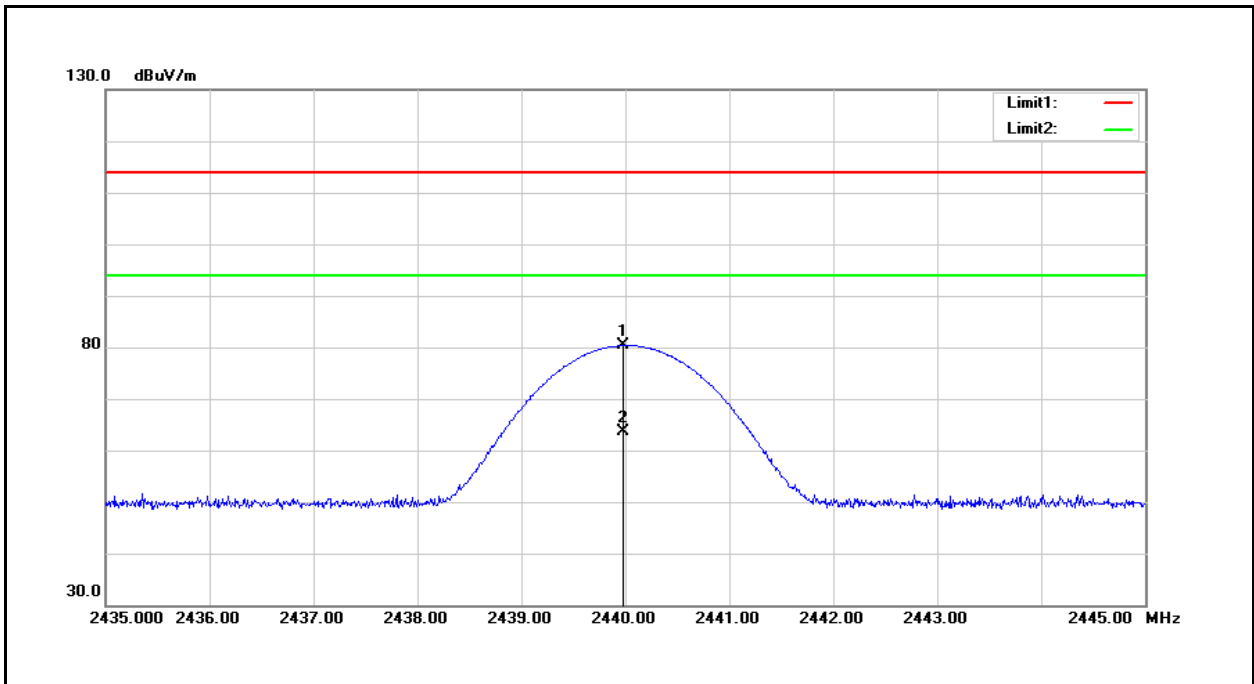

No.	Frequency (MHz)	Reading (dBuV)	Correct Factor (dB/m)	Result (dBuV/m)	Limit (dBuV/m)	Margin (dB)	Remark
1	2439.98	87.93	-7.53	80.4	114	-33.6	Peak
2	2439.98	80.4	-16.77	63.63	94	-30.37	AVG

Note:1.Result (dBuV/m) = Correct Factor (dB/m) + Reading(dBuV).

2.Correction factor (dB/m) = Antenna Factor (dB/m) + Cable loss (dB) – Pre-Amplifier gain (dB).

3.When the peak results are less than average limit, so not need to evaluate the average.



Standard:	FCC Part 15.249	Test Distance:	3 m
Test item:	Fundamental		
Test Mode:	Mode 2		
Frequency:	2440 MHz		
Ant.Polar.:	Vertical		

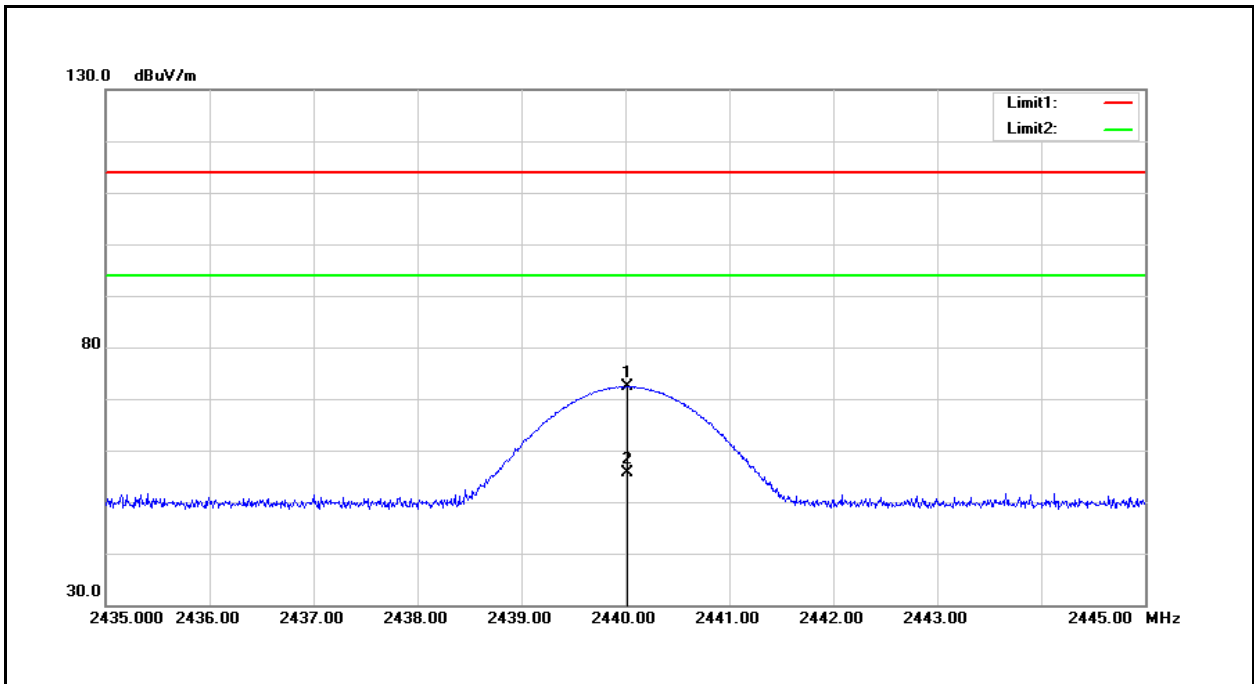

No.	Frequency (MHz)	Reading (dBuV)	Correct Factor (dB/m)	Result (dBuV/m)	Limit (dBuV/m)	Margin (dB)	Remark
1	2440.02	79.9	-7.53	72.37	114	-41.63	Peak
2	2440.02	72.37	-16.77	55.60	94	-38.40	AVG

Note: 1. Result (dBuV/m) = Correct Factor (dB/m) + Reading (dBuV).

2. Correction factor (dB/m) = Antenna Factor (dB/m) + Cable loss (dB) - Pre-Amplifier gain (dB).

3. When the peak results are less than average limit, so not need to evaluate the average.



Standard:	FCC Part 15.249	Test Distance:	3 m
Test item:	Fundamental		
Test Mode:	Mode 2		
Frequency:	2478 MHz		
Ant.Polar.:	Horizontal		

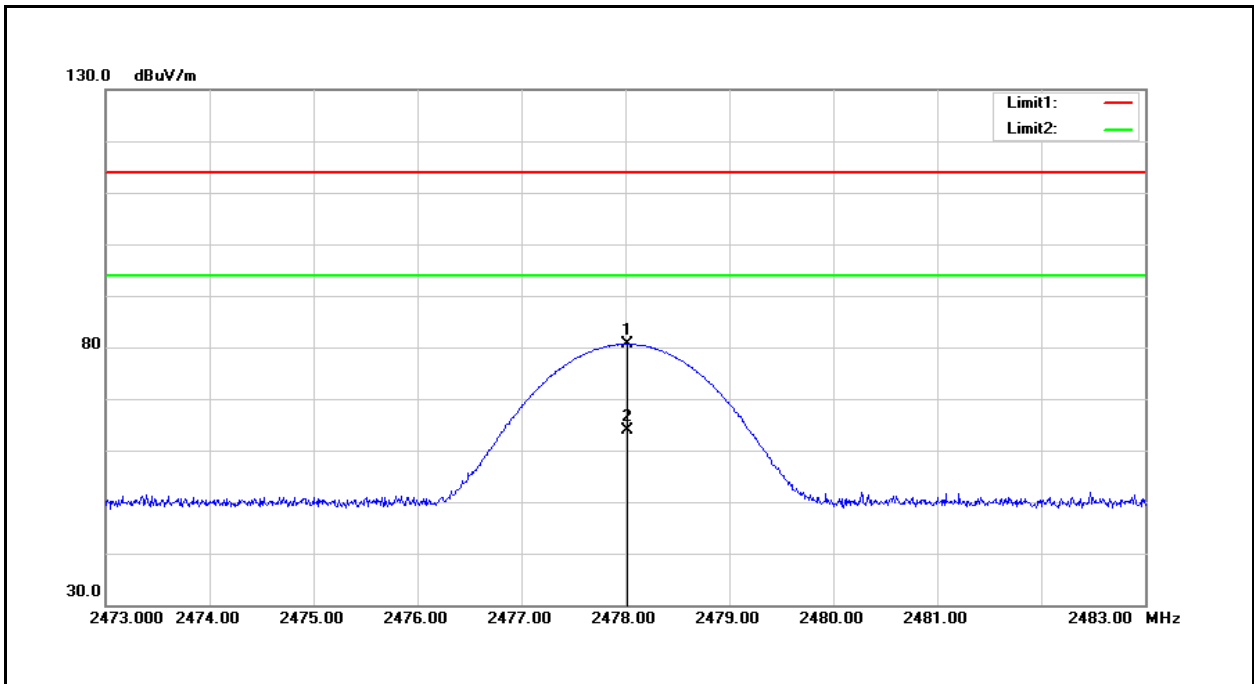

No.	Frequency (MHz)	Reading (dBuV)	Correct Factor (dB/m)	Result (dBuV/m)	Limit (dBuV/m)	Margin (dB)	Remark
1	2478.02	87.99	-7.37	80.62	114	-33.38	Peak
2	2478.02	80.62	-16.77	63.85	94	-30.15	AVG

Note:1.Result (dBuV/m) = Correct Factor (dB/m) + Reading(dBuV).

2.Correction factor (dB/m) = Antenna Factor (dB/m) + Cable loss (dB) – Pre-Amplifier gain (dB).

3.When the peak results are less than average limit, so not need to evaluate the average.



Standard:	FCC Part 15.249	Test Distance:	3 m
Test item:	Fundamental		
Test Mode:	Mode 2		
Frequency:	2478 MHz		
Ant.Polar.:	Vertical		

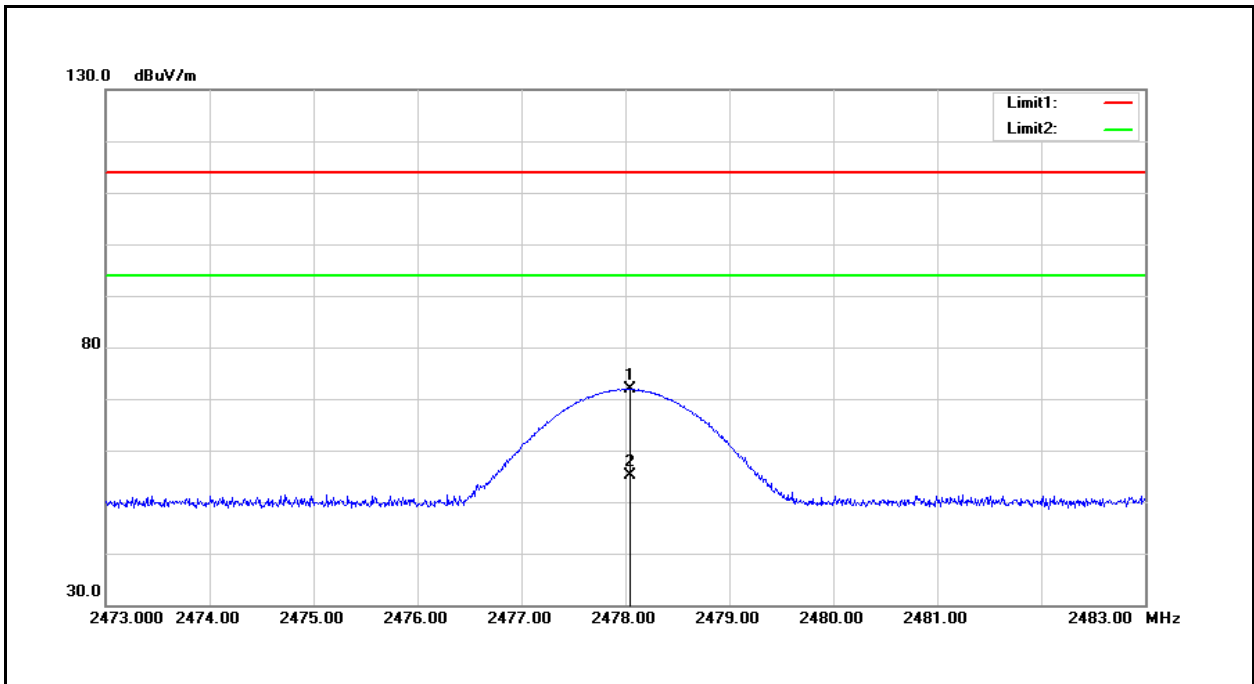

No.	Frequency (MHz)	Reading (dBuV)	Correct Factor (dB/m)	Result (dBuV/m)	Limit (dBuV/m)	Margin (dB)	Remark
1	2478.04	79.29	-7.37	71.92	114	-42.08	Peak
2	2478.04	71.92	-16.77	55.15	94	-38.85	AVG

Note:1.Result (dBuV/m) = Correct Factor (dB/m) + Reading(dBuV).

2.Correction factor (dB/m) = Antenna Factor (dB/m) + Cable loss (dB) – Pre-Amplifier gain (dB).

3.When the peak results are less than average limit, so not need to evaluate the average.



Below 1 GHz

Standard:	FCC Part 15.249	Test Distance:	3 m
Test item:	Radiated Emission		
Frequency:	2478 MHz		
Mode:	Mode 2		
Ant.Polar.:	Horizontal		

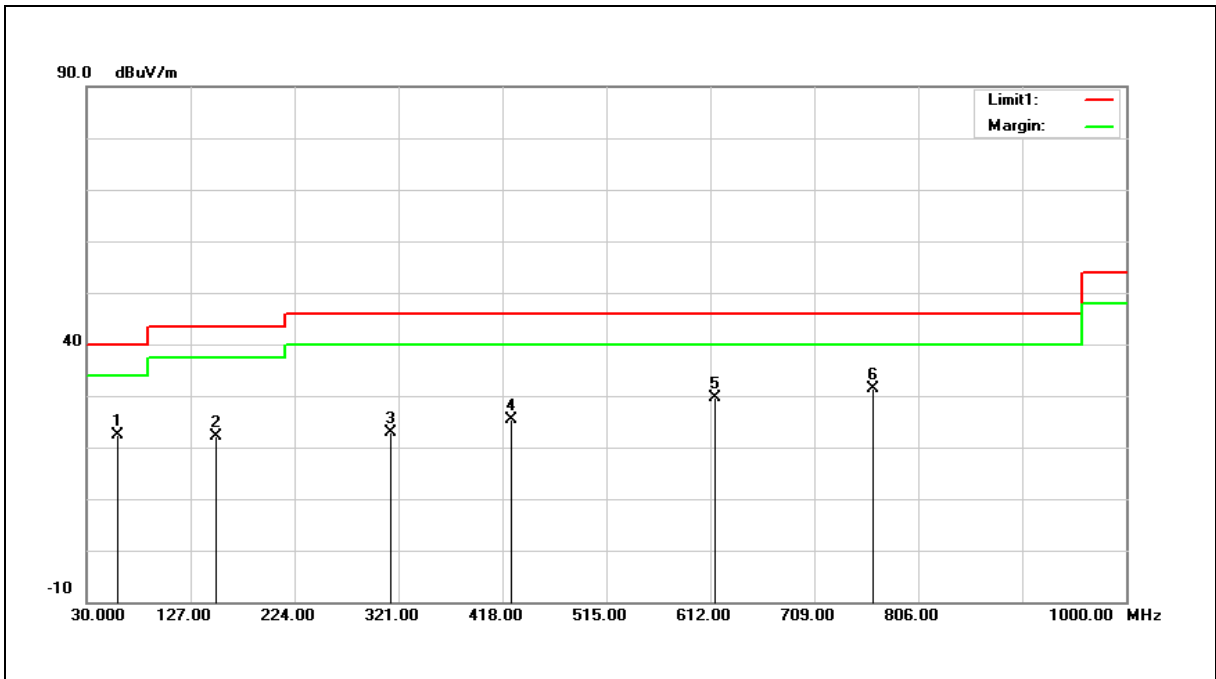

No.	Frequency (MHz)	Reading (dBuV)	Correct Factor (dB/m)	Result (dBuV/m)	Limit (dBuV/m)	Margin (dB)	Remark
1	59.1000	29.65	-7.18	22.47	40.00	-17.53	QP
2	150.2800	29.27	-7.02	22.25	43.50	-21.25	QP
3	313.2400	28.11	-5.30	22.81	46.00	-23.19	QP
4	425.7600	28.79	-3.33	25.46	46.00	-20.54	QP
5	616.8500	29.35	0.16	29.51	46.00	-16.49	QP
6	764.2900	29.01	2.26	31.27	46.00	-14.73	QP

Note:1.Result (dBuV/m) = Correct Factor (dB/m) + Reading(dBuV).

Example: 22.47 = -7.18 + 29.65.

2.Correction factor (dB/m) = Antenna Factor (dB/m) + Cable loss (dB) – Pre-Amplifier gain (dB).

3.When the peak results are less than average limit, so not need to evaluate the average.



Standard:	FCC Part 15.249	Test Distance:	3 m
Test item:	Radiated Emission		
Frequency:	2478 MHz		
Mode:	Mode 2		
Ant.Polar.:	Vertical		

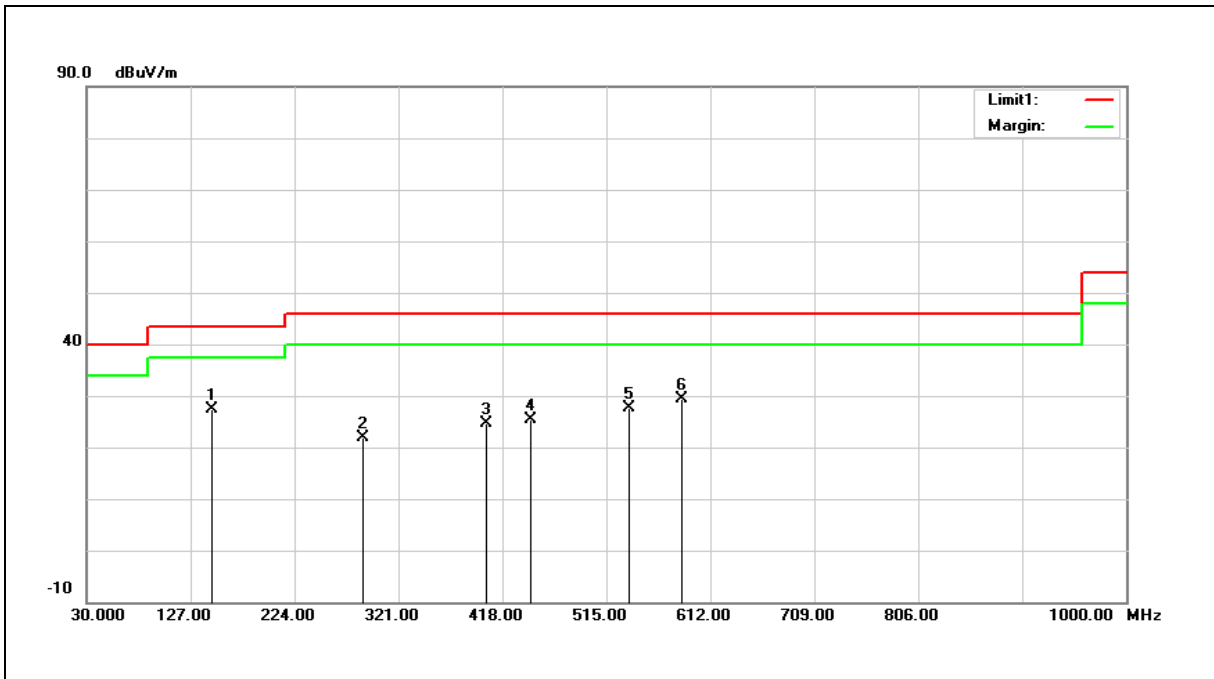

No.	Frequency (MHz)	Reading (dBuV)	Correct Factor (dB/m)	Result (dBuV/m)	Limit (dBuV/m)	Margin (dB)	Remark
1	147.3700	34.55	-7.16	27.39	43.50	-16.11	QP
2	288.0200	27.69	-5.81	21.88	46.00	-24.12	QP
3	403.4500	28.43	-3.74	24.69	46.00	-21.31	QP
4	444.1900	28.41	-3.00	25.41	46.00	-20.59	QP
5	536.3400	29.12	-1.51	27.61	46.00	-18.39	QP
6	585.8100	29.66	-0.32	29.34	46.00	-16.66	QP

Note:1.Result (dBuV/m) = Correct Factor (dB/m) + Reading(dBuV).

Example: 27.39 = -7.16 + 34.55.

2.Correction factor (dB/m) = Antenna Factor (dB/m) + Cable loss (dB) – Pre-Amplifier gain (dB).

3.When the peak results are less than average limit, so not need to evaluate the average.



Harmonic

Above 1 GHz

Standard:	FCC Part 15.249	Test Distance:	3 m
Test item:	Harmonic		
Frequency:	2404 MHz		
Mode:	Mode 2		
Ant.Polar.:	Vertical		

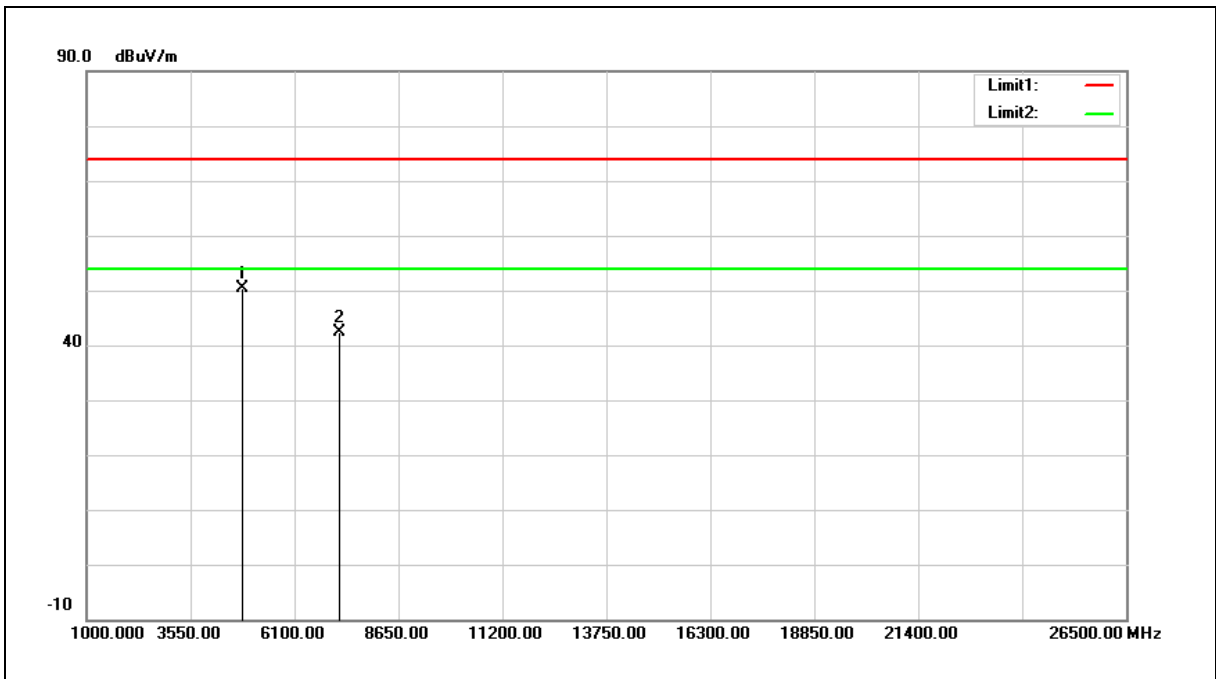

No.	Frequency (MHz)	Reading (dBuV)	Correct Factor (dB/m)	Result (dBuV/m)	Limit (dBuV/m)	Margin (dB)	Remark
1	4808.000	51.79	-1.46	50.33	74.00	-23.67	peak
2	7212.000	37.34	5.09	42.43	74.00	-31.57	peak

Note:1.Result (dBuV/m) = Correct Factor (dB/m) + Reading(dBuV).

2.Correction factor (dB/m) = Antenna Factor (dB/m) + Cable loss (dB) – Pre-Amplifier gain (dB).

3.When the peak results are less than average limit, so not need to evaluate the average.



Standard:	FCC Part 15.249	Test Distance:	3 m
Test item:	Harmonic		
Frequency:	2404 MHz		
Mode:	Mode 2		
Ant.Polar.:	Horizontal		

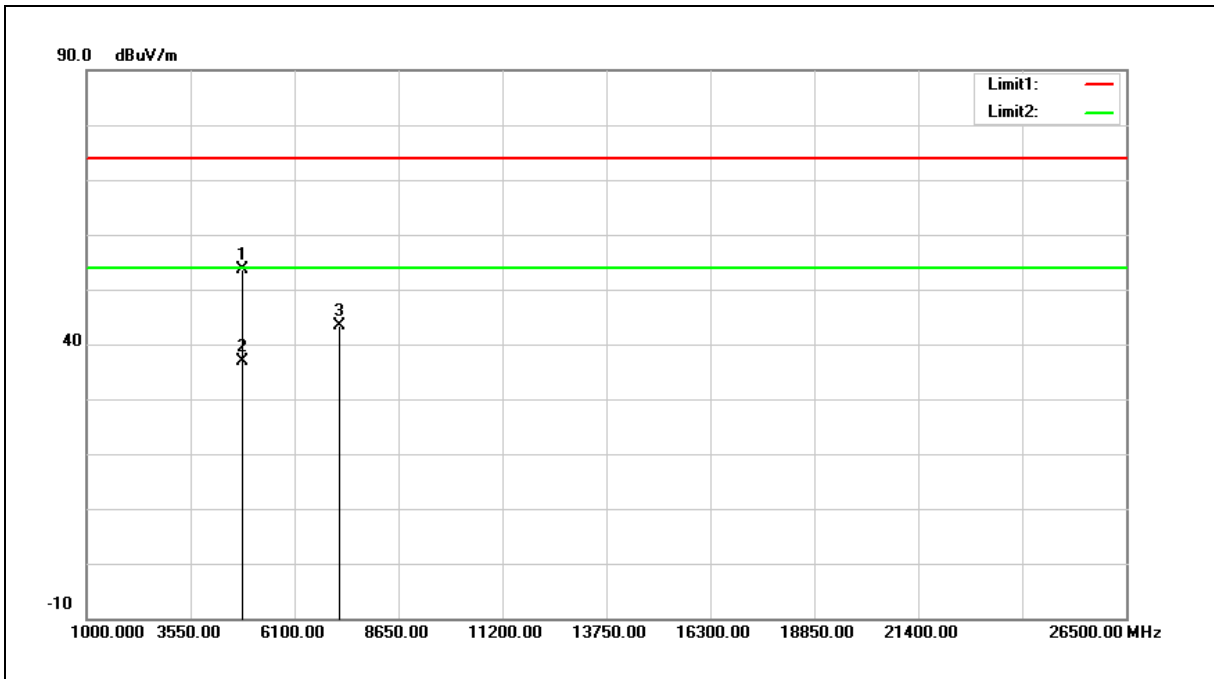

No.	Frequency (MHz)	Reading (dBuV)	Correct Factor (dB/m)	Result (dBuV/m)	Limit (dBuV/m)	Margin (dB)	Remark
1	4808.000	55.05	-1.46	53.59	74.00	-20.41	peak
2	4808.000	38.28	-1.46	36.82	54.00	-17.18	AVG
3	7212.000	38.38	5.09	43.47	74.00	-30.53	peak

Note:1.Result (dBuV/m) = Correct Factor (dB/m) + Reading(dBuV).

2.Correction factor (dB/m) = Antenna Factor (dB/m) + Cable loss (dB) – Pre-Amplifier gain (dB).

3.When the peak results are less than average limit, so not need to evaluate the average.



Standard:	FCC Part 15.249	Test Distance:	3 m
Test item:	Harmonic		
Frequency:	2440 MHz		
Mode:	Mode 2		
Ant.Polar.:	Horizontal		

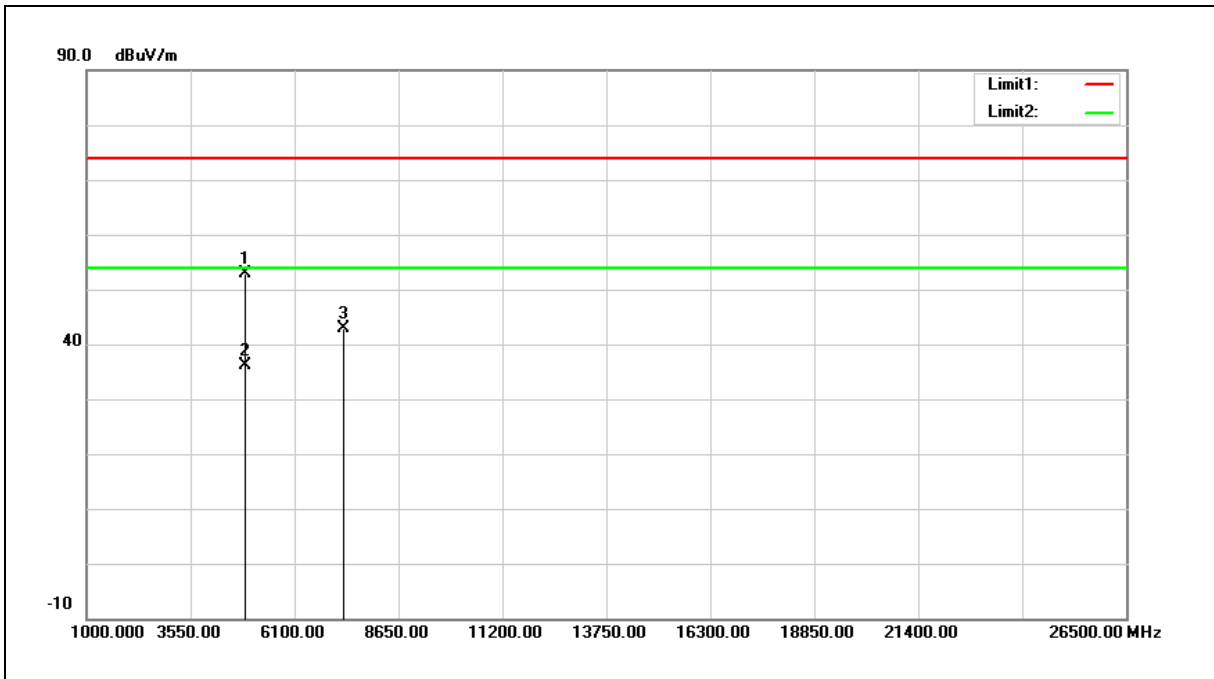

No.	Frequency (MHz)	Reading (dBuV)	Correct Factor (dB/m)	Result (dBuV/m)	Limit (dBuV/m)	Margin (dB)	Remark
1	4880.000	54.19	-1.28	52.91	74.00	-21.09	peak
2	4880.000	37.42	-1.28	36.14	54.00	-17.86	AVG
3	7320.000	37.52	5.39	42.91	74.00	-31.09	peak

Note:1.Result (dBuV/m) = Correct Factor (dB/m) + Reading(dBuV).

2.Correction factor (dB/m) = Antenna Factor (dB/m) + Cable loss (dB) – Pre-Amplifier gain (dB).

3.When the peak results are less than average limit, so not need to evaluate the average.



Standard:	FCC Part 15.249	Test Distance:	3 m
Test item:	Harmonic		
Frequency:	2440 MHz		
Mode:	Mode 2		
Ant.Polar.:	Vertical		

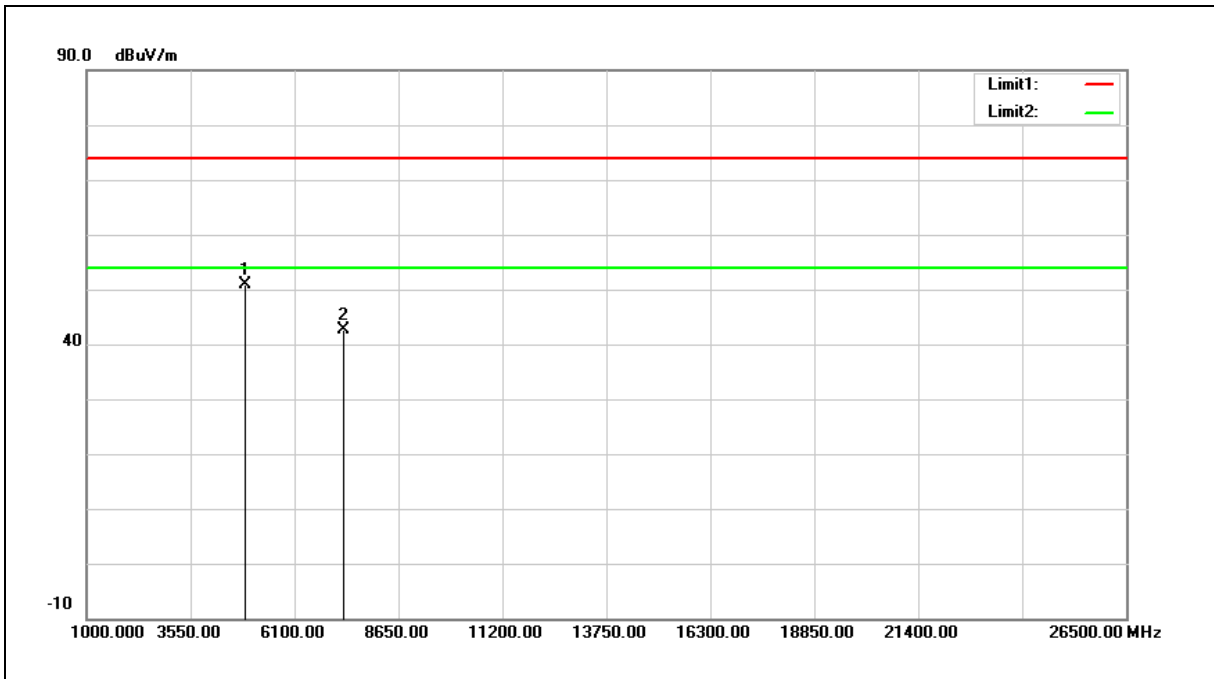

No.	Frequency (MHz)	Reading (dBuV)	Correct Factor (dB/m)	Result (dBuV/m)	Limit (dBuV/m)	Margin (dB)	Remark
1	4880.000	52.11	-1.28	50.83	74.00	-23.17	peak
2	7320.000	37.26	5.39	42.65	74.00	-31.35	peak

Note:1.Result (dBuV/m) = Correct Factor (dB/m) + Reading(dBuV).

2.Correction factor (dB/m) = Antenna Factor (dB/m) + Cable loss (dB) – Pre-Amplifier gain (dB).

3.When the peak results are less than average limit, so not need to evaluate the average.



Standard:	FCC Part 15.249	Test Distance:	3 m
Test item:	Harmonic		
Frequency:	2478 MHz		
Mode:	Mode 2		
Ant.Polar.:	Horizontal		

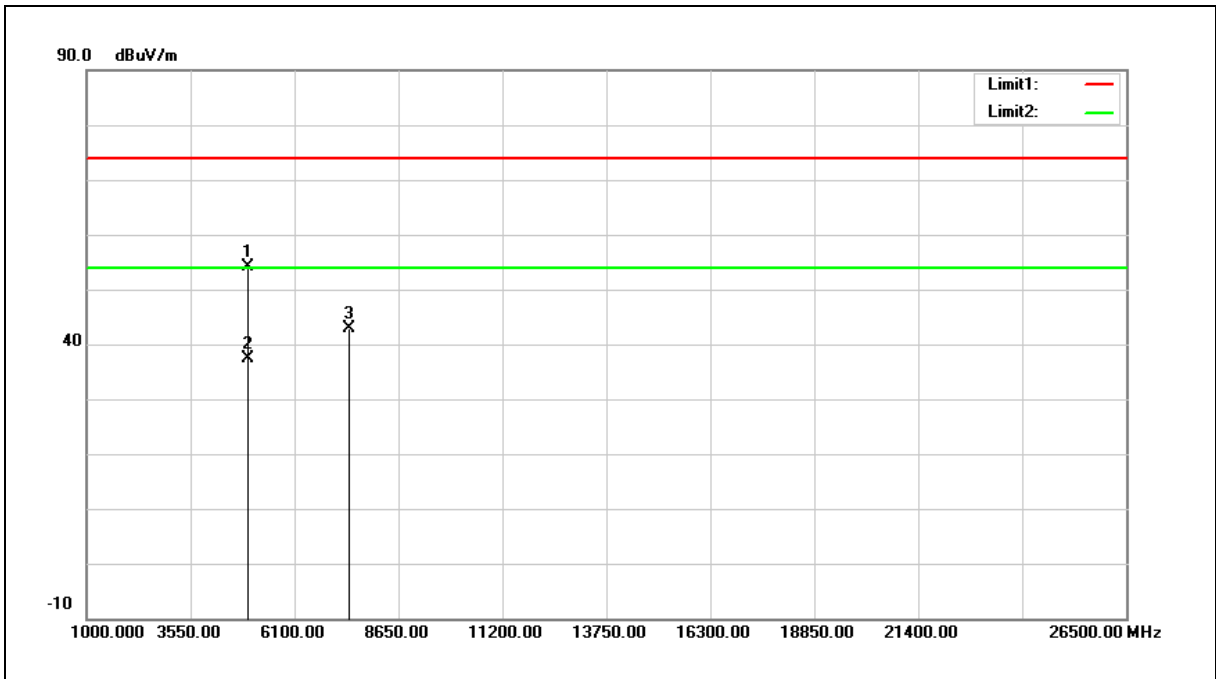

No.	Frequency (MHz)	Reading (dBuV)	Correct Factor (dB/m)	Result (dBuV/m)	Limit (dBuV/m)	Margin (dB)	Remark
1	4956.000	55.16	-1.08	54.08	74.00	-19.92	peak
2	4956.000	38.39	-1.08	37.31	54.00	-16.69	AVG
3	7434.000	37.07	5.70	42.77	74.00	-31.23	peak

Note:1.Result (dBuV/m) = Correct Factor (dB/m) + Reading(dBuV).

2.Correction factor (dB/m) = Antenna Factor (dB/m) + Cable loss (dB) – Pre-Amplifier gain (dB).

3.When the peak results are less than average limit, so not need to evaluate the average.



Standard:	FCC Part 15.249	Test Distance:	3 m
Test item:	Harmonic		
Frequency:	2478 MHz		
Mode:	Mode 2		
Ant.Polar.:	Vertical		

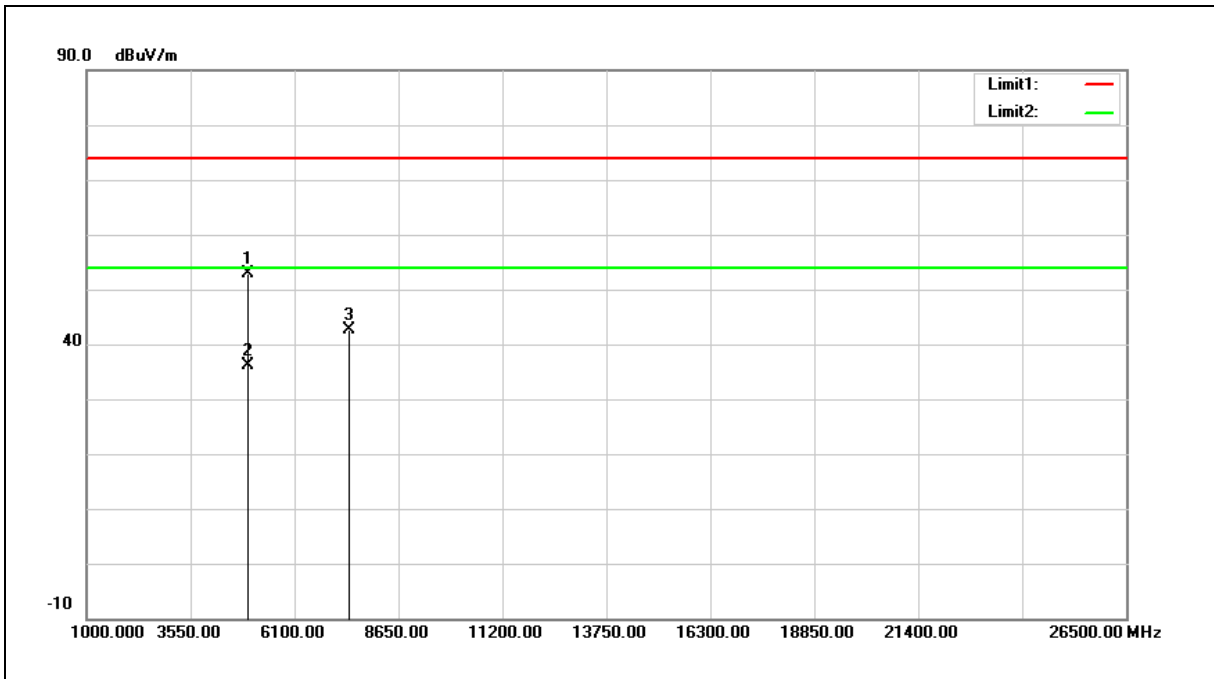

No.	Frequency (MHz)	Reading (dBuV)	Correct Factor (dB/m)	Result (dBuV/m)	Limit (dBuV/m)	Margin (dB)	Remark
1	4956.000	54.08	-1.08	53.00	74.00	-21.00	peak
2	4956.000	37.31	-1.08	36.23	54.00	-17.77	AVG
3	7434.000	36.90	5.70	42.60	74.00	-31.40	peak

Note:1.Result (dBuV/m) = Correct Factor (dB/m) + Reading(dBuV).

2.Correction factor (dB/m) = Antenna Factor (dB/m) + Cable loss (dB) – Pre-Amplifier gain (dB).

3.When the peak results are less than average limit, so not need to evaluate the average.



Band edge

Standard:	FCC Part 15.249	Test Distance:	3 m
Test item:	Band edge		
Frequency:	2404 MHz		
Mode:	Mode 2		
Ant.Polar.:	Horizontal		

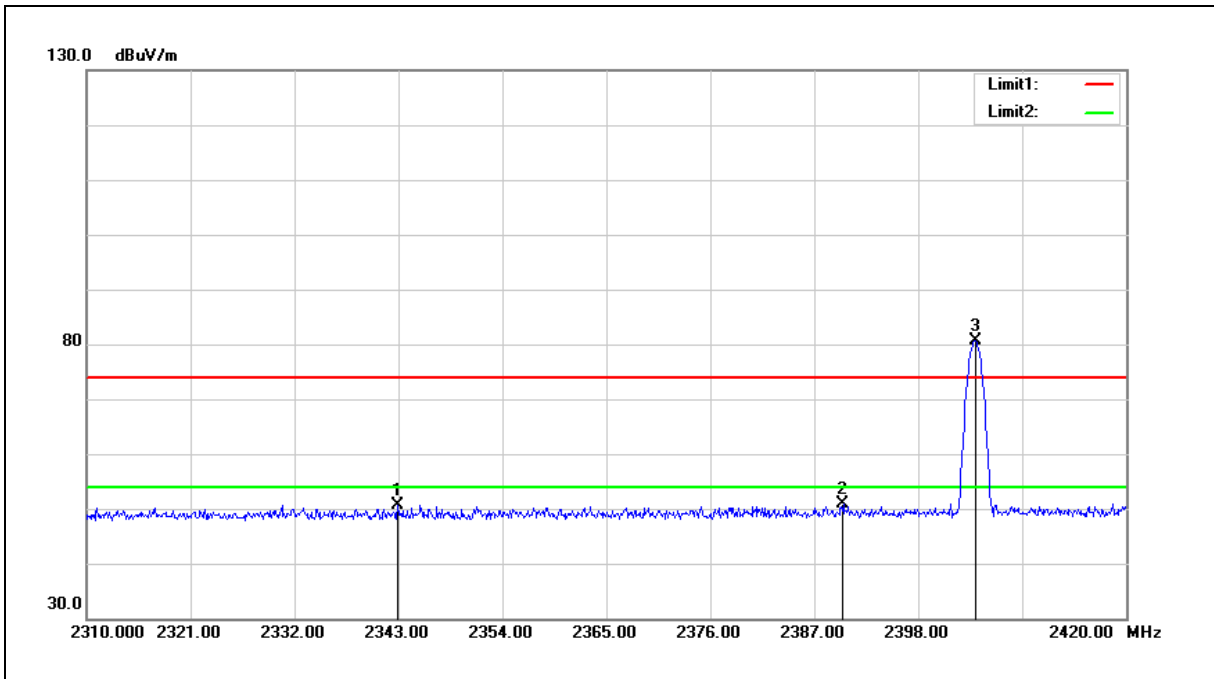

No.	Frequency (MHz)	Reading (dBuV)	Correct Factor (dB/m)	Result (dBuV/m)	Limit (dBuV/m)	Margin (dB)	Remark
1	2342.890	58.55	-7.97	50.58	74.00	-23.42	peak
2	2390.000	58.61	-7.76	50.85	74.00	-23.15	peak
3	2404.050	88.23	-7.70	80.53	--	--	peak

Note:1.Result (dBuV/m) = Correct Factor (dB/m) + Reading(dBuV).

2.Correction factor (dB/m) = Antenna Factor (dB/m) + Cable loss (dB) – Pre-Amplifier gain (dB).

3.When the peak results are less than average limit, so not need to evaluate the average.



Standard:	FCC Part 15.249	Test Distance:	3 m
Test item:	Band edge		
Frequency:	2404 MHz		
Mode:	Mode 2		
Ant.Polar.:	Vertical		

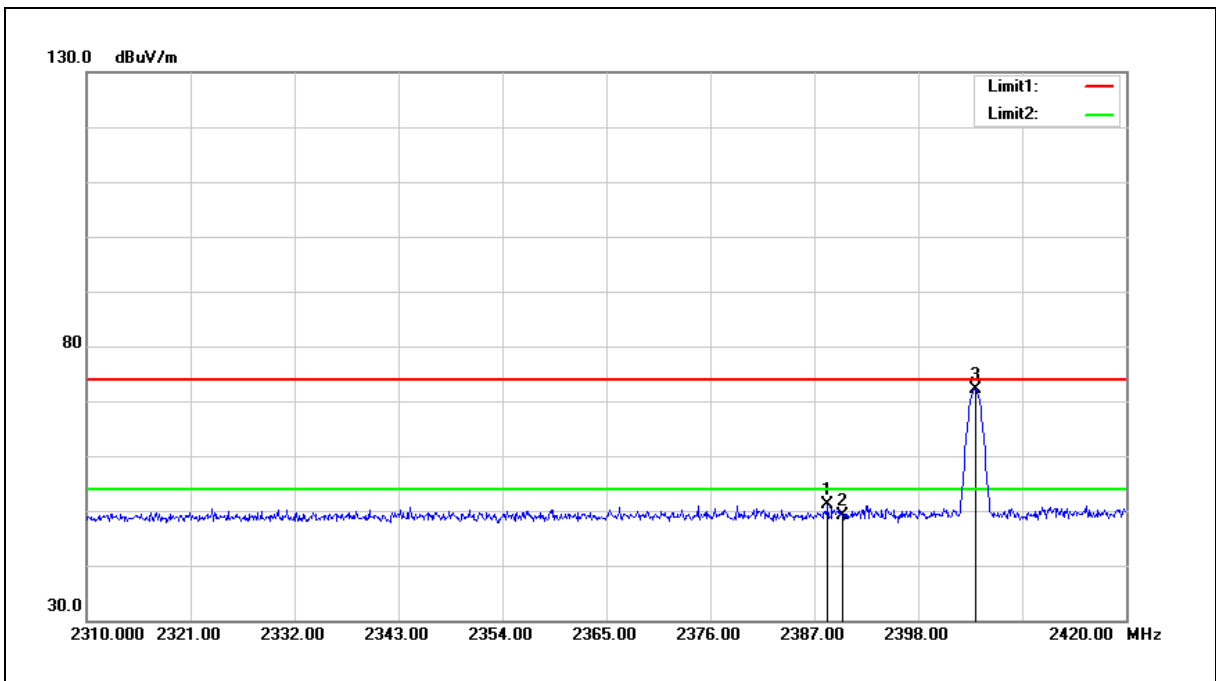

No.	Frequency (MHz)	Reading (dBuV)	Correct Factor (dB/m)	Result (dBuV/m)	Limit (dBuV/m)	Margin (dB)	Remark
1	2388.430	58.86	-7.77	51.09	74.00	-22.91	peak
2	2390.000	56.79	-7.76	49.03	74.00	-24.97	peak
3	2404.050	79.87	-7.70	72.17	--	--	peak

Note:1.Result (dBuV/m) = Correct Factor (dB/m) + Reading(dBuV).

2.Correction factor (dB/m) = Antenna Factor (dB/m) + Cable loss (dB) – Pre-Amplifier gain (dB).

3.When the peak results are less than average limit, so not need to evaluate the average.



Standard:	FCC Part 15.249	Test Distance:	3 m
Test item:	Band edge		
Frequency:	2478 MHz		
Mode:	Mode 2		
Ant.Polar.:	Horizontal		

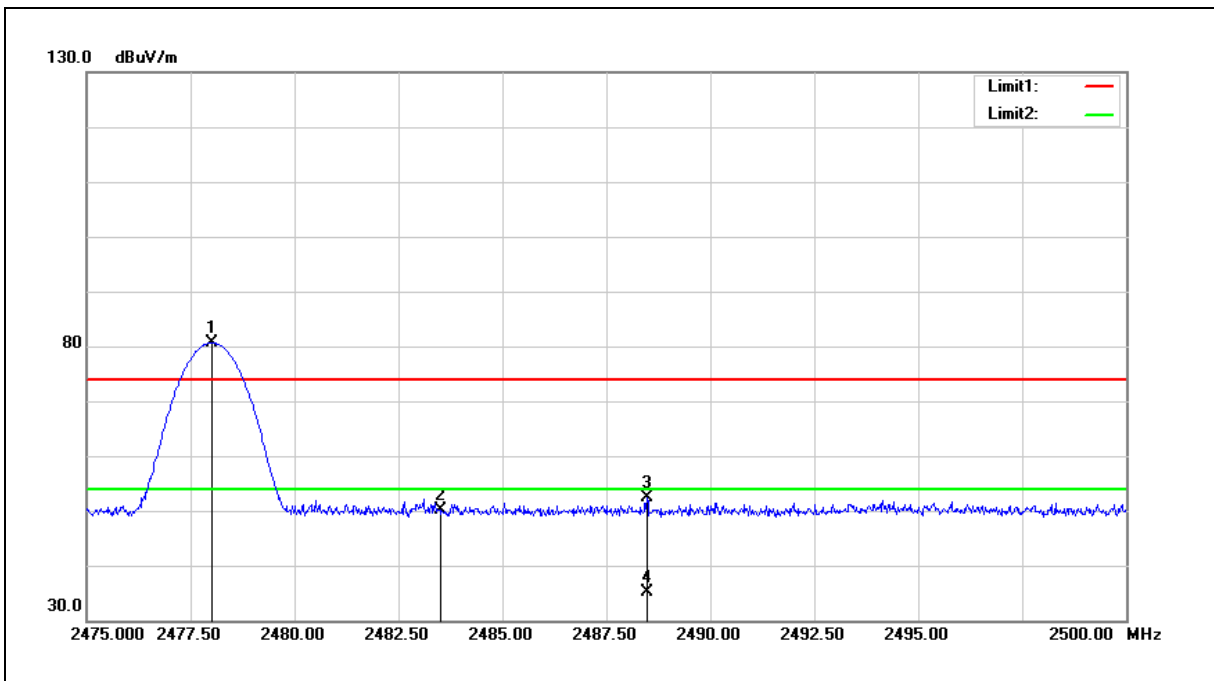

No.	Frequency (MHz)	Reading (dBuV)	Correct Factor (dB/m)	Result (dBuV/m)	Limit (dBuV/m)	Margin (dB)	Remark
1	2478.000	88.00	-7.37	80.63	--	--	peak
2	2483.500	57.44	-7.35	50.09	74.00	-23.91	peak
3	2488.475	59.67	-7.32	52.35	74.00	-21.65	peak
4	2488.475	42.57	-7.32	35.25	54.00	-18.75	AVG

Note:1.Result (dBuV/m) = Correct Factor (dB/m) + Reading(dBuV).

2.Correction factor (dB/m) = Antenna Factor (dB/m) + Cable loss (dB) – Pre-Amplifier gain (dB).

3.When the peak results are less than average limit, so not need to evaluate the average.



Standard:	FCC Part 15.249	Test Distance:	3 m
Test item:	Band edge		
Frequency:	2478 MHz		
Mode:	Mode 2		
Ant.Polar.:	Vertical		

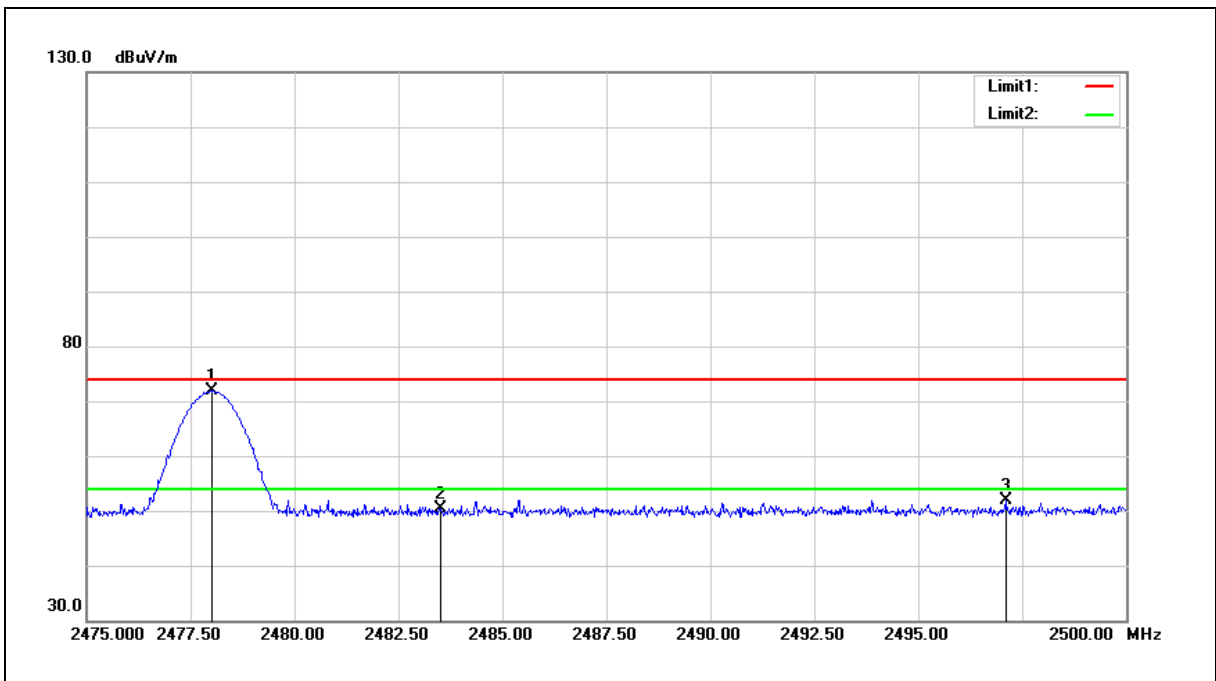

No.	Frequency (MHz)	Reading (dBuV)	Correct Factor (dB/m)	Result (dBuV/m)	Limit (dBuV/m)	Margin (dB)	Remark
1	2478.000	79.19	-7.37	71.82	--	--	peak
2	2483.500	57.63	-7.35	50.28	74.00	-23.72	peak
3	2497.100	59.15	-7.28	51.87	74.00	-22.13	peak

Note:1.Result (dBuV/m) = Correct Factor (dB/m) + Reading(dBuV).

2.Correction factor (dB/m) = Antenna Factor (dB/m) + Cable loss (dB) – Pre-Amplifier gain (dB).

3.When the peak results are less than average limit, so not need to evaluate the average.

---END---