



SCHRADER ELECTRONICS.LTD..
MODEL :SCHEB

USER MANUAL

The TPMS Transmitter is installed to the valve body in each tyre of a vehicle. The unit measures tyre pressure periodically and transmits this information by RF communication to a receiver inside the vehicle. In addition, the TPMS Transmitter performs the following functions:

- Determines a temperature compensated pressure value.
- Determines any abnormal pressure variations in the wheel.
- Monitors the state of the Transmitters' internal battery and informs the receiver of a low battery condition.

Fig 1: Sensor block diagram

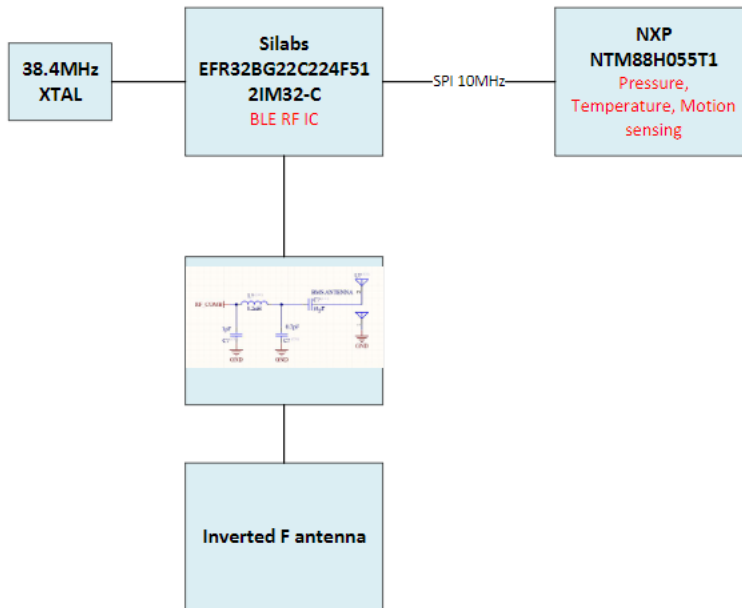
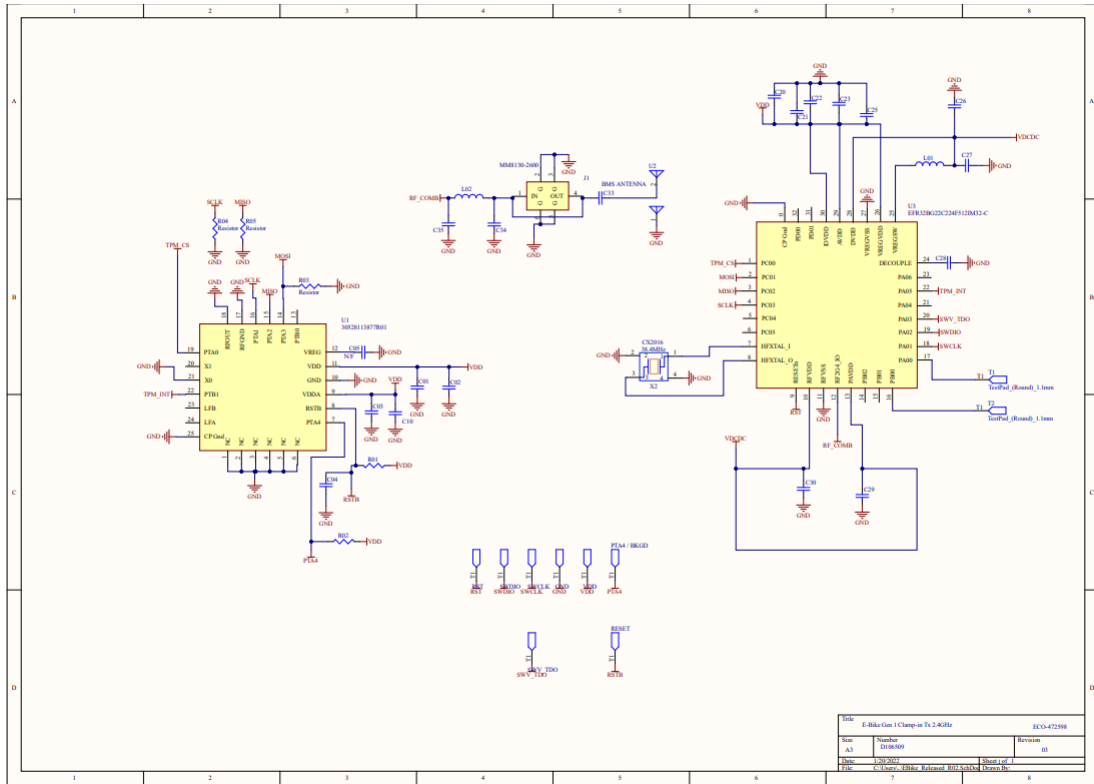

Fig 2: Schematic diagram

(Please see SCHEB Circuit Schematic File.)



Modes

Rotating Mode

While the sensor/transmitter in the Rotating Mode, it shall satisfy the following requirements. The sensor/transmitter shall transmit an instantaneous measured data, if a pressure change of 2.0 psi from the last transmission or greater has occurred with respect to the following conditions. If the pressure change was a decrease of pressure, the sensor/transmitter shall transmit immediately every time it detects the 2.0-psi or greater pressure changes from the last transmission.

If the pressure change of 2.0 psi or greater was an increase of pressure, the sensor shall not react to it.

Stationary Mode

While the sensor/transmitter in the Stationary Mode, it shall satisfy the following requirements. The sensor/transmitter shall transmit an instantaneous measured data, if a pressure change of 2.0 psi from the last transmission or greater has occurred with respect to the following conditions. If the pressure change was a decrease of

pressure, the sensor/transmitter shall transmit immediately every time it detects the 2.0-psi or greater pressure changes from the last transmission.

If the pressure change of 2.0 psi or greater was an increase of pressure, the silent period between the RPC transmission and the last transmission shall be 30.0 seconds, and the silent period between the RPC transmission and the next transmission (Normal scheduled transmission or another RPC transmission) shall also be 30.0 seconds, to be in compliance of FCC Part 15.231.

Factory Mode

The factory mode is the mode that the sensor shall transmit more often in the factory to assure the programmability of the sensor ID during the manufacturing process.

Off Mode

This Off Mode is only for production parts sensors that are used for the builds during the production process and not in the service environment.

LF Initiation

The sensor/transmitter must provide data upon the presence of an LF signal. The sensor must react (Transmit and provide data) no later than 150.0 ms after the LF data code has been detected at the sensor. The sensor/transmitter must be sensitive (As sensitivity is defined in Table 1) and able to detect the LF field.