



BNetzA-CAB-21/21-21

Test Report

Test report no.: 24050180-41266-1

Date of issue: 2024-11-04

Test result: The test item - **passed** - and complies with below listed standards.

Applicant

Schrader Electronics Ltd.

Manufacturer

Schrader Electronics Ltd.

Test Item

ETMS02

RF-Spectrum Testing

according to:

FCC 47 CFR Part 15

Radio Frequency Devices – Subpart C

§ 15.247 Operation within the bands 902–928 MHz, 2400–2483.5 MHz, and 5725–5850 MHz

RSS-247, Issue 3 (2023-08)

Digital Transmission Systems (DTSs), Frequency Hopping Systems (FHSs) and Licence-Exempt Local Area Network (LE-LAN) Devices

RSS-Gen, Issue 5 (2018-04)

General Requirements for Compliance of Radio Apparatus

Tested by
(name, function, signature)

Karsten Gerald
Lab Manager RF

signature

Approved by
(name, function, signature)

Andreas Bender
Deputy Managing Director

signature

Applicant and Test item details	
Applicant	Schrader Electronics Ltd. Unit 11, Antrim Technology Pk, Belfast Rd. BT1 1QS, Antrim, Northern Ireland, UK
Manufacturer No. 1	Schrader Electronics Ltd. Unit 11, Antrim Technology Pk, Belfast Rd. BT1 1QS, Antrim, Northern Ireland, UK
Manufacturer No. 2	Sensata Technologies China Co., Ltd. 18 Chuangxin Avenue, Xinbei District Changzhou 213031, PRC
Manufacturer No. 3	Sensata Technologies de Mexico S de RL de CV Av. Aguascalientes Sur # 401 Ex Ejido Salto de Ojocaliente, CP. 20290 Aguascalientes, Mexico
Test item description	Tyre Pressure Sensor (TPMS) with a wireless transmission at 2.4 GHz using Bluetooth Low Energy (BLE). Intended for the automotive industry.
Model/Type reference	ETMS02
Standard specific information	
FCC ID	MRXETMS02
IC	2546A-ETMS02
HMN	N/A
PMN	ETMS02
HVIN	ETMS02
FVIN	N/A
Technology	Bluetooth Low Energy (BLE)
Frequency	2.4 GHz ISM band (2400 – 2483.5 MHz)
Antenna	Goal Post Antenna (0.4 dBi)
Power supply	3.0 V DC via battery (CR2032HR)
Temperature range	-40 °C – +120 °C

Disclaimer and Notes

The content of this report relates to the mentioned test sample(s) only.
IBL-Lab GmbH does not take samples. The samples used for testing are provided by the applicant.
Without a written permit of IBL-Lab GmbH, this test report shall not be reproduced, except in full.

The last valid version is available at [TAMSys®](#).

Signatures are done electronically, if signer does not match stated signer, it is signed per order.
Information supplied by the applicant can affect the validity of results. The data is marked accordingly.

Copyright ©: All rights reserved by IBL-Lab GmbH

Within this test report, a ☒ point / □ comma is used as a decimal separator.
If otherwise, a detailed note is added adjected to its use.

Decision rule:

Decision rule based on simple acceptance without guard bands, binary statement, based on mutually agreed uncertainty tolerances with expansion factor k=2 according to ILAC-G8:09/2019

1 TABLE OF CONTENTS

1	TABLE OF CONTENTS	3
2	GENERAL INFORMATION	4
2.1	Administrative details	4
2.2	Possible test case verdicts	5
2.3	Observations	5
2.4	Opinions and interpretations	5
2.5	Revision history	5
2.6	Further documents	5
3	ENVIRONMENTAL & TEST CONDITIONS	6
3.1	Environmental conditions	6
3.2	Normal and extreme test conditions	6
4	TEST STANDARDS AND REFERENCES	6
5	EQUIPMENT UNDER TEST (EUT)	7
5.1	Product Description	7
5.2	Test Item Description	7
5.3	Technical Data of Equipment	7
5.4	Additional Information	7
5.5	Test modes	8
6	SUMMARY OF TEST RESULTS	9
7	TEST RESULTS	10
7.1	DTS Bandwidth (6 dB)	10
7.2	Occupied Bandwidth (99% OBW)	13
7.3	RF Output Power (Conducted Peak Power)	16
7.4	Antenna Gain	19
7.5	Peak Power Spectral Density (PSD)	20
7.6	Band Edge Compliance (BEC), conducted	23
7.7	Band Edge Compliance (BEC), radiated	27
7.8	Conducted Spurious Emissions (CSE)	30
7.9	Radiated Spurious Emissions (RSE)	35
8	TEST SETUP DESCRIPTION	47
8.1	Semi Anechoic Chamber with Ground Plane	48
8.2	Fully Anechoic Chamber	50
8.3	Radiated measurements > 18 GHz	52
8.4	Conducted measurements WLAN test system R&S TS 8997	53
9	MEASUREMENT PROCEDURES	54
9.1	Radiated spurious emissions from 9 kHz to 30 MHz	54
9.2	Radiated spurious emissions from 30 MHz to 1 GHz	55
9.3	Radiated spurious emissions from 1 GHz to 18 GHz	56
9.4	Radiated spurious emissions above 18 GHz	57
10	MEASUREMENT UNCERTAINTIES	58
Annex A	EUT Photographs, external	59
Annex B	EUT Photographs, internal	61
Annex C	Test Setup Photographs	65

2 GENERAL INFORMATION

2.1 Administrative details

Testing laboratory	<p>IBL-Lab GmbH Heinrich-Hertz-Allee 7 66386 St. Ingbert / Germany Fon: +49 6894 38938-0 Fax: +49 6894 38938-99 URL: https://ib-lenhardt.com/ E-Mail: info@ib-lenhardt.com</p>
Accreditation / Designation	<p>The testing laboratory is accredited by Deutsche Akkreditierungsstelle GmbH (DAkkS) in compliance with DIN EN ISO/IEC 17025:2018.</p> <p>Scope of testing and registration number:</p> <ul style="list-style-type: none"> • Attachment to the accreditation certificate D-PL-21375-01-00 <ul style="list-style-type: none"> ○ Electronics ○ Electromagnetic Compatibility ○ Radio ○ Electromagnetic Compatibility and Telecommunication (FCC requirements) ○ Telecommunication (TC) and Electromagnetic Compatibility (EMC) for Canadian Standards ○ Automotive EMC <p>Website DAkkS: https://www.dakks.de/ The Deutsche Akkreditierungsstelle GmbH (DAkkS) is also a signatory to the ILAC Mutual Recognition Arrangement.</p> <ul style="list-style-type: none"> • Designations <ul style="list-style-type: none"> ○ FCC Testing Laboratory Designation Number DE0024 ○ ISED ISED Company Number 27156 Testing Laboratory CAB Identifier DE0020 ○ Krafftahrt-Bundesamt KBA-P 00120-23
Testing location	<p>IBL-Lab GmbH Heinrich-Hertz-Allee 7 66386 St. Ingbert / Germany</p>
Date of receipt of test samples	2024-10-07
Start – End of tests	2024-10-07 – 2024-10-21

2.2 Possible test case verdicts

Test sample meets the requirements	P (PASS) – the measured value is below the acceptance limit, AL = TL
Test sample does not meet the requirements	F (FAIL) – the measured value is above the acceptance limit, AL = TL
Test case does not apply to the test sample	N/A (Not applicable)
Test case not performed	N/P (Not performed)

2.3 Observations

No additional observations other than the reported observations within this test report have been made.

2.4 Opinions and interpretations

No appropriate opinions or interpretations according ISO/IEC 17025:2017 clause 7.8.7 are within this test report.

2.5 Revision history

-0 Initial Version

-1 Revision: HVIN changed according to applicant's requirements

2.6 Further documents

List of further applicable documents belonging to the present test report:
– no additional documents –

3 ENVIRONMENTAL & TEST CONDITIONS

3.1 Environmental conditions

Temperature	20°C ± 5°C
Relative humidity	25-75 % r.H.
Barometric Pressure	860-1060 mbar
Power supply	230 V AC ± 5%

3.2 Normal and extreme test conditions

	minimum	nominal	maximum
Temperature	-/- °C	20 °C	-/- °C
Relative humidity	-/-	45 % r.h.	-/-
Power supply	-/- V DC	3.0 V DC	-/- V DC

4 TEST STANDARDS AND REFERENCES

Test standard (accredited)	Description
FCC 47 CFR Part 15	Radio Frequency Devices – Subpart C § 15.247 Operation within the bands 902–928 MHz, 2400–2483.5 MHz, and 5725–5850 MHz
RSS-247, Issue 3 (2023-08)	Digital Transmission Systems (DTSS), Frequency Hopping Systems (FHSs) and Licence-Exempt Local Area Network (LE-LAN) Devices
RSS-Gen, Issue 5 (2018-04)	General Requirements for Compliance of Radio Apparatus

Reference	Description
ANSI C63.4-2014	American National Standard for Methods of Measurement of Radio-Noise Emissions from Low-Voltage Electrical and Electronic Equipment in the Range of 9 kHz to 40 GHz
ANSI C63.10-2013	American National Standard of Procedures for Compliance Testing of Unlicensed Wireless Devices
558074 D01 15.247 Meas Guide v05r02	Guidance for compliance measurements on digital transmission systems, frequency hopping spread spectrum systems and hybrid system devices operating under section 15.247 of the FCC rules

5 EQUIPMENT UNDER TEST (EUT)

5.1 Product Description

Tyre Pressure Sensor (TPMS) with a wireless transmission at 2.4 GHz using Bluetooth Low Energy (BLE). Intended for the automotive industry.

*: as declared by applicant

5.2 Test Item Description

Model name*	ETMS02
Serial number*	C2-Sample
Hardware status*	V3
Software status*	V5.3

*: as declared by applicant

5.3 Technical Data of Equipment

Technology*	Bluetooth Low Energy (BLE)
Operational frequency band*	2.4 GHz ISM band (2400 – 2483.5 MHz)
Operational carrier frequency*	2402 – 2480 MHz
Modulation type*	GFSK
Data rate*	LE 1M PHY: 1 Mbit/s
Number of channels*	40 (3 advertising channels, 37 data channels)
Channel bandwidth*	2 MHz
Channel spacing*	2 MHz
Antenna*	Goal Post Antenna (0.4 dBi)
Antenna gain*	0.4
Power supply*	3.0 V DC via battery (CR2032HR)
Temperature range*	-40 °C – +120 °C

*: as declared by applicant

5.4 Additional Information

Model differences	– none –
Ancillaries tested with	– none –
Additional equipment used for testing	notebook with test software as prepared by applicant

Note:

The manufacturer declared following:

There are two primary operating modes for this product, standard BLE Bluetooth Core Specification mode 1 Mbps PHY and special High-Power Advertising (HPA).

The standard 1Mbps PHY is not protocol-limited and it will use a power setting of +4dBm (max).

The HPA mode is restricted in operation. Under no condition can it be changed or modified by either the device or the end-user. The HPA mode employs 1Mbps PHY with a duty cycle limited to 50% and a power setting of +6dBm (max).

5.5 Test modes	
Mode 1	GFSK, 1 Mbit/s, Tx power = 6 dBm, DC = 100%
Low Channel	CH37 = 2402 MHz
Mid Channel	CH17 = 2440 MHz
High Channel	CH39 = 2480 MHz

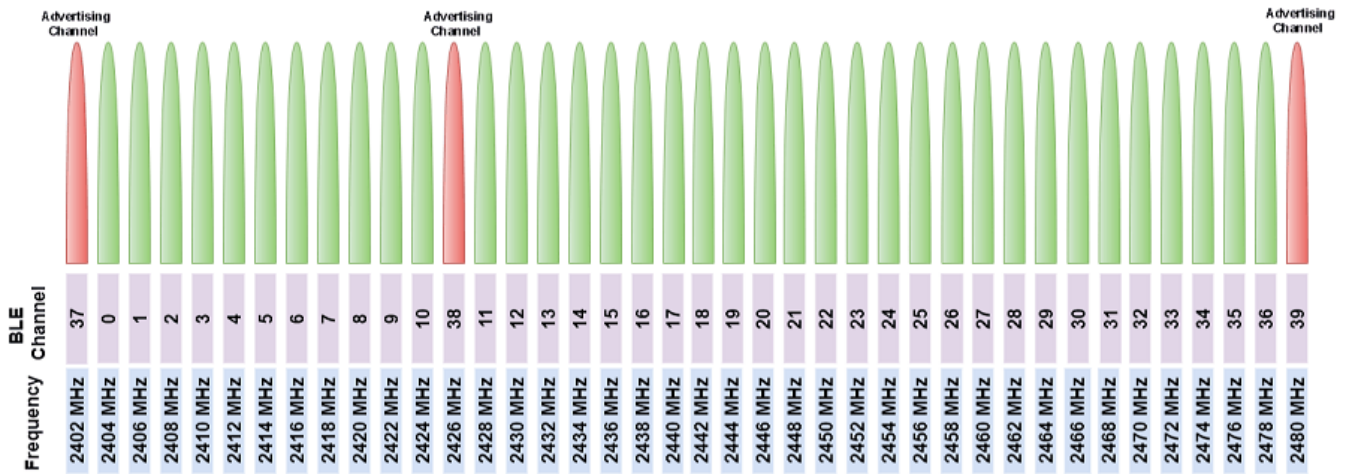

© <https://de.mathworks.com>

6 SUMMARY OF TEST RESULTS

Test specification

FCC 47 CFR Part 15
 RSS-247, Issue 3 (2023-08) / RSS-Gen, Issue 5 (2018-04)

Clause	Requirement / Test Case	Remark	Result	Verdict
§15.247(a)(2) RSS-247, 5.2 (a)	DTS bandwidth (6 dB)	KDB 558074, clause: 8.2	752.5 kHz	- PASS -
RSS Gen, 6.7	Occupied bandwidth (99%)	-/-	1080 kHz	- PASS -
§15.247(b)(3) RSS-247, 5.4 (d)	RF output power (conducted peak power)	KDB 558074, clause: 8.3.1	-0.1 dBm	- PASS -
§15.247(b)(4) RSS-247, 5.4 (d)	Antenna gain	-/-	0.4 dBi	- PASS -
§15.247(e) RSS-247, 5.2 (b)	Peak power spectral density (conducted peak PSD)	KDB 558074, clause: 8.4	-4.6 dBm/MHz	- PASS -
§15.247(d) RSS-247, 5.5	Band edge compliance (BEC), conducted	KDB 558074, clause: 8.5	< limit	- PASS -
§15.247(d) RSS-247, 5.5	Band edge compliance (BEC), radiated	KDB 558074, clause: 8.7	< limit	- PASS -
§15.247(d) RSS-247, 5.5	Conducted spurious emissions (CSE)	KDB 558074 DTS clause: 8.5	< limit	- PASS -
§15.247(d)/§15.209 RSS-247, 5.5	Radiated spurious emissions (RSE)	-/-	< limit	- PASS -
§15.207 RSS-Gen, 8.8	AC conducted emissions	EUT is battery powered	< limit	- N/A -

Comments and observations

Following pages show requirements and references of FCC Part 15.247, ANSI C63.10 and KDB 558074 only. Same tests are also applicable and valid for RSS-247, with clauses given in the table above.

7 TEST RESULTS

7.1 DTS Bandwidth (6 dB)

Applicability

This requirement applies to all types of DTS equipment.

Description

The DTS Bandwidth is defined as the 6 dB bandwidth.

Limit

§15.247

(a)(2) The minimum 6 dB bandwidth shall be at least 500 kHz.

Test procedure

ANSI C63.10, 11.8

The steps are as follows:

- a) Set RBW = 100 kHz.
- b) Set the VBW $\geq [3 \times \text{RBW}]$.
- c) Detector = peak.
- d) Trace mode = max hold.
- e) Sweep = auto couple.
- f) Allow the trace to stabilize.
- g) Measure the maximum width of the emission that is constrained by the frequencies associated with the two outermost amplitude points (upper and lower frequencies) that are attenuated by 6 dB relative to the maximum level measured in the fundamental emission.

The automatic bandwidth measurement capability of an instrument may be employed using the 6 dB bandwidth mode.

Test setup: 8.4

Test Results

EUT Mode	DTS Bandwidth (6 dB)			Limit [kHz]
	low channel [kHz]	mid channel [kHz]	high channel [kHz]	
Mode 1	752.5	752.5	752.5	≥ 500

Comment:

Plot 1: Mode 1, DTS Bandwidth, low channel

6 dB Bandwidth

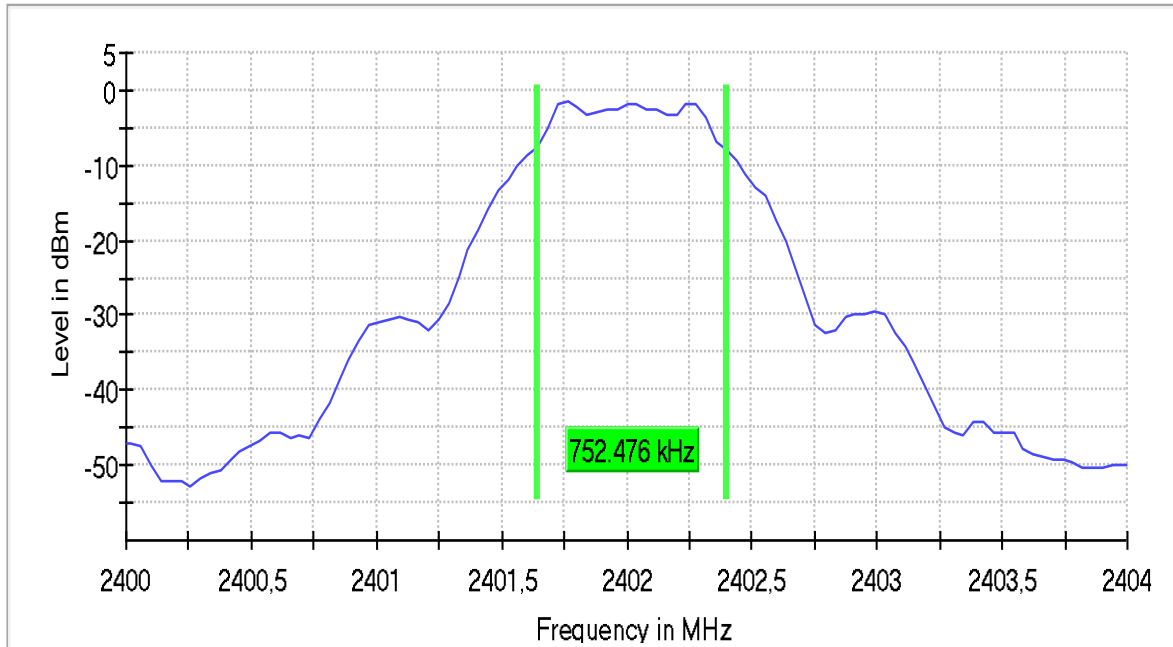

Plot 2: Mode 1, DTS Bandwidth, mid channel

6 dB Bandwidth

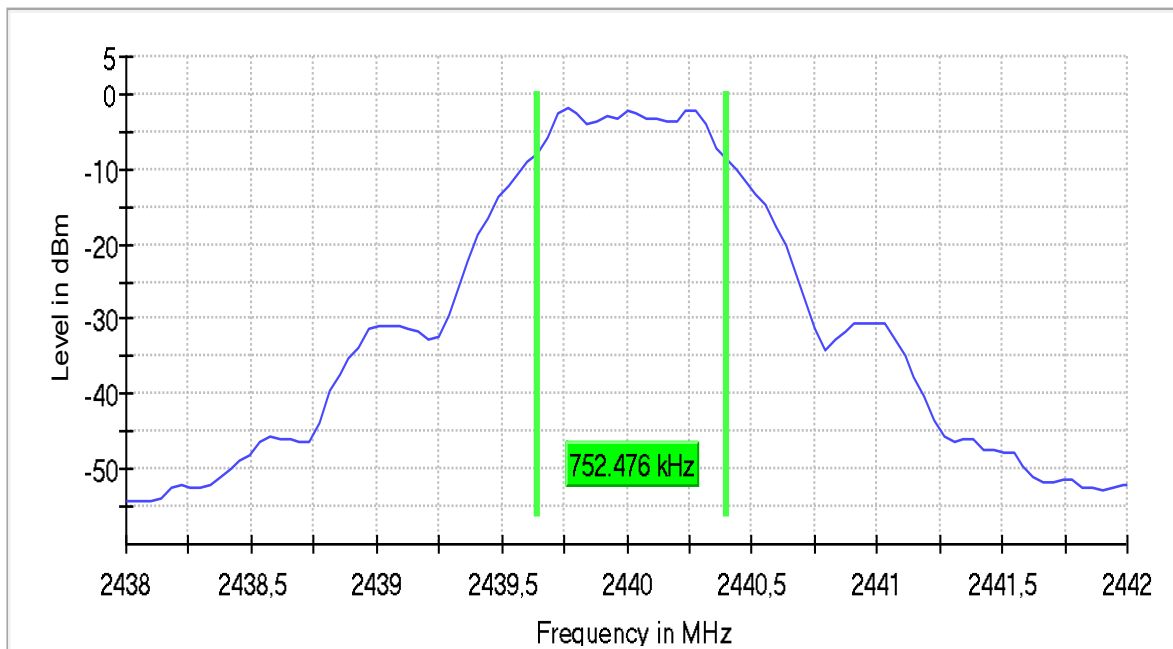

Plot 3: Mode 1, DTS Bandwidth, high channel

6 dB Bandwidth

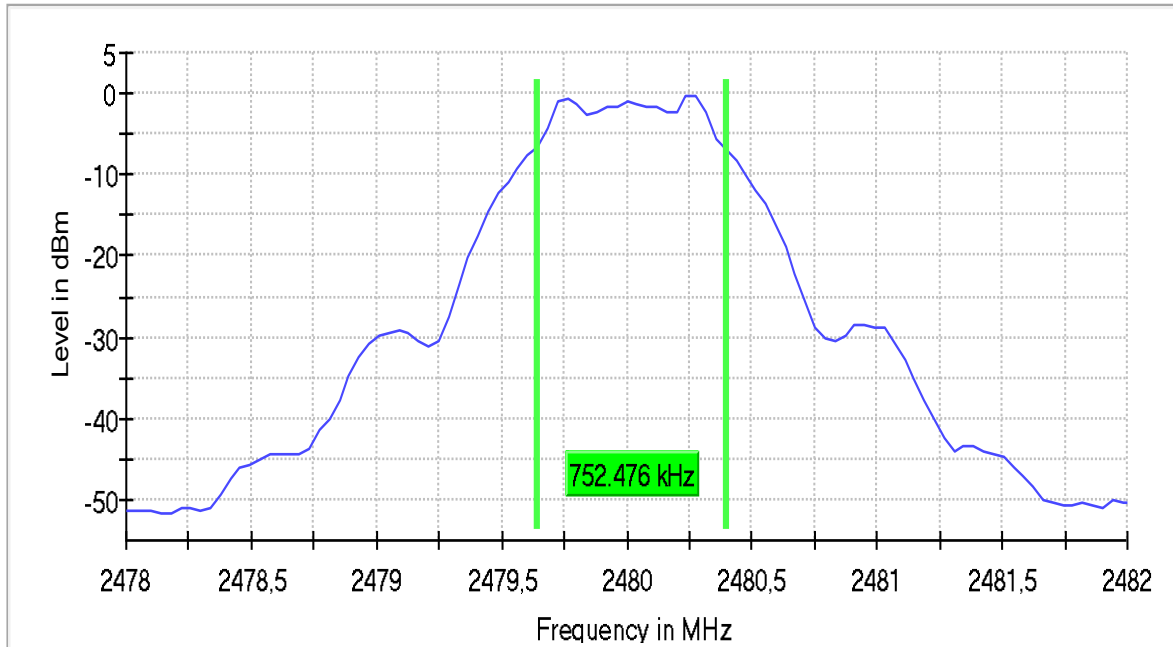

7.2 Occupied Bandwidth (99% OBW)

Applicability

This requirement applies to all types of DTS equipment.

Description

The Occupied Channel Bandwidth is the bandwidth that contains 99 % of the power of the signal (RSS-Gen).

Limit

No limit defined.

Test procedure

ANSI C63.10, 6.9.3

The occupied bandwidth is the frequency bandwidth such that, below its lower and above its upper frequency limits, the mean powers are each equal to 0.5% of the total mean power of the given emission.

The following procedure shall be used for measuring 99% power bandwidth:

- a) The instrument center frequency is set to the nominal EUT channel center frequency. The frequency span for the spectrum analyzer shall be between 1.5 times and 5.0 times the OBW.
- b) The nominal IF filter bandwidth (3 dB RBW) shall be in the range of 1% to 5% of the OBW, and VBW shall be approximately three times the RBW, unless otherwise specified by the applicable requirement.
- c) Set the reference level of the instrument as required, keeping the signal from exceeding the maximum input mixer level for linear operation. In general, the peak of the spectral envelope shall be more than $[10 \log(\text{OBW}/\text{RBW})]$ below the reference level. Specific guidance is given in 4.1.5.2.
- d) Step a) through step c) might require iteration to adjust within the specified range.
- e) Video averaging is not permitted. Where practical, a sample detection and single sweep mode shall be used. Otherwise, peak detection and max hold mode (until the trace stabilizes) shall be used.
- f) Use the 99% power bandwidth function of the instrument (if available) and report the measured bandwidth.
- g) If the instrument does not have a 99% power bandwidth function, then the trace data points are recovered and directly summed in linear power terms. The recovered amplitude data points, beginning at the lowest frequency, are placed in a running sum until 0.5% of the total is reached; that frequency is recorded as the lower frequency. The process is repeated until 99.5% of the total is reached; that frequency is recorded as the upper frequency. The 99% power bandwidth is the difference between these two frequencies.
- h) The occupied bandwidth shall be reported by providing plot(s) of the measuring instrument display; the plot axes and the scale units per division shall be clearly labeled. Tabular data may be reported in addition to the plot(s).

Note

Measurements with the peak detector are also suitable to demonstrate compliance of an EUT, as long as the required resolution bandwidth is used, because peak detection will yield amplitudes equal to or greater than amplitudes measured with RMS detector. The measurement data from a spectrum analyser peak detector will represent the worst-case results (see ANSI C63.10).

Test setup: 8.4

Test Results

EUT Mode	Occupied Bandwidth (99%)		
	low channel [kHz]	mid channel [kHz]	high channel [kHz]
Mode 1	1080	1080	1070

Comment:

Plot 4: Mode 1, 99% Occupied Bandwidth, low channel

99 % Bandwidth

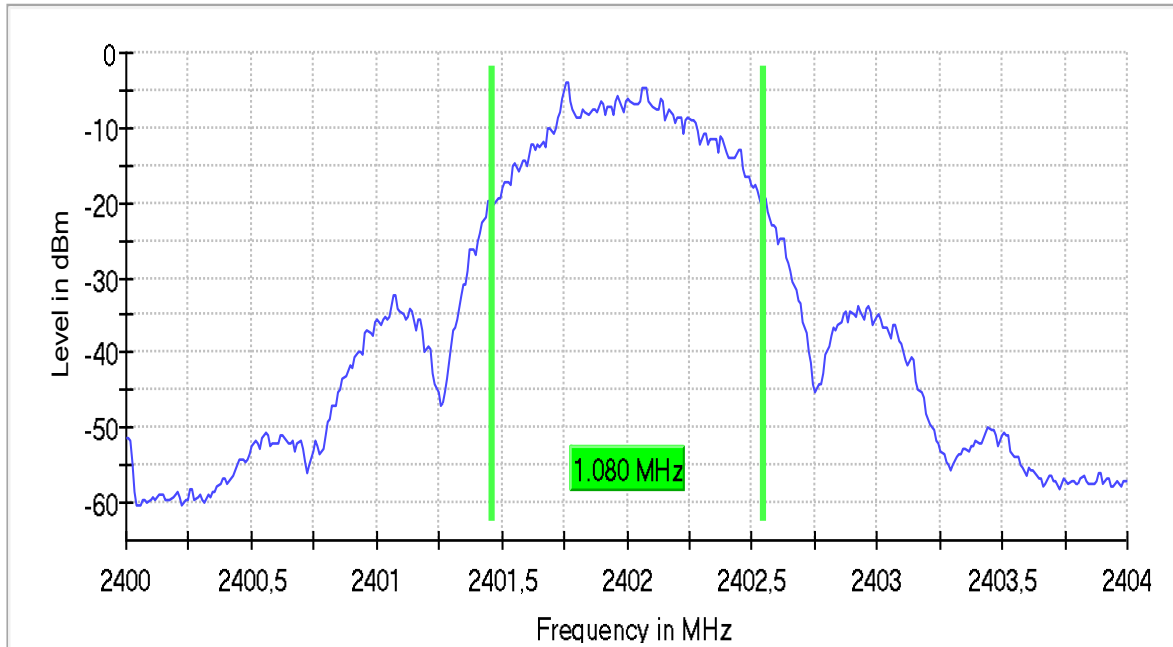

Plot 5: Mode 1, 99% Occupied Bandwidth, mid channel

99 % Bandwidth

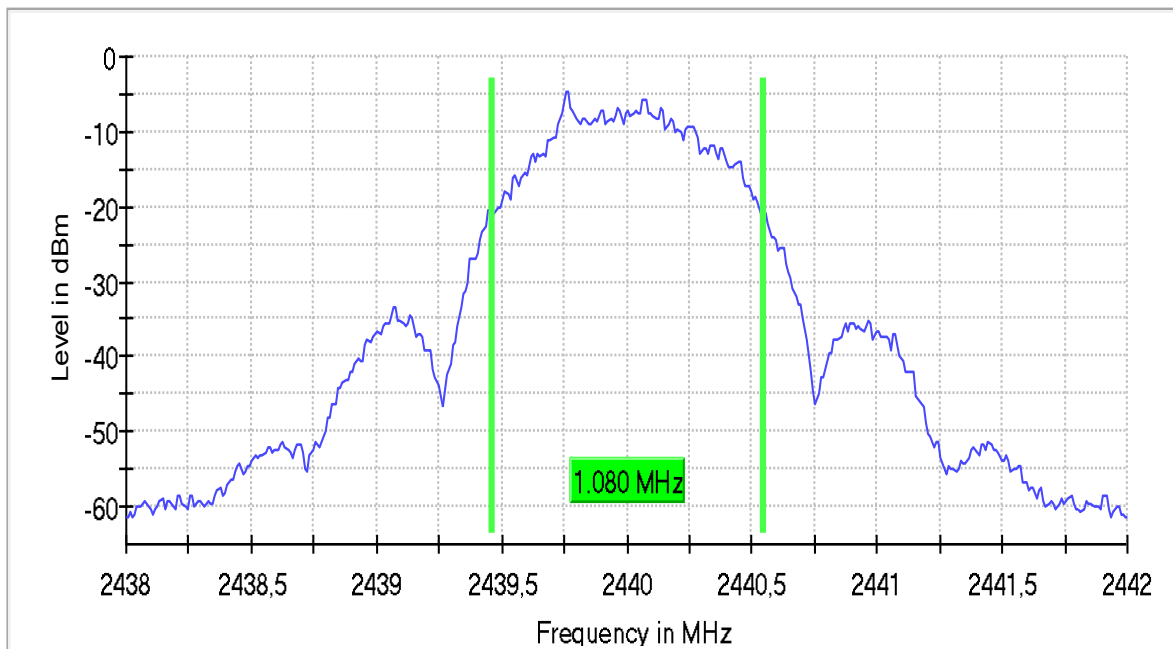

Plot 6: Mode 1, 99% Occupied Bandwidth, high channel

99 % Bandwidth

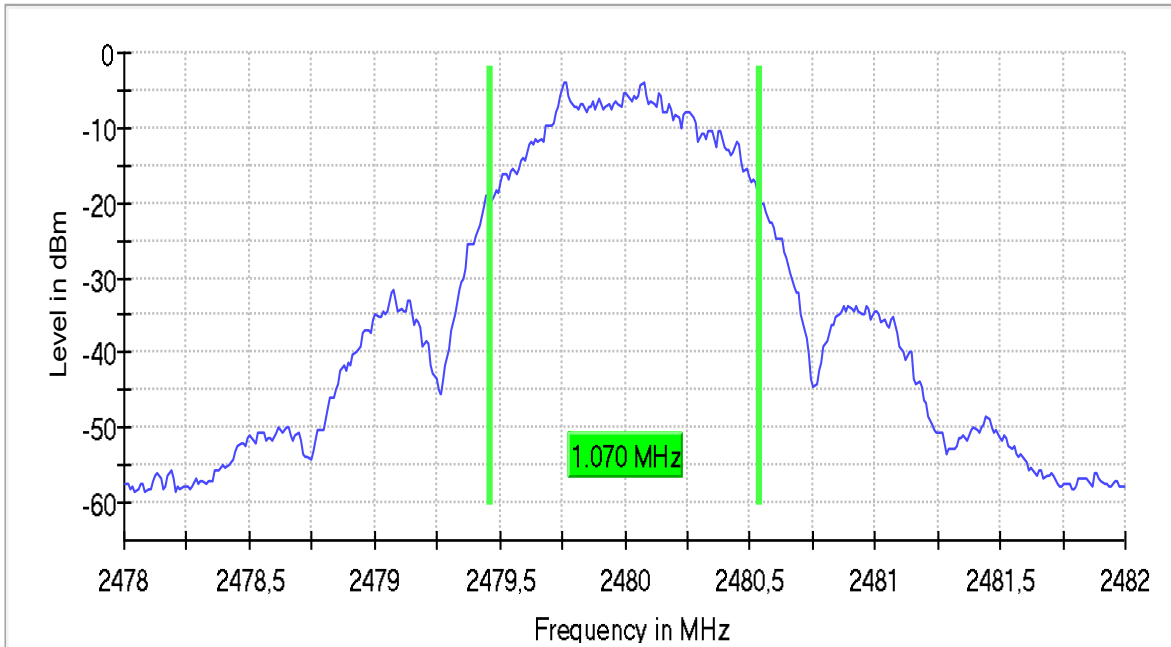

7.3 RF Output Power (Conducted Peak Power)

Applicability

This requirement applies to all types of DTS equipment.

Description

The RF Output Power is defined as the conducted peak output power.

Limit

§15.247

(b) The maximum peak conducted output power of the intentional radiator shall not exceed the following:

(3) For systems using digital modulation in the 902-928 MHz, 2400-2483.5 MHz, and 5725-5850 MHz bands: 1 Watt. As an alternative to a peak power measurement, compliance with the one Watt limit can be based on a measurement of the maximum conducted output power. Maximum Conducted Output Power is defined as the total transmit power delivered to all antennas and antenna elements averaged across all symbols in the signaling alphabet when the transmitter is operating at its maximum power control level. Power must be summed across all antennas and antenna elements. The average must not include any time intervals during which the transmitter is off or is transmitting at a reduced power level. If multiple modes of operation are possible (e.g., alternative modulation methods), the *maximum conducted output power* is the highest total transmit power occurring in any mode.

(4) The conducted output power limit specified in paragraph (b) of this section is based on the use of antennas with directional gains that do not exceed 6 dBi.

Test procedure

ANSI C63.10, 11.9.1.1

The following procedure shall be used when an instrument with a resolution bandwidth that is greater than the DTS bandwidth is available to perform the measurement:

- a) Set the RBW \geq DTS bandwidth.
- b) Set VBW \geq [3 \times RBW].
- c) Set span \geq [3 \times RBW].
- d) Sweep time = auto couple.
- e) Detector = peak.
- f) Trace mode = max hold.
- g) Allow trace to fully stabilize.
- h) Use peak marker function to determine the peak amplitude level.

Test setup: 8.4

Test Results

EUT Mode	RF Output Power (Conducted Peak Power)			Limit [dBm]
	low channel [dBm]	mid channel [dBm]	high channel [dBm]	
Mode 1	-0.9	-1.6	-0.1	30

Comment:

Plot 7: Mode 1, Peak Power, low channel

DUT Frequency (MHz)	Peak Power (dBm)	Limit Max (dBm)	Result
2402.000000	-0.9	30.0	PASS

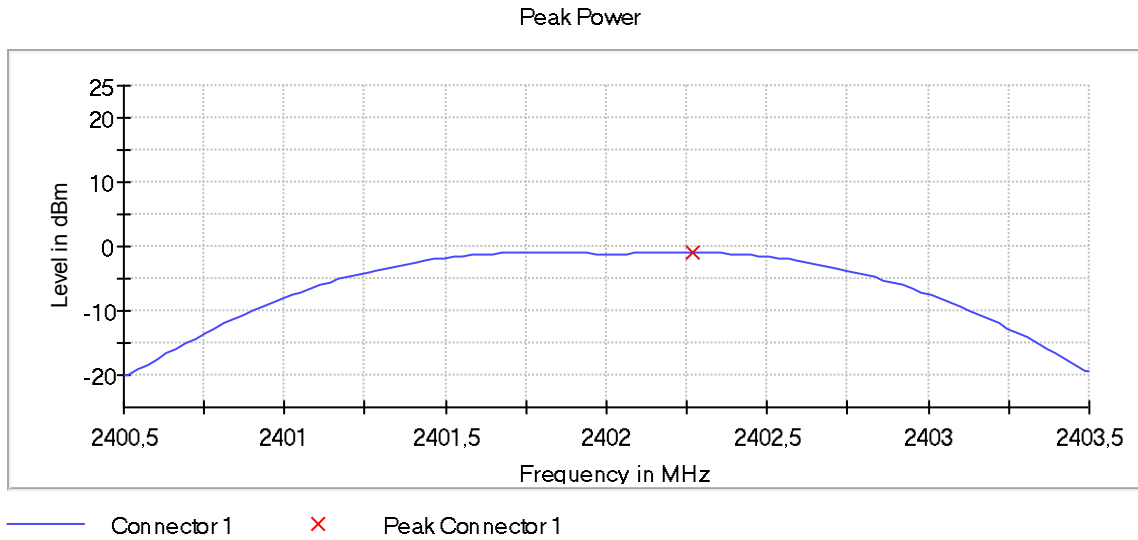

Plot 8: Mode 1, Peak Power, mid channel

DUT Frequency (MHz)	Peak Power (dBm)	Limit Max (dBm)	Result
2440.000000	-1.6	30.0	PASS

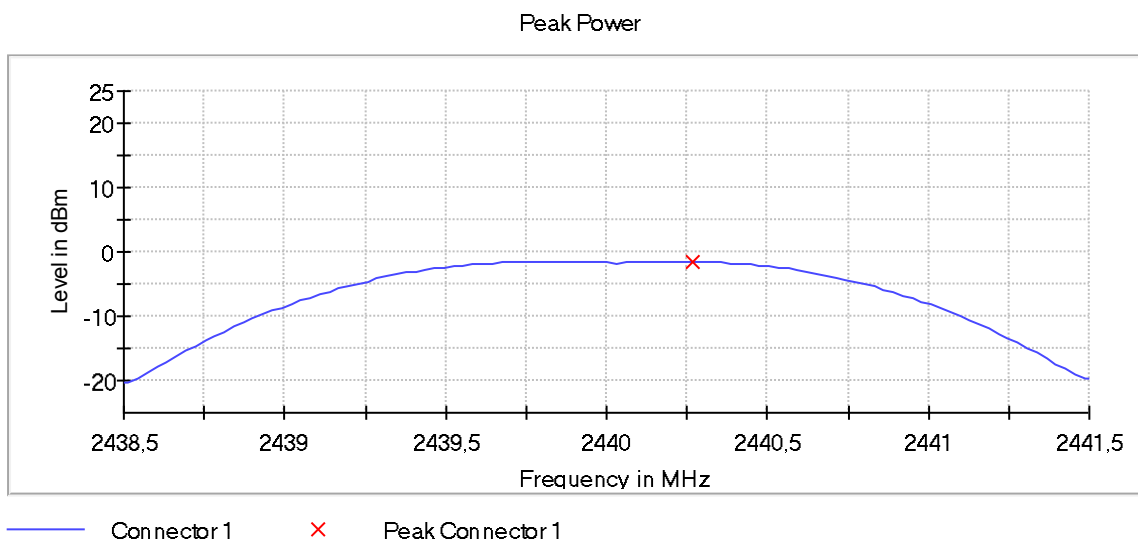

Plot 9: Mode 1, Peak Power, high channel

DUT Frequency (MHz)	Peak Power (dBm)	Limit Max (dBm)	Result
2480.000000	-0.1	30.0	PASS

Peak Power

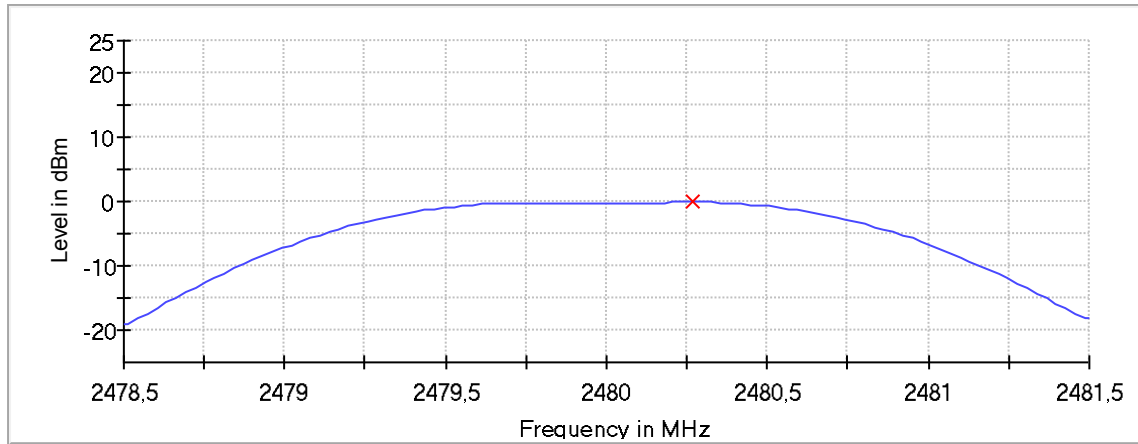

— Connector 1 × Peak Connector 1

7.4 Antenna Gain

Applicability

This requirement applies to all types of DTS equipment.

Description

The antenna gain is defined as the difference between radiated peak power (Peak EIRP) subtracted by the conducted peak power of the module, given in dBi.

Limit

§15.247

(b)(4) The conducted output power limit specified in paragraph (b) of this section is based on the use of antennas with directional gains that do not exceed 6 dBi.

Test Results

Antenna type	low channel [dBi]	mid channel [dBi]	high channel [dBi]	Limit [dBi]
Goal Post Antenna	0.4	0.4	0.4	6

Comment:

Antenna gain as declared by applicant.

7.5 Peak Power Spectral Density (PSD)

Applicability

This requirement applies to all types of DTS equipment.

Description

The Power Spectral Density (PSD) is defined as the conducted peak power spectral density in a 3 kHz bandwidth during any time of continuous transmission.

Limits

§15.247

(e) For digitally modulated systems, the power spectral density conducted from the intentional radiator to the antenna shall not be greater than 8 dBm in any 3 kHz band during any time interval of continuous transmission. This power spectral density shall be determined in accordance with the provisions of paragraph (b) of this section. The same method of determining the conducted output power shall be used to determine the power spectral density.

Test procedure

ANSI C63.10, 11.10.2

The following procedure shall be used if maximum peak conducted output power was used to determine compliance, and it is optional if the maximum conducted (average) output power was used to determine compliance:

- a) Set analyzer center frequency to DTS channel center frequency.
- b) Set the span to 1.5 times the DTS bandwidth.
- c) Set the RBW to $3 \text{ kHz} \leq \text{RBW} \leq 100 \text{ kHz}$.
- d) Set the VBW $\geq [3 \times \text{RBW}]$.
- e) Detector = peak.
- f) Sweep time = auto couple.
- g) Trace mode = max hold.
- h) Allow trace to fully stabilize.
- i) Use the peak marker function to determine the maximum amplitude level within the RBW.
- j) If measured value exceeds requirement, then reduce RBW (but no less than 3 kHz) and repeat.

Test setup: 8.4

Test Results

EUT Mode	Peak Power Spectral Density [dBm / 3 kHz]			Limit [dBm / 3 kHz]
	low channel	mid channel	high channel	
Mode 1	-5.8	-5.9	-4.6	8

Comment:

Plot 10: Mode 1, Peak PSD, low channel

DUT Frequency (MHz)	Frequency (MHz)	PSD (dBm)	Limit Max (dBm)	Result
2402.000000	2402.067423	-5.817	8.0	PASS

Peak Power Spectral Density

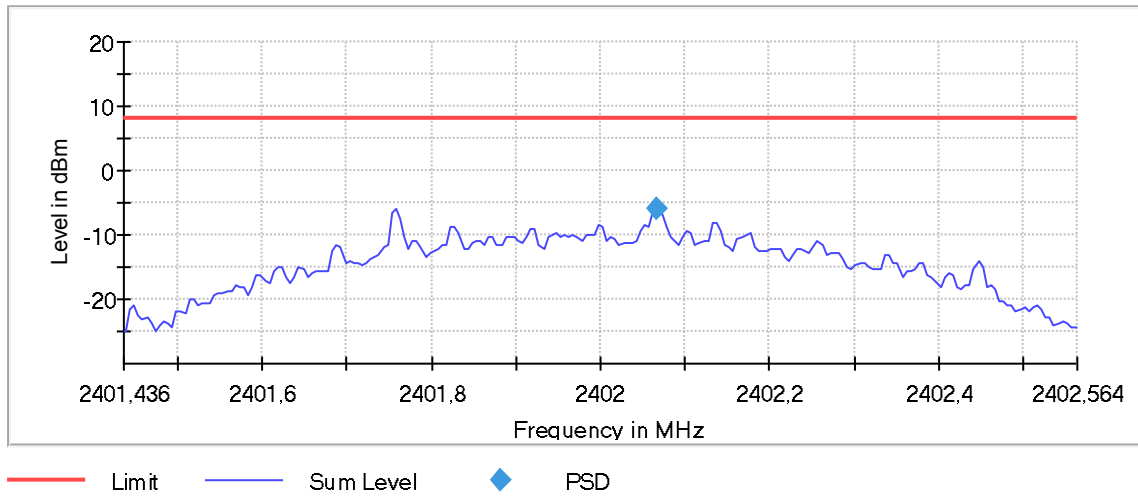

Plot 11: Mode 1, Peak PSD, mid channel

DUT Frequency (MHz)	Frequency (MHz)	PSD (dBm)	Limit Max (dBm)	Result
2440.000000	2439.757776	-5.915	8.0	PASS

Peak Power Spectral Density

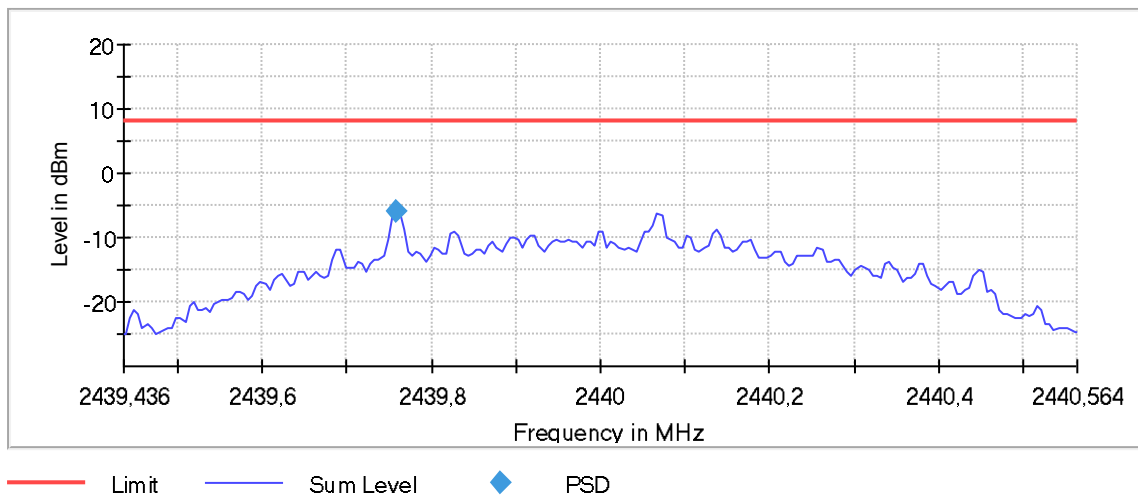

Plot 12: Mode 1, Peak PSD, high channel

DUT Frequency (MHz)	Frequency (MHz)	PSD (dBm)	Limit Max (dBm)	Result
2480.000000	2479.757776	-4.568	8.0	PASS

Peak Power Spectral Density

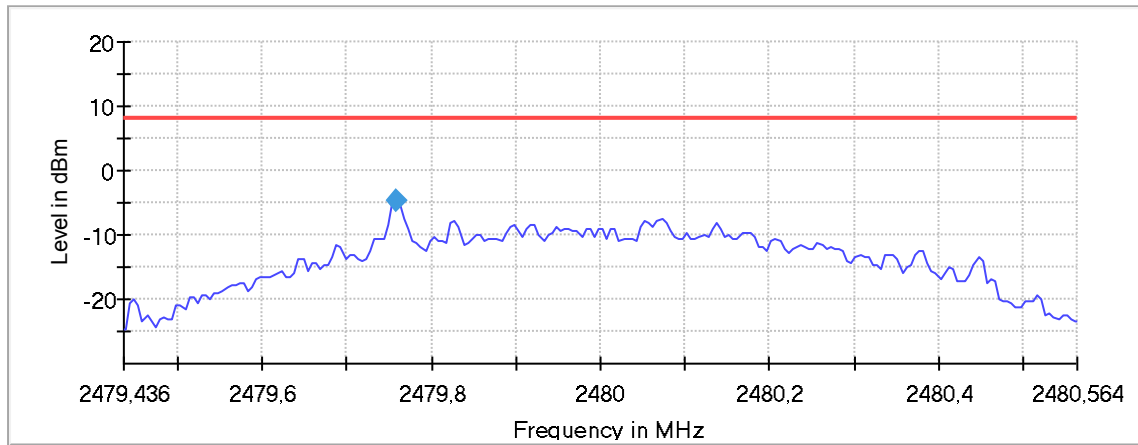

— Limit — Sum Level ◆ PSD

7.6 Band Edge Compliance (BEC), conducted

Applicability

This requirement applies to all types of DTS equipment.

Description

Emissions within a restricted band and within 2 MHz of an authorized band edge may be measured using either the marker-delta method (ANSI C63.10, 6.10.6) or the integration method (ANSI C63.20, 11.13.3), provided that the DTS bandwidth (or EBW) edge falls within 2 MHz of the band edge. Otherwise, all unwanted emissions measurements shall be performed using the standard methods.

Limits

§15.247

(d) In any 100 kHz bandwidth outside the frequency band in which the spread spectrum or digitally modulated intentional radiator is operating, the radio frequency power that is produced by the intentional radiator shall be at least 20 dB below that in the 100 kHz bandwidth within the band that contains the highest level of the desired power, based on either an RF conducted or a radiated measurement, provided the transmitter demonstrates compliance with the peak conducted power limits. Attenuation below the general limits specified in §15.209(a) is not required.

Test procedure

ANSI C63.10, 11.11

Reference level measurement:

Establish a reference level by using the following procedure:

- a) Set instrument center frequency to DTS channel center frequency.
 - b) Set the span to ≥ 1.5 times the DTS bandwidth.
 - c) Set the RBW = 100 kHz.
 - d) Set the VBW $\geq [3 \times \text{RBW}]$.
 - e) Detector = peak.
 - f) Sweep time = auto couple.
 - g) Trace mode = max hold.
 - h) Allow trace to fully stabilize.
 - i) Use the peak marker function to determine the maximum PSD level.
- Note that the channel found to contain the maximum PSD level can be used to establish the reference level.

Emission level measurement:

Establish an emission level by using the following procedure:

- a) Set the center frequency and span to encompass frequency range to be measured.
- b) Set the RBW = 100 kHz.
- c) Set the VBW $\geq [3 \times \text{RBW}]$.
- d) Detector = peak.
- e) Sweep time = auto couple.
- f) Trace mode = max hold.
- g) Allow trace to fully stabilize.
- h) Use the peak marker function to determine the maximum amplitude level.

Ensure that the amplitude of all unwanted emissions outside of the authorized frequency band (excluding restricted frequency bands) is attenuated by at least the minimum requirements as specified (≥ 20 dBc).

The marker-delta method, as described in ANSI C63.10, 6.10.6 can be used to perform measurements of the radiated unwanted emissions level at the band-edges provided that the 99 % OBW of the fundamental emission is within 2 MHz of the authorized band edge.

Test setup: 8.4

TR No.: 24050180-41266-1

2024-11-04

Test results			
BEC	low channel [dBc]	high channel [dBc]	Limit [dBc]
Mode 1	<i>(see plots)</i>	<i>(see plots)</i>	≥ 20
Comment:	---		

Plot 13: Mode 1, BEC, low channel

Measurements

Frequency (MHz)	Level (dBm)	Margin (dB)	Limit (dBm)	Result
2399.975000	-46.7	25.8	-20.9	PASS
2399.925000	-48.4	27.5	-20.9	PASS
2399.875000	-50.7	29.8	-20.9	PASS
2399.825000	-53.6	32.7	-20.9	PASS
2399.525000	-53.6	32.7	-20.9	PASS
2399.575000	-53.8	32.9	-20.9	PASS
2399.775000	-53.9	33.0	-20.9	PASS
2399.725000	-54.2	33.4	-20.9	PASS
2399.675000	-54.8	33.9	-20.9	PASS
2399.625000	-54.8	34.0	-20.9	PASS
2399.475000	-55.2	34.3	-20.9	PASS
2399.025000	-55.6	34.7	-20.9	PASS
2399.425000	-56.0	35.1	-20.9	PASS
2399.375000	-56.0	35.1	-20.9	PASS
2398.975000	-56.1	35.2	-20.9	PASS

Band Edge

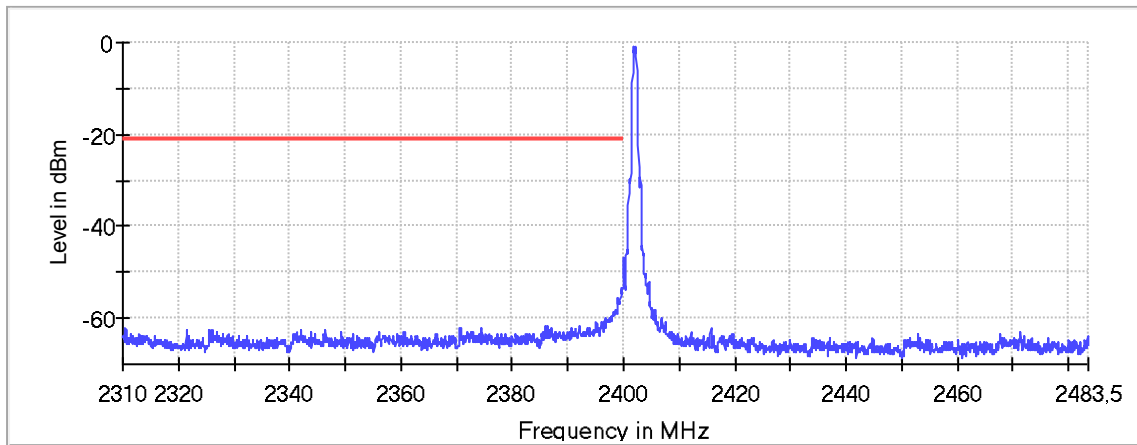

— Limit — Sum Level × Fail

Plot 14: Mode 1, BEC, high channel

Measurements

Frequency (MHz)	Level (dBm)	Margin (dB)	Limit (dBm)	Result
2483.525000	-56.1	36.6	-19.6	PASS
2483.575000	-56.8	37.2	-19.6	PASS
2483.875000	-57.3	37.7	-19.6	PASS
2483.625000	-57.4	37.8	-19.6	PASS
2484.375000	-57.5	37.9	-19.6	PASS
2484.325000	-57.6	38.0	-19.6	PASS
2483.825000	-57.6	38.0	-19.6	PASS
2484.025000	-57.6	38.0	-19.6	PASS
2483.975000	-57.6	38.1	-19.6	PASS
2483.925000	-57.8	38.2	-19.6	PASS
2483.775000	-57.9	38.4	-19.6	PASS
2483.725000	-58.2	38.6	-19.6	PASS
2483.675000	-58.2	38.6	-19.6	PASS
2484.125000	-58.4	38.8	-19.6	PASS
2484.275000	-58.6	39.0	-19.6	PASS

Band Edge

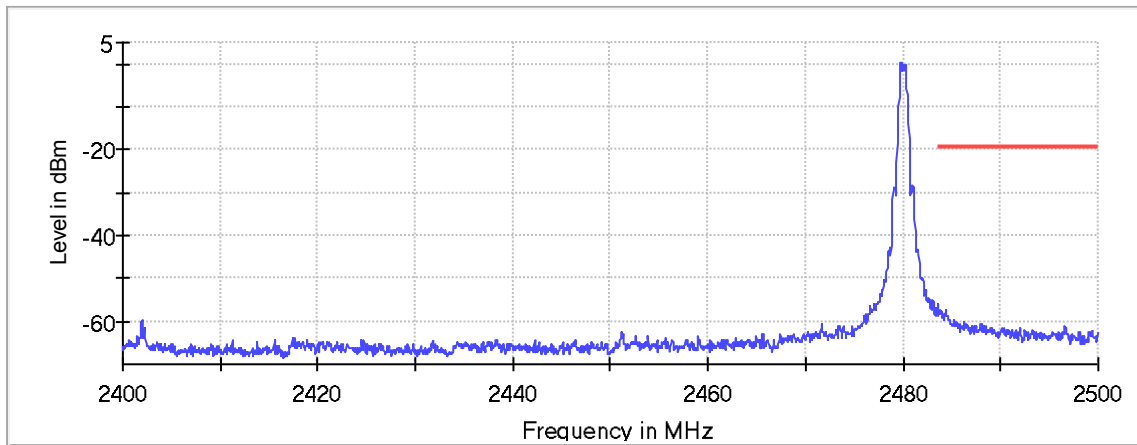

— Limit — Sum Level × Fail

7.7 Band Edge Compliance (BEC), radiated

Applicability

This requirement applies to all types of DTS equipment.

Description

Emissions within a restricted band and within 2 MHz of an authorized band edge may be measured using either the marker-delta method (ANSI C63.10, 6.10.6) or the integration method (ANSI C63.20, 11.13.3), provided that the DTS bandwidth (or EBW) edge falls within 2 MHz of the band edge. Otherwise, all unwanted emissions measurements shall be performed using the standard methods.

Limits

§15.247

(d) In any 100 kHz bandwidth outside the frequency band in which the spread spectrum or digitally modulated intentional radiator is operating, the radio frequency power that is produced by the intentional radiator shall be at least 20 dB below that in the 100 kHz bandwidth within the band that contains the highest level of the desired power, based on either an RF conducted or a radiated measurement, provided the transmitter demonstrates compliance with the peak conducted power limits. If the transmitter complies with the conducted power limits based on the use of RMS averaging over a time interval, as permitted under paragraph (b)(3) of this section, the attenuation required under this paragraph shall be 30 dB instead of 20 dB. Attenuation below the general limits specified in §15.209(a) is not required. In addition, radiated emissions which fall in the restricted bands, as defined in §15.205(a), must also comply with the radiated emission limits specified in §15.209(a) (see §15.205(c)).

Test procedure

The marker-delta method as described in ANSI C63.10, 6.10.6 or the integration method as described in ANSI C63.10, 11.13.3 can be used to perform measurements of the unwanted emissions level at the band edges.

Test setup: 8.2

Test results

BEC	low channel [dµV/m @ 3m]	high channel [dµV/m @ 3m]	Limit [dµV/m @ 3m]
Mode 1	(see plots)	(see plots)	≤ 54 AVG / ≤ 74 PK

Comment:

Plot 15: Mode 1, BEC, low channel

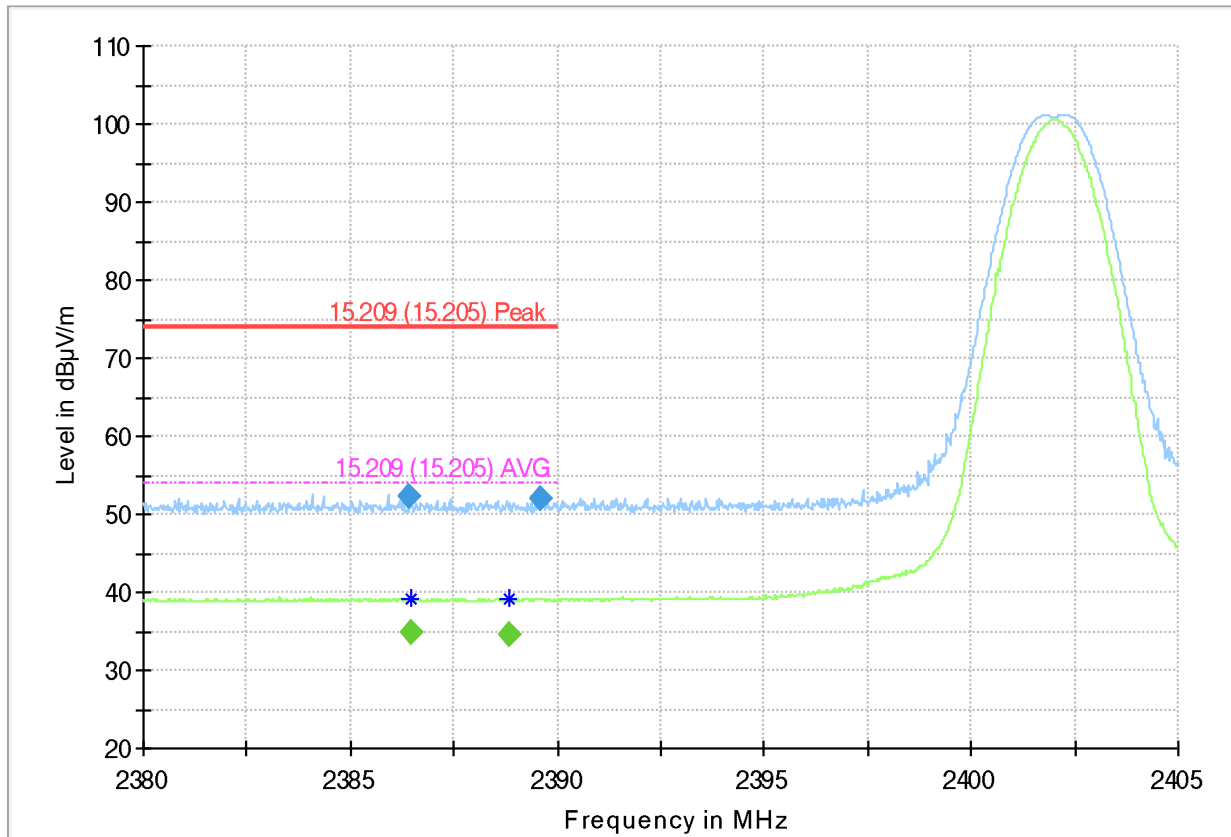

- Preview Result 2-AVG
- Preview Result 1-PK+
- 15.209 (15.205) Peak
- - - 15.209 (15.205) AVG
- * Critical_Freqs AVG
- ◆ Final_Result PK+
- ◆ Final_Result AVG

Final Result

Frequency (MHz)	MaxPeak (dBµV/m)	Average (dBµV/m)	Limit (dBµV/m)	Margin (dB)	Meas. Time (ms)	Bandwidth (kHz)	Height (cm)	PoI
2386.400000	52.26	---	74.00	21.74	10000.0	1000.000	150.0	V
2386.450000	---	34.85	54.00	19.15	10000.0	1000.000	150.0	H
2388.825000	---	34.64	54.00	19.36	10000.0	1000.000	150.0	V
2389.600000	52.05	---	74.00	21.95	10000.0	1000.000	150.0	H

Plot 16: Mode 1, BEC, high channel

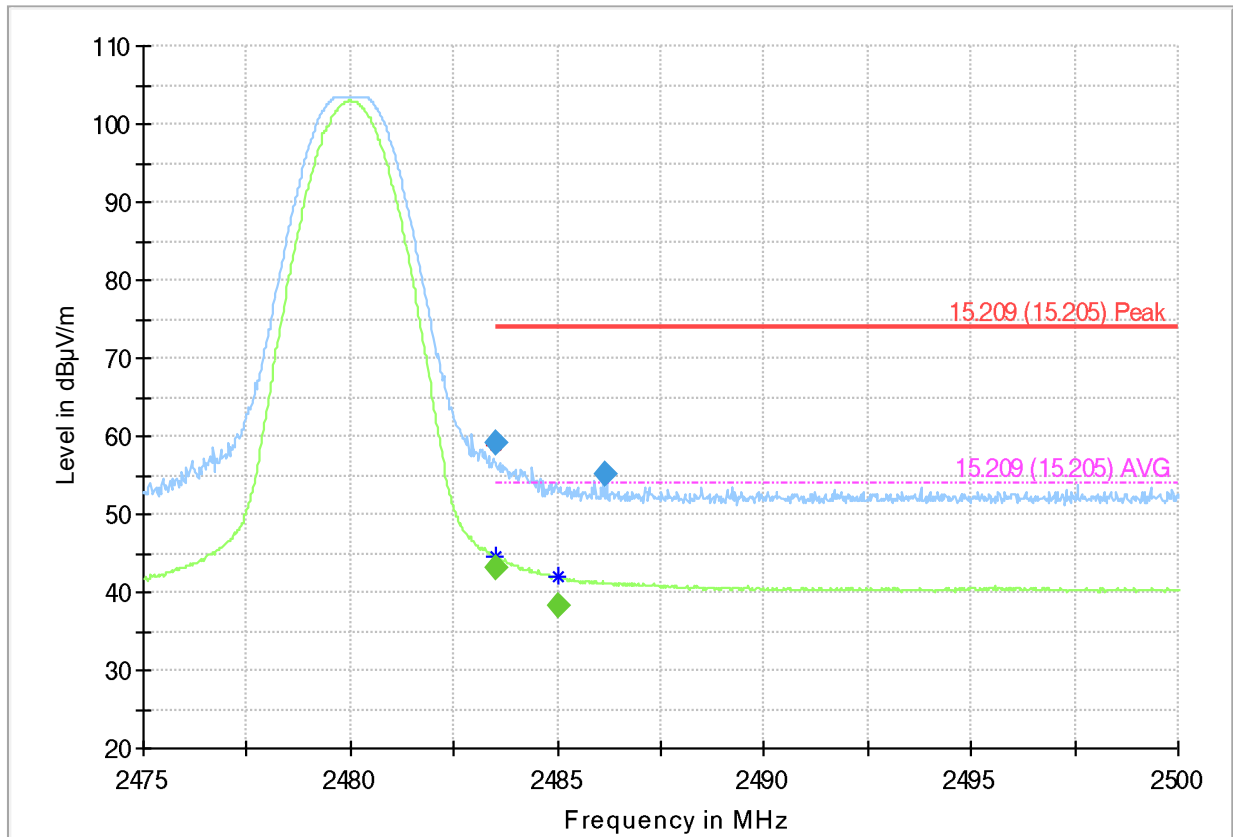

- Preview Result 2-AVG
- Preview Result 1-PK+
- 15.209 (15.205) Peak
- - - 15.209 (15.205) AVG
- * Critical_Freqs PK+
- ◆ Final_Result PK+
- ◆ Final_Result AVG
- * Critical_Freqs AVG

Final Result

Frequency (MHz)	MaxPeak (dBµV/m)	Average (dBµV/m)	Limit (dBµV/m)	Margin (dB)	Meas. Time (ms)	Bandwidth (kHz)	Height (cm)	Poi
2483.500000	---	43.02	54.00	10.98	10000.0	1000.000	150.0	V
2483.500000	59.26	---	74.00	14.74	10000.0	1000.000	150.0	H
2485.025000	---	38.32	54.00	15.68	10000.0	1000.000	150.0	V
2486.150000	55.01	---	74.00	18.99	10000.0	1000.000	150.0	H

7.8 Conducted Spurious Emissions (CSE)

Applicability

This requirement applies to all types of DTS equipment.

Description

Spurious emission / unwanted emissions are emission on a frequency or frequencies which are outside the authorized band and the level of which may be reduced without affecting the corresponding transmission of information. Spurious emissions include harmonic emissions, parasitic emissions, intermodulation products and frequency conversion products.

Limits

§15.247

(d) In any 100 kHz bandwidth outside the frequency band in which the spread spectrum or digitally modulated intentional radiator is operating, the radio frequency power that is produced by the intentional radiator shall be at least 20 dB below that in the 100 kHz bandwidth within the band that contains the highest level of the desired power, based on either an RF conducted or a radiated measurement, provided the transmitter demonstrates compliance with the peak conducted power limits. Attenuation below the general limits specified in §15.209(a) is not required.

Test procedure

ANSI C63.10, 11.11

Reference level measurement:

Establish a reference level by using the following procedure:

- a) Set instrument center frequency to DTS channel center frequency.
 - b) Set the span to ≥ 1.5 times the DTS bandwidth.
 - c) Set the RBW = 100 kHz.
 - d) Set the VBW $\geq [3 \times \text{RBW}]$.
 - e) Detector = peak.
 - f) Sweep time = auto couple.
 - g) Trace mode = max hold.
 - h) Allow trace to fully stabilize.
 - i) Use the peak marker function to determine the maximum PSD level.
- Note that the channel found to contain the maximum PSD level can be used to establish the reference level.

Emission level measurement:

Establish an emission level by using the following procedure:

- a) Set the center frequency and span to encompass frequency range to be measured.
- b) Set the RBW = 100 kHz.
- c) Set the VBW $\geq [3 \times \text{RBW}]$.
- d) Detector = peak.
- e) Sweep time = auto couple.
- f) Trace mode = max hold.
- g) Allow trace to fully stabilize.
- h) Use the peak marker function to determine the maximum amplitude level.

Ensure that the amplitude of all unwanted emissions outside of the authorized frequency band (excluding restricted frequency bands) is attenuated by at least the minimum requirements as specified (≥ 20 dBc).

The marker-delta method, as described in ANSI C63.10, 6.10.6 can be used to perform measurements of the radiated unwanted emissions level at the band-edges provided that the 99 % OBW of the fundamental emission is within 2 MHz of the authorized band edge.

Test setup: 8.4

Test results					
EUT Mode / Channel	Frequency [MHz]	Peak/RMS Detector	Level [dBm]	Limit [dBm]	Verdict
Mode 1 / low	<i>(see plots)</i>	<i>(see plots)</i>	<i>(see plots)</i>	<i>(see plots)</i>	- passed -
Mode 1 / mid	<i>(see plots)</i>	<i>(see plots)</i>	<i>(see plots)</i>	<i>(see plots)</i>	- passed -
Mode 1 / high	<i>(see plots)</i>	<i>(see plots)</i>	<i>(see plots)</i>	<i>(see plots)</i>	- passed -

* all detected peaks are more than 6 dB below the limit

Comment:	---
-----------------	-----

Plot 17: Mode 1, CSE, low channel

Frequency (MHz)	Level (dBm)	Margin (dB)	Limit (dBm)
4807.166065	-29.9	8.1	-21.8
7205.789099	-47.7	26.0	-21.8
2395.021008	-48.7	27.0	-21.8
9604.412133	-52.8	31.1	-21.8
9614.406396	-66.1	44.4	-21.8
12013.029431	-68.6	46.9	-21.8
2385.063025	-69.9	48.1	-21.8
25835.094666	-69.9	48.1	-21.8
25145.490544	-70.3	48.6	-21.8
25905.054505	-70.4	48.6	-21.8
25965.020081	-70.4	48.6	-21.8
14411.652465	-70.4	48.7	-21.8
25185.467595	-70.5	48.7	-21.8
25335.381534	-70.5	48.7	-21.8
17709.759137	-70.8	49.0	-21.8

Spurious

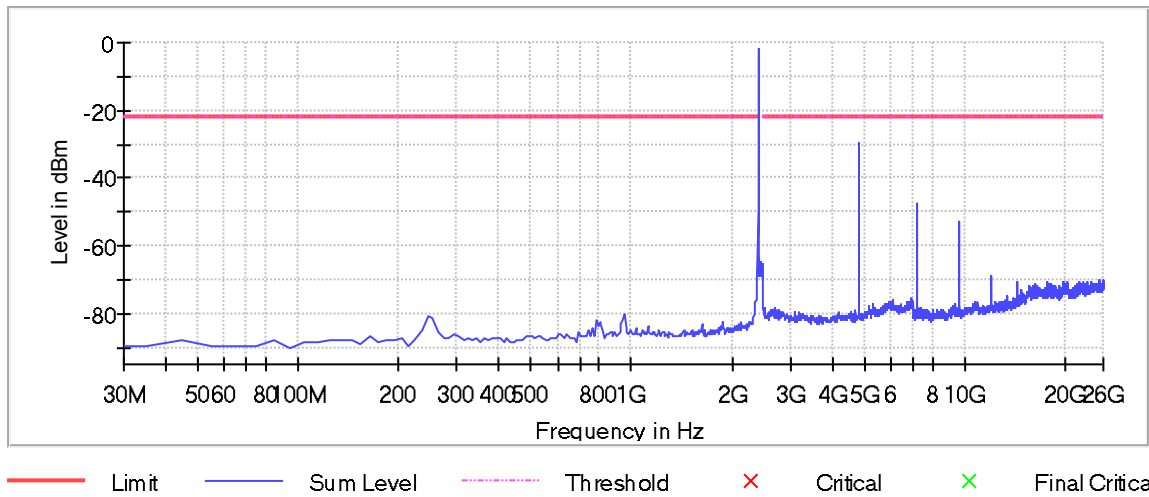

Plot 18: Mode 1, CSE, mid channel

Frequency (MHz)	Level (dBm)	Margin (dB)	Limit (dBm)
4877.125903	-29.5	7.1	-22.4
7315.725988	-44.0	21.6	-22.4
7325.720251	-49.5	27.1	-22.4
9754.326073	-52.8	30.4	-22.4
9764.320336	-53.6	31.2	-22.4
1956.869748	-62.2	39.8	-22.4
20398.215788	-69.1	46.7	-22.4
20368.233000	-70.1	47.8	-22.4
12202.920421	-70.2	47.8	-22.4
20378.227263	-70.2	47.8	-22.4
14641.520506	-70.4	48.0	-22.4
25175.473332	-70.4	48.0	-22.4
24735.725776	-70.6	48.2	-22.4
23846.236400	-70.6	48.2	-22.4
22586.959307	-70.6	48.2	-22.4

Spurious

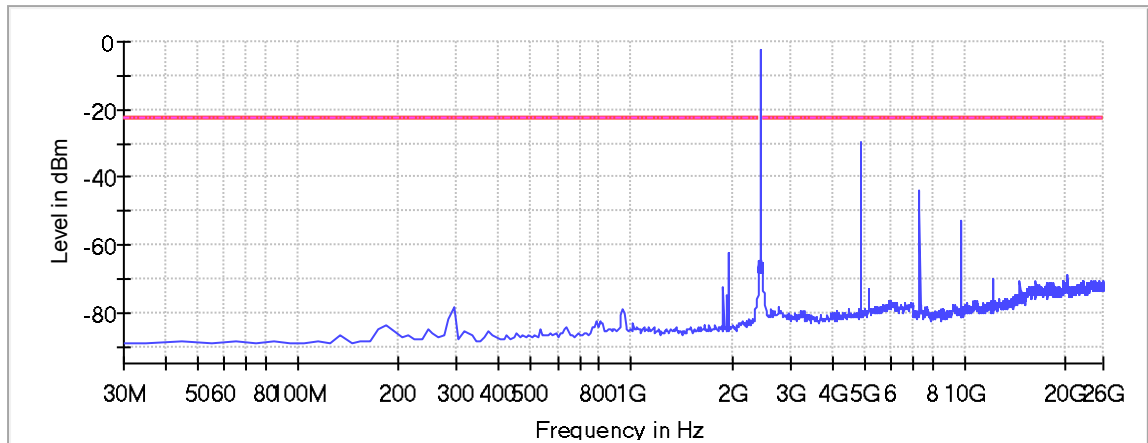

— Limit — Sum Level - - - - Threshold × Critical × Final Critical

Plot 19: Mode 1, CSE, high channel

Frequency (MHz)	Level (dBm)	Margin (dB)	Limit (dBm)
4957.080004	-33.2	11.8	-21.5
7435.657140	-45.3	23.8	-21.5
7445.651402	-45.7	24.2	-21.5
9924.228538	-54.9	33.4	-21.5
9914.234275	-55.1	33.6	-21.5
2488.497131	-59.8	38.3	-21.5
2498.491394	-67.5	46.0	-21.5
14881.382809	-69.1	47.6	-21.5
24965.593816	-69.6	48.1	-21.5
17699.764875	-70.2	48.7	-21.5
19718.605929	-70.4	48.9	-21.5
20388.221526	-70.4	48.9	-21.5
18029.575542	-70.4	48.9	-21.5
25935.037293	-70.4	48.9	-21.5
25575.243838	-70.5	49.0	-21.5

Spurious

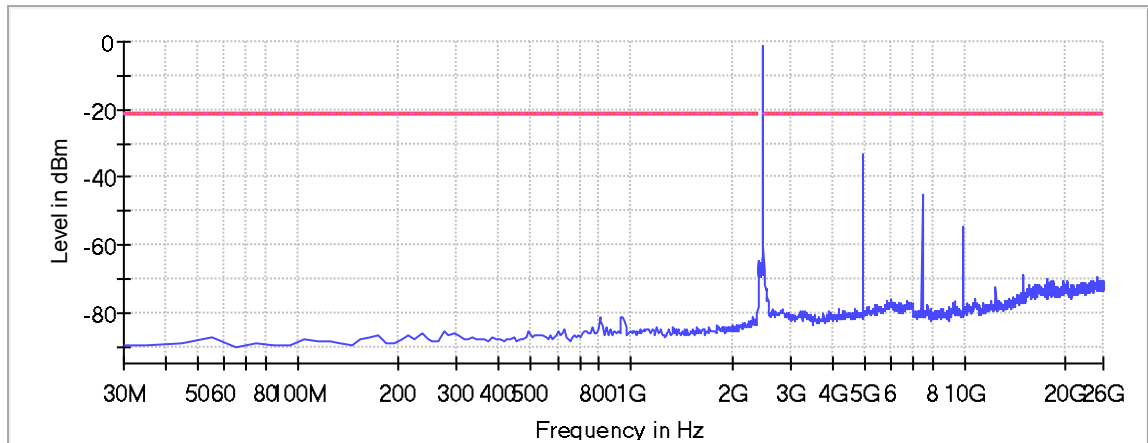

— Limit — Sum Level - - - - Threshold × Critical × Final Critical

7.9 Radiated Spurious Emissions (RSE)

Applicability

This requirement applies to all types of DTS equipment.

Description

Spurious emission / unwanted emissions are emission on a frequency or frequencies which are outside the authorized band and the level of which may be reduced without affecting the corresponding transmission of information. Spurious emissions include harmonic emissions, parasitic emissions, intermodulation products and frequency conversion products. Measurements shall be made to detect spurious emissions that may be radiated directly from the cabinet, control circuits, power leads, or intermediate circuit elements under normal conditions of installation and operation.

Limits

In any 100 kHz bandwidth outside the frequency band in which the spread spectrum or digitally modulated intentional radiator is operating, the radio frequency power that is produced by the intentional radiator shall be at least 20 dB below that in the 100 kHz bandwidth within the band that contains the highest level of the desired power, based on either an RF conducted or a radiated measurement. Attenuation below the general limits specified in Section 15.209(a) is not required. In addition, radiated emissions which fall in the restricted bands, as defined in §15.205(a), must also comply with the radiated emission limits specified in §15.209(a) (see §15.205(c)).

Frequency [MHz]	Field Strength [$\mu\text{V/m}$] / [$\text{dB}\mu\text{V/m}$]	Measurement distance [m]
0.009 – 0.490	2400/F[kHz]	300
0.490 – 1.705	24000/F[kHz]	30
1.705 – 30.0	30.0 / 29.5	30
30 – 88	100 / 40.0	3
88 – 216	150 / 43.5	3
216 – 960	200 / 46.0	3
960 – 40 000	500 / 54.0	3

Note

Radiated Spurious Emissions (RSE) are performed for low / mid / high channel and modulation with the highest output power (worst case). In case of spurious other modulations are spot-checked.

Test setup: 8.1, 8.2, 8.3

Test results

EUT Mode / Channel	Frequency [MHz]	Detector	Level [$\text{dB}\mu\text{V/m}$ @LD]	Limit [$\text{dB}\mu\text{V/m}$ @LD]	Verdict
Mode 1 / low	(see plots)	(see plots)	(see plots)	(see plots)	- passed -
Mode 1 / mid	(see plots)	(see plots)	(see plots)	(see plots)	- passed -
Mode 1 / high	(see plots)	(see plots)	(see plots)	(see plots)	- passed -

* all detected peaks are more than 6 dB below the limit

Note:

LD = Limit Distance of 300m / 30m / 3m depending on frequency range, see limit table

Plot 20: Mode 1, RSE 9 kHz – 30 MHz, low channel, loop antenna

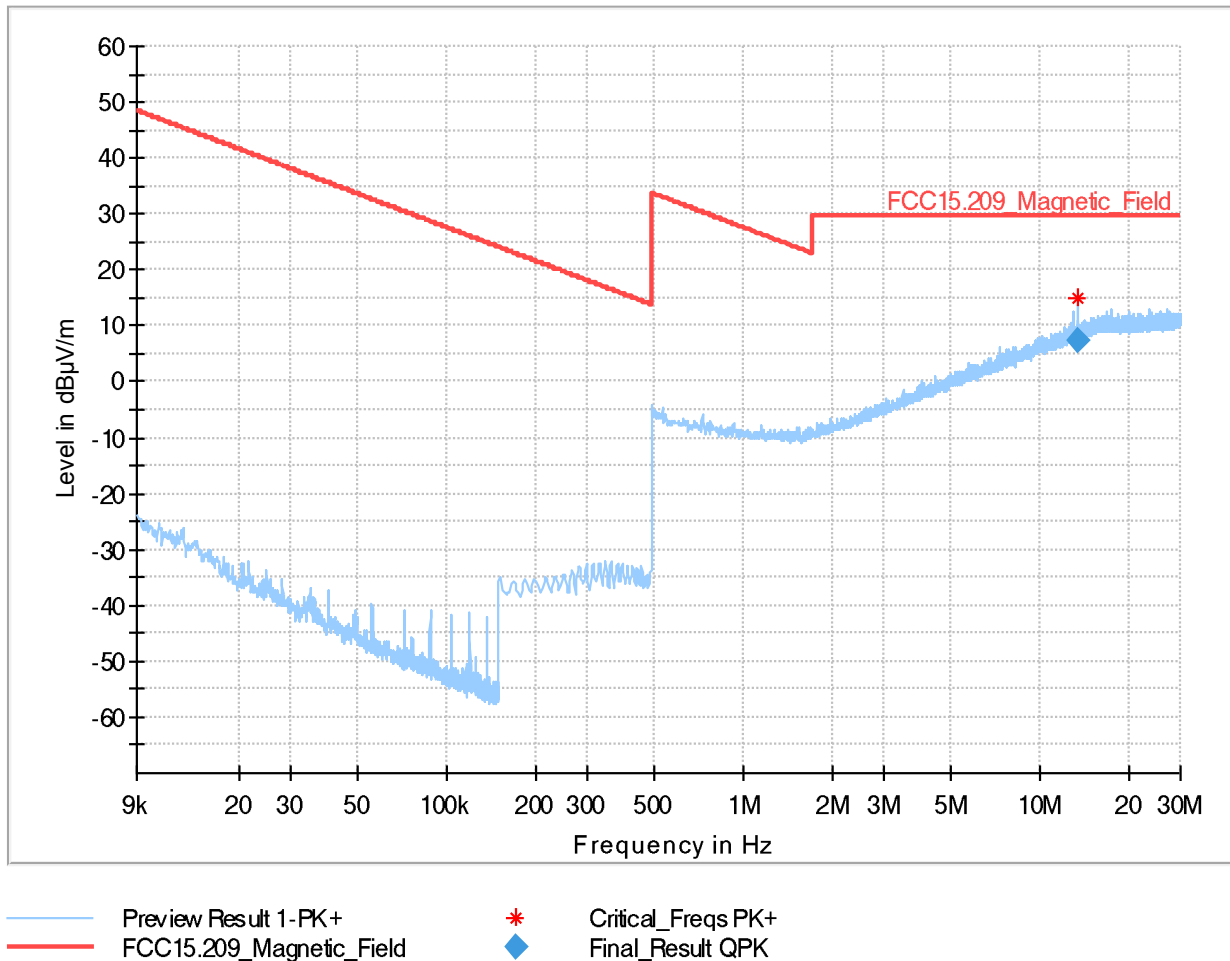

Final Result

Frequency (MHz)	QuasiPeak (dBµV/m)	Limit (dBµV/m)	Margin (dB)	Meas. Time (ms)	Bandwidth (kHz)	Pol	Azimuth (deg)	Corr. (dB)
13.560000	7.52	29.54	22.02	100.0	9.000	V	343.0	-0.9

Note:

The limits in CFR 47, Part 15, Subpart C, paragraph 15.209(a), are identical to those in RSS-GEN Section 8.9, Table 6, since the measurements are performed in terms of magnetic field strength and converted to electric field strength levels (as reported in the table) using the free space impedance of 377Ω. For example, the measurement frequency X kHz resulted in a level of Y dBµV/m, which is equivalent to $Y - 51.5 = Z$ dBµA/m, which has the same margin, W dB, to the corresponding RSS-GEN Table 6 limit as it has to the 15.209(a) limit.

(Certification & Engineering Bureau, Q&A on Certification Procedures and Requirements, TCB Workshop April 2020, Nicolas DesMarais, 2020-04-09 - ISED Q&A - DesMarais.pdf)

Plot 21: Mode 1, RSE 9 kHz – 30 MHz, mid channel, loop antenna

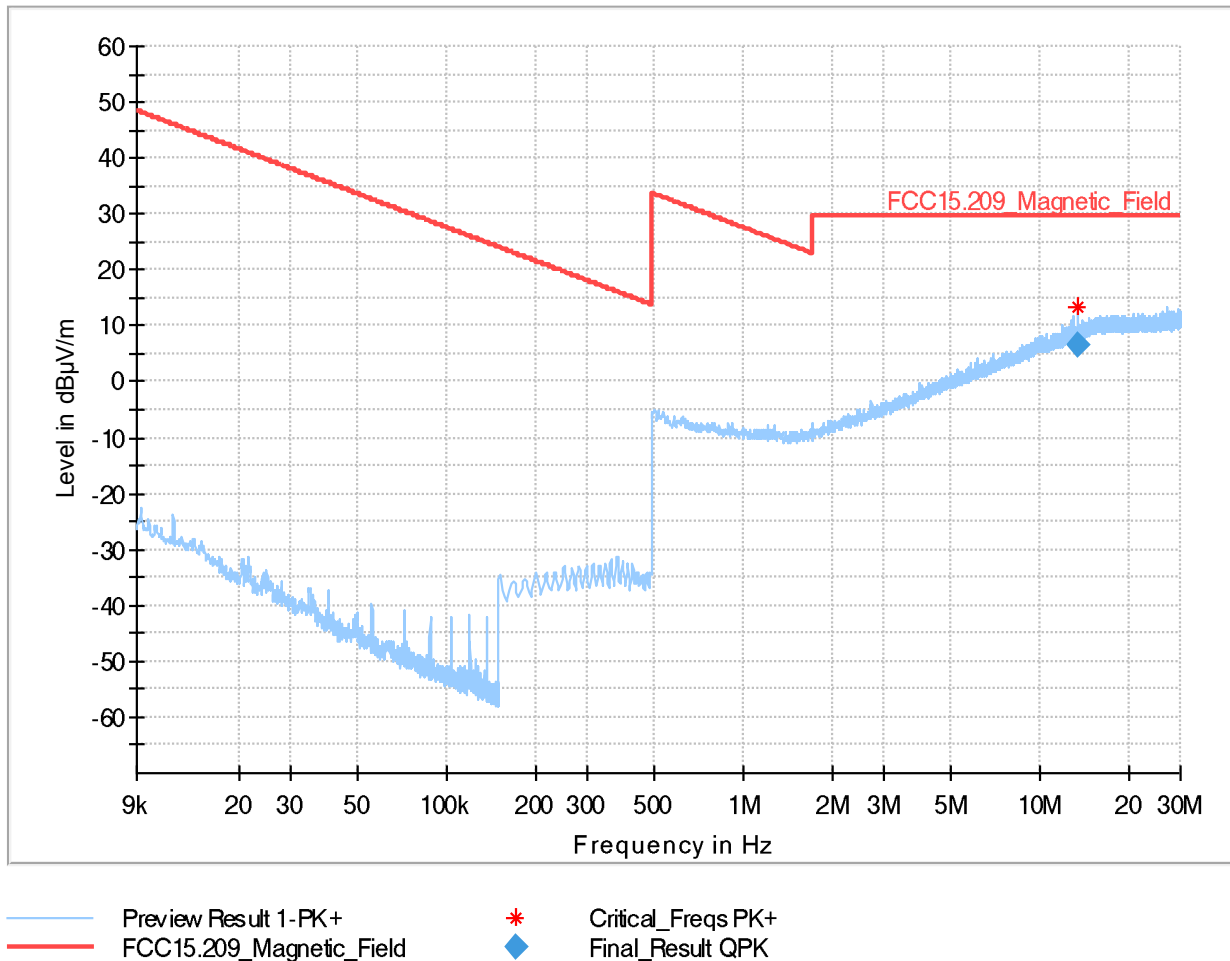

Final Result

Frequency (MHz)	QuasiPeak (dBµV/m)	Limit (dBµV/m)	Margin (dB)	Meas. Time (ms)	Bandwidth (kHz)	Pol	Azimuth (deg)	Corr. (dB)
13.560000	6.67	29.54	22.87	100.0	9.000	V	265.0	-0.9

Note:

The limits in CFR 47, Part 15, Subpart C, paragraph 15.209(a), are identical to those in RSS-GEN Section 8.9, Table 6, since the measurements are performed in terms of magnetic field strength and converted to electric field strength levels (as reported in the table) using the free space impedance of 377Ω. For example, the measurement frequency X kHz resulted in a level of Y dBµV/m, which is equivalent to $Y - 51.5 = Z$ dBµA/m, which has the same margin, W dB, to the corresponding RSS-GEN Table 6 limit as it has to the 15.209(a) limit.

(Certification & Engineering Bureau, Q&A on Certification Procedures and Requirements, TCB Workshop April 2020, Nicolas DesMarais, 2020-04-09 - ISED Q&A - DesMarais.pdf)

Plot 22: Mode 1, RSE 9 kHz – 30 MHz, high channel, loop antenna

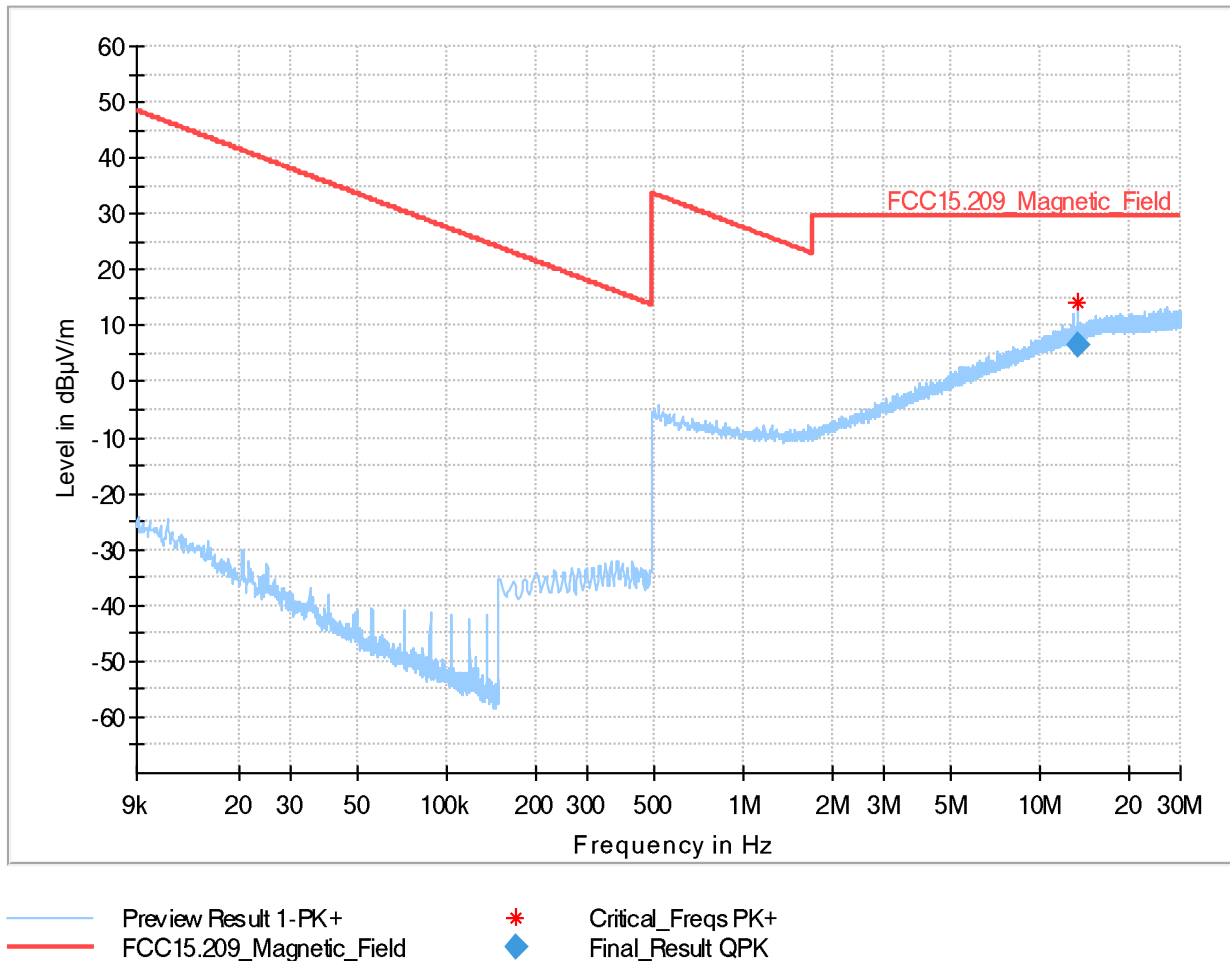

Final Result

Frequency (MHz)	QuasiPeak (dBµV/m)	Limit (dBµV/m)	Margin (dB)	Meas. Time (ms)	Bandwidth (kHz)	Pol	Azimuth (deg)	Corr. (dB/m)
13.560000	6.51	29.54	23.03	100.0	9.000	V	55.0	-0.9

Note:

The limits in CFR 47, Part 15, Subpart C, paragraph 15.209(a), are identical to those in RSS-GEN Section 8.9, Table 6, since the measurements are performed in terms of magnetic field strength and converted to electric field strength levels (as reported in the table) using the free space impedance of 377Ω. For example, the measurement frequency X kHz resulted in a level of Y dBµV/m, which is equivalent to $Y - 51.5 = Z$ dBµA/m, which has the same margin, W dB, to the corresponding RSS-GEN Table 6 limit as it has to the 15.209(a) limit.

(Certification & Engineering Bureau, Q&A on Certification Procedures and Requirements, TCB Workshop April 2020, Nicolas DesMarais, 2020-04-09 - ISED Q&A - DesMarais.pdf)

Plot 23: Mode 1, RSE 30 MHz – 1 GHz, low channel, horizontal / vertical polarisation

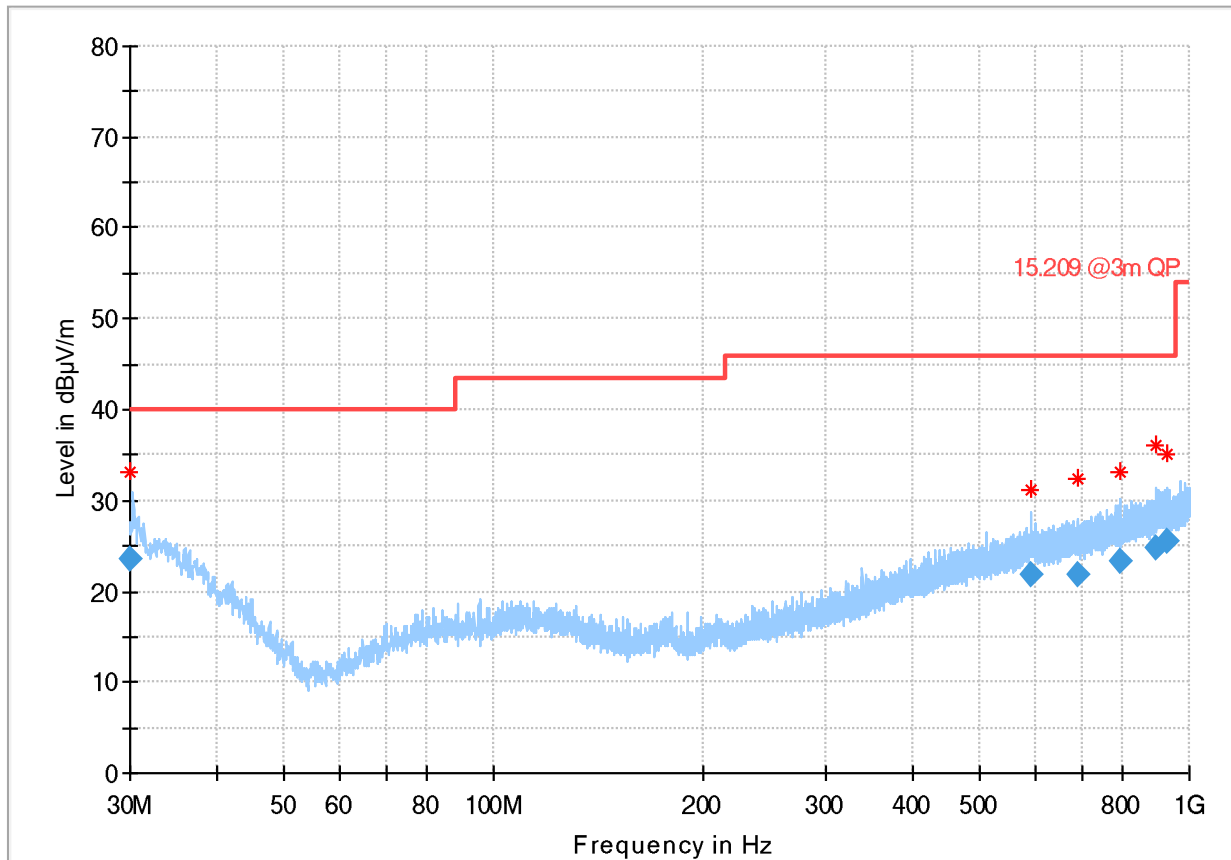

— Preview Result 1-PK+ * Critical_Freqs PK+
— 15.209 @3m QP ◆ Final_Result QPK

Final Result

Frequency (MHz)	QuasiPeak (dBµV/m)	Limit (dBµV/m)	Margin (dB)	Meas. Time (ms)	Bandwidth (kHz)	Height (cm)	Pol	Azimuth (deg)
30.060000	23.49	40.00	16.51	100.0	120.000	104.0	V	20.0
593.392500	21.84	46.00	24.16	100.0	120.000	119.0	V	335.0
690.660000	21.73	46.00	24.27	100.0	120.000	222.0	H	257.0
794.590500	23.35	46.00	22.65	100.0	120.000	250.0	H	106.0
895.023000	24.73	46.00	21.27	100.0	120.000	250.0	V	88.0
926.871500	25.45	46.00	20.55	100.0	120.000	350.0	H	179.0

Plot 24: Mode 1, RSE 30 MHz – 1 GHz, mid channel, horizontal / vertical polarisation

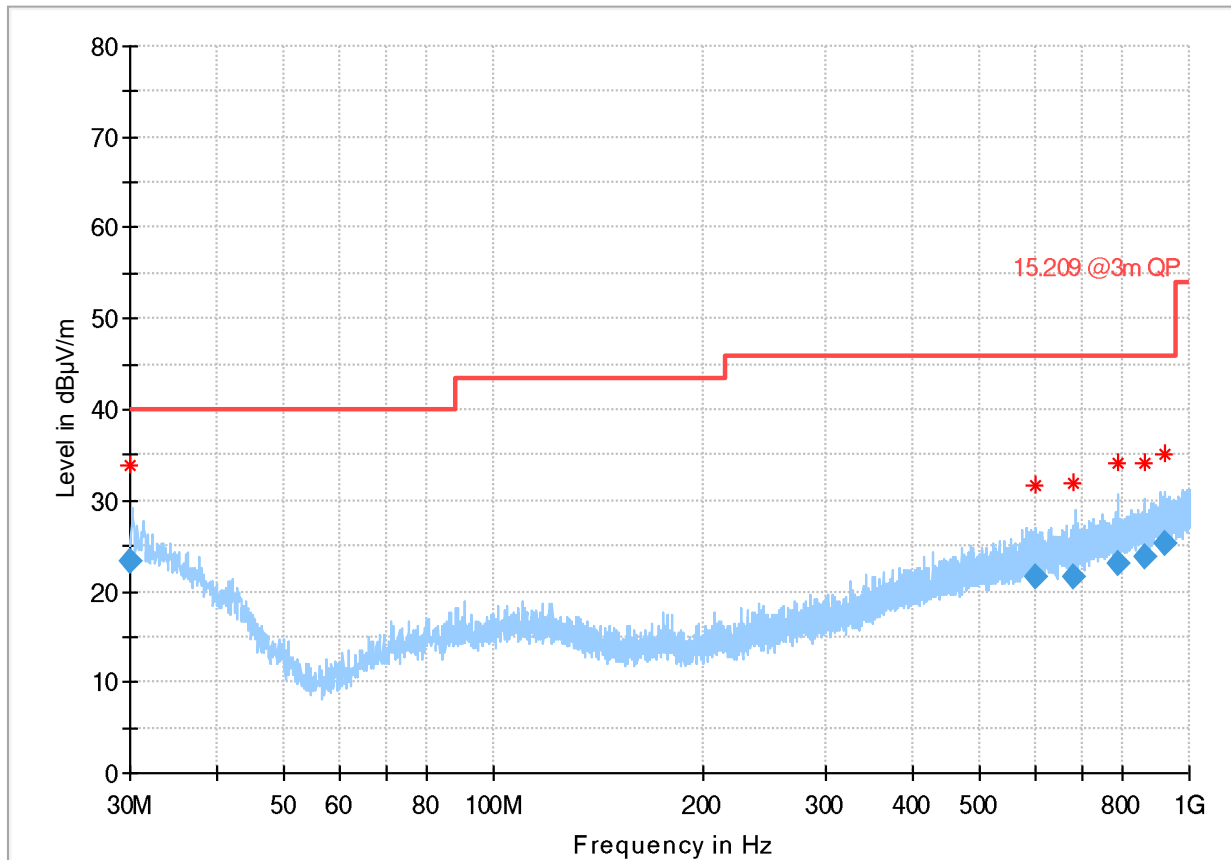

— Preview Result 1-PK+ * Critical_Freqs PK+
— 15.209 @3m QP ◆ Final_Result QPK

Final Result

Frequency (MHz)	QuasiPeak (dB μ V/m)	Limit (dB μ V/m)	Margin (dB)	Meas. Time (ms)	Bandwidth (kHz)	Height (cm)	Pol	Azimuth (deg)
30.060000	23.32	40.00	16.68	100.0	120.000	357.0	H	173.0
598.916500	21.60	46.00	24.40	100.0	120.000	357.0	V	137.0
683.512500	21.50	46.00	24.50	100.0	120.000	343.0	H	76.0
789.787500	23.06	46.00	22.94	100.0	120.000	100.0	V	131.0
865.715000	23.92	46.00	22.08	100.0	120.000	362.0	V	337.0
921.704500	25.31	46.00	20.69	100.0	120.000	270.0	H	182.0

Plot 25: Mode 1, RSE 30 MHz – 1 GHz, high channel, horizontal / vertical polarisation

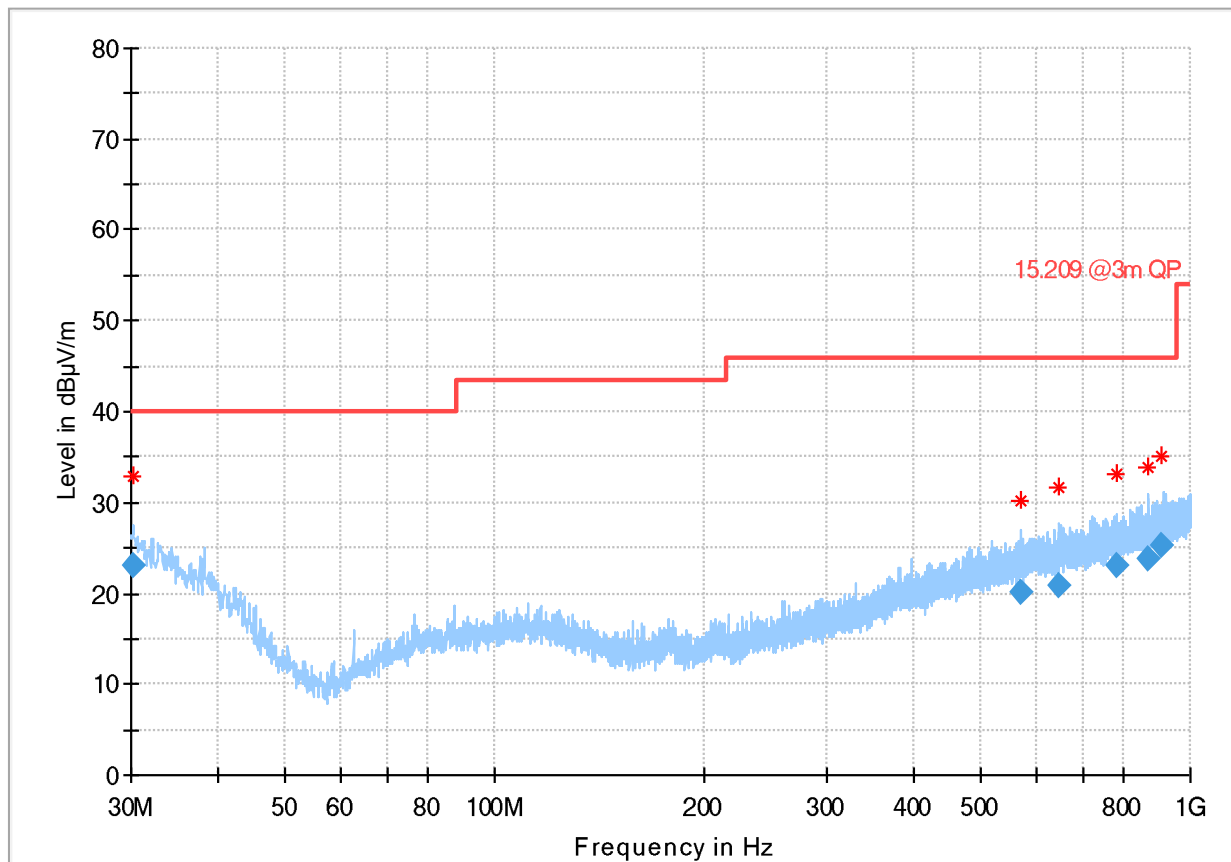

— Preview Result 1-PK+ * Critical_Freqs PK+
— 15.209 @3m QP ◆ Final_Result QPK

Final Result

Frequency (MHz)	QuasiPeak (dBµV/m)	Limit (dBµV/m)	Margin (dB)	Meas. Time (ms)	Bandwidth (kHz)	Height (cm)	Pol	Azimuth (deg)
30.330000	23.15	40.00	16.85	100.0	120.000	104.0	H	256.0
571.387500	20.17	46.00	25.83	100.0	120.000	132.0	H	207.0
648.996500	20.87	46.00	25.13	100.0	120.000	272.0	V	233.0
785.635000	22.97	46.00	23.03	100.0	120.000	103.0	V	137.0
869.167500	23.89	46.00	22.11	100.0	120.000	362.0	V	351.0
911.783500	25.21	46.00	20.79	100.0	120.000	241.0	V	261.0

Plot 26: Mode 1, RSE 1 GHz – 18 GHz, low channel, horizontal / vertical polarisation

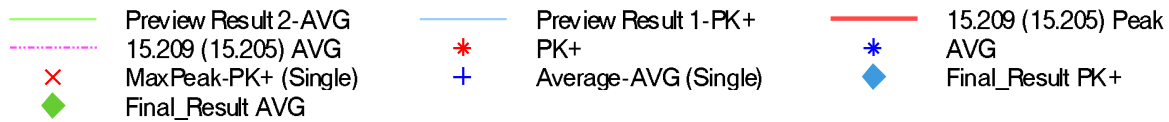
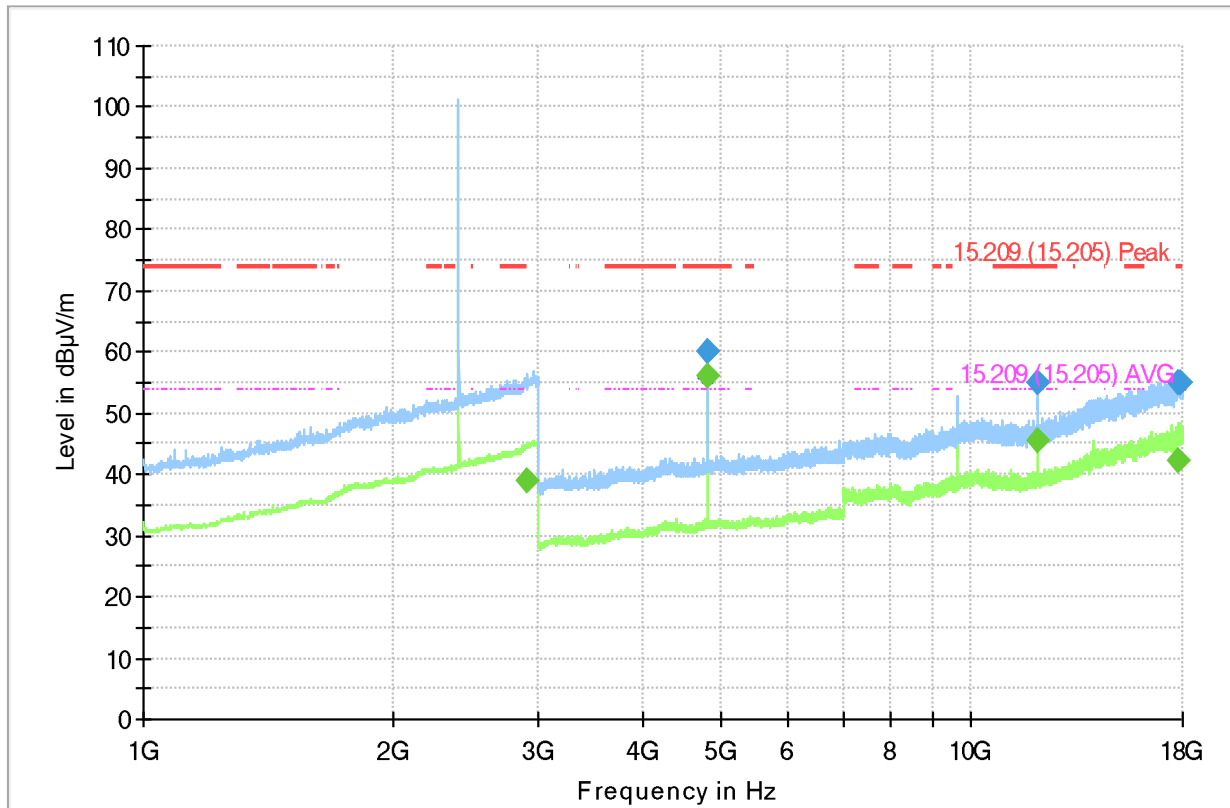

Final Result

Frequency (MHz)	MaxPeak (dBµV/m)	Average (dBµV/m)	Limit (dBµV/m)	Margin (dB)	Meas. Time (ms)	Bandwidth (kHz)	Height (cm)	Pol
2898.870000	---	39.08	54.00	14.92	1000.0	1000.000	150.0	H
4803.805000	---	56.20	54.00	-2.20	1000.0	1000.000	150.0	V
4804.397500	60.26	---	74.00	13.74	1000.0	1000.000	150.0	V
12008.944167	---	45.39	54.00	8.61	1000.0	1000.000	150.0	H
12011.364167	55.10	---	74.00	18.90	1000.0	1000.000	150.0	H
17765.933333	54.96	---	74.00	19.04	1000.0	1000.000	150.0	V
17767.102500	---	42.16	54.00	11.84	1000.0	1000.000	150.0	V
17854.039167	54.95	---	74.00	19.05	1000.0	1000.000	150.0	H

Note:

With a declared duty cycle (DC) of max. 50% a DC correction factor (DCCF) of -3 dB has to be considered for harmonics shown in above plots (not yet included).

Informative: When transmitting with 4 dBm Tx power, following values are measured for 2nd harmonic: 56.3 dBµV/m Peak / 52.5 dBµV/m AVG.

Plot 27: Mode 1, RSE 1 GHz – 18 GHz, mid channel, horizontal / vertical polarisation

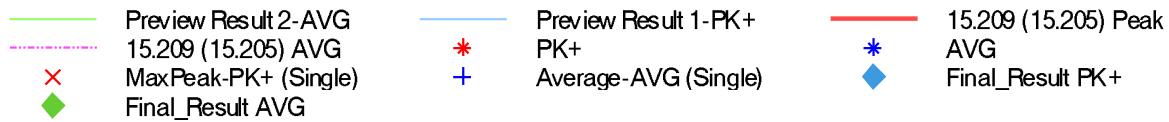
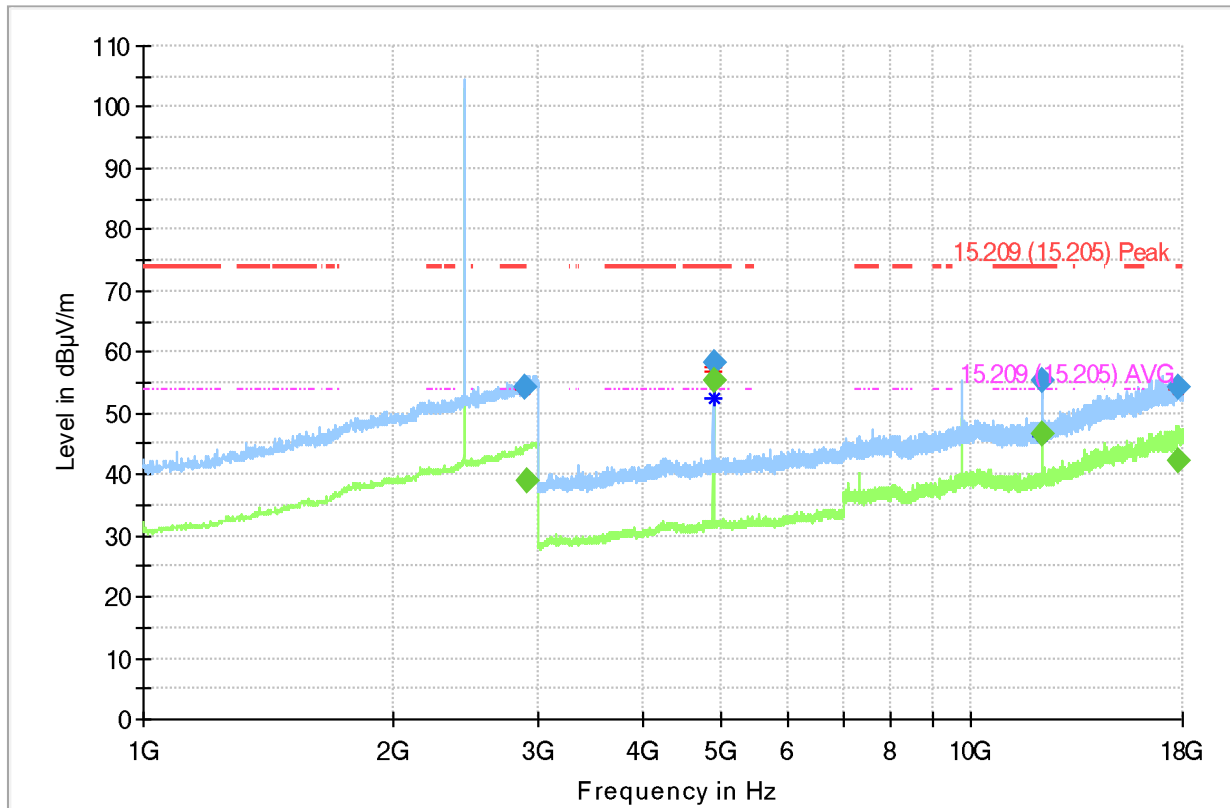

Final Result

Frequency (MHz)	MaxPeak (dBµV/m)	Average (dBµV/m)	Limit (dBµV/m)	Margin (dB)	Meas. Time (ms)	Bandwidth (kHz)	Height (cm)	Pol
2894.285000	54.28	---	74.00	19.72	1000.0	1000.000	150.0	H
2899.745000	---	39.07	54.00	14.93	1000.0	1000.000	150.0	V
4879.590000	---	55.20	54.00	-1.20	1000.0	1000.000	150.0	V
4880.427500	58.14	---	74.00	15.86	1000.0	1000.000	150.0	V
12198.991667	---	46.46	54.00	7.54	1000.0	1000.000	150.0	H
12201.205833	55.45	---	74.00	18.55	1000.0	1000.000	150.0	H
17799.384166	54.15	---	74.00	19.85	1000.0	1000.000	150.0	H
17820.750000	---	42.10	54.00	11.90	1000.0	1000.000	150.0	H

Note:

With a declared duty cycle (DC) of max. 50% a DC correction factor (DCCF) of -3 dB has to be considered for harmonics shown in above plots (not yet included).

Informative: When transmitting with 4 dBm Tx power, following values are measured for 2nd harmonic: 55.3 dBµV/m Peak / 51.8 dBµV/m AVG.

Plot 28: Mode 1, RSE 1 GHz – 18 GHz, high channel, horizontal / vertical polarisation

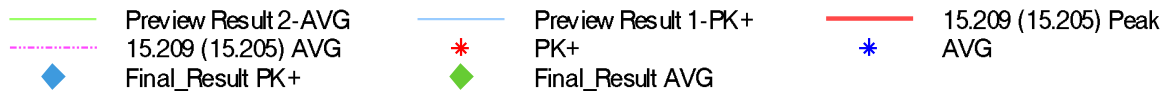
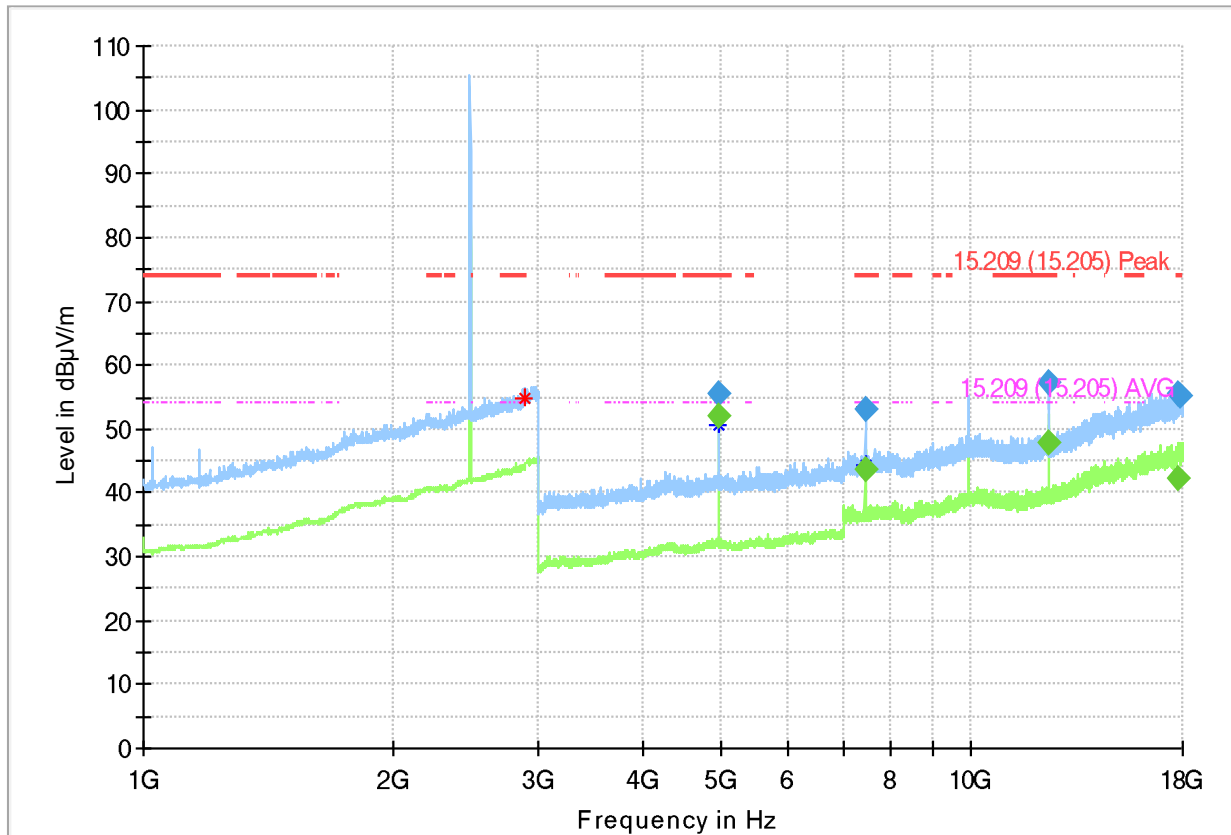

Final Result

Frequency (MHz)	MaxPeak (dBµV/m)	Average (dBµV/m)	Limit (dBµV/m)	Margin (dB)	Meas. Time (ms)	Bandwidth (kHz)	Height (cm)	Pol
4959.657500	55.60	---	74.00	18.40	1000.0	1000.000	150.0	H
4959.777500	---	51.90	54.00	2.10	1000.0	1000.000	150.0	H
7439.339166	---	43.52	54.00	10.48	1000.0	1000.000	150.0	H
7440.691666	53.01	---	74.00	20.99	1000.0	1000.000	150.0	H
12398.690000	---	47.71	54.00	6.29	1000.0	1000.000	150.0	H
12401.181667	57.30	---	74.00	16.70	1000.0	1000.000	150.0	H
17760.750000	55.35	---	74.00	18.65	1000.0	1000.000	150.0	V
17765.193333	---	42.21	54.00	11.79	1000.0	1000.000	150.0	V
17916.567500	55.16	---	74.00	18.84	1000.0	1000.000	150.0	H

Note:

With a declared duty cycle (DC) of max. 50% a DC correction factor (DCCF) of -3 dB has to be considered for harmonics shown in above plots (not yet included).

Informative: When transmitting with 4 dBm Tx power, following values are measured for 2nd harmonic: 52.4 dBµV/m Peak / 47.8 dBµV/m AVG.

Plot 29: Mode 1, RSE 18 GHz – 26 GHz, low channel, horizontal / vertical polarisation

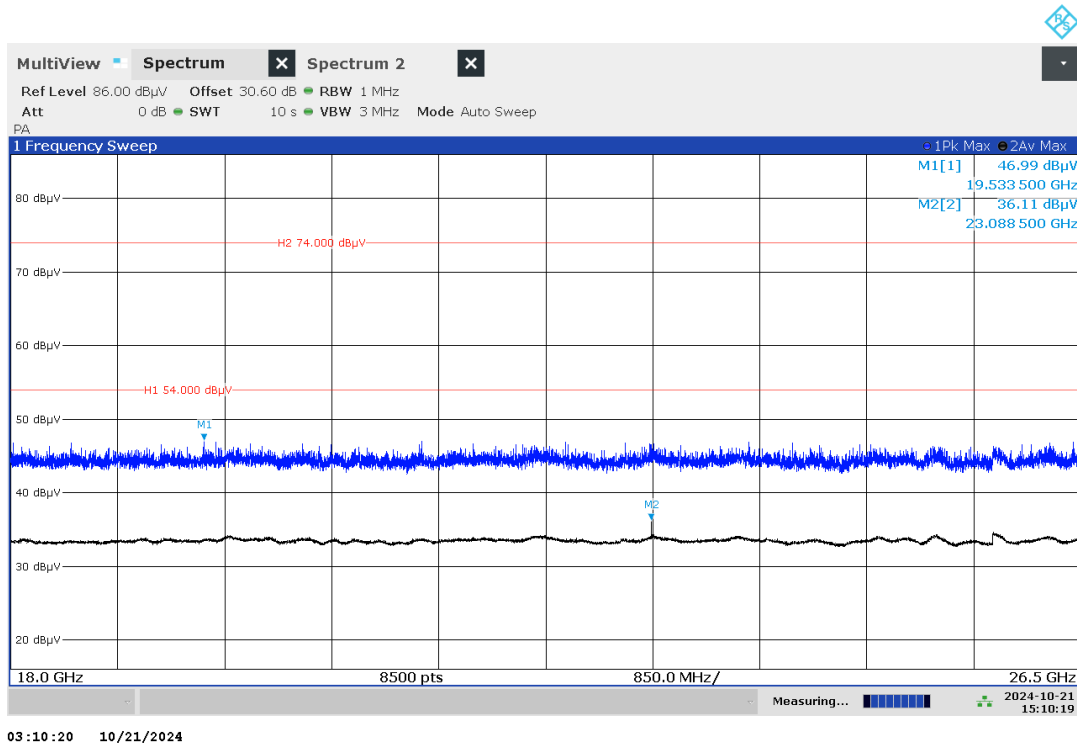

Plot 30: Mode 1, RSE 18 GHz – 26 GHz, mid channel, horizontal / vertical polarisation

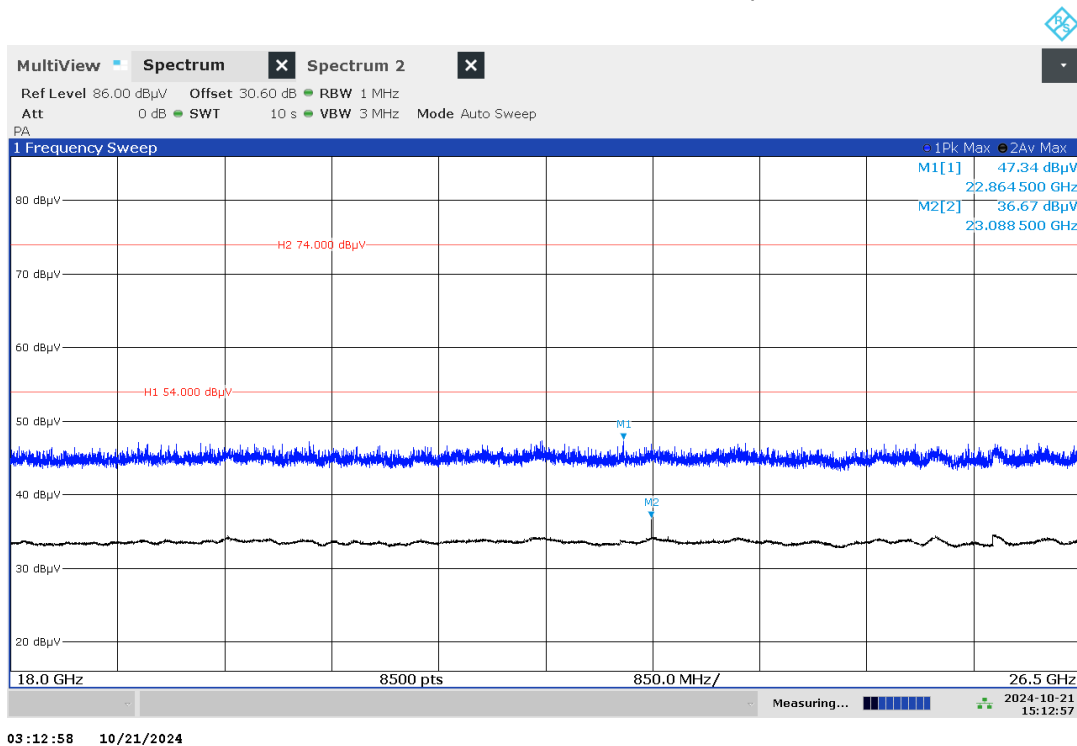

Plot 31: Mode 1, RSE 18 GHz – 26 GHz, high channel, horizontal / vertical polarisation

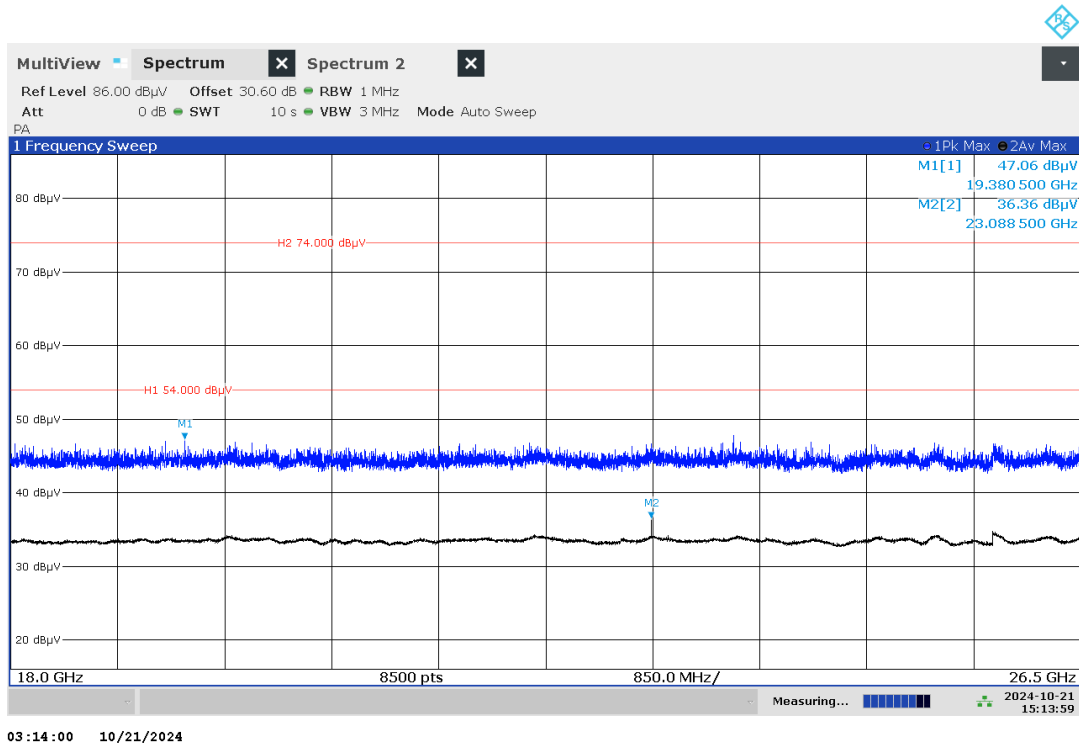

8 TEST SETUP DESCRIPTION

Typically, the calibrations of the test apparatus are commissioned to and performed by an accredited calibration laboratory. The calibration intervals are determined in accordance with the DIN EN ISO/IEC 17025. In addition to the external calibrations, the laboratory executes comparison measurements with other calibrated test systems or effective verifications. Cyclic chamber inspections and range calibrations are performed. Where possible, RF generating and signalling equipment as well as measuring receivers and analysers are connected to an external high-precision 10 MHz reference (GPS-based or rubidium frequency standard).

In order to simplify the identification of the equipment used at some special tests, some items of test equipment and ancillaries can be provided with an identifier or number in the equipment list below (Lab/Item).

Kind of calibration (abbreviations):

- C = calibrated
- CM = cyclic maintenance
- NR = not required
- L = locked

8.1 Semi Anechoic Chamber with Ground Plane

Radiated measurements are performed in vertical and horizontal plane in the frequency range 30 MHz to 1 GHz in a Semi Anechoic Chamber with a metallic ground plane. The EUT is positioned on a non-conductive test table with a height of 0.80 m above the metallic ground plane that covers the whole chamber. The receiving antennas conform to specification ANSI C63.10-2013, American National Standard for Testing Unlicensed Wireless Devices. These antennas can be moved over the height range between 1.0 m and 4.5 m in order to search for maximum field strength emitted from the EUT. The measurement distances between EUT and receiving antennas are indicated in the test setups for the various frequency ranges. For each measurement, the EUT is rotated in all three axes until the maximum field strength is received. The wanted and unwanted emissions are received by a spectrum analyzer where the detector modes and resolution bandwidths over various frequency ranges are set according to requirement ANSI C63.

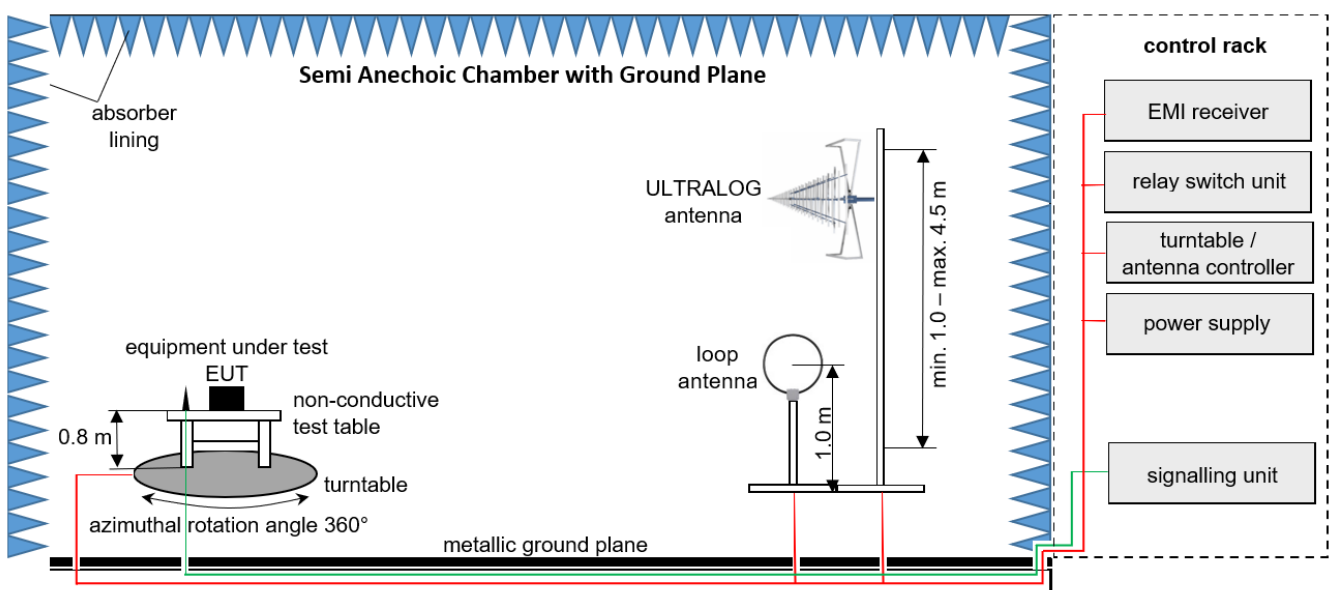

Measurement distance: loop antenna at 3 m, ULTRALOG antenna at 3 m
 EMC32 software version: 11.20.00

$$FS = UR + CL + AF$$

(FS-field strength; UR-voltage at the receiver; CL-loss of the cable; AF-antenna factor)

Example calculation:

$$FS \text{ [dB}\mu\text{V/m]} = 12.35 \text{ [dB}\mu\text{V/m]} + 1.90 \text{ [dB]} + 16.80 \text{ [dB/m]} = 31.05 \text{ [dB}\mu\text{V/m]} \text{ (35.69 } \mu\text{V/m)}$$

List of test equipment used:

No.	Equipment	Manufacturer	Type	Serial No.	IBL No.	Kind of Calibration	Last / Next Calibration
1	Power Supply	Rohde & Schwarz	IN 600	101554	LAB000824	NR	–
2	Antenna	Rohde & Schwarz	HL562E	102173	LAB000673	C	2022-10-17 → 36M → 2025-10-17
3	Power Supply	Chroma	61602		LAB000507	NR	–
4	Power Supply	Elektro-Automatik GmbH & Co. KG	EA-PSI 9080-40 T	2000230001	LAB000313	NR	–
5	Test table	innco systems GmbH	PT1208-080-RH	-	LAB000306	NR	–
6	Antenna Mast	Berlebach	Tripod HFH2-Z8 & -Z9	101762	LAB000292	NR	–
7	Positioner	matur GmbH	TD 1.5-10KG		LAB000258	NR	–
8	Compressed Air	Implotex	1-850-30	-	LAB000256	NR	–
9	EMI Test Receiver	Rohde & Schwarz	ESW26	101481	LAB000236	C	2024-07-18 → 12M → 2025-07-18
10	Semi/Fully Anechoic Chamber	Albatross Projects GmbH	Babylon 5 (SAC 5)	20168.PRB	LAB000235	CM	2022-01-31 → 36M → 2025-01-31
11	Measurement Software	Rohde & Schwarz	EMC32 V11.20		LAB000226	NR	–
12	Turntable	matur GmbH	TT2.0-2t	TT2.0-2t/921	LAB000225	NR	–
13	Antenna Mast	matur GmbH	CAM4.0-P	CAM4.0-P/316	LAB000224	NR	–
14	Antenna Mast	matur GmbH	BAM4.5-P	BAM4.5-P/272	LAB000223	NR	–
15	Controller	matur GmbH	FCU 3.0	10082	LAB000222	NR	–
16	Power Supply	Elektro-Automatik GmbH & Co. KG	EA-PS 2042-10 B	2878350292	LAB000191	NR	–
17	Pre-Amplifier	Schwarzbeck Mess-Elektronik OHG	BBV 9718 C	84	LAB000169	CM	2022-05-31 → 36M → 2025-05-31
18	Antenna	Rohde & Schwarz	HF907	102899	LAB000151	C	2023-05-15 → 36M → 2026-05-15
19	Antenna	Rohde & Schwarz	HL562E	102005	LAB000150	C	2022-12-22 → 36M → 2025-12-22
20	Open Switch and Control Platform	Rohde & Schwarz	OSP220 Base Unit 2HU	101748	LAB000149	NR	–
21	Antenna	Rohde & Schwarz	HFH2-Z2E	100954	LAB000108	C	2023-05-05 → 36M → 2026-05-05

8.2 Fully Anechoic Chamber

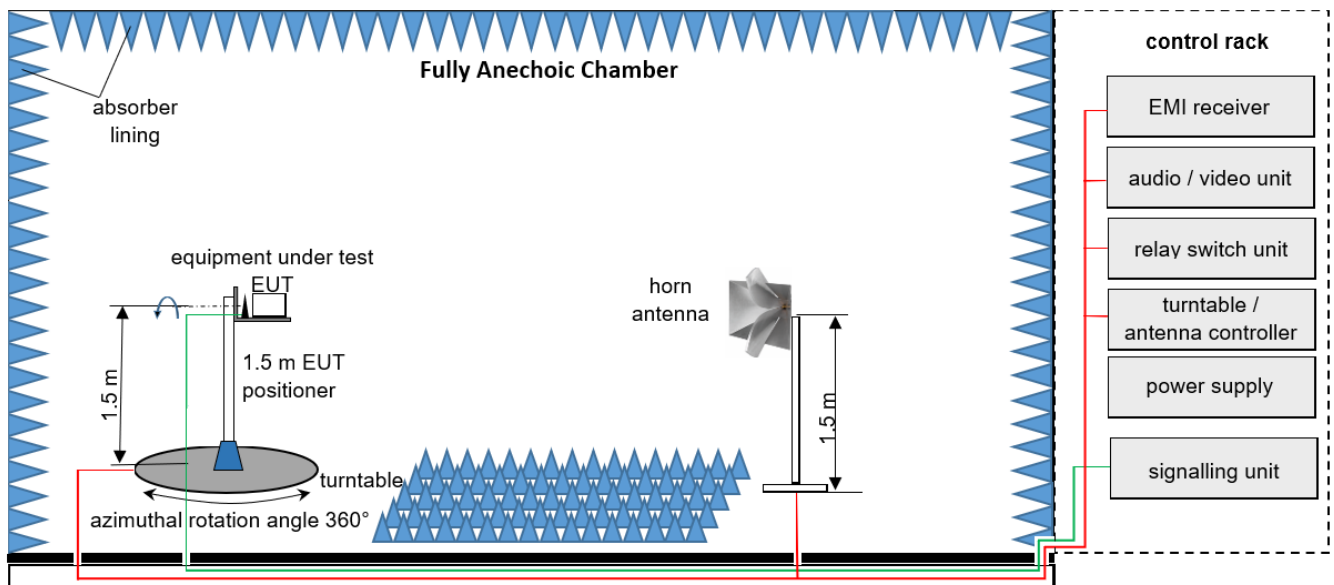

Measurement distance: horn antenna at 3 m

EMC32 software version: 11.20.00

$$FS = UR + CL + AF$$

(FS-field strength; UR-voltage at the receiver; CL-loss of the cable; AF-antenna factor)

Example calculation:

$$FS [dB\mu V/m] = 12.35 [dB\mu V/m] + 1.90 [dB] + 16.80 [dB/m] = 31.05 [dB\mu V/m] (35.69 \mu V/m)$$

$$OP = AV + D - G + CA$$

(OP-radiated output power; AV-analyzer value; D-free field attenuation of measurement distance; G-antenna gain+amplifier gain; CA-loss signal path)

Example calculation:

$$OP [dBm] = -65.0 [dBm] + 50 [dB] - 20 [dBi] + 5 [dB] = -30 [dBm] (1 \mu W)$$

List of test equipment used:

No.	Equipment	Manufacturer	Type	Serial No.	IBL No.	Kind of Calibration	Last / Next Calibration
1	Power Supply	Rohde & Schwarz	IN 600	101554	LAB000824	NR	–
2	Antenna	Rohde & Schwarz	HL562E	102173	LAB000673	C	2022-10-17 → 36M → 2025-10-17
3	Power Supply	Chroma	61602		LAB000507	NR	–
4	Power Supply	Elektro-Automatik GmbH & Co. KG	EA-PSI 9080-40 T	2000230001	LAB000313	NR	–
5	Test table	innco systems GmbH	PT1208-080-RH	-	LAB000306	NR	–
6	Antenna Mast	Berlebach	Tripod HFH2-Z8 & -Z9	101762	LAB000292	NR	–
7	Positioner	matur GmbH	TD 1.5-10KG		LAB000258	NR	–
8	Compressed Air	Implotex	1-850-30	-	LAB000256	NR	–
9	EMI Test Receiver	Rohde & Schwarz	ESW26	101481	LAB000236	C	2024-07-18 → 12M → 2025-07-18
10	Semi/Fully Anechoic Chamber	Albatross Projects GmbH	Babylon 5 (SAC 5)	20168.PRB	LAB000235	CM	2022-01-31 → 36M → 2025-01-31
11	Measurement Software	Rohde & Schwarz	EMC32 V11.20		LAB000226	NR	–
12	Turntable	matur GmbH	TT2.0-2t	TT2.0-2t/921	LAB000225	NR	–
13	Antenna Mast	matur GmbH	CAM4.0-P	CAM4.0-P/316	LAB000224	NR	–
14	Antenna Mast	matur GmbH	BAM4.5-P	BAM4.5-P/272	LAB000223	NR	–
15	Controller	matur GmbH	FCU 3.0	10082	LAB000222	NR	–
16	Power Supply	Elektro-Automatik GmbH & Co. KG	EA-PS 2042-10 B	2878350292	LAB000191	NR	–
17	Pre-Amplifier	Schwarzbeck Mess-Elektronik OHG	BBV 9718 C	84	LAB000169	CM	2022-05-31 → 36M → 2025-05-31
18	Antenna	Rohde & Schwarz	HF907	102899	LAB000151	C	2023-05-15 → 36M → 2026-05-15
19	Antenna	Rohde & Schwarz	HL562E	102005	LAB000150	C	2022-12-22 → 36M → 2025-12-22
20	Open Switch and Control Platform	Rohde & Schwarz	OSP220 Base Unit 2HU	101748	LAB000149	NR	–
21	Antenna	Rohde & Schwarz	HFH2-Z2E	100954	LAB000108	C	2023-05-05 → 36M → 2026-05-05

8.3 Radiated measurements > 18 GHz

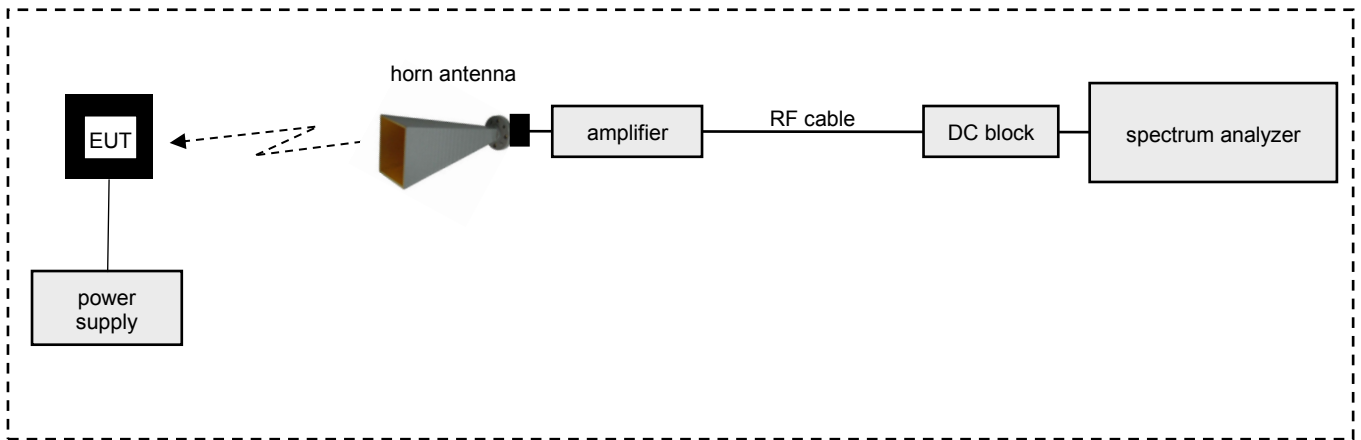

List of test equipment used:

No.	Equipment	Manufacturer	Type	Serial No.	IBL No.	Kind of Calibration	Last / Next Calibration
1	Absorber	Telemeter Electronic	EPP 12	-	LAB000327	NR	-
2	Test table	innco systems GmbH	PT0707-RH light	-	LAB000303	NR	-
3	Spectrum Analyser	Rohde & Schwarz	FSW43	101391	LAB000289	C	2024-06-04 → 12M → 2025-06-04
4	Power Supply	Elektro-Automatik GmbH & Co. KG	EA-PS 2042-10 B	2878350263	LAB000190	NR	-
5	WG-Coax-Adapter	Flann Microwave Ltd	22093-TF30 UG599/U	273263	LAB000183	CM	2024-07-16 → 12M → 2025-07-16
6	WG-Coax-Adapter	Flann Microwave Ltd	20093-TF30 UBR220	273374	LAB000181	CM	2024-07-16 → 12M → 2025-07-16
7	Coaxial Cable	Huber & Suhner	SF101/1.5m	503987/1	LAB000165	CM	2024-07-17 → 12M → 2025-07-17
8	Antenna	Flann Microwave Ltd	22240-20 (26.5-40.0 GHz)	270448	LAB000130	CM	2024-07-16 → 12M → 2025-07-16
9	Antenna	Flann Microwave Ltd	20240-20 (18.0-26.5 GHz)	266403	LAB000128	CM	2024-07-16 → 12M → 2025-07-16
10	Antenna Mast	Schwarzbeck Mess-Elektronik OHG	AM 9104	99	LAB000109	NR	-
11	Multimeter	Keysight	U1242B	MY59110034	LAB000009	C	2024-08-06 → 12M → 2025-08-06

8.4 Conducted measurements WLAN test system R&S TS 8997

The EUT's RF signal is coupled out by the antenna connector which is supplied by the manufacturer. The losses for all signal paths are first checked within a calibration. The measurement readings on the signalling unit/spectrum analyzer are corrected by the specific test set-up loss. The attenuator, power divider, signalling unit and the spectrum analyzer are impedance matched on 50 Ohm.

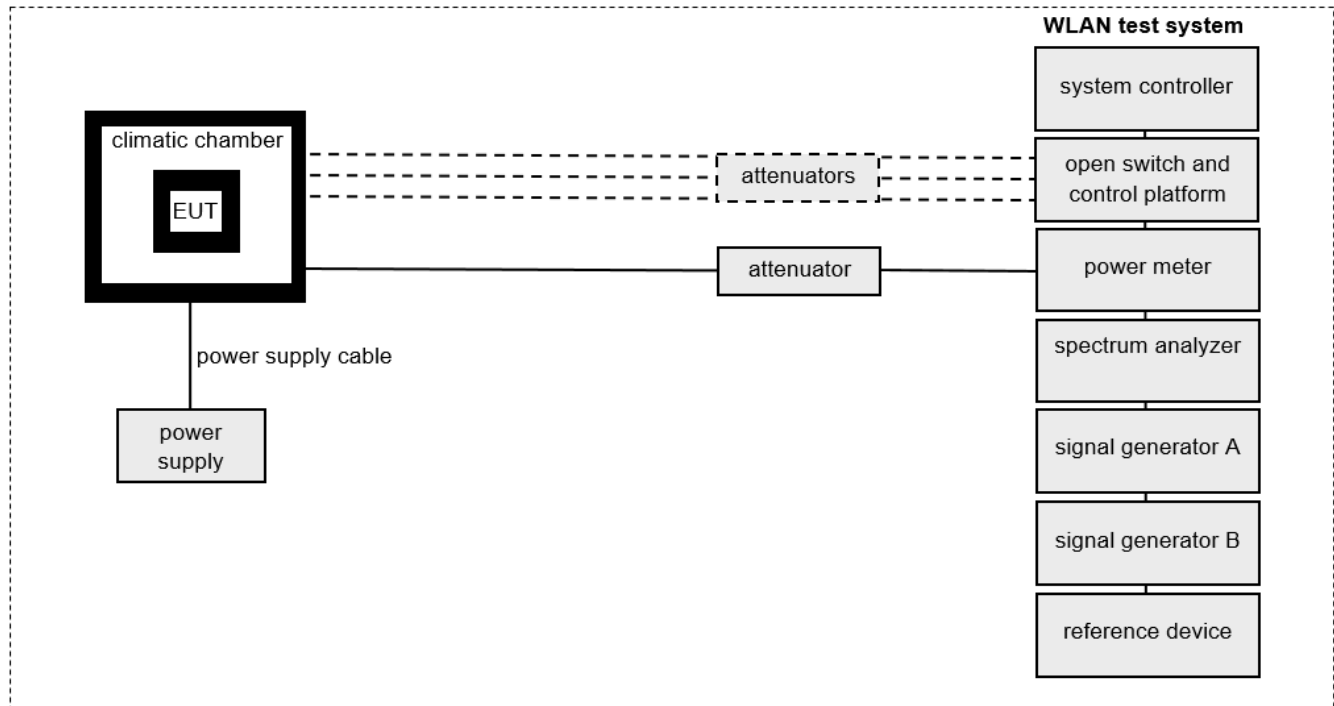

EMC32/WMS32 software version: 12.00.00

List of test equipment used:

No.	Equipment	Manufacturer	Type	Serial No.	IBL No.	Kind of Calibration	Last / Next Calibration
1	RF Shield Box	Rohde & Schwarz	CMW-Z10	101612	LAB000693	NR	–
2	Open Switch and Control Platform	Rohde & Schwarz	OSP-B157W8Plus	100830	LAB000358	C	2024-03-26 → 36M → 2025-03-26
3	TS8997	Rohde & Schwarz	TS8997-Rack	100829	LAB000322	NR	–
4	Open Switch and Control Platform	Rohde & Schwarz	OSP-B157WX	101247	LAB000280	NR	–
5	Spectrum Analyser	Rohde & Schwarz	FSV40	101403	LAB000278	C	2024-04-10 → 12M → 2025-04-10
6	Vector Signal Generator	Rohde & Schwarz	SMBV100A-06	258240	LAB000277	C	2024-09-17 → 12M → 2025-09-17
7	Signal Generator	Rohde & Schwarz	SMB100A-20	178175	LAB000276	C	2024-04-03 → 12M → 2025-04-03
8	Radio Communication Tester	Rohde & Schwarz	CMW270	101479	LAB000275	NR	–
9	Controller	Hewlett Packard	ATS-Z230	101379	LAB000274	NR	–
10	Power Supply	Elektro-Automatik GmbH & Co. KG	EA-PS 2042-10 B	2878350263	LAB000190	NR	–
11	Climatic Chamber	CTS GmbH	T-65/50	204002	LAB000110	CM	2024-06-07 → 12M → 2025-06-07
12	Multimeter	Keysight	U1242B	MY59110034	LAB000009	C	2024-08-06 → 12M → 2025-08-06

9 MEASUREMENT PROCEDURES

9.1 Radiated spurious emissions from 9 kHz to 30 MHz

Test setup

- The EUT is set up according to its intended use, as described in the user manual or as defined by the manufacturer.
- In case of floor standing equipment, it is placed in the middle of the turn table.
In case of tabletop equipment it is placed on a non-conductive table with a height of 80 cm.
- Additional equipment, cables, ... necessary for testing, are positioned like under normal operation.
- Interface cables, e.g. power supply, network, ... are connected to the connection box in the turn table.
- EUT is powered on and set into operation.

Pre-scan

- Turntable performs an azimuthal rotation from 0° to 360° continuously.
- For each turntable position the EMI-receiver/spectrum analyser performs a positive-peak/max-hold sweep (=worst-case). Data is transferred to EMI-software and recorded. EMI-software will show the maximum level of all single sweeps as the final result for the pre-scan.

Final measurement

- Significant emissions found during the pre-scan will be maximized by the EMI-software by rotating the turntable from 0° to 360°.
- Loop antenna is rotated with special 3D adapter set to find maximum level of emissions.
- Plot of the pre-scan with frequencies of identified emissions including levels, correction factors, turn table position and settings of measuring equipment is recorded.

Distance correction (extrapolation)

- When performing measurements on test distances other than defined in the rules, the results shall be extrapolated to the specified distance by conservatively presuming that the field strength decays at 40 dB/decade of distance in the region closer than λ in m divided by 2π (i.e., $\lambda/2\pi$), and at 20 dB/decade of distance beyond that, using the measurement of a single point at the radial angle that produces the maximum emission.

This correction is already included in the limit line of corresponding measurement plots.

Detailed requirements can be found in e.g. ANSI C63.4 / C63.10

9.2 Radiated spurious emissions from 30 MHz to 1 GHz

Test setup

- The EUT is set up according to its intended use, as described in the user manual or as defined by the manufacturer.
- In case of floor standing equipment, it is placed in the middle of the turn table.
In case of tabletop equipment it is placed on a non-conductive table with a height of 80 cm.
- Additional equipment, cables, ... necessary for testing, are positioned like under normal operation.
- Interface cables, e.g. power supply, network, ... are connected to the connection box in the turn table.
- EUT is powered on and set into operation.

Pre-scan

- Turntable performs an azimuthal rotation from 0° to 360° continuously.
- Antenna polarisation is changed (H-V / V-H) and antenna height is changed from 1 meter to 4 meters.
- For each turntable position / antenna polarisation / antenna height the EMI-receiver/spectrum analyser performs a positive-peak/max-hold sweep (=worst-case). Data is transferred to EMI-software and recorded. EMI-software will show the maximum level of all single sweeps as the final result for the pre-scan.

Final measurement

- Significant emissions found during the pre-scan will be maximized by the EMI-software based on evaluated data during the pre-scan by rotating the turntable and changing antenna height and polarisation.
- Final measurement will be performed with measuring equipment settings as defined in the applicable test standards (e.g. ANSI C6.4).
- Plot of the pre-scan with frequencies of identified emissions including levels, correction factors, turn table position, antenna polarisation and settings of measuring equipment is recorded.

Distance correction (extrapolation)

- When performing measurements on test distances other than defined in the rules, the results shall be extrapolated to the specified distance by conservatively presuming that the field strength decays at 20 dB/decade of distance beyond the region λ in m divided by 2π (i.e., $\lambda/2\pi$), using the measurement of a single point at the radial angle that produces the maximum emission.
This correction is already included in the corresponding measurement plots.

Detailed requirements can be found in e.g. ANSI C63.4 / C63.10

9.3 Radiated spurious emissions from 1 GHz to 18 GHz

Test setup

- The EUT is set up according to its intended use, as described in the user manual or as defined by the manufacturer.
- In case of floor standing equipment, it is placed in the middle of the turn table.
In case of tabletop equipment it is placed on a non-conductive table with a height of 80 cm.
- Additional equipment, cables, ... necessary for testing, are positioned like under normal operation.
- Interface cables, e.g. power supply, network, ... are connected to the connection box in the turn table.
- EUT is powered on and set into operation.

Pre-scan

- Turntable performs an azimuthal rotation from 0° to 360° continuously.
- Antenna polarisation is changed (H-V / V-H) and antenna height is changed from 1 meter to 4 meters.
- For each turntable position / antenna polarisation / antenna height the EMI-receiver/spectrum analyser performs a positive-peak/max-hold sweep (=worst-case). Data is transferred to EMI-software and recorded. EMI-software will show the maximum level of all single sweeps as the final result for the pre-scan.

Final measurement

- Significant emissions found during the pre-scan will be maximized by the EMI-software based on evaluated data during the pre-scan by rotating the turntable and changing antenna height and polarisation.
- Final measurement will be performed with measuring equipment settings as defined in the applicable test standards (e.g. ANSI C6.4).
- Plot of the pre-scan with frequencies of identified emissions including levels, correction factors, turn table position, antenna polarisation and settings of measuring equipment is recorded.

Distance correction (extrapolation)

- When performing measurements on test distances other than defined in the rules, the results shall be extrapolated to the specified distance by conservatively presuming that the field strength decays at 20 dB/decade of distance beyond the region λ in m divided by 2π (i.e., $\lambda/2\pi$), using the measurement of a single point at the radial angle that produces the maximum emission.
This correction is already included in the corresponding measurement plots.

Detailed requirements can be found in e.g. ANSI C63.4 / C63.10

9.4 Radiated spurious emissions above 18 GHz

Test setup

- The EUT is set up according to its intended use, as described in the user manual or as defined by the manufacturer.
- Additional equipment, cables, ... necessary for testing, are positioned like under normal operation.
- EUT is powered on and set into operation.
- Test distance depends on EUT size and test antenna size (farfield conditions shall be met).

Pre-scan

- The test antenna is handheld and moved carefully over the EUT to cover the EUT's whole sphere and for different polarizations of the antenna.

Final measurement

- Significant emissions found during the pre-scan will be maximized, i.e. position and antenna orientation causing the highest emissions with Peak and RMS detector
- Final measurement will be performed with measuring equipment settings as defined in the applicable test standards (e.g. ANSI C63.4 / C63.10).
- Final plot showing measurement data, levels, frequency, measuring time, bandwidth, correction factor, margin to the limit and limit is recorded.

Note

- In case of measurements with external harmonic mixers (e.g. above 50 GHz) special care is taken to avoid possible overloading of the external mixer's input.
- As external harmonic mixers may generate false images, care is taken to ensure that any emission measured by the spectrum analyzer is indeed radiated from the EUT and not internally generated by the external harmonic mixer. Signal identification feature of spectrum analyzer is used to eliminate/reduce images of the external harmonic mixer.

Distance correction (extrapolation)

- When performing measurements on test distances other than defined in the rules, the results shall be extrapolated to the specified distance by conservatively presuming that the field strength decays at 20 dB/decade of distance beyond the region λ in m divided by 2π (i.e., $\lambda/2\pi$), using the measurement of a single point at the radial angle that produces the maximum emission.
This correction is already included in the corresponding measurement plots.

Detailed requirements can be found in e.g. ANSI C63.4 / C63.10

10 MEASUREMENT UNCERTAINTIES

Radio frequency	$\leq \pm 1 \times 10^{-7}$
RF power, conducted	$\leq \pm 0.75$ dB
Power spectral density	$\leq \pm 3$ dB
Maximum frequency deviation	$\leq \pm 5$ %
Deviation limitation Duty Cycle, Tx-sequence, Tx-gap	$\leq \pm 5$ %
Occupied channel bandwidth	$\leq \pm 5$ %
Conducted spurious emission of transmitter	$\leq \pm 4$ dB
Conducted emission of receivers	$\leq \pm 4$ dB
Radiated emission of transmitter	$\leq \pm 6$ dB
Radiated emission of receiver	$\leq \pm 6$ dB
Temperature	$\leq \pm 2.5$ °C
Humidity	$\leq \pm 10$ %

The indicated expanded measurement uncertainty corresponds to the standard measurement uncertainty for the measurement results multiplied by the coverage factor $k = 2$. It was determined in accordance with EA-4/02 M:2013. The true value is located in the corresponding interval with a probability of 95 %.