



SCHRADER ELECTRONICS.LTD..
MODEL :AFFPK4

USER MANUAL

The TPMS Transmitter is installed to the valve stem in each tyre of a vehicle. The unit measures tyre pressure periodically and transmits this information by RF communication to a receiver inside the vehicle. In addition, the TPMS Transmitter performs the following functions:

- Determines a temperature compensated pressure value.
- Determines any abnormal pressure variations in the wheel.
- Monitors the state of the Transmitters' internal battery and informs the receiver of a low battery condition.

Fig 1: Sensor block diagram

MODEL :AFFPK4

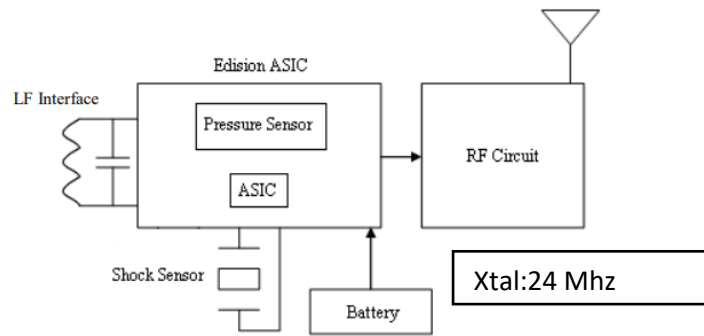
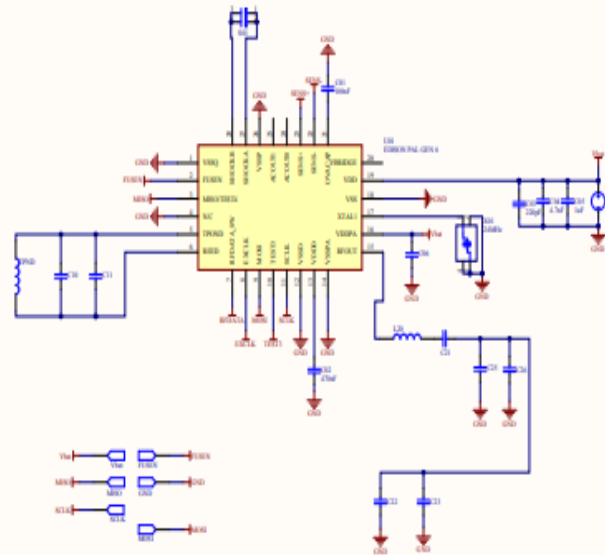

Figure 1 - TPM Sensor Block Diagram

Fig 2: Schematic diagram

MODEL :AFFPK4

Confidential
 Schrader Intellectual Property
 Section:



REV	DESCRIPTION	ECN	DATE	Generic	TITLE	DESIGN	DESIGNER	APPROVED	DATE
01	Initial Release	4674	22/07/11	Faraday/Delta	CIRCUIT SCHEMATIC				22/07/2011
						DRAWING No.90509290		Sheet 1 Of 1	



Modulation

During the Rotating Mode, The modulation used for the sensor is FSK (Frequency Shift Keying) with 50% Manchester bi-phase encoding.

Modes

Rotating Mode

While the sensor/transmitter in the Rotating Mode, it shall satisfy the following requirements. The sensor/transmitter shall transmit an instantaneous measured data, if a pressure change of 2.0 psi from the last transmission or greater has occurred with respect to the following conditions. If the pressure change was a decrease of pressure, the sensor/transmitter shall transmit immediately every time it detects the 2.0-psi or greater pressure changes from the last transmission.

If the pressure change of 2.0 psi or greater was an increase of pressure, the sensor shall not react to it.

Stationary Mode

While the sensor/transmitter in the Stationary Mode, it shall satisfy the following requirements. The sensor/transmitter shall transmit an instantaneous measured data, if a pressure change of 2.0 psi from the last transmission or greater has occurred with respect to the following conditions. If the pressure change was a decrease of pressure, the sensor/transmitter shall transmit immediately every time it detects the 2.0-psi or greater pressure changes from the last transmission.

If the pressure change of 2.0 psi or greater was an increase of pressure, the silent period between the RPC transmission and the last transmission shall be 30.0 seconds, and the silent period between the RPC transmission and the next transmission (Normal scheduled transmission or another RPC transmission) shall also be 30.0 seconds, to be in compliance of FCC Part 15.231.

Factory Mode

The factory mode is the mode that the sensor shall transmit more often in the factory to assure the programmability of the sensor ID during the manufacturing process.

Off Mode

This Off Mode is only for production parts sensors that are used for the builds during the production process and not in the service environment.

LF Initiation

The sensor/transmitter must provide data upon the presence of an LF signal. The sensor must react (Transmit and provide data) no later than 150.0 ms after the LF data code has been detected at the sensor. The sensor/transmitter must be sensitive (As sensitivity is defined in Table 1) and able to detect the LF field.



The device under test is manufactured by the grantee (**Schrader Electronics**) and sold as an OEM product. Per 47 CFR 2.909, 2.927, 2.931, 2.1033, 15.15(b) etc..., the grantee must ensure the end-user has all applicable / appropriate operating instructions. When end-user instructions are required, as in the case of this product, the grantee must notify the OEM to notify the end-user.

Schrader Electronics will supply this document to the reseller/distributor dictating what must be included in the end user's manual for the commercial product.

INFORMATION TO BE INCLUDED IN THE END USER'S MANUAL

The following information (in blue) must be included in the end product user's manual to ensure continued FCC and Industry Canada regulatory compliance. The ID numbers must be included in the manual if the device label is not readily accessible to the end user. The compliance paragraphs below must be included in the user's manual.

FCC ID:MRXAFFPK4

IC: 2546A- AFFPK4

This device complies with Part 15 of the FCC Rules and with Licence exempt RSS standards of Industry Canada. Operation is subject to the following two conditions:

- (1) This device may not cause harmful interference, and
- (2) This device must accept any interference received, including interference that may cause undesired operation.

Any changes or modifications not expressly approved by the party responsible for compliance could void the users authority to operate the equipment.

NOTE: This equipment has been tested and found to comply with the limits for a class B digital device ,pursuant to Part 15 of the FCC Rules. These limits are designed to provide reasonable protection against harmful interference in a residential installation.. This equipment generates ,uses and radiates radio frequency energy and,if not installed and used

in accordance with the instructions ,may cause harmful interference to Radio communications.

However there is no guarantee that interference will not occur in a particular installation.

If this equipment does cause harmful interference to radio or television reception ,which can be determined by turning the equipment off and on ,the user is encouraged to try to correct the interference by one or more of the following measures.

- Reorient or relocate the receiving antenna
- Increase separation between equipment and receiver .
- Connect the equipment into an outlet on a circuit different from that to which the receiver is connected..
- Consult the dealer or an experienced radio/TV technician for help.

Le présent appareil est conforme aux CNR d'Industrie Canada applicables aux appareils radio exempts de licence. L'exploitation est autorisée aux deux conditions suivantes:

- (1) l'appareil ne doit pas produire de brouillage, et
- (2) l'utilisateur de l'appareil doit accepter tout brouillage radio électrique subi, même si le brouillage est susceptible d'en compromettre le fonctionnement.

WARNING: Changes or modifications not expressly approved by the party responsible for compliance could void the user's authority to operate the equipment. The term "IC:" before the radio certification number only signifies that Industry Canada technical specifications were met.
