

FCC Test Report (BT-EDR)

Report No.: RF141112E01A-2 R1

FCC ID: MQT-XCE200WU

Test Model: xCE-200WU-UH

Series Model: xCE-200WU-U

Received Date: Dec. 29, 2014

Test Date: Dec. 29, 2014 to Jan. 27, 2015

Issued Date: Apr. 10, 2015

Applicant: XAC AUTOMATION CORP.

Address: 4F, No. 30, INDUSTRY E. RD. IX, SCIENCE-BASED INDUSTRIAL PARK, HSINCHU, TAIWAN

Issued By: Bureau Veritas Consumer Products Services (H.K.) Ltd., Taoyuan Branch Hsin Chu Laboratory

Lab Address: No. 81-1, Lu Liao Keng, 9th Ling, Wu Lung Tsuen, Chiung Lin Hsiang, Hsin Chu Hsien 307, Taiwan R.O.C.

Test Location (1): No. 81-1, Lu Liao Keng, 9th Ling, Wu Lung Tsuen, Chiung Lin Hsiang, Hsin Chu Hsien 307, Taiwan R.O.C.

Test Location (2): No. 49, Ln. 206, Wende Rd., Shangshan Tsuen, Chiung Lin Hsiang, Hsin Chu Hsien 307, Taiwan R.O.C.



This report is for your exclusive use. Any copying or replication of this report to or for any other person or entity, or use of our name or trademark, is permitted only with our prior written permission. This report sets forth our findings solely with respect to the test samples identified herein. The results set forth in this report are not indicative or representative of the quality or characteristics of the lot from which a test sample was taken or any similar or identical product unless specifically and expressly noted. Our report includes all of the tests requested by you and the results thereof based upon the information that you provided to us. You have 60 days from date of issuance of this report to notify us of any material error or omission caused by our negligence, provided, however, that such notice shall be in writing and shall specifically address the issue you wish to raise. A failure to raise such issue within the prescribed time shall constitute your unqualified acceptance of the completeness of this report, the tests conducted and the correctness of the report contents. Unless specific mention, the uncertainty of measurement has been explicitly taken into account to declare the compliance or non-compliance to the specification. The report must not be used by the client to claim product certification, approval, or endorsement by TAF or any government agencies



Table of Contents

Release Control Record	4
1 Certificate of Conformity	5
2 Summary of Test Results	6
2.1 Measurement Uncertainty.....	6
2.2 Modification Record.....	6
3 General Information	7
3.1 General Description of EUT (Bluetooth).....	7
3.2 Description of Test Modes.....	9
3.2.1 Test Mode Applicability and Tested Channel Detail.....	10
3.3 Description of Support Units.....	12
3.3.1 Configuration of System under Test.....	13
3.4 General Description of Applied Standards.....	14
4 Test Types and Results	15
4.1 Radiated Emission and Bandedge Measurement.....	15
4.1.1 Limits of Radiated Emission and Bandedge Measurement.....	15
4.1.2 Test Instruments.....	16
4.1.3 Test Procedures.....	18
4.1.4 Deviation from Test Standard.....	18
4.1.5 Test Setup.....	19
4.1.6 EUT Operating Conditions.....	19
4.1.7 Test Results.....	20
4.2 Conducted Emission Measurement.....	27
4.2.1 Limits of Conducted Emission Measurement.....	27
4.2.2 Test Instruments.....	27
4.2.3 Test Procedures.....	28
4.2.4 Deviation from Test Standard.....	28
4.2.5 Test Setup.....	28
4.2.6 EUT Operating Condition.....	28
4.2.7 Test Results.....	29
4.3 Number of Hopping Frequency Used Measurement.....	31
4.3.1 Limits of Hopping Frequency Used Measurement.....	31
4.3.2 Test Setup.....	31
4.3.3 Test Instruments.....	31
4.3.4 Test Procedures.....	31
4.3.5 Deviation from Test Standard.....	31
4.3.6 Test Results.....	32
4.4 Dwell Time on Each Channel Measurement.....	33
4.4.1 Limits of Dwell Time on Each Channel Measurement.....	33
4.4.2 Test Setup.....	33
4.4.3 Test Instruments.....	33
4.4.4 Test Procedures.....	33
4.4.5 Deviation from Test Standard.....	33
4.4.6 Test Results.....	34
4.5 Channel Bandwidth Measurement.....	38
4.5.1 Limits of Channel Bandwidth Measurement.....	38
4.5.2 Test Setup.....	38
4.5.3 Test Instruments.....	38
4.5.4 Test Procedures.....	38
4.5.5 Deviation from Test Standard.....	38
4.5.6 EUT Operating Conditions.....	38
4.5.7 Test Results.....	39
4.6 Hopping Channel Separation Measurement.....	40
4.6.1 Limits of Hopping Channel Separation Measurement.....	40



4.6.2	Test Setup.....	40
4.6.3	Test Instruments	40
4.6.4	Test Procedures.....	40
4.6.5	Deviation from Test Standard	40
4.6.6	Test Results	41
4.7	Maximum Output Power Measurement	42
4.7.1	Limits of Maximum Output Power Measurement	42
4.7.2	Test Setup.....	42
4.7.3	Test Instruments	42
4.7.4	Test Procedures.....	42
4.7.5	Deviation from Test Standard	42
4.7.6	EUT Operating Conditions.....	42
4.7.7	Test Results	43
4.8	Conducted Out of Band Emission Measurement.....	44
4.8.1	Limits of Conducted Out Of Band Emission Measurement.....	44
4.8.2	Test Instruments	44
4.8.3	Test Procedures.....	44
4.8.4	Deviation from Test Standard	44
4.8.5	EUT Operating Conditions.....	44
4.8.6	Test Results	44
5	Pictures of Test Arrangements.....	47
	Appendix – Information on the Testing Laboratories	48



A D T

Release Control Record

Issue No.	Description	Date Issued
RF141112E01A-2	Original release.	Feb. 16, 2015
RF141112E01A-2 R1	1. Added the model names. 2. Modified the antenna model name and gain.	Apr. 10, 2015



1 Certificate of Conformity

Product: Terminal

Brand: XAC

Test Model: xCE-200WU-UH

Series Model: xCE-200WU-U

Sample Status: ENGINEERING SAMPLE

Applicant: XAC AUTOMATION CORP.

Test Date: Dec. 29, 2014 to Jan. 27, 2015

Standards: 47 CFR FCC Part 15, Subpart C (Section 15.247)
ANSI C63.10:2009

The above equipment has been tested by **Bureau Veritas Consumer Products Services (H.K.) Ltd., Taoyuan Branch**, and found compliance with the requirement of the above standards. The test record, data evaluation & Equipment Under Test (EUT) configurations represented herein are true and accurate accounts of the measurements of the sample's EMC characteristics under the conditions specified in this report.

Prepared by : Phoenix Huang , **Date:** Apr. 10, 2015
Phoenix Huang / Specialist

Approved by : May Chen , **Date:** Apr. 10, 2015
May Chen / Manager

2 Summary of Test Results

47 CFR FCC Part 15, Subpart C (SECTION 15.247)			
FCC Clause	Test Item	Result	Remarks
15.207	AC Power Conducted Emission	PASS	Meet the requirement of limit. Minimum passing margin is -6.64dB at 0.59620MHz.
15.247(a)(1)(iii)	Number of Hopping Frequency Used	PASS	Meet the requirement of limit.
15.247(a)(1)(iii)	Dwell Time on Each Channel	PASS	Meet the requirement of limit.
15.247(a)(1)	1. Hopping Channel Separation 2. Spectrum Bandwidth of a Frequency Hopping Sequence Spread Spectrum System	PASS	Meet the requirement of limit.
15.247(b)	Maximum Peak Output Power	PASS	Meet the requirement of limit.
15.205 / 15.209 / 15.247(d)	Radiated Emissions and Band Edge Measurement	PASS	Meet the requirement of limit. Minimum passing margin is -0.5dB at 2483.50MHz.
15.247(d)	Antenna Port Emission	PASS	Meet the requirement of limit.
15.203	Antenna Requirement	PASS	No antenna connector is used.

NOTE: If The Frequency Hopping System operating in 2400-2483.5MHz band and the output power less than 125mW. The hopping channel carrier frequencies separated by a minimum of 25kHz or two-thirds of the 20dB bandwidth of hopping channel whichever is greater.

2.1 Measurement Uncertainty

Where relevant, the following measurement uncertainty levels have been estimated for tests performed on the EUT as specified in CISPR 16-4-2:

Measurement	Frequency	Expanded Uncertainty (k=2) (±)
Conducted Emissions at mains ports	150kHz ~ 30MHz	2.86 dB
Radiated Emissions up to 1 GHz	30MHz ~ 1GHz	5.37 dB
Radiated Emissions above 1 GHz	1GHz ~ 6GHz	3.65 dB
	6GHz ~ 18GHz	3.88 dB
	18GHz ~ 40GHz	4.11 dB

2.2 Modification Record

There were no modifications required for compliance.

3 General Information

3.1 General Description of EUT (Bluetooth)

Product	Terminal
Brand	XAC
Test Model	xCE-200WU-UH
Series Model	xCE-200WU-U
Status of EUT	ENGINEERING SAMPLE
Power Supply Rating	12Vdc from power adapter
Modulation Type	GFSK, $\pi/4$ -DQPSK, 8DPSK for FHSS GFSK for DTS
Modulation Technology	FHSS, DTS
Transfer Rate	up to 3Mbps
Operating Frequency	2402MHz ~ 2480MHz
Number of Channel	BT-EDR mode: 79 BT-LE mode: 40
Output Power	BT-EDR mode: 5.689mW BT-LE mode: 5.794mW
Antenna Type	Please see NOTE
Antenna Connector	Please see NOTE
Accessory Device	Adapter x 1 Handset x 1
Data Cable Supplied	NA

Note:

- The EUT has below model names, which are identical to each other in all aspects except for the following table:

Brand Name	Model No.	Description
XAC	xCE-200WU-UH	With 3G (Voice+Data) function and has Handset.
	xCE-200WU-U	With 3G (Data) function.

From the above models, model: **xCE-200WU-UH** was selected as representative model for the test and its data was recorded in this report.

- WLAN, Bluetooth, GSM and WCDMA technology can transmit at same time.
- The EUT could be supplied with a power adapter as the following table:

Brand	Model No.	Spec.
LITEON	PA-1061-71	AC I/P: 100-240V, 50-60Hz, 1.5A AC input cable (Unshielded, 1.8m) DC O/P: 12V, 5A DC output cable(Unshielded, 1.05m, with one core)

4. The antennas provided to the EUT, please refer to the following table:

GSM / WCDMA Antenna Spec.					
Brand	Model No.	Antenna Type	Antenna Connector	Gain(dBi)	Frequency (MHz)
Ethertronics Inc.	T-000084-01	FPCB	NA	0.14	850
				2.57	1900
WLAN / Bluetooth Antenna Spec.					
Brand	Model No.	Antenna Type	Antenna Connector	Gain(dBi)	Frequency (MHz)
ACX	AT8010-E2R9HAA	Chip	NA	2.5	2400-2500

5. When EUT is under LAN mode, the EUT wireless function will be disabled.

6. The above EUT information is declared by manufacturer and for more detailed features description, please refer to the manufacturer's specifications or User's Manual.

3.2 Description of Test Modes

79 channels are provided to this EUT:

Channel	Freq. (MHz)	Channel	Freq. (MHz)	Channel	Freq. (MHz)	Channel	Freq. (MHz)
0	2402	20	2422	40	2442	60	2462
1	2403	21	2423	41	2443	61	2463
2	2404	22	2424	42	2444	62	2464
3	2405	23	2425	43	2445	63	2465
4	2406	24	2426	44	2446	64	2466
5	2407	25	2427	45	2447	65	2467
6	2408	26	2428	46	2448	66	2468
7	2409	27	2429	47	2449	67	2469
8	2410	28	2430	48	2450	68	2470
9	2411	29	2431	49	2451	69	2471
10	2412	30	2432	50	2452	70	2472
11	2413	31	2433	51	2453	71	2473
12	2414	32	2434	52	2454	72	2474
13	2415	33	2435	53	2455	73	2475
14	2416	34	2436	54	2456	74	2476
15	2417	35	2437	55	2457	75	2477
16	2418	36	2438	56	2458	76	2478
17	2419	37	2439	57	2459	77	2479
18	2420	38	2440	58	2460	78	2480
19	2421	39	2441	59	2461		

3.2.1 Test Mode Applicability and Tested Channel Detail

EUT CONFIGURE MODE	APPLICABLE TO				DESCRIPTION
	RE≥1G	RE<1G	PLC	APCM	
-	√	√	√	√	-

Where **RE≥1G**: Radiated Emission above 1GHz **RE<1G**: Radiated Emission below 1GHz
PLC: Power Line Conducted Emission **APCM**: Antenna Port Conducted Measurement

Radiated Emission Test (Above 1GHz):

- Pre-Scan has been conducted to determine the worst-case mode from all possible combinations between available modulations, data rates and antenna ports (if EUT with antenna diversity architecture).
- Following channel(s) was (were) selected for the final test as listed below.

AVAILABLE CHANNEL	TESTED CHANNEL	MODULATION TECHNOLOGY	MODULATION TYPE	PACKET TYPE
0 to 78	0, 39, 78	FHSS	GFSK	DH5
0 to 78	0, 39, 78	FHSS	8DPSK	3DH5

Radiated Emission Test (Below 1GHz):

- Pre-Scan has been conducted to determine the worst-case mode from all possible combinations between available modulations, data rates and antenna ports (if EUT with antenna diversity architecture).
- Following channel(s) was (were) selected for the final test as listed below.

AVAILABLE CHANNEL	TESTED CHANNEL	MODULATION TECHNOLOGY	MODULATION TYPE	PACKET TYPE
0 to 78	0	FHSS	GFSK	DH5

Power Line Conducted Emission Test:

- Pre-Scan has been conducted to determine the worst-case mode from all possible combinations between available modulations, data rates and antenna ports (if EUT with antenna diversity architecture).
- Following channel(s) was (were) selected for the final test as listed below.

AVAILABLE CHANNEL	TESTED CHANNEL	MODULATION TECHNOLOGY	MODULATION TYPE	PACKET TYPE
0 to 78	0	FHSS	GFSK	DH5

Antenna Port Conducted Measurement:

- This item includes all test value of each mode, but only includes spectrum plot of worst value of each mode.
- Pre-Scan has been conducted to determine the worst-case mode from all possible combinations between available modulations, data rates and antenna ports (if EUT with antenna diversity architecture).
- Following channel(s) was (were) selected for the final test as listed below.

AVAILABLE CHANNEL	TESTED CHANNEL	MODULATION TECHNOLOGY	MODULATION TYPE	PACKET TYPE
0 to 78	0, 39, 78	FHSS	GFSK	DH5
0 to 78	0, 39, 78	FHSS	8DPSK	3DH5

Test Condition:

APPLICABLE TO	ENVIRONMENTAL CONDITIONS	INPUT POWER	TESTED BY
RE\geq1G	25deg. C, 71%RH	120Vac, 60Hz	Robert Cheng
RE$<$1G	22deg. C, 68%RH	120Vac, 60Hz	Tim Ho
PLC	24deg. C, 55%RH	120Vac, 60Hz	Wythe Lin
APCM	25deg. C, 60%RH	120Vac, 60Hz	Robert Cheng

3.3 Description of Support Units

The EUT has been tested as an independent unit together with other necessary accessories or support units. The following support units or accessories were used to form a representative test configuration during the tests.

No.	Product	Brand	Model No.	Serial No.	FCC ID	Remark
A	iPod shuffle	Apple	MC749TA/A	CC4DMFKUDF DM	NA	Provided by Lab
B	iPod shuffle	Apple	MD778TA/A	CC4JMA9KF4T 1	NA	Provided by Lab
C	iPod shuffle	Apple	MC749TA/A	CC4DN25WDF DM	NA	Provided by Lab
D	iPod shuffle	Apple	MC749TA/A	CC4DN29UDFD M	NA	Provided by Lab
E	Micro SD Card	Sandisk	2GB	NA	NA	Provided by Lab
F	SIM Card	NA	NA	NA	NA	Provided by Lab
G	Telephone Line Simulator	TELTONE	TLS-5C-01	250-00193-07	NA	Provided by Lab

NOTE:

1. All power cords of the above support units are non-shielded (1.8 m).

No.	Cable	Qty.	Length (m)	Shielded (Yes/ No)	Cores (Number)	Remark
1	DC	1	1.05	No	1	Supplied by Client
2	USB	1	0.1	Yes	0	Provided by Lab
3	RS232	1	1.5	Yes	0	Supplied by Client
4	RJ-45	1	10	No	0	Provided by Lab
5	RJ-11	1	1.5	No	0	Provided by Lab
6	Micro USB	1	1.5	No	0	Provided by Lab
7	RS232	1	1.5	Yes	0	Supplied by Client
8	AC	1	1.8	No	0	Supplied by Client

NOTE:

1. The core(s) is(are) originally attached to the cable(s).

3.3.1 Configuration of System under Test

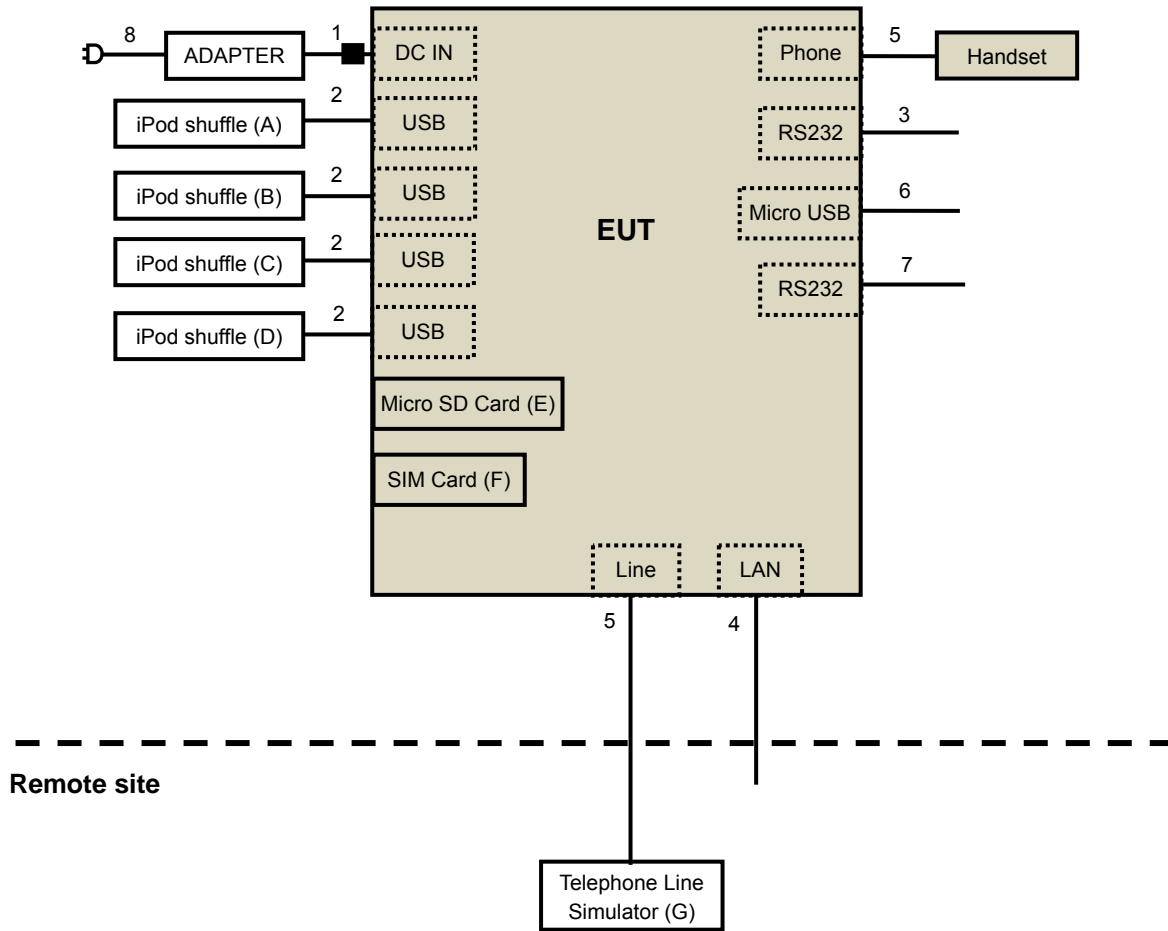

3.4 General Description of Applied Standards

The EUT is a RF Product. According to the specifications of the manufacturer, it must comply with the requirements of the following standards:

FCC Part 15, Subpart C (15.247)

FCC Public Notice DA 00-705

ANSI C63.10-2009

All test items have been performed and recorded as per the above standards.

4 Test Types and Results

4.1 Radiated Emission and Bandedge Measurement

4.1.1 Limits of Radiated Emission and Bandedge Measurement

Radiated emissions which fall in the restricted bands must comply with the radiated emission limits specified as below table. Other emissions shall be at least 20dB below the highest level of the desired power:

Frequencies (MHz)	Field Strength (microvolts/meter)	Measurement Distance (meters)
0.009 ~ 0.490	2400/F(kHz)	300
0.490 ~ 1.705	24000/F(kHz)	30
1.705 ~ 30.0	30	30
30 ~ 88	100	3
88 ~ 216	150	3
216 ~ 960	200	3
Above 960	500	3

NOTE:

1. The lower limit shall apply at the transition frequencies.
2. Emission level (dBuV/m) = 20 log Emission level (uV/m).
3. For frequencies above 1000MHz, the field strength limits are based on average detector, however, the peak field strength of any emission shall not exceed the maximum permitted average limits, specified above by more than 20dB under any condition of modulation.

4.1.2 Test Instruments

For Below 1GHz:

DESCRIPTION & MANUFACTURER	MODEL NO.	SERIAL NO.	CALIBRATED DATE	CALIBRATED UNTIL
MXE EMI Receiver Agilent	N9038A	MY51210105	July 21,2014	July 20,2015
Pre-Amplifier Mini-Circuits	ZFL-1000VH2 B	AMP-ZFL-03	Nov. 12, 2014	Nov. 11, 2015
Trilog Broadband Antenna SCHWARZBECK	VULB 9168	9168-360	Feb. 26, 2014	Feb. 25, 2015
RF Cable	NA	CHGCAB_001	Oct. 04, 2014	Oct. 03, 2015
Horn_Antenna AISI	AIH.8018	0000320091110	Aug. 27, 2014	Aug. 26, 2015
Pre-Amplifier Agilent	8449B	3008A02578	June 24, 2014	June 23, 2015
RF Cable	NA	131205 131214 SNMY23684/4	Jan. 17, 2014	Jan. 16, 2015
Spectrum Analyzer R&S	FSV40	100964	July 05, 2014	July 04, 2015
Pre-Amplifier EMCI	EMC184045	980143	Jan. 17, 2014	Jan. 16, 2015
Horn_Antenna SCHWARZBECK	BBHA 9170	9170-424	Aug. 26, 2014	Aug. 25, 2015
RF Cable	NA	RF104-121 RF104-204	Dec. 11, 2014	Dec. 10, 2015
Antenna Tower & Turn Table CT	NA	NA	NA	NA

Note:

1. The calibration interval of the above test instruments is 12 months and the calibrations are traceable to NML/ROC and NIST/USA.
2. The horn antenna, preamplifier (model: 8449B) are used only for the measurement of emission frequency above 1GHz if tested.
- 3 The test was performed in 966 Chamber No. G.
4. The FCC Site Registration No. is 966073.
- 5 The VCCI Site Registration No. is G-137.
- 6 The CANADA Site Registration No. is IC 7450H-2.
- 7 Tested Date: Dec. 29, 2014

For Above 1GHz:

DESCRIPTION & MANUFACTURER	MODEL NO.	SERIAL NO.	CALIBRATED DATE	CALIBRATED UNTIL
MXE EMI Receiver Agilent	N9038A	MY51210105	July 21, 2014	July 20, 2015
Pre-Amplifier Mini-Circuits	ZFL-1000VH2 B	AMP-ZFL-03	Nov. 12, 2014	Nov. 11, 2015
Trilog Broadband Antenna SCHWARZBECK	VULB 9168	9168-360	Feb. 26, 2014	Feb. 25, 2015
RF Cable	NA	CHGCAB_001	Oct. 04, 2014	Oct. 03, 2015
Horn_Antenna AISI	AIH.8018	0000320091110	Aug. 27, 2014	Aug. 26, 2015
Pre-Amplifier Agilent	8449B	3008A02578	June 24, 2014	June 23, 2015
RF Cable	NA	131205 131214 SNMY23684/4	Jan. 16, 2015	Jan. 15, 2016
Spectrum Analyzer R&S	FSV40	100964	July 05, 2014	July 04, 2015
Pre-Amplifier EMCI	EMC184045	980143	Jan. 15, 2015	Jan. 14, 2016
Horn_Antenna SCHWARZBECK	BBHA 9170	9170-424	Aug. 26, 2014	Aug. 25, 2015
RF Cable	NA	RF104-121 RF104-204	Dec. 11, 2014	Dec. 10, 2015
Antenna Tower & Turn Table CT	NA	NA	NA	NA
SPECTRUM ANALYZER R&S	FSP 40	100060	May 08, 2014	May 07, 2015
Power meter Anritsu	ML2495A	1014008	Apr. 30, 2014	Apr. 29, 2015
Power sensor Anritsu	MA2411B	0917122	Apr. 30, 2014	Apr. 29, 2015
Temperature & Humidity Chamber GIANTFORCE	GTH-150-40-S P-AR	MAA0812-008	Jan. 12, 2015	Jan. 11, 2016

Note:

1. The calibration interval of the above test instruments is 12 months and the calibrations are traceable to NML/ROC and NIST/USA.
2. The horn antenna, preamplifier (model: 8449B) are used only for the measurement of emission frequency above 1GHz if tested.
- 3 The test was performed in 966 Chamber No. G.
4. The FCC Site Registration No. is 966073.
- 5 The VCCI Site Registration No. is G-137.
- 6 The CANADA Site Registration No. is IC 7450H-2.
- 7 Tested Date: Jan. 19, 2015

4.1.3 Test Procedures

- a. The EUT was placed on the top of a rotating table 0.8 meters above the ground at 3 meter chamber room for test. The table was rotated 360 degrees to determine the position of the highest radiation.
- b. The EUT was set 3 meters away from the interference-receiving antenna, which was mounted on the top of a variable-height antenna tower.
- c. The height of antenna is varied from one meter to four meters above the ground to determine the maximum value of the field strength. Both horizontal and vertical polarizations of the antenna are set to make the measurement.
- d. For each suspected emission, the EUT was arranged to its worst case and then the antenna was tuned to heights from 1 meter to 4 meters and the rotatable table was turned from 0 degrees to 360 degrees to find the maximum reading.
- e. The test-receiver system was set to quasi-peak detect function and specified bandwidth with maximum hold mode when the test frequency is below 1 GHz.
- f. The test-receiver system was set to peak detect function and specified bandwidth with maximum hold mode when the test frequency is above 1 GHz.

Note:

1. The resolution bandwidth and video bandwidth of test receiver/spectrum analyzer is 120kHz for Quasi-peak detection (QP) at frequency below 1GHz.
2. The resolution bandwidth of test receiver/spectrum analyzer is 1 MHz and the video bandwidth is 3 MHz for Peak detection (PK) at frequency above 1GHz.
3. For Average measurement, due to the DH5 packet was the worse case duty cycle for a transmit dwell time on a channel, based upon bluetooth theory the transmitter is on $0.625 * 5$ per 296.25 ms per channel. Therefore, the duty cycle correlation factor be equal to: $20\log(3.125 / 100) = -30.1$ dB, therefore Average value = peak reading + $20\log(\text{duty cycle})$.
4. All modes of operation were investigated and the worst-case emissions are reported.

4.1.4 Deviation from Test Standard

No deviation.

4.1.5 Test Setup

<Frequency Range below 1GHz>

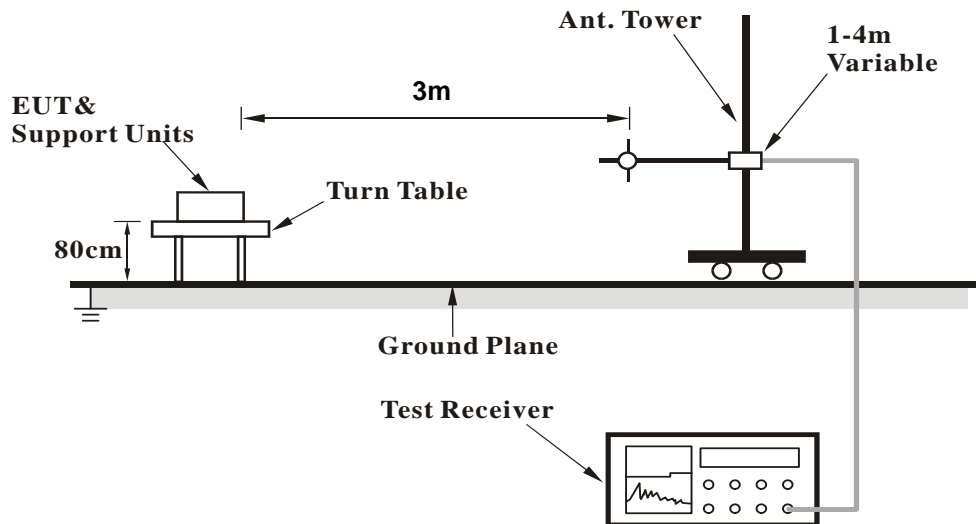

<Frequency Range above 1GHz>

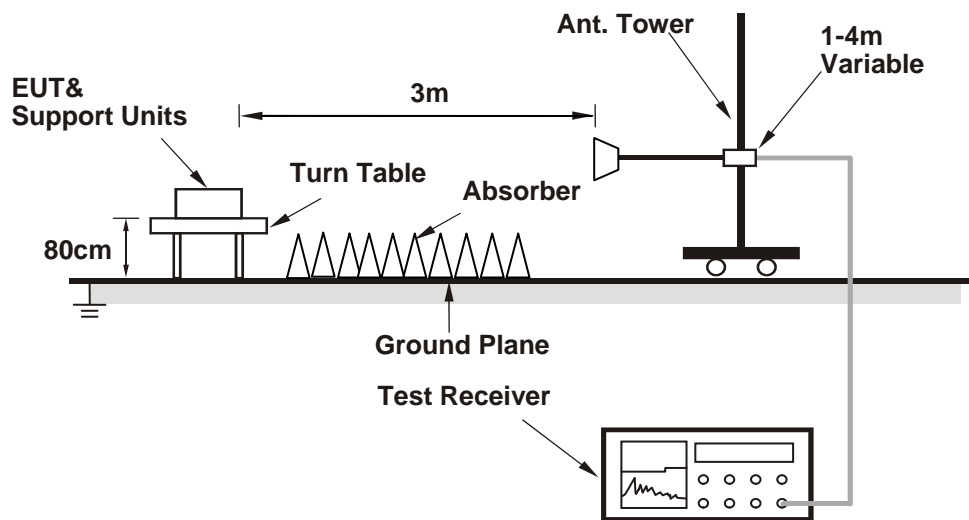

For the actual test configuration, please refer to the attached file (Test Setup Photo).

4.1.6 EUT Operating Conditions

Set the EUT under transmission condition continuously at specific channel frequency.

4.1.7 Test Results
Above 1GHz Data:
BT_GFSK

CHANNEL	TX Channel 0	DETECTOR FUNCTION	Peak (PK)
FREQUENCY RANGE	1GHz ~ 25GHz		

ANTENNA POLARITY & TEST DISTANCE: HORIZONTAL AT 3 M								
NO.	FREQ. (MHz)	EMISSION LEVEL (dBuV/m)	LIMIT (dBuV/m)	MARGIN (dB)	ANTENNA HEIGHT (m)	TABLE ANGLE (Degree)	RAW VALUE (dBuV)	CORRECTION FACTOR (dB/m)
1	2363.60	61.8 PK	74.0	-12.2	1.24 H	141	64.39	-2.59
2	2363.60	31.7 AV	54.0	-22.3	1.24 H	141	34.29	-2.59
3	2390.00	73.3 PK	74.0	-0.7	1.38 H	148	75.77	-2.47
4	2390.00	43.2 AV	54.0	-10.8	1.38 H	148	45.67	-2.47
5	*2402.00	108.8 PK			1.38 H	148	111.21	-2.41
6	*2402.00	78.7 AV			1.38 H	148	81.11	-2.41
7	4804.00	47.8 PK	74.0	-26.2	1.06 H	150	42.18	5.62
8	4804.00	17.7 AV	54.0	-36.3	1.06 H	150	12.08	5.62

ANTENNA POLARITY & TEST DISTANCE: VERTICAL AT 3 M								
NO.	FREQ. (MHz)	EMISSION LEVEL (dBuV/m)	LIMIT (dBuV/m)	MARGIN (dB)	ANTENNA HEIGHT (m)	TABLE ANGLE (Degree)	RAW VALUE (dBuV)	CORRECTION FACTOR (dB/m)
1	2363.60	57.9 PK	74.0	-16.1	1.33 V	238	60.49	-2.59
2	2363.60	27.8 AV	54.0	-26.2	1.33 V	238	30.39	-2.59
3	2390.00	65.9 PK	74.0	-8.1	1.33 V	238	68.37	-2.47
4	2390.00	35.8 AV	54.0	-18.2	1.33 V	238	38.27	-2.47
5	*2402.00	102.8 PK			1.33 V	238	105.21	-2.41
6	*2402.00	72.7 AV			1.33 V	238	75.11	-2.41
7	4804.00	46.4 PK	74.0	-27.6	1.00 V	357	40.78	5.62
8	4804.00	16.3 AV	54.0	-37.7	1.00 V	357	10.68	5.62

REMARKS:

- Emission Level(dBuV/m) = Raw Value(dBuV) + Correction Factor(dB/m)
- Correction Factor(dB/m) = Antenna Factor(dB/m) + Cable Factor(dB) – Pre-Amplifier Factor(dB)
- The other emission levels were very low against the limit.
- Margin value = Emission Level – Limit value
- " * ": Fundamental frequency.
- The DH5 packet was the worse case duty cycle for a transmit dwell time on a channel, based upon bluetooth theory the transmitter is on 0.625 * 5 per 296.25 ms per channel. Therefore, the duty cycle correlation factor be equal to: $20\log(3.125 / 100) = -30.1 \text{ dB}$
- Average value = peak reading + 20log(duty cycle).



CHANNEL	TX Channel 39	DETECTOR FUNCTION	Peak (PK)
FREQUENCY RANGE	1GHz ~ 25GHz		

ANTENNA POLARITY & TEST DISTANCE: HORIZONTAL AT 3 M								
NO.	FREQ. (MHz)	EMISSION LEVEL (dBuV/m)	LIMIT (dBuV/m)	MARGIN (dB)	ANTENNA HEIGHT (m)	TABLE ANGLE (Degree)	RAW VALUE (dBuV)	CORRECTION FACTOR (dB/m)
1	2364.20	64.5 PK	74.0	-9.5	1.24 H	146	67.09	-2.59
2	2364.20	34.4 AV	54.0	-19.6	1.24 H	146	36.99	-2.59
3	2390.00	72.1 PK	74.0	-1.9	1.36 H	144	74.57	-2.47
4	2390.00	42.0 AV	54.0	-12.0	1.36 H	144	44.47	-2.47
5	*2441.00	108.2 PK			1.36 H	144	110.44	-2.24
6	*2441.00	78.1 AV			1.36 H	144	80.34	-2.24
7	2483.50	58.7 PK	74.0	-15.3	1.36 H	144	60.73	-2.03
8	2483.50	28.6 AV	54.0	-25.4	1.36 H	144	30.63	-2.03
9	4882.00	48.6 PK	74.0	-25.4	1.08 H	166	42.66	5.94
10	4882.00	18.5 AV	54.0	-35.5	1.08 H	166	12.56	5.94
11	7323.00	52.4 PK	74.0	-21.6	1.00 H	73	39.22	13.18
12	7323.00	22.3 AV	54.0	-31.7	1.00 H	73	9.12	13.18

ANTENNA POLARITY & TEST DISTANCE: VERTICAL AT 3 M								
NO.	FREQ. (MHz)	EMISSION LEVEL (dBuV/m)	LIMIT (dBuV/m)	MARGIN (dB)	ANTENNA HEIGHT (m)	TABLE ANGLE (Degree)	RAW VALUE (dBuV)	CORRECTION FACTOR (dB/m)
1	2364.20	57.8 PK	74.0	-16.2	1.28 V	223	60.39	-2.59
2	2364.20	27.7 AV	54.0	-26.3	1.28 V	223	30.29	-2.59
3	2390.00	65.9 PK	74.0	-8.1	1.28 V	223	68.37	-2.47
4	2390.00	35.8 AV	54.0	-18.2	1.28 V	223	38.27	-2.47
5	*2441.00	102.8 PK			1.28 V	223	105.04	-2.24
6	*2441.00	72.7 AV			1.28 V	223	74.94	-2.24
7	2483.50	58.0 PK	74.0	-16.0	1.28 V	223	60.03	-2.03
8	2483.50	27.9 AV	54.0	-26.1	1.28 V	223	29.93	-2.03
9	4882.00	45.7 PK	74.0	-28.3	1.01 V	333	39.76	5.94
10	4882.00	15.6 AV	54.0	-38.4	1.01 V	333	9.66	5.94
11	7323.00	54.0 PK	74.0	-20.0	1.00 V	309	40.82	13.18
12	7323.00	23.9 AV	54.0	-30.1	1.00 V	309	10.72	13.18

REMARKS:

- Emission Level(dBuV/m) = Raw Value(dBuV) + Correction Factor(dB/m)
- Correction Factor(dB/m) = Antenna Factor(dB/m) + Cable Factor(dB) – Pre-Amplifier Factor(dB)
- The other emission levels were very low against the limit.
- Margin value = Emission Level – Limit value
- " * ": Fundamental frequency.
- The DH5 packet was the worse case duty cycle for a transmit dwell time on a channel, based upon bluetooth theory the transmitter is on 0.625 * 5 per 296.25 ms per channel. Therefore, the duty cycle correlation factor be equal to: $20\log(3.125 / 100) = -30.1$ dB
- Average value = peak reading + $20\log(\text{duty cycle})$.



A D T

CHANNEL	TX Channel 78	DETECTOR FUNCTION	Peak (PK)
FREQUENCY RANGE	1GHz ~ 25GHz		

ANTENNA POLARITY & TEST DISTANCE: HORIZONTAL AT 3 M

NO.	FREQ. (MHz)	EMISSION LEVEL (dBuV/m)	LIMIT (dBuV/m)	MARGIN (dB)	ANTENNA HEIGHT (m)	TABLE ANGLE (Degree)	RAW VALUE (dBuV)	CORRECTION FACTOR (dB/m)
1	*2480.00	108.6 PK			1.31 H	151	110.66	-2.06
2	*2480.00	78.5 AV			1.31 H	151	80.56	-2.06
3	2483.50	73.5 PK	74.0	-0.5	1.31 H	151	75.53	-2.03
4	2483.50	43.4 AV	54.0	-10.6	1.31 H	151	45.43	-2.03
5	4960.00	48.2 PK	74.0	-25.8	1.05 H	166	41.94	6.26
6	4960.00	18.1 AV	54.0	-35.9	1.05 H	166	11.84	6.26
7	7440.00	53.4 PK	74.0	-20.6	1.06 H	79	40.27	13.13
8	7440.00	23.3 AV	54.0	-30.7	1.06 H	79	10.17	13.13

ANTENNA POLARITY & TEST DISTANCE: VERTICAL AT 3 M

NO.	FREQ. (MHz)	EMISSION LEVEL (dBuV/m)	LIMIT (dBuV/m)	MARGIN (dB)	ANTENNA HEIGHT (m)	TABLE ANGLE (Degree)	RAW VALUE (dBuV)	CORRECTION FACTOR (dB/m)
1	*2480.00	102.9 PK			1.34 V	246	104.96	-2.06
2	*2480.00	72.8 AV			1.34 V	246	74.86	-2.06
3	2483.50	57.7 PK	74.0	-16.3	1.34 V	246	59.73	-2.03
4	2483.50	27.6 AV	54.0	-26.4	1.34 V	246	29.63	-2.03
5	4960.00	45.6 PK	74.0	-28.4	1.02 V	340	39.34	6.26
6	4960.00	15.5 AV	54.0	-38.5	1.02 V	340	9.24	6.26
7	7440.00	52.8 PK	74.0	-21.2	1.06 V	321	39.67	13.13
8	7440.00	22.7 AV	54.0	-31.3	1.06 V	321	9.57	13.13

REMARKS:

- Emission Level(dBuV/m) = Raw Value(dBuV) + Correction Factor(dB/m)
- Correction Factor(dB/m) = Antenna Factor(dB/m) + Cable Factor(dB) – Pre-Amplifier Factor(dB)
- The other emission levels were very low against the limit.
- Margin value = Emission Level – Limit value
- " * " : Fundamental frequency.
- The DH5 packet was the worse case duty cycle for a transmit dwell time on a channel, based upon bluetooth theory the transmitter is on 0.625 * 5 per 296.25 ms per channel. Therefore, the duty cycle correlation factor be equal to: $20\log(3.125 / 100) = -30.1$ dB
- Average value = peak reading + $20\log(\text{duty cycle})$.

BT_8DPSK

CHANNEL	TX Channel 0	DETECTOR FUNCTION	Peak (PK)
FREQUENCY RANGE	1GHz ~ 25GHz		

ANTENNA POLARITY & TEST DISTANCE: HORIZONTAL AT 3 M

NO.	FREQ. (MHz)	EMISSION LEVEL (dBuV/m)	LIMIT (dBuV/m)	MARGIN (dB)	ANTENNA HEIGHT (m)	TABLE ANGLE (Degree)	RAW VALUE (dBuV)	CORRECTION FACTOR (dB/m)
1	2390.00	73.1 PK	74.0	-0.9	1.36 H	147	75.57	-2.47
2	2390.00	43.0 AV	54.0	-11.0	1.36 H	147	45.47	-2.47
3	*2402.00	108.8 PK			1.36 H	147	111.21	-2.41
4	*2402.00	78.7 AV			1.36 H	147	81.11	-2.41
5	4804.00	49.1 PK	74.0	-24.9	1.05 H	169	43.48	5.62
6	4804.00	19.0 AV	54.0	-35.0	1.05 H	169	13.38	5.62

ANTENNA POLARITY & TEST DISTANCE: VERTICAL AT 3 M

NO.	FREQ. (MHz)	EMISSION LEVEL (dBuV/m)	LIMIT (dBuV/m)	MARGIN (dB)	ANTENNA HEIGHT (m)	TABLE ANGLE (Degree)	RAW VALUE (dBuV)	CORRECTION FACTOR (dB/m)
1	2390.00	58.0 PK	74.0	-16.0	1.34 V	246	60.47	-2.47
2	2390.00	27.9 AV	54.0	-26.1	1.34 V	246	30.37	-2.47
3	*2402.00	102.7 PK			1.34 V	246	105.11	-2.41
4	*2402.00	72.6 AV			1.34 V	246	75.01	-2.41
5	4804.00	46.1 PK	74.0	-27.9	1.01 V	360	40.48	5.62
6	4804.00	16.0 AV	54.0	-38.0	1.01 V	360	10.38	5.62

REMARKS:

- Emission Level(dBuV/m) = Raw Value(dBuV) + Correction Factor(dB/m)
- Correction Factor(dB/m) = Antenna Factor(dB/m) + Cable Factor(dB) – Pre-Amplifier Factor(dB)
- The other emission levels were very low against the limit.
- Margin value = Emission Level – Limit value
- " * ": Fundamental frequency.
- The DH5 packet was the worse case duty cycle for a transmit dwell time on a channel, based upon bluetooth theory the transmitter is on 0.625 * 5 per 296.25 ms per channel. Therefore, the duty cycle correlation factor be equal to: $20\log(3.125 / 100) = -30.1$ dB
- Average value = peak reading + $20\log(\text{duty cycle})$.



CHANNEL	TX Channel 39	DETECTOR FUNCTION	Peak (PK)
FREQUENCY RANGE	1GHz ~ 25GHz		

ANTENNA POLARITY & TEST DISTANCE: HORIZONTAL AT 3 M								
NO.	FREQ. (MHz)	EMISSION LEVEL (dBuV/m)	LIMIT (dBuV/m)	MARGIN (dB)	ANTENNA HEIGHT (m)	TABLE ANGLE (Degree)	RAW VALUE (dBuV)	CORRECTION FACTOR (dB/m)
1	*2441.00	108.8 PK			1.41 H	137	111.04	-2.24
2	*2441.00	78.7 AV			1.41 H	137	80.94	-2.24
3	4882.00	48.6 PK	74.0	-25.4	1.02 H	155	42.66	5.94
4	4882.00	18.5 AV	54.0	-35.5	1.02 H	155	12.56	5.94
5	7323.00	52.9 PK	74.0	-21.1	1.07 H	82	39.72	13.18
6	7323.00	22.8 AV	54.0	-31.2	1.07 H	82	9.62	13.18

ANTENNA POLARITY & TEST DISTANCE: VERTICAL AT 3 M								
NO.	FREQ. (MHz)	EMISSION LEVEL (dBuV/m)	LIMIT (dBuV/m)	MARGIN (dB)	ANTENNA HEIGHT (m)	TABLE ANGLE (Degree)	RAW VALUE (dBuV)	CORRECTION FACTOR (dB/m)
1	*2441.00	103.3 PK			1.34 V	246	105.54	-2.24
2	*2441.00	73.2 AV			1.34 V	246	75.44	-2.24
3	4882.00	46.7 PK	74.0	-27.3	1.00 V	333	40.76	5.94
4	4882.00	16.6 AV	54.0	-37.4	1.00 V	333	10.66	5.94
5	7323.00	53.6 PK	74.0	-20.4	1.00 V	305	40.42	13.18
6	7323.00	23.5 AV	54.0	-30.5	1.00 V	305	10.32	13.18

REMARKS:

1. Emission Level(dBuV/m) = Raw Value(dBuV) + Correction Factor(dB/m)
2. Correction Factor(dB/m) = Antenna Factor(dB/m) + Cable Factor(dB) – Pre-Amplifier Factor(dB)
3. The other emission levels were very low against the limit.
4. Margin value = Emission Level – Limit value
5. " * " : Fundamental frequency.
6. The DH5 packet was the worse case duty cycle for a transmit dwell time on a channel, based upon bluetooth theory the transmitter is on 0.625 * 5 per 296.25 ms per channel. Therefore, the duty cycle correlation factor be equal to: $20\log(3.125 / 100) = -30.1$ dB
7. Average value = peak reading + $20\log(\text{duty cycle})$.



A D T

CHANNEL	TX Channel 78	DETECTOR FUNCTION	Peak (PK)
FREQUENCY RANGE	1GHz ~ 25GHz		

ANTENNA POLARITY & TEST DISTANCE: HORIZONTAL AT 3 M

NO.	FREQ. (MHz)	EMISSION LEVEL (dBuV/m)	LIMIT (dBuV/m)	MARGIN (dB)	ANTENNA HEIGHT (m)	TABLE ANGLE (Degree)	RAW VALUE (dBuV)	CORRECTION FACTOR (dB/m)
1	*2480.00	108.8 PK			1.31 H	136	110.86	-2.06
2	*2480.00	78.7 AV			1.31 H	136	80.76	-2.06
3	2483.50	72.7 PK	74.0	-1.3	1.31 H	136	74.73	-2.03
4	2483.50	42.6 AV	54.0	-11.4	1.31 H	136	44.63	-2.03
5	4960.00	47.9 PK	74.0	-26.1	1.07 H	147	41.64	6.26
6	4960.00	17.8 AV	54.0	-36.2	1.07 H	147	11.54	6.26
7	7440.00	52.9 PK	74.0	-21.1	1.00 H	85	39.77	13.13
8	7440.00	22.8 AV	54.0	-31.2	1.00 H	85	9.67	13.13

ANTENNA POLARITY & TEST DISTANCE: VERTICAL AT 3 M

NO.	FREQ. (MHz)	EMISSION LEVEL (dBuV/m)	LIMIT (dBuV/m)	MARGIN (dB)	ANTENNA HEIGHT (m)	TABLE ANGLE (Degree)	RAW VALUE (dBuV)	CORRECTION FACTOR (dB/m)
1	*2480.00	102.3 PK			1.34 V	246	104.36	-2.06
2	*2480.00	72.2 AV			1.34 V	246	74.26	-2.06
3	2483.50	57.9 PK	74.0	-16.1	1.34 V	246	59.93	-2.03
4	2483.50	27.8 AV	54.0	-26.2	1.34 V	246	29.83	-2.03
5	4960.00	46.2 PK	74.0	-27.8	1.03 V	360	39.94	6.26
6	4960.00	16.1 AV	54.0	-37.9	1.03 V	360	9.84	6.26
7	7440.00	53.4 PK	74.0	-20.6	1.00 V	313	40.27	13.13
8	7440.00	23.3 AV	54.0	-30.7	1.00 V	313	10.17	13.13

REMARKS:

1. Emission Level(dBuV/m) = Raw Value(dBuV) + Correction Factor(dB/m)
2. Correction Factor(dB/m) = Antenna Factor(dB/m) + Cable Factor(dB) – Pre-Amplifier Factor(dB)
3. The other emission levels were very low against the limit.
4. Margin value = Emission Level – Limit value
5. " * " : Fundamental frequency.
6. The DH5 packet was the worse case duty cycle for a transmit dwell time on a channel, based upon bluetooth theory the transmitter is on 0.625 * 5 per 296.25 ms per channel. Therefore, the duty cycle correlation factor be equal to: $20\log(3.125 / 100) = -30.1$ dB
7. Average value = peak reading + $20\log(\text{duty cycle})$.

Below 1GHz Data:

CHANNEL	TX Channel 0	DETECTOR FUNCTION	Quasi-Peak (QP)
FREQUENCY RANGE	Below 1GHz		

ANTENNA POLARITY & TEST DISTANCE: HORIZONTAL AT 3 M

NO.	FREQ. (MHz)	EMISSION LEVEL (dBuV/m)	LIMIT (dBuV/m)	MARGIN (dB)	ANTENNA HEIGHT (m)	TABLE ANGLE (Degree)	RAW VALUE (dBuV)	CORRECTION FACTOR (dB/m)
1	62.83	34.4 QP	40.0	-5.6	2.00 H	13	48.48	-14.11
2	101.88	36.6 QP	43.5	-6.9	2.00 H	256	53.70	-17.08
3	214.39	39.1 QP	43.5	-4.4	2.00 H	105	54.93	-15.83
4	250.00	39.7 QP	46.0	-6.3	1.00 H	80	53.59	-13.92
5	479.98	33.5 QP	46.0	-12.5	2.00 H	340	40.58	-7.12
6	875.02	39.2 QP	46.0	-6.9	1.00 H	149	38.84	0.31

ANTENNA POLARITY & TEST DISTANCE: VERTICAL AT 3 M

NO.	FREQ. (MHz)	EMISSION LEVEL (dBuV/m)	LIMIT (dBuV/m)	MARGIN (dB)	ANTENNA HEIGHT (m)	TABLE ANGLE (Degree)	RAW VALUE (dBuV)	CORRECTION FACTOR (dB/m)
1	62.25	38.2 QP	40.0	-1.8	1.00 V	0	52.20	-14.04
2	101.89	40.5 QP	43.5	-3.0	1.50 V	280	57.55	-17.07
3	142.91	35.0 QP	43.5	-8.5	1.00 V	325	48.13	-13.09
4	214.40	38.2 QP	43.5	-5.3	1.00 V	144	54.07	-15.83
5	374.98	34.6 QP	46.0	-11.4	1.00 V	360	44.41	-9.78
6	428.77	31.3 QP	46.0	-14.7	1.50 V	31	39.52	-8.21

REMARKS:

1. Emission Level(dBuV/m) = Raw Value(dBuV) + Correction Factor(dB/m)
2. Correction Factor(dB/m) = Antenna Factor(dB/m) + Cable Factor(dB) – Pre-Amplifier Factor(dB)
3. The other emission levels were very low against the limit.
4. Margin value = Emission Level – Limit value

4.2 Conducted Emission Measurement

4.2.1 Limits of Conducted Emission Measurement

Frequency (MHz)	Conducted Limit (dBuV)	
	Quasi-peak	Average
0.15 - 0.5	66 - 56	56 - 46
0.50 - 5.0	56	46
5.0 - 30.0	60	50

- Note: 1. The lower limit shall apply at the transition frequencies.
 2. The limit decreases in line with the logarithm of the frequency in the range of 0.15 to 0.50MHz.

4.2.2 Test Instruments

DESCRIPTION & MANUFACTURER	MODEL NO.	SERIAL NO.	CALIBRATED DATE	CALIBRATED UNTIL
Test Receiver ROHDE & SCHWARZ	ESCS 30	100375	Apr. 29, 2014	Apr. 28, 2015
Line-Impedance Stabilization Network (for EUT) SCHWARZBECK	NSLK-8127	8127-522	Sep. 15, 2014	Sep. 14, 2015
Line-Impedance Stabilization Network (for Peripheral) ROHDE & SCHWARZ	ENV216	100071	Nov. 10, 2014	Nov. 09, 2015
RF Cable (JYEBAO)	5DFB	COCCAB-001	Mar. 10, 2014	Mar. 09, 2015
50 ohms Terminator	N/A	EMC-03	Sep. 22, 2014	Sep. 21, 2015
50 ohms Terminator	N/A	EMC-02	Sep. 30, 2014	Sep. 29, 2015
Software ADT	BV ADT_Cond_V7.3.7. 3	NA	NA	NA

Note:

1. The calibration interval of the above test instruments is 12 months and the calibrations are traceable to NML/ROC and NIST/USA.
2. The test was performed in Shielded Room No. C.
- 3 The VCCI Con C Registration No. is C-3611.
- 4 Tested Date: Dec. 30, 2014

4.2.3 Test Procedures

- a. The EUT was placed 0.4 meters from the conducting wall of the shielded room with EUT being connected to the power mains through a line impedance stabilization network (LISN). Other support units were connected to the power mains through another LISN. The two LISNs provide 50 ohm/ 50uH of coupling impedance for the measuring instrument.
- b. Both lines of the power mains connected to the EUT were checked for maximum conducted interference.
- c. The frequency range from 150kHz to 30MHz was searched. Emission levels under (Limit - 20dB) was not recorded.

NOTE: The resolution bandwidth and video bandwidth of test receiver is 9kHz for quasi-peak detection (QP) and average detection (AV) at frequency 0.15MHz-30MHz.

4.2.4 Deviation from Test Standard

No deviation.

4.2.5 Test Setup

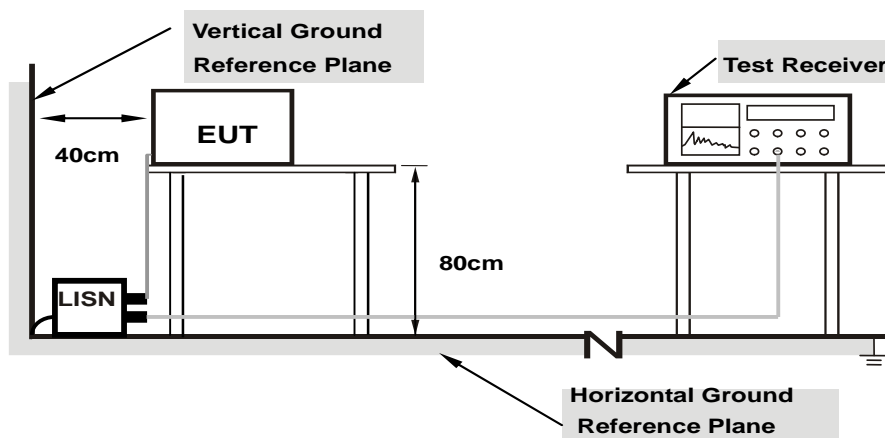

Note: 1.Support units were connected to second LISN.

For the actual test configuration, please refer to the attached file (Test Setup Photo).

4.2.6 EUT Operating Condition

Same as 4.1.6.

4.2.7 Test Results

Phase	Line (L)	Detector Function	Quasi-Peak (QP) / Average (AV)
-------	----------	-------------------	--------------------------------

No	Freq. [MHz]	Corr.	Reading Value		Emission Level		Limit		Margin	
		Factor	[dB (uV)]		[dB (uV)]		[dB (uV)]		(dB)	
	(dB)	Q.P.	AV.	Q.P.	AV.	Q.P.	AV.	Q.P.	AV.	
1	0.15846	0.07	52.89	43.87	52.96	43.94	65.54	55.54	-12.59	-11.61
2	0.21822	0.07	44.97	33.48	45.04	33.55	62.89	52.89	-17.84	-19.33
3	0.59620	0.10	43.20	39.26	43.30	39.36	56.00	46.00	-12.70	-6.64
4	0.86189	0.12	31.70	26.50	31.82	26.62	56.00	46.00	-24.18	-19.38
5	2.11947	0.18	30.71	25.79	30.89	25.97	56.00	46.00	-25.11	-20.03
6	13.89498	0.56	29.03	24.17	29.59	24.73	60.00	50.00	-30.41	-25.27

REMARKS:

1. Q.P. and AV. are abbreviations of quasi-peak and average individually.
2. The emission levels of other frequencies were very low against the limit.
3. Margin value = Emission level – Limit value
4. Correction factor = Insertion loss + Cable loss
5. Emission Level = Correction Factor + Reading Value

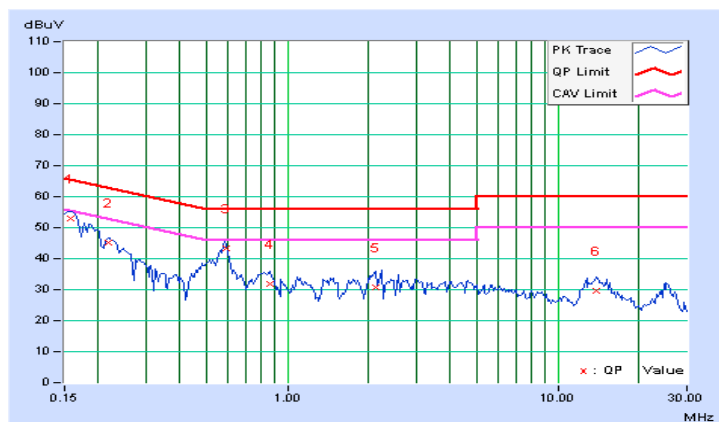

Phase	Neutral (N)	Detector Function	Quasi-Peak (QP) / Average (AV)
-------	-------------	-------------------	--------------------------------

No	Freq. [MHz]	Corr.	Reading Value		Emission Level		Limit		Margin	
		Factor	[dB (uV)]		[dB (uV)]		[dB (uV)]		(dB)	
	(dB)	Q.P.	AV.	Q.P.	AV.	Q.P.	AV.	Q.P.	AV.	
1	0.15101	0.06	53.45	45.01	53.51	45.07	65.94	55.94	-12.43	-10.87
2	0.19348	0.06	47.46	35.17	47.52	35.23	63.89	53.89	-16.37	-18.66
3	0.58410	0.10	42.89	37.08	42.99	37.18	56.00	46.00	-13.01	-8.82
4	0.82460	0.12	30.41	26.47	30.53	26.59	56.00	46.00	-25.47	-19.41
5	2.74746	0.21	30.78	25.03	30.99	25.24	56.00	46.00	-25.01	-20.76
6	14.70413	0.60	30.45	24.70	31.05	25.30	60.00	50.00	-28.95	-24.70

REMARKS:

1. Q.P. and AV. are abbreviations of quasi-peak and average individually.
2. The emission levels of other frequencies were very low against the limit.
3. Margin value = Emission level – Limit value
4. Correction factor = Insertion loss + Cable loss
5. Emission Level = Correction Factor + Reading Value

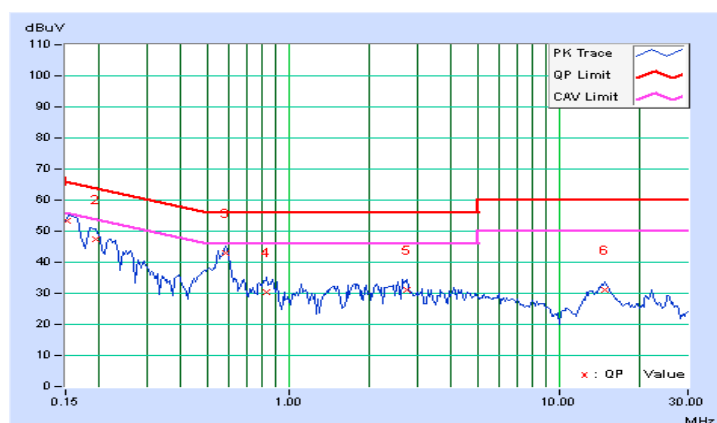

4.3 Number of Hopping Frequency Used Measurement

4.3.1 Limits of Hopping Frequency Used Measurement

At least 15 channels frequencies, and should be equally spaced.

4.3.2 Test Setup

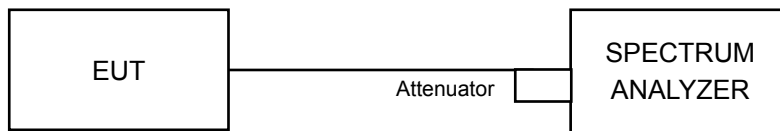

4.3.3 Test Instruments

Refer to section 4.1.2 to get information of above instrument.

4.3.4 Test Procedures

- a. Check the calibration of the measuring instrument (SA) using either an internal calibrator or a known signal from an external generator.
- b. Turn on the EUT and connect its antenna terminal to measurement via a low loss cable. Then set it to any one measured frequency within its operating range and make sure the instrument is operated in its linear range.
- c. Set the SA on MaxHold Mode, and then keep the EUT in hopping mode. Record all the signals from each channel until each one has been recorded.
- d. Set the SA on View mode and then plot the result on SA screen.
- e. Repeat above procedures until all frequencies measured were complete.

4.3.5 Deviation from Test Standard

No deviation.

4.3.6 Test Results

There are 79 hopping frequencies in the hopping mode. Please refer to next page for the test result. On the plots, it shows that the hopping frequencies are equally spaced.

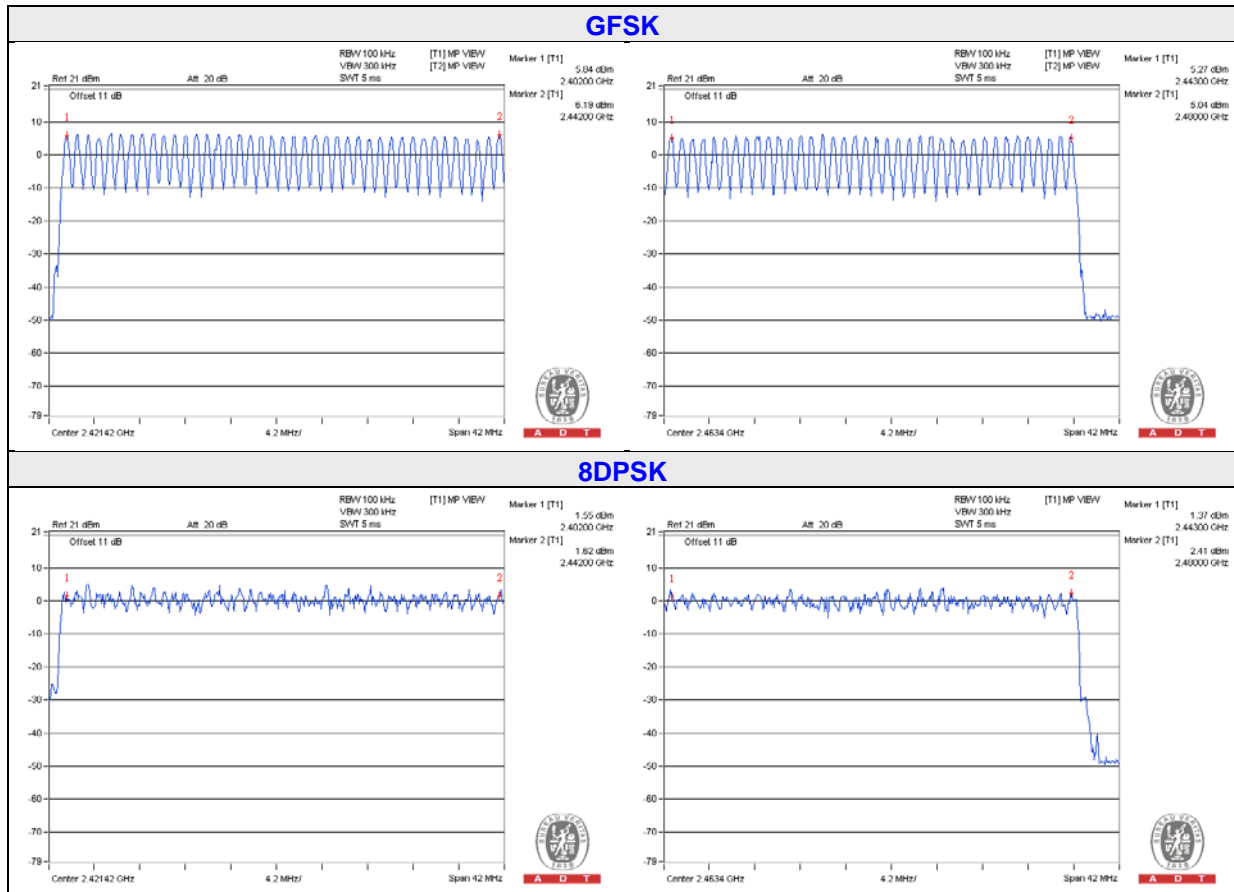

4.4 Dwell Time on Each Channel Measurement

4.4.1 Limits of Dwell Time on Each Channel Measurement

The average time of occupancy on any channel shall not be greater than 0.4 seconds within a period of 0.4 seconds multiplied by the number of hopping channels employed.

4.4.2 Test Setup

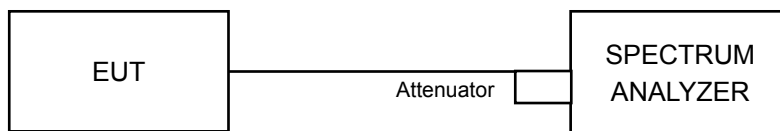

4.4.3 Test Instruments

Refer to section 4.1.2 to get information of above instrument.

4.4.4 Test Procedures

- a. Check the calibration of the measuring instrument (SA) using either an internal calibrator or a known signal from an external generator.
- b. Turn on the EUT and connect its antenna terminal to measurement via a low loss cable. Then set it to any one measured frequency within its operating range and make sure the instrument is operated in its linear range.
- c. Adjust the center frequency of SA on any frequency be measured and set SA to zero span mode. And then, set RBW and VBW of spectrum analyzer to proper value.
- d. Measure the time duration of one transmission on the measured frequency. And then plot the result with time difference of this time duration.
- e. Repeat above procedures until all different time-slot modes have been completed.

4.4.5 Deviation from Test Standard

No deviation.

4.4.6 Test Results

GFSK

Mode	Number of transmission in a 31.6 (79Hopping*0.4)	Length of transmission time (msec)	Result (msec)	Limit (msec)
DH1	50 (times / 5 sec) * 6.32 = 316 times	0.432	136.51	400
DH3	25 (times / 5 sec) * 6.32 = 158 times	1.77	279.66	400
DH5	18 (times / 5 sec) * 6.32 = 113.76 times	2.96	336.73	400

NOTE: Test plots of the transmitting time slot are shown on next page.

DH1

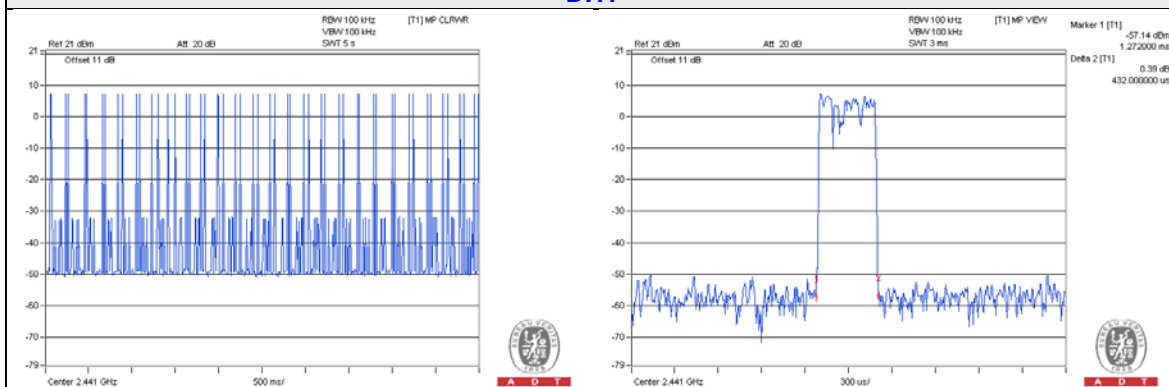

DH3

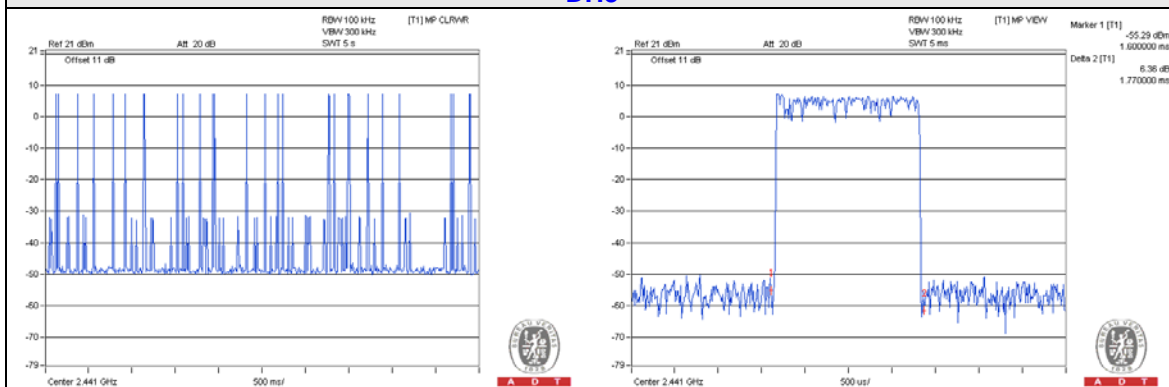

DH5

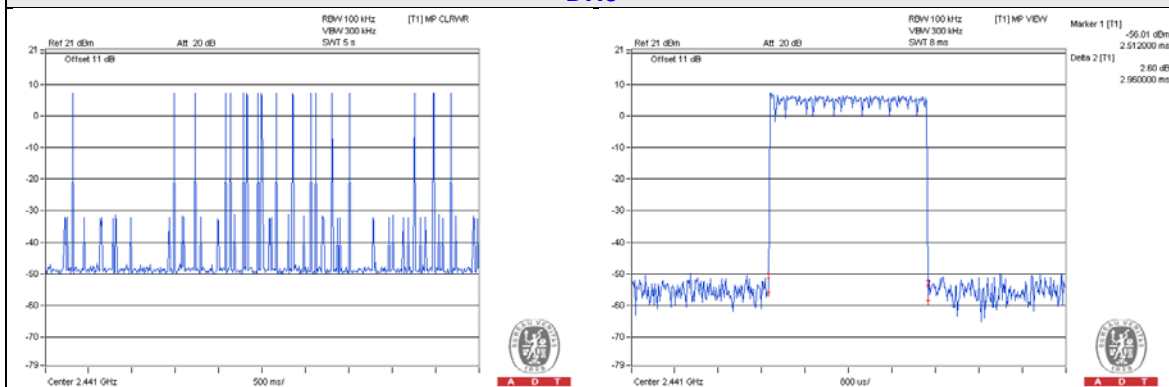

8DPSK

Mode	Number of transmission in a 31.6 (79Hopping*0.4)	Length of transmission time (msec)	Result (msec)	Limit (msec)
3DH1	50 (times / 5 sec) * 6.32 = 316 times	0.456	144.1	400
3DH3	25 (times / 5 sec) * 6.32 = 158 times	1.74	274.92	400
3DH5	18 (times / 5 sec) * 6.32 = 113.76 times	2.992	340.37	400

NOTE: Test plots of the transmitting time slot are shown on next page.

3DH1

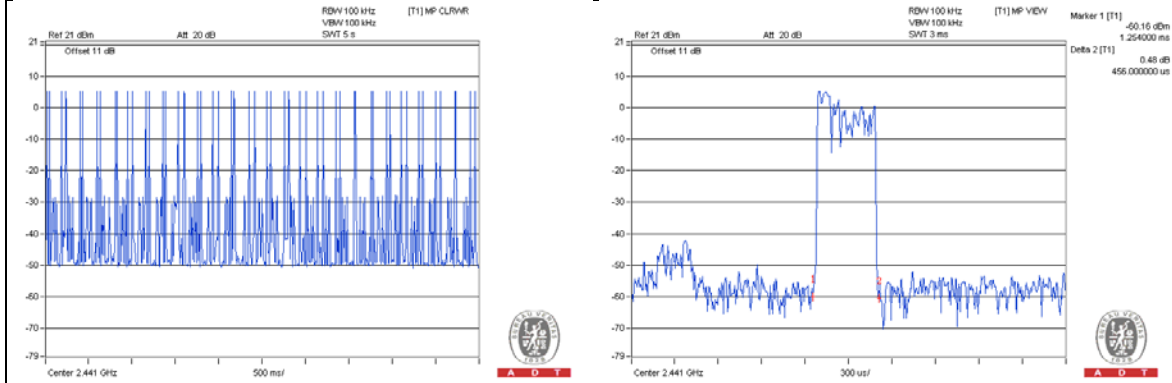

3DH3

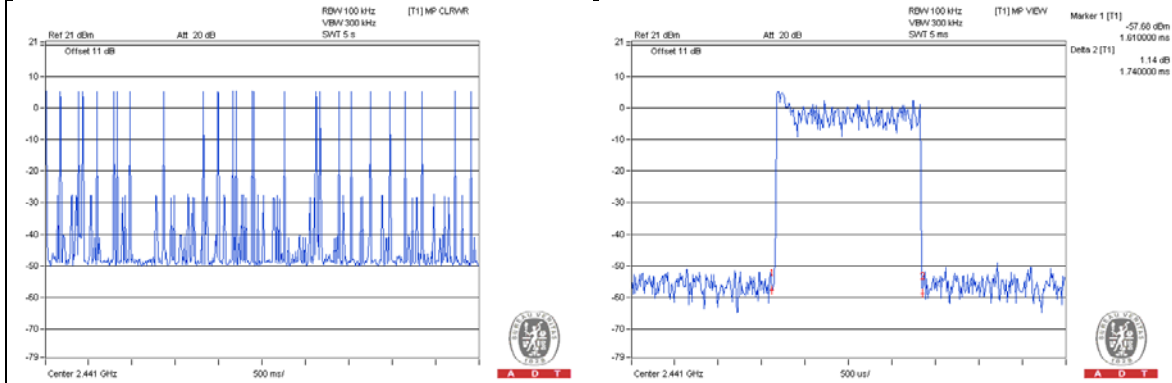

3DH5

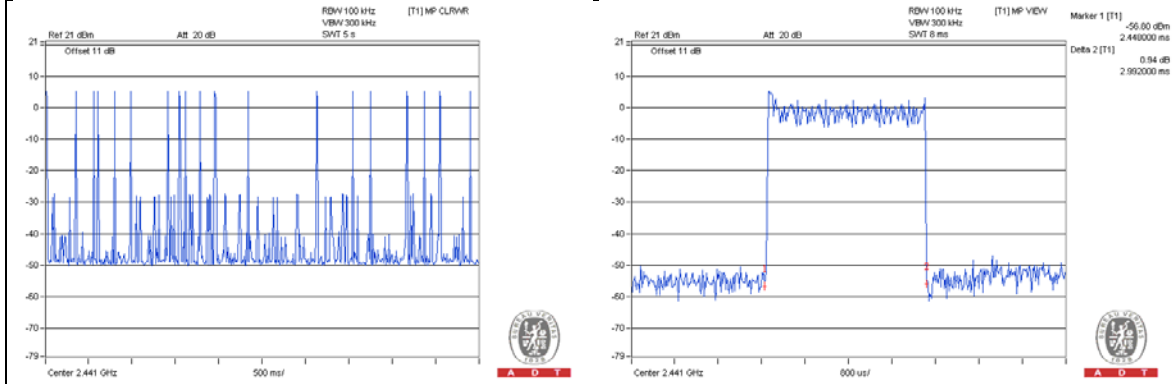

4.5 Channel Bandwidth Measurement

4.5.1 Limits of Channel Bandwidth Measurement

For frequency hopping system operating in the 2400-2483.5MHz, If the 20dB bandwidth of hopping channel is greater than 25kHz, two-thirds 20dB bandwidth of hopping channel shall be a minimum limit for the hopping channel separation.

4.5.2 Test Setup

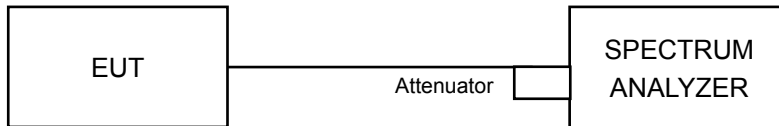

4.5.3 Test Instruments

Refer to section 4.1.2 to get information of above instrument.

4.5.4 Test Procedures

- Check the calibration of the measuring instrument using either an internal calibrator or a known signal from an external generator.
- Turn on the EUT and connect it to measurement instrument. Then set it to any one convenient frequency within its operating range. Set a reference level on the measuring instrument equal to the highest peak value.
- Measure the frequency difference of two frequencies that were attenuated 20dB from the reference level. Record the frequency difference as the emission bandwidth.
- Repeat above procedures until all frequencies measured were complete.

4.5.5 Deviation from Test Standard

No deviation.

4.5.6 EUT Operating Conditions

The software provided by client enabled the EUT to transmit and receive data at lowest, middle and highest channel frequencies individually.

4.5.7 Test Results

Channel	Frequency (MHz)	20dB Bandwidth (MHz)	
		GFSK	8DPSK
0	2402	0.95	1.34
39	2441	0.95	1.34
78	2480	0.95	1.34

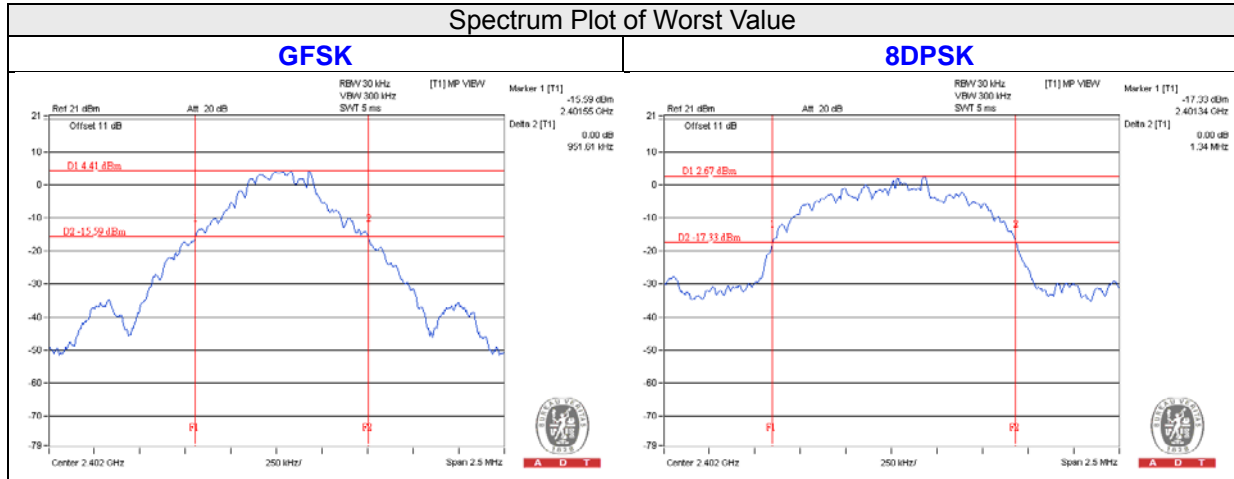

4.6 Hopping Channel Separation Measurement

4.6.1 Limits of Hopping Channel Separation Measurement

At least 25kHz or two-third of 20dB hopping channel bandwidth (whichever is greater).

4.6.2 Test Setup

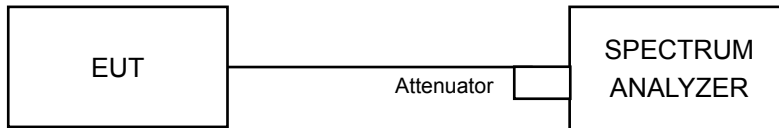

4.6.3 Test Instruments

Refer to section 4.1.2 to get information of above instrument.

4.6.4 Test Procedures

Measurement Procedure REF

- a. Check the calibration of the measuring instrument using either an internal calibrator or a known signal from an external generator.
- b. Turn on the EUT and connect it to measurement instrument. Then set it to any one convenient frequency within its operating range.
- c. By using the MaxHold function record the separation of two adjacent channels.
- d. Measure the frequency difference of these two adjacent channels by SA MARK function. And then plot the result on SA screen.
- e. Repeat above procedures until all frequencies measured were complete.

4.6.5 Deviation from Test Standard

No deviation.

4.6.6 Test Results

Channel	Frequency (MHz)	Adjacent Channel Separation (MHz)		20dB Bandwidth (MHz)		Minimum Limit (MHz)		Pass / Fail
		GFSK	8DPSK	GFSK	8DPSK	GFSK	8DPSK	
0	2402	1.01	1.00	0.95	1.34	0.64	0.90	PASS
39	2441	1.01	1.01	0.95	1.34	0.64	0.90	PASS
78	2480	1.00	1.01	0.95	1.34	0.64	0.90	PASS

NOTE: The minimum limit is two-third 20dB bandwidth.

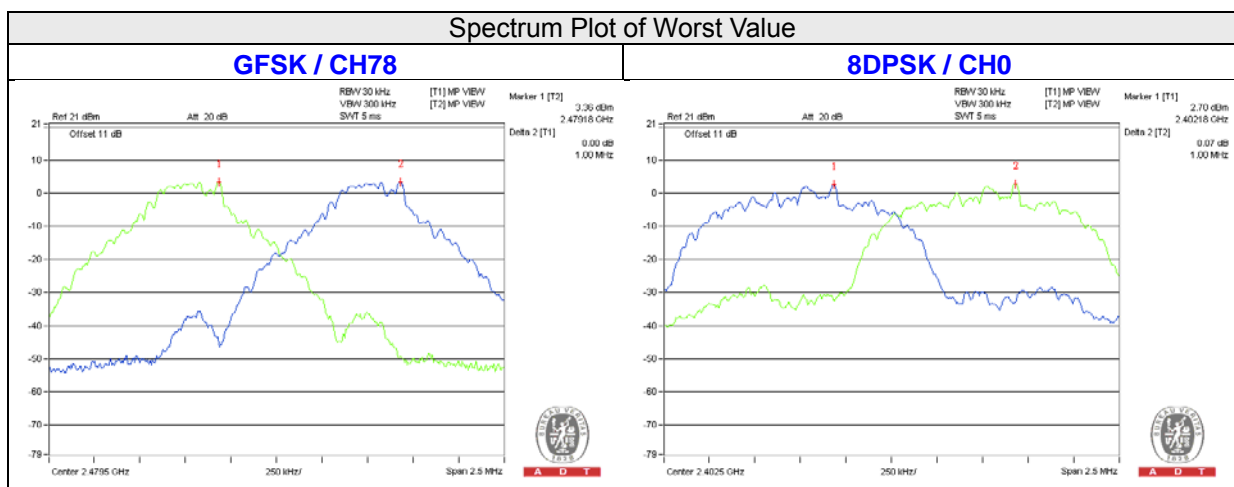

4.7 Maximum Output Power Measurement

4.7.1 Limits of Maximum Output Power Measurement

The Maximum Output Power Measurement is 125mW.

4.7.2 Test Setup

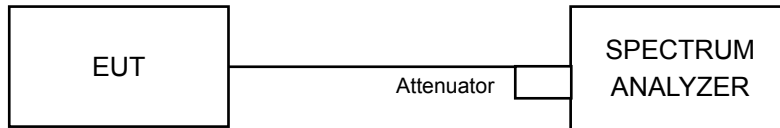

4.7.3 Test Instruments

Refer to section 4.1.2 to get information of above instrument.

4.7.4 Test Procedures

- a. Check the calibration of the measuring instrument using either an internal calibrator or a known signal from an external generator.
- b. Turn on the EUT and connect it to measurement instrument. Then set it to any one convenient frequency within its operating range. Set a reference level on the measuring instrument equal to the highest peak value.
- c. The center frequency of the spectrum analyzer is set to the fundamental frequency and using 3MHz RBW and 10 MHz VBW.
- d. Measure the captured power within the band and recording the plot.
- e. Repeat above procedures until all frequencies required were complete.

4.7.5 Deviation from Test Standard

No deviation.

4.7.6 EUT Operating Conditions

The software provided by client enabled the EUT to transmit and receive data at lowest, middle and highest channel frequencies individually.

4.7.7 Test Results

Channel	Frequency (MHz)	Output Power (mW)		Output Power (dBm)		Power Limit (mW)	Pass/Fail
		GFSK	8DPSK	GFSK	8DPSK		
0	2402	5.689	5.212	7.55	7.17	125	PASS
39	2441	5.023	4.529	7.01	6.56	125	PASS
78	2480	4.656	4.227	6.68	6.26	125	PASS

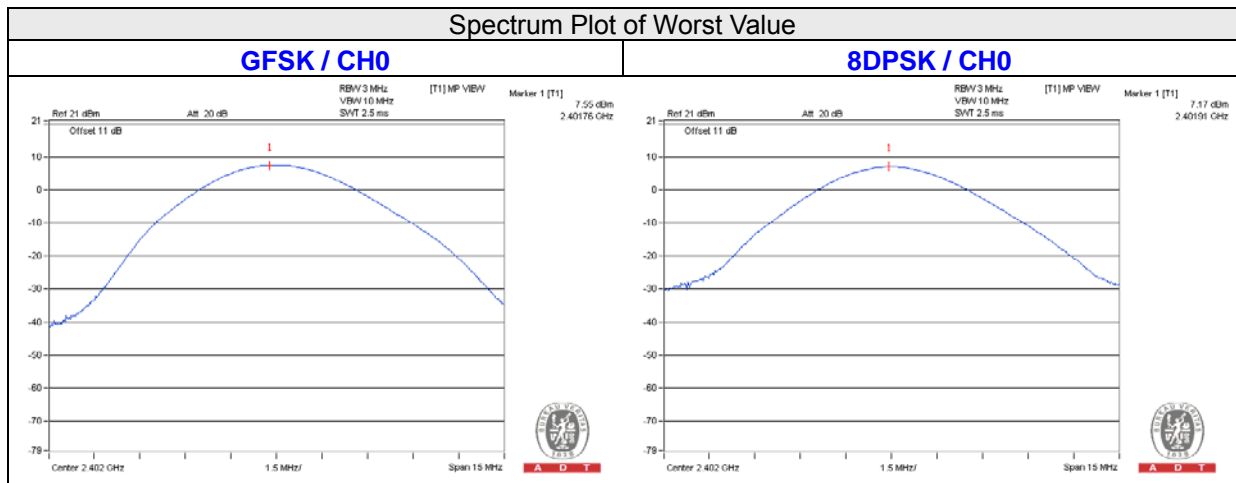

4.8 Conducted Out of Band Emission Measurement

4.8.1 Limits of Conducted Out Of Band Emission Measurement

Below 20dB of the highest emission level of operating band (in 100kHz RBW).

4.8.2 Test Instruments

Refer to section 4.1.2 to get information of above instrument.

4.8.3 Test Procedures

The transmitter output was connected to the spectrum analyzer via a low lose cable. Set both RBW and VBW of spectrum analyzer to 100 kHz and 300 kHz with suitable frequency span including 100 MHz bandwidth from band edge. The band edges was measured and recorded.

4.8.4 Deviation from Test Standard

No deviation.

4.8.5 EUT Operating Conditions

The software provided by client enabled the EUT to transmit and receive data at lowest, middle and highest channel frequencies individually.

4.8.6 Test Results

The spectrum plots are attached on the following images. D1 line indicates the highest level, D2 line indicates the 20dB offset below D1. It shows compliance with the requirement.

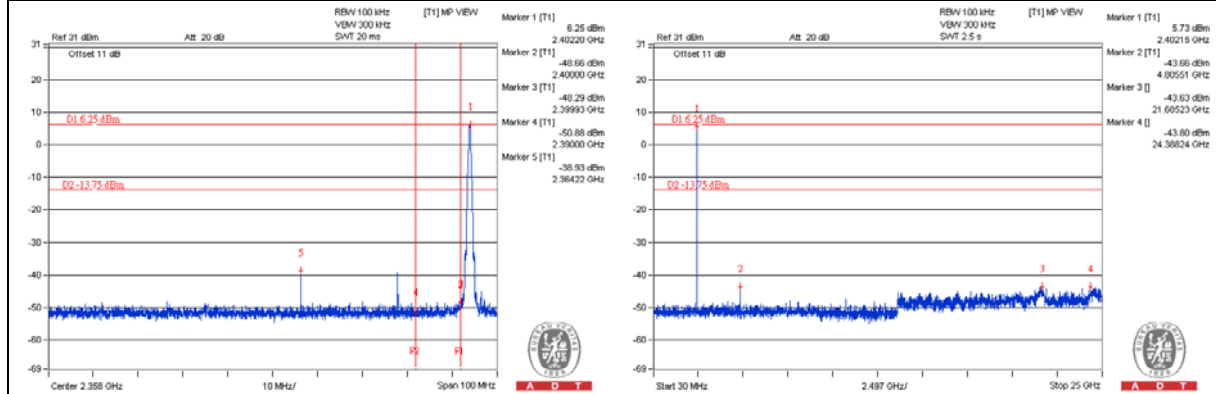
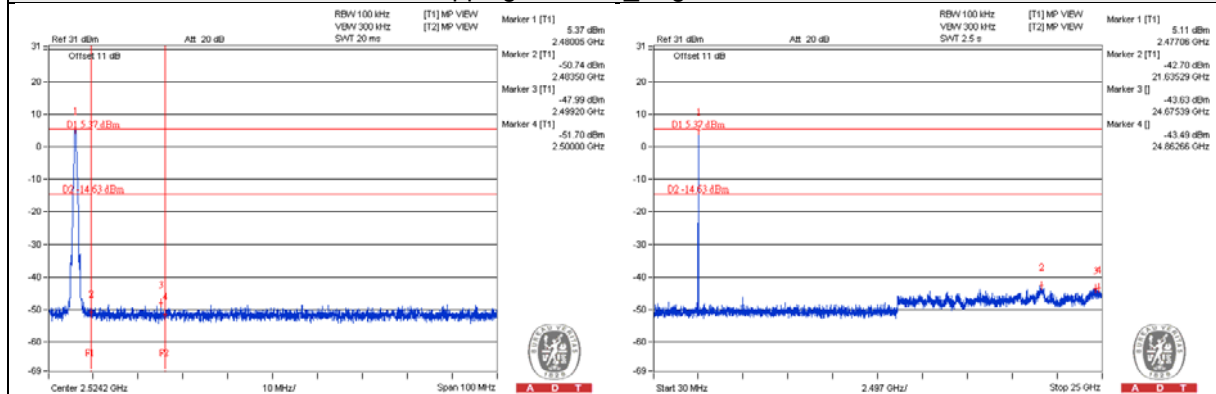
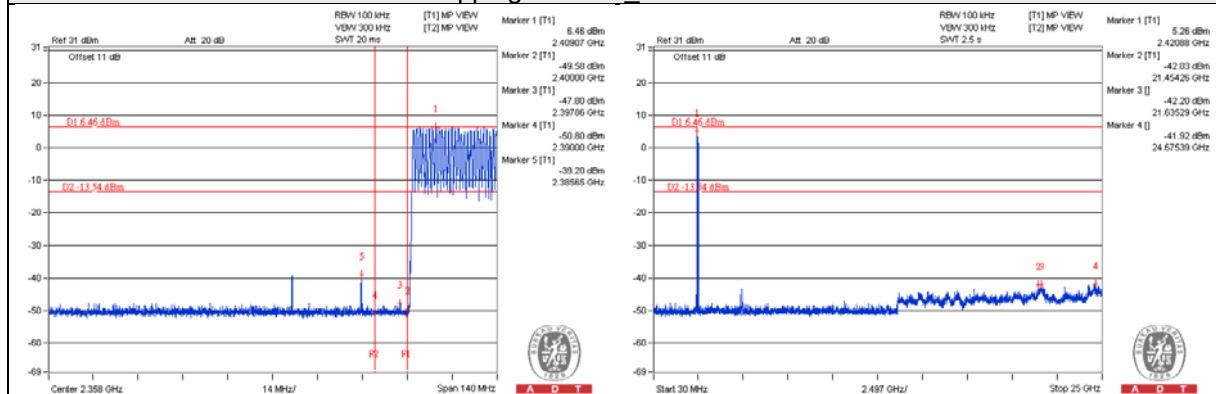
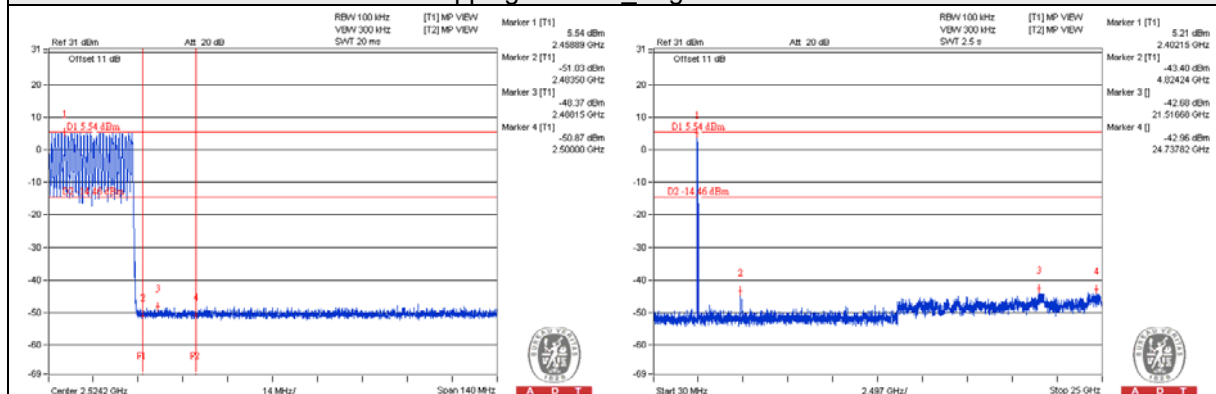
GFSK
Hopping disabled Low Channel

Hopping disabled High Channel

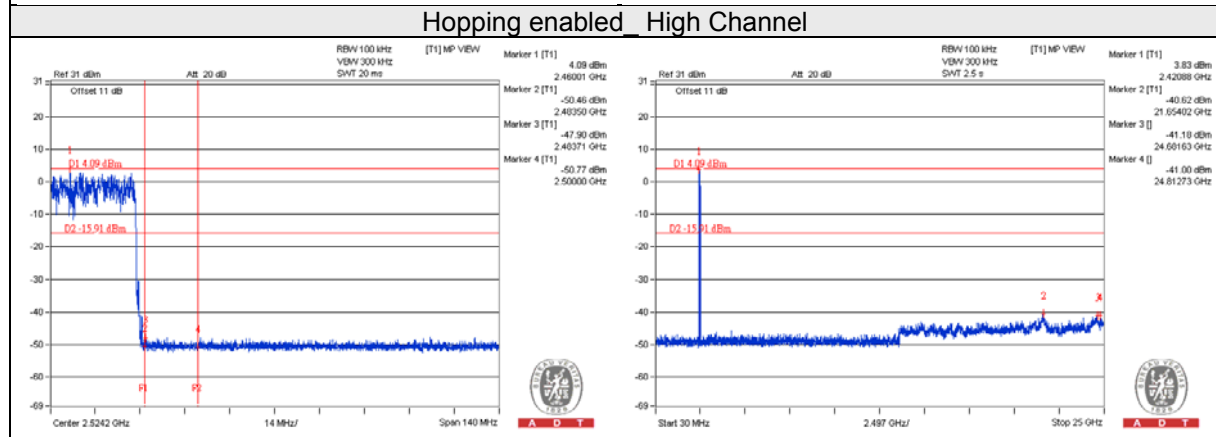
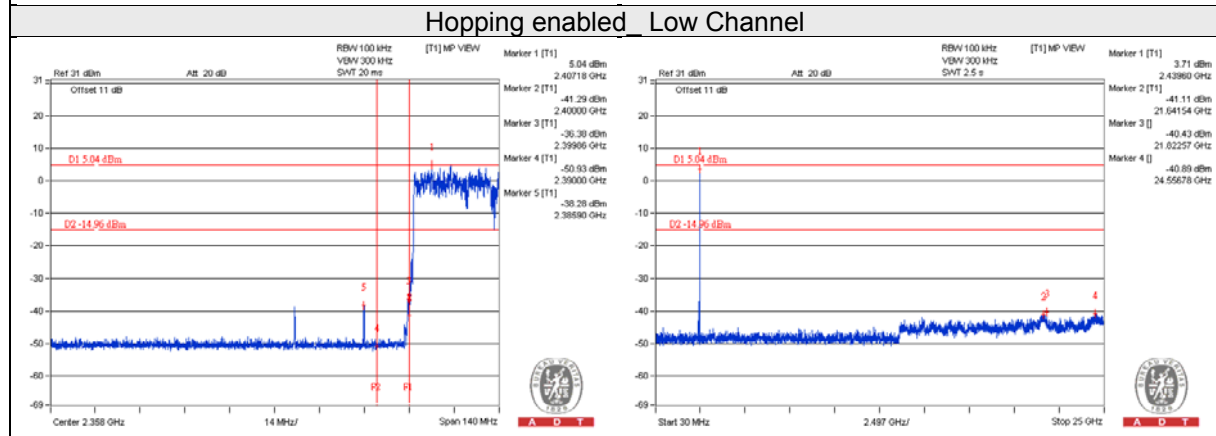
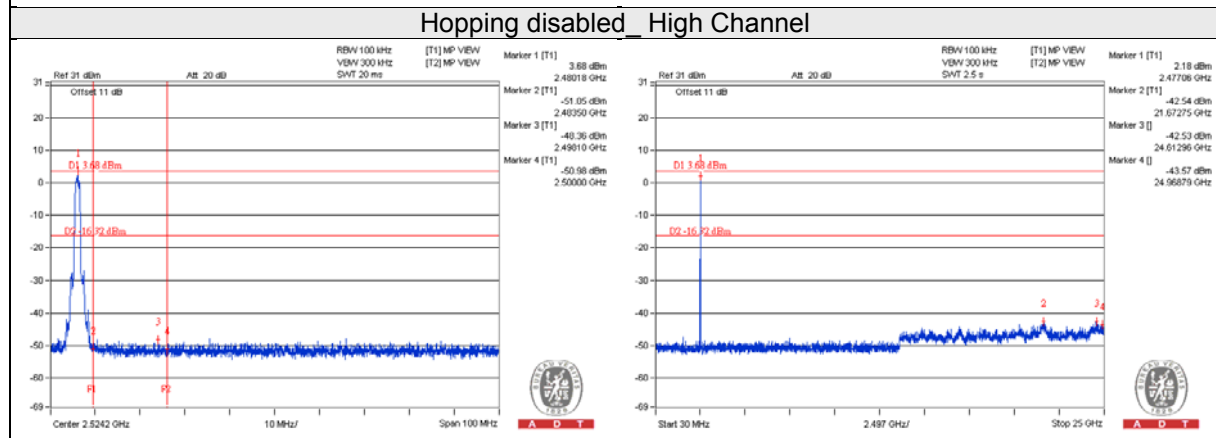
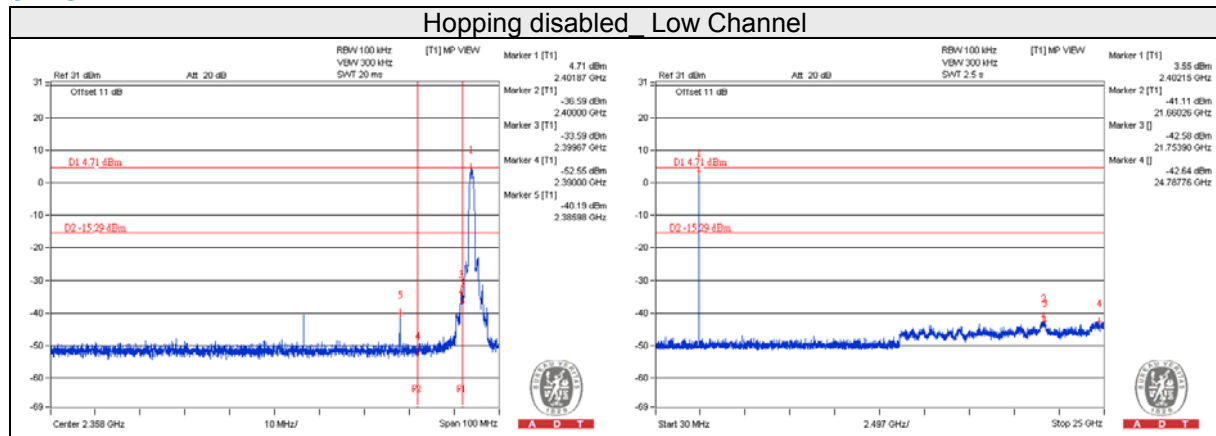
Hopping enabled Low Channel

Hopping enabled High Channel

8DPSK





5 Pictures of Test Arrangements

Please refer to the attached file (Test Setup Photo).



A D T

Appendix – Information on the Testing Laboratories

We, Bureau Veritas Consumer Products Services (H.K.) Ltd., Taoyuan Branch, were founded in 1988 to provide our best service in EMC, Radio, Telecom and Safety consultation. Our laboratories are accredited and approved according to ISO/IEC 17025.

If you have any comments, please feel free to contact us at the following:

Linko EMC/RF Lab

Tel: 886-2-26052180

Fax: 886-2-26051924

Hsin Chu EMC/RF Lab/Telecom Lab

Tel: 886-3-5935343

Fax: 886-3-5935342

Hwa Ya EMC/RF/Safety

Tel: 886-3-3183232

Fax: 886-3-3270892

Email: service.adt@tw.bureauveritas.com

Web Site: www.bureauveritas-adt.com

The address and road map of all our labs can be found in our web site also.

--- END ---