



A D T

FCC TEST REPORT (RFID)

REPORT NO.: RF131029E03-1

MODEL NO.: xAPT-103WiFi.3G

FCC ID: MQT-XAPT103WIFI3G

RECEIVED: Dec. 14, 2012

TESTED: Dec. 14, 2012 to Jan. 08, 2013 and Oct. 30, 2013

ISSUED: Nov. 29, 2013

APPLICANT: XAC AUTOMATION CORP.

ADDRESS: 4F, No. 30, INDUSTRY E. RD. IX, SCIENCE-BASED INDUSTRIAL PARK,HSINCHU,TAIWAN

ISSUED BY: Bureau Veritas Consumer Products Services (H.K.) Ltd., Taoyuan Branch Hsin Chu Laboratory

LAB ADDRESS : No. 81-1, Lu Liao Keng, 9th Ling,Wu Lung Tsuen, Chiung Lin Hsiang, Hsin Chu Hsien 307, Taiwan, R.O.C.

TEST LOCATION (1): No. 81-1, Lu Liao Keng, 9th Ling,Wu Lung Tsuen, Chiung Lin Hsiang, Hsin Chu Hsien 307, Taiwan, R.O.C.

TEST LOCATION (2): No. 49, Ln. 206, Wende Rd., Shangshan Tsuen, Chiung Lin Hsiang, Hsin Chu Hsien 307, Taiwan, R.O.C.

This report should not be used by the client to claim product certification, approval, or endorsement by TAF or any government agencies.



This report is for your exclusive use. Any copying or replication of this report to or for any other person or entity, or use of our name or trademark, is permitted only with our prior written permission. This report sets forth our findings solely with respect to the test samples identified herein. The results set forth in this report are not indicative or representative of the quality or characteristics of the lot from which a test sample was taken or any similar or identical product unless specifically and expressly noted. Our report includes all of the tests requested by you and the results thereof based upon the information that you provided to us. You have 60 days from date of issuance of this report to notify us of any material error or omission caused by our negligence, provided, however, that such notice shall be in writing and shall specifically address the issue you wish to raise. A failure to raise such issue within the prescribed time shall constitute your unqualified acceptance of the completeness of this report, the tests conducted and the correctness of the report contents. Unless specific mention, the uncertainty of measurement has been explicitly taken into account to declare the compliance or non-compliance to the specification



Table of Contents

RELEASE CONTROL RECORD	3
1 CERTIFICATION.....	4
2 SUMMARY OF TEST RESULTS	5
2.1 MEASUREMENT UNCERTAINTY	6
3 GENERAL INFORMATION	7
3.1 GENERAL DESCRIPTION OF EUT	7
3.2 DESCRIPTION OF TEST MODES	9
3.2.1 TEST MODE APPLICABILITY AND TESTED CHANNEL DETAIL.....	10
3.3 GENERAL DESCRIPTION OF APPLIED STANDARDS.....	12
3.4 DESCRIPTION OF SUPPORT UNITS	13
3.5 CONFIGURATION OF SYSTEM UNDER TEST.....	14
4 TEST PROCEDURES AND RESULTS.....	15
4.1 CONDUCTED EMISSION MEASUREMENT.....	15
4.1.1 LIMITS OF CONDUCTED EMISSION MEASUREMENT	15
4.1.2 TEST INSTRUMENTS.....	15
4.1.3 TEST PROCEDURES	16
4.1.4 DEVIATION FROM TEST STANDARD.....	16
4.1.5 TEST SETUP.....	16
4.1.6 EUT OPERATING CONDITIONS	17
4.1.7 TEST RESULTS	18
4.2 RADIATED EMISSION & OCCUPIED BANDWIDTH MEASUREMENT	20
4.2.1 LIMITS OF RADIATED EMISSION MEASUREMENT	20
4.2.2 TEST INSTRUMENTS.....	21
4.2.3 TEST PROCEDURES	23
4.2.4 DEVIATION FROM TEST STANDARD.....	24
4.2.5 TEST SETUP.....	24
4.2.6 EUT OPERATING CONDITIONS	25
4.2.7 TEST RESULTS	26
4.3 20DB BANDWIDTH	30
4.3.1 LIMITS OF 20DB BANDWIDTH MEASUREMENT	30
4.3.2 TEST INSTRUMENTS.....	30
4.3.3 EUT OPERATING CONDITION.....	30
4.3.4 TEST RESULTS	31
4.4 FREQUENCY STABILITY.....	32
4.4.1 LIMITS OF FREQUENCY STABILITY MEASUREMENT	32
4.4.2 TEST INSTRUMENTS.....	32
4.4.3 TEST PROCEDURE.....	32
4.4.4 DEVIATION FROM TEST STANDARD.....	33
4.4.5 TEST SETUP.....	33
4.4.6 EUT OPERATING CONDITION.....	33
4.4.7 TEST RESULTS	34
5 INFORMATION ON THE TESTING LABORATORIES.....	35
6 APPENDIX-A- MODIFICATIONS RECORDERS FOR ENGINEERING CHANGES TO THE EUT BY THE LAB	36



A D T

RELEASE CONTROL RECORD

ISSUE NO.	REASON FOR CHANGE	DATE ISSUED
RF131029E03-1	Original release	Nov. 29, 2013



A D T

1 CERTIFICATION

PRODUCT : Terminal
BRAND NAME : XAC
MODEL NO. : xAPT-103WiFi.3G
TEST SAMPLE : ENGINEERING SAMPLE
APPLICANT : XAC AUTOMATION CORP.
TESTED : Dec. 14, 2012 to Jan. 08, 2013 and Oct. 30, 2013
STANDARDS: FCC Part 15, Subpart C (Section 15.225)
FCC Part 15, Subpart C (Section 15.215)
ANSI C63.10-2009

The above equipment (Model: xAPT-103WiFi.3G) has been tested by **Bureau Veritas Consumer Products Services (H.K.) Ltd., Taoyuan Branch**, and found compliance with the requirement of the above standards. The test record, data evaluation & Equipment Under Test (EUT) configurations represented herein are true and accurate accounts of the measurements of the sample's EMC characteristics under the conditions specified in this report.

PREPARED BY : Phoenix Huang , **DATE:** Nov. 29, 2013
(Phoenix Huang, Specialist)

APPROVED BY : May Chen , **DATE:** Nov. 29, 2013
(May Chen, Manager)



2 SUMMARY OF TEST RESULTS

The EUT has been tested according to the following specifications:

APPLIED STANDARD: FCC PART 15, SUBPART C (SECTION 15.225, 15.215)			
STANDARD SECTION	TEST TYPE AND LIMIT	RESULT	REMARK
15.207	Conducted emission test	PASS	Meet the requirement of limit. Minimum passing margin is -12.21dB at 0.16562MHz.
15.225 (a)	The field strength of any emissions within the band 13.553-13.567 MHz	PASS	Meet the requirement of limit. Minimum passing margin is -41.96dB at 13.56MHz
15.225 (d)	The field strength of any emissions appearing outside of the 13.110-14.010 MHz band	PASS	Meet the requirement of limit. Minimum passing margin is -0.8dB at 75.20MHz
15.225 (e)	The frequency tolerance	PASS	Meet the requirement of limit.
15.215 (c)	20dB Bandwidth	PASS	Meet the requirement of limit.

2.1 MEASUREMENT UNCERTAINTY

Where relevant, the following measurement uncertainty levels have been estimated for tests performed on the EUT as specified in CISPR 16-4-2:

This uncertainty represents an expanded uncertainty expressed at approximately the 95% confidence level using a coverage factor of $k=2$.

Measurement	Value
Conducted Emission	2.98 dB
Radiated emissions-Chamber F	4.00 dB
Radiated emissions-Chamber H	5.46 dB

3 GENERAL INFORMATION

3.1 GENERAL DESCRIPTION OF EUT

PRODUCT	Terminal
MODEL NO.	xAPT-103WiFi.3G
POWER SUPPLY	DC 12V from power adapter
MODULATION TYPE	ASK
OPERATING FREQUENCY	13.56MHz
NUMBER OF CHANNEL	1
ANTENNA TYPE	Please see NOTE
DATA CABLE	NA
I/O PORTS	Refer to user's manual
ASSOCIATED DEVICES	Adapter x 1

NOTE:

1. The EUT is a WLAN, RFID, GSM and WCDMA device.
2. WLAN, RFID, GSM and WCDMA technology cannot transmit at same time.
3. The EUT could be supplied with a power adapter as the following table:

Brand	Model No.	Spec.
HON-KWANG	HK-AX-120A200-US	AC I/P: 100-240V, 50/60Hz, 0.8A DC O/P: 12V, 2A DC output cable(Unshielded, 1.5m)

4. The antennas provided to the EUT, please refer to the following table:

RFID Antenna Spec.						
Brand	Model No.	Antenna Type	Antenna Connector	Gain(dBi)	Frequency (MHz)	
XAC	PCB ENIG ANT BOARD (W/KEY) 8006(ROHS)	PCB (2 Layer)	NA	13	13.56	
GPRS / WCDMA(UMTS) / HSDPA / EDGE Antenna Spec.						
Brand	Model No.	Antenna Type	Antenna Connector	Gain(dBi)	Frequency (MHz)	
Ethertronics Inc.	T-000084-01	FPCB	NA	0.14	850	
				2.57	1900	
WLAN Antenna Spec.						
Transmitter Circuit	Brand	Model No.	Antenna Type	Antenna Connector	Gain(dBi)	Frequency (MHz)
Chain (0)	HUN-PAI	M30-005+-000	PIFA	NA	1.5	2400-2500
Chain (1)					2.9	
NOTE: 1. Chain (0) -- Tx & RX / Chain (1) -- TX						

5. For more detailed product features, please refer to manufacturer's specification or user's manual.

3.2 DESCRIPTION OF TEST MODES

The EUT only has 1 channel.

CHANNEL	FREQUENCY (MHz)
1	13.56

3.2.1 TEST MODE APPLICABILITY AND TESTED CHANNEL DETAIL

4

EUT CONFIGURE MODE	APPLICABLE TO					DESCRIPTION
	PLC	RE (Below 30MHz)	RE (Above 30MHz)	FS	BW	
-	√	√	√	√	√	-

Where RE: Radiated Emission PLC: Power Line Conducted Emission
 FS: Frequency Stability BW: 20dB Bandwidth

POWER LINE CONDUCTED EMISSION TEST:

- Pre-Scan has been conducted to determine the worst-case mode from all possible combinations between available modulations and antenna ports (if EUT with antenna diversity architecture).
- Following channel(s) was (were) selected for the final test as listed below.

AVAILABLE CHANNEL	TESTED CHANNEL	MODULATION TYPE
1	1	ASK

RADIATED EMISSION TEST(BELOW 30MHz):

- Pre-Scan has been conducted to determine the worst-case mode from all possible combinations between available modulations antenna ports (if EUT with antenna diversity architecture).
- Following channel(s) was (were) selected for the final test as listed below.

AVAILABLE CHANNEL	TESTED CHANNEL	MODULATION TYPE
1	1	ASK

RADIATED EMISSION TEST(ABOVE 30MHz):

- Pre-Scan has been conducted to determine the worst-case mode from all possible combinations between available modulations antenna ports (if EUT with antenna diversity architecture).
- Following channel(s) was (were) selected for the final test as listed below.

AVAILABLE CHANNEL	TESTED CHANNEL	MODULATION TYPE
1	1	ASK

FREQUENCY STABILITY:

- Pre-Scan has been conducted to determine the worst-case mode from all possible combinations between available modulations and antenna ports (if EUT with antenna diversity architecture).
- Following channel(s) was (were) selected for the final test as listed below.

AVAILABLE CHANNEL	TESTED CHANNEL	MODULATION TYPE
1	1	ASK

20dB BANDWIDTH:

- Pre-Scan has been conducted to determine the worst-case mode from all possible combinations between available modulations, antenna ports (if EUT with antenna diversity architecture).
- Following channel(s) was (were) selected for the final test as listed below.

AVAILABLE CHANNEL	TESTED CHANNEL	MODULATION TYPE
1	1	ASK

TEST CONDITION:

APPLICABLE TO	ENVIRONMENTAL CONDITIONS	INPUT POWER	TESTED BY
PLC	25deg. C, 60%RH	120Vac, 60Hz	Jason Huang
RE	24deg. C, 64%RH	120Vac, 60Hz	Nelson Teng
	25deg. C, 65%RH	120Vac, 60Hz	Robert Cheng
	30deg. C, 70%RH	120Vac, 60Hz	Nelson Teng
BW	25deg. C, 60%RH	120Vac, 60Hz	Rex Huang
FS	25deg. C, 60%RH	120Vac, 60Hz	Rex Huang



A D T

3.3 GENERAL DESCRIPTION OF APPLIED STANDARDS

The EUT is a RF product. According to the specifications of the manufacturer, it must comply with the requirements of the following standards:

FCC Part 15, Subpart C (15.225)

FCC Part 15, Subpart C (15.215)

ANSI C63.10-2009

All test items have been performed and recorded as per the above standards.



3.4 DESCRIPTION OF SUPPORT UNITS

The EUT has been tested as an independent unit together with other necessary accessories or support units. The following support units or accessories were used to form a representative test configuration during the tests.

NO.	PRODUCT	BRAND	MODEL NO.	SERIAL NO.	FCC ID
1	NOTEBOOK COMPUTER	DELL	PP32LA	FSLB32S	FCC DoC
2	iPod shuffle	Apple	MC749TA/A	CC4DN25WDF DM	NA
3	iPod shuffle	Apple	MC749TA/A	CC4DMFJUDFD M	NA
4	PROGRAM-CON TROL TELEPHONE EXCHANGE	TELTONE	TC-104H	TC001	NA

NO.	SIGNAL CABLE DESCRIPTION OF THE ABOVE SUPPORT UNITS
1	UTP cable, 10m
2	USB cable, 0.1m
3	USB cable, 0.1m
4	RJ-11 cable, 10m

NOTE: All power cords of the above support units are non shielded (1.8m).

3.5 CONFIGURATION OF SYSTEM UNDER TEST

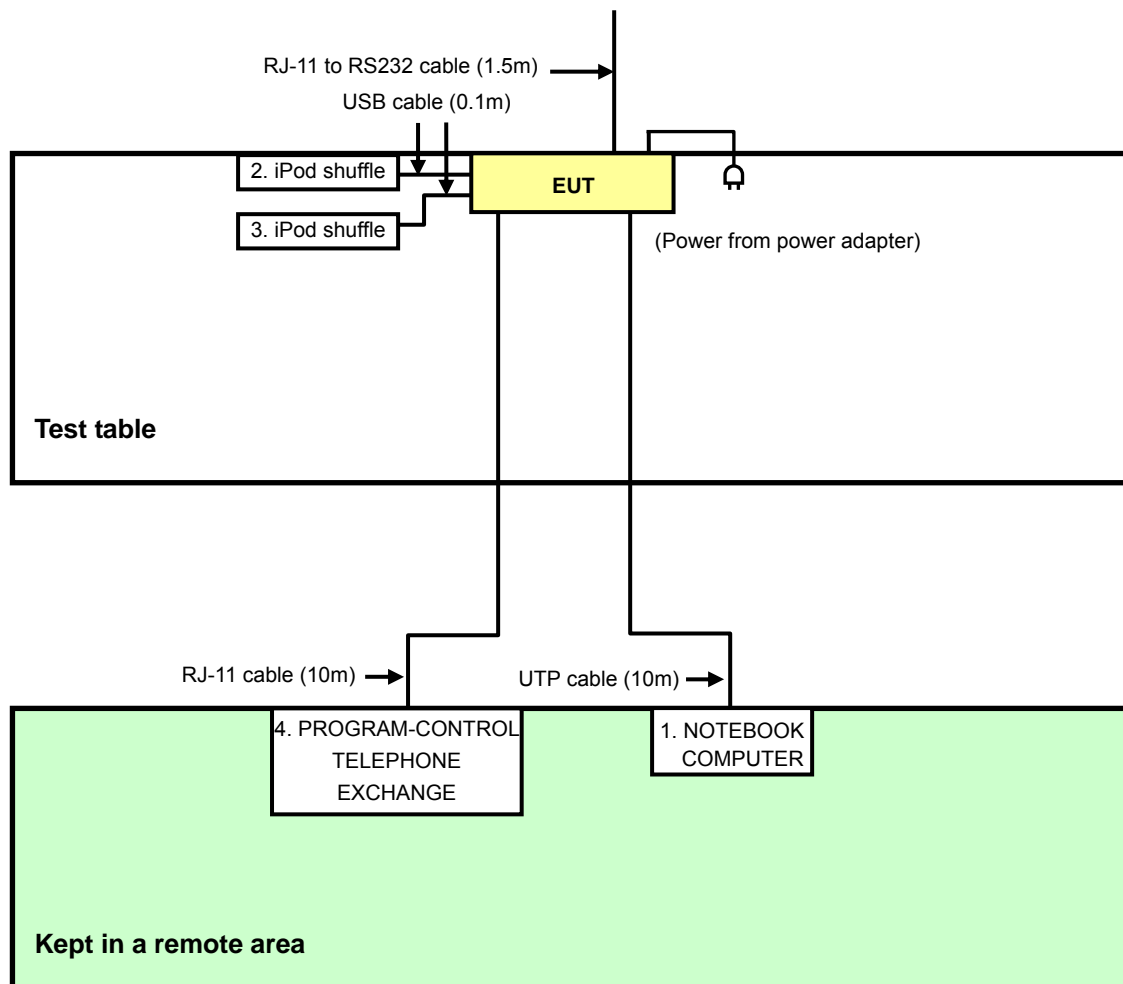



4 TEST PROCEDURES AND RESULTS

4.1 CONDUCTED EMISSION MEASUREMENT

4.1.1 LIMITS OF CONDUCTED EMISSION MEASUREMENT

FREQUENCY OF EMISSION (MHz)	CONDUCTED LIMIT (dBµV)	
	Quasi-peak	Average
0.15-0.5	66 to 56	56 to 46
0.5-5	56	46
5-30	60	50

NOTE:

1. The lower limit shall apply at the transition frequencies.
2. All emanations from a class B digital device or system, including any network of conductors and apparatus connected thereto, shall not exceed the level of field strengths specified above.

4.1.2 TEST INSTRUMENTS

DESCRIPTION & MANUFACTURER	MODEL NO.	SERIAL NO.	CALIBRATED DATE	CALIBRATED UNTIL
Test Receiver	ESCS 30	100375	Mar. 12, 2012	Mar. 11, 2013
Line-Impedance Stabilization Network (for EUT) SCHWARZBECK	NSLK8127	8127-522	Sep. 06, 2012	Sep. 05, 2013
Line-Impedance Stabilization Network (for Peripheral)	ENV216	100072	June 08,2012	June 07,2013
RF Cable (JYEBAO)	5DFB	COCCAB-001	Aug. 28, 2012	Aug. 27, 2013
50 ohms Terminator	50	EMC-3	Sep. 25, 2012	Sep. 24, 2013
Software ADT	BV ADT_Cond_V7.3.7.3	NA	NA	NA

Note:

1. The calibration interval of the above test instruments is 12 months and the calibrations are traceable to NML/ROC and NIST/USA.
2. The test was performed in Shielded Room No. C.
3. The VCCI Con C Registration No. is C-3611.
4. Tested Date: Dec. 14, 2012

4.1.3 TEST PROCEDURES

- a. The EUT/HOST was placed 0.4 meters from the conducting wall of the shielded room with EUT/HOST being connected to the power mains through a line impedance stabilization network (LISN). Other support units were connected to the power mains through another LISN. The two LISNs provide 50 ohm/ 50uH of coupling impedance for the measuring instrument.
- b. Both lines of the power mains connected to the EUT/HOST were checked for maximum conducted interference.
- c. The frequency range from 150kHz to 30MHz was searched. Emission levels under (Limit - 20dB) was not recorded.

NOTE:

1. The resolution bandwidth of test receiver is 9kHz for Quasi-peak detection (QP) & Average detection (AV).

4.1.4 DEVIATION FROM TEST STANDARD

No deviation

4.1.5 TEST SETUP

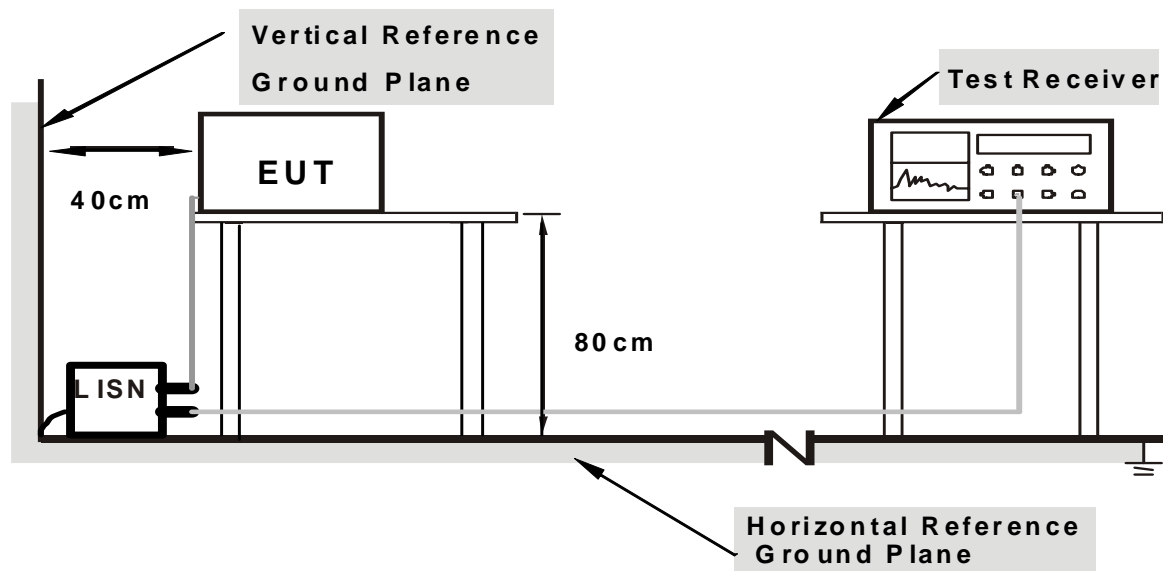

Note: 1. Support units were connected to second LISN.

For the actual test configuration, please refer to the related item – Photographs of the Test Configuration.

4.1.6 EUT OPERATING CONDITIONS

1. Turn on the power of EUT.
2. The communication partner run test program "RT5x7xQA.exe" to enable EUT under transmission/receiving condition continuously at specific channel frequency.

4.1.7 TEST RESULTS

PHASE	Line (L)	DETECTOR FUNCTION	Quasi-Peak (QP) / Average (AV)
-------	----------	-------------------	--------------------------------

No	Freq. [MHz]	Corr. Factor (dB)	Reading Value [dB (uV)]		Emission Level [dB (uV)]		Limit [dB (uV)]		Margin (dB)	
			Q.P.	AV.	Q.P.	AV.	Q.P.	AV.	Q.P.	AV.
1	0.16562	0.10	48.98	42.87	49.08	42.97	65.18	55.18	-16.10	-12.21
2	0.25822	0.12	36.64	13.05	36.76	13.17	61.49	51.49	-24.72	-38.31
3	0.40781	0.16	26.21	12.17	26.37	12.33	57.69	47.69	-31.32	-35.36
4	2.58433	0.26	23.76	15.97	24.02	16.23	56.00	46.00	-31.98	-29.77
5	3.63672	0.30	23.80	16.98	24.10	17.28	56.00	46.00	-31.90	-28.72
6	27.16016	1.31	35.29	32.60	36.60	33.91	60.00	50.00	-23.40	-16.09

REMARKS:

1. Q.P. and AV. are abbreviations of quasi-peak and average individually.
2. The emission levels of other frequencies were very low against the limit.
3. Margin value = Emission level – Limit value
4. Correction factor = Insertion loss + Cable loss
5. Emission Level = Correction Factor + Reading Value

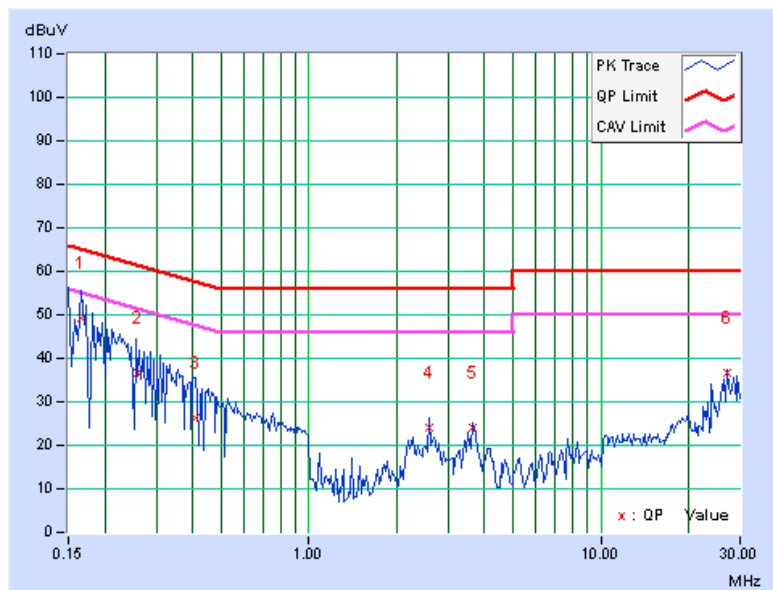

PHASE	Neutral (N)	DETECTOR FUNCTION	Quasi-Peak (QP) / Average (AV)
--------------	-------------	--------------------------	--------------------------------

No	Freq.	Corr.	Reading Value		Emission Level		Limit		Margin	
	[MHz]	Factor	[dB (uV)]		[dB (uV)]		[dB (uV)]		(dB)	
		(dB)	Q.P.	AV.	Q.P.	AV.	Q.P.	AV.	Q.P.	AV.
1	0.16562	0.05	47.31	41.66	47.36	41.71	65.18	55.18	-17.81	-13.46
2	0.21856	0.06	38.65	22.60	38.71	22.66	62.87	52.87	-24.16	-30.21
3	0.26558	0.08	35.69	20.33	35.77	20.41	61.26	51.26	-25.49	-30.85
4	0.33314	0.09	29.84	12.87	29.93	12.96	59.37	49.37	-29.44	-36.41
5	24.00000	0.95	33.39	32.15	34.34	33.10	60.00	50.00	-25.66	-16.90
6	26.61117	1.05	35.90	33.66	36.95	34.71	60.00	50.00	-23.05	-15.29

REMARKS:

1. Q.P. and AV. are abbreviations of quasi-peak and average individually.
2. The emission levels of other frequencies were very low against the limit.
3. Margin value = Emission level – Limit value
4. Correction factor = Insertion loss + Cable loss
5. Emission Level = Correction Factor + Reading Value

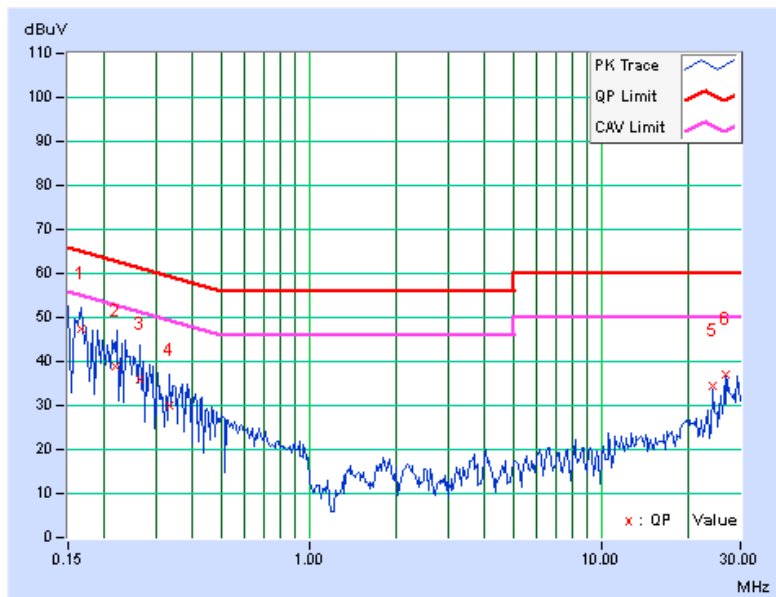



4.2 RADIATED EMISSION & OCCUPIED BANDWIDTH MEASUREMENT

4.2.1 LIMITS OF RADIATED EMISSION MEASUREMENT

The field strength of any emissions within the band 13.553-13.567 MHz shall not exceed 15,848 microvolts/meter at 30 meters.

The field strength of any emissions appearing outside of the 13.110-14.010 MHz band shall not exceed the general radiated emission limits in § 15.209.

FREQUENCIES (MHz)	FIELD STRENGTH (microvolts/meter)	MEASUREMENT DISTANCE (meters)
0.009 ~ 0.490	2400/F(kHz)	300
0.490 ~ 1.705	24000/F(kHz)	30
1.705 ~ 30.0	30	30
30 ~ 88	100	3
88 ~ 216	150	3
216 ~ 960	200	3
Above 960	500	3

NOTE:

1. The lower limit shall apply at the transition frequencies.
2. Emission level (dBuV/m) = 20 log Emission level (uV/m).
3. As shown in 15.35(b), for frequencies above 1000MHz, the field strength limits are based on average detector, however, the peak field strength of any emission shall not exceed the maximum permitted average limits, specified above by more than 20dB under any condition of modulation.



4.2.2 TEST INSTRUMENTS

For below 30MHz:

DESCRIPTION & MANUFACTURER	MODEL NO.	SERIAL NO.	CALIBRATED DATE	CALIBRATED UNTIL
Spectrum Analyzer Agilent	E4443A	MY48250349	July 24, 2012	July 23, 2013
	E4443A	MY49420002	Aug. 10, 2012	Aug. 09, 2013
Pre-Selector Agilent	N9039A	MY46520331	Aug. 10, 2012	Aug. 09, 2013
	N9039A	MY46520309	July 24, 2012	July 23, 2013
Signal Generator Agilent	N5181A	MY49060520	Aug. 10, 2012	Aug. 09, 2013
Pre-Amplifier Mini-Circuits	ZFL-1000VH2B	AMP-ZFL-01	Nov. 14, 2012	Nov. 13, 2013
	ZFL-1000VH2B	AMP-ZFL-02	Nov. 14, 2012	Nov. 13, 2013
Pre-Amplifier Mini-Circuits	ZVA-183-S+	AMP-ZVA-01	Nov. 14, 2012	Nov. 13, 2013
Pre-Amplifier SPACEK LABS	SLKka-48-6	9K16	Nov. 14, 2012	Nov. 13, 2013
Trilog Broadband Antenna SCHWARZBECK	VULB 9168	9168-359	Apr. 09, 2012	Apr. 08, 2013
	VULB 9168	9168-358	Apr. 06, 2012	Apr. 05, 2013
Spectrum Analyzer Agilent	E4446A	MY48250253	Aug. 28, 2012	Aug. 27, 2013
Horn Antenna SCHWARZBECK	BBHA 9170	9170-424	Oct. 06, 2012	Oct. 05, 2013
Loop Antenna ^(*) R&S	HFH2-Z2	100070	Jan. 31, 2012	Jan. 30, 2014
Test Receiver LIG	ER-265	L09068005	Mar. 14, 2012	Mar. 13, 2013
Pre-Amplifier Agilent	8449B	3008A01975	Mar. 03, 2012	Mar. 02, 2013
Horn Antenna SCHWARZBECK	BBHA 9120	9120D-783	Sep. 20, 2012	Sep. 19, 2013
RF Cable	NA	RF104-110 RF104-206 RF104-209	Dec. 20, 2012	Dec.19, 2013
RF Cable	8DFB	CHFCAB-001 CHFCAB-002 CHFCAB-003	Nov. 14, 2012	Nov. 13, 2013
Software	ADT_Radiated_ V8.7.06	NA	NA	NA
Antenna Tower & Turn Table CT	NA	NA	NA	NA

Note:

- The calibration interval of the above test instruments is 12 months and the calibrations are traceable to NML/ROC and NIST/USA.
*The calibration interval of the above test instruments is 24 months and the calibrations are traceable to NML/ROC and NIST/USA.
- The test was performed in 10m Chamber No. F.
- The FCC Site Registration No. is 928149.
- The VCCI Site Registration No. is R-3252 & G-136.
- The CANADA Site Registration No. is IC 7450H-1.
- Tested Date: Dec. 22, 2012

**For above 30MHz:**

DESCRIPTION & MANUFACTURER	MODEL NO.	SERIAL NO.	CALIBRATED DATE	CALIBRATED UNTIL
MXE EMI Receiver Agilent	N9038A	MY50010156	Jan. 16, 2013	Jan. 15, 2014
Pre-Amplifier Mini-Circuits	ZFL-1000VH2 B	AMP-ZFL-04	Nov. 14, 2012	Nov. 13, 2013
Trilog Broadband Antenna SCHWARZBECK	VULB 9168	9168-361	Mar. 25, 2013	Mar. 24, 2014
RF Cable	NA	CHHCAB_001	Oct. 06, 2013	Oct. 05, 2014
Horn_Antenna AISI	AIH.8018	0000220091110	Nov. 27, 2012	Nov. 26, 2013
Pre-Amplifier Agilent	8449B	3008A01923	Oct. 29, 2013	Oct. 28, 2014
RF Cable	NA	RF104-205 RF104-207 RF104-202	Dec. 26, 2012	Dec. 25, 2013
Spectrum Analyzer Agilent	E4446A	MY48250253	Aug. 28, 2013	Aug. 27, 2014
Pre-Amplifier SPACEK LABS	SLKKa-48-6	9K16	Nov. 14, 2012	Nov. 13, 2013
Horn_Antenna SCHWARZBECK	BBHA 9170	9170-424	Oct. 08, 2013	Oct. 07, 2014
Software	ADT_Radiated _V8.7.07	NA	NA	NA
Antenna Tower & Turn Table CT	NA	NA	NA	NA

Note:

1. The calibration interval of the above test instruments is 12 months and the calibrations are traceable to NML/ROC and NIST/USA.
2. The horn antenna, preamplifier (model: 8449B) are used only for the measurement of emission frequency above 1GHz if tested.
3. The test was performed in 966 Chamber No. H.
4. The FCC Site Registration No. is 797305.
5. The CANADA Site Registration No. is IC 7450H-3.
6. Tested Date: Oct. 30, 2013

4.2.3 TEST PROCEDURES

For Radiated emission below 30MHz

- a. The EUT was placed on the top of a rotating table 0.8 meters above the ground at a 10 meter chamber room. The table was rotated 360 degrees to determine the position of the highest radiation.
- b. The EUT was set 10 meters away from the interference-receiving antenna, which was mounted on the top of a variable-height antenna tower.
- c. Both X and Y axes of the antenna are set to make the measurement.
- d. For each suspected emission, the EUT was arranged to its worst case and the rotatable table was turned from 0 degrees to 360 degrees to find the maximum reading.
- e. The test-receiver system was set to Quasi-Peak Detect Function and Specified Bandwidth with Maximum Hold Mode.

NOTE:

1. The resolution bandwidth and video bandwidth of test receiver/spectrum analyzer is 9kHz at frequency below 30MHz.

For Radiated emission 30~1000MHz

- a. The EUT was placed on the top of a rotating table 0.8 meters above the ground at a 3 meter chamber room. The table was rotated 360 degrees to determine the position of the highest radiation.
- b. The EUT was set 3 meters away from the interference-receiving antenna, which was mounted on the top of a variable-height antenna tower.
- c. The height of antenna is varied from one meter to four meters above the ground to determine the maximum value of the field strength. Both horizontal and vertical polarizations of the antenna are set to make the measurement.
- d. For each suspected emission, the EUT was arranged to its worst case and then the antenna was tuned to heights from 1 meter to 4 meters and the rotatable table was turned from 0 degrees to 360 degrees to find the maximum reading.
- e. The test-receiver system was set to Quasi-Peak Detect Function and Specified Bandwidth with Maximum Hold Mode.

NOTE:

1. The resolution bandwidth and video bandwidth of test receiver/spectrum analyzer is 120kHz for Quasi-peak detection (QP) at frequency 30MHz ~ 1GHz.

4.2.4 DEVIATION FROM TEST STANDARD

No deviation

4.2.5 TEST SETUP

For Radiated emission below 30MHz

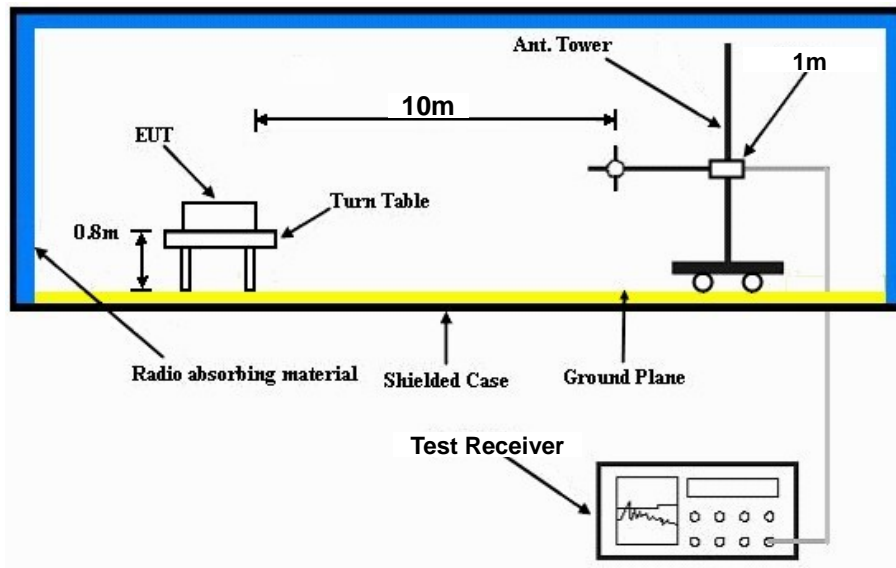

For Radiated emission 30~1000MHz

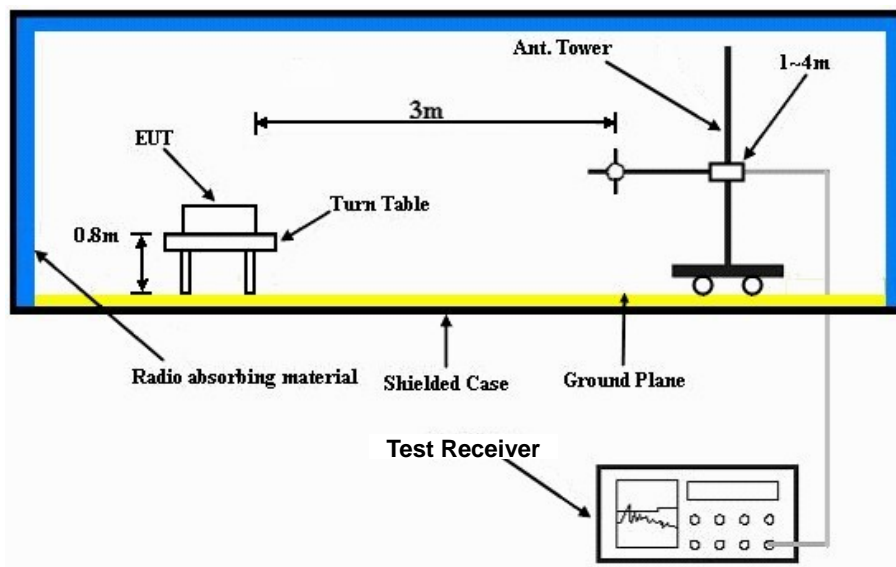

For the actual test configuration, please refer to the related item in this test report - Photographs of the Test Configuration.



4.2.6 EUT OPERATING CONDITIONS

Set the transmitter part of EUT under transmission condition continuously at specific channel frequency.

4.2.7 TEST RESULTS

EUT TEST CONDITION		MEASUREMENT DETAIL	
INPUT POWER	120Vac, 60Hz	FREQUENCY RANGE	13.553 ~ 13.567MHz
ENVIRONMENTAL CONDITIONS	24deg. C, 64%RH	DETECTOR FUNCTION	Quasi-Peak (QP)
TESTED BY	Nelson Teng		

LOOP ANTENNA TEST DISTANCE: AT 10 M (X AXIS)								
No.	Freq. (MHz)	Emission Level (dBuV/m)	Limit (dBuV/m)	Margin (dB)	Antenna Height (m)	Table Angle (Degree)	Raw Value (dBuV)	Correction Factor (dB/m)
1	*13.56	53.24 QP	103.10	-49.86	1.00	83	53.24	0.00

- REMARKS:**
1. Emission level(dBuV/m)=Raw Value(dBuV) + Correction Factor(dB/m)
 2. Correction Factor (dB/m) = Antenna Factor (dB/m) + Cable Factor (dB) – Pre-Amplifier Factor(dB)
 3. The other emission levels were very low against the limit.
 4. Margin value = Emission level – Limit value
 5. “ * “: Fundamental frequency.

The measured field strength was extrapolated to distance 30 meters, using the formula that the limit of field strength varies as the inverse distance square (40dB per decade of distance)

Example:

$$\begin{aligned}
 13.56\text{MHz} &= 15848\mu\text{V/m} && 30\text{m} \\
 &= 84\text{dBuV/m} && 30\text{m} \\
 &= 84+20\log(30/10)^2 && 10\text{m} \\
 &= 103.1\text{dBuV/m}
 \end{aligned}$$

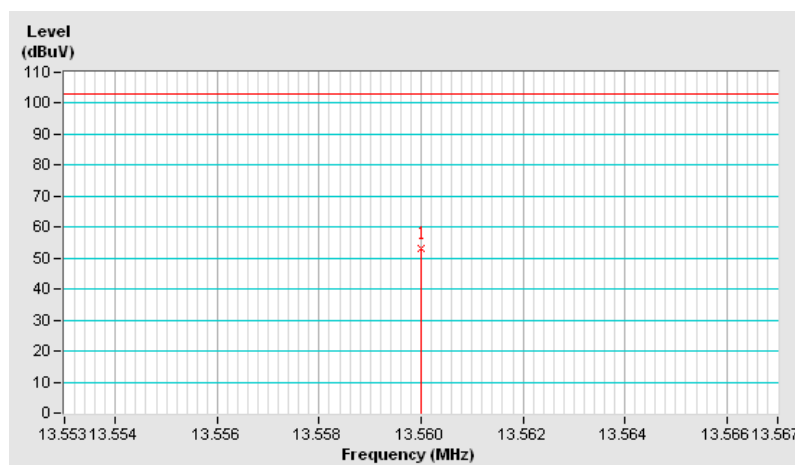



EUT TEST CONDITION		MEASUREMENT DETAIL	
INPUT POWER	120Vac, 60Hz	FREQUENCY RANGE	13.553 ~ 13.567MHz
ENVIRONMENTAL CONDITIONS	24deg. C, 64%RH	DETECTOR FUNCTION	Quasi-Peak (QP)
TESTED BY	Nelson Teng		

LOOP ANTENNA TEST DISTANCE: AT 10 M (Y AXIS)								
No.	Freq. (MHz)	Emission Level (dBuV/m)	Limit (dBuV/m)	Margin (dB)	Antenna Height (m)	Table Angle (Degree)	Raw Value (dBuV)	Correction Factor (dB/m)
1	*13.56	61.14 QP	103.10	-41.96	1.00	27	61.14	0.00

- REMARKS:**
1. Emission level(dBuV/m)=Raw Value(dBuV) + Correction Factor(dB/m)
 2. Correction Factor (dB/m) = Antenna Factor (dB/m) + Cable Factor (dB) – Pre-Amplifier Factor(dB)
 3. The other emission levels were very low against the limit.
 4. Margin value = Emission level – Limit value
 5. “ * “: Fundamental frequency.

The measured field strength was extrapolated to distance 30 meters, using the formula that the limit of field strength varies as the inverse distance square (40dB per decade of distance)

Example:

$$\begin{aligned}
 13.56\text{MHz} &= 15848\mu\text{V/m} && 30\text{m} \\
 &= 84\text{dBuV/m} && 30\text{m} \\
 &= 84+20\log(30/10)^2 && 10\text{m} \\
 &= 103.1\text{dBuV/m}
 \end{aligned}$$

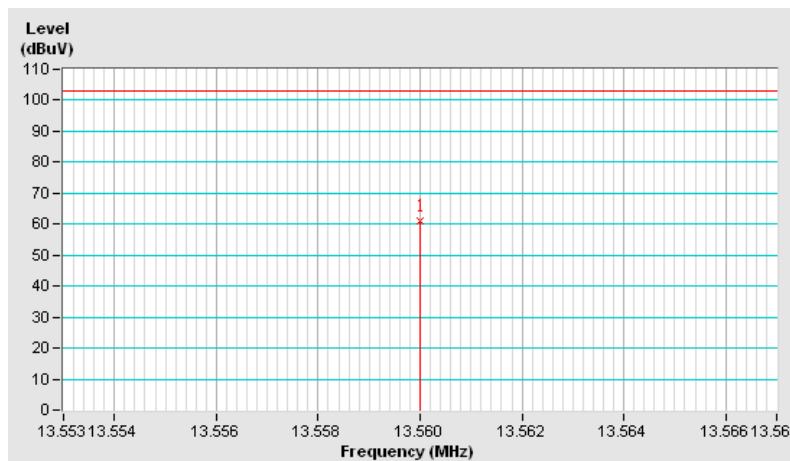



EUT TEST CONDITION		MEASUREMENT DETAIL	
INPUT POWER	120Vac, 60Hz	FREQUENCY RANGE	Below 30MHz
ENVIRONMENTAL CONDITIONS	24deg. C, 64%RH	DETECTOR FUNCTION	Quasi-Peak (QP)
TESTED BY	Nelson Teng		

LOOP ANTENNA TEST DISTANCE: AT 10 M (X AXIS)								
No.	Freq. (MHz)	Emission Level (dBuV/m)	Limit (dBuV/m)	Margin (dB)	Antenna Height (m)	Table Angle (Degree)	Raw Value (dBuV)	Correction Factor (dB/m)
1	0.25	43.40 QP	78.74	-35.34	1.00	15	43.40	0.00
2	1.50	38.10 QP	43.21	-5.11	1.00	43	38.10	0.00
3	27.12	30.60 QP	48.60	-18.00	1.00	33	30.60	0.00
LOOP ANTENNA TEST DISTANCE: AT 10 M (Y AXIS)								
No.	Freq. (MHz)	Emission Level (dBuV/m)	Limit (dBuV/m)	Margin (dB)	Antenna Height (m)	Table Angle (Degree)	Raw Value (dBuV)	Correction Factor (dB/m)
1	0.25	44.04 QP	78.74	-34.70	1.00	151	44.04	0.00
2	0.50	41.64 QP	52.78	-11.14	1.00	122	41.64	0.00
3	27.12	37.30 QP	48.60	-11.30	1.00	141	37.30	0.00

- REMARKS:**
1. Emission level (dBuV/m) = Raw Value (dBuV) + Correction Factor (dB/m).
 2. Correction Factor (dB/m) = Antenna Factor (dB/m) + Cable Factor (dB)
– Pre-Amplifier Factor(dB)
 3. The other emission levels were very low against the limit.
 4. Margin value = Emission level – Limit value



EUT TEST CONDITION		MEASUREMENT DETAIL	
INPUT POWER	120Vac, 60Hz	FREQUENCY RANGE	Above 30MHz
ENVIRONMENTAL CONDITIONS	25deg. C, 65%RH	DETECTOR FUNCTION	Quasi-Peak (QP)
TESTED BY	Robert Cheng		

ANTENNA POLARITY & TEST DISTANCE: HORIZONTAL AT 3 M								
NO.	FREQ. (MHz)	EMISSION LEVEL (dBuV/m)	LIMIT (dBuV/m)	MARGIN (dB)	ANTENNA HEIGHT (m)	TABLE ANGLE (Degree)	RAW VALUE (dBuV)	CORRECTION FACTOR (dB/m)
1	75.31	38.6 QP	40.0	-1.4	2.00 H	150	55.26	-16.63
2	116.09	39.0 QP	43.5	-4.5	1.75 H	278	54.06	-15.02
3	156.90	37.8 QP	43.5	-5.7	1.75 H	100	50.64	-12.81
4	241.00	43.5 QP	46.0	-2.5	1.25 H	60	57.42	-13.95
5	327.01	42.4 QP	46.0	-3.7	1.00 H	325	53.25	-10.90
6	400.01	39.1 QP	46.0	-6.9	1.25 H	337	48.58	-9.50

ANTENNA POLARITY & TEST DISTANCE: VERTICAL AT 3 M								
NO.	FREQ. (MHz)	EMISSION LEVEL (dBuV/m)	LIMIT (dBuV/m)	MARGIN (dB)	ANTENNA HEIGHT (m)	TABLE ANGLE (Degree)	RAW VALUE (dBuV)	CORRECTION FACTOR (dB/m)
1	75.20	39.2 QP	40.0	-0.8	1.00 V	150	55.81	-16.58
2	116.29	40.1 QP	43.5	-3.4	1.00 V	360	55.11	-14.98
3	240.31	44.6 QP	46.0	-1.4	1.00 V	2	58.54	-13.98
4	252.33	43.0 QP	46.0	-3.0	1.75 V	358	56.74	-13.71
5	264.01	43.9 QP	46.0	-2.1	1.50 V	357	57.16	-13.27
6	400.01	40.3 QP	46.0	-5.8	1.75 V	107	49.75	-9.50

REMARKS:

1. Emission Level(dBuV/m) = Raw Value(dBuV) + Correction Factor(dB/m)
2. Correction Factor(dB/m) = Antenna Factor(dB/m) + Cable Factor(dB) – Pre-Amplifier Factor(dB)
3. The other emission levels were very low against the limit.
4. Margin value = Emission Level – Limit value



4.3 20dB BANDWIDTH

4.3.1 LIMITS OF 20dB BANDWIDTH MEASUREMENT

The 20dB bandwidth shall be specified in operating frequency band.

4.3.2 TEST INSTRUMENTS

DESCRIPTION & MANUFACTURER	MODEL NO.	SERIAL NO.	CALIBRATED DATE	CALIBRATED UNTIL
R&S SPECTRUM ANALYZER	FSP40	100060	May 09, 2012	May 10, 2013

Note:

1. The calibration interval of the above test instruments is 12 months and the calibrations are traceable to NML/ROC and NIST/USA.
2. Tested date : Jan. 08, 2013

4.3.3 EUT OPERATING CONDITION

The bandwidth of the fundamental frequency was measured by spectrum analyzer with 10kHz RBW and 30kHz VBW. The 20dB bandwidth is defined as the total spectrum the power of which is higher than peak power minus 20dB.

4.3.4 TEST RESULTS

20dBc point (Low)	20dBc point (High)	Operating frequency band (MHz)	PASS/FAIL
13.48 MHz	13.71 MHz	13.11 – 14.01	PASS

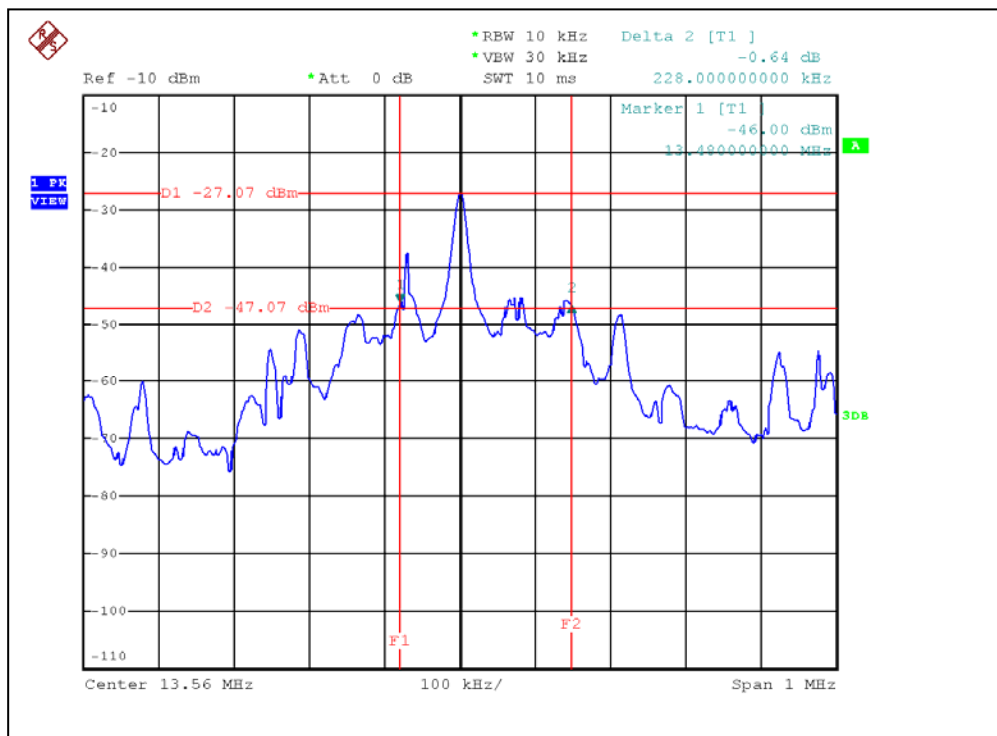



4.4 FREQUENCY STABILITY

4.4.1 LIMITS OF FREQUENCY STABILITY MEASUREMENT

The frequency tolerance of the carrier signal shall be maintained within $\pm 0.01\%$ ($\pm 100\text{ppm}$) of the operating frequency over a temperature variation of -20 degrees to 50 degrees C at normal supply voltage, and for a variation in the primary supply voltage from 85% to 115% of the rated supply voltage at a temperature of 20 degrees C.

4.4.2 TEST INSTRUMENTS

DESCRIPTION & MANUFACTURER	MODEL NO.	SERIAL NO.	CALIBRATED DATE	CALIBRATED UNTIL
R&S SPECTRUM ANALYZER	FSP40	100060	May 09, 2012	May 10, 2013

Note:

1. The calibration interval of the above test instruments is 12 months and the calibrations are traceable to NML/ROC and NIST/USA.
2. Tested date : Jan. 08, 2013

4.4.3 TEST PROCEDURE

1. The EUT was placed inside the environmental test chamber and powered by nominal AC voltage.
2. Turn the EUT on and couple its output to a spectrum analyzer.
3. Turn the EUT off and set the chamber to the highest temperature specified.
4. Allow sufficient time (approximately 30 min) for the temperature of the chamber to stabilize, turn the EUT on and measure the operating frequency after 2, 5, and 10 minutes.
5. Repeat step 2 and 3 with the temperature chamber set to the lowest temperature.
6. The test chamber was allowed to stabilize at $+20$ degree C for a minimum of 30 minutes. The supply voltage was then adjusted on the EUT from 85% to 115% and the frequency record.

4.4.4 DEVIATION FROM TEST STANDARD

No deviation

4.4.5 TEST SETUP

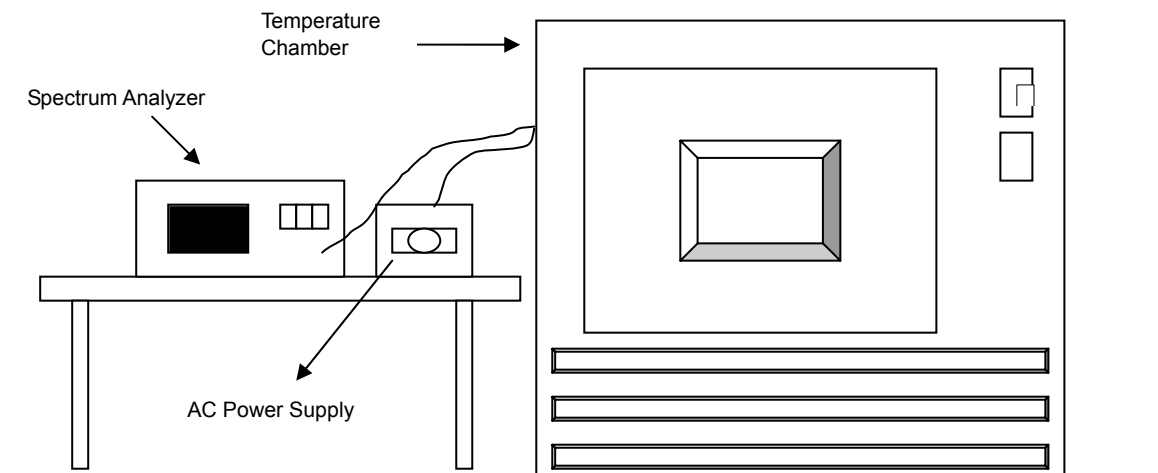

4.4.6 EUT OPERATING CONDITION

The software provided by client to enable the EUT under transmission condition continuously at specific channel frequencies individually.



4.4.7 TEST RESULTS

FREQUENCY STABILITY VERSUS TEMP.									
TEMP. (°C)	POWER SUPPLY (Vac)	0 MINUTE		2 MINUTE		5 MINUTE		10 MINUTE	
		Measured Frequency	Frequency Drift	Measured Frequency	Frequency Drift	Measured Frequency	Frequency Drift	Measured Frequency	Frequency Drift
		(MHz)	ppm	(MHz)	ppm	(MHz)	ppm	(MHz)	ppm
50	120	13.5599831	-1.2463	13.5599834	-1.2242	13.5599801	-1.4676	13.5599802	-1.4602
40	120	13.5600167	1.2316	13.5600136	1.0029	13.560016	1.1799	13.5600108	0.7965
30	120	13.5600148	1.0914	13.5600193	1.4233	13.5600182	1.3422	13.5600162	1.1947
20	120	13.5599893	-0.7891	13.5599852	-1.0914	13.5599861	-1.0251	13.5599865	-0.9956
10	120	13.5599851	-1.0988	13.5599837	-1.2021	13.5599862	-1.0177	13.5599888	-0.8260
0	120	13.5599993	-0.5162	13.5599954	-0.3392	13.5599929	-0.5236	13.5599889	-0.8186
-10	120	13.5599856	-1.0619	13.5599821	-1.3201	13.5599817	-1.3496	13.5599871	-0.9513
-20	120	13.5599953	-0.3466	13.5599994	-0.0442	13.5599982	-0.1327	13.5600013	0.0959
-30	120	13.5599957	-0.3171	13.5599998	-0.0147	13.5600027	0.1991	13.5600046	0.3392

FREQUENCY STABILITY VERSUS VOLTAGE									
TEMP. (°C)	POWER SUPPLY (Vac)	0 MINUTE		2 MINUTE		5 MINUTE		10 MINUTE	
		Measured Frequency	Frequency Drift	Measured Frequency	Frequency Drift	Measured Frequency	Frequency Drift	Measured Frequency	Frequency Drift
		(MHz)	ppm	(MHz)	ppm	(MHz)	ppm	(MHz)	ppm
20	138	13.5599877	-0.9071	13.559986	-1.0324	13.5599865	-0.9956	13.5599871	-0.9513
	120	13.5599893	-0.7891	13.5599852	-1.0914	13.5599861	-1.0251	13.5599865	-0.9956
	102	13.559988	-0.8850	13.5599858	-1.0472	13.559985	-1.1062	13.5599858	-1.0472



A D T

5 INFORMATION ON THE TESTING LABORATORIES

We, Bureau Veritas Consumer Products Services (H.K.) Ltd., Taoyuan Branch, were founded in 1988 to provide our best service in EMC, Radio, Telecom and Safety consultation. Our laboratories are accredited and approved according to ISO/IEC 17025.

If you have any comments, please feel free to contact us at the following:

Linko EMC/RF Lab:

Tel: 886-2-26052180

Fax: 886-2-26051924

Hsin Chu EMC/RF Lab:

Tel: 886-3-5935343

Fax: 886-3-5935342

Hwa Ya EMC/RF/Safety/Telecom Lab:

Tel: 886-3-3183232

Fax: 886-3-3270892

Email: service.adt@tw.bureauveritas.com

Web Site: www.bureauveritas-adt.com

The address and road map of all our labs can be found in our web site also.



A D T

6 APPENDIX-A- MODIFICATIONS RECORDERS FOR ENGINEERING CHANGES TO THE EUT BY THE LAB

No any modifications are made to the EUT by the lab during the test.

--- END ---