



A D T

FCC TEST REPORT

REPORT NO.: RF110726E01A

MODEL NO.: FD-400TiC

FCC ID: MQT-FD400TIC

RECEIVED: July 26, 2011

TESTED: Aug. 10 to 29, 2011

ISSUED: Oct. 19, 2011

APPLICANT: XAC Automation Corporation

ADDRESS: 4F, NO. 30, INDUSTRY E. RD. IX,
SCIENCE-BASED INDUSTRIAL PARK,
HSINCHU, TAIWAN

ISSUED BY: Bureau Veritas Consumer Products Services
(H.K.) Ltd., Taoyuan Branch Hsin Chu Laboratory

LAB ADDRESS : No. 81-1, Lu Liao Keng, 9th Ling,Wu Lung Tsuen,
Chiung Lin Hsiang, Hsin Chu Hsien 307, Taiwan

TEST LOCATION (1): No. 81-1, Lu Liao Keng, 9th Ling,Wu Lung Tsuen,
Chiung Lin Hsiang, Hsin Chu Hsien 307, Taiwan

TEST LOCATION (2): No. 49, Ln. 206, Wende Rd., Shangshan Tsuen,
Chiung Lin Hsiang, Hsin Chu Hsien 307, Taiwan

This test report consists of 31 pages in total. It may be duplicated completely for legal use with the approval of the applicant. It should not be reproduced except in full, without the written approval of our laboratory. The client should not use it to claim product certification, approval, or endorsement by TAF or any government agencies. The test results in the report only apply to the tested sample.





Table of Contents

RELEASE CONTROL RECORD.....	4
1 CERTIFICATION.....	5
2 SUMMARY OF TEST RESULTS.....	6
2.1 MEASUREMENT UNCERTAINTY.....	7
3 GENERAL INFORMATION	8
3.1 GENERAL DESCRIPTION OF EUT.....	8
3.2 DESCRIPTION OF TEST MODES.....	9
3.3 GENERAL DESCRIPTION OF APPLIED STANDARDS	10
3.4 DESCRIPTION OF SUPPORT UNITS.....	11
3.5 CONFIGURATION OF SYSTEM UNDER TEST	12
4 TEST PROCEDURES AND RESULTS	13
4.1 CONDUCTED EMISSION MEASUREMENT	13
4.1.1 LIMITS OF CONDUCTED EMISSION MEASUREMENT.....	13
4.1.2 TEST INSTRUMENTS	13
4.1.3 TEST PROCEDURES.....	14
4.1.4 DEVIATION FROM TEST STANDARD	14
4.1.5 TEST SETUP	15
4.1.6 EUT OPERATING CONDITIONS.....	15
4.1.7 TEST RESULTS.....	16
4.2 RADIATED EMISSION & OCCUPIED BANDWIDTH EASUREMENT	18
4.2.1 LIMITS OF RADIATED EMISSION MEASUREMENT.....	18
4.2.2 TEST INSTRUMENTS	19
4.2.3 TEST PROCEDURES.....	20
4.2.4 DEVIATION FROM TEST STANDARD	21
4.2.5 TEST SETUP	22
4.2.6 EUT OPERATING CONDITIONS.....	22
4.2.7 TEST RESULTS (RADIATED EMISSION BELOW 30MHZ).....	23
4.2.8 TEST RESULTS (RADIATED EMISSION 30~1000MHZ)	24
4.3 OPERATING FREQUENCY MEASUREMENT	25
4.3.1 TEST INSTRUMENTS	25
4.3.2 EUT OPERATING CONDITION	25
4.3.3 TEST RESULTS.....	26
4.4 FREQUENCY STABILITY	27
4.4.1 LIMITS OF FREQUENCY STABILITY MEASUREMENT.....	27
4.4.2 TEST INSTRUMENTS	27
4.4.3 TEST PROCEDURE	27
4.4.4 DEVIATION FROM TEST STANDARD	28



A D T

4.4.5	TEST SETUP	28
4.4.6	EUT OPERATING CONDITION	28
4.4.7	TEST RESULTS	29
5	INFORMATION ON THE TESTING LABORATORIES	30
6	APPENDIX-A- MODIFICATIONS RECORDERS FOR ENGINEERING CHANGES TO THE EUT BY THE LAB	31



A D T

RELEASE CONTROL RECORD

ISSUE NO.	REASON FOR CHANGE	DATE ISSUED
RF110726E01A	Original release	Oct. 19, 2011



A D T

1 CERTIFICATION

PRODUCT : Portable Terminal
BRAND NAME : First Data
MODEL NO. : FD-400TiC
TEST SAMPLE : R&D SAMPLE
APPLICANT : XAC Automation Corporation
TESTED : Aug. 10 to 29, 2011
STANDARDS : 47 CFR Part 15, Subpart C(Section 15.225)
ANSI C63.4: 2003
NSI C63.10-2009

The above equipment (Model: FD-400TiC) has been tested by **Bureau Veritas Consumer Products Services (H.K.) Ltd., Taoyuan Branch**, and found compliance with the requirement of the above standards. The test record, data evaluation & Equipment Under Test (EUT) configurations represented herein are true and accurate accounts of the measurements of the sample's EMC characteristics under the conditions specified in this report.

PREPARED BY :  , **DATE:** Oct. 19, 2011
(Claire Kuan, Specialist)

APPROVED BY :  , **DATE:** Oct. 19, 2011
(May Chen, Deputy Manager)

2 SUMMARY OF TEST RESULTS

The EUT has been tested according to the following specifications:

APPLIED STANDARD: FCC Part 15, Subpart C			
STANDARD PARAGRAPH	TEST TYPE	RESULT	REMARK
15.207	Conducted Emission Test	PASS	Meet the requirement of limit. Minimum passing margin is -17.95dB at 4.762MHz
15.225 / 15.209	Radiated Emission Test	PASS	Meet the requirement of limit. Minimum passing margin is -2.08 dB at 196.62 MHz
15.225 / 15.215	Operating Frequency Measurement	PASS	Operation within the band 13.110-14.010 MHz
15.225(e)	Frequency Stability Measurement	PASS	Meet the requirement of limit
15.203	Antenna Requirement	PASS	No antenna connector is used.

2.1 MEASUREMENT UNCERTAINTY

Where relevant, the following measurement uncertainty levels have been estimated for tests performed on the EUT as specified in CISPR 16-4-2:

This uncertainty represents an expanded uncertainty expressed at approximately the 95% confidence level using a coverage factor of $k=2$.

Measurement	Value
Conducted Emission	2.45 dB
Radiated emissions	3.81 dB

3 GENERAL INFORMATION

3.1 GENERAL DESCRIPTION OF EUT

PRODUCT	Portable Terminal
MODEL NO.	FD-400TiC
FCC ID	MQT-FD400TIC
POWER SUPPLY	DC 12V from adapter or DC7.4V from battery
MODULATION TYPE	ASK
OPERATING FREQUENCY	13.56MHz
NUMBER OF CHANNEL	1
ANTENNA TYPE	Please see note
DATA CABLE	NA
I/O PORTS	USB port x 1
ASSOCIATED DEVICES	Adapter x 1

NOTE:

1. There are RFID, GPRS, WCDMA(UMTS), HSDPA and E-GPRS technology used for the EUT. and the functions of EUT listed as below table:

Function	Report No.
RFID	RF110726E01A
2G & 3G (Part 22)	RF110726E01A-1
2G & 3G (Part 24)	RF110726E01A-2

2. The emission of the simultaneous operation (RFID & GPRS, WCDMA(UMTS), HSDPA and E-GPRS) has been evaluated and no non-compliance found.

3. The EUT could be supplied with 7.4V battery or power adapter as the following table:

Item	Brand	Model No.	Spec.
Battery	CHENG UEI PRECISION INDUSTRY CO.,LTD	FD400	DC7.4V, 2300mAh(17.02Wh)
Adapter	DELTA	ADP-36JH B	AC I/P: 100-240V, 50/60Hz, 1.0A AC input cable: Unshielded, 1.85m DC O/P: 12V, 3A DC output cable: Unshielded, 1.8m with one core

4. There are two antennas provided to this EUT, please refer to the following table:

RFID Antenna Spec.					
Brand	Model No.	Antenna Type	Antenna Connector	Gain(dBi)	Frequency range (MHz)
XAC	PCB OSP ANTENNA BOARD FD400 (ROHS)	PCB (2 Layers)	NA	13	13.56
GPRS / WCDMA(UMTS) / HSDPA / E-GPRS Antenna Spec.					
Brand	Model No.	Antenna Type	Antenna Connector	Gain(dBi)	Frequency range (MHz to MHz)
Ethertronics Inc.	T-000084-01	FPCB	NA	1.65	824~894 1850~1990

5. The EUT was pre-tested in chamber under the following modes

Pre-test Mode	Description
Mode A	Battery mode
Mode B	Adapter mode

From the above modes, the radiated test worst case was found in **Mode A**. Therefore only the test data of the modes were recorded in this report.

6. The above EUT information was declared by the manufacturer and for more detailed features description, please refer to the manufacturer's specifications or User's Manual.

3.2 DESCRIPTION OF TEST MODES

The EUT only has 1 channel.

CHANNEL	FREQUENCY (MHz)
1	13.56



A D T

3.3 GENERAL DESCRIPTION OF APPLIED STANDARDS

The EUT is a RF product. According to the specifications of the manufacturer, it must comply with the requirements of the following standards:

47 CFR Part 15, Subpart C (Section 15.225)

ANSI C63.4-2003

ANSI C63.10-2009

All tests have been performed and recorded as per the above standards.



3.4 DESCRIPTION OF SUPPORT UNITS

The EUT has been tested as an independent unit together with other necessary accessories or support units. The following support units or accessories were used to form a representative test configuration during the tests.

Conducted Emission test					
No.	Product	Brand	Model No.	Serial No.	FCC ID
1	NOTEBOOK COMPUTER	DELL	PP32LA	HSLB32S	FCC DoC
2	PRINTER	EPSON	LQ-300+II	G88Y074083	FCC DoC
3	MOUSE	DELL	MOC5UO	I1401MLU	FCC DoC
4	iPod	Apple	MC749TA/A	CC4DMFJUDFDM	FCC DoC
Radiated test					
No.	Product	Brand	Model No.	Serial No.	FCC ID
1	iPod	Apple	MC749TA/A	CC4DMFJUDFDM	FCC DoC

Conducted Emission test	
No.	Signal cable description
1	1.8m, USB cable.
2	1.8m, USB cable
3	1.8 m foil shielded wire, terminated with USB connector via drain wire, w/o core.
4	5cm, USB Cable.
Radiated test	
No.	Signal cable description
1	5cm, USB Cable.

Note: 1. All power cords of the above support units are unshielded (1.8m).

3.5 CONFIGURATION OF SYSTEM UNDER TEST

For Conducted Emission test:

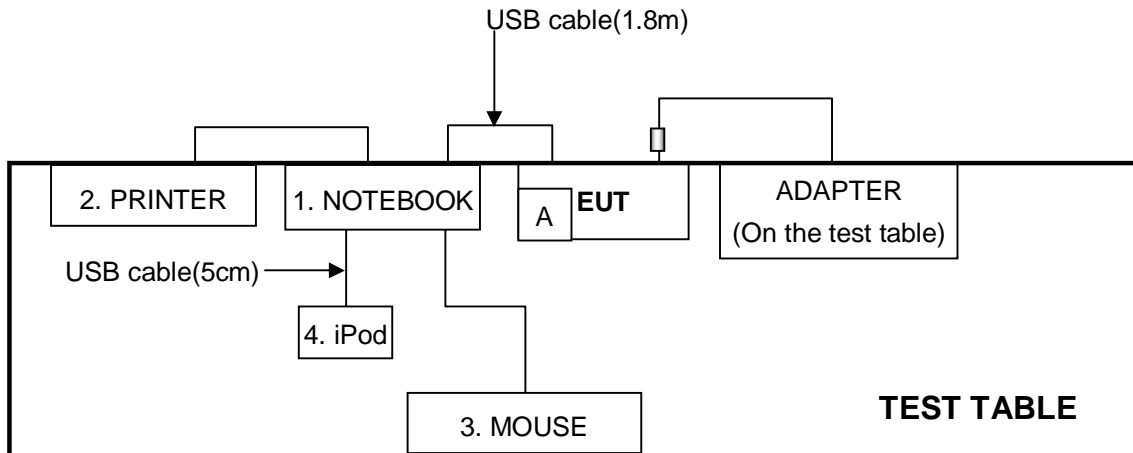

Note: The item A is battery.

For radiated test:

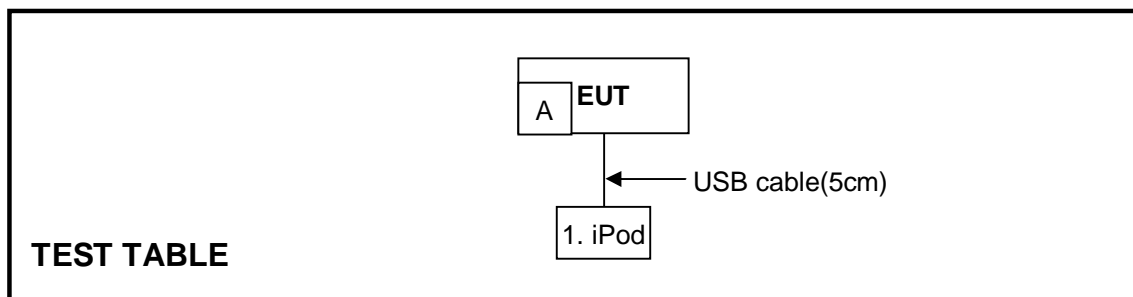

Note: The item A is battery.



4 TEST PROCEDURES AND RESULTS

4.1 CONDUCTED EMISSION MEASUREMENT

4.1.1 LIMITS OF CONDUCTED EMISSION MEASUREMENT

FREQUENCY OF EMISSION (MHz)	CONDUCTED LIMIT (dB μ V)	
	Quasi-peak	Average
0.15-0.5	66 to 56	56 to 46
0.5-5	56	46
5-30	60	50

NOTE:

1. The lower limit shall apply at the transition frequencies.
2. All emanations from a class B digital device or system, including any network of conductors and apparatus connected thereto, shall not exceed the level of field strengths specified above.

4.1.2 TEST INSTRUMENTS

Test date: Aug. 10, 2011

DESCRIPTION & MANUFACTURER	MODEL NO.	SERIAL NO.	CALIBRATED DATE	CALIBRATED UNTIL
Test Receiver	ESCS 30	100375	Mar. 09, 2011	Mar. 08, 2012
Line-Impedance Stabilization Network (for EUT)	NSLK 8127	8127-522	Sep. 08, 2010	Sep. 07, 2011
Line-Impedance Stabilization Network (for Peripheral)	ESH3-Z5	848773/004	Nov. 03, 2010	Nov. 02, 2011
RF Cable (JYEBAO)	5DFB	COCCAB-002	Aug. 30, 2010	Sep. 05, 2011
50 ohms Terminator	50	3	Oct. 07, 2010	Oct. 06, 2011
Software	BV ADT_Cond_V7.3.7	NA	NA	NA

Note:

1. The calibration interval of the above test instruments is 12 months and the calibrations are traceable to NML/ROC and NIST/USA.
2. The test was performed in Shielded Room No. C.
- 3 The VCCI Con C Registration No. is C-3611.

4.1.3 TEST PROCEDURES

- a. The EUT/HOST was placed 0.4 meters from the conducting wall of the shielded room with EUT/HOST being connected to the power mains through a line impedance stabilization network (LISN). Other support units were connected to the power mains through another LISN. The two LISNs provide 50 ohm/ 50uH of coupling impedance for the measuring instrument.
- b. Both lines of the power mains connected to the EUT/HOST were checked for maximum conducted interference.
- c. The frequency range from 150 kHz to 30 MHz was searched. Emission levels over 10dB under the prescribed limits could not be reported

4.1.4 DEVIATION FROM TEST STANDARD

No deviation

4.1.5 TEST SETUP

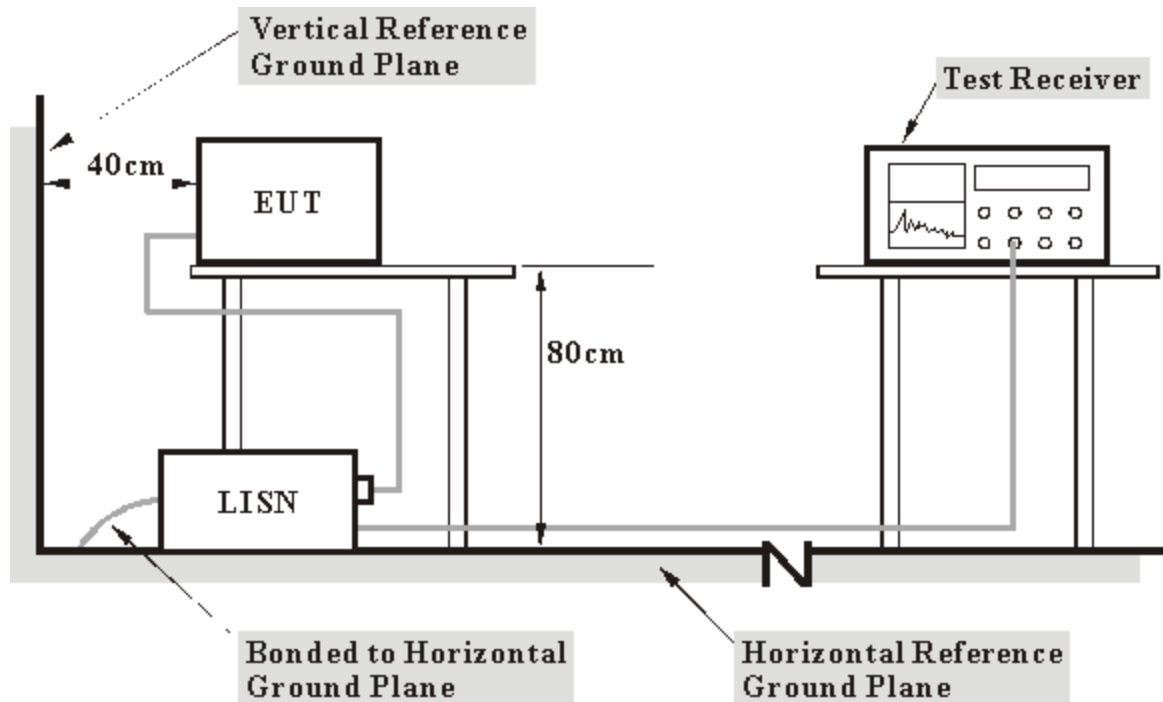

- Note:**
1. Support units were connected to second LISN.
 2. Both of LISNs (AMN) 80 cm from EUT and at the least 80 cm from other units and other metal planes support units.

For the actual test configuration, please refer to the related item – Photographs of the Test Configuration.

4.1.6 EUT OPERATING CONDITIONS

1. Turn on the power of all equipment.
2. Support unit 1 (NB) runs a test program “Runin.exe” to enable of EUT via one USB cable continuously.

4.1.7 TEST RESULTS

INPUT POWER	120Vac, 60 Hz	6DB BANDWIDTH	9 kHz
ENVIRONMENTAL CONDITIONS	20 deg. C, 70%RH	PHASE	Line (L)
TESTED BY	Andy Ho		

No	Freq. [MHz]	Corr. Factor (dB)	Reading Value		Emission Level		Limit		Margin	
			[dB (uV)]		[dB (uV)]		[dB (uV)]		(dB)	
			Q.P.	AV.	Q.P.	AV.	Q.P.	AV.	Q.P.	AV.
1	0.150	0.10	43.13	27.50	43.23	27.60	66.00	56.00	-22.77	-28.40
2	0.224	0.13	34.20	18.72	34.33	18.85	62.66	52.66	-28.33	-33.81
3	3.258	0.19	30.01	24.64	30.20	24.83	56.00	46.00	-25.80	-21.17
4	4.613	0.23	33.31	26.91	33.54	27.14	56.00	46.00	-22.46	-18.86
5	5.688	0.28	32.95	26.54	33.23	26.82	60.00	50.00	-26.77	-23.18
6	16.902	0.60	29.55	22.91	30.15	23.51	60.00	50.00	-29.85	-26.49

- REMARKS:**
1. Q.P. and AV. are abbreviations of quasi-peak and average individually.
 2. The emission levels of other frequencies were very low against the limit.
 3. Margin value = Emission level - Limit value
 4. Correction factor = Insertion loss + Cable loss
 5. Emission Level = Correction Factor + Reading Value.

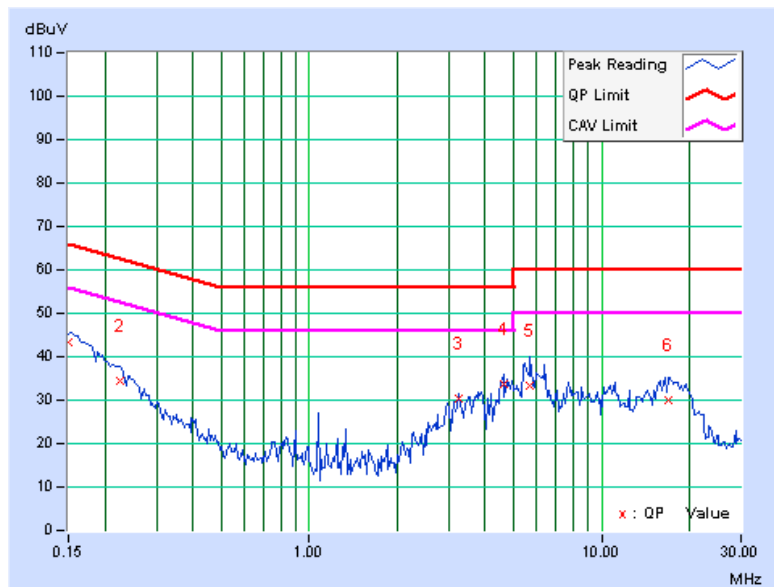

INPUT POWER	120Vac, 60 Hz	6DB BANDWIDTH	9 kHz
ENVIRONMENTAL CONDITIONS	20 deg. C, 70%RH	PHASE	Neutral (N)
TESTED BY	Andy Ho		

No	Freq. [MHz]	Corr. Factor (dB)	Reading Value [dB (uV)]		Emission Level [dB (uV)]		Limit [dB (uV)]		Margin (dB)	
			Q.P.	AV.	Q.P.	AV.	Q.P.	AV.	Q.P.	AV.
1	0.150	0.12	42.81	27.03	42.93	27.15	66.00	56.00	-23.07	-28.85
2	4.762	0.35	33.31	27.70	33.66	28.05	56.00	46.00	-22.34	-17.95
3	5.465	0.41	31.66	25.95	32.07	26.36	60.00	50.00	-27.93	-23.64
4	8.004	0.65	30.08	24.45	30.73	25.10	60.00	50.00	-29.27	-24.90
5	10.996	0.89	28.51	22.72	29.40	23.61	60.00	50.00	-30.60	-26.39
6	17.555	1.27	31.36	24.97	32.63	26.24	60.00	50.00	-27.37	-23.76

- REMARKS:**
1. Q.P. and AV. are abbreviations of quasi-peak and average individually.
 2. The emission levels of other frequencies were very low against the limit.
 3. Margin value = Emission level - Limit value
 4. Correction factor = Insertion loss + Cable loss
 5. Emission Level = Correction Factor + Reading Value.

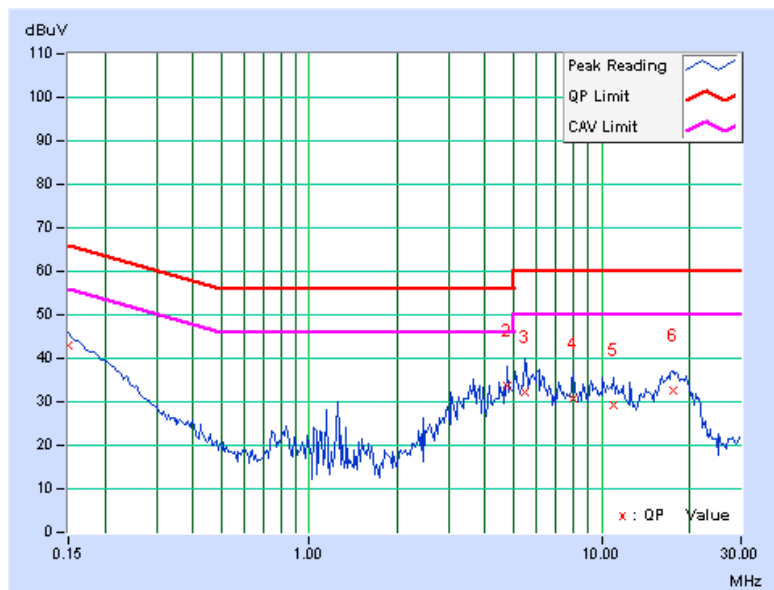

4.2 RADIATED EMISSION & OCCUPIED BANDWIDTH MEASUREMENT

4.2.1 LIMITS OF RADIATED EMISSION MEASUREMENT

According to 15.225(a) the field strength of any emission within the band 13.553-13.567MHz should not exceed 15,848 micro-volts/meter at 30 meters.

Fundamental Frequency (MHz)	Field Strength of Fundamental (dBuV/m) at 10m
13.553-13.567	103.1

Emissions radiated outside of the specified bands, shall be according to the general radiated limits in 15.209 as following:

Frequencies (MHz)	Field strength (microvolts/meter)	Measurement distance (meters)
0.009-0.490	2400/F(kHz)	300
0.490-1.705	24000/F(kHz)	30
1.705-30.0	30	30
30-88	100	3
88-216	150	3
216-960	200	3
Above 960	500	3

As shown in 15.35(b), for frequencies above 1000MHz, the field strength limits are based on average detector, however, the peak field strength of any emission shall not exceed the maximum permitted average limits, specified above by more than 20dB under any condition of modulation.



4.2.2 TEST INSTRUMENTS

For Radiated emission below 30MHz: (Test date: Aug. 15, 2011)

DESCRIPTION & MANUFACTURER	MODEL NO.	SERIAL NO.	CALIBRATED DATE	CALIBRATED UNTIL
ROHDE & SCHWARZ Test Receiver	ESCS 30	100287	Mar. 02, 2011	Mar. 01, 2012
R&S Loop Antenna	HFH2-Z2	100070	Feb. 03, 2011	Feb. 02, 2012
RF Cable	8DFB	CHFCAB-001 CHFCAB-002 CHFCAB-003	Nov. 16, 2010	Nov. 15, 2011
Software	ADT_Radiated_ V8.7.05	NA	NA	NA
CT Antenna Tower & Turn Table	NA	NA	NA	NA

- Note: 1. The calibration interval of the above test instruments is 12 months and the calibrations are traceable to NML/ROC and NIST/USA.
 2. The test was performed in 10m Chamber No. F.
 3. The FCC Site Registration No. is 928149.
 4. The VCCI Site Registration No. is R-3252 & G-136.
 5. The CANADA Site Registration No. is IC 7450H-1.

For Radiated emission 30~1000MHz: (Aug. 18, 2011)

DESCRIPTION & MANUFACTURER	MODEL NO.	SERIAL NO.	CALIBRATED DATE	CALIBRATED UNTIL
Agilent Spectrum Analyzer	E4446A	MY48250254	July 12, 2011	July 11, 2012
Agilent Pre-Selector	N9039A	MY46520311	July 12, 2011	July 11, 2012
Agilent Signal Generator	N5181A	MY49060517	July 12, 2011	July 11, 2012
Mini-Circuits Pre-Amplifier	ZFL-1000VH2B	AMP-ZFL-03	Nov. 16, 2010	Nov. 15, 2011
SCHWARZBECK Trilog Broadband Antenna	VULB 9168	9168-360	Apr. 14, 2011	Apr. 13, 2012
RF CABLE	NA	RF104-201 RF104-203 RF104-204	Dec. 27, 2010	Dec. 26, 2011
RF Cable	NA	CHGCAB_001	NA	NA
Software	ADT_Radiated_ V8.7.05	NA	NA	NA
CT Antenna Tower & Turn Table	NA	NA	NA	NA

- Note: 1. The calibration interval of the above test instruments is 12 months and the calibrations are traceable to NML/ROC and NIST/USA.
 2. The horn antenna, preamplifier (model: 8449B) are used only for the measurement of emission frequency above 1GHz if tested.
 3. The test was performed in 966 Chamber No. G.
 4. The FCC Site Registration No. is 966073.
 5. The VCCI Site Registration No. is G-137.
 6. The CANADA Site Registration No. is IC 7450H-2.

4.2.3 TEST PROCEDURES

For Radiated emission below 30MHz

- a. The EUT was placed on the top of a rotating table 0.8 meters above the ground at a 10 meter chamber room. The table was rotated 360 degrees to determine the position of the highest radiation.
- b. The EUT was set 10 meters away from the interference-receiving antenna, which was mounted on the top of a variable-height antenna tower.
- c. Both X and Y axes of the antenna are set to make the measurement.
- d. For each suspected emission, the EUT was arranged to its worst case and the rotatable table was turned from 0 degrees to 360 degrees to find the maximum reading.
- e. The test-receiver system was set to Quasi-Peak Detect Function and Specified Bandwidth with Maximum Hold Mode.

NOTE:

1. The resolution bandwidth and video bandwidth of test receiver/spectrum analyzer is 9kHz at frequency below 30MHz.

For Radiated emission 30~1000MHz

- a. The EUT was placed on the top of a rotating table 0.8 meters above the ground at a 3 meter chamber room. The table was rotated 360 degrees to determine the position of the highest radiation.
- b. The EUT was set 3 meters away from the interference-receiving antenna, which was mounted on the top of a variable-height antenna tower.
- c. The height of antenna is varied from one meter to four meters above the ground to determine the maximum value of the field strength. Both horizontal and vertical polarizations of the antenna are set to make the measurement.
- d. For each suspected emission, the EUT was arranged to its worst case and then the antenna was tuned to heights from 1 meter to 4 meters and the rotatable table was turned from 0 degrees to 360 degrees to find the maximum reading.
- e. The test-receiver system was set to Quasi-Peak Detect Function and Specified Bandwidth with Maximum Hold Mode.

NOTE:

1. The resolution bandwidth and video bandwidth of test receiver/spectrum analyzer is 120kHz for Quasi-peak detection (QP) at frequency 30MHz ~ 1GHz.



4.2.4 DEVIATION FROM TEST STANDARD

No deviation

4.2.5 TEST SETUP

For Radiated emission below 30MHz

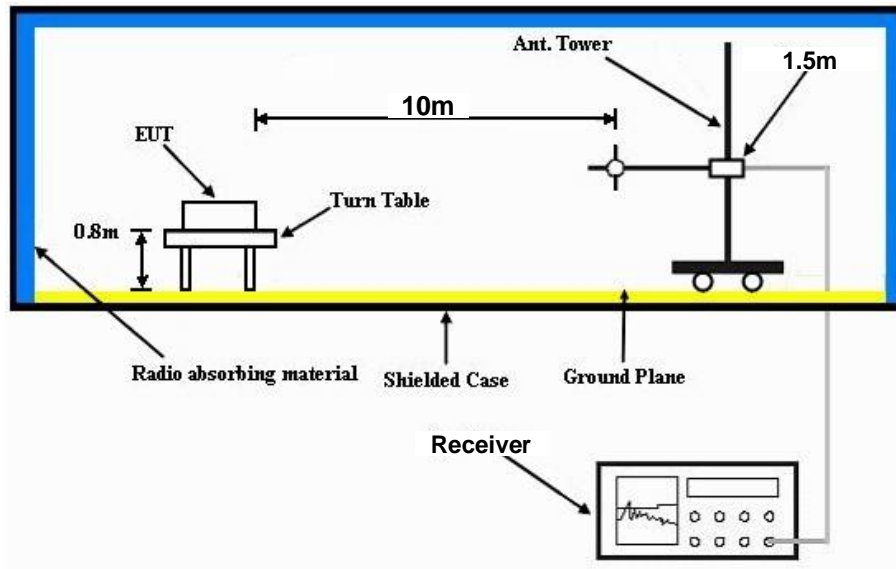

For Radiated emission 30~1000MHz

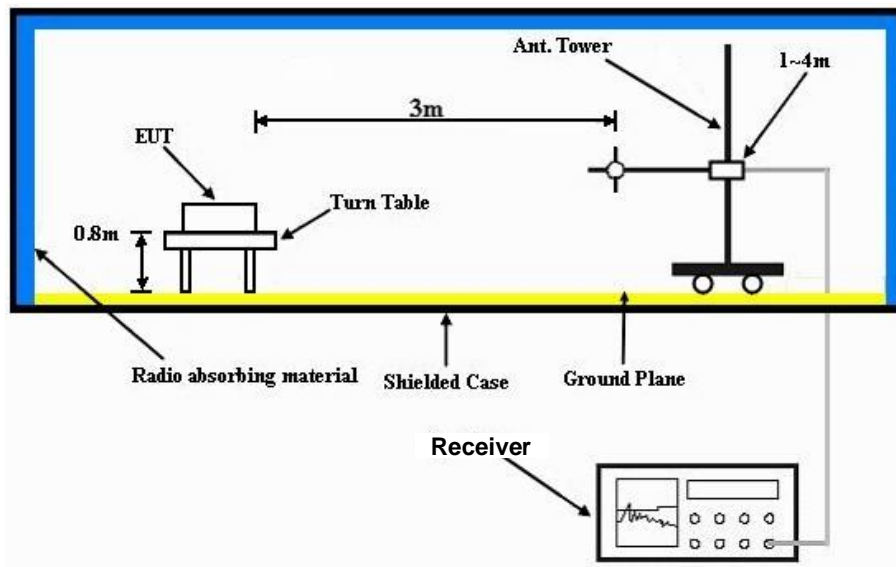

For the actual test configuration, please refer to the related item in this test report - Photographs of the Test Configuration.

4.2.6 EUT OPERATING CONDITIONS

Set the transmitter part of EUT under transmission condition continuously at specific channel frequency.



4.2.7 TEST RESULTS (RADIATED EMISSION BELOW 30MHz)

EUT TEST CONDITION		MEASUREMENT DETAIL	
INPUT POWER	DC 7.4V	FREQUENCY RANGE	9KHz - 30MHz
ENVIRONMENTAL CONDITIONS	25deg. C, 68%RH	DETECTOR FUNCTION	Quasi-Peak (QP)
TESTED BY	Rex Huang		

LOOP ANTENNA TEST DISTANCE: AT 10 M (X AXIS)								
No.	Freq. (MHz)	Emission Level (dBuV/m)	Limit (dBuV/m)	Margin (dB)	Antenna Height (m)	Table Angle (Degree)	Raw Value (dBuV)	Correction Factor (dB/m)
1	*13.56	42.0 QP	103.1	-61.1	1.5	182	42.00	0.00
2	27.12	23.4 QP	48.6	-25.2	1.5	167	23.40	0.00
LOOP ANTENNA TEST DISTANCE: AT 10 M (Y AXIS)								
No.	Freq. (MHz)	Emission Level (dBuV/m)	Limit (dBuV/m)	Margin (dB)	Antenna Height (m)	Table Angle (Degree)	Raw Value (dBuV)	Correction Factor (dB/m)
1	*13.56	53.6 QP	103.1	-49.5	1.5	3	53.60	0.00
2	27.12	23.8 QP	48.6	-24.8	1.5	312	23.80	0.00

- REMARKS:**
1. Emission level(dBuV/m)=Raw Value(dBuV) + Correction Factor(dB/m)
 2. Correction Factor(dB/m) = Antenna Factor (dB/m) + Cable Factor (dB)
 3. The other emission levels were very low against the limit.
 4. Margin value = Emission level – Limit value.
 5. “ * “: Fundamental frequency.



4.2.8 TEST RESULTS (RADIATED EMISSION 30~1000MHz)

EUT TEST CONDITION		MEASUREMENT DETAIL	
INPUT POWER	DC 7.4V	FREQUENCY RANGE	Below 1000MHz
ENVIRONMENTAL CONDITIONS	25deg. C, 70%RH	DETECTOR FUNCTION	Quasi-Peak
TESTED BY	Frank Liu		

ANTENNA POLARITY & TEST DISTANCE: HORIZONTAL AT 3 M								
NO.	FREQ. (MHz)	EMISSION LEVEL (dBuV/m)	LIMIT (dBuV/m)	MARGIN (dB)	ANTENNA HEIGHT (m)	TABLE ANGLE (Degree)	RAW VALUE (dBuV)	CORRECTION FACTOR (dB/m)
1	156.59	40.26 QP	43.50	-3.24	1.50 H	360	25.57	14.69
2	189.99	38.98 QP	43.50	-4.52	1.50 H	242	26.77	12.21
3	196.62	41.42 QP	43.50	-2.08	1.00 H	204	29.77	11.65
4	203.37	39.90 QP	43.50	-3.60	1.00 H	93	28.40	11.50
5	210.00	40.00 QP	43.50	-3.50	1.00 H	0	28.25	11.75
6	336.71	32.67 QP	46.00	-13.33	1.00 H	121	16.59	16.08
ANTENNA POLARITY & TEST DISTANCE: VERTICAL AT 3 M								
NO.	FREQ. (MHz)	EMISSION LEVEL (dBuV/m)	LIMIT (dBuV/m)	MARGIN (dB)	ANTENNA HEIGHT (m)	TABLE ANGLE (Degree)	RAW VALUE (dBuV)	CORRECTION FACTOR (dB/m)
1	136.58	35.47 QP	43.50	-8.03	1.50 V	81	21.45	14.02
2	149.96	35.44 QP	43.50	-8.06	1.00 V	48	20.70	14.74
3	163.34	36.56 QP	43.50	-6.94	1.50 V	117	22.14	14.42
4	216.63	33.47 QP	46.00	-12.53	1.50 V	132	21.47	12.00
5	243.40	33.61 QP	46.00	-12.39	2.00 V	360	20.60	13.01
6	249.91	33.92 QP	46.00	-12.08	2.00 V	360	20.66	13.26

- REMARKS:**
1. Emission level (dBuV/m) = Raw Value (dBuV) + Correction Factor (dB/m).
 2. Correction Factor (dB/m) = Antenna Factor (dB/m) + Cable Factor (dB).
 3. The other emission levels were very low against the limit.
 4. Margin value = Emission level – Limit value.



4.3 OPERATING FREQUENCY MEASUREMENT

4.3.1 TEST INSTRUMENTS

Description & Manufacturer	Model No.	Serial No.	Calibrated DATE	Calibrated Until
R&S Spectrum Analyzer	FSP 40	100060	May 11, 2011	May 10, 2012

NOTE: The calibration interval of the above test instruments is 12 months and the calibrations are traceable to NML/ROC and NIST/USA.

4.3.2 EUT OPERATING CONDITION

Set the transmitter part of EUT under transmission condition continuously at specific channel frequency.

4.3.3 TEST RESULTS

The EUT was operation within the band 13.110-14.010 MHz.

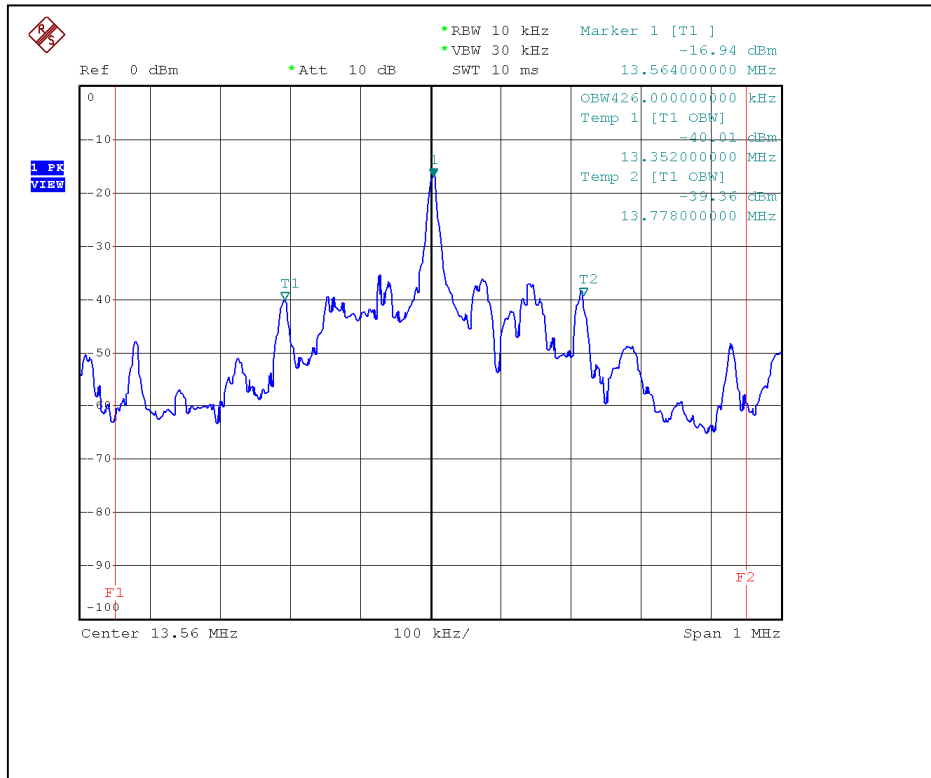



4.4 FREQUENCY STABILITY

4.4.1 LIMITS OF FREQUENCY STABILITY MEASUREMENT

According to FCC 47 CFR Section 15.225(e), the frequency tolerance of the carrier signal shall be maintained within +/- 0.01% of the operating frequency over a temperature variation of -30 degrees to 50 degrees C at normal supply voltage, and for a variation in the primary supply voltage from 85% to 115% of the rated supply voltage at a temperature of 20 degrees C.

4.4.2 TEST INSTRUMENTS

Test date: Sep. 05, 2011

Description & Manufacturer	Model No.	Serial No.	Calibrated DATE	Calibrated Until
R&S Spectrum Analyzer	FSP 40	100060	May 11, 2011	May 10, 2012

NOTE: The calibration interval of the above test instruments is 12 months and the calibrations are traceable to NML/ROC and NIST/USA.

4.4.3 TEST PROCEDURE

1. The EUT was placed inside the environmental test chamber and powered by nominal AC voltage.
2. Turn the EUT on and couple its output to a spectrum analyzer.
3. Turn the EUT off and set the chamber to the highest temperature specified.
4. Allow sufficient time (approximately 30 min) for the temperature of the chamber to stabilize, turn the EUT on and measure the operating frequency after 2, 5, and 10 minutes.
5. Repeat step 2 and 3 with the temperature chamber set to the lowest temperature.
6. The test chamber was allowed to stabilize at +20 degree C for a minimum of 30 minutes. The supply voltage was then adjusted on the EUT from 85% to 115% and the frequency record.

4.4.4 DEVIATION FROM TEST STANDARD

No deviation

4.4.5 TEST SETUP

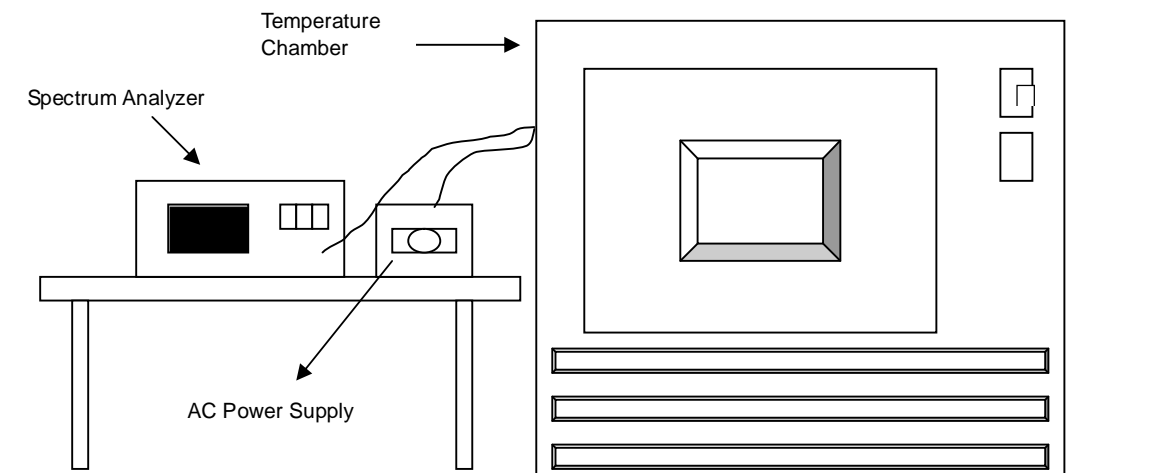

4.4.6 EUT OPERATING CONDITION

The software provided by client to enable the EUT under transmission condition continuously at specific channel frequencies individually.



4.4.7 TEST RESULTS

Operating frequency: 13.56MHz									
Temp. (°C)	Power supply (VAC)	0 minute		2 minute		5 minute		10 minute	
		(MHz)	ppm	(MHz)	ppm	(MHz)	ppm	(MHz)	ppm
50	138	13.559826	-12.8319	13.559797	-14.9705	13.559848	-11.2094	13.559813	-13.7906
	120	13.559841	-11.7257	13.559801	-14.6755	13.55985	-11.0619	13.559802	-14.6018
	102	13.559829	-12.6106	13.559786	-15.7817	13.559846	-11.3569	13.559799	-14.8230
40	138	13.559842	-11.6519	13.559864	-10.0295	13.559848	-11.2094	13.559867	-9.8083
	120	13.559842	-11.6519	13.559864	-10.0295	13.559857	-10.5457	13.55986	-10.3245
	102	13.559846	-11.3569	13.559862	-10.1770	13.559857	-10.5457	13.559865	-9.9558
30	138	13.560006	0.4425	13.560023	1.6962	13.560064	4.7198	13.560076	5.6047
	120	13.560003	0.2212	13.560024	1.7699	13.560067	4.9410	13.560091	6.7109
	102	13.560004	0.2950	13.560018	1.3274	13.56006	4.4248	13.560088	6.4897
20	138	13.559899	-7.4484	13.559924	-5.6047	13.559947	-3.9086	13.559996	-0.2950
	120	13.559899	-7.4484	13.559919	-5.9735	13.559951	-3.6136	13.560003	0.2212
	102	13.559897	-7.5959	13.559914	-6.3422	13.559961	-2.8761	13.559999	-0.0737
10	138	13.559969	-2.2861	13.560013	0.9587	13.560046	3.3923	13.559998	-0.1475
	120	13.559973	-1.9912	13.560007	0.5162	13.560044	3.2448	13.560002	0.1475
	102	13.559984	-1.1799	13.560026	1.9174	13.560049	3.6136	13.56	0.0000
0	138	13.559908	-6.7847	13.559906	-6.9322	13.559913	-6.4159	13.559949	-3.7611
	120	13.559893	-7.8909	13.559898	-7.5221	13.559932	-5.0147	13.559952	-3.5398
	102	13.559898	-7.5221	13.559907	-6.8584	13.559931	-5.0885	13.559954	-3.3923
-10	138	13.560136	10.0295	13.560139	10.2507	13.560132	9.7345	13.560106	7.8171
	120	13.560134	9.8820	13.560133	9.8083	13.560133	9.8083	13.560101	7.4484
	102	13.56013	9.5870	13.560141	10.3982	13.560116	8.5546	13.560103	7.5959
-20	138	13.560038	2.8024	13.560074	5.4572	13.560038	2.8024	13.56	0.0000
	120	13.560055	4.0560	13.560092	6.7847	13.560025	1.8437	13.559997	-0.2212
	102	13.560043	3.1711	13.560075	5.5310	13.560031	2.2861	13.560012	0.8850
-30	138	13.559792	-15.3392	13.559782	-16.0767	13.559805	-14.3805	13.559825	-12.9056
	120	13.559795	-15.1180	13.559789	-15.5605	13.55981	-14.0118	13.559833	-12.3156
	102	13.55979	-15.4867	13.559785	-15.8555	13.559817	-13.4956	13.559823	-13.0531



A D T

5 INFORMATION ON THE TESTING LABORATORIES

We, Bureau Veritas Consumer Products Services (H.K.) Ltd., Taoyuan Branch, were founded in 1988 to provide our best service in EMC, Radio, Telecom and Safety consultation. Our laboratories are accredited and approved according to ISO/IEC 17025.

Copies of accreditation certificates of our laboratories obtained from approval agencies can be downloaded from our web site: www.adt.com.tw/index.5.phtml.
If you have any comments, please feel free to contact us at the following:

Linko EMC/RF Lab:

Tel: 886-2-26052180

Fax: 886-2-26051924

Hsin Chu EMC/RF Lab:

Tel: 886-3-5935343

Fax: 886-3-5935342

Hwa Ya EMC/RF/Safety/Telecom Lab:

Tel: 886-3-3183232

Fax: 886-3-3185050

Email: service.adt@tw.bureauveritas.com

Web Site: www.adt.com.tw

The address and road map of all our labs can be found in our web site also.



A D T

6 APPENDIX-A- MODIFICATIONS RECORDERS FOR ENGINEERING CHANGES TO THE EUT BY THE LAB

No any modifications are made to the EUT by the lab during the test.

--- END ---