



A D T

FCC TEST REPORT (RFID)

REPORT NO.: RF120719E01

MODEL NO.: FD-400GT(SL8081)

FCC ID: MQT-FD400GTSL

RECEIVED: Oct. 04, 2012

TESTED: Oct. 04 to 29, 2012

ISSUED: Nov. 08, 2012

APPLICANT: XAC AUTOMATION CORP.

ADDRESS: 4F, No. 30, INDUSTRY E. RD. IX, SCIENCE-BASED
INDUSTRIAL PARK,HSINCHU,TAIWAN

ISSUED BY: Bureau Veritas Consumer Products Services (H.K.)
Ltd., Taoyuan Branch Hsin Chu Laboratory

LAB ADDRESS : No. 81-1, Lu Liao Keng, 9th Ling, Wu Lung Tsuen,
Chiung Lin Hsiang, Hsin Chu Hsien 307, Taiwan,
R.O.C.

TEST LOCATION (1): No. 81-1, Lu Liao Keng, 9th Ling, Wu Lung Tsuen,
Chiung Lin Hsiang, Hsin Chu Hsien 307, Taiwan,
R.O.C.

TEST LOCATION (2): No. 49, Ln. 206, Wende Rd., Shangshan Tsuen,
Chiung Lin Hsiang, Hsin Chu Hsien 307, Taiwan,
R.O.C.

This report should not be used by the client to claim
product certification, approval, or endorsement by TAF
or any government agencies.



This report is for your exclusive use. Any copying or replication of this report to or for any other person or entity, or use of our name or trademark, is permitted only with our prior written permission. This report sets forth our findings solely with respect to the test samples identified herein. The results set forth in this report are not indicative or representative of the quality or characteristics of the lot from which a test sample was taken or any similar or identical product unless specifically and expressly noted. Our report includes all of the tests requested by you and the results thereof based upon the information that you provided to us. You have 60 days from date of issuance of this report to notify us of any material error or omission caused by our negligence, provided, however, that such notice shall be in writing and shall specifically address the issue you wish to raise. A failure to raise such issue within the prescribed time shall constitute your unqualified acceptance of the completeness of this report, the tests conducted and the correctness of the report contents. Unless specific mention, the uncertainty of measurement has been explicitly taken into account to declare the compliance or non-compliance to the specification



Table of Contents

RELEASE CONTROL RECORD	3
1 CERTIFICATION.....	4
2 SUMMARY OF TEST RESULTS	5
2.1 MEASUREMENT UNCERTAINTY	6
3 GENERAL INFORMATION	7
3.1 GENERAL DESCRIPTION OF EUT	7
3.2 DESCRIPTION OF TEST MODES	8
3.2.1 TEST MODE APPLICABILITY AND TESTED CHANNEL DETAIL.....	9
3.3 GENERAL DESCRIPTION OF APPLIED STANDARDS.....	11
3.4 DESCRIPTION OF SUPPORT UNITS	12
3.5 CONFIGURATION OF SYSTEM UNDER TEST.....	13
4 TEST PROCEDURES AND RESULTS.....	14
4.1 CONDUCTED EMISSION MEASUREMENT.....	14
4.1.1 LIMITS OF CONDUCTED EMISSION MEASUREMENT	14
4.1.2 TEST INSTRUMENTS.....	14
4.1.3 TEST PROCEDURES	15
4.1.4 DEVIATION FROM TEST STANDARD.....	15
4.1.5 TEST SETUP.....	16
4.1.6 EUT OPERATING CONDITIONS	16
4.1.7 TEST RESULTS	17
4.2 RADIATED EMISSION & OCCUPIED BANDWIDTH MEASUREMENT	19
4.2.1 LIMITS OF RADIATED EMISSION MEASUREMENT	19
4.2.2 TEST INSTRUMENTS.....	20
4.2.3 TEST PROCEDURES	22
4.2.4 DEVIATION FROM TEST STANDARD.....	23
4.2.5 TEST SETUP.....	23
4.2.6 EUT OPERATING CONDITIONS	23
4.2.7 TEST RESULTS	24
4.3 20DB BANDWIDTH	28
4.3.1 LIMITS OF 20DB BANDWIDTH MEASUREMENT	28
4.3.2 TEST INSTRUMENTS.....	28
4.3.3 EUT OPERATING CONDITION.....	28
4.3.4 TEST RESULTS	29
4.4 FREQUENCY STABILITY.....	30
4.4.1 LIMITS OF FREQUENCY STABILITY MEASUREMENT	30
4.4.2 TEST INSTRUMENTS.....	30
4.4.3 TEST PROCEDURE.....	30
4.4.4 DEVIATION FROM TEST STANDARD.....	31
4.4.5 TEST SETUP.....	31
4.4.6 EUT OPERATING CONDITION.....	31
4.4.7 TEST RESULTS	32
5 INFORMATION ON THE TESTING LABORATORIES.....	33
6 APPENDIX-A- MODIFICATIONS RECORDERS FOR ENGINEERING CHANGES TO THE EUT BY THE LAB	34



A D T

RELEASE CONTROL RECORD

ISSUE NO.	REASON FOR CHANGE	DATE ISSUED
RF121004E01	Original release	Nov. 08, 2012



A D T

1 CERTIFICATION

PRODUCT : Portable Terminal
BRAND NAME : First Data
MODEL NO. : FD-400GT(SL8081)
TEST SAMPLE : R&D SAMPLE
APPLICANT : XAC AUTOMATION CORP.
TESTED : Oct. 04 to 29, 2012
STANDARDS: FCC Part 15, Subpart C (Section 15.225)
FCC Part 15, Subpart C (Section 15.215)
ANSI C63.10-2009

The above equipment (Model: FD-400GT(SL8081)) has been tested by **Bureau Veritas Consumer Products Services (H.K.) Ltd., Taoyuan Branch**, and found compliance with the requirement of the above standards. The test record, data evaluation & Equipment Under Test (EUT) configurations represented herein are true and accurate accounts of the measurements of the sample's EMC characteristics under the conditions specified in this report.

PREPARED BY : , **DATE:** Nov. 08, 2012
(Claire Kuan, Specialist)

APPROVED BY : , **DATE:** Nov. 08, 2012
(May Chen, Deputy Manager)



2 SUMMARY OF TEST RESULTS

The EUT has been tested according to the following specifications:

APPLIED STANDARD: FCC PART 15, SUBPART C (SECTION 15.225, 15.215)			
STANDARD SECTION	TEST TYPE AND LIMIT	RESULT	REMARK
15.207	Conducted emission test	PASS	Meet the requirement of limit. Minimum passing margin is -26.02dB at 0.16562MHz.
15.225 (a)	The field strength of any emissions within the band 13.553-13.567 MHz	PASS	Meet the requirement of limit. Minimum passing margin is -54.2dB at 13.56MHz
15.225 (d)	The field strength of any emissions appearing outside of the 13.110-14.010 MHz band	PASS	Meet the requirement of limit. Minimum passing margin is -4.0dB at 185.61MHz
15.225 (e)	The frequency tolerance	PASS	Meet the requirement of limit.
15.215 (c)	20dB Bandwidth	PASS	Meet the requirement of limit.



2.1 MEASUREMENT UNCERTAINTY

Where relevant, the following measurement uncertainty levels have been estimated for tests performed on the EUT as specified in CISPR 16-4-2:

This uncertainty represents an expanded uncertainty expressed at approximately the 95% confidence level using a coverage factor of $k=2$.

Measurement	Value
Conducted Emission	2.98 dB
Radiated emissions-Chamber F	4.00 dB
Radiated emissions-Chamber G	5.69 dB

3 GENERAL INFORMATION

3.1 GENERAL DESCRIPTION OF EUT

PRODUCT	Portable Terminal
MODEL NO.	FD-400GT(SL8081)
POWER SUPPLY	DC 12V from adapter or DC7.4V from battery
MODULATION TYPE	ASK
OPERATING FREQUENCY	13.56MHz
NUMBER OF CHANNEL	1
ANTENNA TYPE	Please see NOTE
DATA CABLE	NA
I/O PORTS	Refer to user's manual
ASSOCIATED DEVICES	Adapter x 1, Battery x 1

NOTE:

1. There are RFID, GPRS, E-GPRS, WCDMA, HSDPA and HSUPA technology used for the EUT. and the functions of EUT listed as below table:

Function	Report No.
RFID	RF121004E01
2G & 3G (Part 22)	RF121004E01-1
2G & 3G (Part 24)	RF121004E01-2

2. The emission of the simultaneous operation (RFID & GPRS, E-GPRS, WCDMA, HSDPA and HSUPA) has been evaluated and no non-compliance found.

3. The EUT could be supplied with 7.4V battery or power adapter as the following table:

Item	Brand	Model No.	Spec.
Battery	CHENG UEI PRECISION INDUSTRY CO.,LTD	FD400	DC7.4V, 2300mAh(17.02Wh)
Adapter	DELTA	ADP-36JH B	AC I/P: 100-240V, 50-60Hz, 1.0A AC input cable: Unshielded, 1.85m DC O/P: 12V, 3A DC output cable: Unshielded, 1.8m with one core

4. There are two antennas provided to this EUT, please refer to the following table:

RFID Antenna Spec.					
Brand	Model No.	Antenna Type	Antenna Connector	Gain(dBi)	Frequency range (MHz)
XAC	PCB OSP ANTENNA BOARD FD400 (ROHS)	PCB (2 Layers)	NA	13	13.56
GPRS, EDGE, WCDMA, HSDPA and HSUPA Antenna Spec.					
Brand	Model No.	Antenna Type	Antenna Connector	Gain(dBi)	Frequency range (MHz)
Ethertronics Inc.	T-000084-01	FPCB	NA	1.65	824~894 1850~1990

5. The EUT was pre-tested in chamber under the following modes:

Pre-test Mode	Description
Mode A	Battery mode
Mode B	Adapter mode

From the above modes, the radiated test worst case was found in **Mode A**. Therefore only the test data of the modes were recorded in this report.

6. For a more detailed features description, please refer to the manufacturer's specifications or the User's Manual.

3.2 DESCRIPTION OF TEST MODES

The EUT only has 1 channel.

CHANNEL	FREQUENCY (MHz)
1	13.56

3.2.1 TEST MODE APPLICABILITY AND TESTED CHANNEL DETAIL

EUT CONFIGURE MODE	APPLICABLE TO					DESCRIPTION
	PLC	RE (Below 30MHz)	RE (Above 30MHz)	FS	BW	
1	-	√	√	√	√	Battery mode
2	√	-	-	-	-	Adapter mode

Where **RE**: Radiated Emission **PLC**: Power Line Conducted Emission
FS: Frequency Stability **BW**: 20dB Bandwidth

POWER LINE CONDUCTED EMISSION TEST:

- Pre-Scan has been conducted to determine the worst-case mode from all possible combinations between available modulations and antenna ports (if EUT with antenna diversity architecture).
- Following channel(s) was (were) selected for the final test as listed below.

AVAILABLE CHANNEL	TESTED CHANNEL	MODULATION TYPE
1	1	ASK

RADIATED EMISSION TEST(BELOW 30MHz):

- Pre-Scan has been conducted to determine the worst-case mode from all possible combinations between available modulations antenna ports (if EUT with antenna diversity architecture).
- Following channel(s) was (were) selected for the final test as listed below.

AVAILABLE CHANNEL	TESTED CHANNEL	MODULATION TYPE
1	1	ASK

RADIATED EMISSION TEST(ABOVE 30MHz):

- Pre-Scan has been conducted to determine the worst-case mode from all possible combinations between available modulations antenna ports (if EUT with antenna diversity architecture).
- Following channel(s) was (were) selected for the final test as listed below.

AVAILABLE CHANNEL	TESTED CHANNEL	MODULATION TYPE
1	1	ASK

FREQUENCY STABILITY:

- Pre-Scan has been conducted to determine the worst-case mode from all possible combinations between available modulations and antenna ports (if EUT with antenna diversity architecture).
- Following channel(s) was (were) selected for the final test as listed below.

AVAILABLE CHANNEL	TESTED CHANNEL	MODULATION TYPE
1	1	ASK



20dB BANDWIDTH:

- Pre-Scan has been conducted to determine the worst-case mode from all possible combinations between available modulations, antenna ports (if EUT with antenna diversity architecture).
- Following channel(s) was (were) selected for the final test as listed below.

AVAILABLE CHANNEL	TESTED CHANNEL	MODULATION TYPE
1	1	ASK

TEST CONDITION:

APPLICABLE TO	ENVIRONMENTAL CONDITIONS	INPUT POWER	TESTED BY
PLC	26deg. C, 53%RH	120Vac, 60Hz	JyunChun Lin
RE	23deg. C, 67%RH	7.4Vdc from battery	Robert Cheng
	25deg. C, 67%RH	7.4Vdc from battery	Robert Cheng
BW	25deg. C, 60%RH	7.4Vdc from battery	Robert Cheng
FS	25deg. C, 60%RH	7.4Vdc from battery	Robert Cheng



A D T

3.3 GENERAL DESCRIPTION OF APPLIED STANDARDS

The EUT is a RF product. According to the specifications of the manufacturer, it must comply with the requirements of the following standards:

FCC Part 15, Subpart C (15.225)
FCC Part 15, Subpart C (15.215)
ANSI C63.10-2009

All test items have been performed and recorded as per the above standards.



3.4 DESCRIPTION OF SUPPORT UNITS

The EUT has been tested as an independent unit together with other necessary accessories or support units. The following support units or accessories were used to form a representative test configuration during the tests.

Conducted Emission test					
No.	Product	Brand	Model No.	Serial No.	FCC ID
1	PERSONAL COMPUTER	DELL	DCSCMF	9KKB32S	FCC DoC
2	MONITOR	DELL	E2210Hc	CN-OG337R-64180-97S -OQDS	FCC DoC
3	PRINTER	EPSON	LQ-300+II	G88Y074083	FCC DoC
4	MODEM	ACEEX	1414	0206026778	IFAXDM1414
5	KEYBOARD	DELL	SK-8115	MY-0DJ325-71619-99B- 0476	FCC DoC
6	MOUSE	DELL	MOC5UO	I1401LVG	FCC DoC

Conducted Emission test	
No.	Signal cable description
1	USB cable, 1.1m / USB cable, 1.8m
2	VGA cable, 1.8m with two cores
3	USB cable, shielded, 1.8m
4	RS232 cable, 1.1m
5	USB cable, shielded, 1.8m with one core
6	USB cable, shielded, 1.8m

Note: 1. All power cords of the above support units are unshielded (1.8m).

3.5 CONFIGURATION OF SYSTEM UNDER TEST

For conducted emission test:

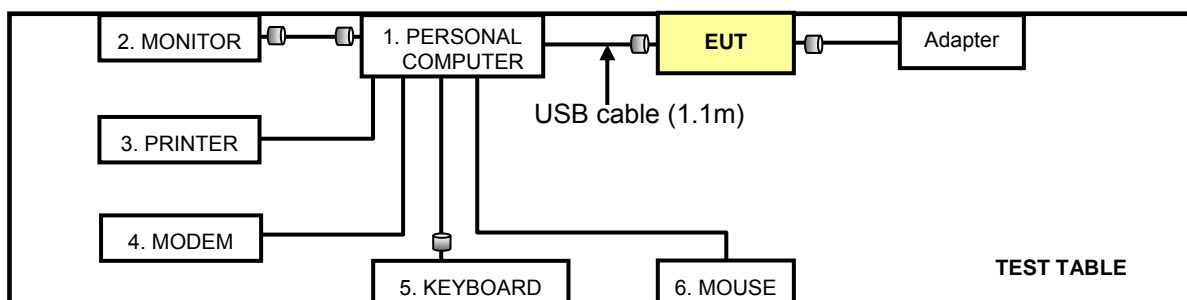

For other test items:

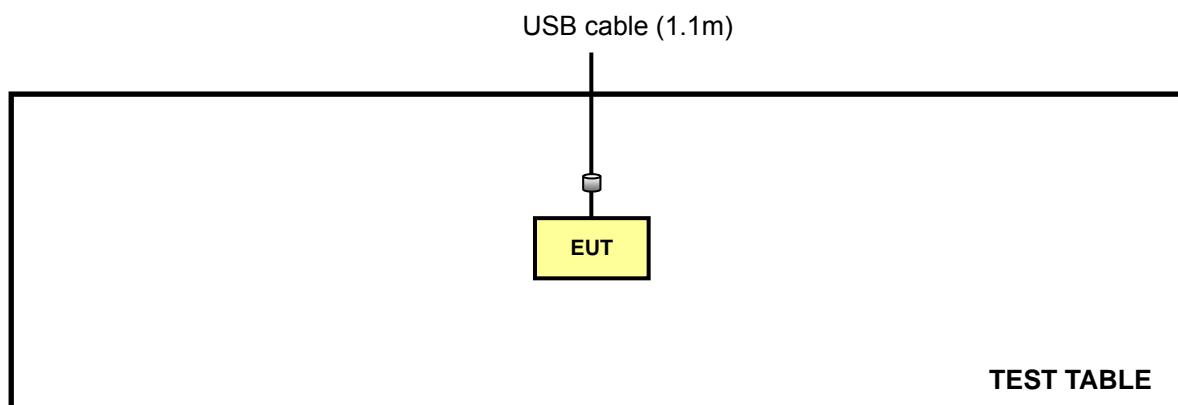



4 TEST PROCEDURES AND RESULTS

4.1 CONDUCTED EMISSION MEASUREMENT

4.1.1 LIMITS OF CONDUCTED EMISSION MEASUREMENT

FREQUENCY OF EMISSION (MHz)	CONDUCTED LIMIT (dBµV)	
0.15-0.5 0.5-5 5-30	Quasi-peak	Average
	66 to 56	56 to 46
	56	46
	60	50

NOTE:

1. The lower limit shall apply at the transition frequencies.
2. All emanations from a class B digital device or system, including any network of conductors and apparatus connected thereto, shall not exceed the level of field strengths specified above.

4.1.2 TEST INSTRUMENTS

DESCRIPTION & MANUFACTURER	MODEL NO.	SERIAL NO.	CALIBRATED DATE	CALIBRATED UNTIL
Test Receiver ROHDE & SCHWARZ	ESCS 30	100287	Feb. 29, 2012	Feb. 28, 2013
Line-Impedance Stabilization Network (for EUT) SCHWARZBECK	NSLK 8127	8127-523	Sep. 19, 2012	Sep. 20, 2013
Line-Impedance Stabilization Network (for Peripheral) ROHDE & SCHWARZ	ESH3-Z5	848773/004	Nov. 01, 2011	Oct. 31, 2012
RF Cable (JYEBAO)	5DFB	COACAB-002	Aug. 05, 2012	Aug. 04, 2013
50 ohms Terminator	50	4	Nov. 12, 2011	Nov. 11, 2012
Software ADT	BV ADT_Cond_V7.3.7 .3	NA	NA	NA

Note:

1. The calibration interval of the above test instruments is 12 months and the calibrations are traceable to NML/ROC and NIST/USA.
2. The test was performed in Shielded Room No. A.
3. The VCCI Con A Registration No. is C-817.
4. Tested Date: Oct. 09, 2012

4.1.3 TEST PROCEDURES

- a. The EUT/HOST was placed 0.4 meters from the conducting wall of the shielded room with EUT/HOST being connected to the power mains through a line impedance stabilization network (LISN). Other support units were connected to the power mains through another LISN. The two LISNs provide 50 ohm/ 50uH of coupling impedance for the measuring instrument.
- b. Both lines of the power mains connected to the EUT/HOST were checked for maximum conducted interference.
- c. The frequency range from 150kHz to 30MHz was searched. Emission levels under (Limit - 20dB) was not recorded.

4.1.4 DEVIATION FROM TEST STANDARD

No deviation

4.1.5 TEST SETUP

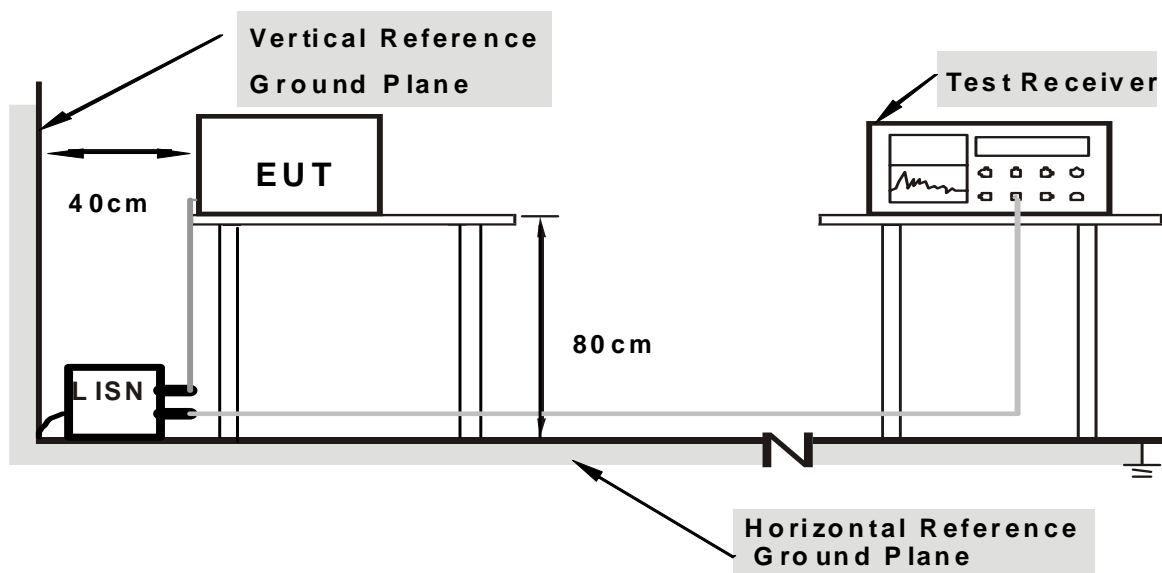

Note: 1. Support units were connected to second LISN.

2. Both of LISNs (AMN) are 80 cm from EUT and at least 80 cm from other units and other metal planes

For the actual test configuration, please refer to the related item – Photographs of the Test Configuration.

4.1.6 EUT OPERATING CONDITIONS

1. Turn on the power of all equipment.
2. The EUT runs a test program “Ptest_D.exe” continuously.

4.1.7 TEST RESULTS

PHASE	Line (L)	6dB BANDWIDTH	9kHz
--------------	----------	----------------------	------

No	Freq.	Corr.	Reading Value		Emission Level		Limit		Margin	
	[MHz]	Factor	[dB (uV)]		[dB (uV)]		[dB (uV)]		(dB)	
		(dB)	Q.P.	AV.	Q.P.	AV.	Q.P.	AV.	Q.P.	AV.
1	0.16562	0.09	45.23	39.89	45.32	39.98	79.00	66.00	-33.68	-26.02
2	0.19297	0.10	40.89	23.82	40.99	23.92	79.00	66.00	-38.01	-42.08
3	0.21641	0.10	37.02	22.86	37.12	22.96	79.00	66.00	-41.88	-43.04
4	0.29453	0.12	26.27	11.85	26.39	11.97	79.00	66.00	-52.61	-54.03
5	0.40781	0.15	22.07	13.08	22.22	13.23	79.00	66.00	-56.78	-52.77
6	15.15625	0.63	17.18	10.53	17.81	11.16	73.00	60.00	-55.19	-48.84

REMARKS:

1. Q.P. and AV. are abbreviations of quasi-peak and average individually.
2. The emission levels of other frequencies were very low against the limit.
3. Margin value = Emission level - Limit value
4. Correction factor = Insertion loss + Cable loss
5. Emission Level = Correction Factor + Reading Value.

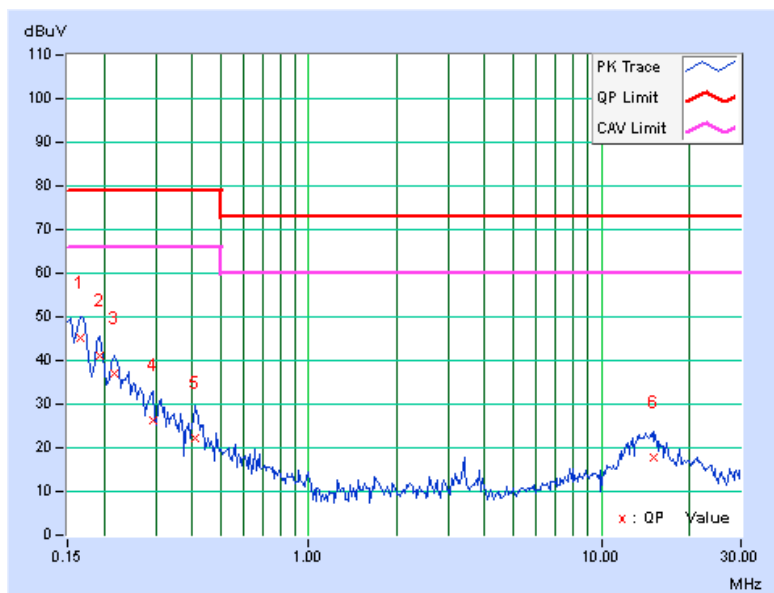

PHASE	Neutral (N)	6dB BANDWIDTH	9kHz
--------------	-------------	----------------------	------

No	Freq.	Corr.	Reading Value		Emission Level		Limit		Margin	
	[MHz]	Factor (dB)	[dB (uV)]		[dB (uV)]		[dB (uV)]		(dB)	
			Q.P.	AV.	Q.P.	AV.	Q.P.	AV.	Q.P.	AV.
1	0.16603	0.10	45.24	39.65	45.34	39.75	79.00	66.00	-33.66	-26.25
2	0.21641	0.11	36.76	19.25	36.87	19.36	79.00	66.00	-42.13	-46.64
3	0.26328	0.13	29.18	12.68	29.31	12.81	79.00	66.00	-49.69	-53.19
4	0.29453	0.13	26.37	11.97	26.50	12.10	79.00	66.00	-52.50	-53.90
5	0.41172	0.16	24.23	14.00	24.39	14.16	79.00	66.00	-54.61	-51.84
6	14.81250	0.61	20.00	11.76	20.61	12.37	73.00	60.00	-52.39	-47.63

REMARKS:

1. Q.P. and AV. are abbreviations of quasi-peak and average individually.
2. The emission levels of other frequencies were very low against the limit.
3. Margin value = Emission level - Limit value
4. Correction factor = Insertion loss + Cable loss
5. Emission Level = Correction Factor + Reading Value.

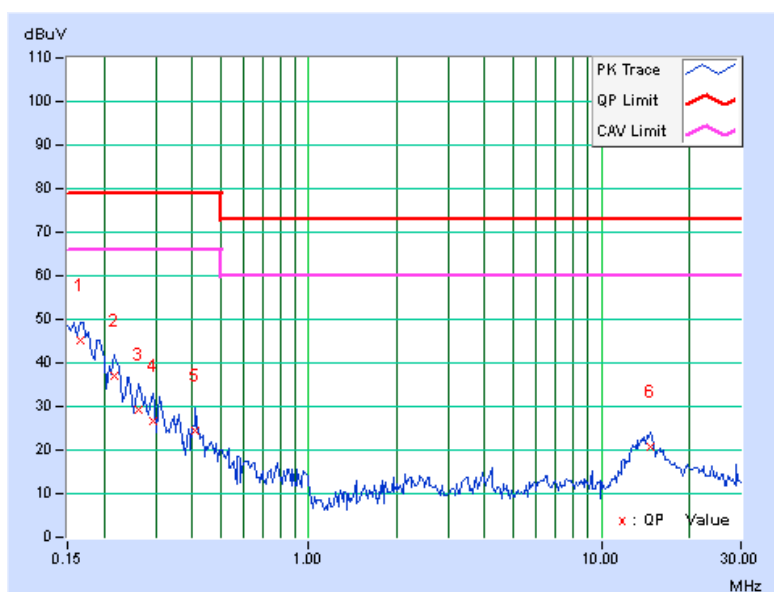

4.2 RADIATED EMISSION & OCCUPIED BANDWIDTH MEASUREMENT

4.2.1 LIMITS OF RADIATED EMISSION MEASUREMENT

The field strength of any emissions within the band 13.553-13.567 MHz shall not exceed 15,848 microvolts/meter at 30 meters.

The field strength of any emissions appearing outside of the 13.110-14.010 MHz band shall not exceed the general radiated emission limits in § 15.209.

FREQUENCIES (MHz)	FIELD STRENGTH (microvolts/meter)	MEASUREMENT DISTANCE (meters)
0.009 ~ 0.490	2400/F(kHz)	300
0.490 ~ 1.705	24000/F(kHz)	30
1.705 ~ 30.0	30	30
30 ~ 88	100	3
88 ~ 216	150	3
216 ~ 960	200	3
Above 960	500	3

NOTE:

1. The lower limit shall apply at the transition frequencies.
2. Emission level (dBuV/m) = 20 log Emission level (uV/m).
3. As shown in 15.35(b), for frequencies above 1000MHz, the field strength limits are based on average detector, however, the peak field strength of any emission shall not exceed the maximum permitted average limits, specified above by more than 20dB under any condition of modulation.



4.2.2 TEST INSTRUMENTS

For below 30MHz:

DESCRIPTION & MANUFACTURER	MODEL NO.	SERIAL NO.	CALIBRATED DATE	CALIBRATED UNTIL
Spectrum Analyzer Agilent	E4443A	MY48250349	July 24, 2012	July 23, 2013
	E4443A	MY49420002	Aug. 10, 2012	Aug. 09, 2013
Pre-Selector Agilent	N9039A	MY46520331	Aug. 10, 2012	Aug. 09, 2013
	N9039A	MY46520309	July 24, 2012	July 23, 2013
Signal Generator Agilent	N5181A	MY49060520	Aug. 10, 2012	Aug. 09, 2013
Pre-Amplifier Mini-Circuits	ZFL-1000VH2B	AMP-ZFL-01	Nov. 15, 2011	Nov. 14, 2012
	ZFL-1000VH2B	AMP-ZFL-02	Nov. 15, 2011	Nov. 14, 2012
Pre-Amplifier Mini-Circuits	ZVA-183-S+	AMP-ZVA-01	Nov. 15, 2011	Nov. 14, 2012
Pre-Amplifier SPACEK LABS	SLKKa-48-6	9K16	Nov. 15, 2011	Nov. 14, 2012
Trilog Broadband Antenna SCHWARZBECK	VULB 9168	9168-359	Apr. 09, 2012	Apr. 08, 2013
	VULB 9168	9168-358	Apr. 06, 2012	Apr. 05, 2013
Spectrum Analyzer Agilent	E4446A	MY48250253	Aug. 28, 2012	Aug. 27, 2013
Horn Antenna SCHWARZBECK	BBHA 9170	9170-424	Oct. 06, 2012	Oct. 05, 2013
Loop Antenna ^(*) R&S	HFH2-Z2	100070	Jan. 31, 2012	Jan. 30, 2014
Test Receiver LIG	ER-265	L09068005	Mar. 14, 2012	Mar. 13, 2013
Pre-Amplifier Agilent	8449B	3008A01975	Mar. 03, 2012	Mar. 02, 2013
Horn Antenna SCHWARZBECK	BBHA 9120	9120D-783	Sep. 20, 2012	Sep. 19, 2013
RF Cable	NA	RF104-110 RF104-206 RF104-209	Dec. 21, 2011	Dec.20, 2012
RF Cable	8DFB	CHFCAB-001 CHFCAB-002 CHFCAB-003	Nov. 15, 2011	Nov. 14, 2012
Software	ADT_Radiated_ V8.7.06	NA	NA	NA
Antenna Tower & Turn Table CT	NA	NA	NA	NA

Note:

1. The calibration interval of the above test instruments is 12 months and the calibrations are traceable to NML/ROC and NIST/USA.
*The calibration interval of the above test instruments is 24 months and the calibrations are traceable to NML/ROC and NIST/USA.
2. The test was performed in 10m Chamber No. F.
3. The FCC Site Registration No. is 928149.
4. The VCCI Site Registration No. is R-3252 & G-136.
5. The CANADA Site Registration No. is IC 7450H-1.
6. Tested Date: Oct. 15, 2012



A D T

For above 30MHz:

DESCRIPTION & MANUFACTURER	MODEL NO.	SERIAL NO.	CALIBRATED DATE	CALIBRATED UNTIL
Spectrum Analyzer Agilent	E4446A	MY48250254	July 09, 2012	July 08, 2013
Pre-Selector Agilent	N9039A	MY46520311	July 09, 2012	July 08, 2013
Signal Generator Agilent	N5181A	MY49060517	July 09, 2012	July 08, 2013
Pre-Amplifier Mini-Circuits	ZFL-1000VH2 B	AMP-ZFL-03	Nov. 15, 2011	Nov. 14, 2012
Pre-Amplifier Agilent	8449B	3008A02578	June 26, 2012	June 25, 2013
Pre-Amplifier SPACEK LABS	SLKka-48-6	9K16	Nov. 15, 2011	Nov. 14, 2012
Trilog Broadband Antenna SCHWARZBECK	VULB 9168	9168-360	Apr. 09, 2012	Apr. 08, 2013
Horn_Antenna AISL	AIH.8018	0000320091110	Nov. 14, 2011	Nov. 13, 2012
Horn_Antenna SCHWARZBECK	BBHA 9170	9170-424	Oct. 07, 2011	Oct. 06, 2012
RF Cable	NA	RF104-201 RF104-203 RF104-204	Dec. 26, 2011	Dec. 25, 2012
RF Cable	NA	CHGCAB_001	Oct. 07, 2011	Oct. 06, 2012
Software	ADT_Radiated _V8.7.05	NA	NA	NA
Antenna Tower & Turn Table CT	NA	NA	NA	NA

Note:

1. The calibration interval of the above test instruments is 12 months and the calibrations are traceable to NML/ROC and NIST/USA.
2. The horn antenna, preamplifier (model: 8449B) are used only for the measurement of emission frequency above 1GHz if tested.
3. The test was performed in 966 Chamber No. G.
4. The FCC Site Registration No. is 966073.
5. The VCCI Site Registration No. is G-137.
6. The CANADA Site Registration No. is IC 7450H-2.
7. Tested Date: Oct. 04, 2012

4.2.3 TEST PROCEDURES

For Radiated emission below 30MHz

- a. The EUT was placed on the top of a rotating table 0.8 meters above the ground at a 10 meter chamber room. The table was rotated 360 degrees to determine the position of the highest radiation.
- b. The EUT was set 10 meters away from the interference-receiving antenna, which was mounted on the top of a variable-height antenna tower.
- c. Both X and Y axes of the antenna are set to make the measurement.
- d. For each suspected emission, the EUT was arranged to its worst case and the rotatable table was turned from 0 degrees to 360 degrees to find the maximum reading.
- e. The test-receiver system was set to Quasi-Peak Detect Function and Specified Bandwidth with Maximum Hold Mode.

NOTE:

1. The resolution bandwidth and video bandwidth of test receiver/spectrum analyzer is 9kHz at frequency below 30MHz.

For Radiated emission 30~1000MHz

- a. The EUT was placed on the top of a rotating table 0.8 meters above the ground at a 3 meter chamber room. The table was rotated 360 degrees to determine the position of the highest radiation.
- b. The EUT was set 3 meters away from the interference-receiving antenna, which was mounted on the top of a variable-height antenna tower.
- c. The height of antenna is varied from one meter to four meters above the ground to determine the maximum value of the field strength. Both horizontal and vertical polarizations of the antenna are set to make the measurement.
- d. For each suspected emission, the EUT was arranged to its worst case and then the antenna was tuned to heights from 1 meter to 4 meters and the rotatable table was turned from 0 degrees to 360 degrees to find the maximum reading.
- e. The test-receiver system was set to Quasi-Peak Detect Function and Specified Bandwidth with Maximum Hold Mode.

NOTE:

1. The resolution bandwidth and video bandwidth of test receiver/spectrum analyzer is 120kHz for Quasi-peak detection (QP) at frequency 30MHz ~ 1GHz.

4.2.4 DEVIATION FROM TEST STANDARD

No deviation

4.2.5 TEST SETUP

For Radiated emission below 30MHz

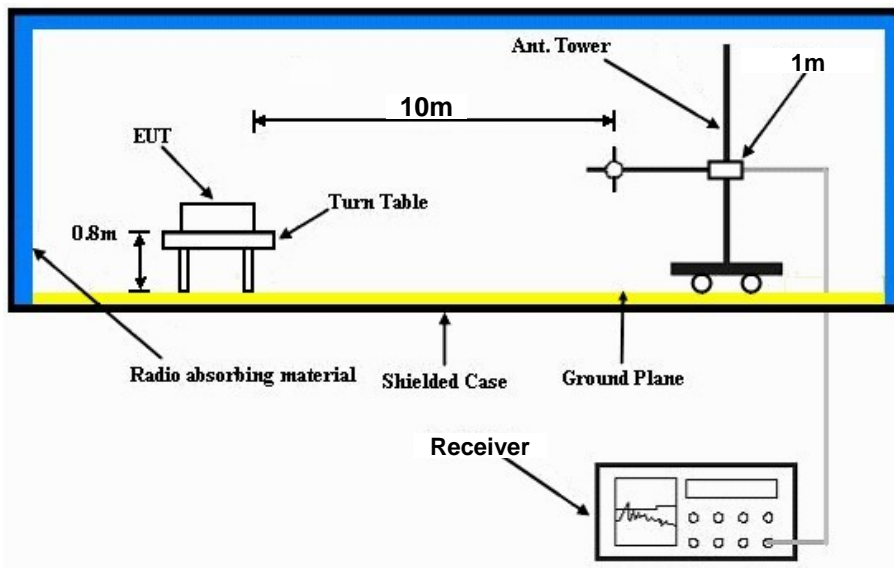

For Radiated emission 30~1000MHz

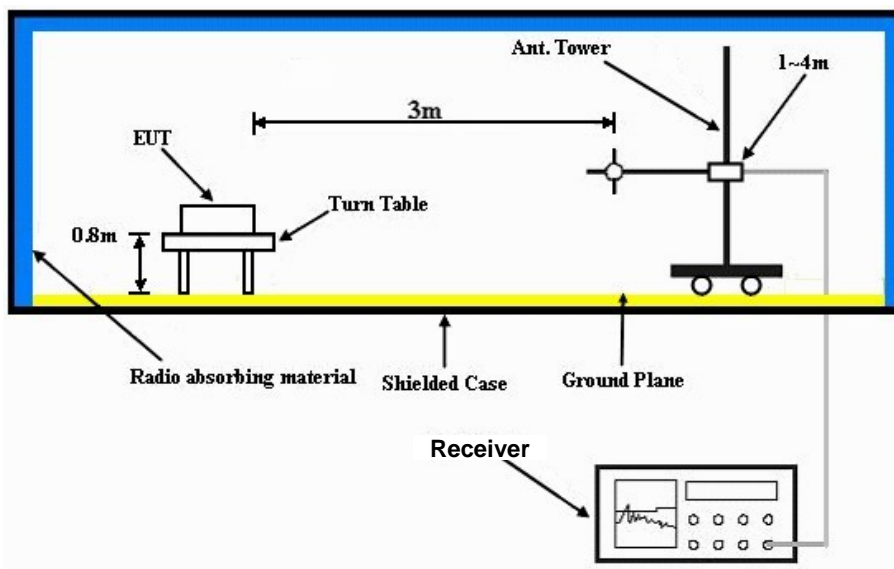

For the actual test configuration, please refer to the related item in this test report - Photographs of the Test Configuration.

4.2.6 EUT OPERATING CONDITIONS

Set the transmitter part of EUT under transmission condition continuously at specific channel frequency.

4.2.7 TEST RESULTS

EUT TEST CONDITION		MEASUREMENT DETAIL	
INPUT POWER	DC 7.4V	FREQUENCY RANGE	13.553 ~ 13.567MHz
ENVIRONMENTAL CONDITIONS	23deg. C, 67%RH	DETECTOR FUNCTION	Quasi-Peak (QP)
TESTED BY	Robert Cheng		

LOOP ANTENNA TEST DISTANCE: AT 10 M (X AXIS)								
No.	Freq. (MHz)	Emission Level (dBuV/m)	Limit (dBuV/m)	Margin (dB)	Antenna Height (m)	Table Angle (Degree)	Raw Value (dBuV)	Correction Factor (dB/m)
1	*13.56	48.9 QP	103.1	-54.2	1.00	0	48.90	0.00

- REMARKS:**
1. Emission level(dBuV/m)=Raw Value(dBuV) + Correction Factor(dB/m)
 2. Correction Factor(dB/m) = Antenna Factor (dB/m) + Cable Factor (dB)
 3. The other emission levels were very low against the limit.
 4. Margin value = Emission level – Limit value.
 5. " * ": Fundamental frequency.

The measured field strength was extrapolated to distance 30 meters, using the formula that the limit of field strength varies as the inverse distance square (40dB per decade of distance)

Example:

$$\begin{aligned}
 13.56\text{MHz} &= 15848\mu\text{V/m} && 30\text{m} \\
 &= 84\text{dBuV/m} && 30\text{m} \\
 &= 84+20\log(30/10)^2 && 10\text{m} \\
 &= 103.1\text{dBuV/m}
 \end{aligned}$$

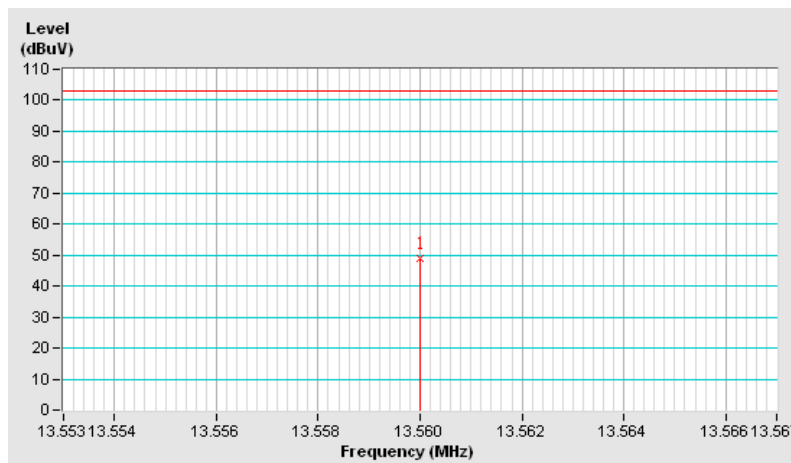



EUT TEST CONDITION		MEASUREMENT DETAIL	
INPUT POWER	DC 7.4V	FREQUENCY RANGE	13.553 ~ 13.567MHz
ENVIRONMENTAL CONDITIONS	23deg. C, 67%RH	DETECTOR FUNCTION	Quasi-Peak (QP)
TESTED BY	Robert Cheng		

LOOP ANTENNA TEST DISTANCE: AT 10 M (Y AXIS)								
No.	Freq. (MHz)	Emission Level (dBuV/m)	Limit (dBuV/m)	Margin (dB)	Antenna Height (m)	Table Angle (Degree)	Raw Value (dBuV)	Correction Factor (dB/m)
1	*13.56	47.6 QP	103.1	-55.5	1.00	0	47.60	0.00

- REMARKS:**
1. Emission level(dBuV/m)=Raw Value(dBuV) + Correction Factor(dB/m)
 2. Correction Factor(dB/m) = Antenna Factor (dB/m) + Cable Factor (dB)
 3. The other emission levels were very low against the limit.
 4. Margin value = Emission level – Limit value.
 5. " * ": Fundamental frequency.

The measured field strength was extrapolated to distance 30 meters, using the formula that the limit of field strength varies as the inverse distance square (40dB per decade of distance)

Example:

$$\begin{aligned}
 13.56\text{MHz} &= 15848\mu\text{V/m} && 30\text{m} \\
 &= 84\text{dBuV/m} && 30\text{m} \\
 &= 84+20\log(30/10)^2 && 10\text{m} \\
 &= 103.1\text{dBuV/m}
 \end{aligned}$$

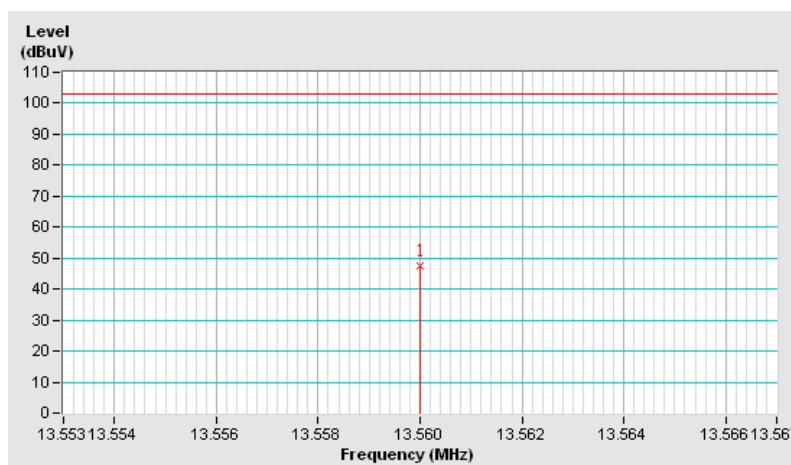



EUT TEST CONDITION		MEASUREMENT DETAIL	
INPUT POWER	DC 7.4V	FREQUENCY RANGE	Below 30MHz
ENVIRONMENTAL CONDITIONS	23deg. C, 67%RH	DETECTOR FUNCTION	Quasi-Peak (QP)
TESTED BY	Robert Cheng		

LOOP ANTENNA TEST DISTANCE: AT 10 M (X AXIS)								
No.	Freq. (MHz)	Emission Level (dBuV/m)	Limit (dBuV/m)	Margin (dB)	Antenna Height (m)	Table Angle (Degree)	Raw Value (dBuV)	Correction Factor (dB/m)
1	0.06	27.8 QP	91.4	-63.6	1.00 H	0	27.8	0.00
2	0.17	21.3 QP	82.4	-61.0	1.00 H	0	21.3	0.00
3	20.04	17.9 QP	48.6	-30.7	1.00 H	0	17.9	0.00

LOOP ANTENNA TEST DISTANCE: AT 10 M (Y AXIS)								
No.	Freq. (MHz)	Emission Level (dBuV/m)	Limit (dBuV/m)	Margin (dB)	Antenna Height (m)	Table Angle (Degree)	Raw Value (dBuV)	Correction Factor (dB/m)
1	0.01	24.7 QP	107.4	-82.7	1.00 V	0	24.7	0.00
2	0.15	22.3 QP	83.2	-60.9	1.00 V	0	22.3	0.00
3	21.36	17.8 QP	48.6	-30.8	1.00 V	0	17.8	0.00

- REMARKS:**
1. Emission level (dBuV/m) = Raw Value (dBuV) + Correction Factor (dB/m).
 2. Correction Factor (dB/m) = Antenna Factor (dB/m) + Cable Factor (dB).
 3. The other emission levels were very low against the limit.
 4. Margin value = Emission level – Limit value.



EUT TEST CONDITION		MEASUREMENT DETAIL	
INPUT POWER	DC 7.4V	FREQUENCY RANGE	Below 1000MHz
ENVIRONMENTAL CONDITIONS	25deg. C, 67%RH	DETECTOR FUNCTION	Quasi-Peak (QP)
TESTED BY	Robert Cheng		

ANTENNA POLARITY & TEST DISTANCE: HORIZONTAL AT 3 M								
NO.	FREQ. (MHz)	EMISSION LEVEL (dBuV/m)	LIMIT (dBuV/m)	MARGIN (dB)	ANTENNA HEIGHT (m)	TABLE ANGLE (Degree)	RAW VALUE (dBuV)	CORRECTION FACTOR (dB/m)
1	119.08	34.4 QP	43.5	-9.2	2.00 H	138	21.90	12.45
2	147.59	33.7 QP	43.5	-9.8	1.50 H	321	18.95	14.75
3	185.61	39.5 QP	43.5	-4.0	1.50 H	200	27.00	12.46
4	195.26	34.3 QP	43.5	-9.3	1.00 H	193	22.66	11.59
5	204.73	35.9 QP	43.5	-7.6	2.00 H	6	24.52	11.37
6	223.81	36.1 QP	46.0	-9.9	2.00 H	360	23.90	12.20
ANTENNA POLARITY & TEST DISTANCE: VERTICAL AT 3 M								
NO.	FREQ. (MHz)	EMISSION LEVEL (dBuV/m)	LIMIT (dBuV/m)	MARGIN (dB)	ANTENNA HEIGHT (m)	TABLE ANGLE (Degree)	RAW VALUE (dBuV)	CORRECTION FACTOR (dB/m)
1	119.05	34.0 QP	43.5	-9.5	1.00 V	306	21.59	12.44
2	138.12	36.3 QP	43.5	-7.2	1.00 V	271	22.53	13.80
3	147.71	35.6 QP	43.5	-7.9	1.00 V	46	20.88	14.76
4	176.25	31.8 QP	43.5	-11.7	1.00 V	293	18.53	13.29
5	242.81	35.2 QP	46.0	-10.8	1.00 V	240	22.16	13.03
6	515.30	31.2 QP	46.0	-14.8	1.50 V	0	10.41	20.75

- REMARKS:**
1. Emission level (dBuV/m) = Raw Value (dBuV) + Correction Factor (dB/m).
 2. Correction Factor (dB/m) = Antenna Factor (dB/m) + Cable Factor (dB).
 3. The other emission levels were very low against the limit.
 4. Margin value = Emission level – Limit value.



4.3 20dB BANDWIDTH

4.3.1 LIMITS OF 20dB BANDWIDTH MEASUREMENT

The 20dB bandwidth shall be specified in operating frequency band.

4.3.2 TEST INSTRUMENTS

DESCRIPTION & MANUFACTURER	MODEL NO.	SERIAL NO.	CALIBRATED DATE	CALIBRATED UNTIL
R&S SPECTRUM ANALYZER	FSP40	100036	Dec. 14, 2011	Dec. 13, 2012

Note:

1. The calibration interval of the above test instruments is 12 months and the calibrations are traceable to NML/ROC and NIST/USA.
2. Tested date : Oct. 26, 2012

4.3.3 EUT OPERATING CONDITION

The bandwidth of the fundamental frequency was measured by spectrum analyzer with 10kHz RBW and 30kHz VBW. The 20dB bandwidth is defined as the total spectrum the power of which is higher than peak power minus 20dB.

4.3.4 TEST RESULTS

20dBc point (Low)	20dBc point (High)	Operating frequency band (MHz)	PASS/FAIL
13.478 MHz	13.712 MHz	13.11 – 14.01	PASS

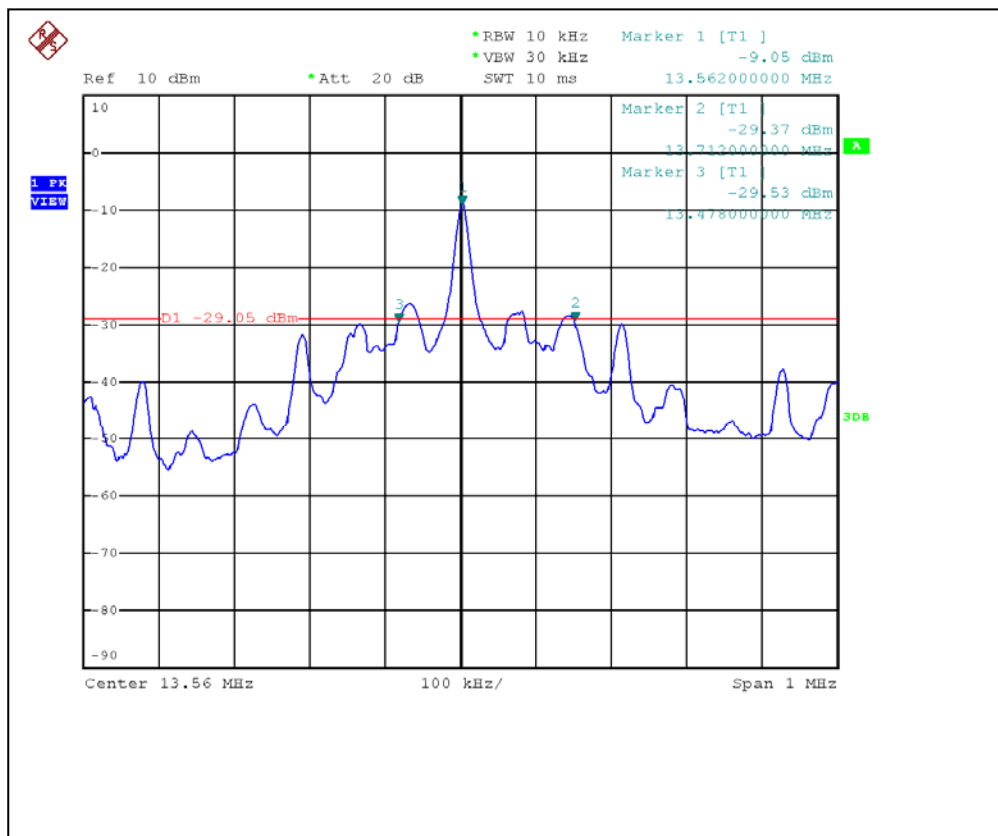



4.4 FREQUENCY STABILITY

4.4.1 LIMITS OF FREQUENCY STABILITY MEASUREMENT

The frequency tolerance of the carrier signal shall be maintained within $\pm 0.01\%$ ($\pm 100\text{ppm}$) of the operating frequency over a temperature variation of -20 degrees to 50 degrees C at normal supply voltage, and for a variation in the primary supply voltage from 85% to 115% of the rated supply voltage at a temperature of 20 degrees C.

4.4.2 TEST INSTRUMENTS

DESCRIPTION & MANUFACTURER	MODEL NO.	SERIAL NO.	CALIBRATED DATE	CALIBRATED UNTIL
R&S SPECTRUM ANALYZER	FSP40	100036	Dec. 14, 2011	Dec. 13, 2012

Note:

1. The calibration interval of the above test instruments is 12 months and the calibrations are traceable to NML/ROC and NIST/USA.
2. Tested date : Oct. 26, 2012

4.4.3 TEST PROCEDURE

1. The EUT was placed inside the environmental test chamber and powered by nominal DC voltage.
2. Turn the EUT on and couple its output to a spectrum analyzer.
3. Turn the EUT off and set the chamber to the highest temperature specified.
4. Allow sufficient time (approximately 30 min) for the temperature of the chamber to stabilize, turn the EUT on and measure the operating frequency after 2, 5, and 10 minutes.
5. Repeat step 2 and 3 with the temperature chamber set to the lowest temperature.
6. The test chamber was allowed to stabilize at $+20$ degree C for a minimum of 30 minutes. The supply voltage was then adjusted on the EUT from 85% to 115% and the frequency record.

4.4.4 DEVIATION FROM TEST STANDARD

No deviation

4.4.5 TEST SETUP

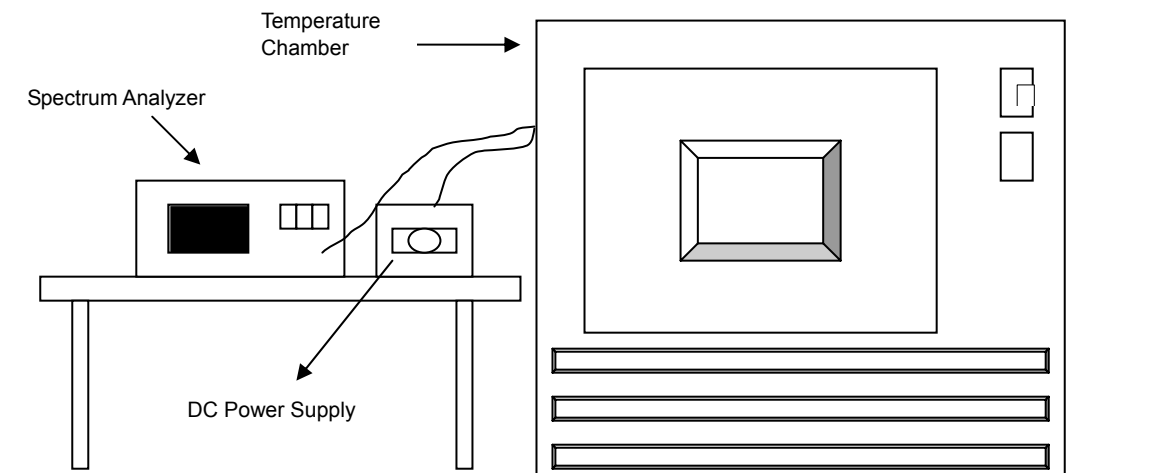

4.4.6 EUT OPERATING CONDITION

The software provided by client to enable the EUT under transmission condition continuously at specific channel frequencies individually.



4.4.7 TEST RESULTS

FREQUENCY STABILITY VERSUS TEMP.									
TEMP. (°C)	POWER SUPPLY (Vdc)	0 MINUTE		2 MINUTE		5 MINUTE		10 MINUTE	
		Measured Frequency	Frequency Drift	Measured Frequency	Frequency Drift	Measured Frequency	Frequency Drift	Measured Frequency	Frequency Drift
		(MHz)	ppm	(MHz)	ppm	(MHz)	ppm	(MHz)	ppm
50	7.4	13.560067	4.9410	13.560022	1.6224	13.559995	-0.3687	13.560005	0.3687
40	7.4	13.559912	-6.4897	13.5599	-7.3746	13.55987	-9.5870	13.55989	-8.1121
30	7.4	13.559988	-0.8850	13.559977	-1.6962	13.559935	-4.7935	13.559879	-8.9233
20	7.4	13.560146	10.7670	13.560095	7.0059	13.560083	6.1209	13.56009	6.6372
10	7.4	13.559954	-3.3923	13.560009	0.6637	13.559999	-0.0737	13.560007	0.5162
0	7.4	13.559824	-12.9794	13.559852	-10.9145	13.55984	-11.7994	13.559821	-13.2006
-10	7.4	13.559942	-4.2773	13.559997	-0.2212	13.559966	-2.5074	13.55995	-3.6873
-20	7.4	13.559863	-10.1032	13.55985	-11.0619	13.559871	-9.5133	13.559835	-12.1681
-30	7.4	13.560179	13.2006	13.560213	15.7080	13.560176	12.9794	13.560178	13.1268

FREQUENCY STABILITY VERSUS VOLTAGE									
TEMP. (°C)	POWER SUPPLY (Vac)	0 MINUTE		2 MINUTE		5 MINUTE		10 MINUTE	
		Measured Frequency	Frequency Drift	Measured Frequency	Frequency Drift	Measured Frequency	Frequency Drift	Measured Frequency	Frequency Drift
		(MHz)	ppm	(MHz)	ppm	(MHz)	ppm	(MHz)	ppm
20	8.51	13.560135	9.9558	13.560098	7.2271	13.560093	6.8584	13.560108	7.9646
	7.4	13.560146	10.7670	13.560095	7.0059	13.560083	6.1209	13.56009	6.6372
	6.29	13.560147	10.8407	13.560093	6.8584	13.560085	6.2684	13.560094	6.9322



A D T

5 INFORMATION ON THE TESTING LABORATORIES

We, Bureau Veritas Consumer Products Services (H.K.) Ltd., Taoyuan Branch, were founded in 1988 to provide our best service in EMC, Radio, Telecom and Safety consultation. Our laboratories are accredited and approved according to ISO/IEC 17025.

If you have any comments, please feel free to contact us at the following:

Linko EMC/RF Lab:

Tel: 886-2-26052180

Fax: 886-2-26051924

Hsin Chu EMC/RF Lab:

Tel: 886-3-5935343

Fax: 886-3-5935342

Hwa Ya EMC/RF/Safety/Telecom Lab:

Tel: 886-3-3183232

Fax: 886-3-3270892

Email: service.adt@tw.bureauveritas.com

Web Site: www.bureauveritas-adt.com

The address and road map of all our labs can be found in our web site also.



A D T

6 APPENDIX-A- MODIFICATIONS RECORDERS FOR ENGINEERING CHANGES TO THE EUT BY THE LAB

No any modifications are made to the EUT by the lab during the test.

--- END ---