

FCC Test Report (PART 24)

Report No.: RF200630E05-6

FCC ID: MQT-AT150R6

Test Model: xCL_AT-150-R6-18U

Received Date: June 22, 2020

Test Date: June 22 to July 19, 2020

Issued Date: Oct. 21, 2020

Applicant: XAC AUTOMATION CORP.

Address: 4F, No. 30, INDUSTRY E. RD. IX, SCIENCE-BASED INDUSTRIAL
PARK,HSINCHU,TAIWAN

Issued By: Bureau Veritas Consumer Products Services (H.K.) Ltd., Taoyuan Branch
Hsin Chu Laboratory

Lab Address: E-2, No.1, Li Hsin 1st Road, Hsinchu Science Park, Hsinchu City 300,
Taiwan

Test Location: E-2, No.1, Li Hsin 1st Road, Hsinchu Science Park, Hsinchu City 300,
Taiwan

**FCC Registration /
Designation Number:** 723255 / TW2022



This report is for your exclusive use. Any copying or replication of this report to or for any other person or entity, or use of our name or trademark, is permitted only with our prior written permission. This report sets forth our findings solely with respect to the test samples identified herein. The results set forth in this report are not indicative or representative of the quality or characteristics of the lot from which a test sample was taken or any similar or identical product unless specifically and expressly noted. Our report includes all of the tests requested by you and the results thereof based upon the information that you provided to us. You have 60 days from date of issuance of this report to notify us of any material error or omission caused by our negligence, provided, however, that such notice shall be in writing and shall specifically address the issue you wish to raise. A failure to raise such issue within the prescribed time shall constitute your unqualified acceptance of the completeness of this report, the tests conducted and the correctness of the report contents. Unless specific mention, the uncertainty of measurement has been explicitly taken into account to declare the compliance or non-compliance to the specification.

Table of Contents

Release Control Record	4
1 Certificate of Conformity	5
2 Summary of Test Results	6
2.1 Measurement Uncertainty	6
2.2 Test Site and Instruments	7
3 General Information	9
3.1 General Description of EUT	9
3.2 Configuration of System under Test	12
3.2.1 Description of Support Units	13
3.3 Test Mode Applicability and Tested Channel Detail	14
3.4 EUT Operating Conditions	15
3.5 General Description of Applied Standards and references	16
4 Test Types and Results	17
4.1 Output Power Measurement	17
4.1.1 Limits of Output Power Measurement	17
4.1.2 Test Procedures	17
4.1.3 Test Setup	17
4.1.4 Test Results	18
4.2 Modulation Characteristics Measurement	23
4.2.1 Limits of Modulation Characteristics	23
4.2.2 Test Procedure	23
4.2.3 Test Setup	23
4.2.4 Test Results	24
4.3 Frequency Stability Measurement	25
4.3.1 Limits of Frequency Stability Measurement	25
4.3.2 Test Procedure	25
4.3.3 Test Setup	25
4.3.4 Test Results	26
4.4 Occupied Bandwidth Measurement	28
4.4.1 Test Procedure	28
4.4.2 Test Setup	28
4.4.3 Test Result (-26dB Bandwidth)	29
4.4.4 Test Result (Occupied Bandwidth)	32
4.5 Band Edge Measurement	35
4.5.1 Limits of Band Edge Measurement	35
4.5.2 Test Setup	35
4.5.3 Test Procedures	35
4.5.4 Test Results	36
4.6 Peak to Average Ratio	43
4.6.1 Limits of Peak to Average Ratio Measurement	43
4.6.2 Test Setup	43
4.6.3 Test Procedures	43
4.6.4 Test Results	44
4.7 Conducted Spurious Emissions	47
4.7.1 Limits of Conducted Spurious Emissions Measurement	47
4.7.2 Test Setup	47
4.7.3 Test Procedure	47
4.7.4 Test Results	48
4.8 Radiated Emission Measurement	69
4.8.1 Limits of Radiated Emission Measurement	69
4.8.2 Test Procedure	69
4.8.3 Deviation from Test Standard	69
4.8.4 Test Setup	70

4.8.5 Test Results	71
5 Pictures of Test Arrangements.....	113
Appendix – Information of the Testing Laboratories	114

Release Control Record

Issue No.	Description	Date Issued
RF200630E05-6	Original release.	Oct. 21, 2020

1 Certificate of Conformity

Product: Terminal

Brand: XAC

Test Model: xCL_AT-150-R6-18U

Sample Status: ENGINEERING SAMPLE

Applicant: XAC AUTOMATION CORP.

Test Date: June 22 to July 19, 2020

Standards: FCC Part 24 Subpart E

The above equipment has been tested by **Bureau Veritas Consumer Products Services (H.K.) Ltd., Taoyuan Branch**, and found compliance with the requirement of the above standards. The test record, data evaluation & Equipment Under Test (EUT) configurations represented herein are true and accurate accounts of the measurements of the sample's EMC characteristics under the conditions specified in this report.

Prepared by :  _____, **Date:** _____ Oct. 21, 2020
Claire Kuan / Specialist

Approved by :  _____, **Date:** _____ Oct. 21, 2020
Clark Lin / Technical Manager

2 Summary of Test Results

Applied Standard: FCC Part 24 & Part 2			
FCC Clause	Test Item	Result	Remarks
2.1046 24.232	Equivalent Isotropically Radiated Power	PASS	Meet the requirement of limit.
2.1046 24.232(d)	Peak To Average Ratio	PASS	Meet the requirement of limit.
2.1047	Modulation characteristics	PASS	Meet the requirement
2.1055 24.235	Frequency Stability	PASS	Meet the requirement of limit.
2.1049 24.238(b)	Occupied Bandwidth	PASS	Meet the requirement of limit.
24.238(b)	Band Edge Measurements	PASS	Meet the requirement of limit.
2.1051 24.238	Conducted Spurious Emissions	PASS	Meet the requirement of limit.
2.1053 24.238	Radiated Spurious Emissions	PASS	Meet the requirement of limit. Minimum passing margin is -28.03 dB at 3760 MHz.

Note: Determining compliance based on the results of the compliance measurement, not taking into account measurement instrumentation uncertainty.

2.1 Measurement Uncertainty

Where relevant, the following measurement uncertainty levels have been estimated for tests performed on the EUT as specified in CISPR 16-4-2:

Measurement	Frequency	Expanded Uncertainty (k=2) (\pm)
Radiated Emissions up to 1 GHz	9kHz ~ 30MHz	3.1 dB
	30MHz ~ 1GHz	5.1 dB
Radiated Emissions above 1 GHz	1GHz ~ 18GHz	5.1 dB
	18GHz ~ 40GHz	5.3 dB

2.2 Test Site and Instruments

For radiated spurious emissions test:

DESCRIPTION & MANUFACTURER	MODEL NO.	SERIAL NO.	CALIBRATED DATE	CALIBRATED UNTIL
Test Receiver R&S	ESR7	102026	Apr. 22, 2020	Apr. 21, 2021
Spectrum Analyzer Keysight	N9030B	MY57141948	May 22, 2020	May 21, 2021
Pre-Amplifier EMCI	EMC001340	980142	May 25, 2020	May 24, 2021
Loop Antenna Electro-Metrics	EM-6879	264	Feb. 18, 2020	Feb. 17, 2021
RF Cable	NA	LOOPCAB-001	Jan. 08, 2020	Jan. 07, 2021
RF Cable	NA	LOOPCAB-002	Jan. 08, 2020	Jan. 07, 2021
Pre-Amplifier EMCI	EMC330N	980538	Apr. 28, 2020	Apr. 27, 2021
Trilog Broadband Antenna SCHWARZBECK	VULB9168	9168-0842	Nov. 08, 2019	Nov. 07, 2020
RF Cable	8D	966-5-1	Apr. 29, 2020	Apr. 28, 2021
RF Cable	8D	966-5-2	Apr. 29, 2020	Apr. 28, 2021
RF Cable	8D	966-5-3	Apr. 29, 2020	Apr. 28, 2021
Fixed attenuator Mini-Circuits	UNAT-5+	PAD-ATT5-02	Jan. 14, 2020	Jan. 13, 2021
Horn_Antenna SCHWARZBECK	BBHA 9120D	9120D-1819	Nov. 24, 2019	Nov. 23, 2020
Pre-Amplifier EMCI	EMC12630SE	980509	Apr. 29, 2020	Apr. 28, 2021
RF Cable EMCI	EMC104-SM-SM-1500	180503	Apr. 29, 2020	Apr. 28, 2021
RF Cable EMCI	EMC104-SM-SM-2000	180501	Apr. 29, 2020	Apr. 28, 2021
RF Cable EMCI	EMC104-SM-SM-6000	180506	Apr. 29, 2020	Apr. 28, 2021
Pre-Amplifier EMCI	EMC184045SE	980387	Jan. 15, 2020	Jan. 14, 2021
Horn_Antenna SCHWARZBECK	BBHA 9170	BBHA9170519	Nov. 24, 2019	Nov. 23, 2020
RF Cable	EMC102-KM-KM-1200	160924	Jan. 15, 2020	Jan. 14, 2021
RF Cable	EMC-KM-KM-4000	200214	Mar. 11, 2020	Mar. 10, 2021
Software	ADT_Radiated_V8.7.08	NA	NA	NA
Boresight Antenna Tower & Turn Table Max-Full	MF-7802BS	MF780208530	NA	NA

Note:

1. The calibration interval of the above test instruments is 12 months and the calibrations are traceable to NML/ROC and NIST/USA.
2. The test was performed in 966 Chamber No. 5.
3. Tested Date: June 22 to July 10, 2020

For other test items:

DESCRIPTION & MANUFACTURER	MODEL NO.	SERIAL NO.	CALIBRATED DATE	CALIBRATED UNTIL
Spectrum Analyzer R&S	FSV40	100964	May 29, 2020	May 28, 2021
Spectrum Analyzer Keysight	N9030A	MY54490679	July 13, 2020	July 12, 2021
Power meter Anritsu	ML2495A	1529002	July 26, 2019	July 25, 2020
Power sensor Anritsu	MA2411B	1339443	July 26, 2019	July 25, 2020
Fixed Attenuator Mini-Circuits	MDCS18N-10	MDCS18N-10-01	Apr. 14, 2020	Apr. 13, 2021
Mech Switch Absorptive Mini-Circuits	MSP4TA-18+	0140	Feb. 10, 2020	Feb. 09, 2021
FXD ATTEN Mini-Circuits	BW-S3W2+	MN71981	Feb. 10, 2020	Feb. 09, 2021
Software	ADT_RF Test Software V6.6.5.4	NA	NA	NA

- Note:**
1. The test was performed in Oven room 2.
 2. The calibration interval of the above test instruments is 12 months and the calibrations are traceable to NML/ROC and NIST/USA.
 3. Tested Date: July 19, 2020

3 General Information

3.1 General Description of EUT

Product	Terminal	
Brand	XAC	
Test Model	xCL_AT-150-R6-18U	
Status of EUT	ENGINEERING SAMPLE	
Power Supply Rating	Refer to note	
Modulation Type	WCDMA, HSDPA, HSUPA	BPSK
	LTE Band 2	QPSK, 16QAM
Operating Frequency	WCDMA, HSDPA, HSUPA	1852.4 MHz ~ 1907.6 MHz
	LTE Band 2	1850.7 MHz ~ 1909.3 MHz
Max. EIRP Power	WCDMA B2	24.84 dBm
	LTE Band 2 (Channel Bandwidth 1.4MHz)	24.87 dBm
	LTE Band 2 (Channel Bandwidth 3MHz)	24.91 dBm
	LTE Band 2 (Channel Bandwidth 5MHz)	24.96 dBm
	LTE Band 2 (Channel Bandwidth 10MHz)	25.00 dBm
	LTE Band 2 (Channel Bandwidth 15MHz)	25.05 dBm
	LTE Band 2 (Channel Bandwidth 20MHz)	25.08 dBm
Emission Designator	WCDMA B2	4M17F9W
	LTE Band 2 (Channel Bandwidth 1.4MHz)	QPSK: 1M08G7D 16QAM: 1M08D7W
	LTE Band 2 (Channel Bandwidth 3MHz)	QPSK: 2M69G7D 16QAM: 2M68D7W
	LTE Band 2 (Channel Bandwidth 5MHz)	QPSK: 4M49G7D 16QAM: 4M48D7W
	LTE Band 2 (Channel Bandwidth 10MHz)	QPSK: 8M96G7D 16QAM: 8M96D7W
	LTE Band 2 (Channel Bandwidth 15MHz)	QPSK: 13M4G7D 16QAM: 13M4D7W
	LTE Band 2 (Channel Bandwidth 20MHz)	QPSK: 18M0G7D 16QAM: 17M9D7W
Antenna Type	Refer to Note	
Antenna Connector	Refer to Note	
Accessory Device	Battery (option) x1	
Data Cable Supplied	NA	

Note:

1. The EUT has three radios as following table:

Radio 1	Radio 2	Radio 3
WLAN(2.4GHz + 5GHz) + Bluetooth	WWAN(LTE + WCDMA)	NFC

2. Simultaneously transmission condition.

Condition	Technology	
1	WWAN	NFC
2	WWAN	Bluetooth
3	WLAN 2.4GHz	NFC
4	WLAN 5GHz	NFC
5	Bluetooth	NFC

Note: The emission of the simultaneous operation has been evaluated and no non-compliance was found.

3. The EUT power needs to be supplied from a power adapter and battery, the information is as below table:

Adapter (only for test, not for sale)		
Brand	Model No.	Spec.
DEE VAN ENTERPRISE CO., LTD	DSA-18PFCA-05 050300	Input: 100-240Vac, 0.6A, 50/60Hz Output: 5Vdc, 3A
Battery (option)		
Brand	Model No.	Spec.
Shenzhen Rishengzhi Electronics Technology Co., Ltd.	W001	Output: 3.6V, 6700mAh, 24.12Wh

4. The antennas provided to the EUT, please refer to the following table:

Antenna Set.	RF Chain No.	Brand	Model	Antenna Net Gain(dBi)	Frequency range	Antenna Type	Connector Type				
NFC	Main	XAC	RTOS	13	13.56MHz	wire	None				
Wi-Fi BT	Main	AWAN	AYF6P-100002	2.29	2400MHz~2500MHz	PIFA	i-pex(MHF)				
				2.77	5150MHz~5850MHz						
LTE	Main(B2) TX	AWAN	AXF6P-100012	2.65	1850 MHz to 1910 MHz	PIFA	i-pex(MHF)				
	Main(B4) TX			2.3	1710 MHz to 1755 MHz						
	Main(B12) TX			2.6	699 MHz to 715 MHz						
	Main(B2) RX			1.66	1930 MHz to 1990 MHz						
	Main(B4) RX			2.05	2110 MHz to 2155 MHz						
	Main(B12) RX			2.52	729 MHz to 745 MHz						
	Aux(B2) RX	AWAN	AXF6P-100005	-4.99	1930 MHz to 1990 MHz	PIFA	i-pex(MHF)				
	Aux(B4) RX			-3.34	2110 MHz to 2155 MHz						
	Aux(B12) RX			-0.32	729 MHz to 746 MHz						
WCDMA	Main(B2) TX	AWAN	AXF6P-100012	2.65	1850 MHz to 1910 MHz	PIFA	i-pex(MHF)				
	Main(B5) TX			2.06	824 MHz to 849 MHz						
	Main(B2) RX			1.66	1930 MHz to 1990 MHz						
	Main(B5) RX			2.8	869 MHz to 894 MHz						
	Aux(B2) RX			AWAN	AXF6P-100005			-4.99	1930 MHz to 1990 MHz	PIFA	i-pex(MHF)
	Aux(B5) RX							-3.54	869 MHz to 894 MHz		
GPS	Main	YAGEO	ANT8010JLD2B151	3.29	1575.42MHz	Chip	i-pex(MHF)				

5. The EUT was pre-tested for radiated emission test under following test modes:

Pre-test Mode	Power
Mode A	Power from Adapter
Mode B	Power from Battery

From the above modes, the worst radiated test was found in **Mode A**.

6. The above EUT information is declared by manufacturer and for more detailed features description, please refer to the manufacturer's specifications or User's Manual.
7. The above Antenna information is declared by manufacturer and for more detailed features description, please refer to the manufacturer's specifications, the laboratory shall not be held responsible.

3.2 Configuration of System under Test

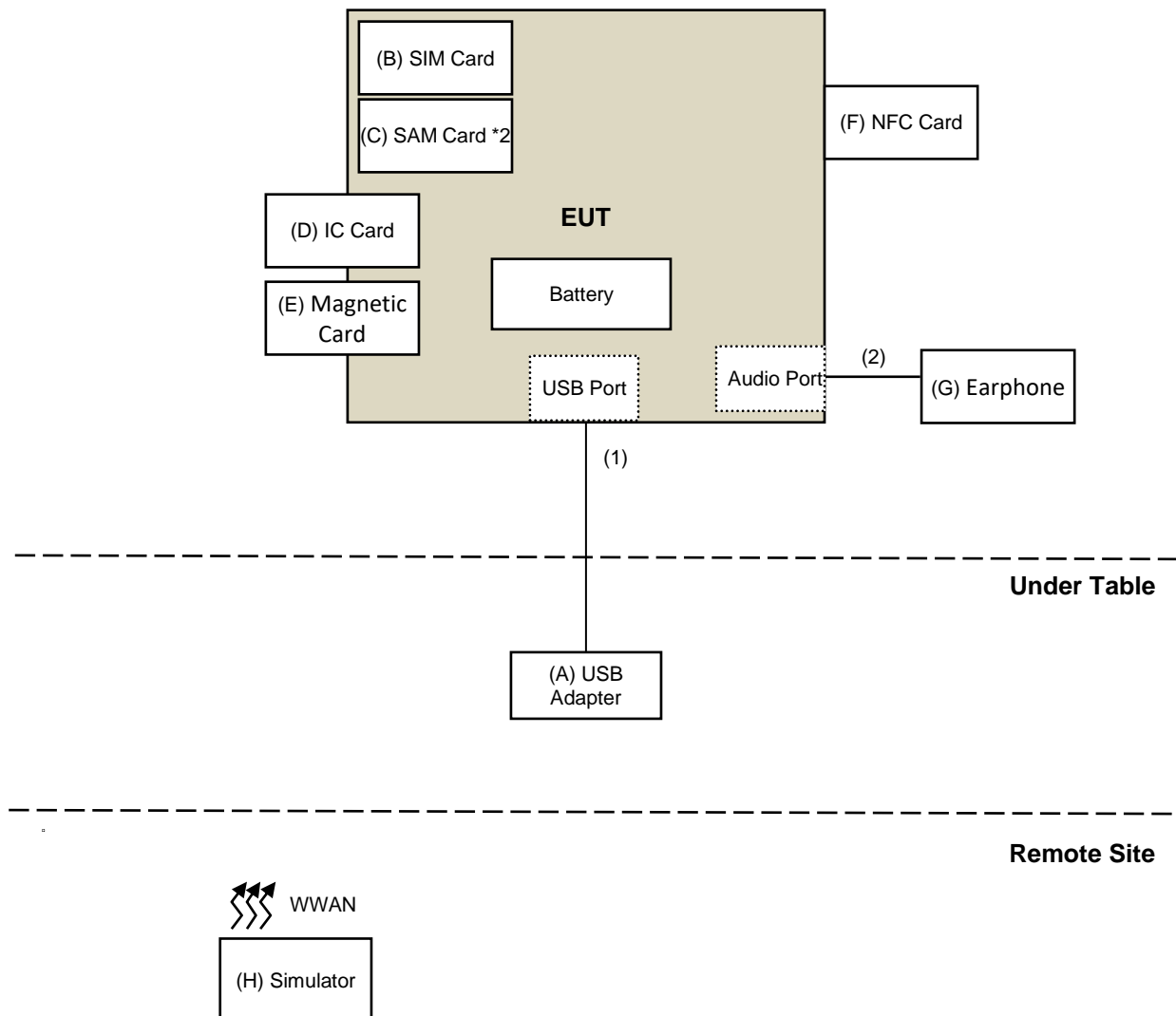

3.2.1 Description of Support Units

The EUT has been tested as an independent unit together with other necessary accessories or support units. The following support units or accessories were used to form a representative test configuration during the tests.

ID	Product	Brand	Model No.	Serial No.	FCC ID	Remarks
A.	USB Adapter	DEE VAN	DSA-18PFCA-05 050300	NA	NA	Supplied by client
B.	SIM Card	Keysight	NA	NA	NA	Provided by Lab
C.	SAM Card *2	XAC	NA	NA	NA	Supplied by client
D.	IC Card	XAC	NA	NA	NA	Supplied by client
E.	Magnetic Card	XAC	NA	NA	NA	Supplied by client
F.	NFC Card	XAC	NA	NA	NA	Supplied by client
G.	Earphone	Infinix	NA	NA	NA	Provided by Lab
H.	Simulator	Anritsu	MT8820C	6201127458	NA	Provided by Lab

Note:

1. All power cords of the above support units are non-shielded (1.8m).

ID	Descriptions	Qty.	Length (m)	Shielding (Yes/No)	Cores (Qty.)	Remarks
1.	USB Type C to USB Cable	1	1.2	Yes	0	Supplied by client
2.	earphone cable	1	1.5	No	0	Provided by Lab

3.3 Test Mode Applicability and Tested Channel Detail

WCDMA B2

Test Item	Available Channel	Tested Channel	Mode
EIRP	9262 to 9538	9262, 9400, 9538	WCDMA
Frequency Stability	9262 to 9538	9400	WCDMA
Occupied Bandwidth	9262 to 9538	9262, 9400, 9538	WCDMA
Band Edge	9262 to 9538	9262, 9538	WCDMA
Peak to Average Ratio	9262 to 9538	9262, 9400, 9538	WCDMA
Conducted Emission	9262 to 9538	9262, 9400, 9538	WCDMA
Radiated Emission Below 1GHz	9262 to 9538	9262, 9400, 9538	WCDMA
Radiated Emission Above 1GHz	9262 to 9538	9262, 9400, 9538	WCDMA

LTE Band 2

TEST ITEM	AVAILABLE CHANNEL	TESTED CHANNEL	CHANNEL BANDWIDTH	MODULATION	MODE
EIRP	18607 to 19193	18607, 18900 19193	1.4MHz	QPSK/16QAM	1RB / 0 RB offset
	18615 to 19185	18615, 18900, 19185	3MHz	QPSK/16QAM	1RB / 0 RB offset
	18625 to 19175	18625, 18900, 19175	5MHz	QPSK/16QAM	1RB / 0 RB offset
	18650 to 19150	18650, 18900, 19150	10MHz	QPSK/16QAM	1RB / 0 RB offset
	18675 to 19125	18675, 18900, 19125	15MHz	QPSK/16QAM	1RB / 0 RB offset
	18700 to 19100	18700, 18900, 19100	20MHz	QPSK/16QAM	1RB / 0 RB offset
Frequency Stability	18607 to 19193	18900	1.4MHz	QPSK	-
	18615 to 19185	18900	3MHz	QPSK	-
	18625 to 19175	18900	5MHz	QPSK	-
	18650 to 19150	18900	10MHz	QPSK	-
	18675 to 19125	18900	15MHz	QPSK	-
	18700 to 19100	18900	20MHz	QPSK	-
Occupied Bandwidth	18607 to 19193	18607, 18900 19193	1.4MHz	QPSK/16QAM	Full RB
	18615 to 19185	18615, 18900, 19185	3MHz	QPSK/16QAM	Full RB
	18625 to 19175	18625, 18900, 19175	5MHz	QPSK/16QAM	Full RB
	18650 to 19150	18650, 18900, 19150	10MHz	QPSK/16QAM	Full RB
	18675 to 19125	18675, 18900, 19125	15MHz	QPSK/16QAM	Full RB
	18700 to 19100	18700, 18900, 19100	20MHz	QPSK/16QAM	Full RB
Peak to Average Ratio	18607 to 19193	18607, 18900 19193	1.4MHz	QPSK/16QAM	Full RB
	18615 to 19185	18615, 18900, 19185	3MHz	QPSK/16QAM	Full RB
	18625 to 19175	18625, 18900, 19175	5MHz	QPSK/16QAM	Full RB
	18650 to 19150	18650, 18900, 19150	10MHz	QPSK/16QAM	Full RB
	18675 to 19125	18675, 18900, 19125	15MHz	QPSK/16QAM	Full RB
	18700 to 19100	18700, 18900, 19100	20MHz	QPSK/16QAM	Full RB

Band Edge	18607 to 19193	18607	1.4MHz	QPSK	1 RB / 0 RB Offset
		19193			1 RB / 5 RB Offset
		18607, 19193			6 RB / 0 RB Offset
	18615 to 19185	18615	3MHz	QPSK	1 RB / 0 RB Offset
		19185			1 RB / 14 RB Offset
		18615, 19185			15 RB / 0 RB Offset
	18625 to 19175	18625,	5MHz	QPSK	1 RB / 0 RB Offset
		19175			1 RB / 24 RB Offset
		18625, 19175			25 RB / 0 RB Offset
	18650 to 19150	18650	10MHz	QPSK	1 RB / 0 RB Offset
		19150			1 RB / 49 RB Offset
		18650, 19150			50 RB / 0 RB Offset
	18675 to 19125	18675,	15MHz	QPSK	1 RB / 0 RB Offset
		19125			1 RB / 74 RB Offset
		18675, 19125			75 RB / 0 RB Offset
	18700 to 19100	18700.	20MHz	QPSK	1 RB / 0 RB Offset
		19100			1 RB / 99 RB Offset
		18700. 19100			100 RB / 0 RB Offset
Conducted Emission	18607 to 19193	18607, 18900 19193	1.4MHz	QPSK	1 RB / 0 RB Offset
	18615 to 19185	18615, 18900, 19185	3MHz	QPSK	1 RB / 0 RB Offset
	18625 to 19175	18625, 18900, 19175	5MHz	QPSK	1 RB / 0 RB Offset
	18650 to 19150	18650, 18900, 19150	10MHz	QPSK	1 RB / 0 RB Offset
	18675 to 19125	18675, 18900, 19125	15MHz	QPSK	1 RB / 0 RB Offset
	18700 to 19100	18700, 18900, 19100	20MHz	QPSK	1 RB / 0 RB Offset
Radiated Emission	18607 to 19193	18607, 18900 19193	1.4MHz	QPSK	1 RB / 0 RB Offset
	18615 to 19185	18615, 18900, 19185	3MHz	QPSK	1 RB / 0 RB Offset
	18625 to 19175	18625, 18900, 19175	5MHz	QPSK	1 RB / 0 RB Offset
	18650 to 19150	18650, 18900, 19150	10MHz	QPSK	1 RB / 0 RB Offset
	18675 to 19125	18675, 18900, 19125	15MHz	QPSK	1 RB / 0 RB Offset
	18700 to 19100	18700, 18900, 19100	20MHz	QPSK	1 RB / 0 RB Offset

NOTE:

All supported modulation types were evaluated. The Worst case of QPSK was selected. Therefore, the Band Edge, Frequency Stability, Condcudeted Emission and Radiated Emission were presented under QPSK mode only.

Test Condition:

Test Item	Environmental Conditions	Input Power (System)	Tested By
EIRP	23deg. C, 62%RH	120Vac, 60Hz	Allen Chuang
Frequency Stability	23deg. C, 62%RH	120Vac, 60Hz	Allen Chuang
Occupied Bandwidth	23deg. C, 62%RH	120Vac, 60Hz	Allen Chuang
Band Edge	23deg. C, 62%RH	120Vac, 60Hz	Allen Chuang
Peak to Average Ratio	23deg. C, 62%RH	120Vac, 60Hz	Allen Chuang
Condcudeted Emission	23deg. C, 62%RH	120Vac, 60Hz	Allen Chuang
Radiated Emission Below 1GHz	25deg. C, 75%RH	120Vac, 60Hz	Nelson Teng
Radiated Emission Above 1GHz	25deg. C, 75%RH	120Vac, 60Hz	Nelson Teng

3.4 EUT Operating Conditions

The communication simulator station system controlled a EUT to export maximum output power under transmission mode and specific channel frequency

3.5 General Description of Applied Standards and references

The EUT is a RF Product. According to the specifications of the manufacturer, it must comply with the requirements of the following standards and references:

Test standard:

FCC 47 CFR Part 2

FCC 47 CFR Part 24 Subpart E

ANSI/TIA/EIA-603-E 2016

ANSI 63.26-2015

All test items have been performed and recorded as per the above standards.

References Test Guidance :

KDB 971168 D01 Power Meas License Digital Systems v03r01

All test items have been performed as a reference to the above KDB test guidance.

4 Test Types and Results

4.1 Output Power Measurement

4.1.1 Limits of Output Power Measurement

Mobile / Portable station are limited to 2 watts e.i.r.p.

4.1.2 Test Procedures

Conducted Power Measurement:

The EUT was set up for the maximum power with WCDMA/LTE link data modulation and link up with simulator. Set the EUT to transmit under low, middle and high channel and difference RB size/ RB offset for difference bandwidth record the power level shown on power meter.

EIRP Measurement:

- a. $EIRP = \text{Conducted Output power level} + \text{Antenna gain.}$

4.1.3 Test Setup

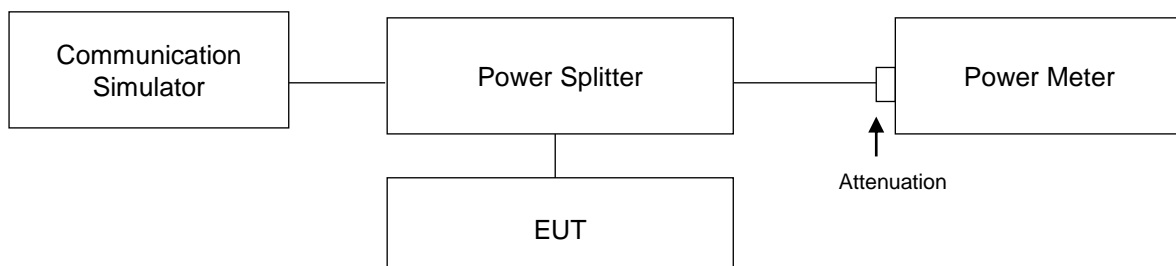

For the actual test configuration, please refer to the attached file (Test Setup Photo).

4.1.4 Test Results

CONDUCTED OUTPUT POWER (dBm)
WCDMA B2

Band	WCDMA B2		
	9262	9400	9538
Channel	1852.4	1880.0	1907.6
Frequency (MHz)	22.01	22.19	22.05
RMC	21.72	21.90	21.76
HSDPA Subtest-1	21.67	21.85	21.71
HSDPA Subtest-2	21.23	21.41	21.27
HSDPA Subtest-3	21.21	21.39	21.25
HSDPA Subtest-4	21.17	21.35	21.21
HSUPA Subtest-1	19.67	19.85	19.71
HSUPA Subtest-2	20.56	20.74	20.60
HSUPA Subtest-3	19.28	19.46	19.32
HSUPA Subtest-4	21.63	21.81	21.67
HSUPA Subtest-5			

LTE Band 2

Band / BW	RB Size	RB Offset	QPSK			3GPP MPR (dB)	16QAM			3GPP MPR (dB)	
			Low CH	Mid CH	High CH		Low CH	Mid CH	High CH		
			18607	18900	19193		18607	18900	19193		
			1850.7	1880	1909.3		1850.7	1880	1909.3		
			MHz	MHz	MHz						
2 / 1.4M	1	0	22.10	22.21	22.22	0	21.19	21.30	21.31	1	
	1	2	22.01	22.12	22.13	0	21.12	21.23	21.24	1	
	1	5	21.79	21.90	21.91	0	21.07	21.18	21.19	1	
	3	0	22.02	22.13	22.14	0	21.18	21.29	21.30	1	
	3	1	21.90	22.01	22.02	0	21.16	21.27	21.28	1	
	3	3	21.87	21.98	21.99	0	21.13	21.24	21.25	1	
	6	0	20.89	21.00	21.01	1	19.95	20.06	20.07	2	

Band / BW	RB Size	RB Offset	QPSK			3GPP MPR (dB)	16QAM			3GPP MPR (dB)	
			Low CH	Mid CH	High CH		Low CH	Mid CH	High CH		
			18615	18900	19185		18615	18900	19185		
			1851.5	1880	1908.5		1851.5	1880	1908.5		
			MHz	MHz	MHz						
2 / 3M	1	0	22.15	22.26	22.27	0	21.24	21.35	21.36	1	
	1	7	22.06	22.17	22.18	0	21.17	21.28	21.29	1	
	1	14	21.84	21.95	21.96	0	21.12	21.23	21.24	1	
	8	0	21.02	21.13	21.14	1	20.09	20.20	20.21	2	
	8	3	20.90	21.01	21.02	1	20.07	20.18	20.19	2	
	8	7	20.87	20.98	20.99	1	20.04	20.15	20.16	2	
	15	0	20.94	21.05	21.06	1	20.00	20.11	20.12	2	

Band / BW	RB Size	RB Offset	QPSK			3GPP MPR (dB)	16QAM			3GPP MPR (dB)	
			Low CH	Mid CH	High CH		Low CH	Mid CH	High CH		
			18625	18900	19175		18625	18900	19175		
			1852.5	1880	1907.5		1852.5	1880	1907.5		
			MHz	MHz	MHz						
2 / 5M	1	0	22.19	22.30	22.31	0	21.28	21.39	21.40	1	
	1	12	22.10	22.21	22.22	0	21.21	21.32	21.33	1	
	1	24	21.88	21.99	22.00	0	21.16	21.27	21.28	1	
	12	0	21.06	21.17	21.18	1	20.13	20.24	20.25	2	
	12	6	20.94	21.05	21.06	1	20.11	20.22	20.23	2	
	12	13	20.91	21.02	21.03	1	20.08	20.19	20.20	2	
	25	0	20.98	21.09	21.10	1	20.04	20.15	20.16	2	

Band / BW	RB Size	RB Offset	QPSK			3GPP MPR (dB)	16QAM			3GPP MPR (dB)
			Low CH	Mid CH	High CH		Low CH	Mid CH	High CH	
			18650	18900	19150		18650	18900	19150	
			1855	1880	1905		1855	1880	1905	
			MHz	MHz	MHz		MHz	MHz	MHz	
2 / 10M	1	0	22.23	22.34	22.35	0	21.32	21.43	21.44	1
	1	24	22.14	22.25	22.26	0	21.25	21.36	21.37	1
	1	49	21.92	22.03	22.04	0	21.20	21.31	21.32	1
	25	0	21.10	21.21	21.22	1	20.17	20.28	20.29	2
	25	12	20.98	21.09	21.10	1	20.15	20.26	20.27	2
	25	25	20.95	21.06	21.07	1	20.12	20.23	20.24	2
	50	0	21.02	21.13	21.14	1	20.08	20.19	20.20	2

Band / BW	RB Size	RB Offset	QPSK			3GPP MPR (dB)	16QAM			3GPP MPR (dB)
			Low CH	Mid CH	High CH		Low CH	Mid CH	High CH	
			18675	18900	19125		18675	18900	19125	
			1857.5	1880	1902.5		1857.5	1880	1902.5	
			MHz	MHz	MHz		MHz	MHz	MHz	
2 / 15M	1	0	22.28	22.39	22.40	0	21.37	21.48	21.49	1
	1	37	22.19	22.30	22.31	0	21.30	21.41	21.42	1
	1	74	21.97	22.08	22.09	0	21.25	21.36	21.37	1
	36	0	21.15	21.26	21.27	1	20.22	20.33	20.34	2
	36	19	21.03	21.14	21.15	1	20.20	20.31	20.32	2
	36	39	21.00	21.11	21.12	1	20.17	20.28	20.29	2
	75	0	21.07	21.18	21.19	1	20.13	20.24	20.25	2

Band / BW	RB Size	RB Offset	QPSK			3GPP MPR (dB)	16QAM			3GPP MPR (dB)
			Low CH	Mid CH	High CH		Low CH	Mid CH	High CH	
			18700	18900	19100		18700	18900	19100	
			1860	1880	1900		1860	1880	1900	
			MHz	MHz	MHz		MHz	MHz	MHz	
2 / 20M	1	0	22.31	22.42	22.43	0	21.40	21.51	21.52	1
	1	50	22.22	22.33	22.34	0	21.33	21.44	21.45	1
	1	99	22.00	22.11	22.12	0	21.28	21.39	21.40	1
	50	0	21.28	21.39	21.41	1	20.25	20.36	20.37	2
	50	25	21.06	21.17	21.18	1	20.23	20.34	20.35	2
	50	50	21.03	21.14	21.15	1	20.20	20.31	20.32	2
	100	0	21.10	21.21	21.22	1	20.16	20.27	20.28	2

EIRP POWER
WCDMA B2

Band	WCDMA B2		
Channel	9262	9400	9538
Frequency (MHz)	1852.4	1880	1907.6
RMC	22.01	22.19	22.05
Gain (dBi)	2.65	2.65	2.65
Max EIRP Power (dBm)	24.66	24.84	24.70

LTE Band 2

Band / BW	RB Size	RB Offset	QPSK			3GPP MPR (dB)	16QAM			3GPP MPR (dB)
			Low CH	Mid CH	High CH		Low CH	Mid CH	High CH	
			18607	18900	19193		18607	18900	19193	
			1850.7	1880	1909.3		1850.7	1880	1909.3	
			MHz	MHz	MHz		MHz	MHz	MHz	
2 / 1.4M	1	0	22.10	22.21	22.22	0	21.19	21.30	21.31	1
Gain (dBi)		2.65	2.65	2.65	2.65		2.65	2.65		
Max EIRP Power (dBm)		24.75	24.86	24.87	23.84		23.95	23.96		

Band / BW	RB Size	RB Offset	QPSK			3GPP MPR (dB)	16QAM			3GPP MPR (dB)
			Low CH	Mid CH	High CH		Low CH	Mid CH	High CH	
			18615	18900	19185		18615	18900	19185	
			1851.5	1880	1908.5		1851.5	1880	1908.5	
			MHz	MHz	MHz		MHz	MHz	MHz	
2 / 3M	1	0	22.15	22.26	21.06	0	21.24	21.35	21.36	1
Gain (dBi)		2.65	2.65	2.65	2.65		2.65	2.65		
Max EIRP Power (dBm)		24.80	24.91	23.71	23.89		24.00	24.01		

Band / BW	RB Size	RB Offset	QPSK			3GPP MPR (dB)	16QAM			3GPP MPR (dB)
			Low CH	Mid CH	High CH		Low CH	Mid CH	High CH	
			18625	18900	19175		18625	18900	19175	
			1852.5	1880	1907.5		1852.5	1880	1907.5	
			MHz	MHz	MHz		MHz	MHz	MHz	
2 / 5M	1	0	22.19	22.30	22.31	0	21.28	21.39	21.40	1
Gain (dBi)		2.65	2.65	2.65	2.65		2.65	2.65		
Max EIRP Power (dBm)		24.84	24.95	24.96	23.93		24.04	24.05		

Band / BW	RB Size	RB Offset	QPSK			3GPP MPR (dB)	16QAM			3GPP MPR (dB)
			Low CH	Mid CH	High CH		Low CH	Mid CH	High CH	
			18650	18900	19150		20000	20175	20350	
			1855	1880	1905		1715	1732.5	1750	
			MHz	MHz	MHz		MHz	MHz	MHz	
2 / 10M	1	0	22.23	22.34	22.35	0	21.32	21.43	21.44	1
Gain (dBi)		2.65	2.65	2.65	2.65		2.65	2.65		
Max EIRP Power (dBm)		24.88	24.99	25.00	23.97		24.08	24.09		

Band / BW	RB Size	RB Offset	QPSK			3GPP MPR (dB)	16QAM			3GPP MPR (dB)
			Low CH	Mid CH	High CH		Low CH	Mid CH	High CH	
			18675	18900	19125		18675	18900	19125	
			1857.5	1880	1902.5		1857.5	1880	1902.5	
			MHz	MHz	MHz		MHz	MHz	MHz	
2 / 15M	1	0	22.28	22.39	22.40	0	21.37	21.48	21.49	1
Gain (dBi)			2.65	2.65	2.65		2.65	2.65	2.65	
Max EIRP Power (dBm)			24.93	25.04	25.05		24.02	24.13	24.14	

Band / BW	RB Size	RB Offset	QPSK			3GPP MPR (dB)	16QAM			3GPP MPR (dB)
			Low CH	Mid CH	High CH		Low CH	Mid CH	High CH	
			18700	18900	19100		18700	18900	19100	
			1860	1880	1900		1860	1880	1900	
			MHz	MHz	MHz		MHz	MHz	MHz	
2 / 20M	1	0	22.31	22.42	22.43	0	21.40	21.51	21.52	1
Gain (dBi)			2.65	2.65	2.65		2.65	2.65	2.65	
Max EIRP Power (dBm)			24.96	25.07	25.08		24.05	24.16	24.17	

4.2 Modulation Characteristics Measurement

4.2.1 Limits of Modulation Characteristics

N/A

4.2.2 Test Procedure

Connect the EUT to Communication Simulator via the antenna connector. The frequency band is set as EUT supported Modulation and Channels, the EUT output is matched with 50 ohm load, the waveform quality and constellation of the EUT was tested.

4.2.3 Test Setup



4.2.4 Test Results

WCDMA B2

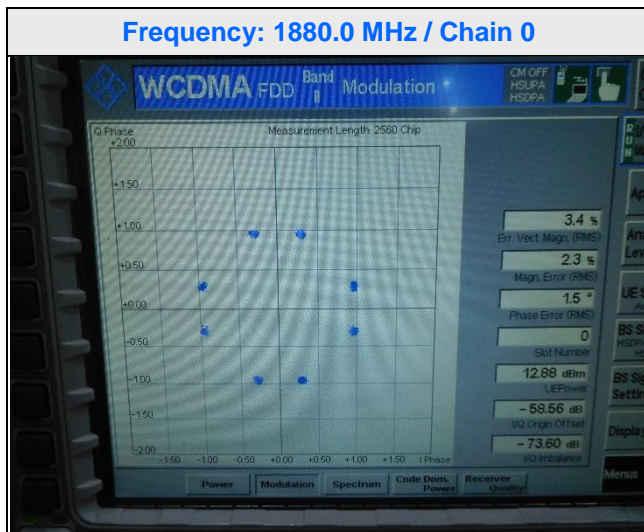

LTE Band 2

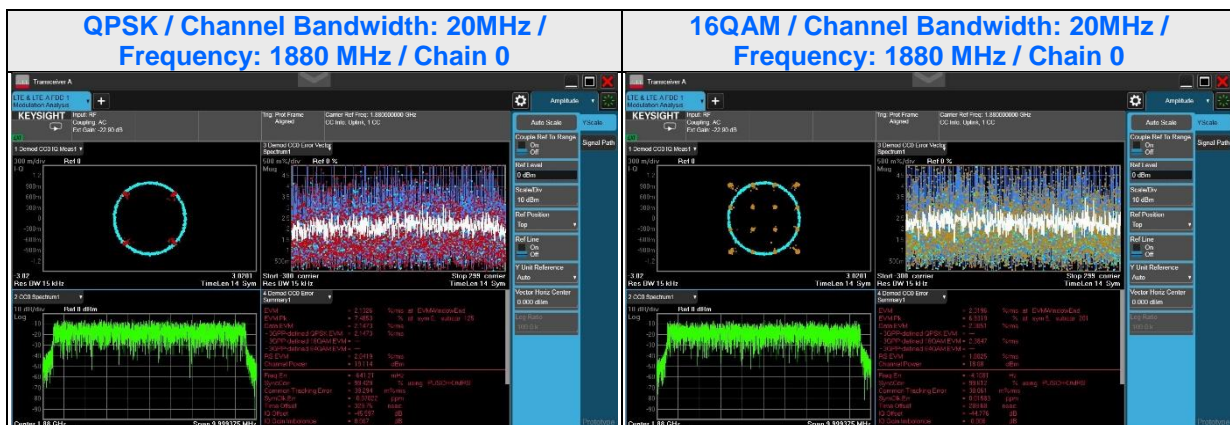

4.3 Frequency Stability Measurement

4.3.1 Limits of Frequency Stability Measurement

The frequency stability shall be sufficient to ensure that the fundamental emission stays within the authorized frequency block.

4.3.2 Test Procedure

- a. Device is placed at the oven room. The oven room could control the temperatures and humidity. Power warm up is at least 15 min and power applied should perform before recording frequency error.
- b. EUT is connected the external power supply to control the AC input power. The test voltage range is from minimum to maximum working voltage. Each step shall be record the frequency error rate.
- c. The temperature range step is 10 degrees in this test items. All temperature levels shall be hold the ± 0.5 °C during the measurement testing. The each temperature step shall be at least 0.5 hours, consider the EUT could be test under the stability condition.

NOTE: The frequency error was recorded frequency error from the communication simulator.

4.3.3 Test Setup

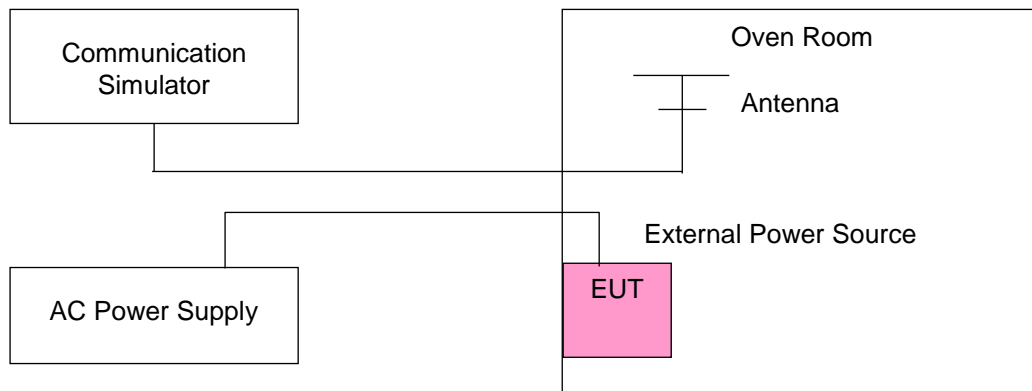

4.3.4 Test Results

WCDMA B2

Frequency Error vs. Voltage

Voltage (Volts)	Frequency Error (MHz)		Limit (MHz)	
	WCDMA B2		Low Edge	High Edge
	Low	High		
102	1850.319993	1909.690000	1850	1910
138	1850.320000	1909.689990	1850	1910

Frequency Error vs. Temperature.

TEMP. (°C)	Frequency Error (MHz)		Limit (MHz)	
	WCDMA B2		Low Edge	High Edge
	Low	High		
50	1850.319996	1909.689995	1850	1910
40	1850.320002	1909.690009	1850	1910
30	1850.320000	1909.690002	1850	1910
20	1850.320007	1909.690006	1850	1910
10	1850.319994	1909.689995	1850	1910
0	1850.320000	1909.689999	1850	1910
-10	1850.319995	1909.689993	1850	1910
-20	1850.319992	1909.689998	1850	1910
-30	1850.319999	1909.690008	1850	1910

LTE Band 2

Frequency Error vs. Voltage

Voltage (Volts)	Frequency Error (MHz)												Limit (MHz)	
	1.4MHz		3MHz		5MHz		10MHz		15MHz		20MHz		Low Edge	High Edge
	Low	High	Low	High	Low	High	Low	High	Low	High	Low	High		
102	1850.159999	1909.840002	1850.150001	1909.839996	1850.260007	1909.750008	1850.539999	1909.479992	1850.840000	1909.219991	1851.080009	1908.919997	1850	1910
138	1850.160006	1909.840000	1850.149997	1909.839999	1850.260006	1909.750005	1850.539995	1909.479990	1850.839996	1909.219995	1851.080003	1908.920002	1850	1910

Frequency Error vs. Temperature

Temp. (°C)	Frequency Error (MHz)												Limit (MHz)	
	1.4MHz		3MHz		5MHz		10MHz		15MHz		20MHz		Low Edge	High Edge
	Low	High	Low	High	Low	High	Low	High	Low	High	Low	High		
50	1850.160007	1909.839997	1850.150000	1909.839996	1850.259997	1909.750002	1850.539991	1909.479995	1850.839993	1909.219992	1851.080009	1908.919999	1850	1910
40	1850.160004	1909.839991	1850.150004	1909.839990	1850.259999	1909.750003	1850.540004	1909.479990	1850.840008	1909.219990	1851.080008	1908.919992	1850	1910
30	1850.160002	1909.840004	1850.149993	1909.839997	1850.260009	1909.750009	1850.540003	1909.480002	1850.839996	1909.219990	1851.079990	1908.920001	1850	1910
20	1850.160002	1909.839998	1850.149994	1909.840007	1850.260003	1909.749998	1850.539993	1909.480003	1850.839991	1909.220008	1851.080000	1908.919995	1850	1910
10	1850.160006	1909.839990	1850.149992	1909.839991	1850.260007	1909.749995	1850.540004	1909.480002	1850.839993	1909.220009	1851.079990	1908.919999	1850	1910
0	1850.160002	1909.840006	1850.150003	1909.840007	1850.259995	1909.749996	1850.539996	1909.480001	1850.840003	1909.220003	1851.080002	1908.920007	1850	1910
-10	1850.159997	1909.840005	1850.149999	1909.839990	1850.259998	1909.749996	1850.540001	1909.479997	1850.840003	1909.219995	1851.080003	1908.919993	1850	1910
-20	1850.160000	1909.839993	1850.149991	1909.840008	1850.259997	1909.749995	1850.539997	1909.479993	1850.840004	1909.220004	1851.079996	1908.919990	1850	1910
-30	1850.159990	1909.840003	1850.150005	1909.840004	1850.260007	1909.750005	1850.539991	1909.479994	1850.840006	1909.219997	1851.080002	1908.920007	1850	1910

4.4 Occupied Bandwidth Measurement

4.4.1 Test Procedure

All measurements were done at low, middle and high operational frequency range. The communication simulator station system controlled a EUT to export maximum output power under transmission mode and specific channel frequency. The bandwidth of the fundamental frequency was measured by spectrum analyzer with $RBW \geq 1\% \times OBW$ and $VBW \geq 3 \times VBW$.

Occupied Bandwidth Measurement:

Use OBW measurement function of Spectrum analyzer to measure 99 % occupied bandwidth.

26 dB Bandwidth Measurement:

The emission bandwidth is defined as the width of the signal between two points, one below the carrier center frequency and one above the carrier center frequency, outside of which all emission are attenuated at least 26dB below the transmitter power.

4.4.2 Test Setup

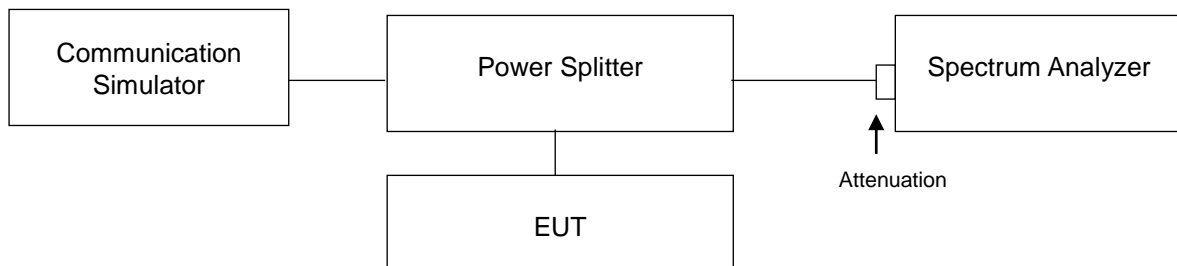

4.4.3 Test Result (-26dB Bandwidth)

Channel	Freq. (MHz)	-26dB Bandwidth (MHz)
		WCDMA B2
9262	1852.4	4.69
9400	1880.0	4.70
9538	1907.6	4.69

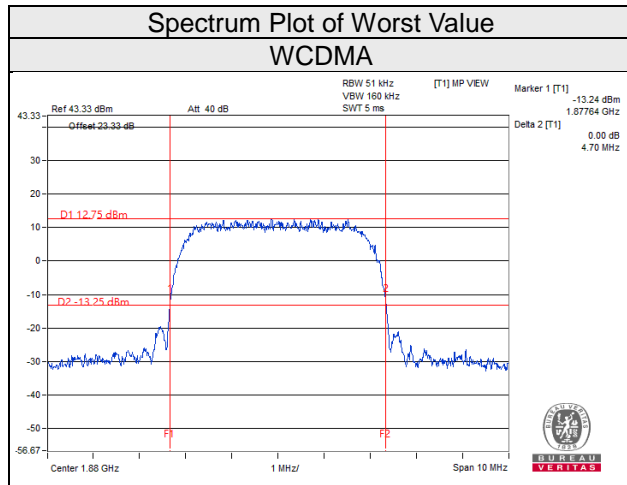

LTE Band 2							
Channel Bandwidth 1.4MHz				Channel Bandwidth 3MHz			
Channel	Frequency (MHz)	-26dB Bandwidth (MHz)		Channel	Frequency (MHz)	-26dB Bandwidth (MHz)	
		QPSK	16QAM			QPSK	16QAM
18607	1850.7	1.26	1.27	18615	1851.5	2.95	2.93
18900	1880	1.26	1.25	18900	1880	2.93	2.89
19193	1909.3	1.24	1.25	19185	1908.5	2.95	2.91
Channel Bandwidth 5MHz				Channel Bandwidth 10MHz			
Channel	Frequency (MHz)	-26dB Bandwidth (MHz)		Channel	Frequency (MHz)	-26dB Bandwidth (MHz)	
		QPSK	16QAM			QPSK	16QAM
18625	1852.5	4.93	4.92	18650	1855	9.67	9.73
18900	1880	4.91	4.96	18900	1880	9.71	9.67
19175	1907.5	4.86	4.88	19150	1905	9.75	9.68
Channel Bandwidth 15MHz				Channel Bandwidth 20MHz			
Channel	Frequency (MHz)	-26dB Bandwidth (MHz)		Channel	Frequency (MHz)	-26dB Bandwidth (MHz)	
		QPSK	16QAM			QPSK	16QAM
18675	1857.5	14.48	14.41	18700	1860	19.02	18.97
18900	1880	14.53	14.48	18900	1880	19.16	19.23
19125	1902.5	14.55	14.49	19100	1900	19.13	19.12

Spectrum Plot of Worst Value

1.4MHz / 16QAM

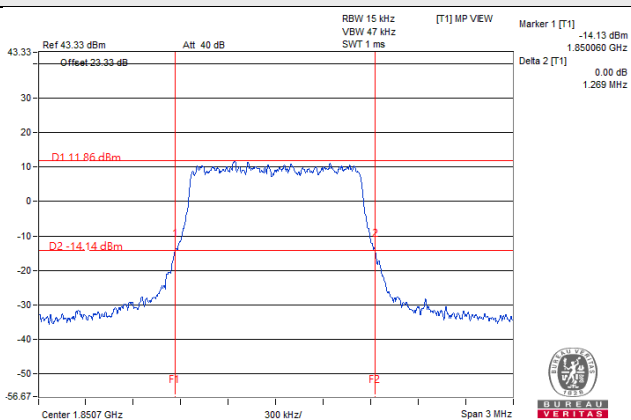

3MHz / QPSK

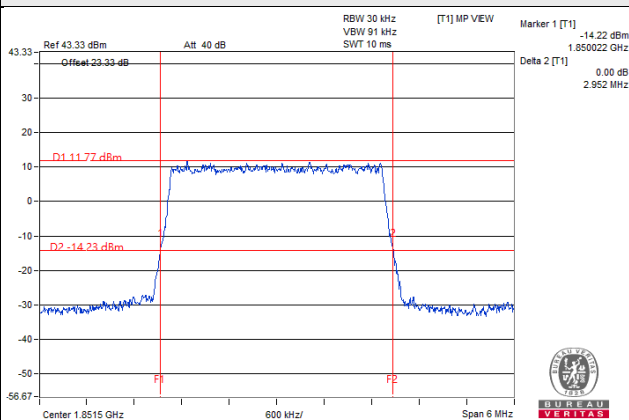

5MHz / 16QAM

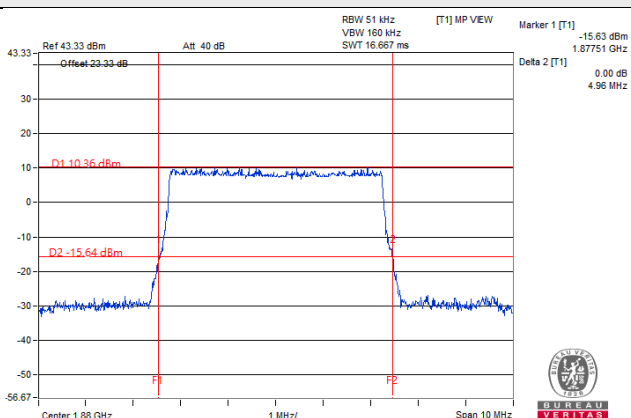

10MHz / QPSK

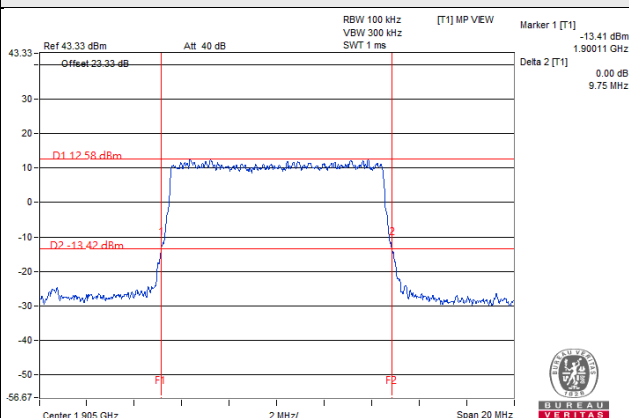

15MHz / QPSK

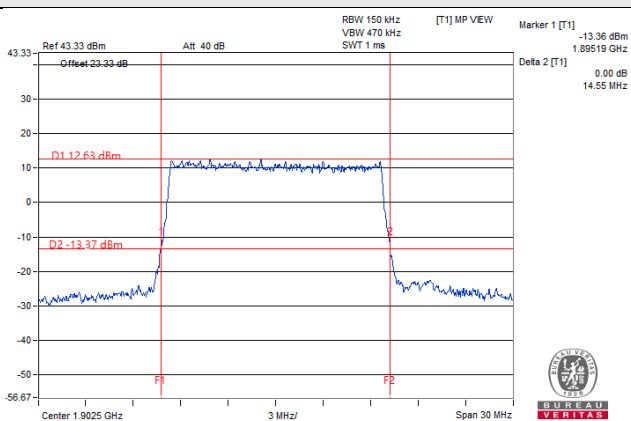

20MHz / 16QAM

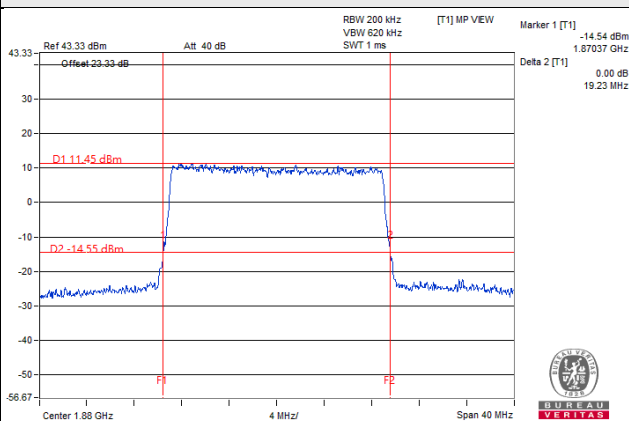

4.4.4 Test Result (Occupied Bandwidth)

Channel	Freq. (MHz)	99% Occupied Bandwidth (MHz)
		WCDMA B2
9262	1852.4	4.16
9400	1880.0	4.16
9538	1907.6	4.17

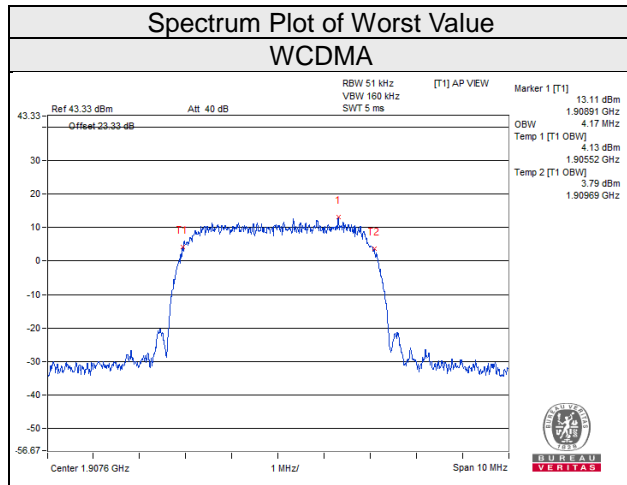

LTE Band 2							
Channel Bandwidth 1.4MHz				Channel Bandwidth 3MHz			
Channel	Frequency (MHz)	99% Occupied Bandwidth (MHz)		Channel	Frequency (MHz)	99% Occupied Bandwidth (MHz)	
		QPSK	16QAM			QPSK	16QAM
18607	1850.7	1.08	1.08	18615	1851.5	2.69	2.68
18900	1880	1.08	1.08	18900	1880	2.69	2.68
19193	1909.3	1.08	1.08	19185	1908.5	2.68	2.68
Channel Bandwidth 5MHz				Channel Bandwidth 10MHz			
Channel	Frequency (MHz)	99% Occupied Bandwidth (MHz)		Channel	Frequency (MHz)	99% Occupied Bandwidth (MHz)	
		QPSK	16QAM			QPSK	16QAM
18625	1852.5	4.48	4.48	18650	1855	8.94	8.94
18900	1880	4.49	4.47	18900	1880	8.96	8.94
19175	1907.5	4.48	4.46	19150	1905	8.96	8.96
Channel Bandwidth 15MHz				Channel Bandwidth 20MHz			
Channel	Frequency (MHz)	99% Occupied Bandwidth (MHz)		Channel	Frequency (MHz)	99% Occupied Bandwidth (MHz)	
		QPSK	16QAM			QPSK	16QAM
18675	1857.5	13.38	13.41	18700	1860	17.88	17.76
18900	1880	13.44	13.41	18900	1880	17.96	17.92
19125	1902.5	13.44	13.41	19100	1900	17.84	17.84

Spectrum Plot of Worst Value

1.4MHz / QPSK

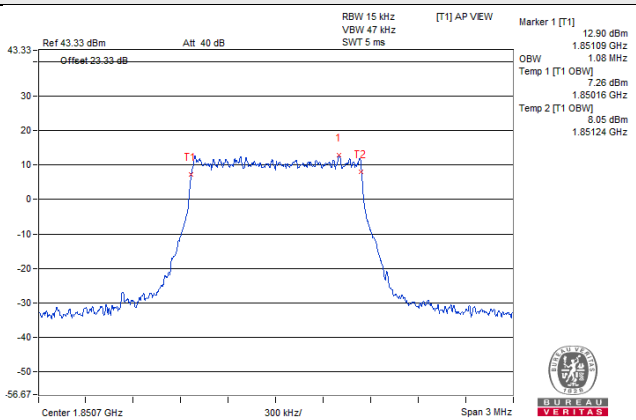

3MHz / QPSK

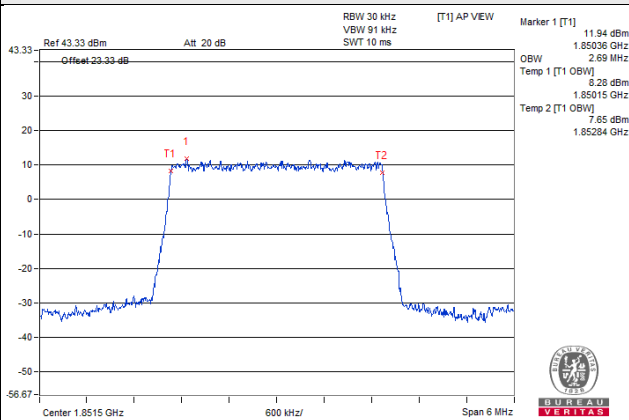

5MHz / QPSK

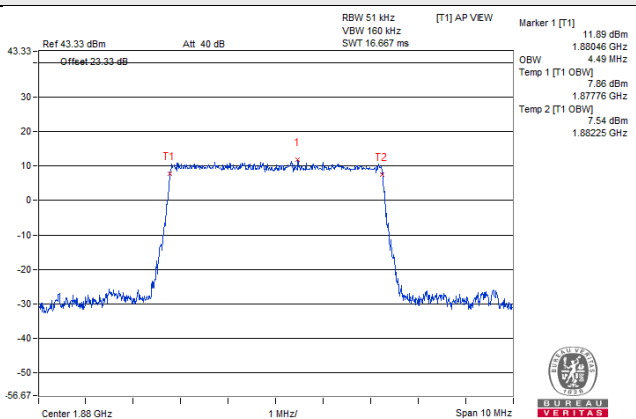

10MHz / QPSK

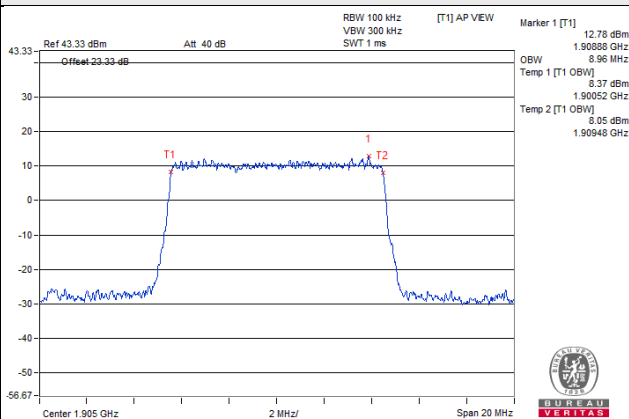

15MHz / QPSK

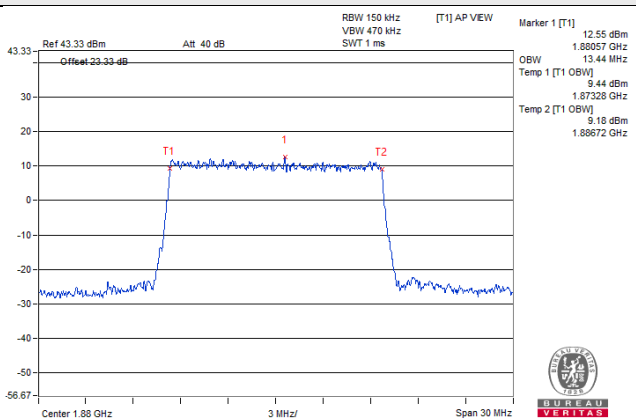

20MHz / QPSK

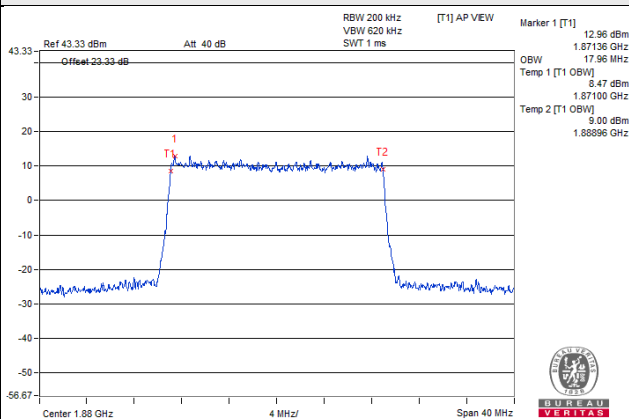

4.5 Band Edge Measurement

4.5.1 Limits of Band Edge Measurement

Power of any emission outside of the authorized operating frequency ranges must be attenuated below the transmitting power (P) by a factor of at least $43 + 10 \log(P)$ dB. In the 1 MHz bands immediately outside and adjacent to the frequency block a resolution bandwidth of at least one percent of the emission bandwidth of the fundamental emission of the transmitter may be employed.

4.5.2 Test Setup

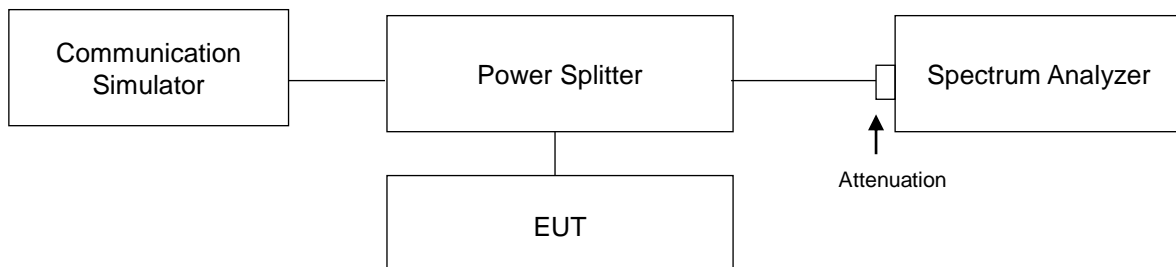

4.5.3 Test Procedures

- a. All measurements were done at low and high operational frequency range.
- b. The center frequency of spectrum is the band edge frequency and RB of the spectrum is $>1\%$ emission bandwidth and VB of the spectrum is $\geq 3*RB$.
- c. Record the max trace plot into the test report.

4.5.4 Test Results

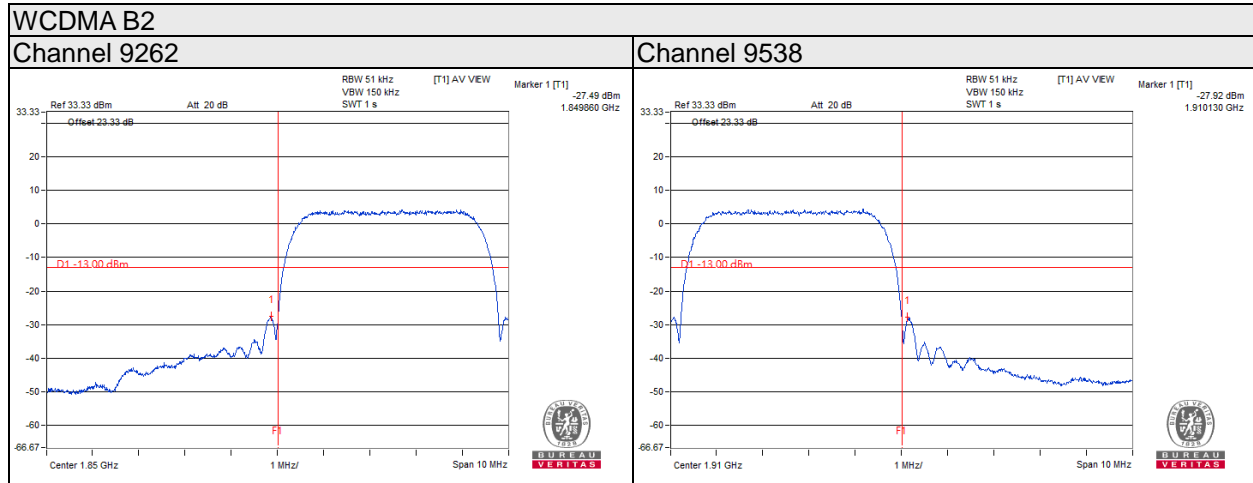

LTE Band 2 Channel Bandwidth: 1.4MHz

Channel 18607

1 RB

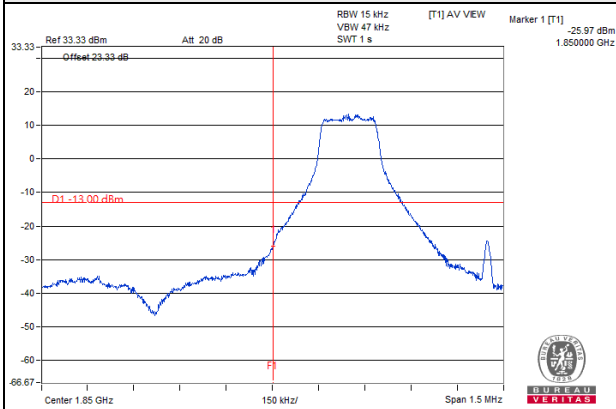

Channel 19193

1 RB

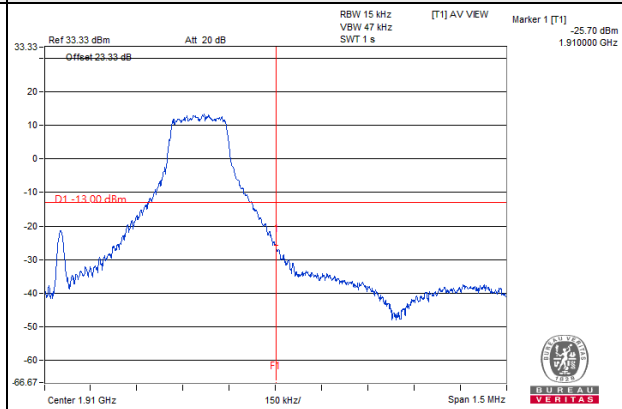

6 RB

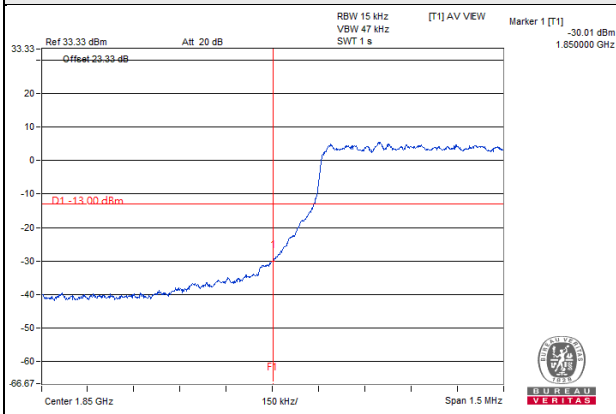

6 RB

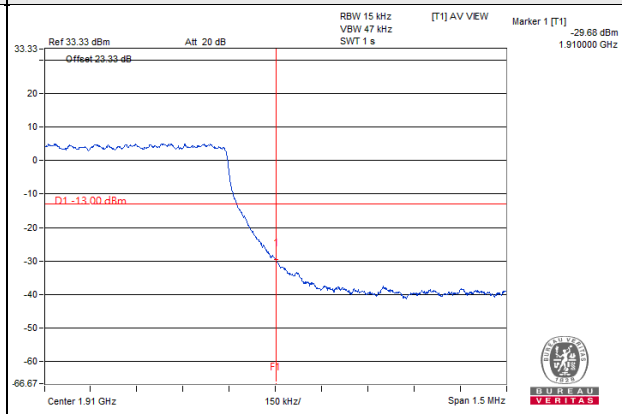

LTE Band 2 Channel Bandwidth: 3MHz

Channel 18615

1 RB

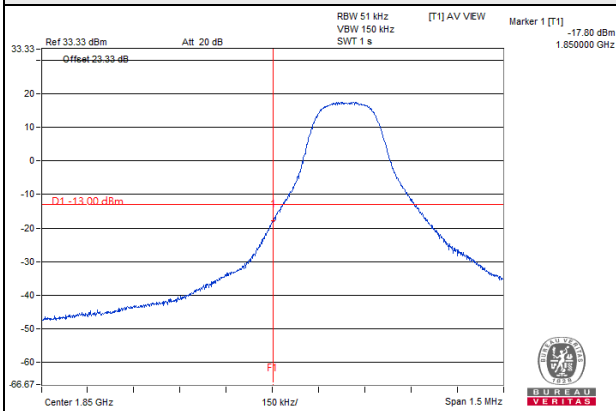

Channel 19185

1 RB

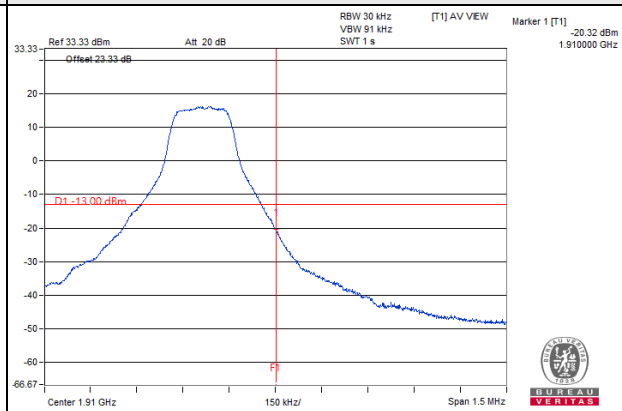

15 RB

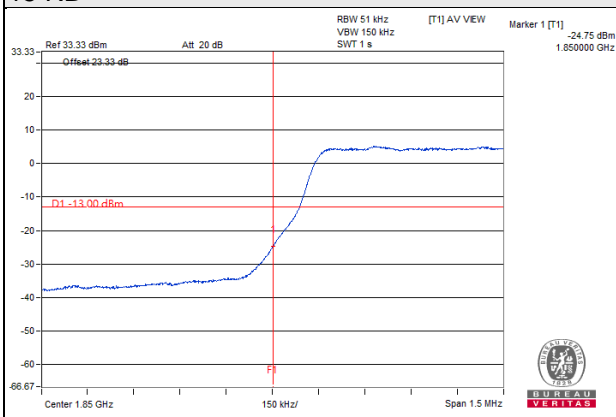

15 RB

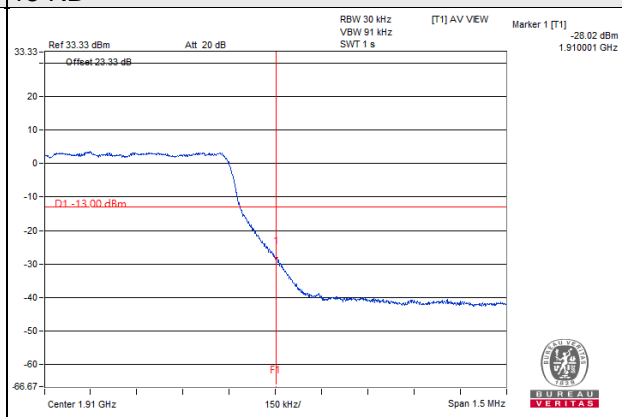

LTE Band 2 Channel Bandwidth: 5MHz

Channel 18625

1 RB

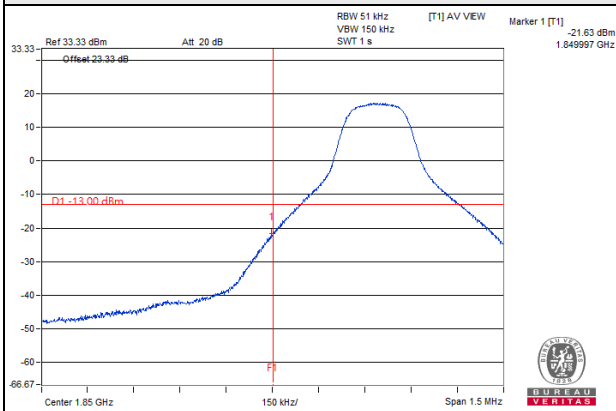

Channel 19175

1 RB

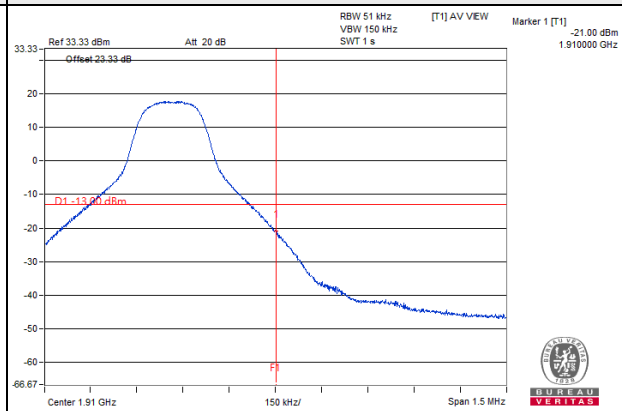

25 RB

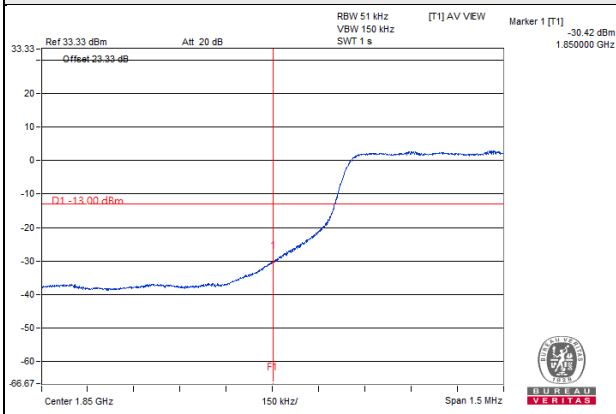

25 RB

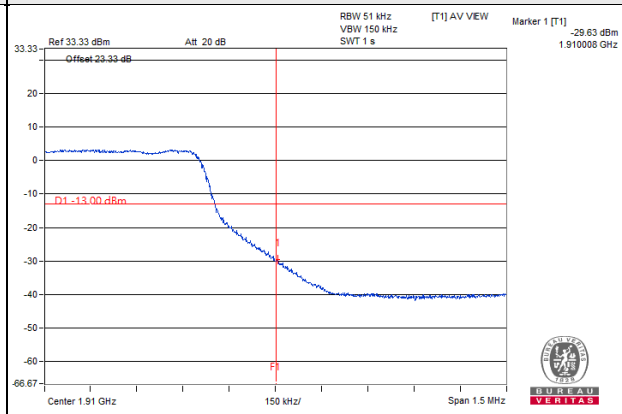

LTE Band 2 Channel Bandwidth: 10MHz

Channel 18650

1 RB

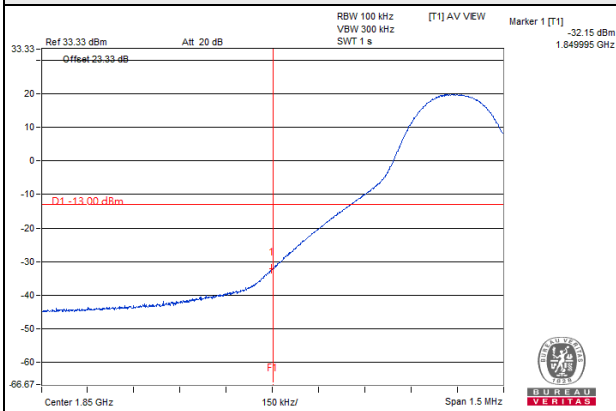

Channel 19150

1 RB

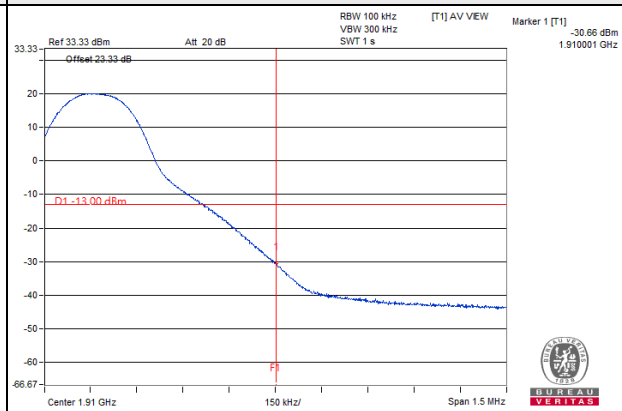

50 RB

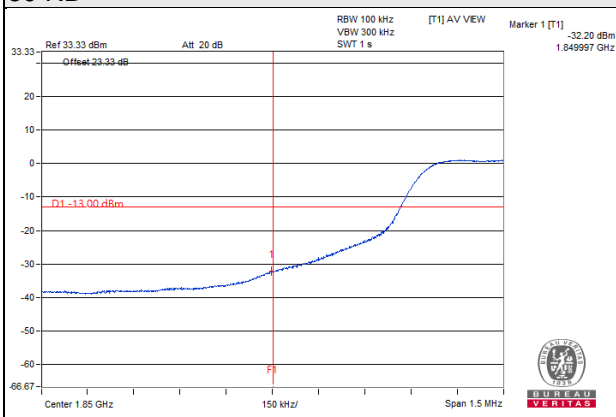

50 RB

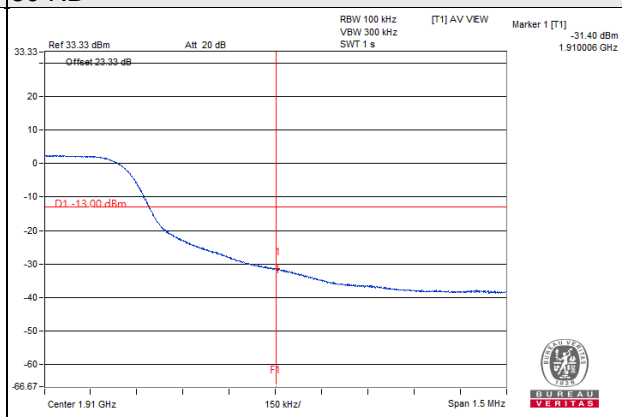

LTE Band 2 Channel Bandwidth: 15MHz

Channel 18675

1 RB

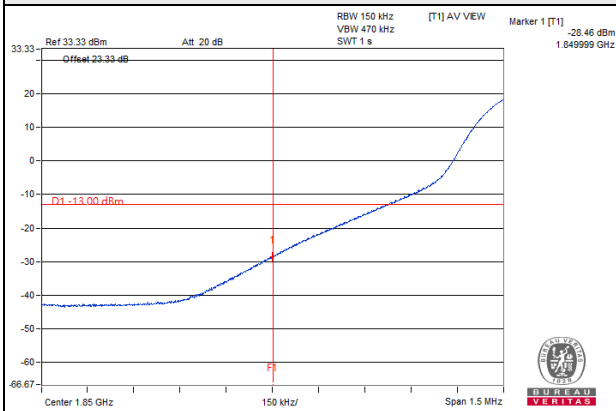

Channel 19125

1 RB

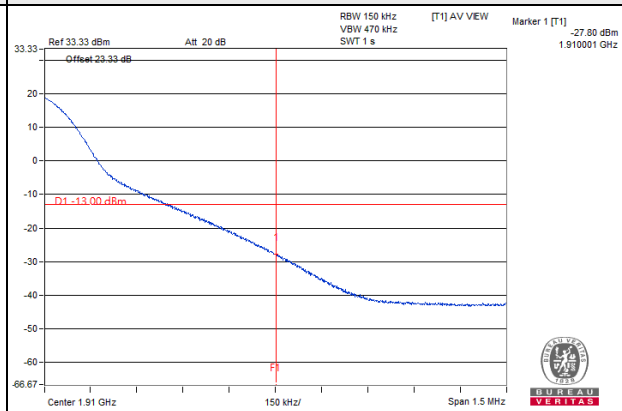

75 RB

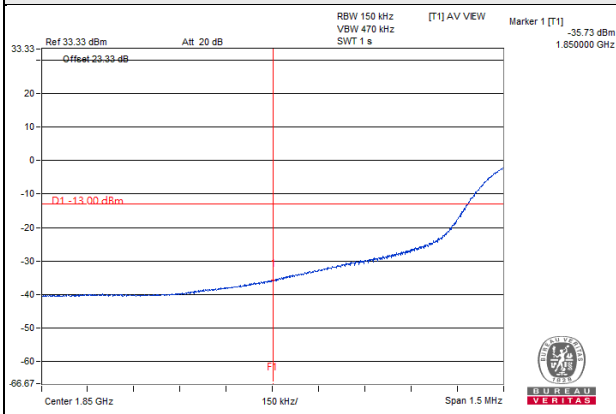

75 RB

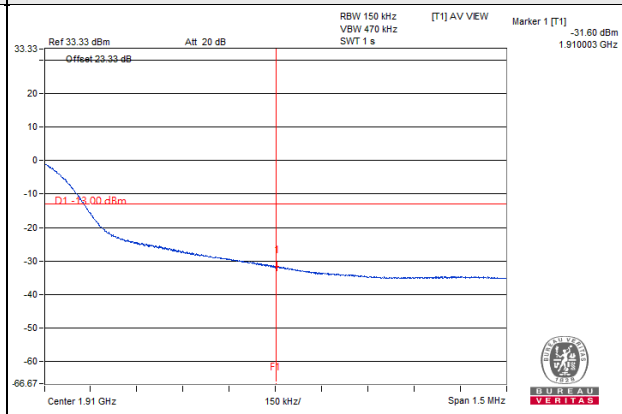

LTE Band 2 Channel Bandwidth: 20MHz

Channel 18700

1 RB

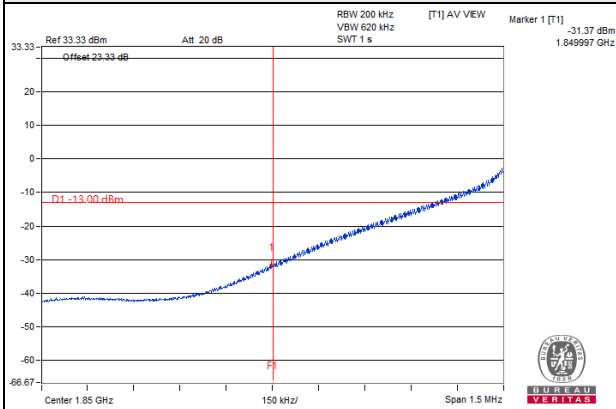

Channel 19100

1 RB

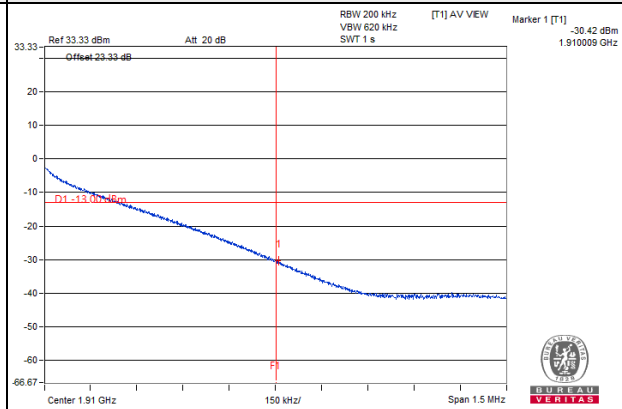

100 RB

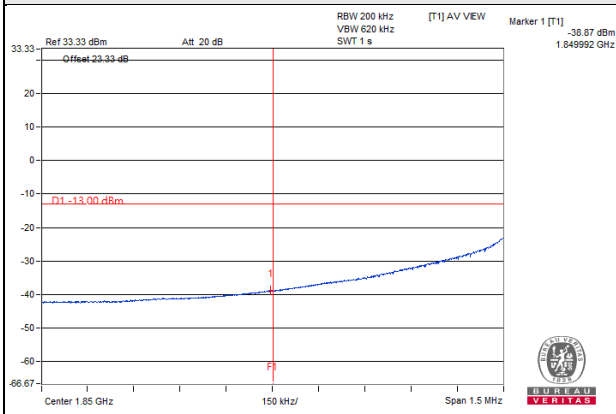

100 RB

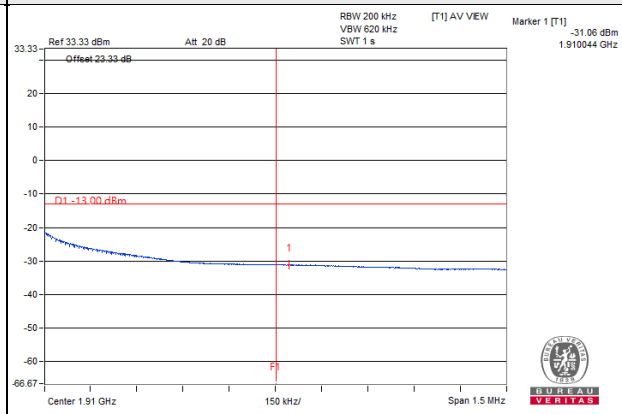

4.6 Peak to Average Ratio

4.5.1 Limits of Peak to Average Ratio Measurement

In measuring transmissions in this band using an average power technique, the peak to-average ratio (PAR) of the transmission may not exceed 13 dB

4.5.2 Test Setup

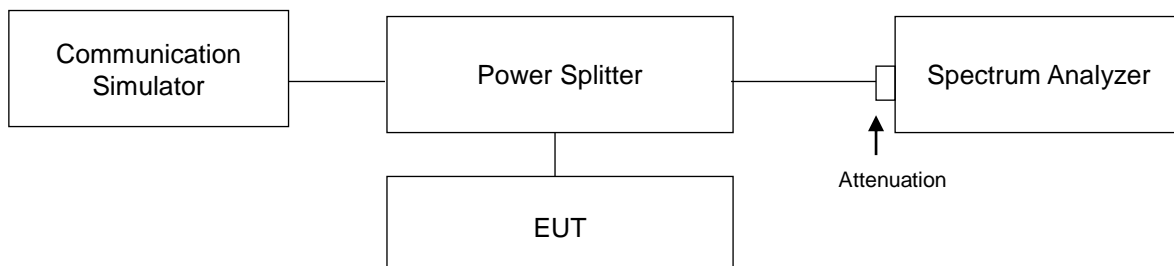

4.5.3 Test Procedures

1. Set resolution/measurement bandwidth \geq signal's occupied bandwidth;
2. Set the number of counts to a value that stabilizes the measured CCDF curve;
3. Record the maximum PAPR level associated with a probability of 0.1%.

4.5.4 Test Results

Channel	Freq. (MHz)	Peak to Average Ratio (dB)
		WCDMA B2
9262	1852.4	3.17
9400	1880	3.18
9538	1907.6	3.16

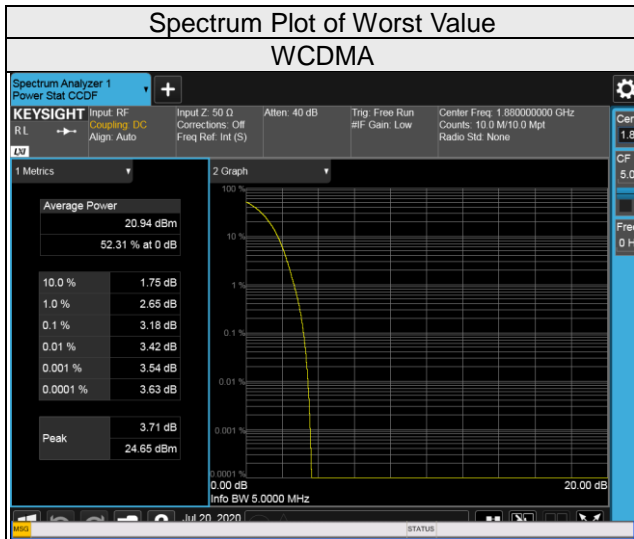

LTE Band 2							
Channel Bandwidth 1.4MHz				Channel Bandwidth 3MHz			
Channel	Frequency (MHz)	Peak To Average Ratio (dB)		Channel	Frequency (MHz)	Peak To Average Ratio (dB)	
		QPSK	16QAM			QPSK	16QAM
18607	1850.7	5.23	6.05	18615	1851.5	5.29	6.16
18900	1880	5.32	6.11	18900	1880	5.33	6.15
19193	1909.3	5.17	5.99	19185	1908.5	5.22	6.09
Channel Bandwidth 5MHz				Channel Bandwidth 10MHz			
Channel	Frequency (MHz)	Peak To Average Ratio (dB)		Channel	Frequency (MHz)	Peak To Average Ratio (dB)	
		QPSK	16QAM			QPSK	16QAM
18625	1852.5	5.38	6.19	18650	1855	5.35	6.21
18900	1880	5.35	6.18	18900	1880	5.31	6.10
19175	1907.5	5.28	6.11	19150	1905	5.25	6.06
Channel Bandwidth 15MHz				Channel Bandwidth 20MHz			
Channel	Frequency (MHz)	Peak To Average Ratio (dB)		Channel	Frequency (MHz)	Peak To Average Ratio (dB)	
		QPSK	16QAM			QPSK	16QAM
18675	1857.5	5.53	6.16	18700	1860	5.11	5.95
18900	1880	5.57	6.19	18900	1880	5.38	6.09
19125	1902.5	5.48	6.10	19100	1900	5.23	5.95

Spectrum Plot of Worst Value

1.4MHz / 16QAM

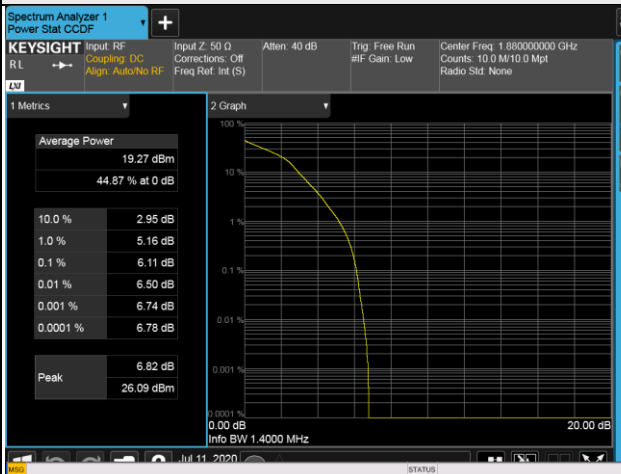

3MHz / 16QAM

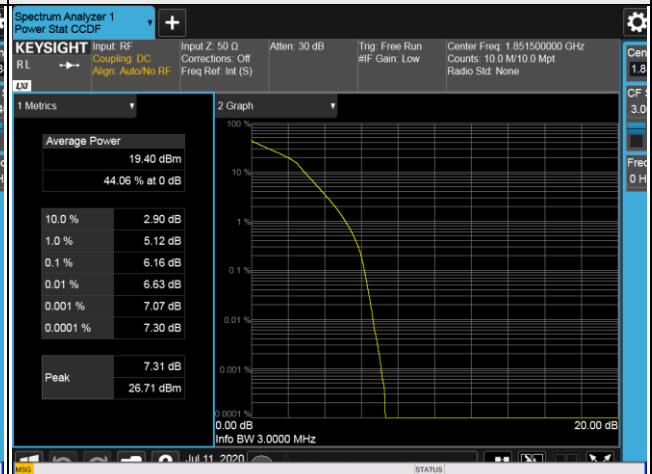

5MHz / 16QAM

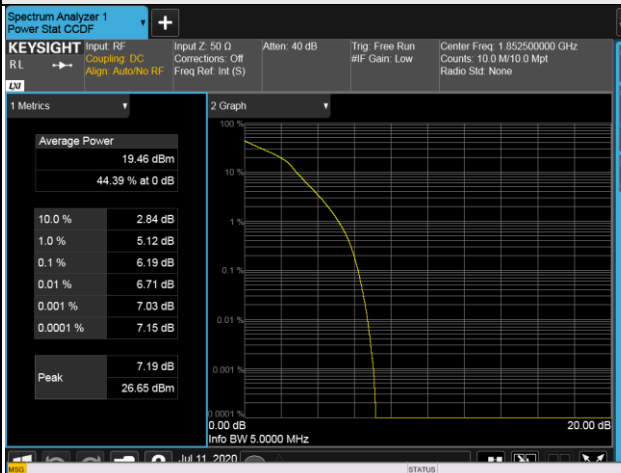

10MHz / 16QAM

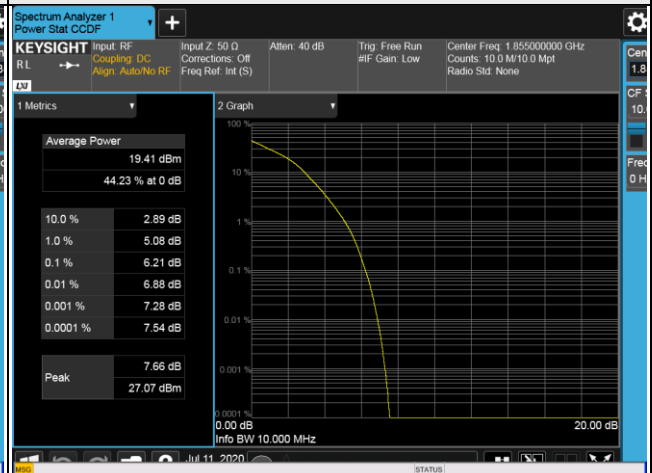

15MHz / 16QAM

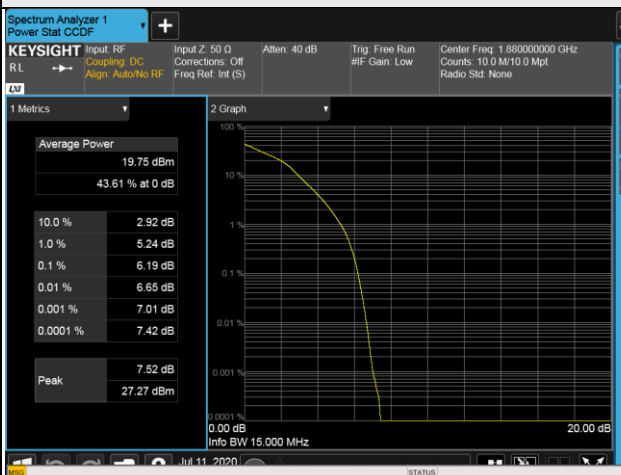

20MHz / 16QAM

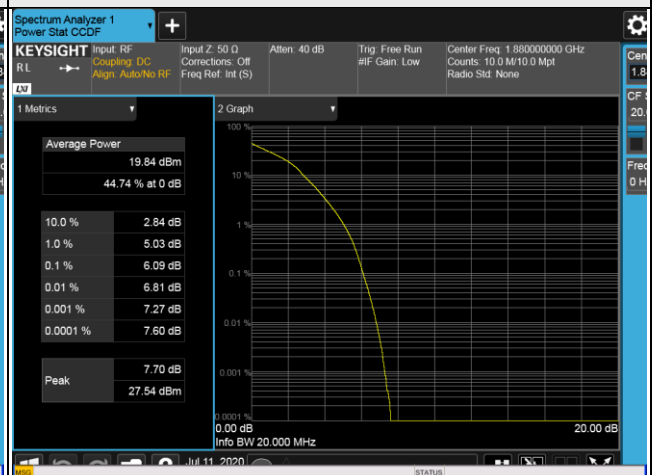

4.7 Conducted Spurious Emissions

4.7.1 Limits of Conducted Spurious Emissions Measurement

The power of any emission outside of the authorized operating frequency ranges must be attenuated below the transmitting power (P) by a factor of at least $43 + 10 \log(P)$ dB. The emission limit equal to -13dBm .

4.7.2 Test Setup

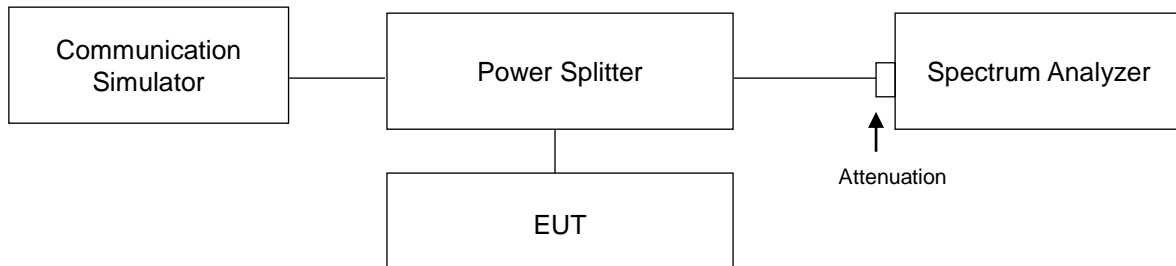

4.7.3 Test Procedure

- a. All measurements were done at middle operational frequency range.
- b. Measuring frequency range is from 9 kHz to the tenth harmonic of the highest fundamental frequency, it shall be connected to the pad attenuated the carried frequency.
RBW=1MHz and VBW=3MHz is used for conducted emission measurement.

4.7.4 Test Results

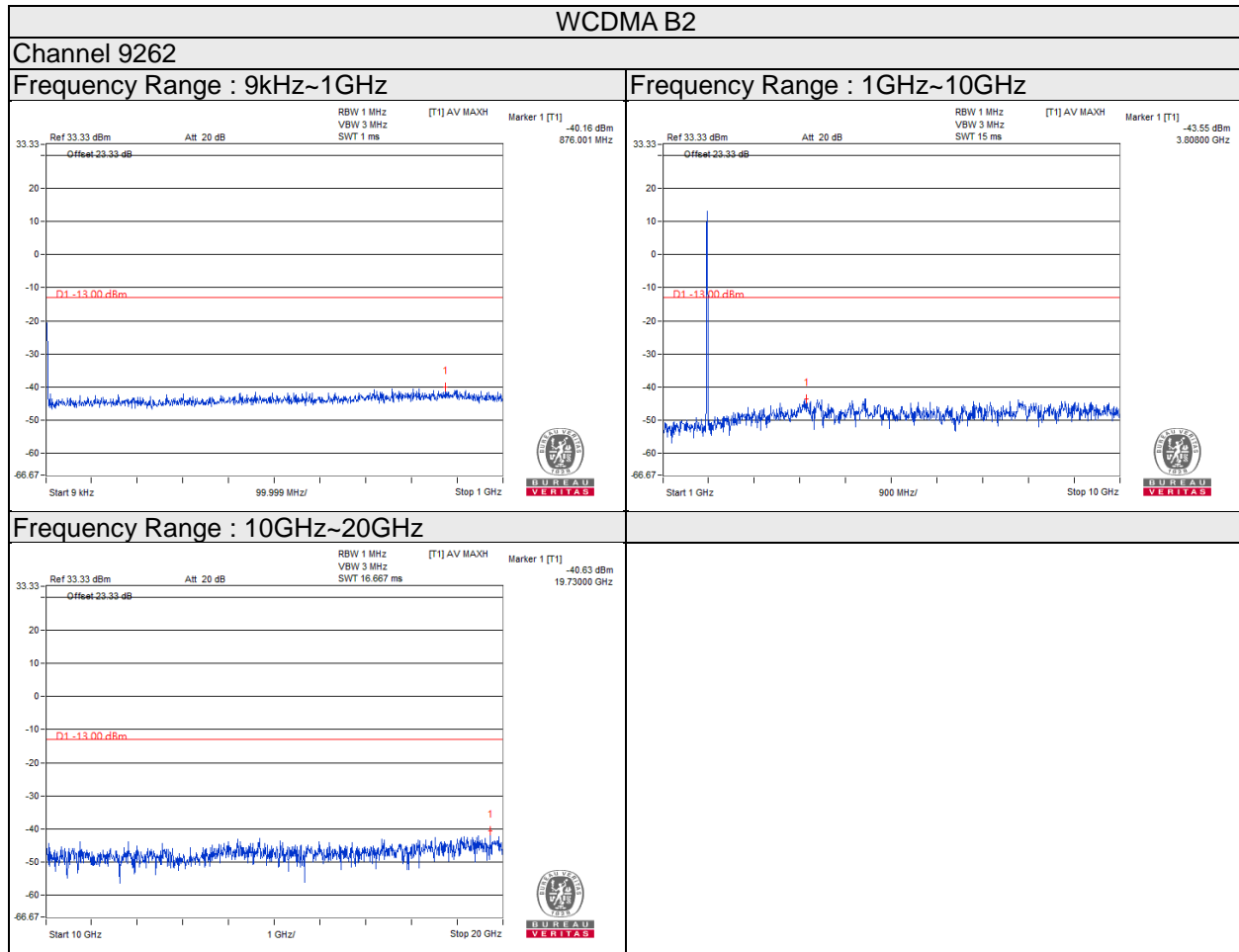

Note: The signal of 9kHz is IF signal from test instrument.

WCDMA B2

Channel 9400

Frequency Range : 9kHz~1GHz

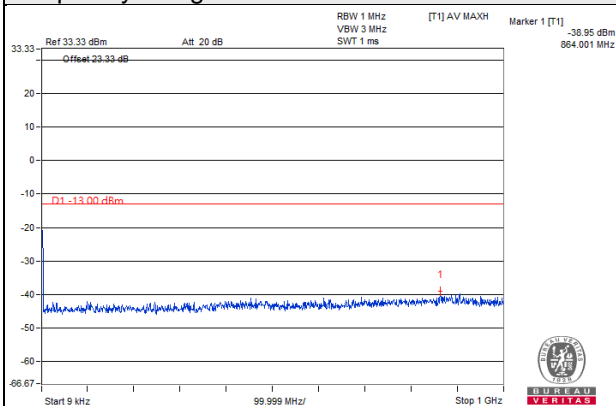

Frequency Range : 1GHz~10GHz

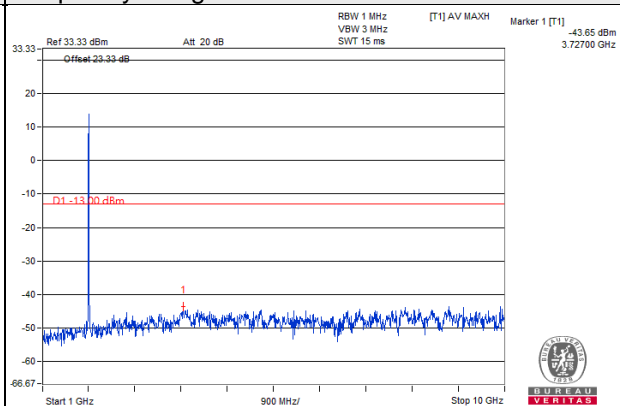

Frequency Range : 10GHz~20GHz

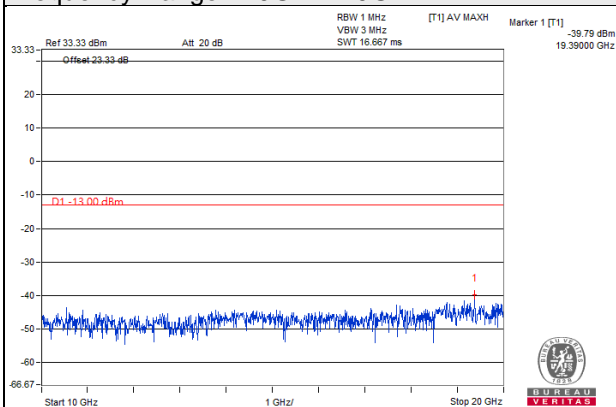

Note: The signal of 9kHz is IF signal from test instrument.

WCDMA B2

Channel 9538

Frequency Range : 9kHz~1GHz

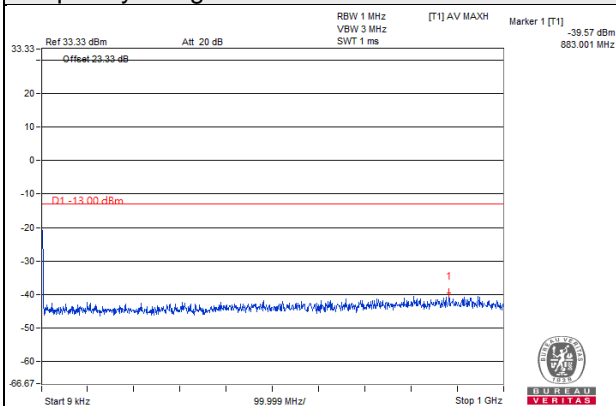

Frequency Range : 1GHz~10GHz

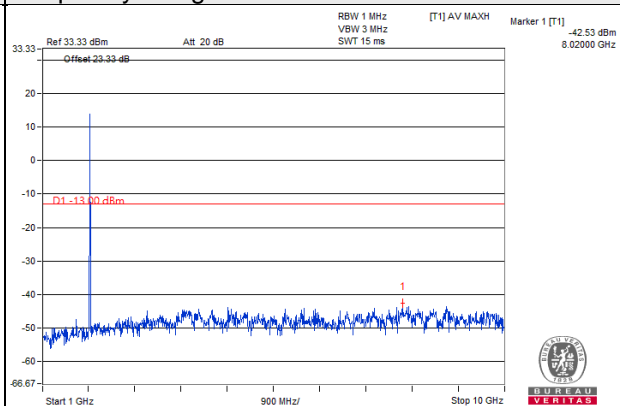

Frequency Range : 10GHz~20GHz

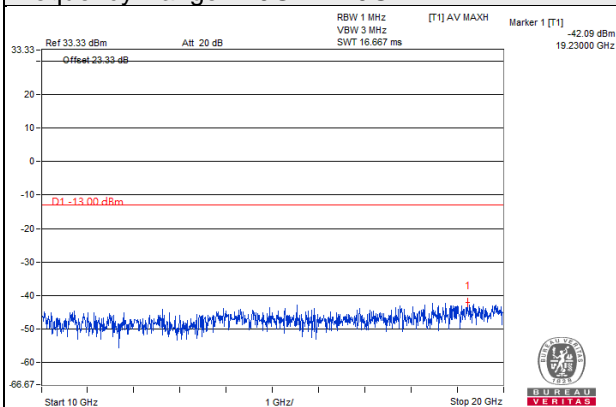

Note: The signal of 9kHz is IF signal from test instrument.

LTE Band 2 Channel Bandwidth: 1.4MHz

Channel 18607

Frequency Range : 9kHz~1GHz

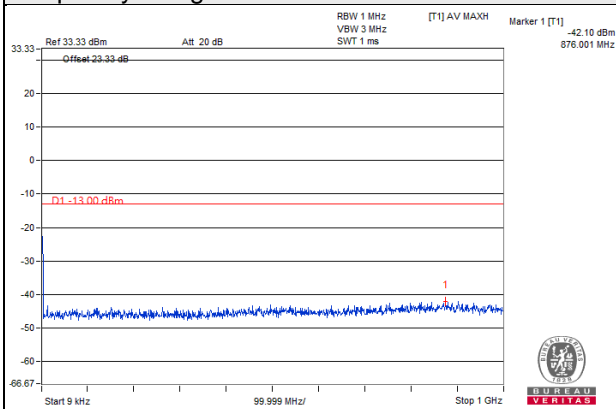

Frequency Range : 1GHz ~10GHz

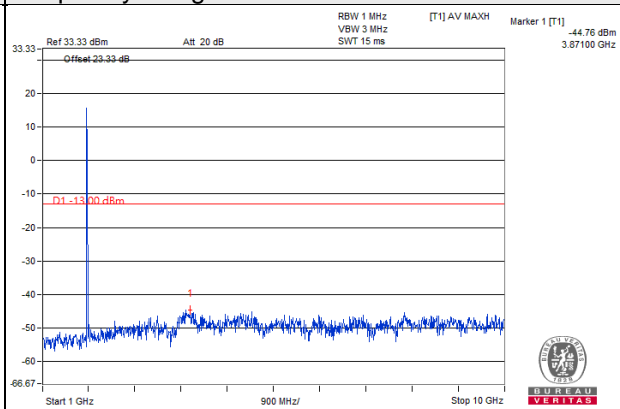

Frequency Range : 10GHz~20GHz

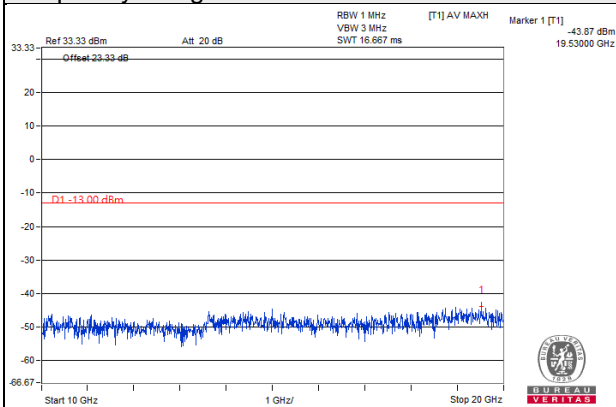

Note: The signal of 9kHz is IF signal from test instrument.

LTE Band 2 Channel Bandwidth: 1.4MHz

Channel 18900

Frequency Range : 9kHz~1GHz

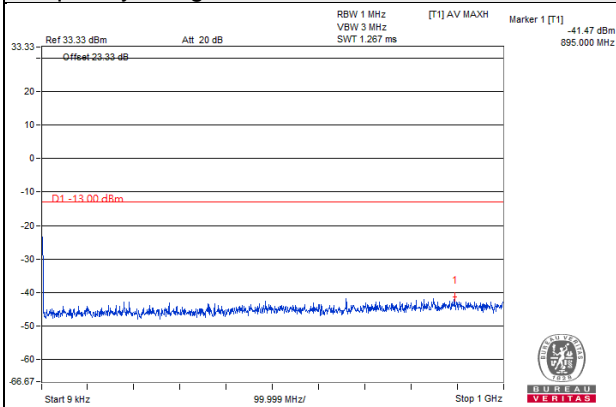

Frequency Range : 1GHz ~10GHz

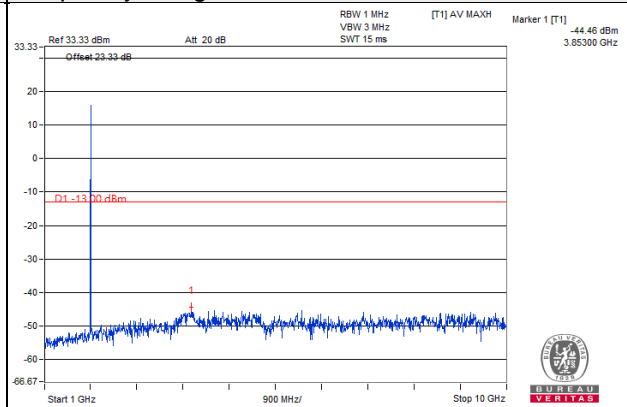

Frequency Range : 10GHz~20GHz

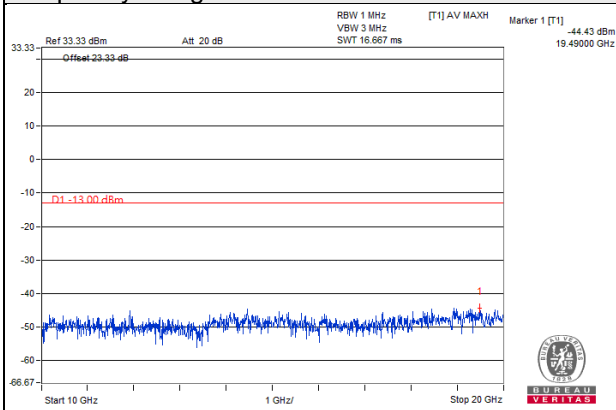

Note: The signal of 9kHz is IF signal from test instrument.

LTE Band 2 Channel Bandwidth: 1.4MHz
Channel 19193

Frequency Range : 9kHz~1GHz

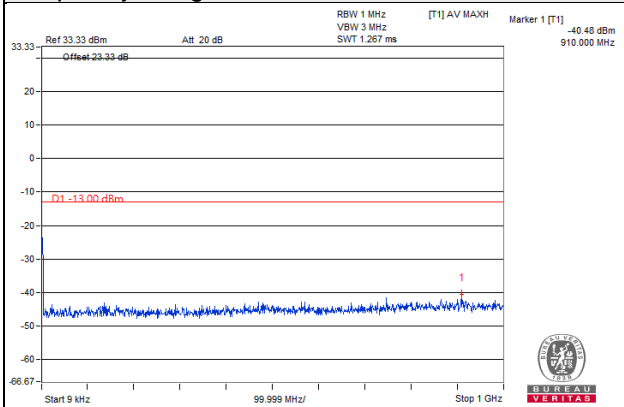

Frequency Range : 1GHz ~10GHz

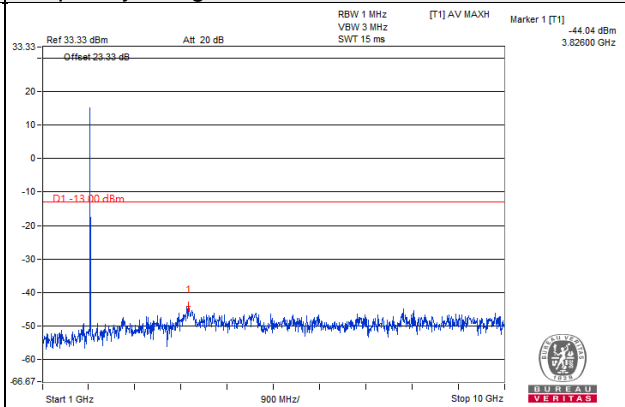

Frequency Range : 10GHz~20GHz

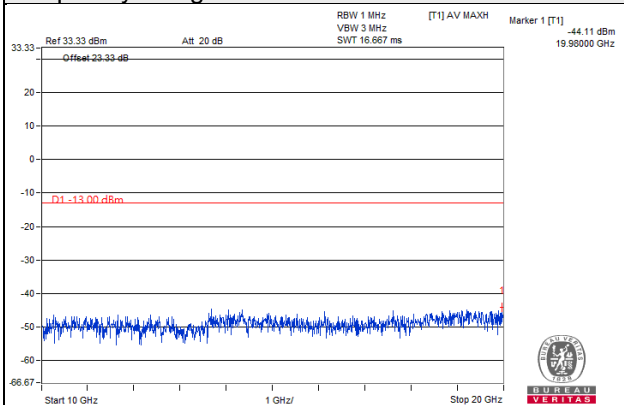

Note: The signal of 9kHz is IF signal from test instrument.

LTE Band 2 Channel Bandwidth: 3MHz

Channel 18615

Frequency Range : 9kHz~1GHz

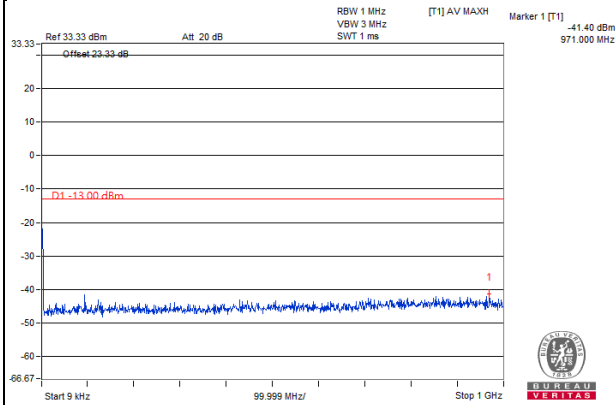

Frequency Range : 1GHz ~10GHz

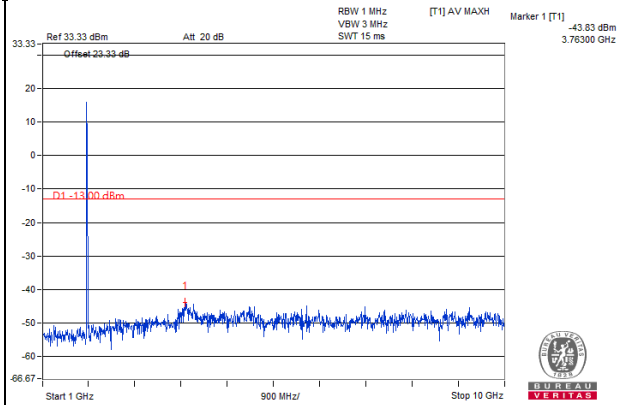

Frequency Range : 10GHz~20GHz

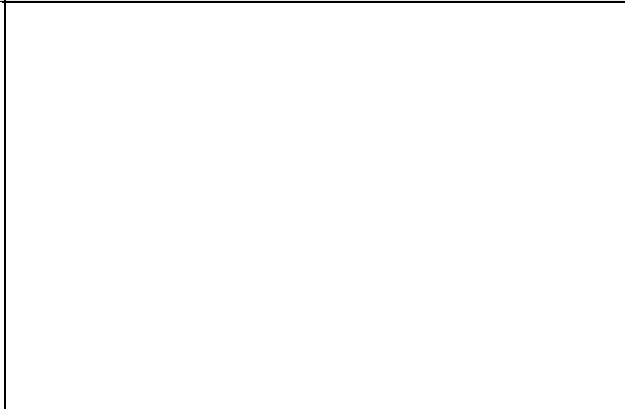
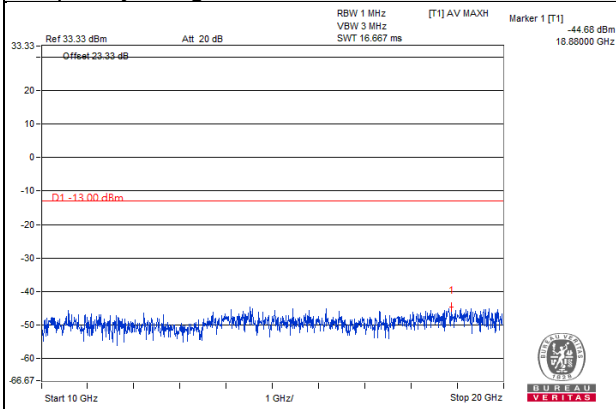

Note: The signal of 9kHz is IF signal from test instrument.

LTE Band 2 Channel Bandwidth: 3MHz

Channel 18900

Frequency Range : 9kHz~1GHz

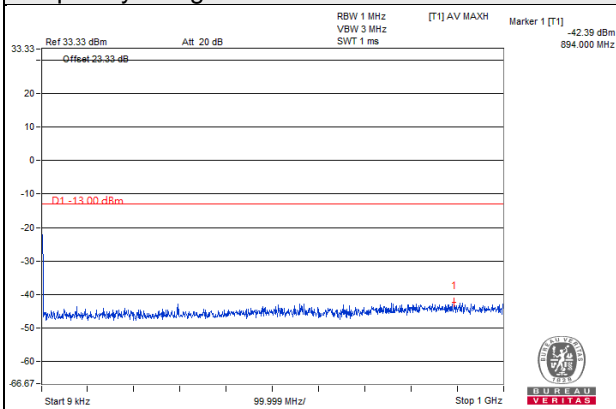

Frequency Range : 1GHz ~10GHz

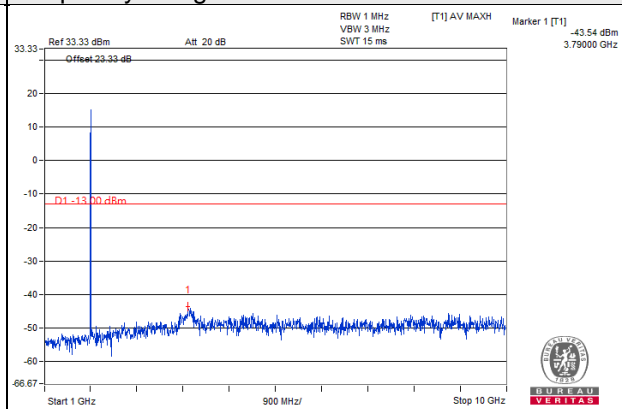

Frequency Range : 10GHz~20GHz

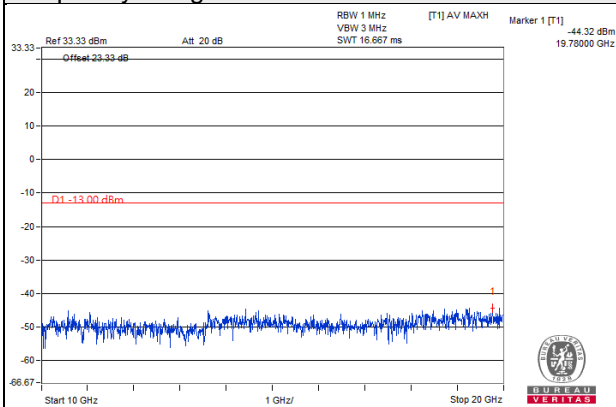

Note: The signal of 9kHz is IF signal from test instrument.

LTE Band 2 Channel Bandwidth: 3MHz

Channel 19185

Frequency Range : 9kHz~1GHz

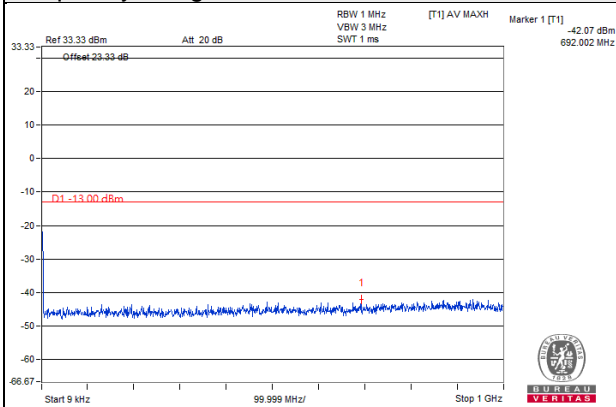

Frequency Range : 1GHz ~10GHz

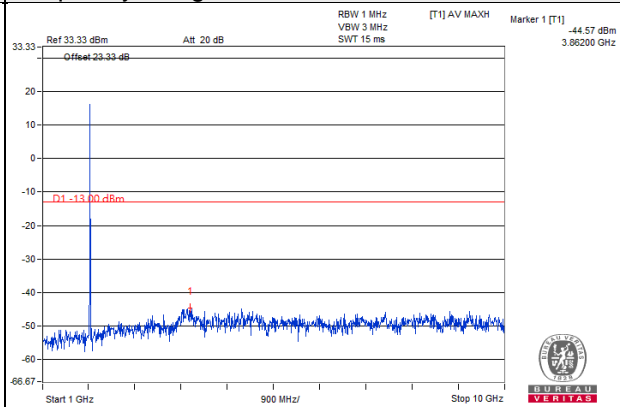

Frequency Range : 10GHz~20GHz

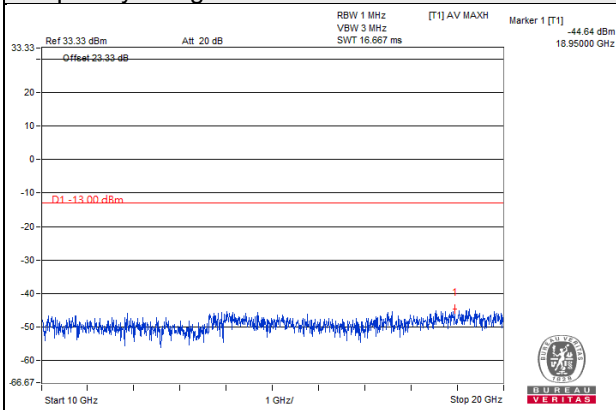

Note: The signal of 9kHz is IF signal from test instrument.

LTE Band 2 Channel Bandwidth: 5MHz

Channel 18625

Frequency Range : 9kHz~1GHz

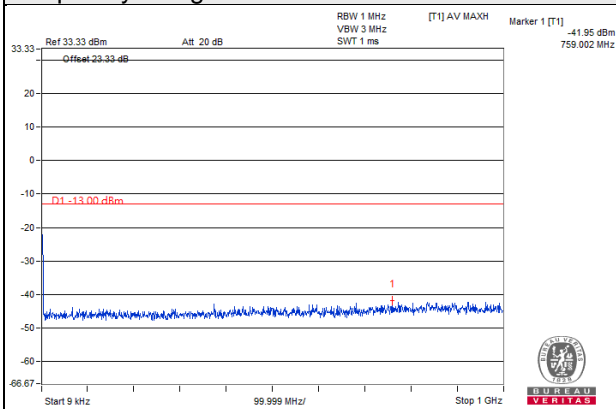

Frequency Range : 1GHz ~10GHz

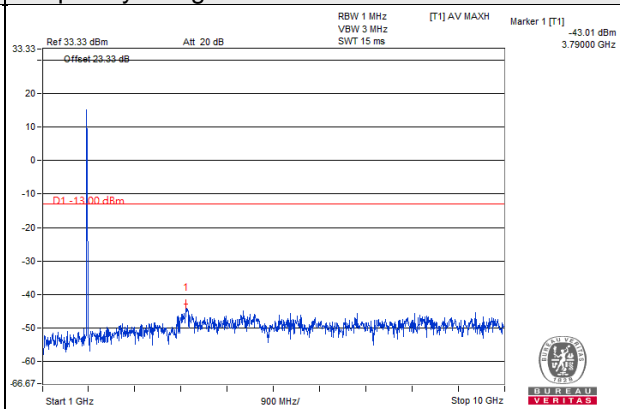

Frequency Range : 10GHz~20GHz

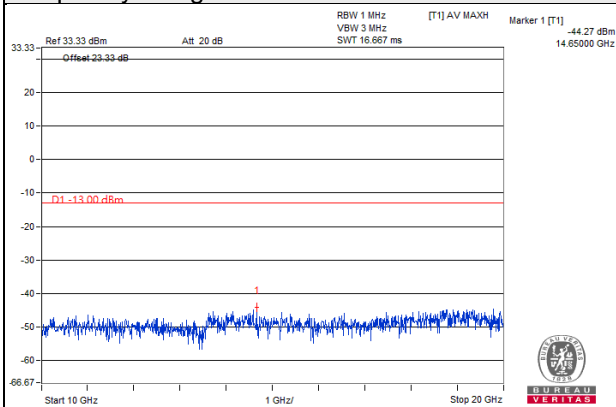

Note: The signal of 9kHz is IF signal from test instrument.

LTE Band 2 Channel Bandwidth: 5MHz

Channel 18900

Frequency Range : 9kHz~1GHz

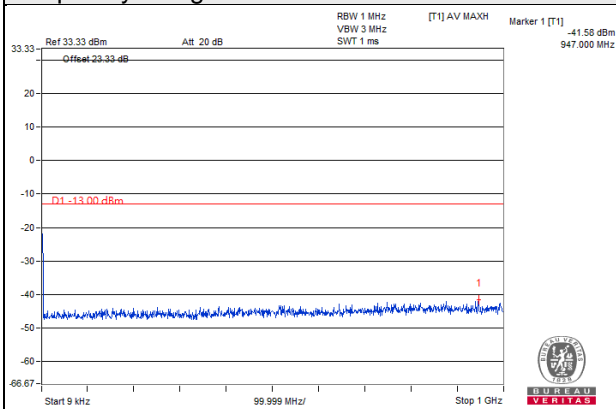

Frequency Range : 1GHz ~10GHz

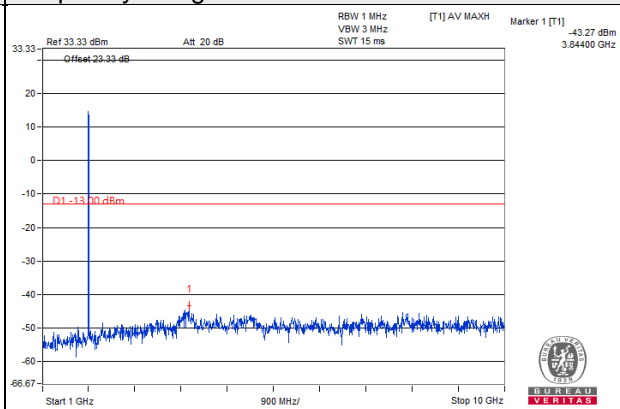

Frequency Range : 10GHz~20GHz

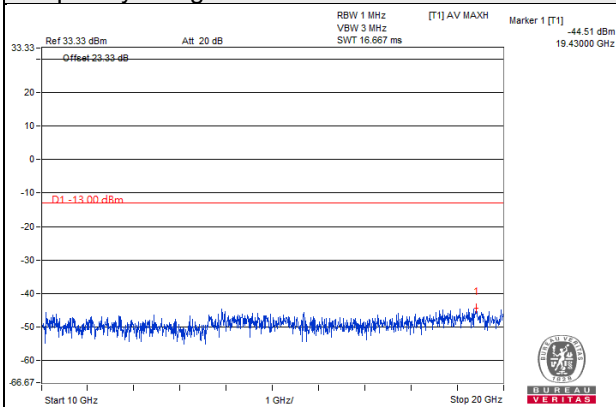

Note: The signal of 9kHz is IF signal from test instrument.

LTE Band 2 Channel Bandwidth: 5MHz

Channel 19175

Frequency Range : 9kHz~1GHz

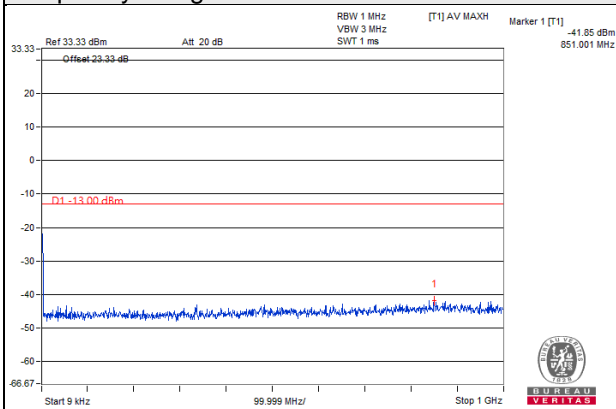

Frequency Range : 1GHz ~10GHz

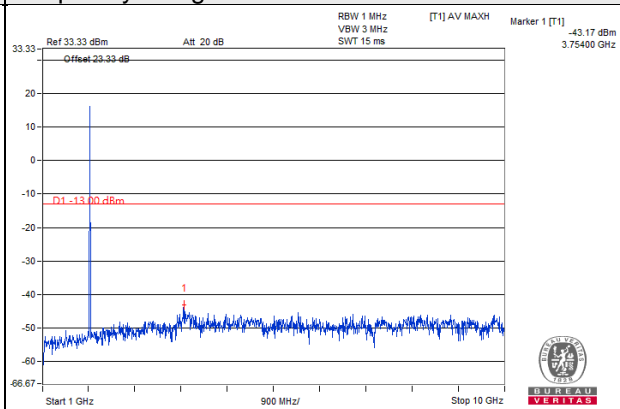

Frequency Range : 10GHz~20GHz

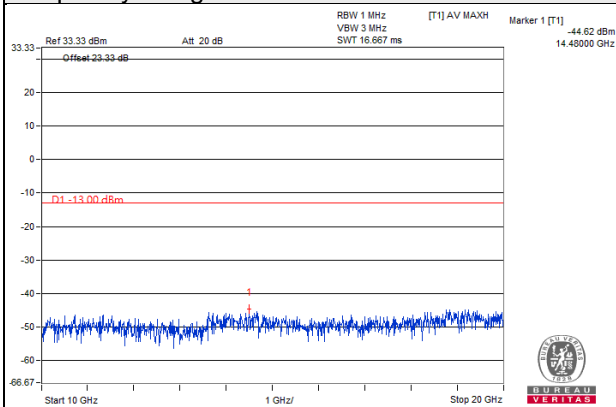

Note: The signal of 9kHz is IF signal from test instrument.

LTE Band 2 Channel Bandwidth: 10MHz

Channel 18650

Frequency Range : 9kHz~1GHz

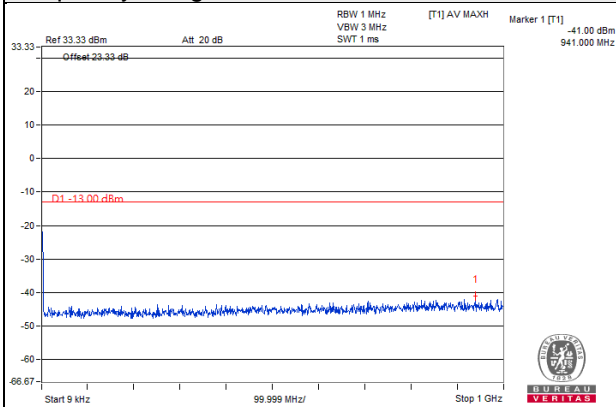

Frequency Range : 1GHz ~10GHz

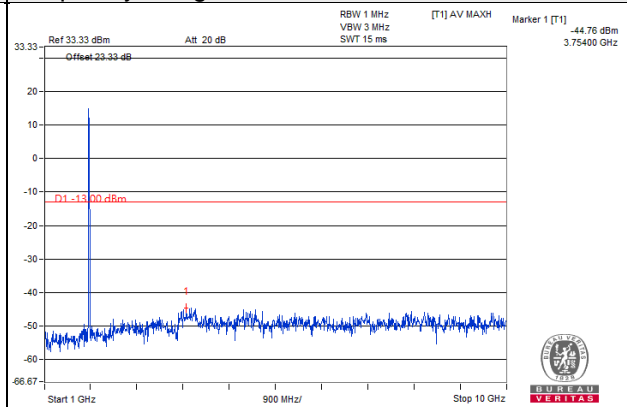

Frequency Range : 10GHz~20GHz

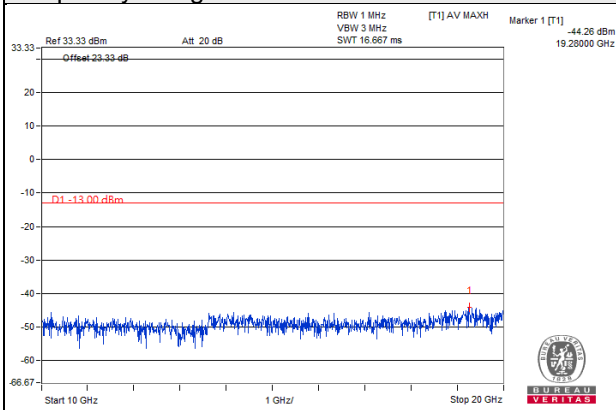

Note: The signal of 9kHz is IF signal from test instrument.

LTE Band 2 Channel Bandwidth: 10MHz
Channel 18900

Frequency Range : 9kHz~1GHz

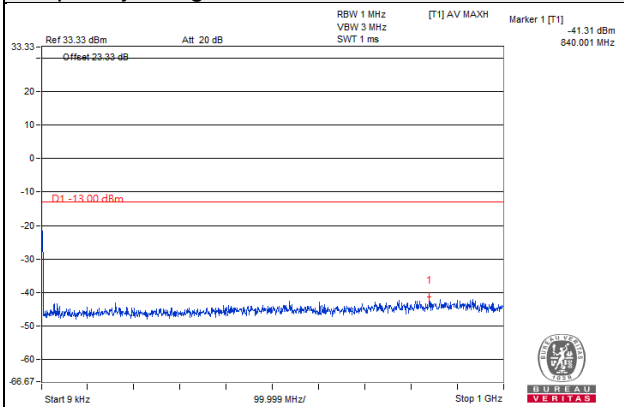

Frequency Range : 1GHz ~10GHz

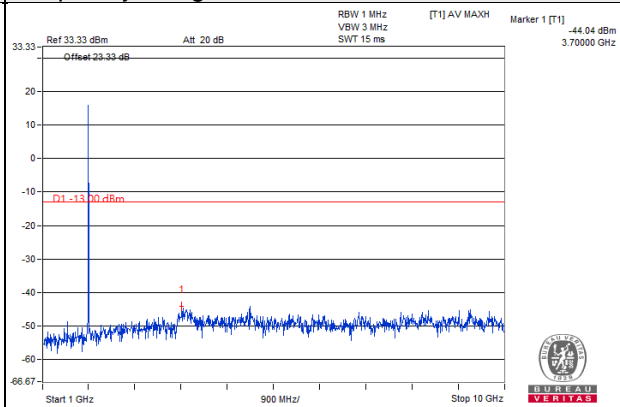

Frequency Range : 10GHz~20GHz

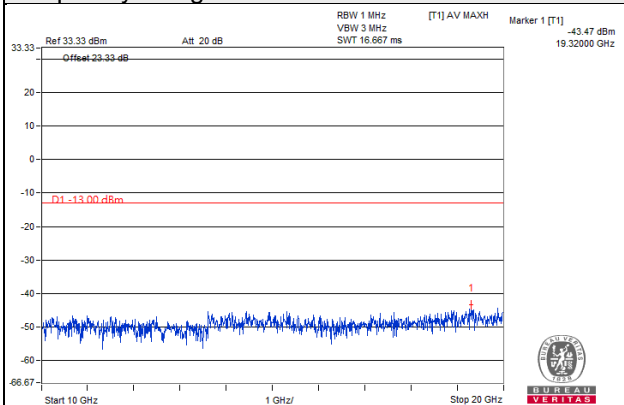

Note: The signal of 9kHz is IF signal from test instrument.

LTE Band 2 Channel Bandwidth: 10MHz

Channel 19150

Frequency Range : 9kHz~1GHz

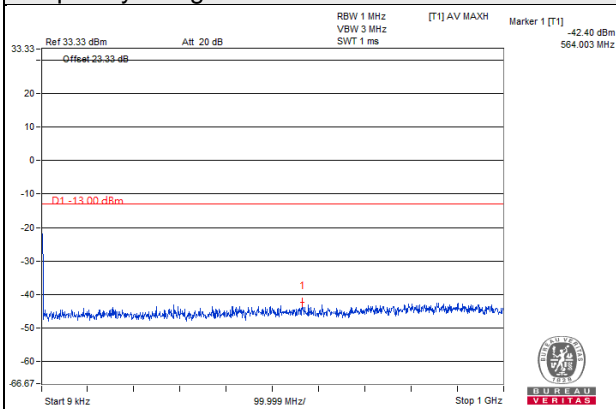

Frequency Range : 1GHz ~10GHz

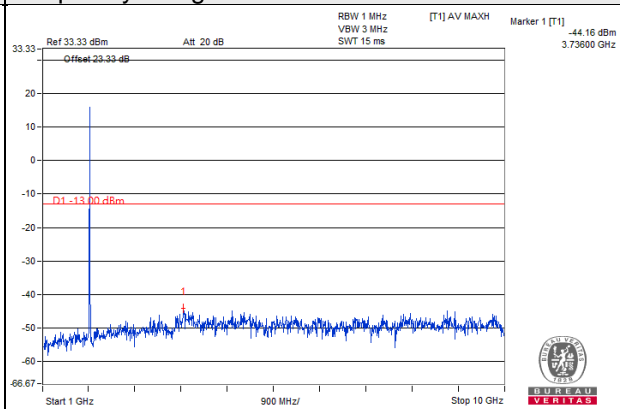

Frequency Range : 10GHz~20GHz

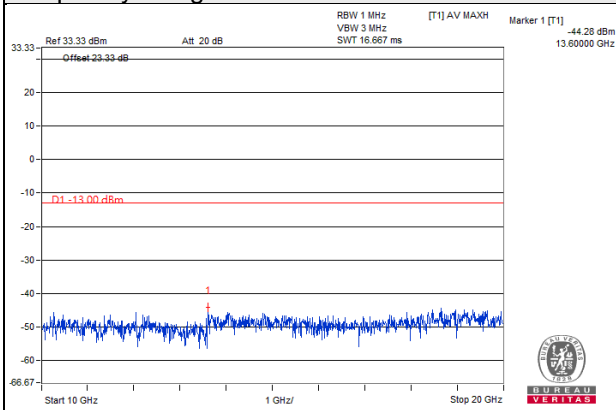

Note: The signal of 9kHz is IF signal from test instrument.

LTE Band 2 Channel Bandwidth: 15MHz

Channel 18675

Frequency Range : 9kHz~1GHz

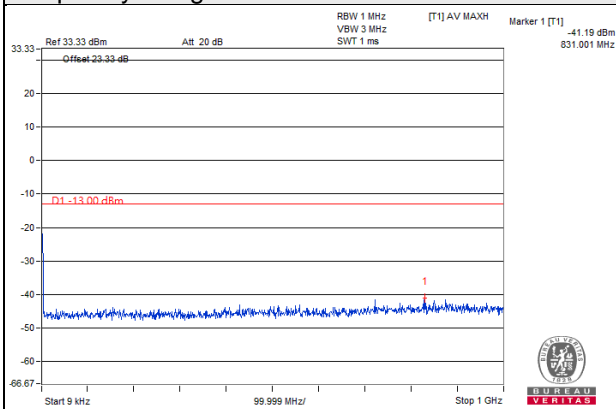

Frequency Range : 1GHz ~10GHz

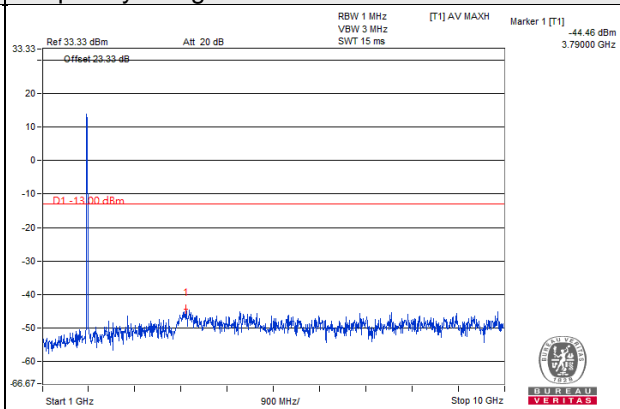

Frequency Range : 10GHz~20GHz

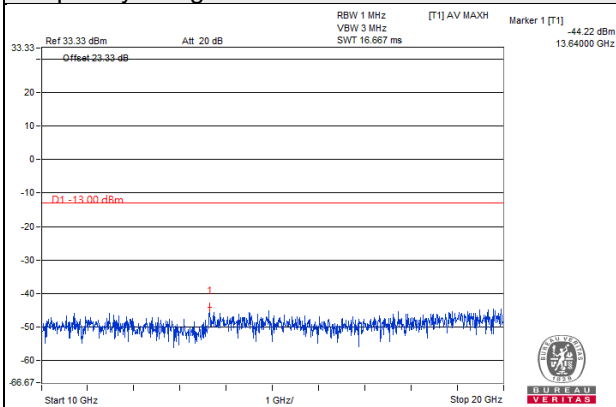

Note: The signal of 9kHz is IF signal from test instrument.

LTE Band 2 Channel Bandwidth: 15MHz
Channel 18900

Frequency Range : 9kHz~1GHz

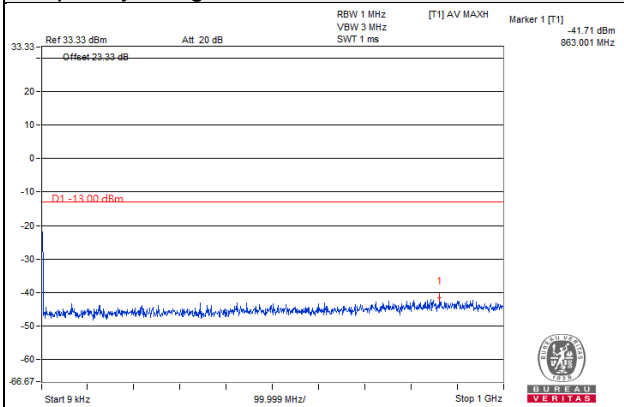

Frequency Range : 1GHz ~10GHz

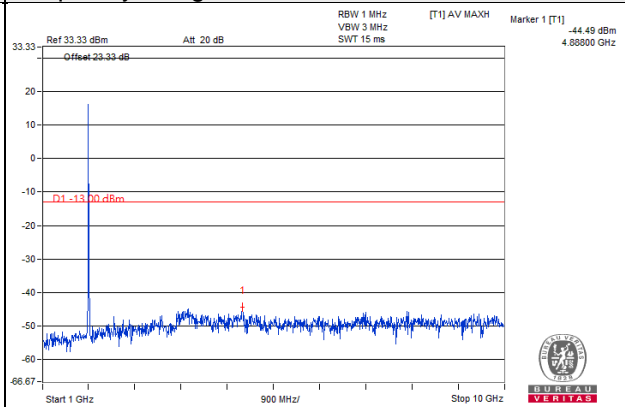

Frequency Range : 10GHz~20GHz

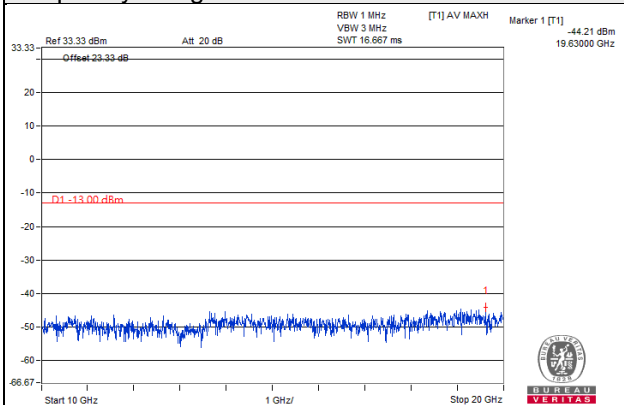

Note: The signal of 9kHz is IF signal from test instrument.

LTE Band 2 Channel Bandwidth: 15MHz

Channel 19125

Frequency Range : 9kHz~1GHz

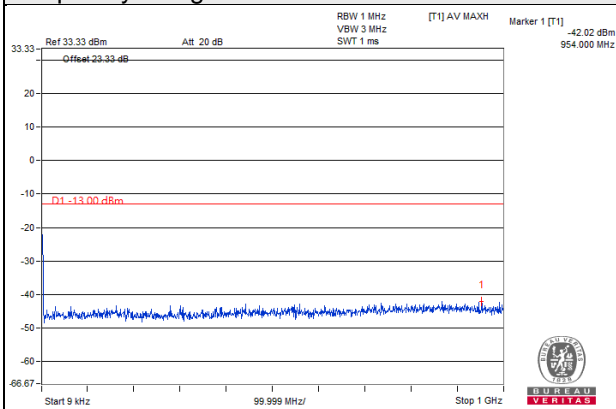

Frequency Range : 1GHz ~10GHz

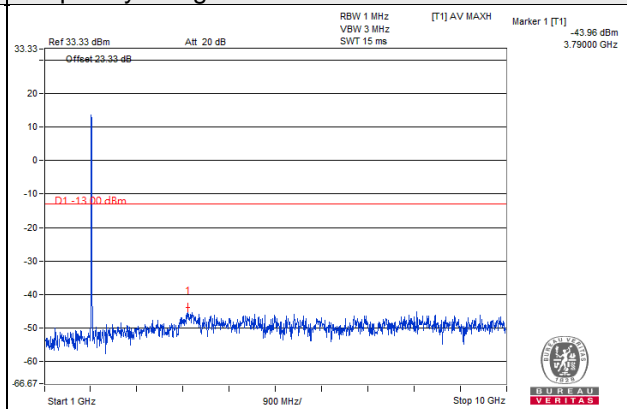

Frequency Range : 10GHz~20GHz

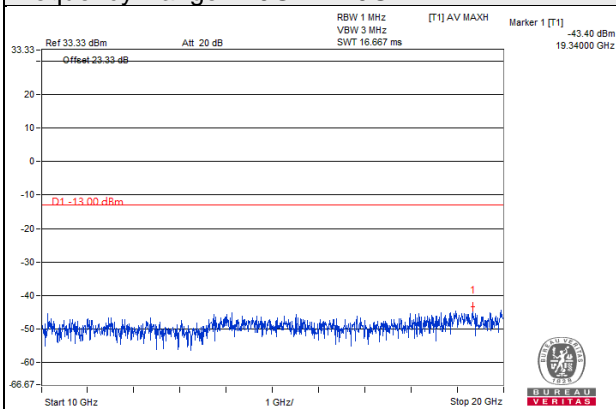

Note: The signal of 9kHz is IF signal from test instrument.

LTE Band 2 Channel Bandwidth: 20MHz

Channel 18700

Frequency Range : 9kHz~1GHz

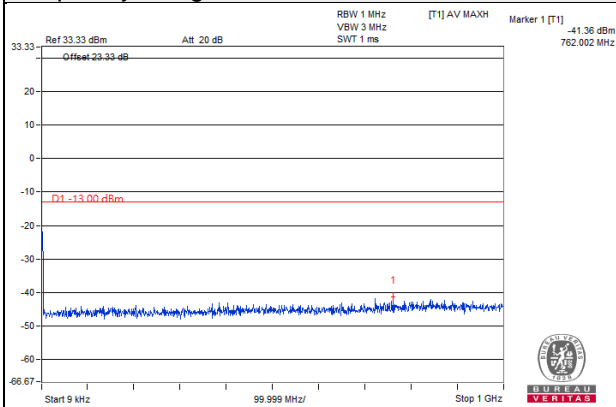

Frequency Range : 1GHz ~10GHz

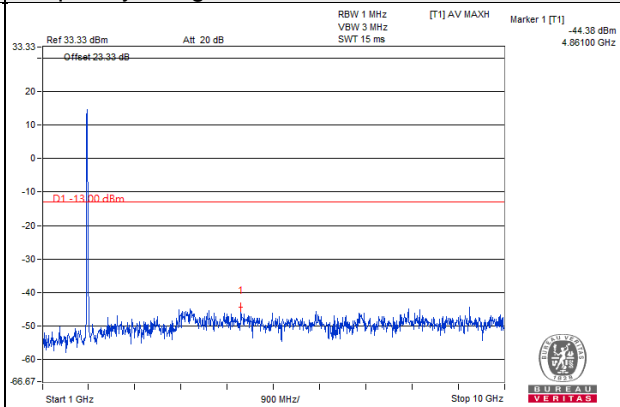

Frequency Range : 10GHz~20GHz

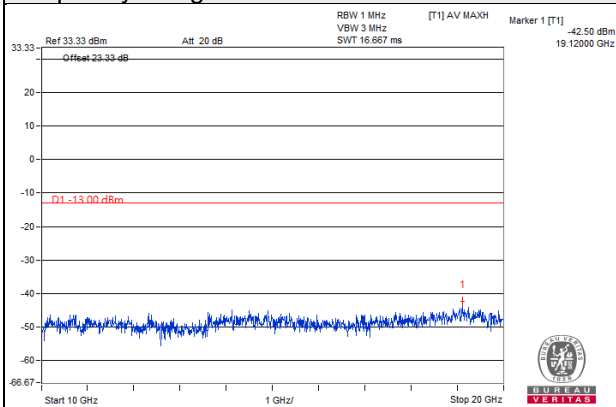

Note: The signal of 9kHz is IF signal from test instrument.

LTE Band 2 Channel Bandwidth: 20MHz

Channel 18900

Frequency Range : 9kHz~1GHz

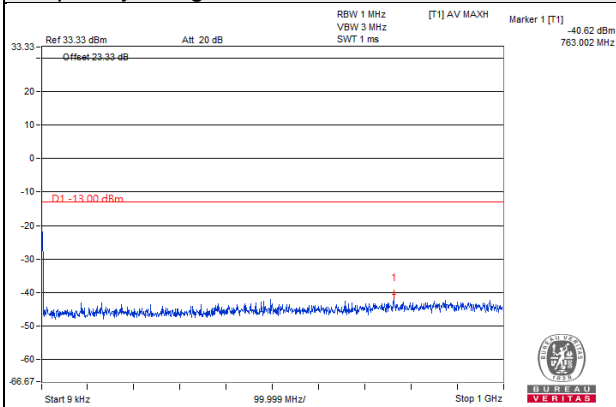

Frequency Range : 1GHz ~10GHz

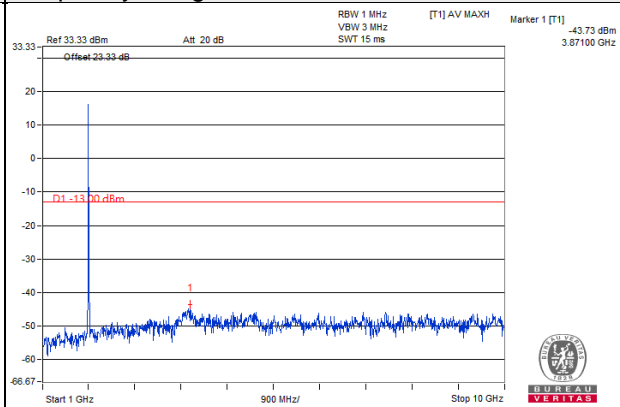

Frequency Range : 10GHz~20GHz

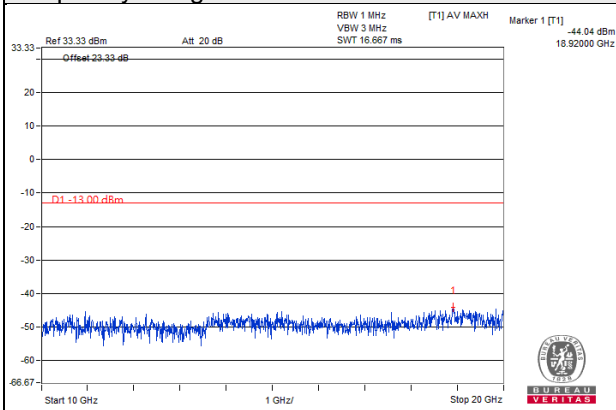

Note: The signal of 9kHz is IF signal from test instrument.

LTE Band 2 Channel Bandwidth: 20MHz

Channel 19100

Frequency Range : 9kHz~1GHz

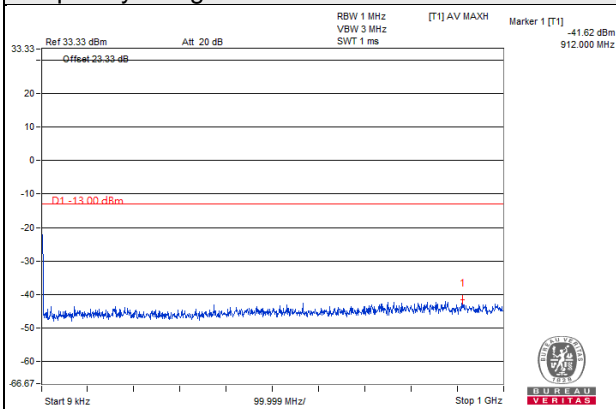

Frequency Range : 1GHz ~10GHz

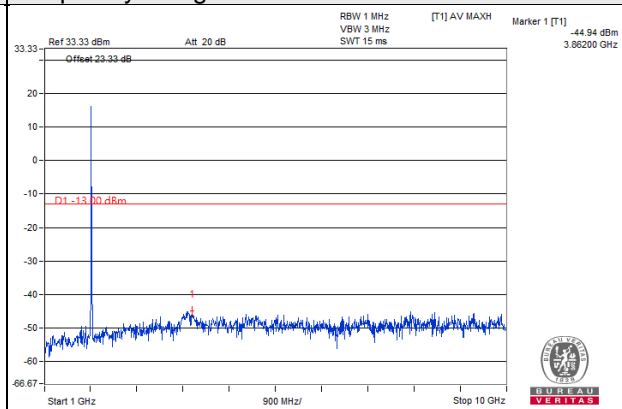

Frequency Range : 10GHz~20GHz

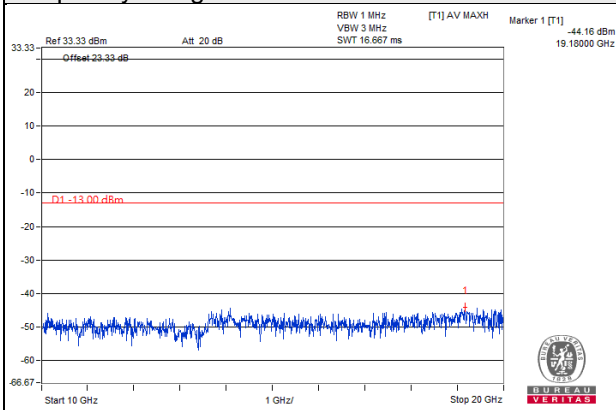

Note: The signal of 9kHz is IF signal from test instrument.

4.8 Radiated Emission Measurement

4.8.1 Limits of Radiated Emission Measurement

The power of any emission outside of the authorized operating frequency ranges must be attenuated below the transmitting power (P) by a factor of at least $43 + 10 \log(P)$ dB. The emission limit equal to -13dBm .

4.8.2 Test Procedure

- a. The power was measured with Spectrum Analyzer.
- b. Substitution method is used for EIRP measurement. In the semi-anechoic chamber, EUT placed on the 0.8m/1.5m height of Turn Table, rotated the table around 360 degrees to search the maximum radiation power and receiver antenna shall be rotated vertical and horizontal polarization and moved height from 1m to 4m to find the maximum polar radiated power. The "Read Value" is the spectrum reading the maximum power value.
- c. Follow ANSI 63.26 section 5.2.7 d), $\text{EIRP Value (dBm)} = \text{Read Value (dB}\mu\text{V/m)} - \text{Correction Factor @ 3m}$
- d. $\text{Correction Factor (dB) @ 3m} = 20\log(D) - 104.8$; where D is the measurement distance @3m $= -95.26\text{dB}$
- e. ERP power can be calculated form EIRP power by subtracting the gain of dipole, $\text{ERP power} = \text{EIPR power} - 2.15\text{dBi}$.

NOTE: The resolution bandwidth and video bandwidth of test receiver/spectrum analyzer is 1MHz/3MHz.

4.8.3 Deviation from Test Standard

No deviation.

4.8.4 Test Setup
For Below 1GHz:

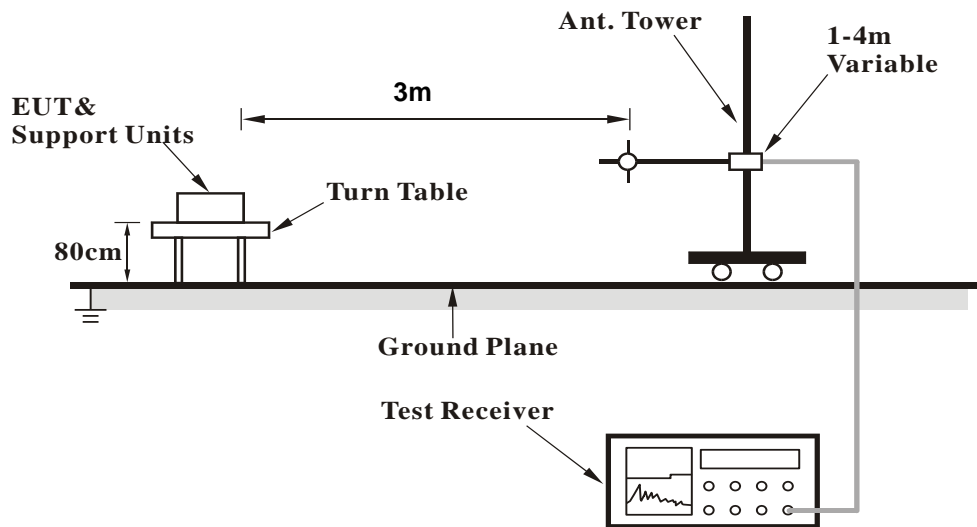

For Above 1GHz:

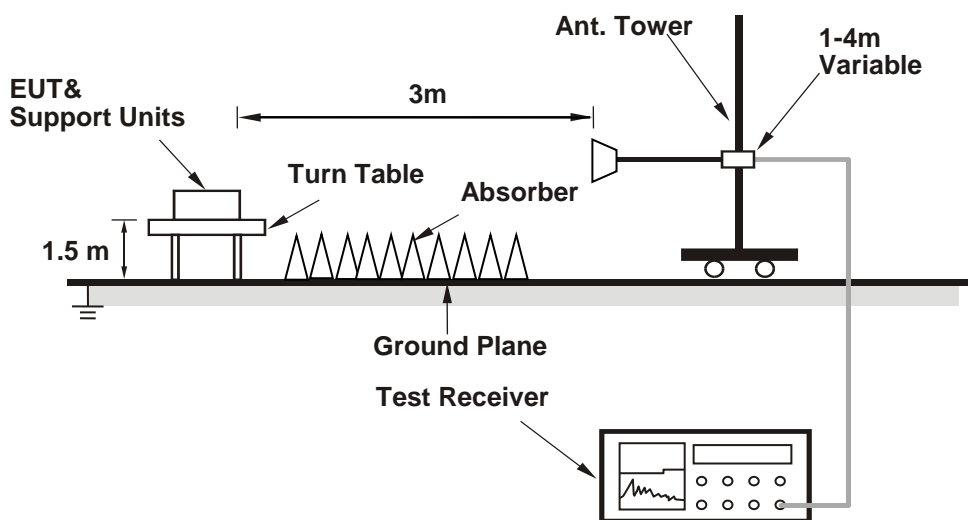

For the actual test configuration, please refer to the attached file (Test Setup Photo).

4.8.5 Test Results

Below 1GHz
WCDMA B2:

Mode	TX channel 9262	Frequency Range	Below 1000 MHz
------	-----------------	-----------------	----------------

Antenna Polarity & Test Distance: Horizontal at 3 M

No.	Freq. (MHz)	Reading (dB μ V/m)	Correction Factor (dB)	Emission Value (dBm)	Limit (dBm)	Margin (dB)
1	73.37	28.79	-95.26	-66.47	-13	-53.47
2	149.76	29.68	-95.26	-65.58	-13	-52.58
3	204.4	31.27	-95.26	-63.99	-13	-50.99
4	296.76	36.51	-95.26	-58.75	-13	-45.75
5	406.83	38.1	-95.26	-57.16	-13	-44.16
6	646.22	36.44	-95.26	-58.82	-13	-45.82

Antenna Polarity & Test Distance: Vertical at 3 M

No.	Freq. (MHz)	Reading (dB μ V/m)	Correction Factor (dB)	Emission Value (dBm)	Limit (dBm)	Margin (dB)
1	84.1	30.21	-95.26	-65.05	-13	-52.05
2	155	31.93	-95.26	-63.33	-13	-50.33
3	200.48	31.53	-95.26	-63.73	-13	-50.73
4	293.14	37.69	-95.26	-57.57	-13	-44.57
5	405.57	34.9	-95.26	-60.36	-13	-47.36
6	658.46	35.12	-95.26	-60.14	-13	-47.14

Remarks:

1. Follow ANSI 63.26 section 5.2.7 d), Emission Value (dBm) = E (dB μ V/m) - Correction Factor @ 3m.
2. Correction Factor (dB) = 20log(D) - 104.8; where D is the measurement distance @3m.

Mode	TX channel 9400	Frequency Range	Below 1000 MHz
------	-----------------	-----------------	----------------

Antenna Polarity & Test Distance: Horizontal at 3 M

No.	Freq. (MHz)	Reading (dB μ V/m)	Correction Factor (dB)	Emission Value (dBm)	Limit (dBm)	Margin (dB)
1	74.1	28.94	-95.26	-66.32	-13	-53.32
2	149.47	30.07	-95.26	-65.19	-13	-52.19
3	203.99	31.13	-95.26	-64.13	-13	-51.13
4	297.11	36.4	-95.26	-58.86	-13	-45.86
5	406.68	37.47	-95.26	-57.79	-13	-44.79
6	646.22	36.5	-95.26	-58.76	-13	-45.76

Antenna Polarity & Test Distance: Vertical at 3 M

No.	Freq. (MHz)	Reading (dB μ V/m)	Correction Factor (dB)	Emission Value (dBm)	Limit (dBm)	Margin (dB)
1	84.29	29.98	-95.26	-65.28	-13	-52.28
2	154.61	31.73	-95.26	-63.53	-13	-50.53
3	200.42	32.03	-95.26	-63.23	-13	-50.23
4	292.84	36.96	-95.26	-58.30	-13	-45.30
5	405.09	34.72	-95.26	-60.54	-13	-47.54
6	658.65	35.01	-95.26	-60.25	-13	-47.25

Remarks:

1. Follow ANSI 63.26 section 5.2.7 d), Emission Value (dBm) = E (dB μ V/m) - Correction Factor @ 3m.
2. Correction Factor (dB) = 20log(D) - 104.8; where D is the measurement distance @3m.

Mode	TX channel 9538	Frequency Range	Below 1000 MHz
------	-----------------	-----------------	----------------

Antenna Polarity & Test Distance: Horizontal at 3 M

No.	Freq. (MHz)	Reading (dB μ V/m)	Correction Factor (dB)	Emission Value (dBm)	Limit (dBm)	Margin (dB)
1	73.27	28.5	-95.26	-66.76	-13	-53.76
2	149.2	30.53	-95.26	-64.73	-13	-51.73
3	204.12	31.47	-95.26	-63.79	-13	-50.79
4	296.89	36.46	-95.26	-58.80	-13	-45.80
5	407.05	37.55	-95.26	-57.71	-13	-44.71
6	646.49	37.03	-95.26	-58.23	-13	-45.23

Antenna Polarity & Test Distance: Vertical at 3 M

No.	Freq. (MHz)	Reading (dB μ V/m)	Correction Factor (dB)	Emission Value (dBm)	Limit (dBm)	Margin (dB)
1	83.86	30.23	-95.26	-65.03	-13	-52.03
2	155.19	31.26	-95.26	-64.00	-13	-51.00
3	199.81	31.4	-95.26	-63.86	-13	-50.86
4	292.97	37.08	-95.26	-58.18	-13	-45.18
5	405.71	34.04	-95.26	-61.22	-13	-48.22
6	657.96	35.61	-95.26	-59.65	-13	-46.65

Remarks:

1. Follow ANSI 63.26 section 5.2.7 d), Emission Value (dBm) = E (dB μ V/m) - Correction Factor @ 3m.
2. Correction Factor (dB) = 20log(D) - 104.8; where D is the measurement distance @3m.

LTE Band 2: 1.4 MHz

Mode	TX channel 18607	Frequency Range	Below 1000 MHz
------	------------------	-----------------	----------------

Antenna Polarity & Test Distance: Horizontal at 3 M

No.	Freq. (MHz)	Reading (dB μ V/m)	Correction Factor (dB)	Emission Value (dBm)	Limit (dBm)	Margin (dB)
1	73.65	28.55	-95.26	-66.71	-13	-53.71
2	149.66	30.12	-95.26	-65.14	-13	-52.14
3	204.32	31.04	-95.26	-64.22	-13	-51.22
4	296.73	36.13	-95.26	-59.13	-13	-46.13
5	406.8	37.66	-95.26	-57.60	-13	-44.60
6	646.15	36.85	-95.26	-58.41	-13	-45.41

Antenna Polarity & Test Distance: Vertical at 3 M

No.	Freq. (MHz)	Reading (dB μ V/m)	Correction Factor (dB)	Emission Value (dBm)	Limit (dBm)	Margin (dB)
1	84.01	29.87	-95.26	-65.39	-13	-52.39
2	154.71	31.5	-95.26	-63.76	-13	-50.76
3	200.23	31.84	-95.26	-63.42	-13	-50.42
4	293.21	37.34	-95.26	-57.92	-13	-44.92
5	405.57	34.41	-95.26	-60.85	-13	-47.85
6	658.25	35.28	-95.26	-59.98	-13	-46.98

Remarks:

1. Follow ANSI 63.26 section 5.2.7 d), Emission Value (dBm) = E (dB μ V/m) - Correction Factor @ 3m.
2. Correction Factor (dB) = 20log(D) – 104.8; where D is the measurement distance @3m.

Mode	TX channel 18900	Frequency Range	Below 1000 MHz
------	------------------	-----------------	----------------

Antenna Polarity & Test Distance: Horizontal at 3 M

No.	Freq. (MHz)	Reading (dB μ V/m)	Correction Factor (dB)	Emission Value (dBm)	Limit (dBm)	Margin (dB)
1	73.97	28.71	-95.26	-66.55	-13	-53.55
2	149.93	30.38	-95.26	-64.88	-13	-51.88
3	203.99	30.68	-95.26	-64.58	-13	-51.58
4	296.66	36.53	-95.26	-58.73	-13	-45.73
5	407.14	37.73	-95.26	-57.53	-13	-44.53
6	645.73	36.98	-95.26	-58.28	-13	-45.28

Antenna Polarity & Test Distance: Vertical at 3 M

No.	Freq. (MHz)	Reading (dB μ V/m)	Correction Factor (dB)	Emission Value (dBm)	Limit (dBm)	Margin (dB)
1	83.85	29.74	-95.26	-65.52	-13	-52.52
2	154.68	31.62	-95.26	-63.64	-13	-50.64
3	200.04	32.14	-95.26	-63.12	-13	-50.12
4	292.91	37.39	-95.26	-57.87	-13	-44.87
5	406	34.36	-95.26	-60.90	-13	-47.90
6	658.56	35.27	-95.26	-59.99	-13	-46.99

Remarks:

1. Follow ANSI 63.26 section 5.2.7 d), Emission Value (dBm) = E (dB μ V/m) - Correction Factor @ 3m.
2. Correction Factor (dB) = 20log(D) - 104.8; where D is the measurement distance @3m.

Mode	TX channel 19193	Frequency Range	Below 1000 MHz
------	------------------	-----------------	----------------

Antenna Polarity & Test Distance: Horizontal at 3 M

No.	Freq. (MHz)	Reading (dB μ V/m)	Correction Factor (dB)	Emission Value (dBm)	Limit (dBm)	Margin (dB)
1	74.07	28.05	-95.26	-67.21	-13	-54.21
2	149.33	30.3	-95.26	-64.96	-13	-51.96
3	204.41	31.36	-95.26	-63.90	-13	-50.90
4	296.51	35.96	-95.26	-59.30	-13	-46.30
5	407.06	37.32	-95.26	-57.94	-13	-44.94
6	646.43	37.21	-95.26	-58.05	-13	-45.05

Antenna Polarity & Test Distance: Vertical at 3 M

No.	Freq. (MHz)	Reading (dB μ V/m)	Correction Factor (dB)	Emission Value (dBm)	Limit (dBm)	Margin (dB)
1	83.84	29.44	-95.26	-65.82	-13	-52.82
2	154.67	31.63	-95.26	-63.63	-13	-50.63
3	200.64	31.5	-95.26	-63.76	-13	-50.76
4	292.78	37.38	-95.26	-57.88	-13	-44.88
5	405.77	34.6	-95.26	-60.66	-13	-47.66
6	658.03	35.1	-95.26	-60.16	-13	-47.16

Remarks:

1. Follow ANSI 63.26 section 5.2.7 d), Emission Value (dBm) = E (dB μ V/m) - Correction Factor @ 3m.
2. Correction Factor (dB) = 20log(D) - 104.8; where D is the measurement distance @3m.

LTE Band 2: 3 MHz

Mode	TX channel 18615	Frequency Range	Below 1000 MHz
------	------------------	-----------------	----------------

Antenna Polarity & Test Distance: Horizontal at 3 M

No.	Freq. (MHz)	Reading (dB μ V/m)	Correction Factor (dB)	Emission Value (dBm)	Limit (dBm)	Margin (dB)
1	73.48	28.91	-95.26	-66.35	-13	-53.35
2	149.56	30.26	-95.26	-65.00	-13	-52.00
3	203.88	30.73	-95.26	-64.53	-13	-51.53
4	296.65	35.65	-95.26	-59.61	-13	-46.61
5	407.01	38.07	-95.26	-57.19	-13	-44.19
6	646.19	36.88	-95.26	-58.38	-13	-45.38

Antenna Polarity & Test Distance: Vertical at 3 M

No.	Freq. (MHz)	Reading (dB μ V/m)	Correction Factor (dB)	Emission Value (dBm)	Limit (dBm)	Margin (dB)
1	83.99	29.49	-95.26	-65.77	-13	-52.77
2	154.9	31.9	-95.26	-63.36	-13	-50.36
3	200.02	31.69	-95.26	-63.57	-13	-50.57
4	292.82	37.1	-95.26	-58.16	-13	-45.16
5	405.53	34.65	-95.26	-60.61	-13	-47.61
6	657.89	35.6	-95.26	-59.66	-13	-46.66

Remarks:

1. Follow ANSI 63.26 section 5.2.7 d), Emission Value (dBm) = E (dB μ V/m) - Correction Factor @ 3m.
2. Correction Factor (dB) = 20log(D) – 104.8; where D is the measurement distance @3m.

Mode	TX channel 18900	Frequency Range	Below 1000 MHz
------	------------------	-----------------	----------------

Antenna Polarity & Test Distance: Horizontal at 3 M

No.	Freq. (MHz)	Reading (dB μ V/m)	Correction Factor (dB)	Emission Value (dBm)	Limit (dBm)	Margin (dB)
1	74.03	28.47	-95.26	-66.79	-13	-53.79
2	149.36	29.96	-95.26	-65.30	-13	-52.30
3	203.83	30.61	-95.26	-64.65	-13	-51.65
4	296.62	35.97	-95.26	-59.29	-13	-46.29
5	406.43	38.1	-95.26	-57.16	-13	-44.16
6	646.42	36.88	-95.26	-58.38	-13	-45.38

Antenna Polarity & Test Distance: Vertical at 3 M

No.	Freq. (MHz)	Reading (dB μ V/m)	Correction Factor (dB)	Emission Value (dBm)	Limit (dBm)	Margin (dB)
1	84.38	29.66	-95.26	-65.60	-13	-52.60
2	154.23	31.24	-95.26	-64.02	-13	-51.02
3	200.17	32.07	-95.26	-63.19	-13	-50.19
4	293.47	37.52	-95.26	-57.74	-13	-44.74
5	405.92	34.47	-95.26	-60.79	-13	-47.79
6	658.6	35.65	-95.26	-59.61	-13	-46.61

Remarks:

1. Follow ANSI 63.26 section 5.2.7 d), Emission Value (dBm) = E (dB μ V/m) - Correction Factor @ 3m.
2. Correction Factor (dB) = 20log(D) - 104.8; where D is the measurement distance @3m.

Mode	TX channel 19185	Frequency Range	Below 1000 MHz
------	------------------	-----------------	----------------

Antenna Polarity & Test Distance: Horizontal at 3 M

No.	Freq. (MHz)	Reading (dB μ V/m)	Correction Factor (dB)	Emission Value (dBm)	Limit (dBm)	Margin (dB)
1	73.79	29.05	-95.26	-66.21	-13	-53.21
2	149.69	30.48	-95.26	-64.78	-13	-51.78
3	203.97	31.45	-95.26	-63.81	-13	-50.81
4	296.94	35.91	-95.26	-59.35	-13	-46.35
5	406.86	37.93	-95.26	-57.33	-13	-44.33
6	646.04	36.86	-95.26	-58.40	-13	-45.40

Antenna Polarity & Test Distance: Vertical at 3 M

No.	Freq. (MHz)	Reading (dB μ V/m)	Correction Factor (dB)	Emission Value (dBm)	Limit (dBm)	Margin (dB)
1	83.83	29.8	-95.26	-65.46	-13	-52.46
2	154.94	31.76	-95.26	-63.50	-13	-50.50
3	200.44	31.65	-95.26	-63.61	-13	-50.61
4	293.03	37.27	-95.26	-57.99	-13	-44.99
5	405.26	34.27	-95.26	-60.99	-13	-47.99
6	658.6	35.54	-95.26	-59.72	-13	-46.72

Remarks:

1. Follow ANSI 63.26 section 5.2.7 d), Emission Value (dBm) = E (dB μ V/m) - Correction Factor @ 3m.
2. Correction Factor (dB) = 20log(D) - 104.8; where D is the measurement distance @3m.

LTE Band 2: 5 MHz

Mode	TX channel 18625	Frequency Range	Below 1000 MHz
------	------------------	-----------------	----------------

Antenna Polarity & Test Distance: Horizontal at 3 M

No.	Freq. (MHz)	Reading (dB μ V/m)	Correction Factor (dB)	Emission Value (dBm)	Limit (dBm)	Margin (dB)
1	73.66	28.76	-95.26	-66.50	-13	-53.50
2	149.55	29.97	-95.26	-65.29	-13	-52.29
3	204.31	30.78	-95.26	-64.48	-13	-51.48
4	296.64	36.1	-95.26	-59.16	-13	-46.16
5	406.51	37.81	-95.26	-57.45	-13	-44.45
6	646.15	36.7	-95.26	-58.56	-13	-45.56

Antenna Polarity & Test Distance: Vertical at 3 M

No.	Freq. (MHz)	Reading (dB μ V/m)	Correction Factor (dB)	Emission Value (dBm)	Limit (dBm)	Margin (dB)
1	84.25	30.02	-95.26	-65.24	-13	-52.24
2	154.22	31.69	-95.26	-63.57	-13	-50.57
3	199.76	31.42	-95.26	-63.84	-13	-50.84
4	293.65	37.01	-95.26	-58.25	-13	-45.25
5	405.75	34.18	-95.26	-61.08	-13	-48.08
6	658.65	35.28	-95.26	-59.98	-13	-46.98

Remarks:

1. Follow ANSI 63.26 section 5.2.7 d), Emission Value (dBm) = E (dB μ V/m) - Correction Factor @ 3m.
2. Correction Factor (dB) = 20log(D) – 104.8; where D is the measurement distance @3m.

Mode	TX channel 18900	Frequency Range	Below 1000 MHz
------	------------------	-----------------	----------------

Antenna Polarity & Test Distance: Horizontal at 3 M

No.	Freq. (MHz)	Reading (dB μ V/m)	Correction Factor (dB)	Emission Value (dBm)	Limit (dBm)	Margin (dB)
1	73.43	28.84	-95.26	-66.42	-13	-53.42
2	149.83	30.43	-95.26	-64.83	-13	-51.83
3	203.95	30.82	-95.26	-64.44	-13	-51.44
4	296.26	36.48	-95.26	-58.78	-13	-45.78
5	406.36	37.66	-95.26	-57.60	-13	-44.60
6	645.97	37.08	-95.26	-58.18	-13	-45.18

Antenna Polarity & Test Distance: Vertical at 3 M

No.	Freq. (MHz)	Reading (dB μ V/m)	Correction Factor (dB)	Emission Value (dBm)	Limit (dBm)	Margin (dB)
1	84.41	29.84	-95.26	-65.42	-13	-52.42
2	154.23	31.95	-95.26	-63.31	-13	-50.31
3	200.19	31.72	-95.26	-63.54	-13	-50.54
4	293.63	36.89	-95.26	-58.37	-13	-45.37
5	406.02	34.1	-95.26	-61.16	-13	-48.16
6	658.34	34.99	-95.26	-60.27	-13	-47.27

Remarks:

1. Follow ANSI 63.26 section 5.2.7 d), Emission Value (dBm) = E (dB μ V/m) - Correction Factor @ 3m.
2. Correction Factor (dB) = 20log(D) - 104.8; where D is the measurement distance @3m.

Mode	TX channel 19175	Frequency Range	Below 1000 MHz
------	------------------	-----------------	----------------

Antenna Polarity & Test Distance: Horizontal at 3 M

No.	Freq. (MHz)	Reading (dB μ V/m)	Correction Factor (dB)	Emission Value (dBm)	Limit (dBm)	Margin (dB)
1	73.72	28.24	-95.26	-67.02	-13	-54.02
2	149.98	30.34	-95.26	-64.92	-13	-51.92
3	204.05	30.84	-95.26	-64.42	-13	-51.42
4	296.9	36	-95.26	-59.26	-13	-46.26
5	406.46	38.07	-95.26	-57.19	-13	-44.19
6	646.02	37.06	-95.26	-58.20	-13	-45.20

Antenna Polarity & Test Distance: Vertical at 3 M

No.	Freq. (MHz)	Reading (dB μ V/m)	Correction Factor (dB)	Emission Value (dBm)	Limit (dBm)	Margin (dB)
1	83.86	29.77	-95.26	-65.49	-13	-52.49
2	154.72	31.92	-95.26	-63.34	-13	-50.34
3	200.31	31.48	-95.26	-63.78	-13	-50.78
4	293.28	37.5	-95.26	-57.76	-13	-44.76
5	405.35	34.84	-95.26	-60.42	-13	-47.42
6	658.41	35.01	-95.26	-60.25	-13	-47.25

Remarks:

1. Follow ANSI 63.26 section 5.2.7 d), Emission Value (dBm) = E (dB μ V/m) - Correction Factor @ 3m.
2. Correction Factor (dB) = 20log(D) - 104.8; where D is the measurement distance @3m.

LTE Band 2: 10 MHz

Mode	TX channel 18650	Frequency Range	Below 1000 MHz
------	------------------	-----------------	----------------

Antenna Polarity & Test Distance: Horizontal at 3 M

No.	Freq. (MHz)	Reading (dB μ V/m)	Correction Factor (dB)	Emission Value (dBm)	Limit (dBm)	Margin (dB)
1	73.74	28.18	-95.26	-67.08	-13	-54.08
2	150.09	30.48	-95.26	-64.78	-13	-51.78
3	204.25	30.84	-95.26	-64.42	-13	-51.42
4	297.12	36.23	-95.26	-59.03	-13	-46.03
5	407.1	38.03	-95.26	-57.23	-13	-44.23
6	646.27	37.08	-95.26	-58.18	-13	-45.18

Antenna Polarity & Test Distance: Vertical at 3 M

No.	Freq. (MHz)	Reading (dB μ V/m)	Correction Factor (dB)	Emission Value (dBm)	Limit (dBm)	Margin (dB)
1	84.32	29.51	-95.26	-65.75	-13	-52.75
2	154.85	31.83	-95.26	-63.43	-13	-50.43
3	200.71	31.77	-95.26	-63.49	-13	-50.49
4	293.63	37.73	-95.26	-57.53	-13	-44.53
5	405.17	34.6	-95.26	-60.66	-13	-47.66
6	657.86	35.22	-95.26	-60.04	-13	-47.04

Remarks:

1. Follow ANSI 63.26 section 5.2.7 d), Emission Value (dBm) = E (dB μ V/m) - Correction Factor @ 3m.
2. Correction Factor (dB) = 20log(D) – 104.8; where D is the measurement distance @3m.

Mode	TX channel 18900	Frequency Range	Below 1000 MHz
------	------------------	-----------------	----------------

Antenna Polarity & Test Distance: Horizontal at 3 M

No.	Freq. (MHz)	Reading (dB μ V/m)	Correction Factor (dB)	Emission Value (dBm)	Limit (dBm)	Margin (dB)
1	73.79	28.53	-95.26	-66.73	-13	-53.73
2	150.06	30.32	-95.26	-64.94	-13	-51.94
3	203.88	30.68	-95.26	-64.58	-13	-51.58
4	297.19	35.82	-95.26	-59.44	-13	-46.44
5	406.59	37.36	-95.26	-57.90	-13	-44.90
6	646.41	36.45	-95.26	-58.81	-13	-45.81

Antenna Polarity & Test Distance: Vertical at 3 M

No.	Freq. (MHz)	Reading (dB μ V/m)	Correction Factor (dB)	Emission Value (dBm)	Limit (dBm)	Margin (dB)
1	84.4	30.25	-95.26	-65.01	-13	-52.01
2	154.9	31.98	-95.26	-63.28	-13	-50.28
3	200.42	31.74	-95.26	-63.52	-13	-50.52
4	293.35	36.97	-95.26	-58.29	-13	-45.29
5	405.67	34.34	-95.26	-60.92	-13	-47.92
6	658.04	35.3	-95.26	-59.96	-13	-46.96

Remarks:

1. Follow ANSI 63.26 section 5.2.7 d), Emission Value (dBm) = E (dB μ V/m) - Correction Factor @ 3m.
2. Correction Factor (dB) = 20log(D) - 104.8; where D is the measurement distance @3m.

Mode	TX channel 19150	Frequency Range	Below 1000 MHz
------	------------------	-----------------	----------------

Antenna Polarity & Test Distance: Horizontal at 3 M

No.	Freq. (MHz)	Reading (dB μ V/m)	Correction Factor (dB)	Emission Value (dBm)	Limit (dBm)	Margin (dB)
1	73.23	28.13	-95.26	-67.13	-13	-54.13
2	149.8	29.79	-95.26	-65.47	-13	-52.47
3	204.47	31.11	-95.26	-64.15	-13	-51.15
4	296.74	36.22	-95.26	-59.04	-13	-46.04
5	407.12	37.55	-95.26	-57.71	-13	-44.71
6	646.4	36.48	-95.26	-58.78	-13	-45.78

Antenna Polarity & Test Distance: Vertical at 3 M

No.	Freq. (MHz)	Reading (dB μ V/m)	Correction Factor (dB)	Emission Value (dBm)	Limit (dBm)	Margin (dB)
1	84.15	29.93	-95.26	-65.33	-13	-52.33
2	155.09	31.48	-95.26	-63.78	-13	-50.78
3	199.99	31.76	-95.26	-63.50	-13	-50.50
4	292.84	37.57	-95.26	-57.69	-13	-44.69
5	405.81	34.5	-95.26	-60.76	-13	-47.76
6	658.31	34.81	-95.26	-60.45	-13	-47.45

Remarks:

1. Follow ANSI 63.26 section 5.2.7 d), Emission Value (dBm) = E (dB μ V/m) - Correction Factor @ 3m.
2. Correction Factor (dB) = 20log(D) - 104.8; where D is the measurement distance @3m.

LTE Band 2: 15 MHz

Mode	TX channel 18675	Frequency Range	Below 1000 MHz
------	------------------	-----------------	----------------

Antenna Polarity & Test Distance: Horizontal at 3 M

No.	Freq. (MHz)	Reading (dB μ V/m)	Correction Factor (dB)	Emission Value (dBm)	Limit (dBm)	Margin (dB)
1	73.18	28.66	-95.26	-66.60	-13	-53.60
2	150.01	29.76	-95.26	-65.50	-13	-52.50
3	204.67	31.45	-95.26	-63.81	-13	-50.81
4	296.98	35.74	-95.26	-59.52	-13	-46.52
5	407.11	37.59	-95.26	-57.67	-13	-44.67
6	645.88	37.17	-95.26	-58.09	-13	-45.09

Antenna Polarity & Test Distance: Vertical at 3 M

No.	Freq. (MHz)	Reading (dB μ V/m)	Correction Factor (dB)	Emission Value (dBm)	Limit (dBm)	Margin (dB)
1	84.44	29.94	-95.26	-65.32	-13	-52.32
2	154.98	31.2	-95.26	-64.06	-13	-51.06
3	200.48	31.39	-95.26	-63.87	-13	-50.87
4	293.46	37.17	-95.26	-58.09	-13	-45.09
5	405.25	34.32	-95.26	-60.94	-13	-47.94
6	658.62	35.18	-95.26	-60.08	-13	-47.08

Remarks:

1. Follow ANSI 63.26 section 5.2.7 d), Emission Value (dBm) = E (dB μ V/m) - Correction Factor @ 3m.
2. Correction Factor (dB) = 20log(D) – 104.8; where D is the measurement distance @3m.

Mode	TX channel 18900	Frequency Range	Below 1000 MHz
------	------------------	-----------------	----------------

Antenna Polarity & Test Distance: Horizontal at 3 M

No.	Freq. (MHz)	Reading (dB μ V/m)	Correction Factor (dB)	Emission Value (dBm)	Limit (dBm)	Margin (dB)
1	74.02	28.36	-95.26	-66.90	-13	-53.90
2	149.23	29.77	-95.26	-65.49	-13	-52.49
3	204.52	31.5	-95.26	-63.76	-13	-50.76
4	296.31	36.11	-95.26	-59.15	-13	-46.15
5	406.85	37.81	-95.26	-57.45	-13	-44.45
6	646.6	37.16	-95.26	-58.10	-13	-45.10

Antenna Polarity & Test Distance: Vertical at 3 M

No.	Freq. (MHz)	Reading (dB μ V/m)	Correction Factor (dB)	Emission Value (dBm)	Limit (dBm)	Margin (dB)
1	84.39	29.84	-95.26	-65.42	-13	-52.42
2	154.85	31.63	-95.26	-63.63	-13	-50.63
3	200.35	31.95	-95.26	-63.31	-13	-50.31
4	293.48	37.74	-95.26	-57.52	-13	-44.52
5	405.61	34.35	-95.26	-60.91	-13	-47.91
6	658.42	35.73	-95.26	-59.53	-13	-46.53

Remarks:

1. Follow ANSI 63.26 section 5.2.7 d), Emission Value (dBm) = E (dB μ V/m) - Correction Factor @ 3m.
2. Correction Factor (dB) = 20log(D) - 104.8; where D is the measurement distance @3m.

Mode	TX channel 19125	Frequency Range	Below 1000 MHz
------	------------------	-----------------	----------------

Antenna Polarity & Test Distance: Horizontal at 3 M

No.	Freq. (MHz)	Reading (dB μ V/m)	Correction Factor (dB)	Emission Value (dBm)	Limit (dBm)	Margin (dB)
1	73.54	28.62	-95.26	-66.64	-13	-53.64
2	149.9	30.61	-95.26	-64.65	-13	-51.65
3	204.6	30.8	-95.26	-64.46	-13	-51.46
4	296.68	35.73	-95.26	-59.53	-13	-46.53
5	406.81	37.37	-95.26	-57.89	-13	-44.89
6	646.25	37.06	-95.26	-58.20	-13	-45.20

Antenna Polarity & Test Distance: Vertical at 3 M

No.	Freq. (MHz)	Reading (dB μ V/m)	Correction Factor (dB)	Emission Value (dBm)	Limit (dBm)	Margin (dB)
1	83.55	29.93	-95.26	-65.33	-13	-52.33
2	155.01	31.79	-95.26	-63.47	-13	-50.47
3	199.88	31.99	-95.26	-63.27	-13	-50.27
4	293.65	37.69	-95.26	-57.57	-13	-44.57
5	405.89	33.97	-95.26	-61.29	-13	-48.29
6	657.79	35.64	-95.26	-59.62	-13	-46.62

Remarks:

1. Follow ANSI 63.26 section 5.2.7 d), Emission Value (dBm) = E (dB μ V/m) - Correction Factor @ 3m.
2. Correction Factor (dB) = 20log(D) - 104.8; where D is the measurement distance @3m.

LTE Band 2: 20 MHz

Mode	TX channel 18700	Frequency Range	Below 1000 MHz
------	------------------	-----------------	----------------

Antenna Polarity & Test Distance: Horizontal at 3 M

No.	Freq. (MHz)	Reading (dB μ V/m)	Correction Factor (dB)	Emission Value (dBm)	Limit (dBm)	Margin (dB)
1	74.1	28.56	-95.26	-66.70	-13	-53.70
2	149.59	29.79	-95.26	-65.47	-13	-52.47
3	204.09	31.05	-95.26	-64.21	-13	-51.21
4	296.51	36.4	-95.26	-58.86	-13	-45.86
5	406.97	38.11	-95.26	-57.15	-13	-44.15
6	645.92	37.3	-95.26	-57.96	-13	-44.96

Antenna Polarity & Test Distance: Vertical at 3 M

No.	Freq. (MHz)	Reading (dB μ V/m)	Correction Factor (dB)	Emission Value (dBm)	Limit (dBm)	Margin (dB)
1	84.04	30.09	-95.26	-65.17	-13	-52.17
2	154.45	31.87	-95.26	-63.39	-13	-50.39
3	200.07	32.23	-95.26	-63.03	-13	-50.03
4	293.26	37	-95.26	-58.26	-13	-45.26
5	405.84	34.66	-95.26	-60.60	-13	-47.60
6	658.6	34.8	-95.26	-60.46	-13	-47.46

Remarks:

1. Follow ANSI 63.26 section 5.2.7 d), Emission Value (dBm) = E (dB μ V/m) - Correction Factor @ 3m.
2. Correction Factor (dB) = 20log(D) – 104.8; where D is the measurement distance @3m.

Mode	TX channel 18900	Frequency Range	Below 1000 MHz
------	------------------	-----------------	----------------

Antenna Polarity & Test Distance: Horizontal at 3 M

No.	Freq. (MHz)	Reading (dB μ V/m)	Correction Factor (dB)	Emission Value (dBm)	Limit (dBm)	Margin (dB)
1	73.99	29	-95.26	-66.26	-13	-53.26
2	149.37	29.83	-95.26	-65.43	-13	-52.43
3	204.68	30.99	-95.26	-64.27	-13	-51.27
4	296.23	35.94	-95.26	-59.32	-13	-46.32
5	406.38	37.53	-95.26	-57.73	-13	-44.73
6	645.8	36.39	-95.26	-58.87	-13	-45.87

Antenna Polarity & Test Distance: Vertical at 3 M

No.	Freq. (MHz)	Reading (dB μ V/m)	Correction Factor (dB)	Emission Value (dBm)	Limit (dBm)	Margin (dB)
1	83.89	29.76	-95.26	-65.50	-13	-52.50
2	154.86	31.83	-95.26	-63.43	-13	-50.43
3	199.78	31.69	-95.26	-63.57	-13	-50.57
4	293.37	37.26	-95.26	-58.00	-13	-45.00
5	405.66	34.65	-95.26	-60.61	-13	-47.61
6	657.87	35.43	-95.26	-59.83	-13	-46.83

Remarks:

1. Follow ANSI 63.26 section 5.2.7 d), Emission Value (dBm) = E (dB μ V/m) - Correction Factor @ 3m.
2. Correction Factor (dB) = 20log(D) - 104.8; where D is the measurement distance @3m.

Mode	TX channel 19100	Frequency Range	Below 1000 MHz
------	------------------	-----------------	----------------

Antenna Polarity & Test Distance: Horizontal at 3 M

No.	Freq. (MHz)	Reading (dB μ V/m)	Correction Factor (dB)	Emission Value (dBm)	Limit (dBm)	Margin (dB)
1	73.34	28.51	-95.26	-66.75	-13	-53.75
2	149.55	30.49	-95.26	-64.77	-13	-51.77
3	203.92	31.01	-95.26	-64.25	-13	-51.25
4	296.74	36.02	-95.26	-59.24	-13	-46.24
5	406.91	37.26	-95.26	-58.00	-13	-45.00
6	646.4	36.93	-95.26	-58.33	-13	-45.33

Antenna Polarity & Test Distance: Vertical at 3 M

No.	Freq. (MHz)	Reading (dB μ V/m)	Correction Factor (dB)	Emission Value (dBm)	Limit (dBm)	Margin (dB)
1	83.62	29.59	-95.26	-65.67	-13	-52.67
2	154.89	31.42	-95.26	-63.84	-13	-50.84
3	200.59	31.74	-95.26	-63.52	-13	-50.52
4	293.7	37.21	-95.26	-58.05	-13	-45.05
5	405.66	34.3	-95.26	-60.96	-13	-47.96
6	657.97	34.87	-95.26	-60.39	-13	-47.39

Remarks:

1. Follow ANSI 63.26 section 5.2.7 d), Emission Value (dBm) = E (dB μ V/m) - Correction Factor @ 3m.
2. Correction Factor (dB) = 20log(D) - 104.8; where D is the measurement distance @3m.

Above 1GHz
WCDMA B2:

Mode	TX channel 9262	Frequency Range	Above 1000 MHz
------	-----------------	-----------------	----------------

Antenna Polarity & Test Distance: Horizontal at 3 M

No.	Freq. (MHz)	Reading (dB μ V/m)	Correction Factor (dB)	Emission Value (dBm)	Limit (dBm)	Margin (dB)
1	3704.8	46.62	-95.26	-48.64	-13	-35.64
2	5557.2	44.01	-95.26	-51.25	-13	-38.25
3	7409.6	47.49	-95.26	-47.77	-13	-34.77
4	9262	49.8	-95.26	-45.46	-13	-32.46

Antenna Polarity & Test Distance: Vertical at 3 M

No.	Freq. (MHz)	Reading (dB μ V/m)	Correction Factor (dB)	Emission Value (dBm)	Limit (dBm)	Margin (dB)
1	3704.8	54.22	-95.26	-41.04	-13	-28.04
2	5557.2	45.04	-95.26	-50.22	-13	-37.22
3	7409.6	47.63	-95.26	-47.63	-13	-34.63
4	9262	51.27	-95.26	-43.99	-13	-30.99

Remarks:

1. Follow ANSI 63.26 section 5.2.7 d), Emission Value (dBm) = E (dB μ V/m) - Correction Factor @ 3m.
2. Correction Factor (dB) = 20log(D) - 104.8; where D is the measurement distance @3m.

Mode	TX channel 9400	Frequency Range	Above 1000 MHz
------	-----------------	-----------------	----------------

Antenna Polarity & Test Distance: Horizontal at 3 M

No.	Freq. (MHz)	Reading (dB μ V/m)	Correction Factor (dB)	Emission Value (dBm)	Limit (dBm)	Margin (dB)
1	3776	46.28	-95.26	-48.98	-13	-35.98
2	5664	43.79	-95.26	-51.47	-13	-38.47
3	7552	48.3	-95.26	-46.96	-13	-33.96
4	9440	49.79	-95.26	-45.47	-13	-32.47

Antenna Polarity & Test Distance: Vertical at 3 M

No.	Freq. (MHz)	Reading (dB μ V/m)	Correction Factor (dB)	Emission Value (dBm)	Limit (dBm)	Margin (dB)
1	3776	53.8	-95.26	-41.46	-13	-28.46
2	5664	45.09	-95.26	-50.17	-13	-37.17
3	7552	47.64	-95.26	-47.62	-13	-34.62
4	9440	50.83	-95.26	-44.43	-13	-31.43

Remarks:

1. Follow ANSI 63.26 section 5.2.7 d), Emission Value (dBm) = E (dB μ V/m) - Correction Factor @ 3m.
2. Correction Factor (dB) = 20log(D) - 104.8; where D is the measurement distance @3m.

Mode	TX channel 9538	Frequency Range	Above 1000 MHz
------	-----------------	-----------------	----------------

Antenna Polarity & Test Distance: Horizontal at 3 M

No.	Freq. (MHz)	Reading (dB μ V/m)	Correction Factor (dB)	Emission Value (dBm)	Limit (dBm)	Margin (dB)
1	3815.2	46.11	-95.26	-49.15	-13	-36.15
2	5722.8	43.9	-95.26	-51.36	-13	-38.36
3	7630.4	48.12	-95.26	-47.14	-13	-34.14
4	9538	49.8	-95.26	-45.46	-13	-32.46

Antenna Polarity & Test Distance: Vertical at 3 M

No.	Freq. (MHz)	Reading (dB μ V/m)	Correction Factor (dB)	Emission Value (dBm)	Limit (dBm)	Margin (dB)
1	3815.2	54.1	-95.26	-41.16	-13	-28.16
2	5722.8	45.28	-95.26	-49.98	-13	-36.98
3	7630.4	47.47	-95.26	-47.79	-13	-34.79
4	9538	51.01	-95.26	-44.25	-13	-31.25

Remarks:

1. Follow ANSI 63.26 section 5.2.7 d), Emission Value (dBm) = E (dB μ V/m) - Correction Factor @ 3m.
2. Correction Factor (dB) = 20log(D) - 104.8; where D is the measurement distance @3m.

LTE Band 2: 1.4 MHz

Mode	TX channel 18607	Frequency Range	Above 1000 MHz
------	------------------	-----------------	----------------

Antenna Polarity & Test Distance: Horizontal at 3 M

No.	Freq. (MHz)	Reading (dB μ V/m)	Correction Factor (dB)	Emission Value (dBm)	Limit (dBm)	Margin (dB)
1	3701.4	46.47	-95.26	-48.79	-13	-35.79
2	5552.1	44.29	-95.26	-50.97	-13	-37.97
3	7402.8	47.86	-95.26	-47.40	-13	-34.40
4	9253.5	50.29	-95.26	-44.97	-13	-31.97

Antenna Polarity & Test Distance: Vertical at 3 M

No.	Freq. (MHz)	Reading (dB μ V/m)	Correction Factor (dB)	Emission Value (dBm)	Limit (dBm)	Margin (dB)
1	3701.4	53.73	-95.26	-41.53	-13	-28.53
2	5552.1	44.96	-95.26	-50.30	-13	-37.30
3	7402.8	47.74	-95.26	-47.52	-13	-34.52
4	9253.5	50.92	-95.26	-44.34	-13	-31.34

Remarks:

1. Follow ANSI 63.26 section 5.2.7 d), Emission Value (dBm) = E (dB μ V/m) - Correction Factor @ 3m.
2. Correction Factor (dB) = $20\log(D) - 104.8$; where D is the measurement distance @3m.

Mode	TX channel 18900	Frequency Range	Above 1000 MHz
------	------------------	-----------------	----------------

Antenna Polarity & Test Distance: Horizontal at 3 M

No.	Freq. (MHz)	Reading (dB μ V/m)	Correction Factor (dB)	Emission Value (dBm)	Limit (dBm)	Margin (dB)
1	3760	46.71	-95.26	-48.55	-13	-35.55
2	5640	44.72	-95.26	-50.54	-13	-37.54
3	7520	48.05	-95.26	-47.21	-13	-34.21
4	9400	50.14	-95.26	-45.12	-13	-32.12

Antenna Polarity & Test Distance: Vertical at 3 M

No.	Freq. (MHz)	Reading (dB μ V/m)	Correction Factor (dB)	Emission Value (dBm)	Limit (dBm)	Margin (dB)
1	3760	53.81	-95.26	-41.45	-13	-28.45
2	5640	44.65	-95.26	-50.61	-13	-37.61
3	7520	48.06	-95.26	-47.20	-13	-34.20
4	9400	51.06	-95.26	-44.20	-13	-31.20

Remarks:

1. Follow ANSI 63.26 section 5.2.7 d), Emission Value (dBm) = E (dB μ V/m) - Correction Factor @ 3m.
2. Correction Factor (dB) = 20log(D) - 104.8; where D is the measurement distance @3m.

Mode	TX channel 19193	Frequency Range	Above 1000 MHz
------	------------------	-----------------	----------------

Antenna Polarity & Test Distance: Horizontal at 3 M

No.	Freq. (MHz)	Reading (dB μ V/m)	Correction Factor (dB)	Emission Value (dBm)	Limit (dBm)	Margin (dB)
1	3818.6	46.81	-95.26	-48.45	-13	-35.45
2	5727.9	44.46	-95.26	-50.80	-13	-37.80
3	7637.2	48.23	-95.26	-47.03	-13	-34.03
4	9546.5	49.81	-95.26	-45.45	-13	-32.45

Antenna Polarity & Test Distance: Vertical at 3 M

No.	Freq. (MHz)	Reading (dB μ V/m)	Correction Factor (dB)	Emission Value (dBm)	Limit (dBm)	Margin (dB)
1	3818.6	53.43	-95.26	-41.83	-13	-28.83
2	5727.9	44.67	-95.26	-50.59	-13	-37.59
3	7637.2	47.8	-95.26	-47.46	-13	-34.46
4	9546.5	51.37	-95.26	-43.89	-13	-30.89

Remarks:

1. Follow ANSI 63.26 section 5.2.7 d), Emission Value (dBm) = E (dB μ V/m) - Correction Factor @ 3m.
2. Correction Factor (dB) = 20log(D) - 104.8; where D is the measurement distance @3m.

LTE Band 2: 3 MHz

Mode	TX channel 18615	Frequency Range	Above 1000 MHz
------	------------------	-----------------	----------------

Antenna Polarity & Test Distance: Horizontal at 3 M

No.	Freq. (MHz)	Reading (dB μ V/m)	Correction Factor (dB)	Emission Value (dBm)	Limit (dBm)	Margin (dB)
1	3703	46.66	-95.26	-48.60	-13	-35.60
2	5554.5	43.86	-95.26	-51.40	-13	-38.40
3	7406	47.71	-95.26	-47.55	-13	-34.55
4	9257.5	50.72	-95.26	-44.54	-13	-31.54

Antenna Polarity & Test Distance: Vertical at 3 M

No.	Freq. (MHz)	Reading (dB μ V/m)	Correction Factor (dB)	Emission Value (dBm)	Limit (dBm)	Margin (dB)
1	3703	53.63	-95.26	-41.63	-13	-28.63
2	5554.5	44.57	-95.26	-50.69	-13	-37.69
3	7406	47.53	-95.26	-47.73	-13	-34.73
4	9257.5	51.35	-95.26	-43.91	-13	-30.91

Remarks:

1. Follow ANSI 63.26 section 5.2.7 d), Emission Value (dBm) = E (dB μ V/m) - Correction Factor @ 3m.
2. Correction Factor (dB) = 20log(D) – 104.8; where D is the measurement distance @3m.

Mode	TX channel 18900	Frequency Range	Above 1000 MHz
------	------------------	-----------------	----------------

Antenna Polarity & Test Distance: Horizontal at 3 M

No.	Freq. (MHz)	Reading (dB μ V/m)	Correction Factor (dB)	Emission Value (dBm)	Limit (dBm)	Margin (dB)
1	3760	46.81	-95.26	-48.45	-13	-35.45
2	5640	44.76	-95.26	-50.50	-13	-37.50
3	7520	48.13	-95.26	-47.13	-13	-34.13
4	9400	50.03	-95.26	-45.23	-13	-32.23

Antenna Polarity & Test Distance: Vertical at 3 M

No.	Freq. (MHz)	Reading (dB μ V/m)	Correction Factor (dB)	Emission Value (dBm)	Limit (dBm)	Margin (dB)
1	3760	54.11	-95.26	-41.15	-13	-28.15
2	5640	45.2	-95.26	-50.06	-13	-37.06
3	7520	47.68	-95.26	-47.58	-13	-34.58
4	9400	50.7	-95.26	-44.56	-13	-31.56

Remarks:

1. Follow ANSI 63.26 section 5.2.7 d), Emission Value (dBm) = E (dB μ V/m) - Correction Factor @ 3m.
2. Correction Factor (dB) = 20log(D) - 104.8; where D is the measurement distance @3m.

Mode	TX channel 19185	Frequency Range	Above 1000 MHz
------	------------------	-----------------	----------------

Antenna Polarity & Test Distance: Horizontal at 3 M

No.	Freq. (MHz)	Reading (dB μ V/m)	Correction Factor (dB)	Emission Value (dBm)	Limit (dBm)	Margin (dB)
1	3817	46.6	-95.26	-48.66	-13	-35.66
2	5725.5	44.12	-95.26	-51.14	-13	-38.14
3	7634	48.08	-95.26	-47.18	-13	-34.18
4	9542.5	50.17	-95.26	-45.09	-13	-32.09

Antenna Polarity & Test Distance: Vertical at 3 M

No.	Freq. (MHz)	Reading (dB μ V/m)	Correction Factor (dB)	Emission Value (dBm)	Limit (dBm)	Margin (dB)
1	3817	53.81	-95.26	-41.45	-13	-28.45
2	5725.5	44.62	-95.26	-50.64	-13	-37.64
3	7634	47.79	-95.26	-47.47	-13	-34.47
4	9542.5	50.7	-95.26	-44.56	-13	-31.56

Remarks:

1. Follow ANSI 63.26 section 5.2.7 d), Emission Value (dBm) = E (dB μ V/m) - Correction Factor @ 3m.
2. Correction Factor (dB) = 20log(D) - 104.8; where D is the measurement distance @3m.

LTE Band 2: 5 MHz

Mode	TX channel 18625	Frequency Range	Above 1000 MHz
------	------------------	-----------------	----------------

Antenna Polarity & Test Distance: Horizontal at 3 M

No.	Freq. (MHz)	Reading (dB μ V/m)	Correction Factor (dB)	Emission Value (dBm)	Limit (dBm)	Margin (dB)
1	3705	46.03	-95.26	-49.23	-13	-36.23
2	5557.5	43.86	-95.26	-51.40	-13	-38.40
3	7410	48.11	-95.26	-47.15	-13	-34.15
4	9262.5	50.51	-95.26	-44.75	-13	-31.75

Antenna Polarity & Test Distance: Vertical at 3 M

No.	Freq. (MHz)	Reading (dB μ V/m)	Correction Factor (dB)	Emission Value (dBm)	Limit (dBm)	Margin (dB)
1	3705	54.06	-95.26	-41.20	-13	-28.20
2	5557.5	44.88	-95.26	-50.38	-13	-37.38
3	7410	47.63	-95.26	-47.63	-13	-34.63
4	9262.5	50.99	-95.26	-44.27	-13	-31.27

Remarks:

1. Follow ANSI 63.26 section 5.2.7 d), Emission Value (dBm) = E (dB μ V/m) - Correction Factor @ 3m.
2. Correction Factor (dB) = 20log(D) - 104.8; where D is the measurement distance @3m.

Mode	TX channel 18900	Frequency Range	Above 1000 MHz
------	------------------	-----------------	----------------

Antenna Polarity & Test Distance: Horizontal at 3 M

No.	Freq. (MHz)	Reading (dB μ V/m)	Correction Factor (dB)	Emission Value (dBm)	Limit (dBm)	Margin (dB)
1	3760	46.64	-95.26	-48.62	-13	-35.62
2	5640	44.77	-95.26	-50.49	-13	-37.49
3	7520	48.33	-95.26	-46.93	-13	-33.93
4	9400	50.66	-95.26	-44.60	-13	-31.60

Antenna Polarity & Test Distance: Vertical at 3 M

No.	Freq. (MHz)	Reading (dB μ V/m)	Correction Factor (dB)	Emission Value (dBm)	Limit (dBm)	Margin (dB)
1	3760	54.17	-95.26	-41.09	-13	-28.09
2	5640	44.94	-95.26	-50.32	-13	-37.32
3	7520	47.29	-95.26	-47.97	-13	-34.97
4	9400	50.93	-95.26	-44.33	-13	-31.33

Remarks:

1. Follow ANSI 63.26 section 5.2.7 d), Emission Value (dBm) = E (dB μ V/m) - Correction Factor @ 3m.
2. Correction Factor (dB) = 20log(D) - 104.8; where D is the measurement distance @3m.

Mode	TX channel 19175	Frequency Range	Above 1000 MHz
------	------------------	-----------------	----------------

Antenna Polarity & Test Distance: Horizontal at 3 M

No.	Freq. (MHz)	Reading (dB μ V/m)	Correction Factor (dB)	Emission Value (dBm)	Limit (dBm)	Margin (dB)
1	3815	46.94	-95.26	-48.32	-13	-35.32
2	5722.5	44.13	-95.26	-51.13	-13	-38.13
3	7630	47.39	-95.26	-47.87	-13	-34.87
4	9537.5	50.49	-95.26	-44.77	-13	-31.77

Antenna Polarity & Test Distance: Vertical at 3 M

No.	Freq. (MHz)	Reading (dB μ V/m)	Correction Factor (dB)	Emission Value (dBm)	Limit (dBm)	Margin (dB)
1	3815	53.56	-95.26	-41.70	-13	-28.70
2	5722.5	45.18	-95.26	-50.08	-13	-37.08
3	7630	47.31	-95.26	-47.95	-13	-34.95
4	9537.5	51.4	-95.26	-43.86	-13	-30.86

Remarks:

1. Follow ANSI 63.26 section 5.2.7 d), Emission Value (dBm) = E (dB μ V/m) - Correction Factor @ 3m.
2. Correction Factor (dB) = 20log(D) - 104.8; where D is the measurement distance @3m.

LTE Band 2: 10 MHz

Mode	TX channel 18650	Frequency Range	Above 1000 MHz
------	------------------	-----------------	----------------

Antenna Polarity & Test Distance: Horizontal at 3 M

No.	Freq. (MHz)	Reading (dB μ V/m)	Correction Factor (dB)	Emission Value (dBm)	Limit (dBm)	Margin (dB)
1	3710	46.84	-95.26	-48.42	-13	-35.42
2	5565	43.79	-95.26	-51.47	-13	-38.47
3	7420	48.1	-95.26	-47.16	-13	-34.16
4	9275	50.05	-95.26	-45.21	-13	-32.21

Antenna Polarity & Test Distance: Vertical at 3 M

No.	Freq. (MHz)	Reading (dB μ V/m)	Correction Factor (dB)	Emission Value (dBm)	Limit (dBm)	Margin (dB)
1	3710	53.4	-95.26	-41.86	-13	-28.86
2	5565	45.4	-95.26	-49.86	-13	-36.86
3	7420	47.65	-95.26	-47.61	-13	-34.61
4	9275	51.25	-95.26	-44.01	-13	-31.01

Remarks:

1. Follow ANSI 63.26 section 5.2.7 d), Emission Value (dBm) = E (dB μ V/m) - Correction Factor @ 3m.
2. Correction Factor (dB) = $20\log(D) - 104.8$; where D is the measurement distance @3m.

Mode	TX channel 18900	Frequency Range	Above 1000 MHz
------	------------------	-----------------	----------------

Antenna Polarity & Test Distance: Horizontal at 3 M

No.	Freq. (MHz)	Reading (dB μ V/m)	Correction Factor (dB)	Emission Value (dBm)	Limit (dBm)	Margin (dB)
1	3760	46.01	-95.26	-49.25	-13	-36.25
2	5640	44.69	-95.26	-50.57	-13	-37.57
3	7520	47.79	-95.26	-47.47	-13	-34.47
4	9400	49.91	-95.26	-45.35	-13	-32.35

Antenna Polarity & Test Distance: Vertical at 3 M

No.	Freq. (MHz)	Reading (dB μ V/m)	Correction Factor (dB)	Emission Value (dBm)	Limit (dBm)	Margin (dB)
1	3760	54.23	-95.26	-41.03	-13	-28.03
2	5640	45.23	-95.26	-50.03	-13	-37.03
3	7520	47.24	-95.26	-48.02	-13	-35.02
4	9400	50.61	-95.26	-44.65	-13	-31.65

Remarks:

1. Follow ANSI 63.26 section 5.2.7 d), Emission Value (dBm) = E (dB μ V/m) - Correction Factor @ 3m.
2. Correction Factor (dB) = 20log(D) - 104.8; where D is the measurement distance @3m.

Mode	TX channel 19150	Frequency Range	Above 1000 MHz
------	------------------	-----------------	----------------

Antenna Polarity & Test Distance: Horizontal at 3 M

No.	Freq. (MHz)	Reading (dB μ V/m)	Correction Factor (dB)	Emission Value (dBm)	Limit (dBm)	Margin (dB)
1	3810	46.81	-95.26	-48.45	-13	-35.45
2	5715	44.29	-95.26	-50.97	-13	-37.97
3	7620	47.57	-95.26	-47.69	-13	-34.69
4	9525	49.88	-95.26	-45.38	-13	-32.38

Antenna Polarity & Test Distance: Vertical at 3 M

No.	Freq. (MHz)	Reading (dB μ V/m)	Correction Factor (dB)	Emission Value (dBm)	Limit (dBm)	Margin (dB)
1	3810	53.26	-95.26	-42.00	-13	-29.00
2	5715	45.13	-95.26	-50.13	-13	-37.13
3	7620	48.17	-95.26	-47.09	-13	-34.09
4	9525	51.23	-95.26	-44.03	-13	-31.03

Remarks:

1. Follow ANSI 63.26 section 5.2.7 d), Emission Value (dBm) = E (dB μ V/m) - Correction Factor @ 3m.
2. Correction Factor (dB) = 20log(D) - 104.8; where D is the measurement distance @3m.

LTE Band 2: 15 MHz

Mode	TX channel 18675	Frequency Range	Above 1000 MHz
------	------------------	-----------------	----------------

Antenna Polarity & Test Distance: Horizontal at 3 M

No.	Freq. (MHz)	Reading (dB μ V/m)	Correction Factor (dB)	Emission Value (dBm)	Limit (dBm)	Margin (dB)
1	3715	46.52	-95.26	-48.74	-13	-35.74
2	5572.5	43.85	-95.26	-51.41	-13	-38.41
3	7430	47.69	-95.26	-47.57	-13	-34.57
4	9287.5	50.4	-95.26	-44.86	-13	-31.86

Antenna Polarity & Test Distance: Vertical at 3 M

No.	Freq. (MHz)	Reading (dB μ V/m)	Correction Factor (dB)	Emission Value (dBm)	Limit (dBm)	Margin (dB)
1	3715	53.38	-95.26	-41.88	-13	-28.88
2	5572.5	44.92	-95.26	-50.34	-13	-37.34
3	7430	47.26	-95.26	-48.00	-13	-35.00
4	9287.5	50.76	-95.26	-44.50	-13	-31.50

Remarks:

1. Follow ANSI 63.26 section 5.2.7 d), Emission Value (dBm) = E (dB μ V/m) - Correction Factor @ 3m.
2. Correction Factor (dB) = 20log(D) – 104.8; where D is the measurement distance @3m.

Mode	TX channel 18900	Frequency Range	Above 1000 MHz
------	------------------	-----------------	----------------

Antenna Polarity & Test Distance: Horizontal at 3 M

No.	Freq. (MHz)	Reading (dB μ V/m)	Correction Factor (dB)	Emission Value (dBm)	Limit (dBm)	Margin (dB)
1	3760	46.35	-95.26	-48.91	-13	-35.91
2	5640	44.75	-95.26	-50.51	-13	-37.51
3	7520	48.15	-95.26	-47.11	-13	-34.11
4	9400	50.06	-95.26	-45.20	-13	-32.20

Antenna Polarity & Test Distance: Vertical at 3 M

No.	Freq. (MHz)	Reading (dB μ V/m)	Correction Factor (dB)	Emission Value (dBm)	Limit (dBm)	Margin (dB)
1	3760	53.84	-95.26	-41.42	-13	-28.42
2	5640	45.16	-95.26	-50.10	-13	-37.10
3	7520	47.33	-95.26	-47.93	-13	-34.93
4	9400	51.3	-95.26	-43.96	-13	-30.96

Remarks:

1. Follow ANSI 63.26 section 5.2.7 d), Emission Value (dBm) = E (dB μ V/m) - Correction Factor @ 3m.
2. Correction Factor (dB) = 20log(D) - 104.8; where D is the measurement distance @3m.

Mode	TX channel 19125	Frequency Range	Above 1000 MHz
------	------------------	-----------------	----------------

Antenna Polarity & Test Distance: Horizontal at 3 M

No.	Freq. (MHz)	Reading (dB μ V/m)	Correction Factor (dB)	Emission Value (dBm)	Limit (dBm)	Margin (dB)
1	3805	46.25	-95.26	-49.01	-13	-36.01
2	5707.5	44.35	-95.26	-50.91	-13	-37.91
3	7610	47.72	-95.26	-47.54	-13	-34.54
4	9512.5	50.38	-95.26	-44.88	-13	-31.88

Antenna Polarity & Test Distance: Vertical at 3 M

No.	Freq. (MHz)	Reading (dB μ V/m)	Correction Factor (dB)	Emission Value (dBm)	Limit (dBm)	Margin (dB)
1	3805	54.2	-95.26	-41.06	-13	-28.06
2	5707.5	44.9	-95.26	-50.36	-13	-37.36
3	7610	47.48	-95.26	-47.78	-13	-34.78
4	9512.5	50.46	-95.26	-44.80	-13	-31.80

Remarks:

1. Follow ANSI 63.26 section 5.2.7 d), Emission Value (dBm) = E (dB μ V/m) - Correction Factor @ 3m.
2. Correction Factor (dB) = 20log(D) - 104.8; where D is the measurement distance @3m.

LTE Band 2: 20 MHz

Mode	TX channel 18700	Frequency Range	Above 1000 MHz
------	------------------	-----------------	----------------

Antenna Polarity & Test Distance: Horizontal at 3 M

No.	Freq. (MHz)	Reading (dB μ V/m)	Correction Factor (dB)	Emission Value (dBm)	Limit (dBm)	Margin (dB)
1	3720	46.44	-95.26	-48.82	-13	-35.82
2	5580	44.54	-95.26	-50.72	-13	-37.72
3	7440	48.35	-95.26	-46.91	-13	-33.91
4	9300	50.36	-95.26	-44.90	-13	-31.90

Antenna Polarity & Test Distance: Vertical at 3 M

No.	Freq. (MHz)	Reading (dB μ V/m)	Correction Factor (dB)	Emission Value (dBm)	Limit (dBm)	Margin (dB)
1	3720	53.62	-95.26	-41.64	-13	-28.64
2	5580	44.65	-95.26	-50.61	-13	-37.61
3	7440	47.7	-95.26	-47.56	-13	-34.56
4	9300	51.17	-95.26	-44.09	-13	-31.09

Remarks:

1. Follow ANSI 63.26 section 5.2.7 d), Emission Value (dBm) = E (dB μ V/m) - Correction Factor @ 3m.
2. Correction Factor (dB) = 20log(D) – 104.8; where D is the measurement distance @3m.

Mode	TX channel 18900	Frequency Range	Above 1000 MHz
------	------------------	-----------------	----------------

Antenna Polarity & Test Distance: Horizontal at 3 M

No.	Freq. (MHz)	Reading (dB μ V/m)	Correction Factor (dB)	Emission Value (dBm)	Limit (dBm)	Margin (dB)
1	3760	46.71	-95.26	-48.55	-13	-35.55
2	5640	43.93	-95.26	-51.33	-13	-38.33
3	7520	47.81	-95.26	-47.45	-13	-34.45
4	9400	50.41	-95.26	-44.85	-13	-31.85

Antenna Polarity & Test Distance: Vertical at 3 M

No.	Freq. (MHz)	Reading (dB μ V/m)	Correction Factor (dB)	Emission Value (dBm)	Limit (dBm)	Margin (dB)
1	3760	53.74	-95.26	-41.52	-13	-28.52
2	5640	44.64	-95.26	-50.62	-13	-37.62
3	7520	47.45	-95.26	-47.81	-13	-34.81
4	9400	51.14	-95.26	-44.12	-13	-31.12

Remarks:

1. Follow ANSI 63.26 section 5.2.7 d), Emission Value (dBm) = E (dB μ V/m) - Correction Factor @ 3m.
2. Correction Factor (dB) = 20log(D) - 104.8; where D is the measurement distance @3m.

Mode	TX channel 19100	Frequency Range	Above 1000 MHz
------	------------------	-----------------	----------------

Antenna Polarity & Test Distance: Horizontal at 3 M

No.	Freq. (MHz)	Reading (dB μ V/m)	Correction Factor (dB)	Emission Value (dBm)	Limit (dBm)	Margin (dB)
1	3800	45.97	-95.26	-49.29	-13	-36.29
2	5700	44.28	-95.26	-50.98	-13	-37.98
3	7600	48.36	-95.26	-46.90	-13	-33.90
4	9500	50.03	-95.26	-45.23	-13	-32.23

Antenna Polarity & Test Distance: Vertical at 3 M

No.	Freq. (MHz)	Reading (dB μ V/m)	Correction Factor (dB)	Emission Value (dBm)	Limit (dBm)	Margin (dB)
1	3800	53.93	-95.26	-41.33	-13	-28.33
2	5700	45.12	-95.26	-50.14	-13	-37.14
3	7600	47.59	-95.26	-47.67	-13	-34.67
4	9500	50.7	-95.26	-44.56	-13	-31.56

Remarks:

1. Follow ANSI 63.26 section 5.2.7 d), Emission Value (dBm) = E (dB μ V/m) - Correction Factor @ 3m.
2. Correction Factor (dB) = 20log(D) - 104.8; where D is the measurement distance @3m.

5 Pictures of Test Arrangements

Please refer to the attached file (Test Setup Photo).

Appendix – Information of the Testing Laboratories

We, Bureau Veritas Consumer Products Services (H.K.) Ltd., Taoyuan Branch, were founded in 1988 to provide our best service in EMC, Radio, Telecom and Safety consultation. Our laboratories are accredited and approved according to ISO/IEC 17025.

If you have any comments, please feel free to contact us at the following:

Lin Kou EMC/RF Lab

Tel: 886-2-26052180

Fax: 886-2-26051924

Hsin Chu EMC/RF/Telecom Lab

Tel: 886-3-6668565

Fax: 886-3-6668323

Hwa Ya EMC/RF/Safety Lab

Tel: 886-3-3183232

Fax: 886-3-3270892

Email: service.adt@tw.bureauveritas.com

Web Site: www.bureauveritas-adt.com

The address and road map of all our labs can be found in our web site also.

--- END ---