

FCC Test Report (PART 27)

Report No.: RF200518E05-7

FCC ID: MQT-AT150R3

Test Model: xCL_AT-150-R3-18U

Received Date: May 18, 2020

Test Date: June 08 to 29, 2020

Issued Date: Sep. 18, 2020

Applicant: XAC AUTOMATION CORP.

Address: 4F, No. 30, INDUSTRY E. RD. IX, SCIENCE-BASED INDUSTRIAL
PARK,HSINCHU,TAIWAN

Issued By: Bureau Veritas Consumer Products Services (H.K.) Ltd., Taoyuan Branch
Hsin Chu Laboratory

Lab Address: E-2, No.1, Li Hsin 1st Road, Hsinchu Science Park, Hsinchu City 300,
Taiwan

Test Location: E-2, No.1, Li Hsin 1st Road, Hsinchu Science Park, Hsinchu City 300,
Taiwan

**FCC Registration /
Designation Number:** 723255 / TW2022



This report is for your exclusive use. Any copying or replication of this report to or for any other person or entity, or use of our name or trademark, is permitted only with our prior written permission. This report sets forth our findings solely with respect to the test samples identified herein. The results set forth in this report are not indicative or representative of the quality or characteristics of the lot from which a test sample was taken or any similar or identical product unless specifically and expressly noted. Our report includes all of the tests requested by you and the results thereof based upon the information that you provided to us. You have 60 days from date of issuance of this report to notify us of any material error or omission caused by our negligence, provided, however, that such notice shall be in writing and shall specifically address the issue you wish to raise. A failure to raise such issue within the prescribed time shall constitute your unqualified acceptance of the completeness of this report, the tests conducted and the correctness of the report contents. Unless specifically mentioned, the uncertainty of measurement has been explicitly taken into account to declare the compliance or non-compliance to the specification.

Table of Contents

Release Control Record	4
1 Certificate of Conformity	5
2 Summary of Test Results	6
2.1 Measurement Uncertainty	6
2.2 Test Site and Instruments	7
3 General Information	9
3.1 General Description of EUT	9
3.2 Configuration of System under Test	12
3.2.1 Description of Support Units	13
3.3 Test Mode Applicability and Tested Channel Detail	14
3.4 EUT Operating Conditions	18
3.5 General Description of Applied Standards and references	18
4 Test Types and Results	19
4.1 Output Power Measurement	19
4.1.1 Limits of Output Power Measurement	19
4.1.2 Test Procedures	19
4.1.3 Test Setup	20
4.1.4 Test Results	21
4.2 Modulation characteristics Measurement	28
4.2.1 Limits of Modulation characteristics	28
4.2.2 Test Procedure	28
4.2.3 Test Setup	28
4.2.4 Test Results	29
4.3 Frequency Stability Measurement	30
4.3.1 Limits of Frequency Stability Measurement	30
4.3.2 Test Procedure	30
4.3.3 Test Setup	30
4.3.4 Test Results	31
4.4 Emission Bandwidth Measurement	33
4.4.1 Limits of Emission Bandwidth Measurement	33
4.4.2 Test Procedure	33
4.4.3 Test Setup	33
4.4.4 Test Results (-26dB Bandwidth)	34
4.4.5 Test Results (Occupied Bandwidth)	37
4.5 Channel Edge Measurement	40
4.5.1 Limits of Channel Edge Measurement	40
4.5.2 Test Setup	41
4.5.3 Test Procedures	41
4.5.4 Test Results	42
4.6 Peak to Average Ratio	52
4.6.1 Limits of Peak to Average Ratio Measurement	52
4.6.2 Test Setup	52
4.6.3 Test Procedures	52
4.6.4 Test Results	53
4.7 Conducted Spurious Emissions	56
4.7.1 Limits of Conducted Spurious Emissions Measurement	56
4.7.2 Test Setup	56
4.7.3 Test Procedure	56
4.7.4 Test Results	57
4.8 Radiated Emission Measurement	79
4.8.1 Limits of Radiated Emission Measurement	79
4.8.2 Test Procedure	79
4.8.3 Deviation from Test Standard	79

4.8.4 Test Setup.....	80
4.8.5 Test Results	81
5 Pictures of Test Arrangements.....	141
Appendix – Information of the Testing Laboratories	142

Release Control Record

Issue No.	Description	Date Issued
RF200518E05-7	Original release.	Sep. 18, 2020

1 Certificate of Conformity

Product: Terminal

Brand: XAC

Test Model: xCL_AT-150-R3-18U

Sample Status: ENGINEERING SAMPLE

Applicant: XAC AUTOMATION CORP.

Test Date: June 08 to 29, 2020

Standards: FCC Part 27, Subpart H / L
FCC Part 2

The above equipment has been tested by **Bureau Veritas Consumer Products Services (H.K.) Ltd., Taoyuan Branch**, and found compliance with the requirement of the above standards. The test record, data evaluation & Equipment Under Test (EUT) configurations represented herein are true and accurate accounts of the measurements of the sample's EMC characteristics under the conditions specified in this report.

Prepared by :  _____, **Date:** _____ Sep. 18, 2020
Claire Kuan / Specialist

Approved by :  _____, **Date:** _____ Sep. 18, 2020
Clark Lin / Technical Manager

2 Summary of Test Results

Applied Standard: FCC Part 27 & Part 2			
FCC Clause	Test Item	Result	Remarks
2.1046 27.50	Radiated Power	PASS	Meet the requirement of limit.
2.1047	Modulation characteristics	PASS	Meet the requirement
2.1055 27.54	Frequency Stability Stay with the authorized bands of operation	PASS	Meet the requirement of limit.
2.1049 27.53	Occupied Bandwidth	PASS	Meet the requirement of limit.
27.53	Band Edge Measurements	PASS	Meet the requirement of limit.
---	Peak To Average Ratio	PASS	Meet the requirement of limit.
2.1051 27.53	Conducted Spurious Emissions	PASS	Meet the requirement of limit.
2.1053 27.53	Radiated Spurious Emissions	PASS	Meet the requirement of limit. Minimum passing margin is -32.26dB at 8562.5 MHz.

Note:

Determining compliance based on the results of the compliance measurement, not taking into account measurement instrumentation uncertainty

2.1 Measurement Uncertainty

Where relevant, the following measurement uncertainty levels have been estimated for tests performed on the EUT as specified in CISPR 16-4-2:

Measurement	Frequency	Expanded Uncertainty (k=2) (\pm)
Radiated Emissions up to 1 GHz	9kHz ~ 30MHz	3.1 dB
	30MHz ~ 1GHz	5.4 dB
Radiated Emissions above 1 GHz	1GHz ~ 18GHz	5.0 dB
	18GHz ~ 40GHz	5.3 dB

2.2 Test Site and Instruments

For radiated spurious emissions test:

DESCRIPTION & MANUFACTURER	MODEL NO.	SERIAL NO.	CALIBRATED DATE	CALIBRATED UNTIL
Test Receiver Keysight	N9038A	MY54450088	July 03, 2019	July 02, 2020
Pre-Amplifier EMCI	EMC001340	980142	May 25, 2020	May 24, 2021
Loop Antenna Electro-Metrics	EM-6879	264	Feb. 18, 2020	Feb. 17, 2021
RF Cable	NA	LOOPCAB-001	Jan. 08, 2020	Jan. 07, 2021
RF Cable	NA	LOOPCAB-002	Jan. 08, 2020	Jan. 07, 2021
Pre-Amplifier Mini-Circuits	ZFL-1000VH2B	AMP-ZFL-05	Apr. 28, 2020	Apr. 27, 2021
Trilog Broadband Antenna SCHWARZBECK	VULB 9168	9168-361	Nov. 11, 2019	Nov. 10, 2020
RF Cable	8D	966-3-1	Mar. 17, 2020	Mar. 16, 2021
RF Cable	8D	966-3-2	Mar. 17, 2020	Mar. 16, 2021
RF Cable	8D	966-3-3	Mar. 17, 2020	Mar. 16, 2021
Fixed attenuator Mini-Circuits	UNAT-5+	PAD-3m-3-01	Sep. 26, 2019	Sep. 25, 2020
Horn_Antenna SCHWARZBECK	BBHA9120-D	9120D-406	Nov. 24, 2019	Nov. 23, 2020
Pre-Amplifier EMCI	EMC12630SE	980384	Jan. 15, 2020	Jan. 14, 2021
RF Cable	EMC104-SM-SM-1200	160922	Jan. 15, 2020	Jan. 14, 2021
RF Cable	EMC104-SM-SM-2000	180601	June 10, 2019	June 09, 2020
RF Cable	EMC104-SM-SM-6000	180602	June 10, 2019	June 09, 2020
Spectrum Analyzer Keysight	N9030A	MY54490679	July 17, 2019	July 16, 2020
Pre-Amplifier EMCI	EMC184045SE	980387	Jan. 15, 2020	Jan. 14, 2021
Horn_Antenna SCHWARZBECK	BBHA 9170	BBHA9170519	Nov. 24, 2019	Nov. 23, 2020
RF Cable	EMC102-KM-KM-1200	160924	Jan. 15, 2020	Jan. 14, 2021
RF Cable	EMC-KM-KM-4000	200214	Mar. 11, 2020	Mar. 10, 2021
Software	ADT_Radiated_V8.7.08	NA	NA	NA
Antenna Tower & Turn Table Max-Full	MF-7802	MF780208406	NA	NA
Boresight Antenna Fixture	FBA-01	FBA-SIP01	NA	NA

Note:

1. The calibration interval of the above test instruments is 12 months and the calibrations are traceable to NML/ROC and NIST/USA.
2. The test was performed in 966 Chamber No. 3.
3. Tested Date: June 08, 2020

For other test items:

DESCRIPTION & MANUFACTURER	MODEL NO.	SERIAL NO.	CALIBRATED DATE	CALIBRATED UNTIL
Spectrum Analyzer R&S	FSV40	100964	May 29, 2020	May 28, 2021
Spectrum Analyzer Keysight	N9030A	MY54490679	July 17, 2019	July 16, 2020
Power meter Anritsu	ML2495A	1529002	July 26, 2019	July 25, 2020
Power sensor Anritsu	MA2411B	1339443	July 26, 2019	July 25, 2020
Fixed Attenuator Mini-Circuits	MDCS18N-10	MDCS18N-10-01	Apr. 14, 2020	Apr. 13, 2021
AC Power Source Extech Electronics	6205	1440452	NA	NA
DC Power Supply Topward	6603D	795558	NA	NA
Temperature & Humidity Chamber Giant Force	GTH-150-40-SP-AR	MAA0812-008	Jan. 16, 2020	Jan. 15, 2021
Voltage Meter FLUKE	179	89610322	Sep. 25, 2019	Sep. 24, 2020
Mech Switch Absorptive Mini-Circuits	MSP4TA-18+	0140	Feb. 10, 2020	Feb. 09, 2021
FXD ATTEN Mini-Circuits	BW-S3W2+	MN71981	Feb. 10, 2020	Feb. 09, 2021
Software	ADT_RF Test Software V6.6.5.4	NA	NA	NA
Universal Radio Communication Tester R&S	CMU200	121040	Apr. 17, 2020	Apr. 16, 2021
LTE Wireless Communication Test Set Keysight	E7515A	MY56030229	July 31, 2019	July 30, 2020

- Note:**
1. The test was performed in Oven room 2.
 2. The calibration interval of the above test instruments is 12 months and the calibrations are traceable to NML/ROC and NIST/USA.
 3. Tested Date: June 29, 2020

3 General Information

3.1 General Description of EUT

Product	Terminal	
Brand	XAC	
Test Model	xCL_AT-150-R3-18U	
Status of EUT	ENGINEERING SAMPLE	
Power Supply Rating	Refer to note 3	
Modulation Type	LTE	QPSK, 16QAM
Operating Frequency	LTE Band 4 (Channel Bandwidth: 1.4 MHz)	1710.7 ~ 1754.3 MHz
	LTE Band 4 (Channel Bandwidth: 3 MHz)	1711.5 ~ 1753.5 MHz
	LTE Band 4 (Channel Bandwidth: 5 MHz)	1712.5 ~ 1752.5 MHz
	LTE Band 4 (Channel Bandwidth: 10 MHz)	17115 ~ 17550 MHz
	LTE Band 4 (Channel Bandwidth: 15 MHz)	1717.5 ~ 1747.5 MHz
	LTE Band 4 (Channel Bandwidth: 20 MHz)	1720 ~ 1745 MHz
	LTE Band 12 (Channel Bandwidth: 1.4 MHz)	699.7 ~ 715.3 MHz
	LTE Band 12 (Channel Bandwidth: 3 MHz)	700.5 ~ 714.5 MHz
	LTE Band 12 (Channel Bandwidth: 5 MHz)	701.5 ~ 713.5 MHz
	LTE Band 12 (Channel Bandwidth: 10 MHz)	704 ~ 711 MHz
Max. EIRP Power	LTE Band 4 (Channel Bandwidth 1.4MHz)	24.34dBm
	LTE Band 4 (Channel Bandwidth 3MHz)	24.39dBm
	LTE Band 4 (Channel Bandwidth 5MHz)	24.17dBm
	LTE Band 4 (Channel Bandwidth 10MHz)	24.39dBm
	LTE Band 4 (Channel Bandwidth 15MHz)	24.42dBm
	LTE Band 4 (Channel Bandwidth 20MHz)	24.47dBm
Max. ERP Power	LTE Band 12 (Channel Bandwidth 1.4MHz)	24.02dBm
	LTE Band 12 (Channel Bandwidth 3MHz)	23.99dBm
	LTE Band 12 (Channel Bandwidth 5MHz)	24.09dBm
	LTE Band 12 (Channel Bandwidth 10MHz)	24.12dBm

Emission Designator	LTE Band 4 (Channel Bandwidth 1.4MHz)	QPSK: 1M09G7D 16QAM: 1M10D7W
	LTE Band 4 (Channel Bandwidth 3MHz)	QPSK: 2M70G7D 16QAM: 2M68D7W
	LTE Band 4 (Channel Bandwidth 5MHz)	QPSK: 4M51G7D 16QAM: 4M52D7W
	LTE Band 4 (Channel Bandwidth 10MHz)	QPSK: 9M02G7D 16QAM: 9M00D7W
	LTE Band 4 (Channel Bandwidth 15MHz)	QPSK: 13M5G7D 16QAM: 13M5D7W
	LTE Band 4 (Channel Bandwidth 20MHz)	QPSK: 18M0G7D 16QAM: 18M0D7W
	LTE Band 12 (Channel Bandwidth 1.4MHz)	QPSK: 1M09G7D 16QAM: 1M10D7W
	LTE Band 12 (Channel Bandwidth 3MHz)	QPSK: 2M71G7D 16QAM: 2M69D7W
	LTE Band 12 (Channel Bandwidth 5MHz)	QPSK: 4M52G7D 16QAM: 4M52D7W
	LTE Band 12 (Channel Bandwidth 10MHz)	QPSK: 9M02G7D 16QAM: 9M00D7W
Antenna Type	Refer to Note	
Antenna Connector	Refer to Note	
Accessory Device	NA	
Data Cable Supplied	NA	

Note:

1. The EUT has three radios as following table:

Radio 1	Radio 2	Radio 3
WLAN(2.4GHz + 5GHz) + Bluetooth	WWAN(LTE + WCDMA)	NFC

2. Simultaneously transmission condition.

Condition	Technology	
1	WWAN	NFC
2	WWAN	Bluetooth
3	WLAN 2.4GHz	NFC
4	WLAN 5GHz	NFC
5	Bluetooth	NFC

Note: The emission of the simultaneous operation has been evaluated and no non-compliance was found.

3. The EUT must be supplied power adapter and battery as following table:

Adapter (Only test not for sale)		
Brand	Model	Specification
MASS POWER	NBS10B050200VUU	AC Input: 100-240Vac, 0.3A, 50-60Hz DC Output: 5Vdc, 2A
Battery (Option)		
Brand	Model	Specification
Shenzhen Rishengzhi Electronics Technology Co., Ltd.	J625	3.7V, 3000mAh, 11.1Wh

4. The antennas provided to the EUT, please refer to the following table:

Antenna No.	RF Chain No.	Brand	Model	Antenna Net Gain(dBi)	Frequency range	Antenna Type	Connector Type
NFC	Main	XAC	RTOS	13	13.56MHz	wire	None
Wi-Fi BT	Main	AWAN	AYF6P-100002	-2.7	2.4~2.4835GHz	PIFA	i-pex(MHF)
				2.19	5.15~5.85GHz		
				-2.7	2.4~2.4835GHz		
LTE	Main(B2) TX	AWAN	AXF6P-100004	1.55	1850 MHz to 1910 MHz	PIFA	i-pex(MHF)
	Main(B4) TX			1.48	1710 MHz to 1755 MHz		
	Main(B12) TX			2.87	699 MHz to 716 MHz		
	Aux(B2) RX	AWAN	AXF6P-100005	2.36	1930 MHz to 1990 MHz	PIFA	i-pex(MHF)
	Aux(B4) RX			2.91	2110 MHz to 2155 MHz		
	Aux(B12) RX			2.8	729 MHz to 746 MHz		
WCDMA	Main(B2) TX	AWAN	AXF6P-100004	1.55	1850 MHz to 1910 MHz	PIFA	i-pex(MHF)
	Main(B5) TX			1.23	824 MHz to 849 MHz		
	Aux(B2) RX	AWAN	AXF6P-100005	2.36	1930 MHz to 1990 MHz	PIFA	i-pex(MHF)
	Aux(B5) RX			2.84	869 MHz to 894 MHz		

5. The EUT was pre-tested for radiated test under following test modes:

Pre-test Mode	Power
Mode A	Power from Adapter
Mode B	Power from Laptop

From the above modes, the worst radiated test was found in **Mode A**.

6. The above EUT information is declared by manufacturer and for more detailed features description, please refer to the manufacturer's specifications or User's Manual.

7. The above Antenna information is declared by manufacturer and for more detailed features description, please refer to the manufacturer's specifications, the laboratory shall not be held responsible.

3.2 Configuration of System under Test

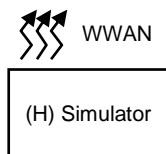
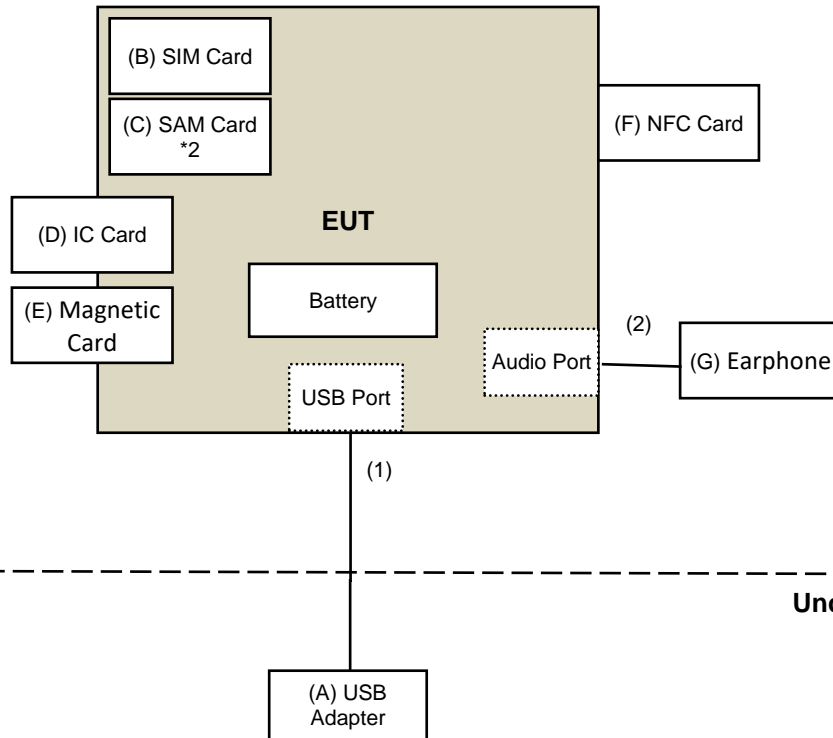

3.2.1 Description of Support Units

The EUT has been tested as an independent unit together with other necessary accessories or support units. The following support units or accessories were used to form a representative test configuration during the tests.

ID	Product	Brand	Model No.	Serial No.	FCC ID	Remarks
A.	USB Adapter	MASS POWER	NBS10B050200VUU	NA	NA	Supplied by client
B.	SIM Card	Keysight	NA	NA	NA	Provided by Lab
C.	SAM Card *2	XAC	NA	NA	NA	Supplied by client
D.	IC Card	XAC	NA	NA	NA	Supplied by client
E.	Magnetic Card	XAC	NA	NA	NA	Supplied by client
F.	NFC Card	XAC	NA	NA	NA	Supplied by client
G.	Earphone	Infinix	NA	NA	NA	Provided by Lab
H.	Simulator	Anritsu	MT8820C	6201127458	NA	Provided by Lab

Note:

1. All power cords of the above support units are non-shielded (1.8m).

ID	Descriptions	Qty.	Length (m)	Shielding (Yes/No)	Cores (Qty.)	Remarks
1.	USB Type C to USB Cable	1	1.2	Yes	0	Supplied by client
2.	Audio	1	1.1	Yes	0	Provided by Lab

3.3 Test Mode Applicability and Tested Channel Detail

LTE Band 4

TEST ITEM	AVAILABLE CHANNEL	TESTED CHANNEL	CHANNEL BANDWIDTH	MODULATION	MODE
EIRP	19957 to 20393	19957, 20175, 20393	1.4MHz	QPSK/16QAM	1RB / 0 RB offset
	19965 to 20385	19965, 20175, 20385	3MHz	QPSK/16QAM	1RB / 0 RB offset
	19975 to 20375	19975, 20175, 20375	5MHz	QPSK/16QAM	1RB / 0 RB offset
	20000 to 20350	20000, 20175, 20350	10MHz	QPSK/16QAM	1RB / 0 RB offset
	20025 to 20325	20025, 20175, 20325	15MHz	QPSK/16QAM	1RB / 0 RB offset
	20050 to 20300	20050, 20175, 20300	20MHz	QPSK/16QAM	1RB / 0 RB offset
Frequency Stability	19957 to 20393	20175	1.4MHz	QPSK	-
	19965 to 20385	20175	3MHz	QPSK	-
	19975 to 20375	20175	5MHz	QPSK	-
	20000 to 20350	20175	10MHz	QPSK	-
	20025 to 20325	20175	15MHz	QPSK	-
	20050 to 20300	20175	20MHz	QPSK	-
Occupied Bandwidth	19957 to 20393	19957, 20175, 20393	1.4MHz	QPSK/16QAM	Full RB
	19965 to 20385	19965, 20175, 20385	3MHz	QPSK/16QAM	Full RB
	19975 to 20375	19975, 20175, 20375	5MHz	QPSK/16QAM	Full RB
	20000 to 20350	20000, 20175, 20350	10MHz	QPSK/16QAM	Full RB
	20025 to 20325	20025, 20175, 20325	15MHz	QPSK/16QAM	Full RB
	20050 to 20300	20050, 20175, 20300	20MHz	QPSK/16QAM	Full RB
Peak to Average Ratio	19957 to 20393	19957, 20175, 20393	1.4MHz	QPSK/16QAM	Full RB
	19965 to 20385	19965, 20175, 20385	3MHz	QPSK/16QAM	Full RB
	19975 to 20375	19975, 20175, 20375	5MHz	QPSK/16QAM	Full RB
	20000 to 20350	20000, 20175, 20350	10MHz	QPSK/16QAM	Full RB
	20025 to 20325	20025, 20175, 20325	15MHz	QPSK/16QAM	Full RB
	20050 to 20300	20050, 20175, 20300	20MHz	QPSK/16QAM	Full RB
Band Edge	19957 to 20393	19957	1.4MHz	QPSK	1 RB / 0 RB Offset
		20393			1 RB / 5 RB Offset
		19957, 20393			6 RB / 0 RB Offset
	19965 to 20385	19965	3MHz	QPSK	1 RB / 0 RB Offset
		20385			1 RB / 14 RB Offset
		19965, 20385			15 RB / 0 RB Offset
	19975 to 20375	19975	5MHz	QPSK	1 RB / 0 RB Offset
		20375			1 RB / 24 RB Offset
		19975, 20375			25 RB / 0 RB Offset
	20000 to 20350	20000	10MHz	QPSK	1 RB / 0 RB Offset
		20350			1 RB / 49 RB Offset
		20000, 20350			50 RB / 0 RB Offset
	20025 to 20325	20025	15MHz	QPSK	1 RB / 0 RB Offset
		20325			1 RB / 74 RB Offset
		20025, 20325			75 RB / 0 RB Offset
	20050 to 20300	20050	20MHz	QPSK	1 RB / 0 RB Offset
		20300			1 RB / 99 RB Offset
		20050, 20300			100 RB / 0 RB Offset

Conducted Emission	19957 to 20393	19957, 20175, 20393	1.4MHz	QPSK	1 RB / 0 RB Offset
	19965 to 20385	19965, 20175, 20385	3MHz	QPSK	1 RB / 0 RB Offset
	19975 to 20375	19975, 20175, 20375	5MHz	QPSK	1 RB / 0 RB Offset
	20000 to 20350	20000, 20175, 20350	10MHz	QPSK	1 RB / 0 RB Offset
	20025 to 20325	20025, 20175, 20325	15MHz	QPSK	1 RB / 0 RB Offset
	20050 to 20300	20050, 20175, 20300	20MHz	QPSK	1 RB / 0 RB Offset
Radiated Emission	19957 to 20393	19957, 20175, 20393	1.4MHz	QPSK	1 RB / 0 RB Offset
	19965 to 20385	19965, 20175, 20385	3MHz	QPSK	1 RB / 0 RB Offset
	19975 to 20375	19975, 20175, 20375	5MHz	QPSK	1 RB / 0 RB Offset
	20000 to 20350	20000, 20175, 20350	10MHz	QPSK	1 RB / 0 RB Offset
	20025 to 20325	20025, 20175, 20325	15MHz	QPSK	1 RB / 0 RB Offset
	20050 to 20300	20050, 20175, 20300	20MHz	QPSK	1 RB / 0 RB Offset

NOTE:

All supported modulation types were evaluated. The Worst case of QPSK was selected. Therefore, the Frequency Stability, Band Edge, Condcudeted Emission and Radiated Emission were presented under QPSK mode only.

Test Condition:

Test Item	Environmental Conditions	Input Power (System)	Tested By
EIRP	25deg. C, 60%RH	120Vac, 60Hz	Jynuchun Lin
Frequency Stability	25deg. C, 60%RH	5Vdc	Jynuchun Lin
Occupied Bandwidth	25deg. C, 60%RH	120Vac, 60Hz	Jynuchun Lin
Band Edge	25deg. C, 60%RH	120Vac, 60Hz	Jynuchun Lin
Peak to Average Ratio	25deg. C, 60%RH	120Vac, 60Hz	Jynuchun Lin
Condcudeted Emission	25deg. C, 60%RH	120Vac, 60Hz	Jynuchun Lin
Radiated Emission Below 1GHz	25deg. C, 75%RH	120Vac, 60Hz	Kevin Ko
Radiated Emission Above 1GHz	25deg. C, 75%RH	120Vac, 60Hz	Kevin Ko

LTE Band 12

TEST ITEM	AVAILABLE CHANNEL	TESTED CHANNEL	CHANNEL BANDWIDTH	MODULATION	MODE
ERP	23017 to 23173	23017, 23095, 23173	1.4MHz	QPSK/16QAM	1RB / 0 RB offset
	23025 to 23165	23025, 23095, 23165	3MHz	QPSK/16QAM	1RB / 0 RB offset
	23035 to 23155	23035, 23095, 23155	5MHz	QPSK/16QAM	1RB / 0 RB offset
	23060 to 23130	23060, 23095, 23130	10MHz	QPSK/16QAM	1RB / 0 RB offset
Frequency Stability	23017 to 23173	23095	1.4MHz	QPSK	-
	23025 to 23165	23095	3MHz	QPSK	-
	23035 to 23155	23095	5MHz	QPSK	-
	23060 to 23130	23095	10MHz	QPSK	-
Occupied Bandwidth	23017 to 23173	23017, 23095, 23173	1.4MHz	QPSK/16QAM	Full RB
	23025 to 23165	23025, 23095, 23165	3MHz	QPSK/16QAM	Full RB
	23035 to 23155	23035, 23095, 23155	5MHz	QPSK/16QAM	Full RB
	23060 to 23130	23060, 23095, 23130	10MHz	QPSK/16QAM	Full RB
Peak to Average Ratio	23017 to 23173	23017, 23095, 23173	1.4MHz	QPSK/16QAM	Full RB
	23025 to 23165	23025, 23095, 23165	3MHz	QPSK/16QAM	Full RB
	23035 to 23155	23035, 23095, 23155	5MHz	QPSK/16QAM	Full RB
	23060 to 23130	23060, 23095, 23130	10MHz	QPSK/16QAM	Full RB
Band Edge	23017 to 23173	23017	1.4MHz	QPSK	1 RB / 0 RB Offset
		23173			1 RB / 5 RB Offset
		23017, 23173			6 RB / 0 RB Offset
	23025 to 23165	23025	3MHz	QPSK	1 RB / 0 RB Offset
		23165			1 RB / 14 RB Offset
		23025, 23165			15 RB / 0 RB Offset
	23035 to 23155	23035	5MHz	QPSK	1 RB / 0 RB Offset
		23155			1 RB / 24 RB Offset
		23035, 23155			25 RB / 0 RB Offset
	23060 to 23130	23060	10MHz	QPSK	1 RB / 0 RB Offset
		23130			1 RB / 49 RB Offset
		23060, 23130			50 RB / 0 RB Offset
Conducted Emission	23017 to 23173	23017, 23095, 23173	1.4MHz	QPSK	1RB / 0 RB offset
	23025 to 23165	23025, 23095, 23165	3MHz	QPSK	1RB / 0 RB offset
	23035 to 23155	23035, 23095, 23155	5MHz	QPSK	1RB / 0 RB offset
	23060 to 23130	23060, 23095, 23130	10MHz	QPSK	1RB / 0 RB offset
Radiated Emission	23017 to 23173	23017, 23095, 23173	1.4MHz	QPSK	1RB / 0 RB offset
	23025 to 23165	23025, 23095, 23165	3MHz	QPSK	1RB / 0 RB offset
	23035 to 23155	23035, 23095, 23155	5MHz	QPSK	1RB / 0 RB offset
	23060 to 23130	23060, 23095, 23130	10MHz	QPSK	1RB / 0 RB offset

NOTE:

All supported modulation types were evaluated. The Worst case of QPSK was selected. Therefore, the Frequency Stability, Band Edge, Condcudeted Emission and Radiated Emission were presented under QPSK mode only.

Test Condition:

Test Item	Environmental Conditions	Input Power (System)	Tested By
ERP	25deg. C, 60%RH	120Vac, 60Hz	Jynuchun Lin
Frequency Stability	25deg. C, 60%RH	5Vdc	Jynuchun Lin
Occupied Bandwidth	25deg. C, 60%RH	120Vac, 60Hz	Jynuchun Lin
Band Edge	25deg. C, 60%RH	120Vac, 60Hz	Jynuchun Lin
Peak to Average Ratio	25deg. C, 60%RH	120Vac, 60Hz	Jynuchun Lin
Conducuted Emission	25deg. C, 60%RH	120Vac, 60Hz	Jynuchun Lin
Radiated Emission Below 1GHz	25deg. C, 75%RH	120Vac, 60Hz	Kevin Ko
Radiated Emission Above 1GHz	25deg. C, 75%RH	120Vac, 60Hz	Kevin Ko

3.4 EUT Operating Conditions

The communication simulator station system controlled a EUT to export maximum output power under transmission mode and specific channel frequency

3.5 General Description of Applied Standards and references

The EUT is a RF Product. According to the specifications of the manufacturer, it must comply with the requirements of the following standards and references:

Test standard:

FCC 47 CFR Part 2

FCC 47 CFR Part 27, Subpart H / L

ANSI/TIA/EIA-603-E 2016

ANSI 63.26-2015

All test items have been performed and recorded as per the above standards.

References Test Guidance :

KDB 971168 D01 Power Meas License Digital Systems v03r01

All test items have been performed as a reference to the above KDB test guidance.

4 Test Types and Results

4.1 Output Power Measurement

4.1.1 Limits of Output Power Measurement

For section 27.50(d)(4): Fixed, mobile, and portable (hand-held) stations operating in the 1710-1755 MHz band and mobile and portable stations operating in the 1695-1710 MHz and 1755-1780 MHz bands are limited to 1 watt EIRP.

For section 27.50(b)(10): Portable stations (hand-held devices) operating in the 698-787 MHz band are limited to 3 watts ERP.

4.1.2 Test Procedures

Conducted Power Measurement:

The EUT was set up for the maximum power with LTE link data modulation and link up with simulator. Set the EUT to transmit under low, middle and high channel and difference RB size/ RB offset for difference bandwidth record the power level shown on power meter.

EIRP / ERP Measurement:

- a. $EIRP = \text{Conducted Output power level} + \text{Antenna gain}$.
- b. ERP power can be calculated from EIRP power by subtracting the gain of dipole, $ERP \text{ power} = EIRP \text{ power} - 2.15dBi$.
- c. $ERP = \text{Conducted Output power level} + \text{Antenna gain (dBi)} - \text{Isotropically Factor (2.15dB)}$

4.1.3 Test Setup

Conducted Power Measurement:

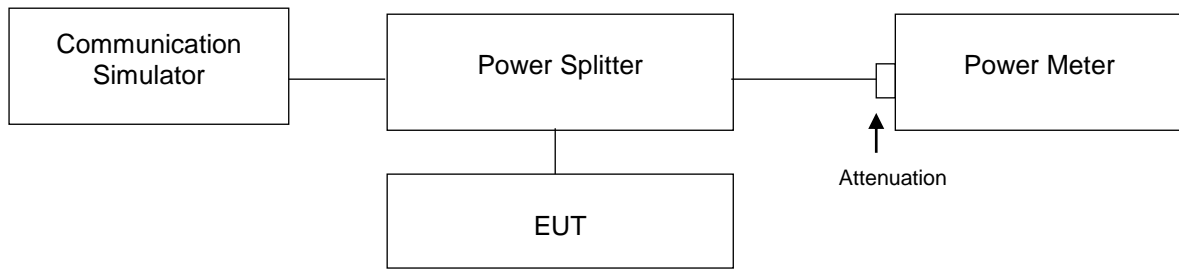

4.1.4 Test Results

CONDUCTED OUTPUT POWER (dBm)
LTE Band 4

Band / BW	RB Size	RB Offset	QPSK			3GPP MPR (dB)	16QAM			3GPP MPR (dB)
			Low CH	Mid CH	High CH		Low CH	Mid CH	High CH	
			19957	20175	20393		19957	20175	20393	
			1710.7	1732.5	1754.3		1710.7	1732.5	1754.3	
			MHz	MHz	MHz		MHz	MHz	MHz	
4 / 1.4M	1	0	22.49	22.58	22.86	0	21.72	21.72	21.83	1
	1	2	22.21	22.48	22.60	0	21.13	21.32	21.58	1
	1	5	22.11	22.22	22.38	0	20.94	21.11	21.44	1
	3	0	22.49	22.68	22.79	0	21.43	21.65	21.92	1
	3	1	22.44	22.51	22.56	0	21.33	21.44	21.61	1
	3	3	22.18	22.29	22.46	0	21.23	21.32	21.47	1
	6	0	21.33	21.58	21.73	1	20.33	20.56	20.82	2

Band / BW	RB Size	RB Offset	QPSK			3GPP MPR (dB)	16QAM			3GPP MPR (dB)
			Low CH	Mid CH	High CH		Low CH	Mid CH	High CH	
			19965	20175	20385		19965	20175	20385	
			1711.5	1732.5	1753.5		1711.5	1732.5	1753.5	
			MHz	MHz	MHz		MHz	MHz	MHz	
4 / 3M	1	0	22.57	22.63	22.91	0	21.66	21.82	21.88	1
	1	7	22.25	22.53	22.61	0	21.12	21.36	21.57	1
	1	14	22.09	22.26	22.56	0	21.03	21.29	21.37	1
	8	0	21.61	21.75	21.80	1	20.54	20.59	20.94	2
	8	3	21.31	21.58	21.66	1	20.30	20.43	20.68	2
	8	7	21.23	21.31	21.49	1	20.15	20.38	20.56	2
	15	0	21.41	21.61	21.89	1	20.35	20.55	20.74	2

Band / BW	RB Size	RB Offset	QPSK			3GPP MPR (dB)	16QAM			3GPP MPR (dB)
			Low CH	Mid CH	High CH		Low CH	Mid CH	High CH	
			19975	20175	20375		19975	20175	20375	
			1712.5	1732.5	1752.5		1712.5	1732.5	1752.5	
			MHz	MHz	MHz		MHz	MHz	MHz	
4 / 5M	1	0	22.56	22.69	22.68	0	21.71	21.81	21.71	1
	1	12	22.38	22.43	22.61	0	21.15	21.25	21.48	1
	1	24	22.12	22.23	22.36	0	20.95	21.14	21.31	1
	12	0	21.50	21.70	21.79	1	20.61	20.65	20.82	2
	12	6	21.28	21.60	21.51	1	20.30	20.55	20.65	2
	12	13	21.15	21.25	21.48	1	20.29	20.44	20.57	2
	25	0	21.41	21.62	21.70	1	20.46	20.51	20.70	2

Band / BW	RB Size	RB Offset	QPSK			3GPP MPR (dB)	16QAM			3GPP MPR (dB)
			Low CH	Mid CH	High CH		Low CH	Mid CH	High CH	
			20000	20175	20350		20000	20175	20350	
			1715	1732.5	1750		1715	1732.5	1750	
			MHz	MHz	MHz		MHz	MHz	MHz	
4 / 10M	1	0	22.40	22.70	22.91	0	21.62	21.79	21.83	1
	1	24	22.16	22.42	22.74	0	21.13	21.39	21.51	1
	1	49	22.16	22.41	22.50	0	20.98	21.28	21.27	1
	25	0	21.37	21.61	21.96	1	20.50	20.59	20.95	2
	25	12	21.33	21.39	21.65	1	20.27	20.53	20.65	2
	25	25	21.22	21.35	21.47	1	20.19	20.42	20.64	2
	50	0	21.37	21.47	21.82	1	20.47	20.49	20.79	2

Band / BW	RB Size	RB Offset	QPSK			3GPP MPR (dB)	16QAM			3GPP MPR (dB)
			Low CH	Mid CH	High CH		Low CH	Mid CH	High CH	
			20025	20175	20325		20025	20175	20325	
			1717.5	1732.5	1747.5		1717.5	1732.5	1747.5	
			MHz	MHz	MHz		MHz	MHz	MHz	
4 / 15M	1	0	22.63	22.79	22.94	0	21.71	21.95	21.92	1
	1	37	22.31	22.47	22.72	0	21.18	21.33	21.57	1
	1	74	22.14	22.31	22.59	0	21.04	21.29	21.43	1
	36	0	21.55	21.70	21.94	1	20.56	20.83	20.91	2
	36	19	21.37	21.61	21.71	1	20.36	20.51	20.76	2
	36	39	21.18	21.44	21.60	1	20.35	20.43	20.69	2
	75	0	21.44	21.60	21.79	1	20.44	20.64	20.80	2

Band / BW	RB Size	RB Offset	QPSK			3GPP MPR (dB)	16QAM			3GPP MPR (dB)
			Low CH	Mid CH	High CH		Low CH	Mid CH	High CH	
			20050	20175	20300		20050	20175	20300	
			1720	1732.5	1745		1720	1732.5	1745	
			MHz	MHz	MHz		MHz	MHz	MHz	
4 / 20M	1	0	22.63	22.80	22.99	0	21.78	21.95	21.94	1
	1	50	22.38	22.55	22.74	0	21.25	21.42	21.61	1
	1	99	22.24	22.41	22.60	0	21.13	21.30	21.49	1
	50	0	21.62	21.79	21.98	1	20.66	20.83	20.99	2
	50	25	21.45	21.62	21.81	1	20.42	20.59	20.78	2
	50	50	21.28	21.45	21.64	1	20.35	20.52	20.71	2
	100	0	21.53	21.70	21.89	1	20.49	20.66	20.85	2

LTE Band 12

Band / BW	RB Size	RB Offset	QPSK			3GPP MPR (dB)	16QAM			3GPP MPR (dB)	
			Low CH	Mid CH	High CH		Low CH	Mid CH	High CH		
			23017	23095	23173		23017	23095	23173		
			699.7	707.5	715.3		699.7	707.5	715.3		
			MHz	MHz	MHz						
12 / 1.4M	1	0	23.03	23.30	23.29	0	21.90	22.11	22.08	1	
	1	2	22.80	23.09	22.97	0	21.49	21.53	21.62	1	
	1	5	22.87	23.07	23.00	0	21.65	21.89	21.94	1	
	3	0	21.75	21.90	21.91	0	20.64	20.86	20.90	1	
	3	1	21.75	21.94	21.96	0	20.89	21.11	21.07	1	
	3	3	21.78	21.97	21.84	0	20.83	21.12	21.04	1	
	6	0	21.62	21.96	21.89	1	20.69	20.90	20.92	2	

Band / BW	RB Size	RB Offset	QPSK			3GPP MPR (dB)	16QAM			3GPP MPR (dB)	
			Low CH	Mid CH	High CH		Low CH	Mid CH	High CH		
			23025	23095	23165		23025	23095	23165		
			700.5	707.5	714.5		700.5	707.5	714.5		
			MHz	MHz	MHz						
12 / 3M	1	0	23.09	23.25	23.27	0	21.84	22.02	22.14	1	
	1	7	22.74	23.00	22.98	0	21.32	21.58	21.54	1	
	1	14	23.00	23.21	23.13	0	21.71	21.88	22.01	1	
	8	0	21.83	21.92	22.05	1	20.59	20.84	20.94	2	
	8	3	21.64	21.85	21.93	1	21.02	21.07	21.07	2	
	8	7	21.70	21.79	21.91	1	20.77	21.05	21.20	2	
	15	0	21.71	21.83	21.89	1	20.62	20.93	20.96	2	

Band / BW	RB Size	RB Offset	QPSK			3GPP MPR (dB)	16QAM			3GPP MPR (dB)	
			Low CH	Mid CH	High CH		Low CH	Mid CH	High CH		
			23035	23095	23155		23035	23095	23155		
			701.5	707.5	713.5		701.5	707.5	713.5		
			MHz	MHz	MHz						
12 / 5M	1	0	23.17	23.37	23.31	0	21.95	22.11	22.10	1	
	1	12	22.85	23.05	23.17	0	21.49	21.72	21.75	1	
	1	24	23.05	23.24	23.26	0	21.79	21.95	21.99	1	
	12	0	21.85	22.03	22.04	1	20.73	20.95	20.92	2	
	12	6	21.84	22.04	21.97	1	20.94	21.23	21.19	2	
	12	13	21.74	21.94	21.99	1	20.95	21.13	21.18	2	
	25	0	21.72	21.99	22.03	1	20.75	20.95	21.06	2	

Band / BW	RB Size	RB Offset	QPSK			3GPP MPR (dB)	16QAM			3GPP MPR (dB)	
			Low CH	Mid CH	High CH		Low CH	Mid CH	High CH		
			23060	23095	23130		23060	23095	23130		
			704	707.5	711		704	707.5	711		
			MHz	MHz	MHz						
12 / 10M	1	0	23.17	23.37	23.40	0	21.97	22.17	22.20	1	
	1	24	22.95	23.15	23.18	0	21.54	21.74	21.77	1	
	1	49	23.05	23.25	23.28	0	21.84	22.04	22.07	1	
	25	0	21.87	22.07	22.10	1	20.75	20.95	20.98	2	
	25	12	21.84	22.04	22.07	1	21.03	21.23	21.26	2	
	25	25	21.83	22.03	22.06	1	20.98	21.18	21.21	2	
	50	0	21.80	22.00	22.03	1	20.83	21.03	21.06	2	

EIRP / ERP POWER

LTE Band 4

Band / BW	RB Size	RB Offset	QPSK			3GPP MPR (dB)	16QAM			3GPP MPR (dB)
			Low CH	Mid CH	High CH		Low CH	Mid CH	High CH	
			19957	20175	20393		19957	20175	20393	
			1710.7	1732.5	1754.3		1710.7	1732.5	1754.3	
MHz	MHz	MHz	MHz	MHz	MHz					
4 / 1.4M	1	0	22.49	22.58	22.86	0	21.72	21.72	21.83	1
Gain (dBi)		1.48	1.48	1.48	1.48		1.48	1.48		
Max EIRP Power (dBm)		23.97	24.06	24.34	23.20		23.20	23.31		

Band / BW	RB Size	RB Offset	QPSK			3GPP MPR (dB)	16QAM			3GPP MPR (dB)
			Low CH	Mid CH	High CH		Low CH	Mid CH	High CH	
			19965	20175	20385		19965	20175	20385	
			1711.5	1732.5	1753.5		1711.5	1732.5	1753.5	
MHz	MHz	MHz	MHz	MHz	MHz					
4 / 3M	1	0	22.57	22.63	22.91	0	21.66	21.82	21.88	1
Gain (dBi)		1.48	1.48	1.48	1.48		1.48			
Max EIRP Power (dBm)		24.05	24.11	24.39	23.14		23.30	23.36		

Band / BW	RB Size	RB Offset	QPSK			3GPP MPR (dB)	16QAM			3GPP MPR (dB)
			Low CH	Mid CH	High CH		Low CH	Mid CH	High CH	
			19975	20175	20375		19975	20175	20375	
			1712.5	1732.5	1752.5		1712.5	1732.5	1752.5	
MHz	MHz	MHz	MHz	MHz	MHz					
4 / 5M	1	0	22.56	22.69	22.68	0	21.71	21.81	21.71	1
Gain (dBi)		1.48	1.48	1.48	1.48		1.48			
Max EIRP Power (dBm)		24.04	24.17	24.16	23.19		23.29	23.19		

Band / BW	RB Size	RB Offset	QPSK			3GPP MPR (dB)	16QAM			3GPP MPR (dB)
			Low CH	Mid CH	High CH		Low CH	Mid CH	High CH	
			20000	20175	20350		20000	20175	20350	
			1715	1732.5	1750		1715	1732.5	1750	
MHz	MHz	MHz	MHz	MHz	MHz					
4 / 10M	1	0	22.40	22.70	22.91	0	21.62	21.79	21.83	1
Gain (dBi)		1.48	1.48	1.48	1.48		1.48			
Max EIRP Power (dBm)		23.88	24.18	24.39	23.10		23.27	23.31		

Band / BW	RB Size	RB Offset	QPSK			3GPP MPR (dB)	16QAM			3GPP MPR (dB)
			Low CH	Mid CH	High CH		Low CH	Mid CH	High CH	
			20025	20175	20325		20025	20175	20325	
			1717.5	1732.5	1747.5		1717.5	1732.5	1747.5	
			MHz	MHz	MHz	MHz	MHz	MHz		
4 / 15M	1	0	22.63	22.79	22.94	0	21.71	21.95	21.92	1
Gain (dBi)			1.48	1.48	1.48		1.48	1.48	1.48	
Max EIRP Power (dBm)			24.11	24.27	24.42		23.19	23.43	23.40	

Band / BW	RB Size	RB Offset	QPSK			3GPP MPR (dB)	16QAM			3GPP MPR (dB)
			Low CH	Mid CH	High CH		Low CH	Mid CH	High CH	
			20050	20175	20300		20050	20175	20300	
			1720	1732.5	1745		1720	1732.5	1745	
			MHz	MHz	MHz	MHz	MHz	MHz		
4 / 20M	1	0	22.63	22.80	22.99	0	21.78	21.95	21.94	1
Gain (dBi)			1.48	1.48	1.48		1.48	1.48	1.48	
Max EIRP Power (dBm)			24.11	24.28	24.47		23.26	23.43	23.42	

LTE Band 12

Band / BW	RB Size	RB Offset	QPSK			3GPP MPR (dB)	16QAM			3GPP MPR (dB)
			Low CH	Mid CH	High CH		Low CH	Mid CH	High CH	
			23017	23095	23173		23017	23095	23173	
			699.7	707.5	715.3		699.7	707.5	715.3	
	MHz	MHz	MHz	MHz	MHz	MHz				
12 / 1.4M	1	0	23.03	23.30	23.29	0	21.90	22.11	22.08	1
Gain (dBi)		2.87	2.87	2.87	2.87		2.87	2.87		
Isotropically Factor (dBc)		2.15	2.15	2.15	2.15		2.15	2.15		
Max ERP Power (dBm)		23.75	24.02	24.01	22.62		22.83	22.80		

Band / BW	RB Size	RB Offset	QPSK			3GPP MPR (dB)	16QAM			3GPP MPR (dB)
			Low CH	Mid CH	High CH		Low CH	Mid CH	High CH	
			23025	23095	23165		23025	23095	23165	
			700.5	707.5	714.5		700.5	707.5	714.5	
	MHz	MHz	MHz	MHz	MHz	MHz				
12 / 3M	1	0	23.09	23.25	23.27	0	21.84	22.02	22.14	1
Gain (dBi)		2.87	2.87	2.87	2.87		2.87			
Isotropically Factor (dBc)		2.15	2.15	2.15	2.15		2.15			
Max ERP Power (dBm)		23.81	23.97	23.99	22.56		22.74	22.86		

Band / BW	RB Size	RB Offset	QPSK			3GPP MPR (dB)	16QAM			3GPP MPR (dB)
			Low CH	Mid CH	High CH		Low CH	Mid CH	High CH	
			23035	23095	23155		23035	23095	23155	
			701.5	707.5	713.5		701.5	707.5	713.5	
	MHz	MHz	MHz	MHz	MHz	MHz				
12 / 5M	1	0	23.17	23.37	23.31	0	21.95	22.11	22.10	1
Gain (dBi)		2.87	2.87	2.87	2.87		2.87			
Isotropically Factor (dBc)		2.15	2.15	2.15	2.15		2.15			
Max ERP Power (dBm)		23.89	24.09	24.03	22.67		22.83	22.82		

Band / BW	RB Size	RB Offset	QPSK			3GPP MPR (dB)	16QAM			3GPP MPR (dB)
			Low CH	Mid CH	High CH		Low CH	Mid CH	High CH	
			23060	23095	23130		23060	23095	23130	
			704	707.5	711		704	707.5	711	
	MHz	MHz	MHz	MHz	MHz	MHz				
12 / 10M	1	0	23.17	23.37	23.40	0	21.97	22.17	22.20	1
Gain (dBi)		2.87	2.87	2.87	2.87		2.87			
Isotropically Factor (dBc)		2.15	2.15	2.15	2.15		2.15			
Max ERP Power (dBm)		23.89	24.09	24.12	22.69		22.89	22.92		

4.2 Modulation characteristics Measurement

4.2.1 Limits of Modulation characteristics

N/A

4.2.2 Test Procedure

Connect the EUT to Communication Simulator via the antenna connector. The frequency band is set as EUT supported Modulation and Channels, the EUT output is matched with 50 ohm load, the waveform quality and constellation of the EUT was tested.

4.2.3 Test Setup



4.2.4 Test Results

LTE Band 4

**QPSK / Channel Bandwidth: 20MHz /
Frequency: 1732.5 MHz / Chain 0**

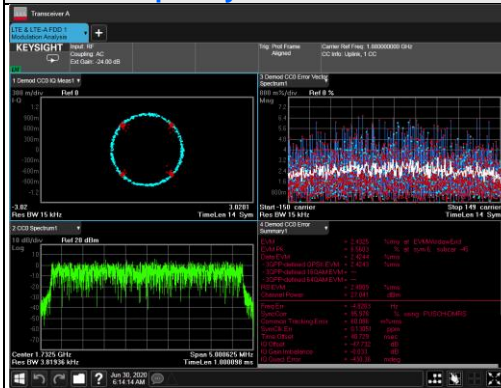

**16QAM / Channel Bandwidth: 20MHz /
Frequency: 1732.5 MHz / Chain 0**

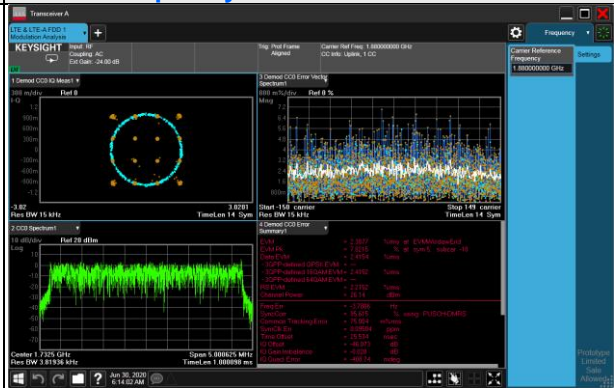

LTE Band 12

**QPSK / Channel Bandwidth: 10MHz /
Frequency: 707.5 MHz / Chain 0**



**16QAM / Channel Bandwidth: 10MHz /
Frequency: 707.5 MHz / Chain 0**

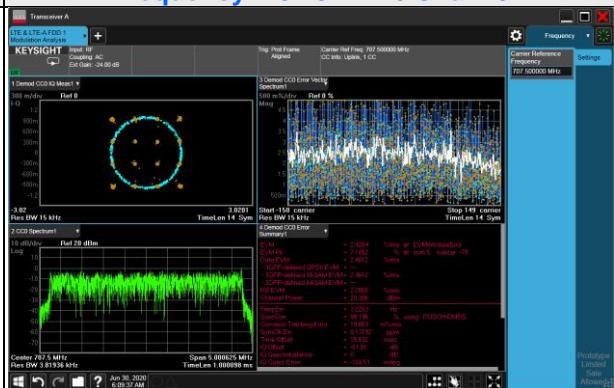

4.3 Frequency Stability Measurement

4.3.1 Limits of Frequency Stability Measurement

The frequency stability shall be sufficient to ensure that the fundamental emissions stay within the authorized bands of operation.

According to the FCC part 2.1055 shall be tested the frequency stability. The rule is defined that "The frequency stability shall be sufficient to ensure that the fundamental emission stays within the authorized frequency block." The test extreme voltage is according to the 2.1055(d)(1) Vary primary supply voltage from 85 to 115 percent of the nominal value for other than hand carried battery equipment and the extreme temperature rule is comply with specification of EUT $-30^{\circ}\text{C} \sim 50^{\circ}\text{C}$.

4.3.2 Test Procedure

- Device is placed at the oven room. The oven room could control the temperatures and humidity. Power warm up is at least 15 min and power applied should perform before recording frequency error.
- EUT is connected the external power supply to control the DC input power. The test voltage range is from minimum to maximum working voltage. Each step shall be record the frequency error rate.
- The temperature range step is 10 degrees in this test items. All temperature levels shall be hold the $\pm 0.5^{\circ}\text{C}$ during the measurement testing. The each temperature step shall be at least 0.5 hours, consider the EUT could be test under the stability condition.

NOTE: The frequency error was recorded frequency error from the communication simulator.

4.3.3 Test Setup

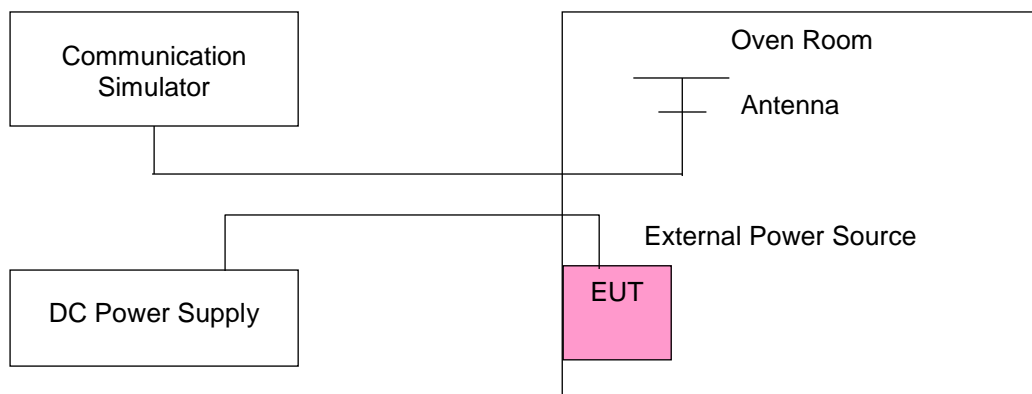

4.3.4 Test Results

LTE Band 4

Voltage (Volts)	Frequency Error (ppm)						Limit (ppm)
	1.4MHz	3MHz	5MHz	10MHz	15MHz	20MHz	
2.805	0.026	0.028	0.021	0.023	0.020	0.013	2.5
3.795	0.023	0.014	0.013	0.025	0.013	0.018	2.5

Temp. (°C)	Frequency Error (ppm)						Limit (ppm)
	1.4MHz	3MHz	5MHz	10MHz	15MHz	20MHz	
50	0.018	0.021	0.026	0.026	0.014	0.018	2.5
40	0.022	0.018	0.013	0.020	0.028	0.016	2.5
30	0.018	0.013	0.012	0.023	0.024	0.025	2.5
20	0.017	0.019	0.015	0.018	0.023	0.020	2.5
10	0.016	0.023	0.018	0.012	0.025	0.017	2.5
0	0.020	0.025	0.022	0.016	0.028	0.019	2.5
-10	0.013	0.022	0.014	0.026	0.025	0.014	2.5
-20	0.012	0.018	0.023	0.028	0.012	0.012	2.5
-30	0.017	0.017	0.018	0.019	0.018	0.026	2.5

LTE Band 12

Voltage (Volts)	Frequency Error (ppm)				Limit (ppm)
	1.4MHz	3MHz	5MHz	10MHz	
2.805	0.068	0.038	0.038	0.068	2.5
3.795	0.040	0.035	0.047	0.052	2.5

Temp. (°C)	Frequency Error (ppm)				Limit (ppm)
	1.4MHz	3MHz	5MHz	10MHz	
50	0.037	0.028	0.037	0.037	2.5
40	0.069	0.034	0.051	0.069	2.5
30	0.052	0.062	0.052	0.044	2.5
20	0.044	0.066	0.031	0.035	2.5
10	0.055	0.068	0.040	0.037	2.5
0	0.047	0.054	0.066	0.041	2.5
-10	0.031	0.041	0.042	0.055	2.5
-20	0.047	0.035	0.047	0.033	2.5
-30	0.055	0.037	0.051	0.059	2.5

4.4 Emission Bandwidth Measurement

4.4.1 Limits of Emission Bandwidth Measurement

-26dB Bandwidth

According to FCC 27.53 specified that emission bandwidth is defined as the width of the signal between two points, one below the carrier center frequency and one above the carrier center frequency, outside of which all emissions are attenuated at least 26dB below the transmitter power.

Occupied Bandwidth

The EUT makes a call to the communication simulator. All measurements were done at low, middle and high operational frequency range. The communication simulator station system controlled a EUT to export maximum output power under transmission mode and specific channel frequency. Use OBW measurement function of Spectrum analyzer to measure 99 % occupied bandwidth.

4.4.2 Test Procedure

The transmitter output was connected to the spectrum analyzer through an attenuator. The bandwidth of the fundamental frequency was measured by spectrum analyzer with $RBW \geq 1\% \times OBW$ and $VBW \geq 3 \times VBW$.

4.4.3 Test Setup

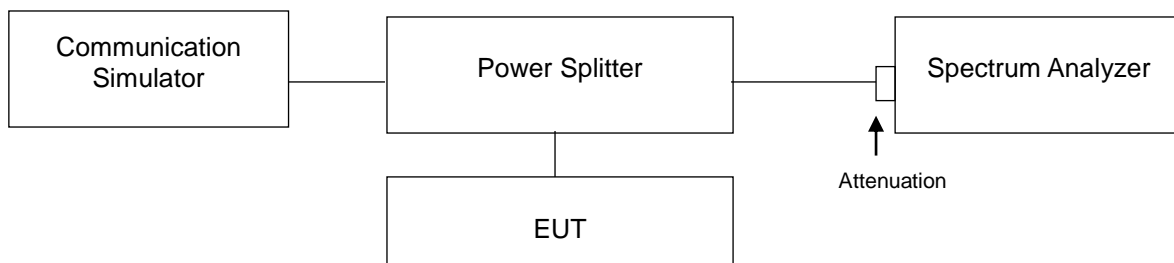

4.4.4 Test Results (-26dB Bandwidth)

LTE Band 4							
Channel Bandwidth 1.4MHz				Channel Bandwidth 3MHz			
Channel	Frequency (MHz)	-26dB Bandwidth (MHz)		Channel	Frequency (MHz)	-26dB Bandwidth (MHz)	
		QPSK	16QAM			QPSK	16QAM
19957	1710.7	1.29	1.29	19965	1711.5	2.97	2.95
20175	1732.5	1.30	1.28	20175	1732.5	2.99	2.97
20393	1754.3	1.29	1.30	20385	1753.5	2.97	2.98
Channel Bandwidth 5MHz				Channel Bandwidth 10MHz			
Channel	Frequency (MHz)	-26dB Bandwidth (MHz)		Channel	Frequency (MHz)	-26dB Bandwidth (MHz)	
		QPSK	16QAM			QPSK	16QAM
19975	1712.5	5.01	5.00	20000	1715	9.85	9.89
20175	1732.5	5.03	4.99	20175	1732.5	9.89	9.93
20375	1752.5	5.04	5.01	20350	1750	9.89	9.91
Channel Bandwidth 15MHz				Channel Bandwidth 20MHz			
Channel	Frequency (MHz)	-26dB Bandwidth (MHz)		Channel	Frequency (MHz)	-26dB Bandwidth (MHz)	
		QPSK	16QAM			QPSK	16QAM
20025	1717.5	14.73	14.75	20050	1720	19.42	19.45
20175	1732.5	14.74	14.74	20175	1732.5	19.51	19.55
20325	1747.5	14.70	14.74	20300	1745	19.45	19.54

Spectrum Plot of Worst Value

1.4MHz / QPSK

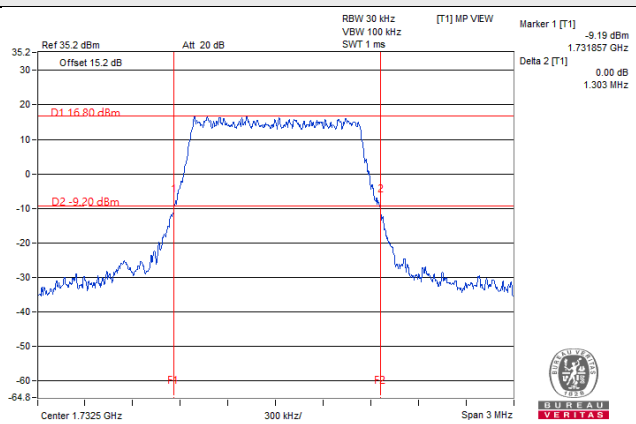

3MHz / QPSK

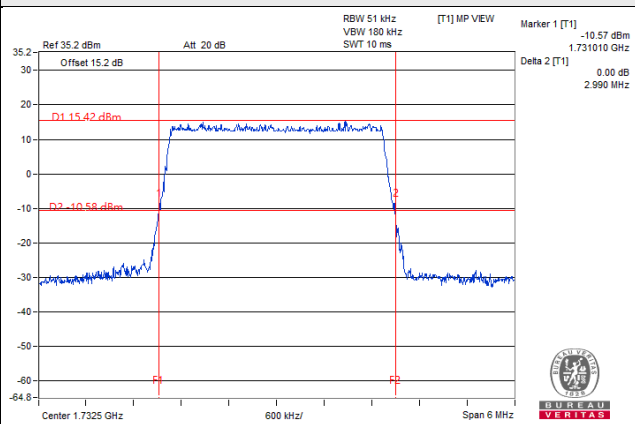

5MHz / QPSK

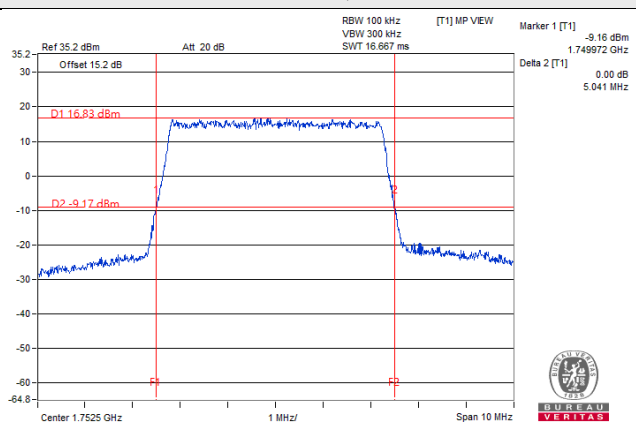

10MHz / 16QAM

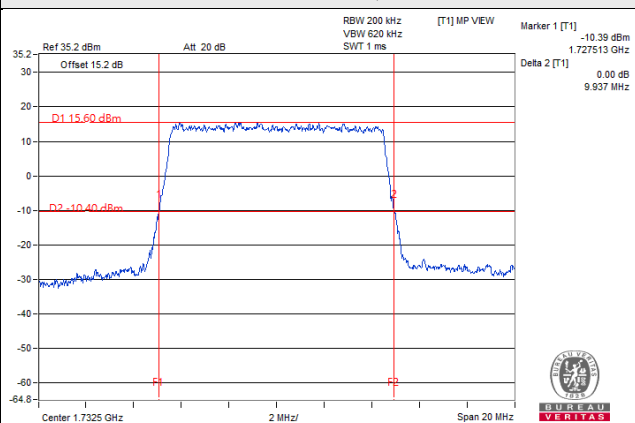

15MHz / 16QAM

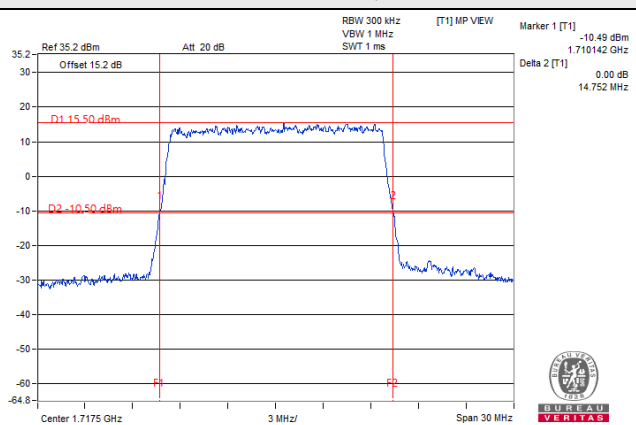

20MHz / QPSK

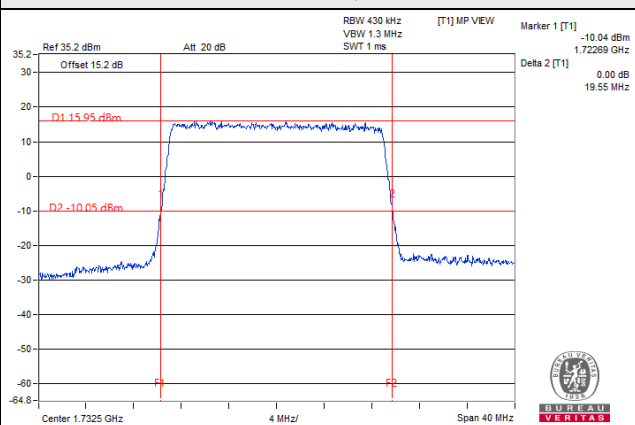

LTE Band 12							
Channel Bandwidth 1.4MHz				Channel Bandwidth 3MHz			
Channel	Frequency (MHz)	-26dB Bandwidth (MHz)		Channel	Frequency (MHz)	-26dB Bandwidth (MHz)	
		QPSK	16QAM			QPSK	16QAM
23017	699.7	1.29	1.28	23025	700.5	2.98	2.96
23095	707.5	1.29	1.28	23095	707.5	2.98	2.97
23173	715.3	1.30	1.29	23165	714.5	2.97	2.96
Channel Bandwidth 5MHz				Channel Bandwidth 10MHz			
Channel	Frequency (MHz)	-26dB Bandwidth (MHz)		Channel	Frequency (MHz)	-26dB Bandwidth (MHz)	
		QPSK	16QAM			QPSK	16QAM
23035	701.5	5.02	4.99	23060	704	9.86	9.91
23095	707.5	5.03	4.99	23095	707.5	9.91	9.95
23155	713.5	5.02	4.99	23130	711	9.85	9.90

Spectrum Plot of Worst Value

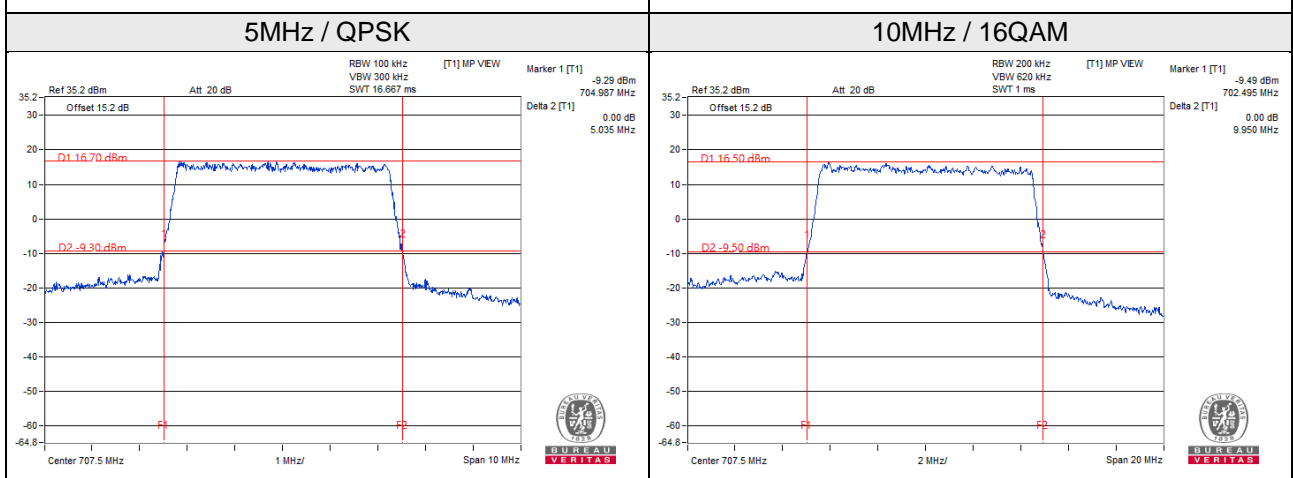
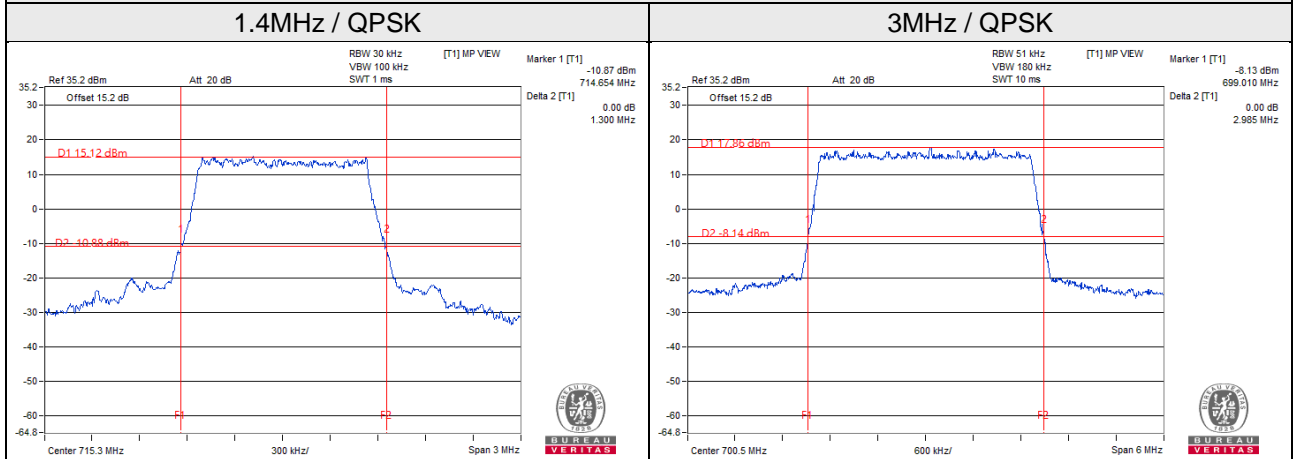

4.4.5 Test Results (Occupied Bandwidth)

LTE Band 4							
Channel Bandwidth 1.4MHz				Channel Bandwidth 3MHz			
Channel	Frequency (MHz)	Occupied Bandwidth (MHz)		Channel	Frequency (MHz)	Occupied Bandwidth (MHz)	
		QPSK	16QAM			QPSK	16QAM
19957	1710.7	1.08	1.09	19965	1711.5	2.70	2.68
20175	1732.5	1.08	1.09	20175	1732.5	2.69	2.68
20393	1754.3	1.09	1.10	20385	1753.5	2.70	2.68
Channel Bandwidth 5MHz				Channel Bandwidth 10MHz			
Channel	Frequency (MHz)	Occupied Bandwidth (MHz)		Channel	Frequency (MHz)	Occupied Bandwidth (MHz)	
		QPSK	16QAM			QPSK	16QAM
19975	1712.5	4.51	4.51	20000	1715	8.98	8.98
20175	1732.5	4.51	4.52	20175	1732.5	9.02	9.00
20375	1752.5	4.51	4.52	20350	1750	9.00	9.00
Channel Bandwidth 15MHz				Channel Bandwidth 20MHz			
Channel	Frequency (MHz)	Occupied Bandwidth (MHz)		Channel	Frequency (MHz)	Occupied Bandwidth (MHz)	
		QPSK	16QAM			QPSK	16QAM
20025	1717.5	13.47	13.44	20050	1720	17.96	17.88
20175	1732.5	13.50	13.50	20175	1732.5	18.04	17.92
20325	1747.5	13.50	13.47	20300	1745	18.04	17.96

Spectrum Plot of Worst Value

1.4MHz / 16QAM

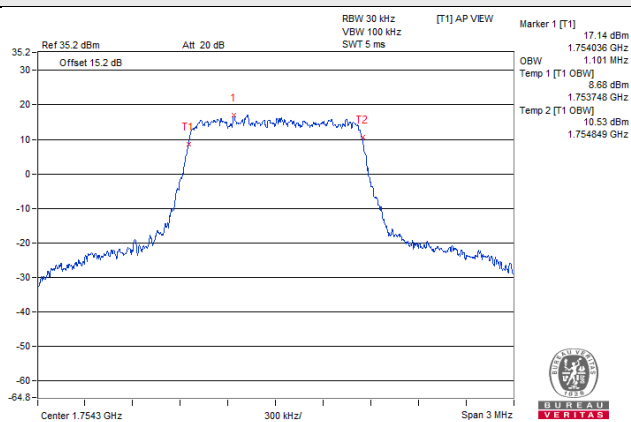

3MHz / QPSK

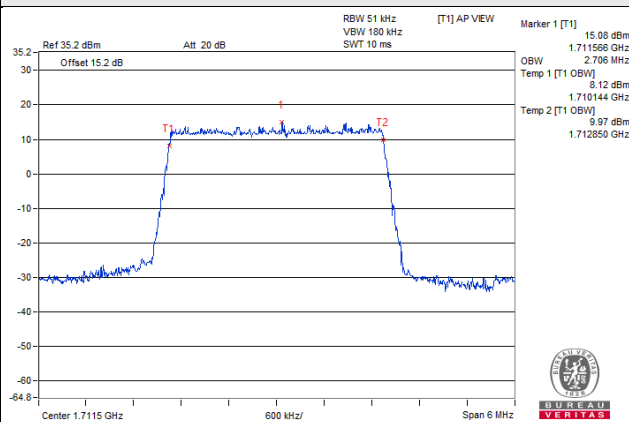

5MHz / 16QAM

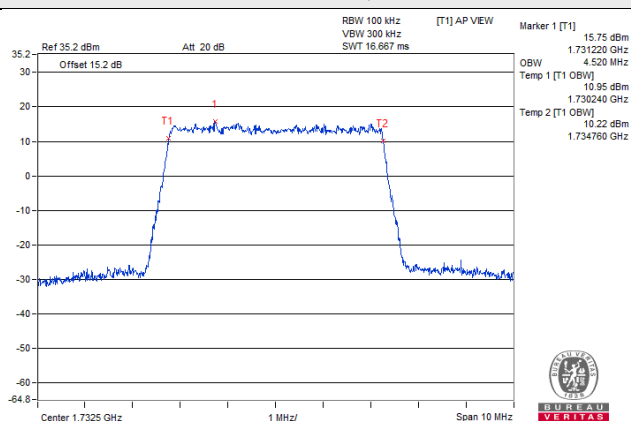

10MHz / QPSK

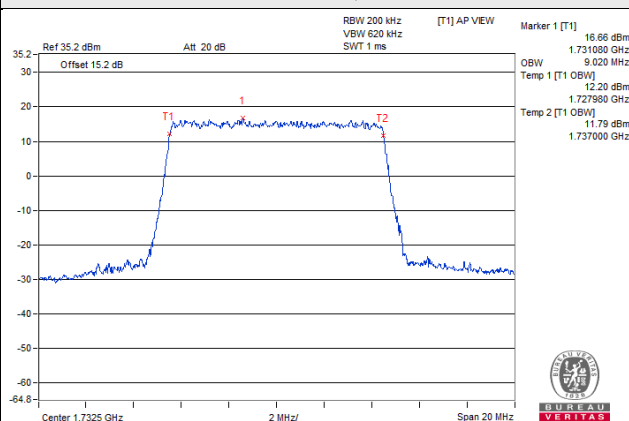

15MHz / QPSK

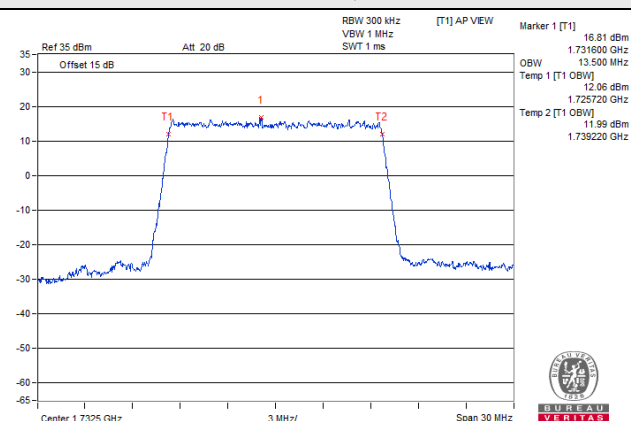

20MHz / QPSK

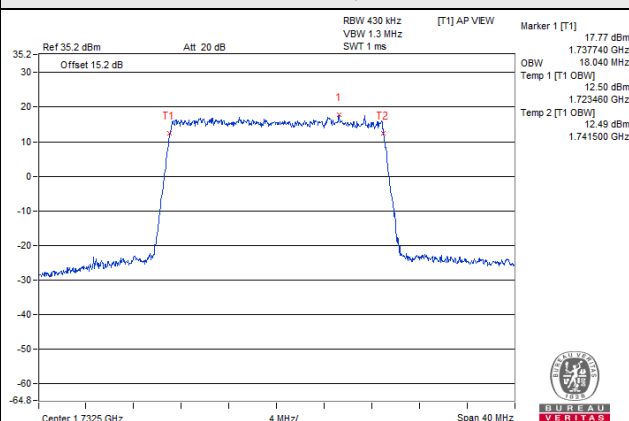

LTE Band 12							
Channel Bandwidth 1.4MHz				Channel Bandwidth 3MHz			
Channel	Frequency (MHz)	Occupied Bandwidth (MHz)		Channel	Frequency (MHz)	Occupied Bandwidth (MHz)	
		QPSK	16QAM			QPSK	16QAM
23017	699.7	1.09	1.10	23025	700.5	2.70	2.68
23095	707.5	1.09	1.10	23095	707.5	2.71	2.68
23173	715.3	1.09	1.10	23165	714.5	2.70	2.69
Channel Bandwidth 5MHz				Channel Bandwidth 10MHz			
Channel	Frequency (MHz)	Occupied Bandwidth (MHz)		Channel	Frequency (MHz)	Occupied Bandwidth (MHz)	
		QPSK	16QAM			QPSK	16QAM
23035	701.5	4.50	4.52	23060	704	9.00	9.00
23095	707.5	4.52	4.51	23095	707.5	9.02	9.00
23155	713.5	4.51	4.52	23130	711	8.98	8.98

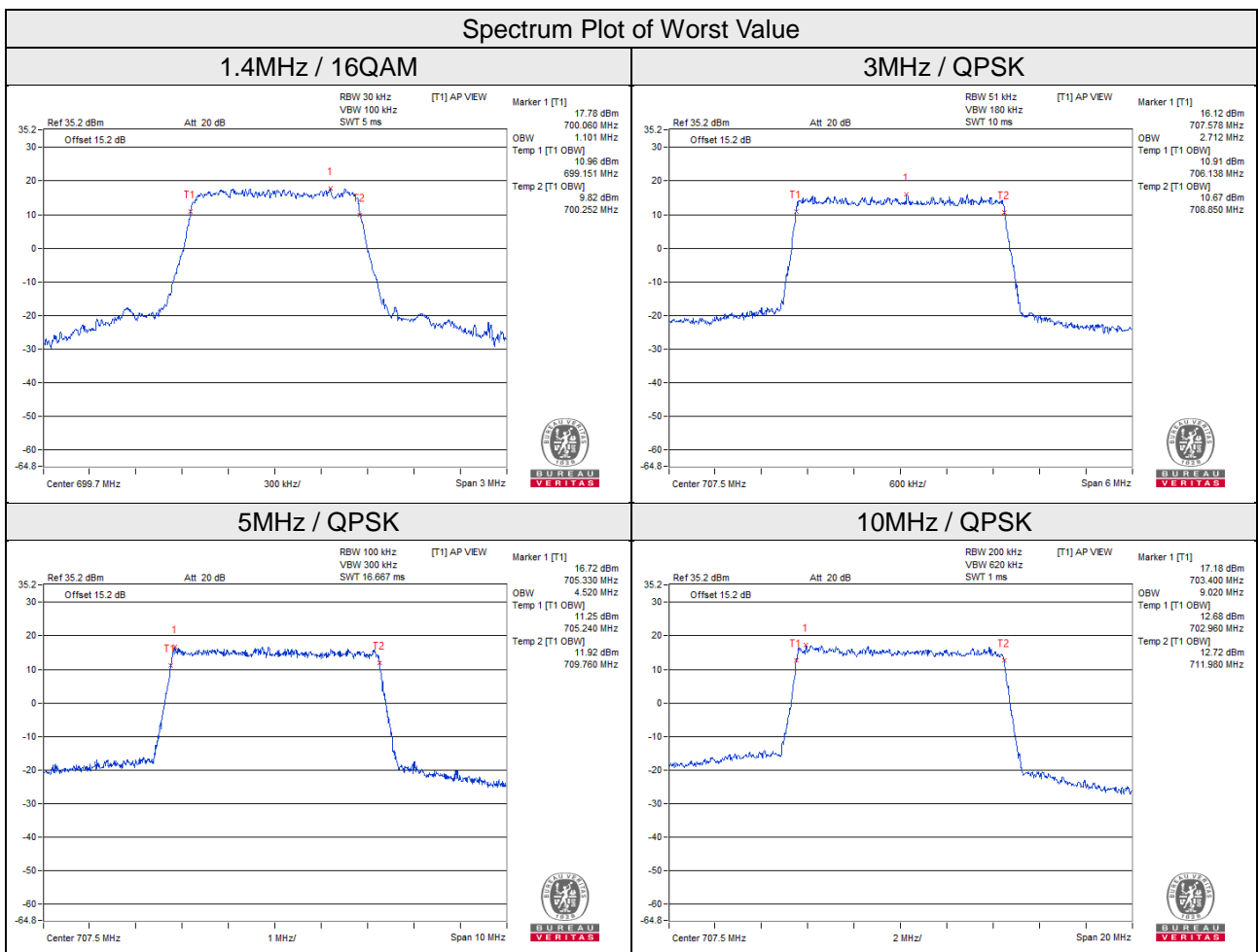

4.5 Channel Edge Measurement

4.5.1 Limits of Channel Edge Measurement

For Subpart L : LTE Band 4

According to FCC 27.53(h) AWS emission limits— General protection levels. Except as otherwise specified below, for operations in the 1695-1710 MHz, 1710-1755 MHz, 1755-1780 MHz, 1915-1920 MHz, 1995-2000 MHz, 2000-2020 MHz, 2110-2155 MHz, 2155-2180 MHz, and 2180-2200 bands, the power of any emission outside a licensee's frequency block shall be attenuated below the transmitter power (P) in watts by at least $43 + 10 \log_{10}(P)$ dB.

For Subpart H : LTE Band 12

According to FCC 27.53(g) For operations in the 600 MHz band and the 698-746 MHz band, the power of any emission outside a licensee's frequency band(s) of operation shall be attenuated below the transmitter power (P) within the licensed band(s) of operation, measured in watts, by at least $43 + 10 \log(P)$ dB. Compliance with this provision is based on the use of measurement instrumentation employing a resolution bandwidth of 100 kilohertz or greater. However, in the 100 kilohertz bands immediately outside and adjacent to a licensee's frequency block, a resolution bandwidth of at least 30 kHz may be employed.

4.5.2 Test Setup

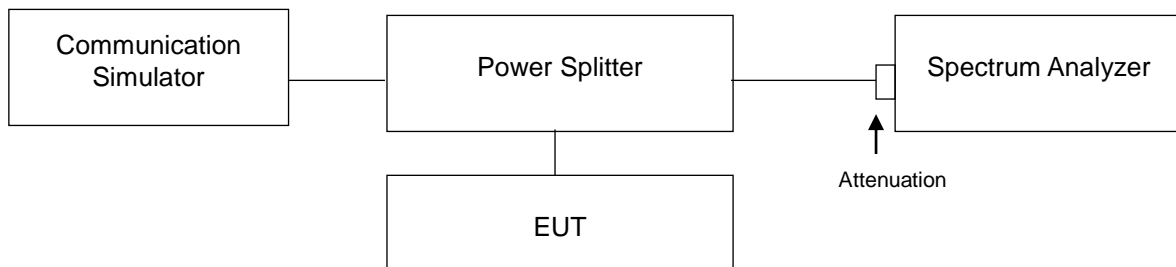

4.5.3 Test Procedures

- a. All measurements were done at low and high operational frequency range.
- b. The center frequency of spectrum is the band edge frequency and s RB of the spectrum is >1% emission bandwidth and VB of the spectrum is $\geq 3 \cdot RB$.
- c. Record the max trace plot into the test report.

4.5.4 Test Results

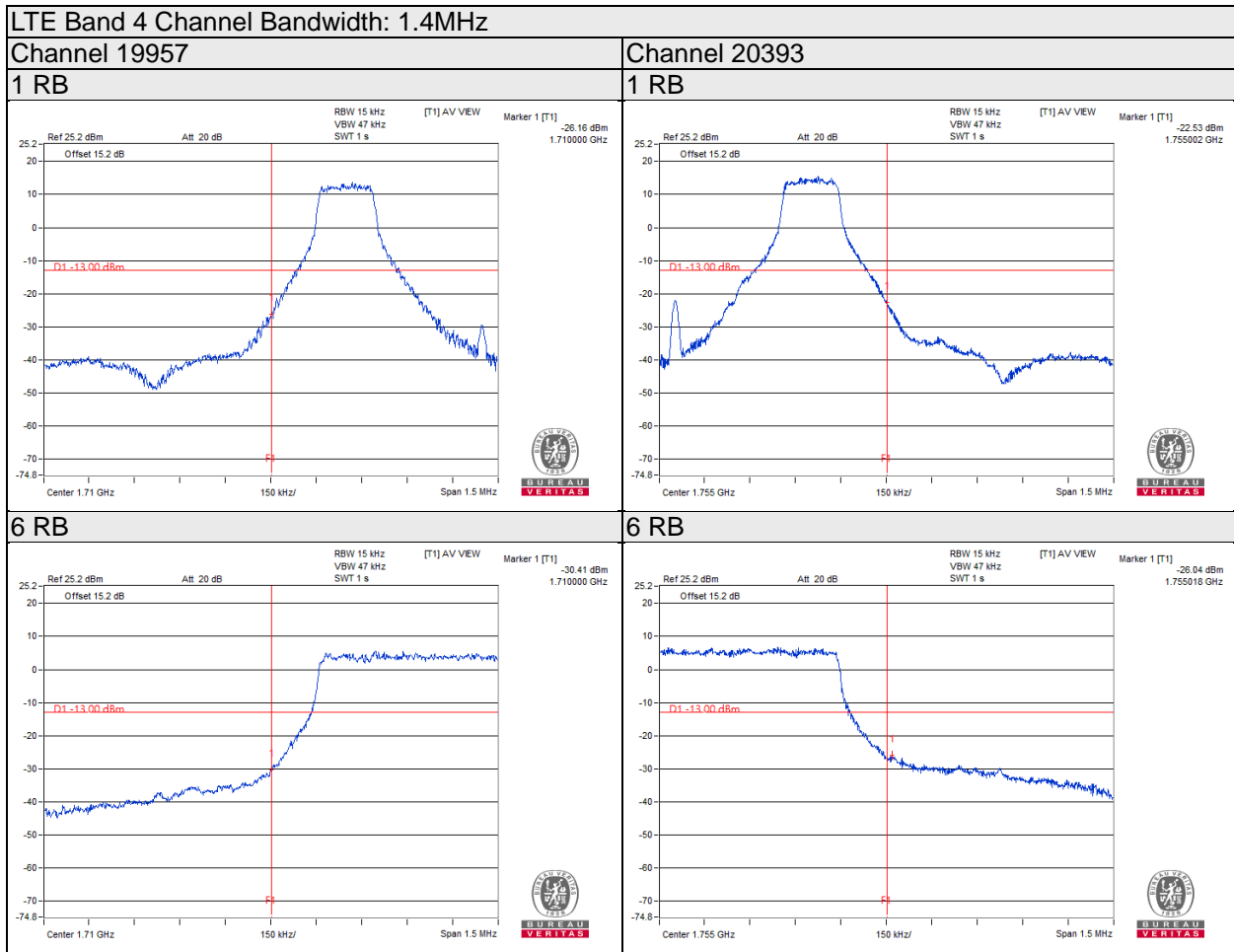

LTE Band 4 Channel Bandwidth: 3MHz

Channel 19965

1 RB

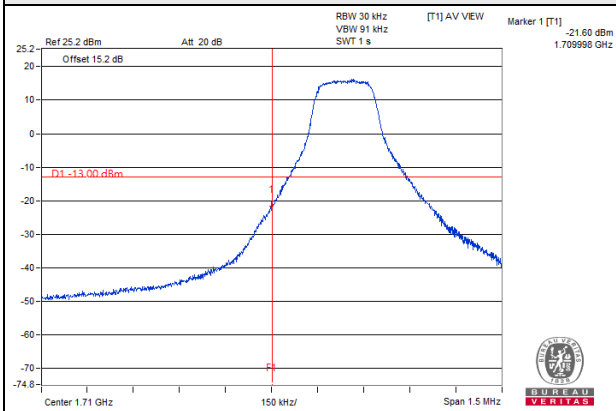

Channel 20385

1 RB

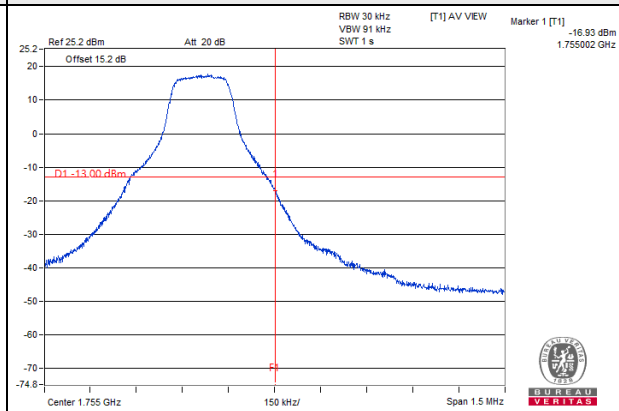

15 RB

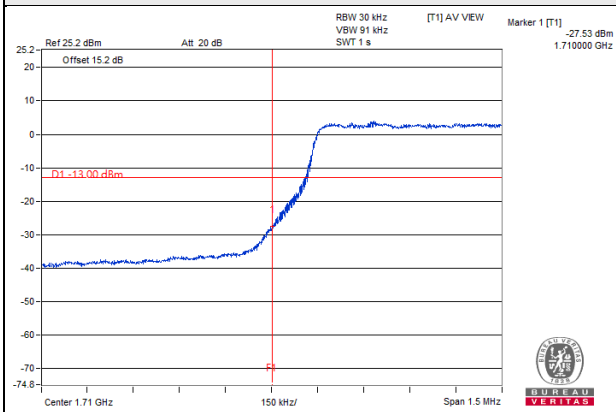

15 RB

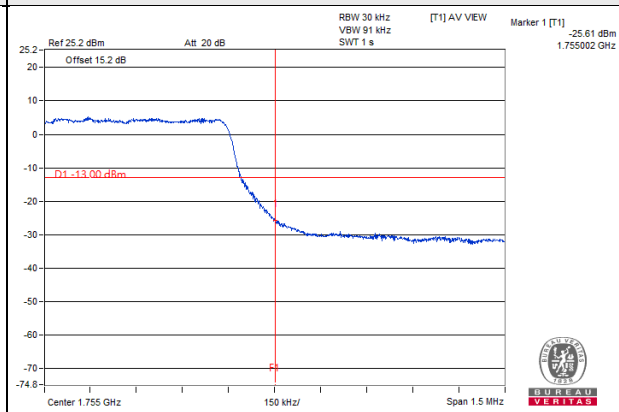

LTE Band 4 Channel Bandwidth: 5MHz

Channel 19975

1 RB

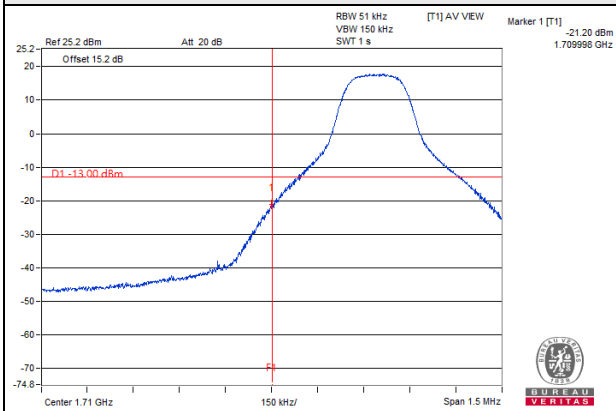

Channel 20375

1 RB

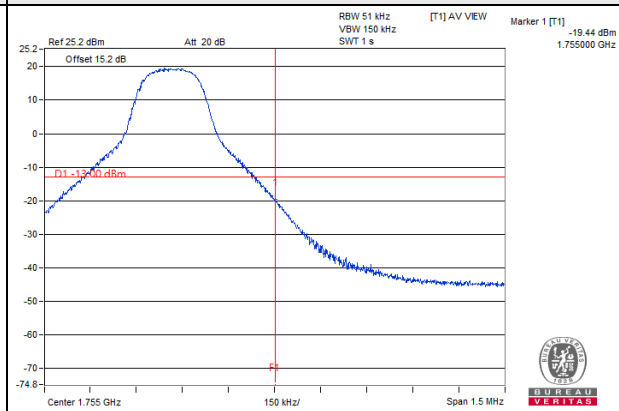

25 RB

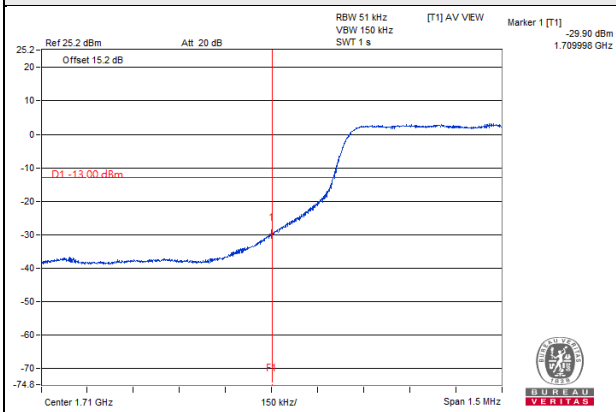

25 RB

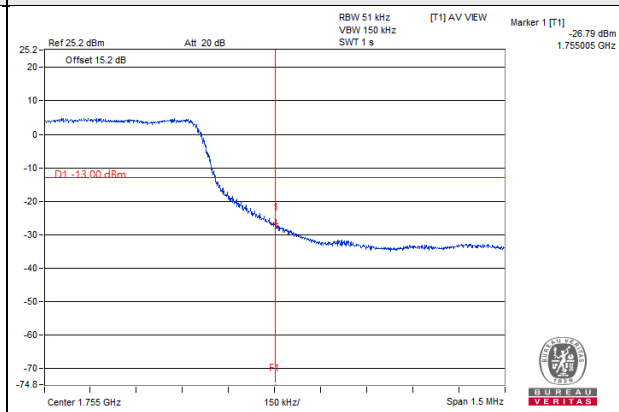

LTE Band 4 Channel Bandwidth: 10MHz

Channel 20000

1 RB

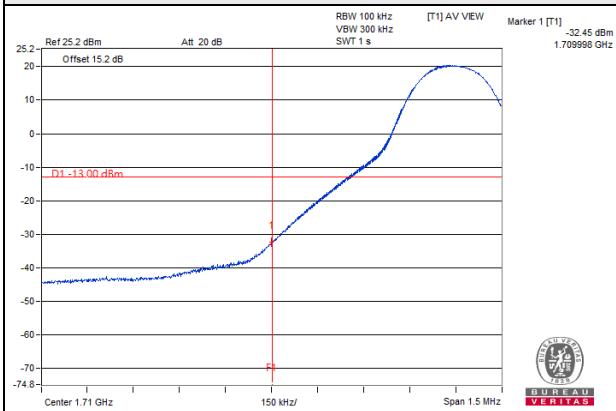

Channel 20350

1 RB

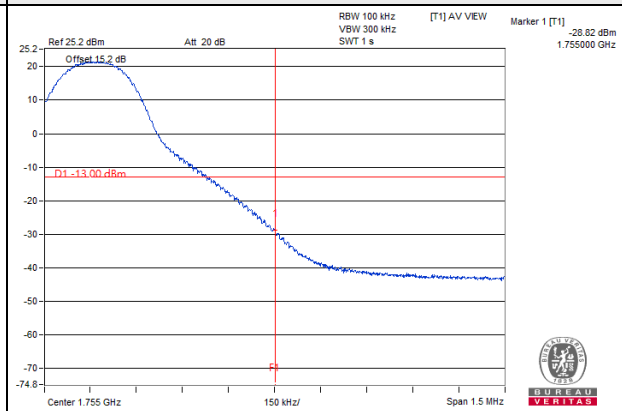

50 RB

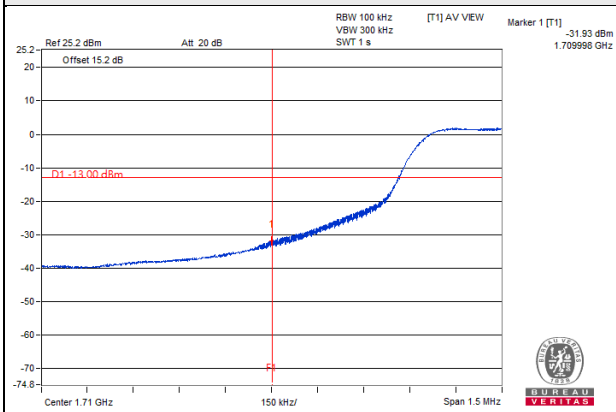

50 RB

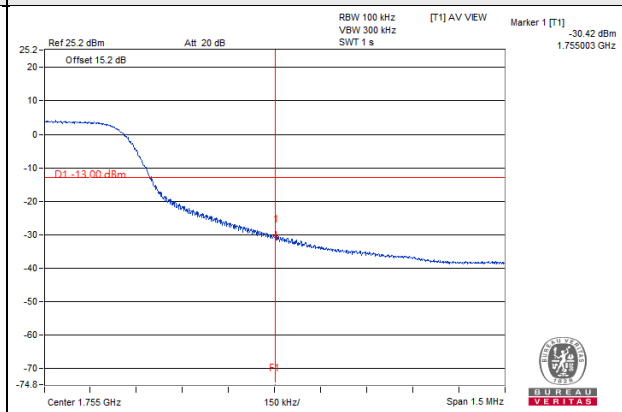

LTE Band 4 Channel Bandwidth: 15MHz

Channel 20025

1 RB

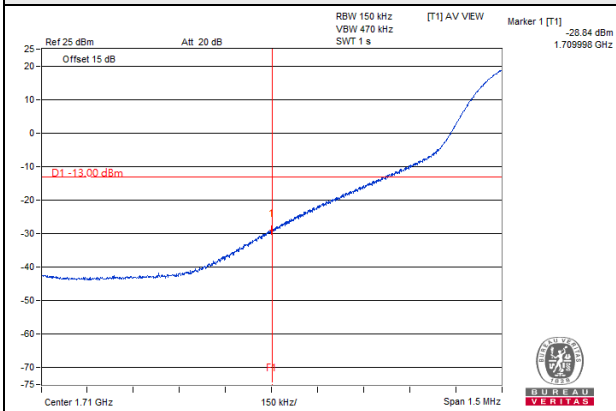

Channel 20325

1 RB

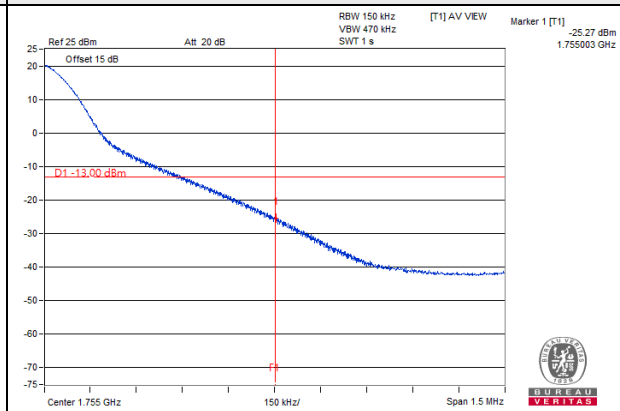

75 RB

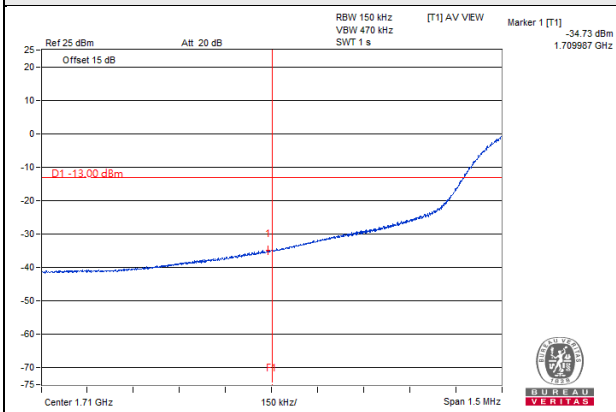

75 RB

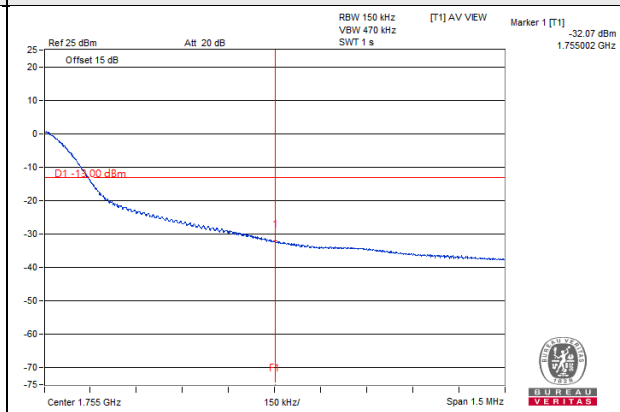

LTE Band 4 Channel Bandwidth: 20MHz

Channel 20050

1 RB

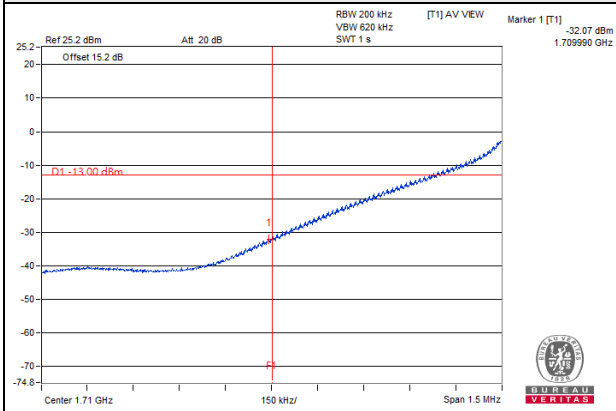

Channel 20300

1 RB

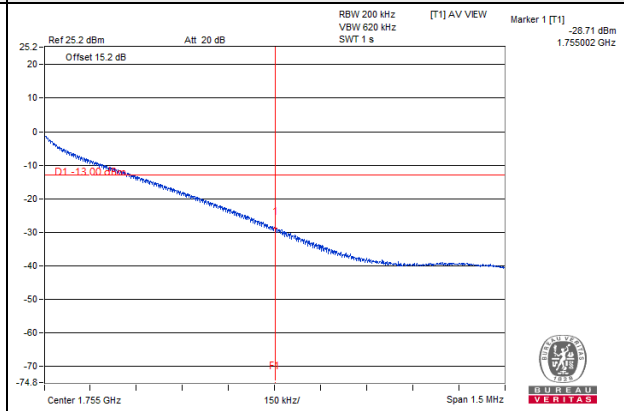

100 RB

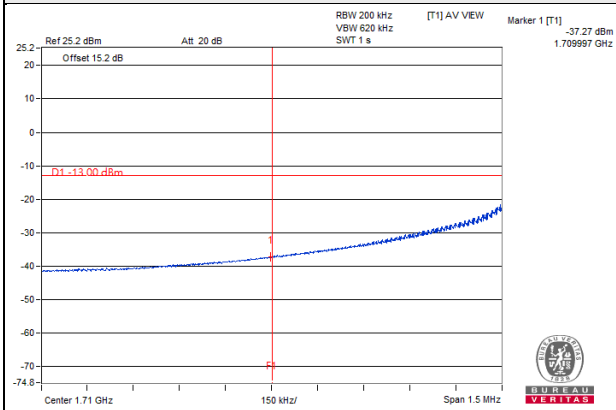

100 RB

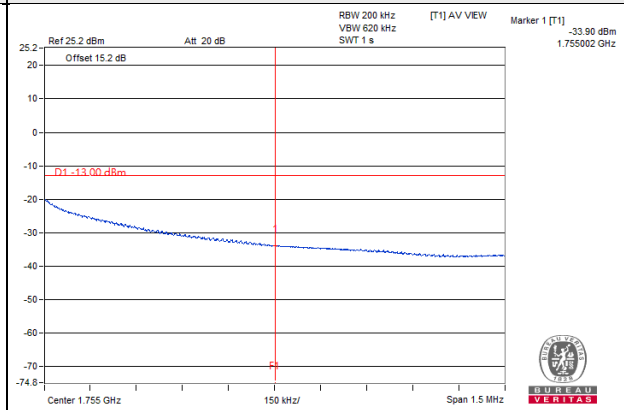

LTE Band 12 Channel Bandwidth: 1.4MHz

Channel 23017

1 RB

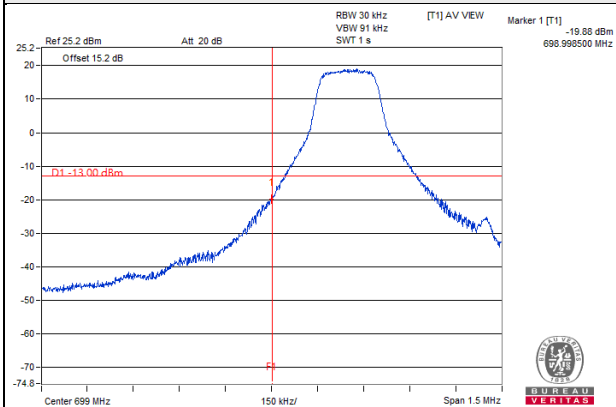

Channel 23173

1 RB

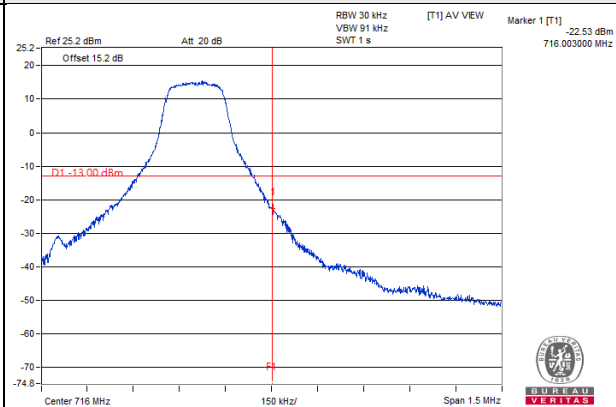

6 RB

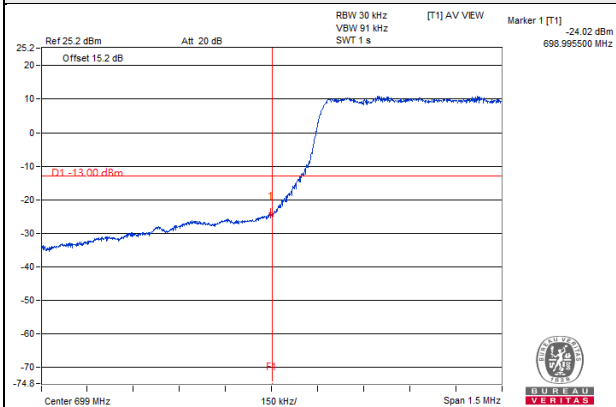

6 RB

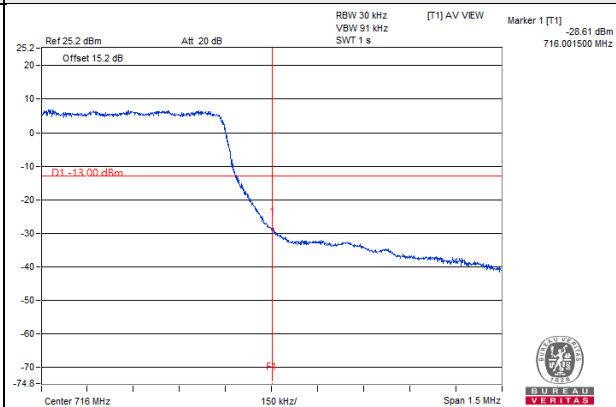

LTE Band 12 Channel Bandwidth: 3MHz

Channel 23025

1 RB

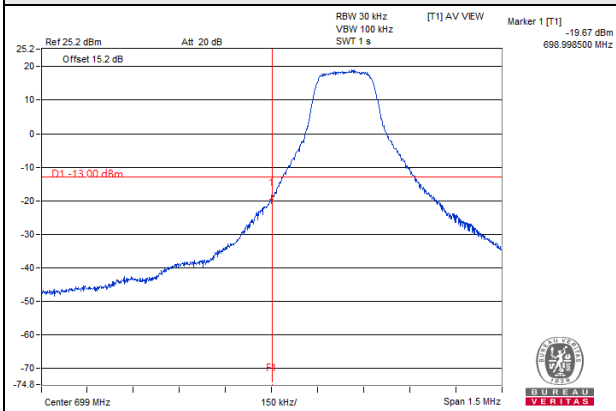

Channel 23165

1 RB

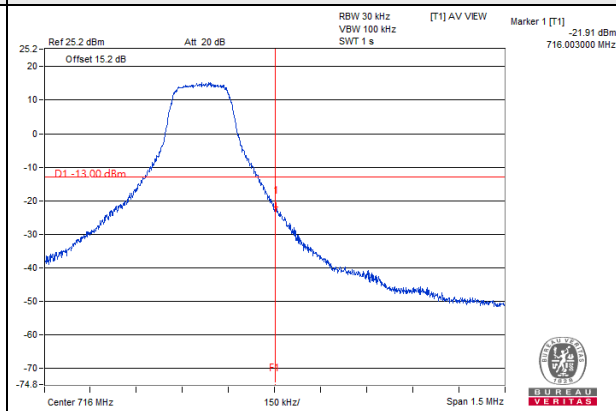

15 RB

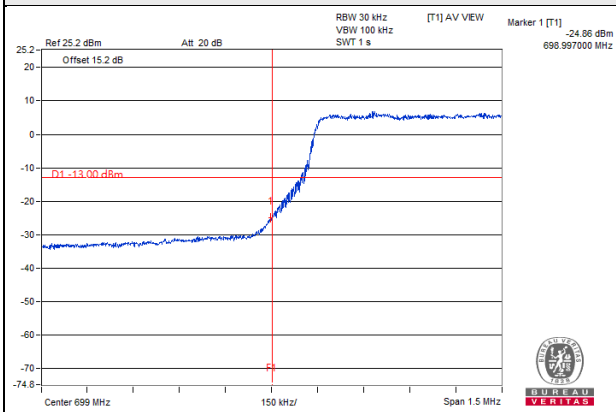

15 RB

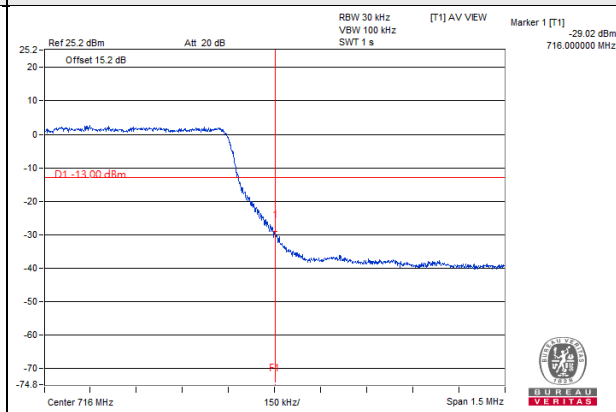

LTE Band 12 Channel Bandwidth: 5MHz

Channel 23035

1 RB

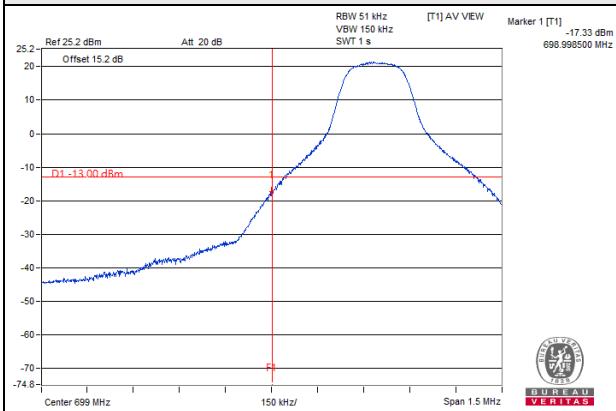

Channel 23155

1 RB

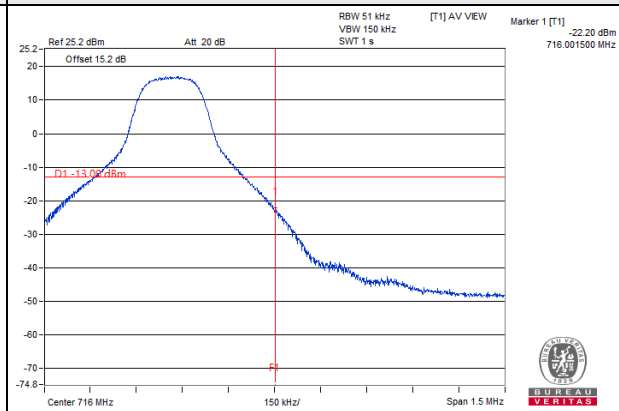

25 RB

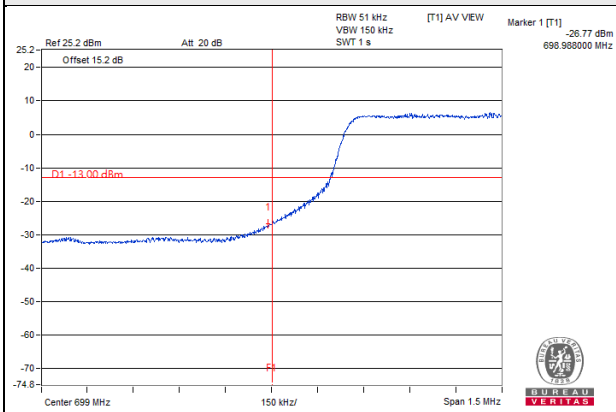

25 RB

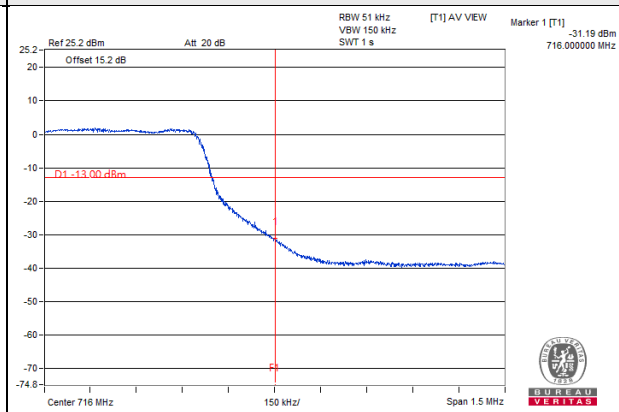

LTE Band 12 Channel Bandwidth: 10MHz

Channel 23060

1 RB

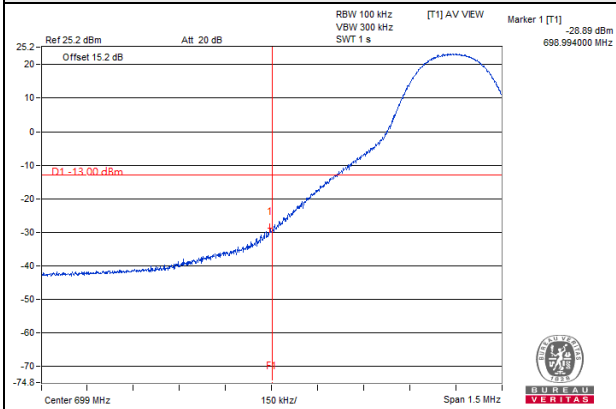

Channel 23130

1 RB

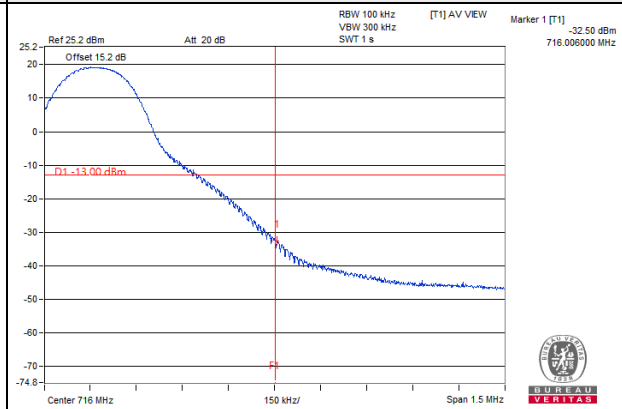

50 RB

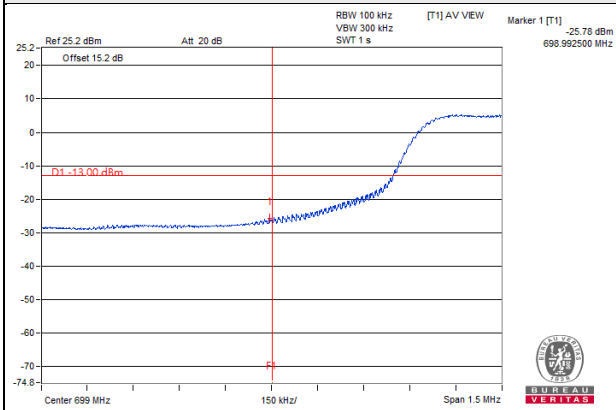

50 RB

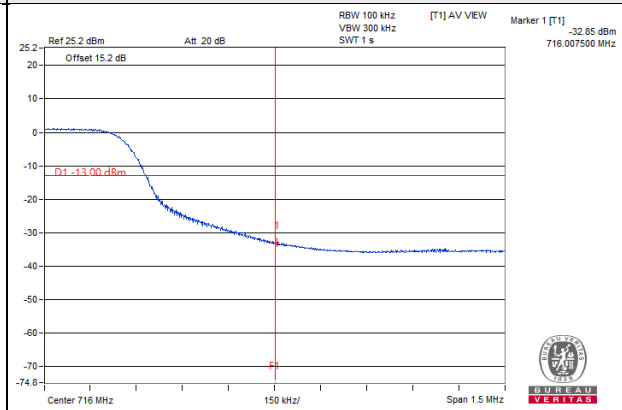

4.6 Peak to Average Ratio

4.6.1 Limits of Peak to Average Ratio Measurement

In measuring transmissions in this band using an average power technique, the peak to-average ratio (PAR) of the transmission may not exceed 13 dB

4.6.2 Test Setup

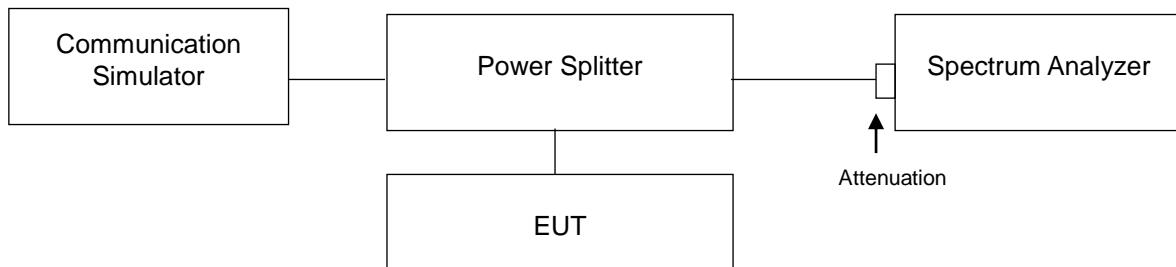

4.6.3 Test Procedures

1. Set resolution/measurement bandwidth \geq signal's occupied bandwidth;
2. Set the number of counts to a value that stabilizes the measured CCDF curve;
3. Record the maximum PAPR level associated with a probability of 0.1%.

4.6.4 Test Results

LTE Band 4							
Channel Bandwidth 1.4MHz				Channel Bandwidth 3MHz			
Channel	Frequency (MHz)	Peak To Average Ratio (dB)		Channel	Frequency (MHz)	Peak To Average Ratio (dB)	
		QPSK	16QAM			QPSK	16QAM
19957	1710.7	5.25	5.98	19965	1711.5	5.21	6.06
20175	1732.5	5.02	5.82	20175	1732.5	4.99	5.85
20393	1754.3	4.62	5.21	20385	1753.5	4.56	5.45
Channel Bandwidth 5MHz				Channel Bandwidth 10MHz			
Channel	Frequency (MHz)	Peak To Average Ratio (dB)		Channel	Frequency (MHz)	Peak To Average Ratio (dB)	
		QPSK	16QAM			QPSK	16QAM
19975	1712.5	5.24	6.09	20000	1715	5.18	6.01
20175	1732.5	5.12	5.96	20175	1732.5	5.1	5.93
20375	1752.5	4.92	5.79	20350	1750	5.03	5.91
Channel Bandwidth 15MHz				Channel Bandwidth 20MHz			
Channel	Frequency (MHz)	Peak To Average Ratio (dB)		Channel	Frequency (MHz)	Peak To Average Ratio (dB)	
		QPSK	16QAM			QPSK	16QAM
20025	1717.5	5.35	6.00	20050	1720	5.07	5.86
20175	1732.5	5.3	5.97	20175	1732.5	5.11	5.87
20325	1747.5	5.31	5.99	20300	1745	5.19	5.96

Spectrum Plot of Worst Value

1.4MHz / 16QAM

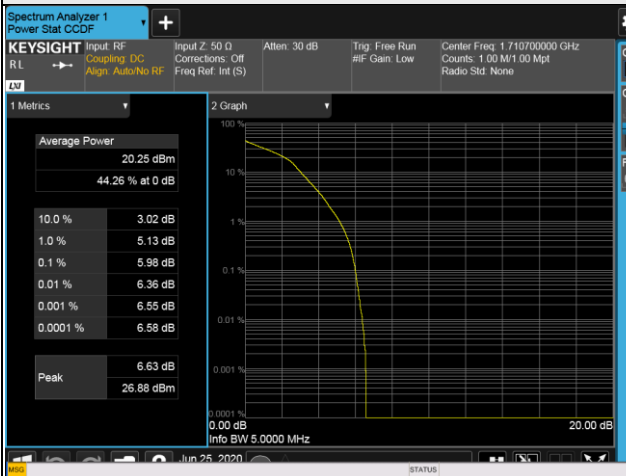

3MHz / 16QAM

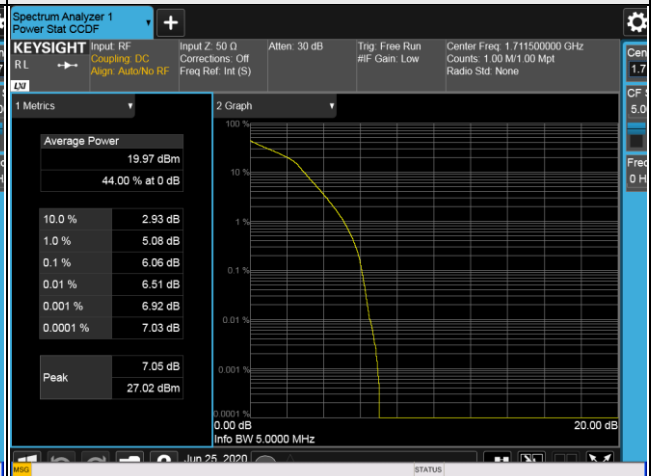

5MHz / 16QAM

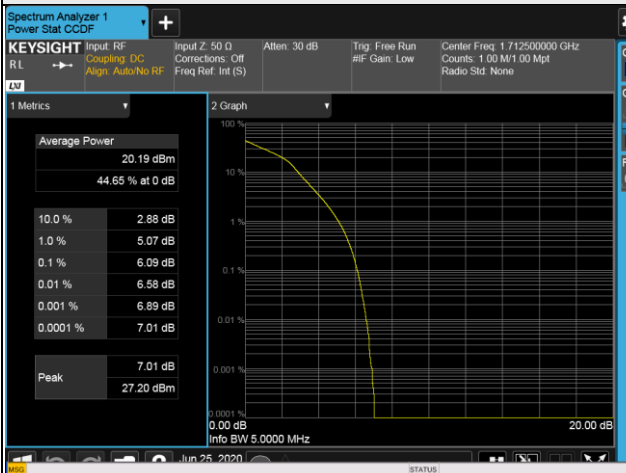

10MHz / 16QAM

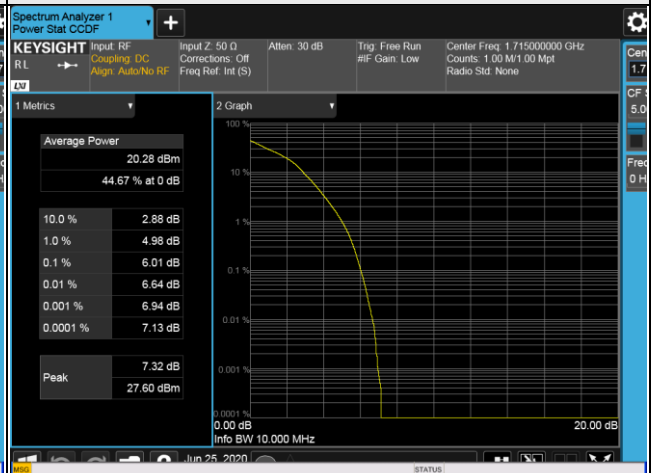

15MHz / 16QAM

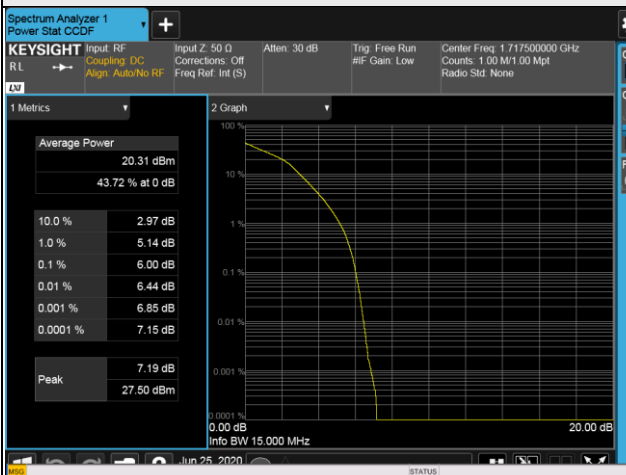

20MHz / 16QAM

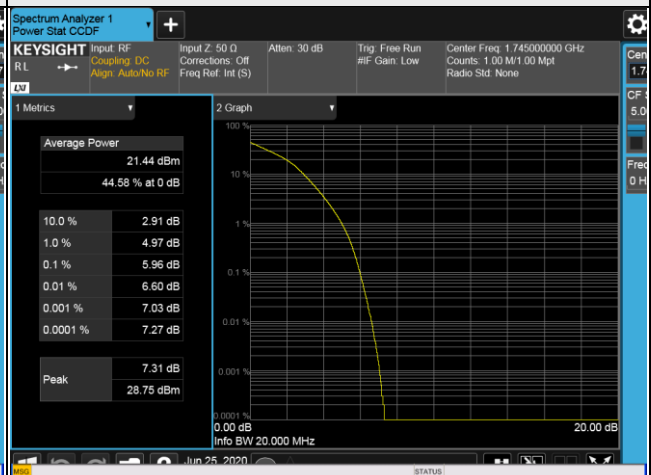

LTE Band 12							
Channel Bandwidth 1.4MHz				Channel Bandwidth 3MHz			
Channel	Frequency (MHz)	Peak To Average Ratio (dB)		Channel	Frequency (MHz)	Peak To Average Ratio (dB)	
		QPSK	16QAM			QPSK	16QAM
23017	699.7	5.77	6.36	23025	700.5	5.55	6.43
23095	707.5	5.75	6.54	23095	707.5	5.77	6.64
23173	715.3	5.35	6.21	23165	714.5	5.41	6.27
Channel Bandwidth 5MHz				Channel Bandwidth 10MHz			
Channel	Frequency (MHz)	Peak To Average Ratio (dB)		Channel	Frequency (MHz)	Peak To Average Ratio (dB)	
		QPSK	16QAM			QPSK	16QAM
23035	701.5	5.52	6.37	23060	704	5.58	6.42
23095	707.5	5.68	6.53	23095	707.5	5.59	6.45
23155	713.5	5.4	6.28	23130	711	5.41	6.32



4.7 Conducted Spurious Emissions

4.7.1 Limits of Conducted Spurious Emissions Measurement

According to FCC 27.53(g) For operations in the 600 MHz band and the 698-746 MHz band, the power of any emission outside a licensee's frequency band(s) of operation shall be attenuated below the transmitter power (P) within the licensed band(s) of operation, measured in watts, by at least $43 + 10 \log (P)$ dB. Compliance with this provision is based on the use of measurement instrumentation employing a resolution bandwidth of 100 kilohertz or greater. However, in the 100 kilohertz bands immediately outside and adjacent to a licensee's frequency block, a resolution bandwidth of at least 30 kHz may be employed.

According to FCC 27.53(h) AWS emission limits— General protection levels. Except as otherwise specified below, for operations in the 1695-1710 MHz, 1710-1755 MHz, 1755-1780 MHz, 1915-1920 MHz, 1995-2000 MHz, 2000-2020 MHz, 2110-2155 MHz, 2155-2180 MHz, and 2180-2200 bands, the power of any emission outside a licensee's frequency block shall be attenuated below the transmitter power (P) in watts by at least $43 + 10 \log_{10} (P)$ dB.

4.7.2 Test Setup

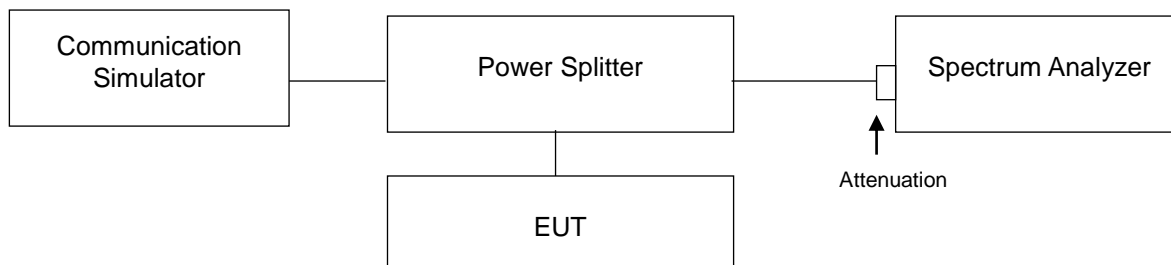

4.7.3 Test Procedure

- a. All measurements were done at 3 channels: low, middle and high operational frequency range.
- b. When the spectrum scanned from 9 kHz to the tenth harmonic of the highest fundamental frequency, it shall be connected to the 20dB pad attenuated the carried frequency.

4.7.4 Test Results

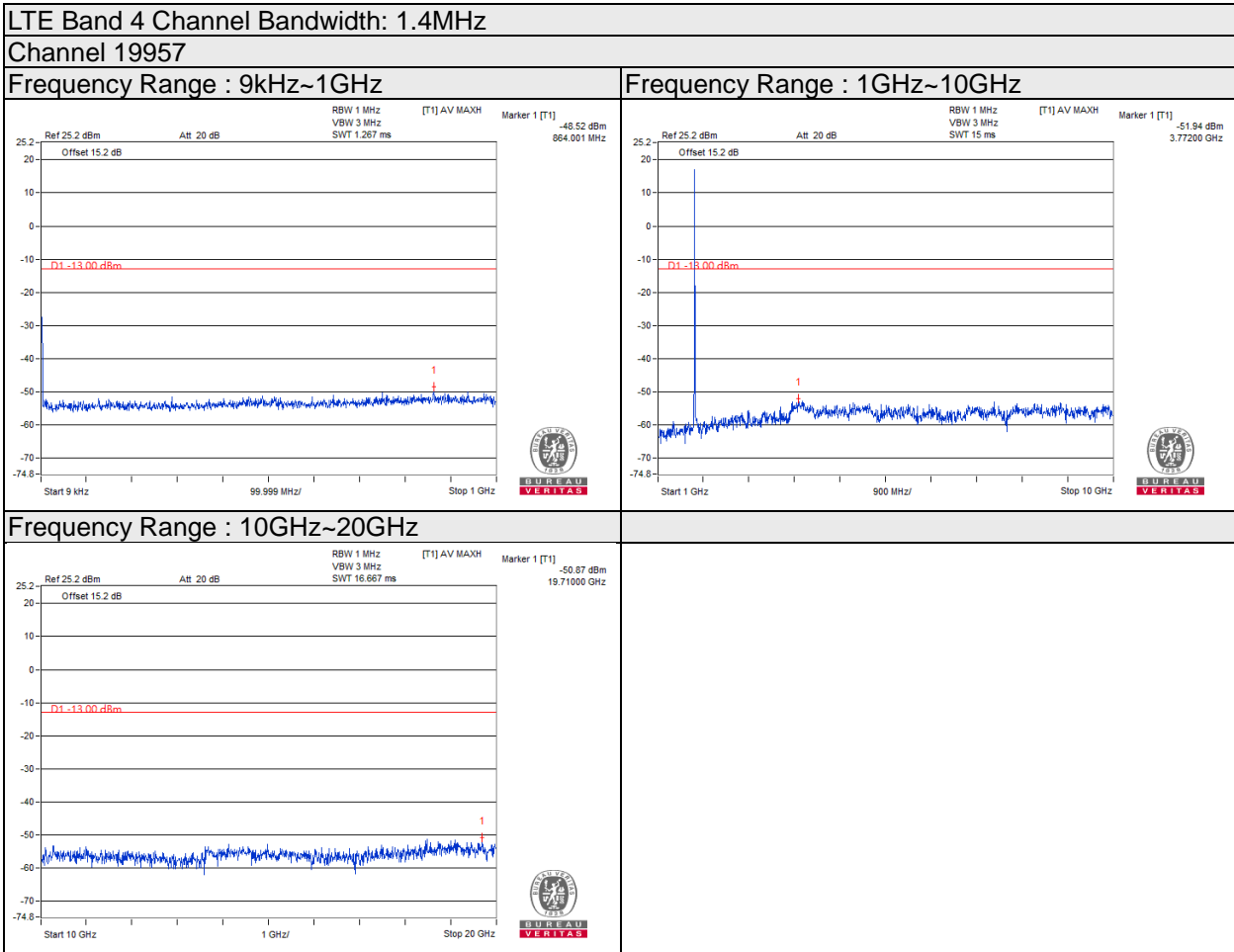

Note: The signal of 9kHz is IF signal from test instrument.

LTE Band 4 Channel Bandwidth: 1.4MHz

Channel 20175

Frequency Range : 9kHz~1GHz

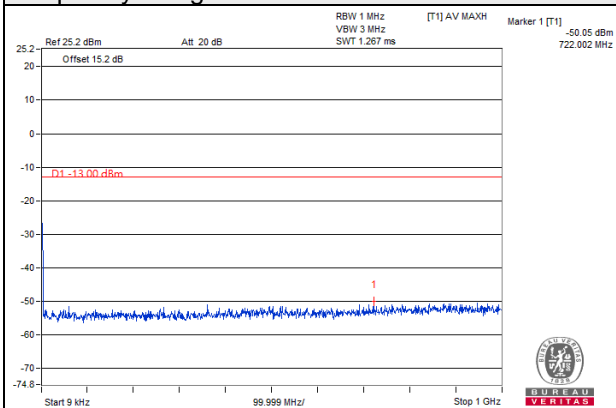

Frequency Range : 1GHz~10GHz

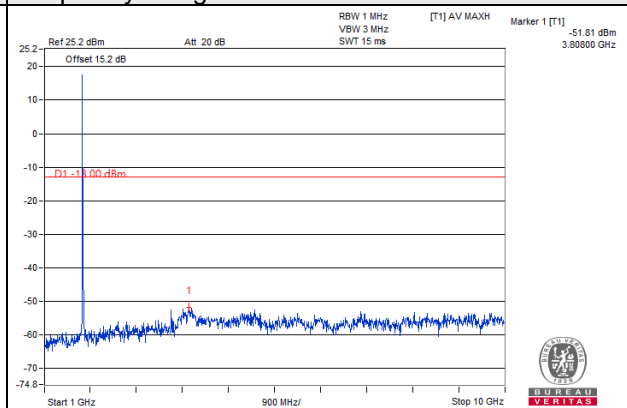

Frequency Range : 10GHz~20GHz

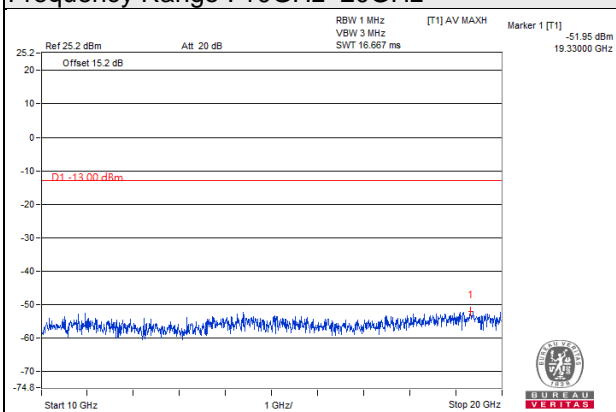

Note: The signal of 9kHz is IF signal from test instrument.

LTE Band 4 Channel Bandwidth: 1.4MHz

Channel 20393

Frequency Range : 9kHz~1GHz

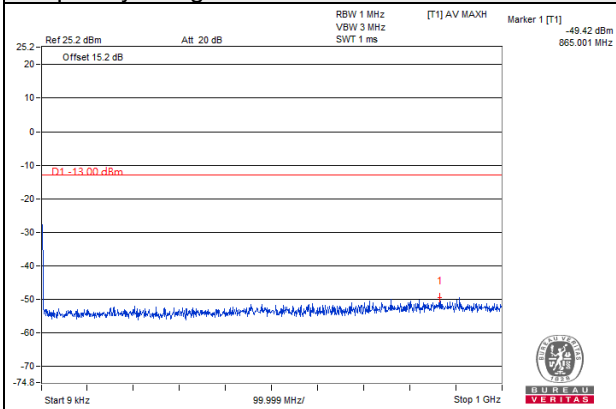

Frequency Range : 1GHz~10GHz

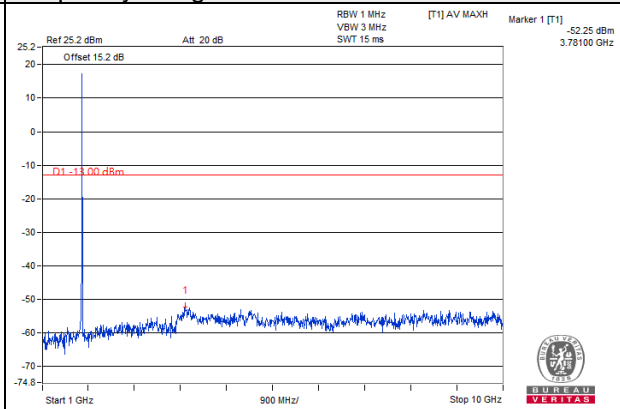

Frequency Range : 10GHz~20GHz

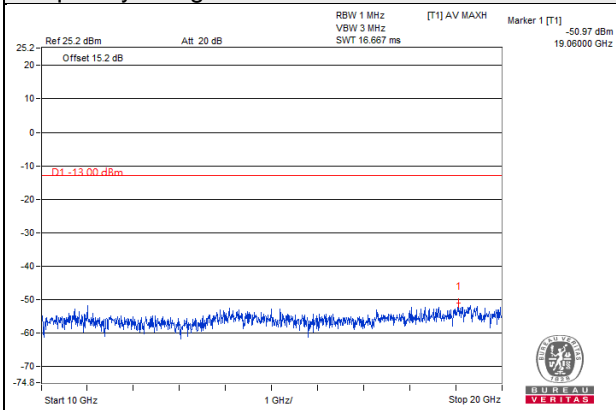

Note: The signal of 9kHz is IF signal from test instrument.

LTE Band 4 Channel Bandwidth: 3MHz

Channel 19965

Frequency Range : 9kHz~1GHz

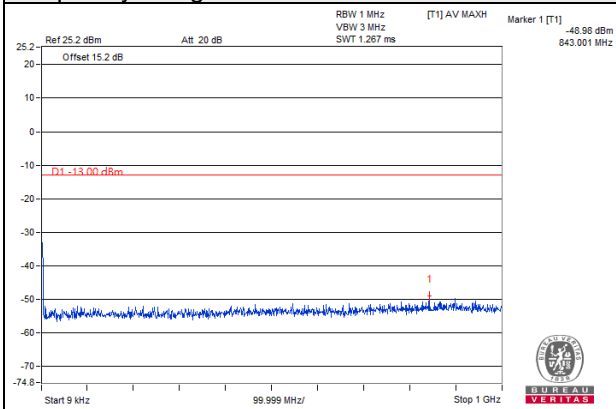

Frequency Range : 1GHz~10GHz

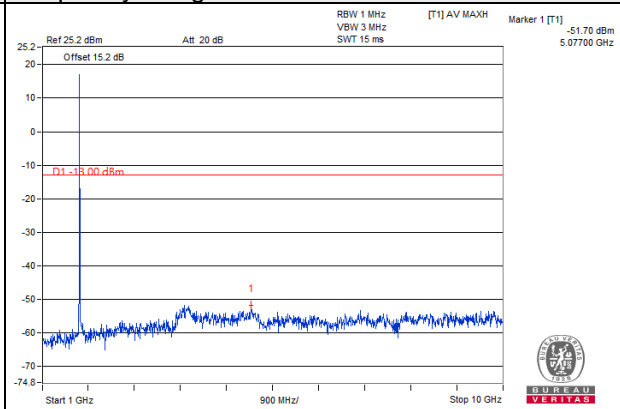

Frequency Range : 10GHz~20GHz

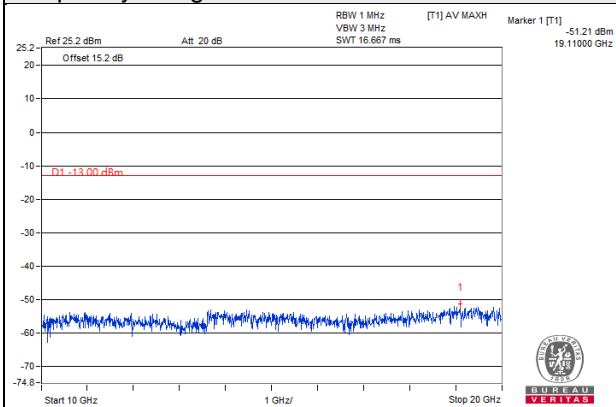

Note: The signal of 9kHz is IF signal from test instrument.

LTE Band 4 Channel Bandwidth: 3MHz

Channel 20175

Frequency Range : 9kHz~1GHz

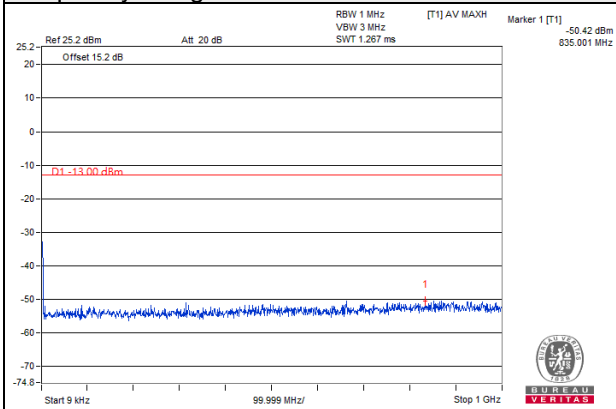

Frequency Range : 1GHz~10GHz

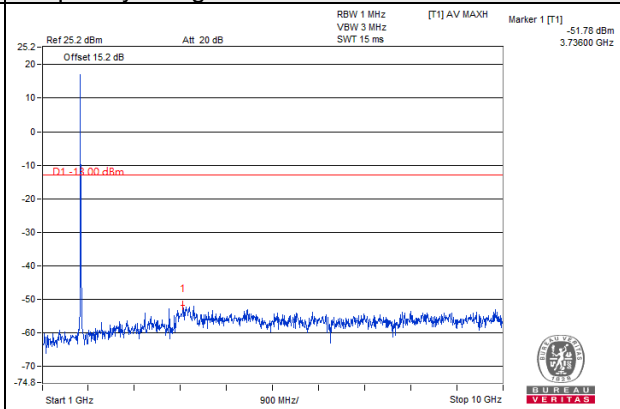

Frequency Range : 10GHz~20GHz

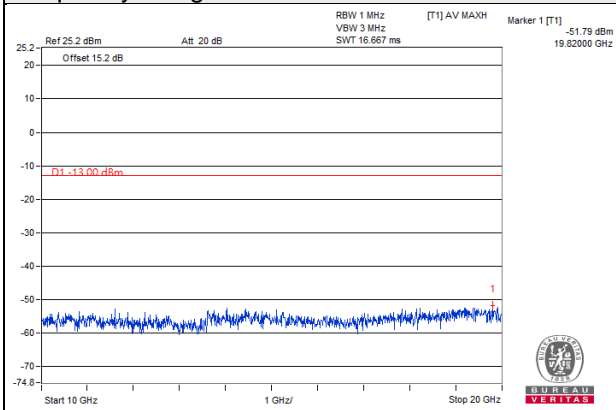

Note: The signal of 9kHz is IF signal from test instrument.

LTE Band 4 Channel Bandwidth: 3MHz

Channel 20385

Frequency Range : 9kHz~1GHz

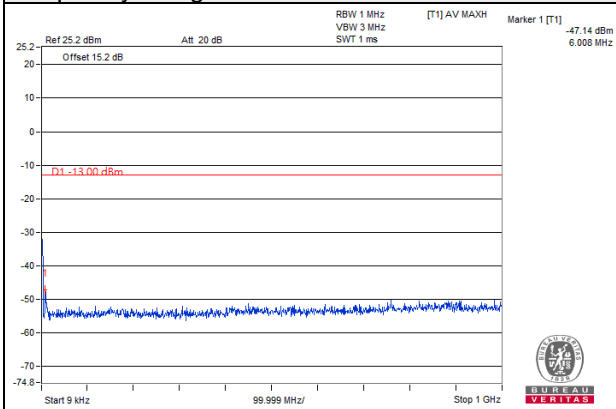

Frequency Range : 1GHz~10GHz

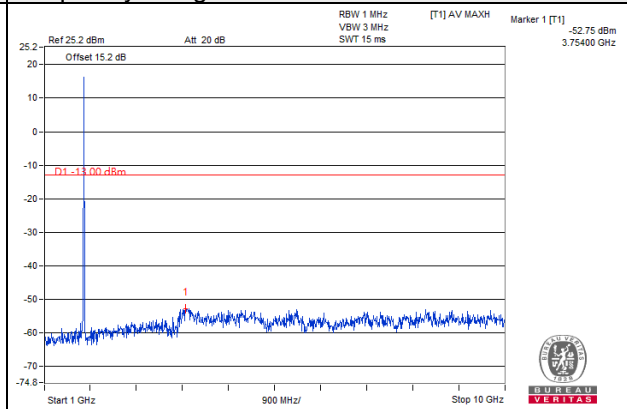

Frequency Range : 10GHz~20GHz

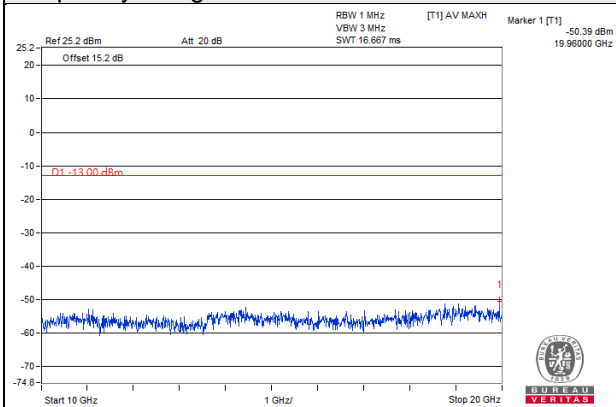

Note: The signal of 9kHz is IF signal from test instrument.

LTE Band 4 Channel Bandwidth: 5MHz

Channel 19975

Frequency Range : 9kHz~1GHz

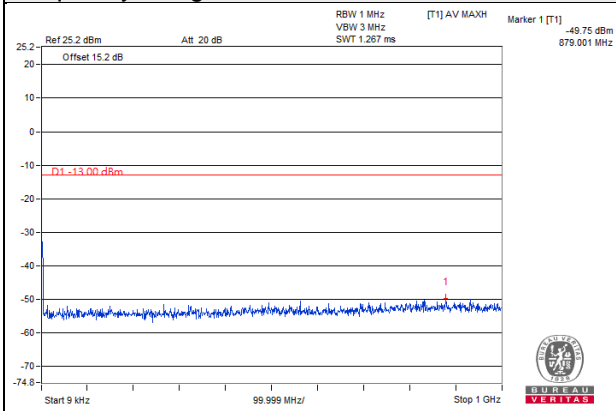

Frequency Range : 1GHz~10GHz

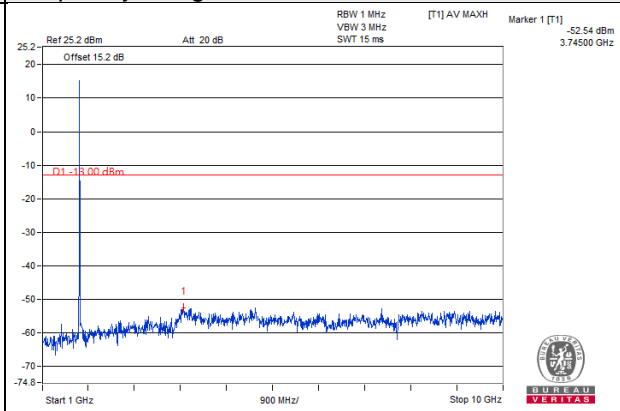

Frequency Range : 10GHz~20GHz

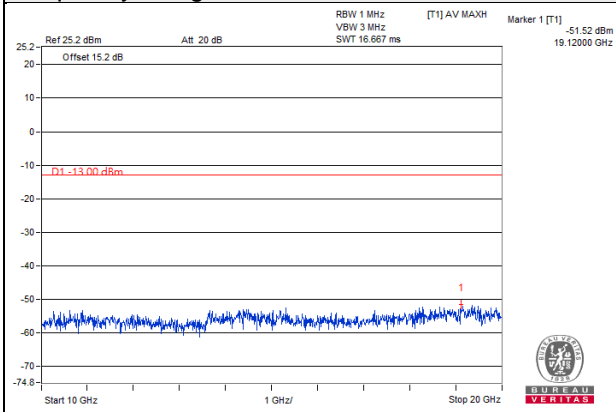

Note: The signal of 9kHz is IF signal from test instrument.

LTE Band 4 Channel Bandwidth: 5MHz

Channel 20175

Frequency Range : 9kHz~1GHz

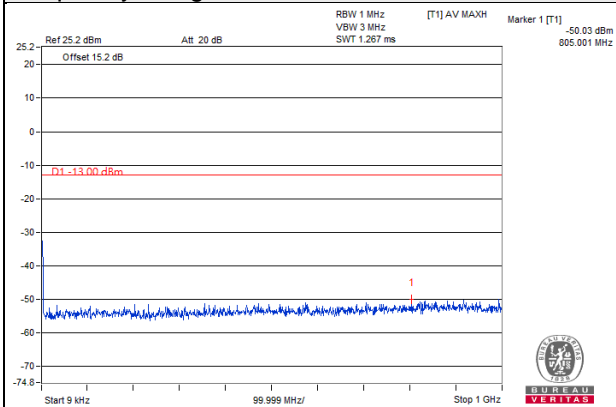

Frequency Range : 1GHz~10GHz

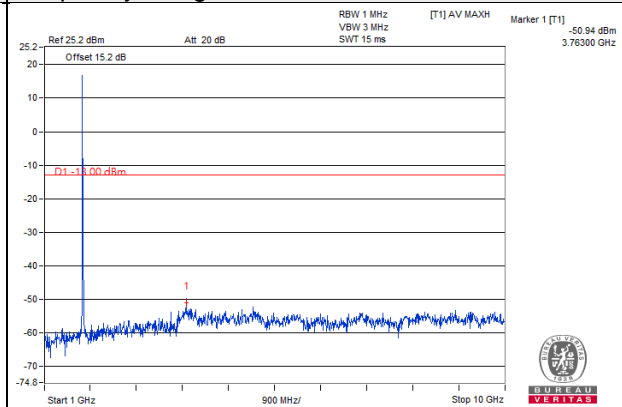

Frequency Range : 10GHz~20GHz

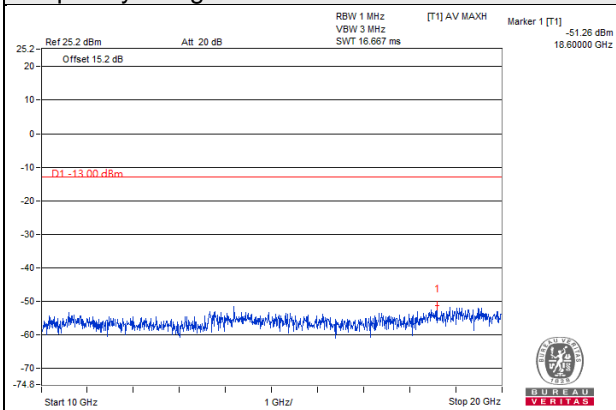

Note: The signal of 9kHz is IF signal from test instrument.

LTE Band 4 Channel Bandwidth: 5MHz

Channel 20375

Frequency Range : 9kHz~1GHz

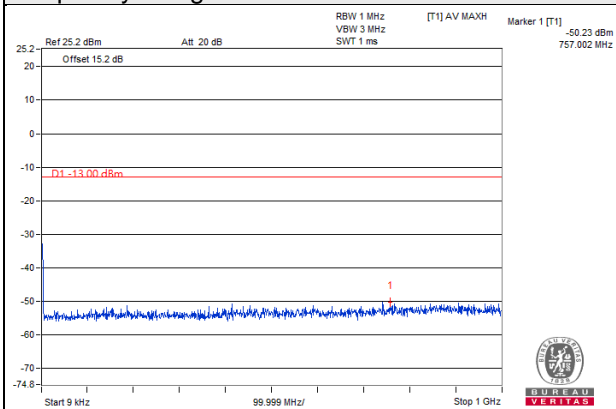

Frequency Range : 1GHz~10GHz

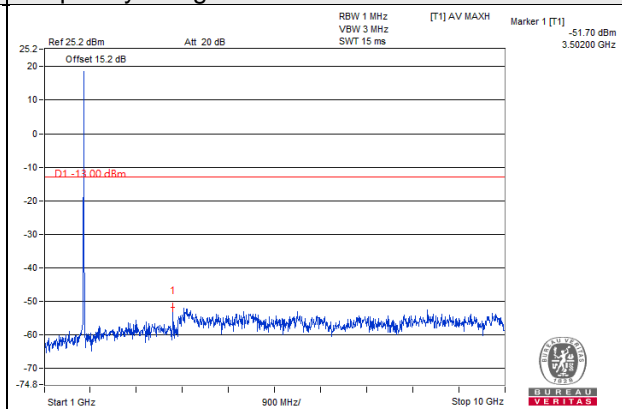

Frequency Range : 10GHz~20GHz

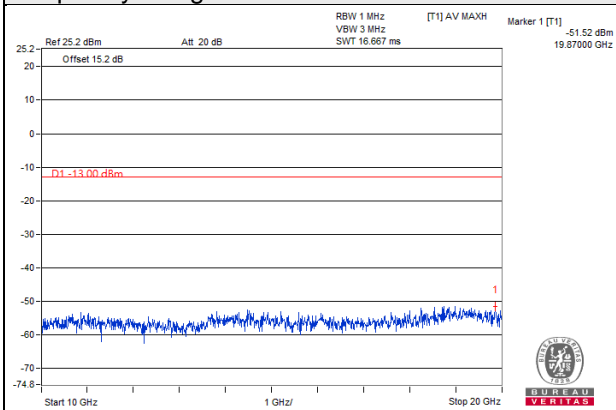

Note: The signal of 9kHz is IF signal from test instrument.

LTE Band 4 Channel Bandwidth: 10MHz

Channel 20000

Frequency Range : 9kHz~1GHz

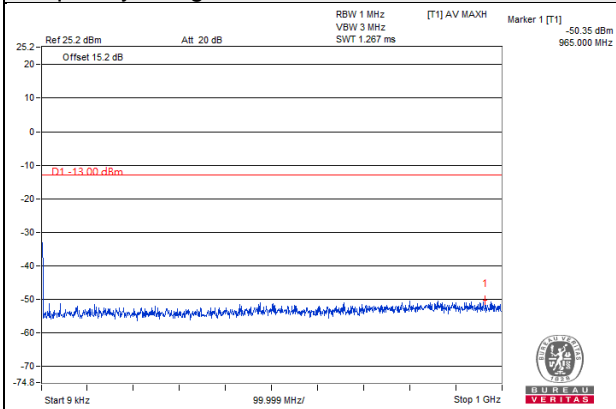

Frequency Range : 1GHz~10GHz

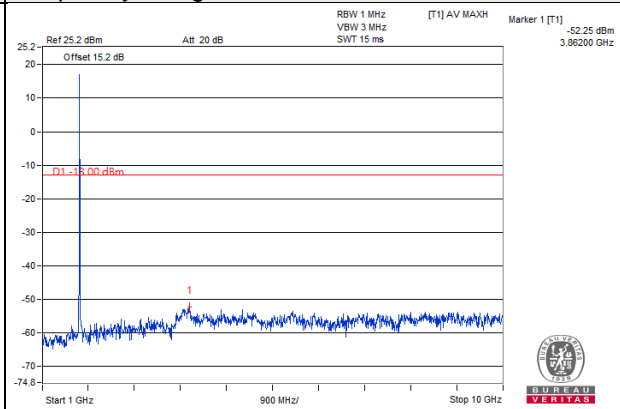

Frequency Range : 10GHz~20GHz

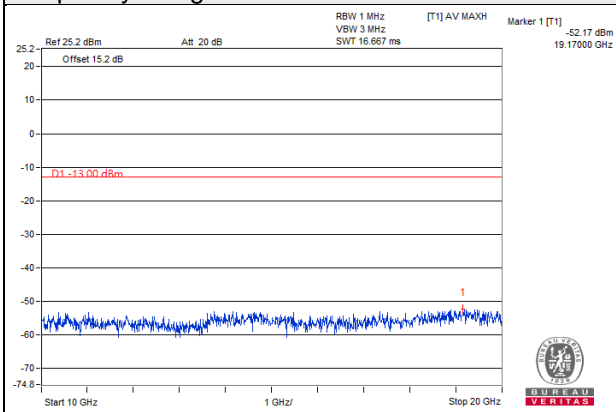

Note: The signal of 9kHz is IF signal from test instrument.

LTE Band 4 Channel Bandwidth: 10MHz

Channel 20175

Frequency Range : 9kHz~1GHz

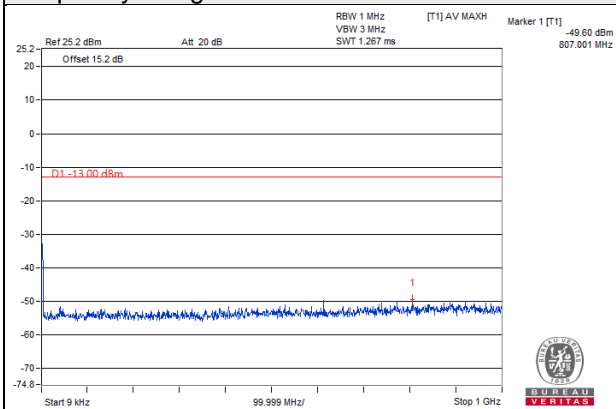

Frequency Range : 1GHz~10GHz

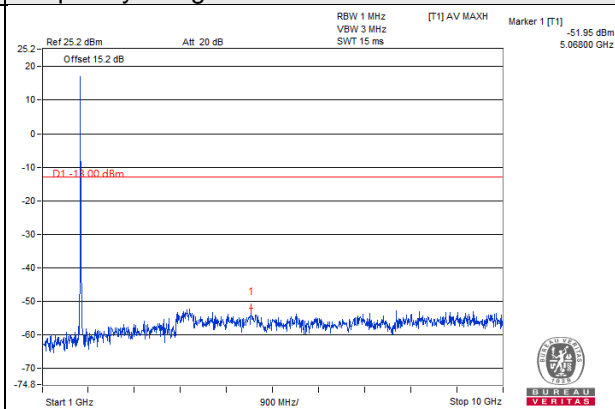

Frequency Range : 10GHz~20GHz

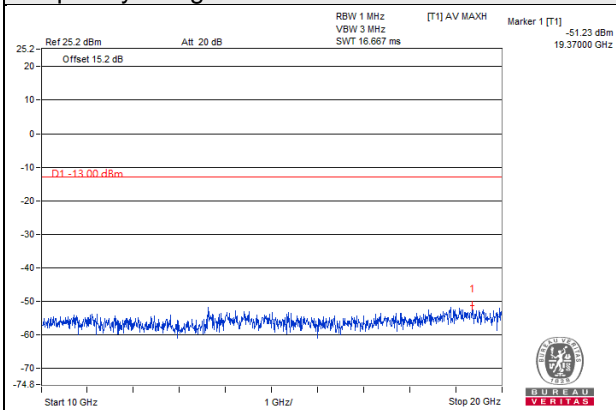

Note: The signal of 9kHz is IF signal from test instrument.

LTE Band 4 Channel Bandwidth: 10MHz

Channel 20350

Frequency Range : 9kHz~1GHz

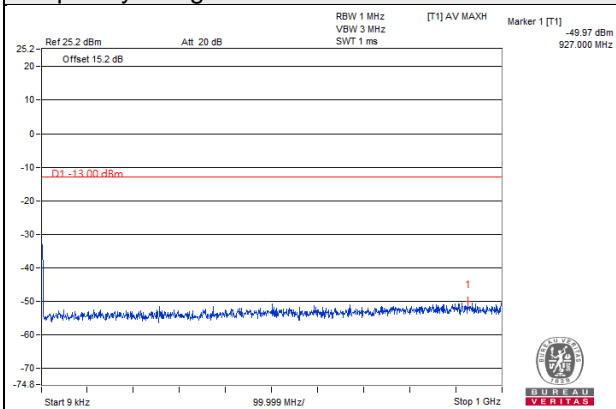

Frequency Range : 1GHz~10GHz

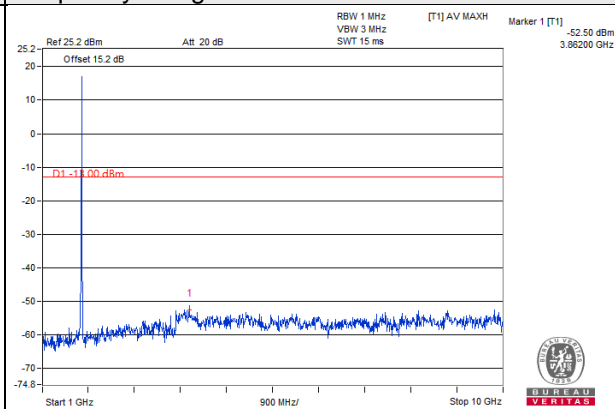

Frequency Range : 10GHz~20GHz

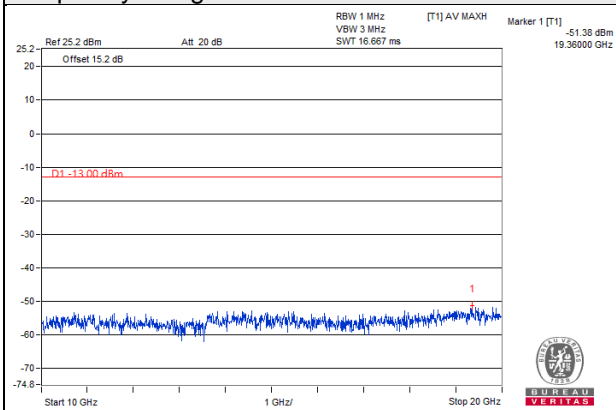

Note: The signal of 9kHz is IF signal from test instrument.

LTE Band 4 Channel Bandwidth: 15MHz

Channel 20025

Frequency Range : 9kHz~1GHz

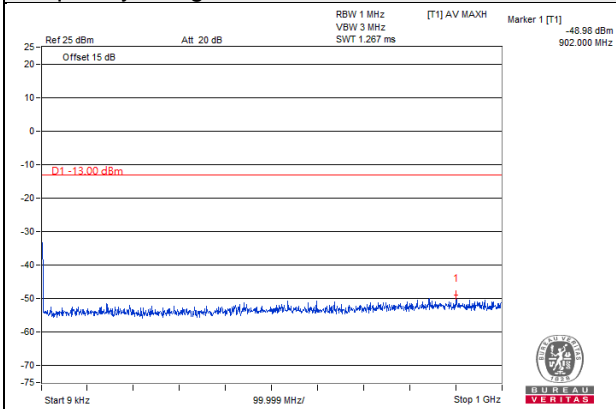

Frequency Range : 1GHz~10GHz

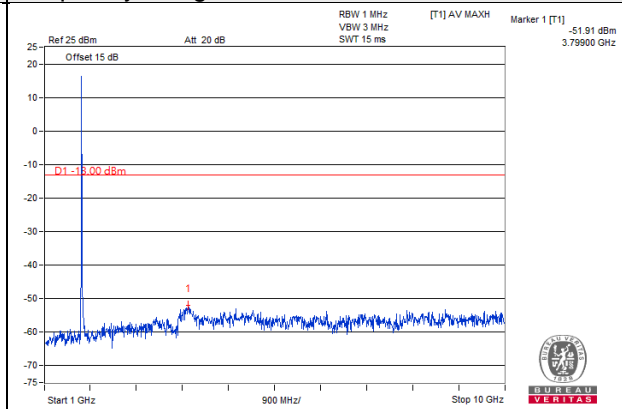

Frequency Range : 10GHz~20GHz

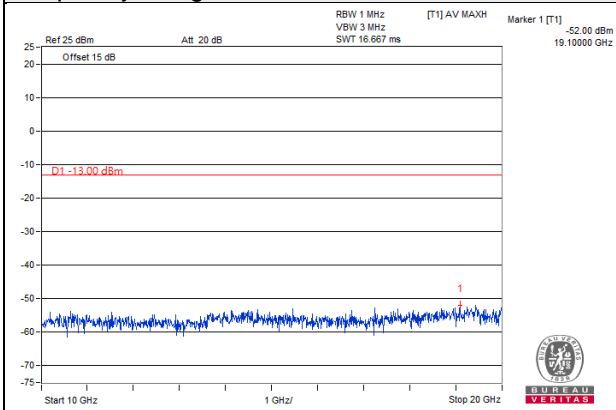

Note: The signal of 9kHz is IF signal from test instrument.

LTE Band 4 Channel Bandwidth: 15MHz

Channel 20175

Frequency Range : 9kHz~1GHz

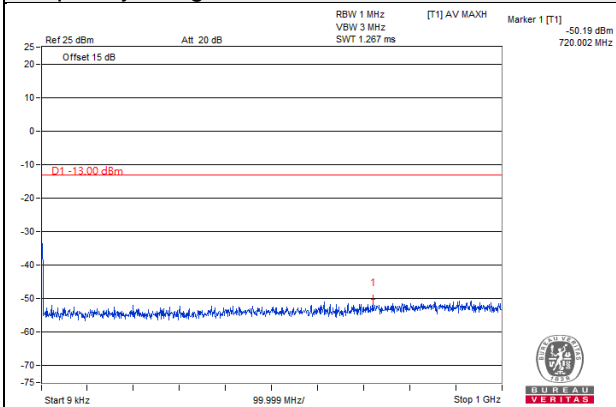

Frequency Range : 1GHz~10GHz

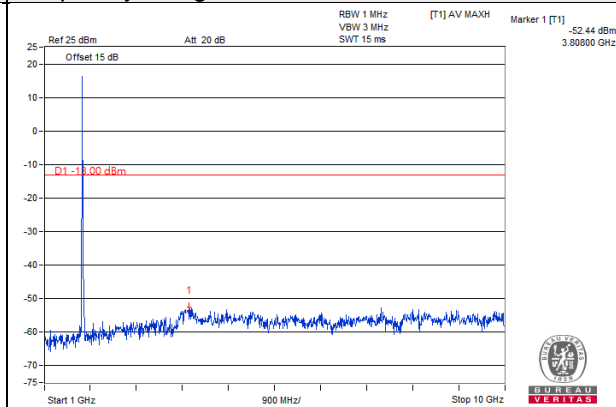

Frequency Range : 10GHz~20GHz

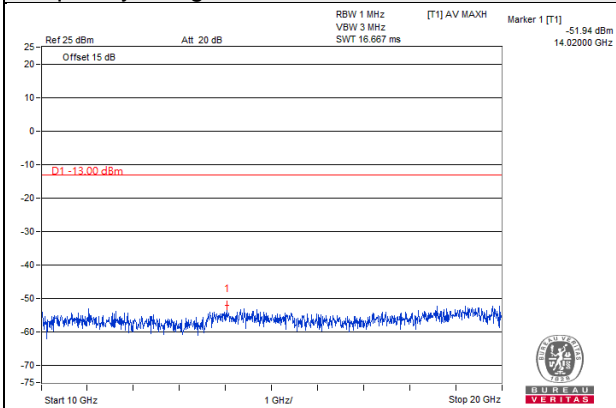

Note: The signal of 9kHz is IF signal from test instrument.

LTE Band 4 Channel Bandwidth: 15MHz

Channel 20325

Frequency Range : 9kHz~1GHz

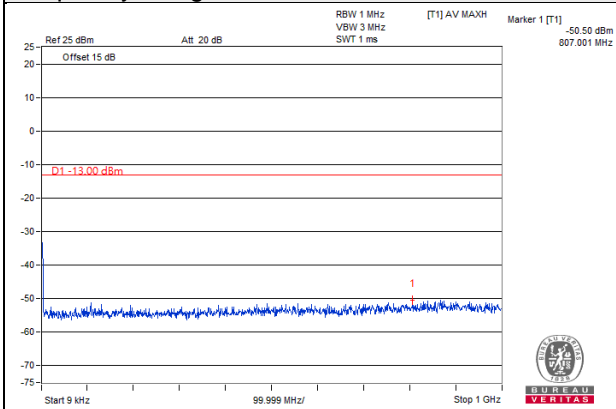

Frequency Range : 1GHz~10GHz

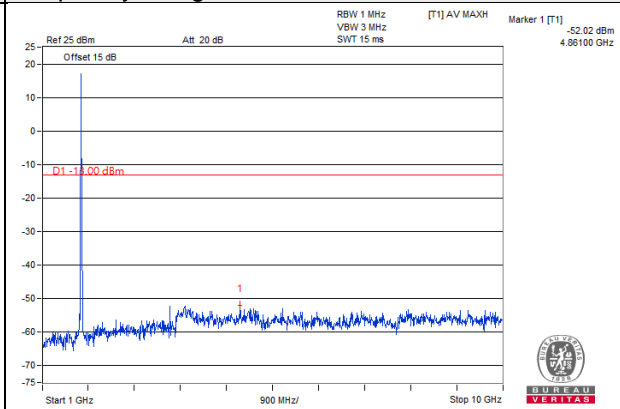

Frequency Range : 10GHz~20GHz

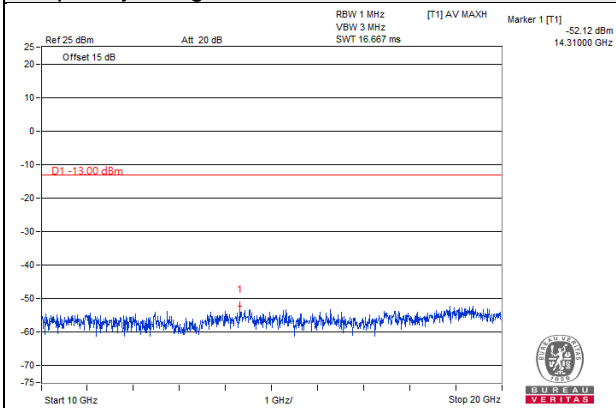

Note: The signal of 9kHz is IF signal from test instrument.

LTE Band 4 Channel Bandwidth: 20MHz

Channel 20050

Frequency Range : 9kHz~1GHz

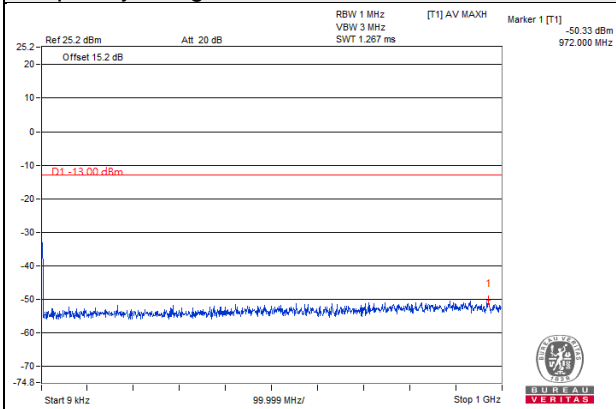

Frequency Range : 1GHz~10GHz

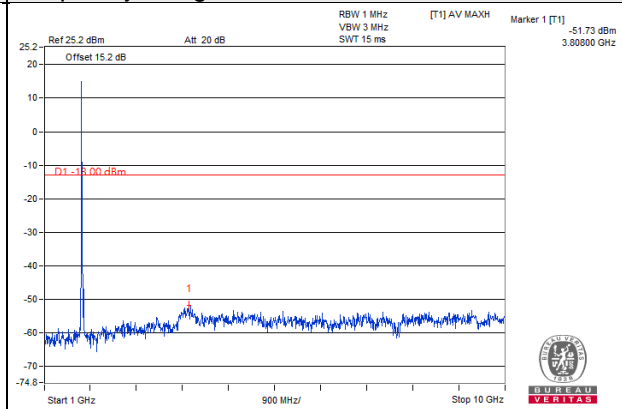

Frequency Range : 10GHz~20GHz

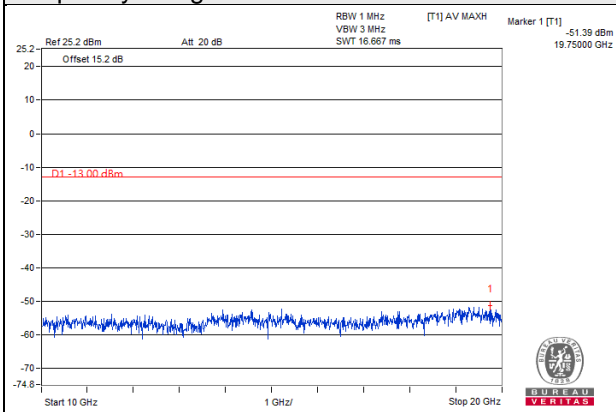

Note: The signal of 9kHz is IF signal from test instrument.

**LTE Band 4 Channel Bandwidth: 20MHz
Channel 20175**

Frequency Range : 9kHz~1GHz

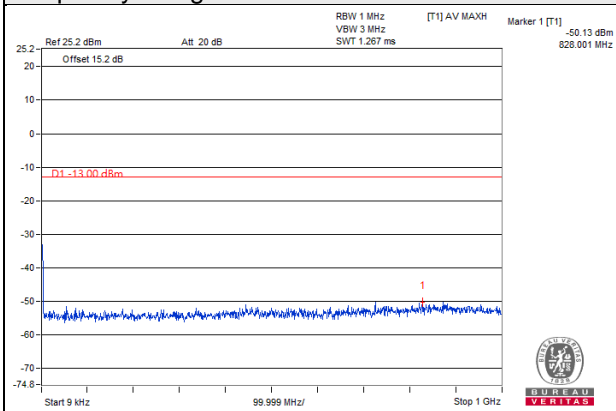

Frequency Range : 1GHz~10GHz

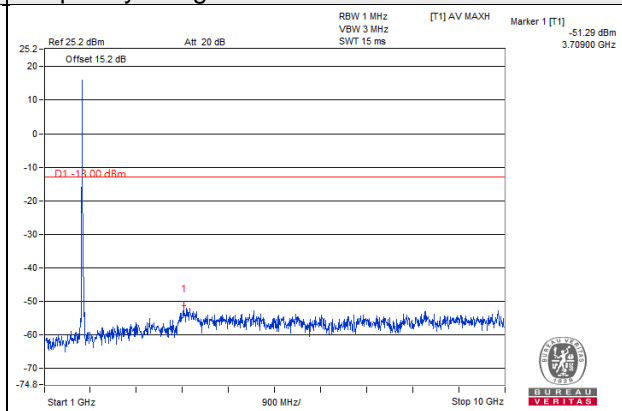

Frequency Range : 10GHz~20GHz

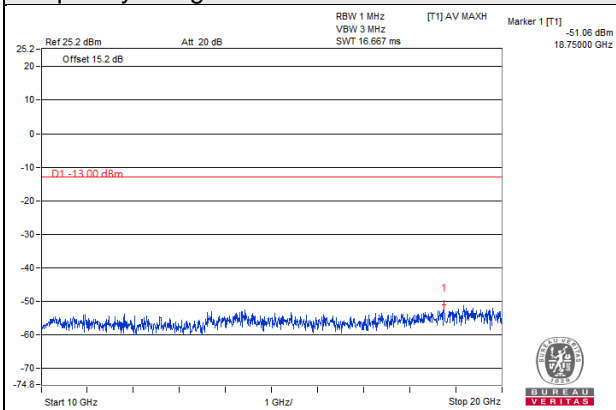

Note: The signal of 9kHz is IF signal from test instrument.

LTE Band 4 Channel Bandwidth: 20MHz

Channel 20300

Frequency Range : 9kHz~1GHz

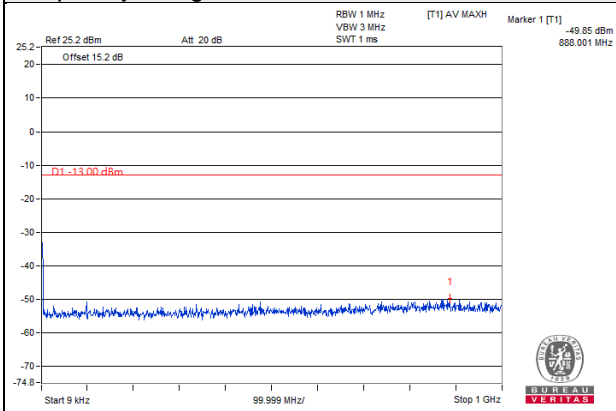

Frequency Range : 1GHz~10GHz

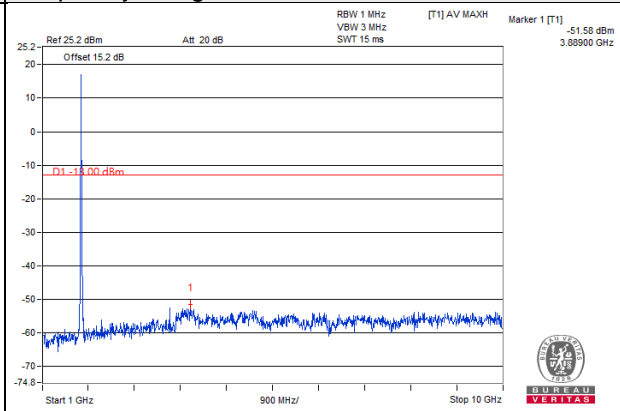

Frequency Range : 10GHz~20GHz

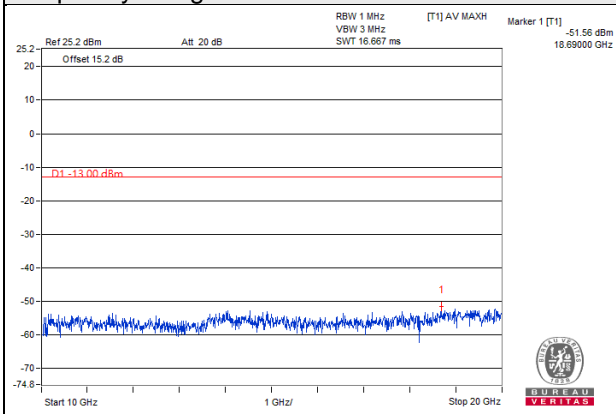

Note: The signal of 9kHz is IF signal from test instrument.

LTE Band 12 Channel Bandwidth: 1.4MHz

Channel 23017

Frequency Range : 9kHz~1GHz

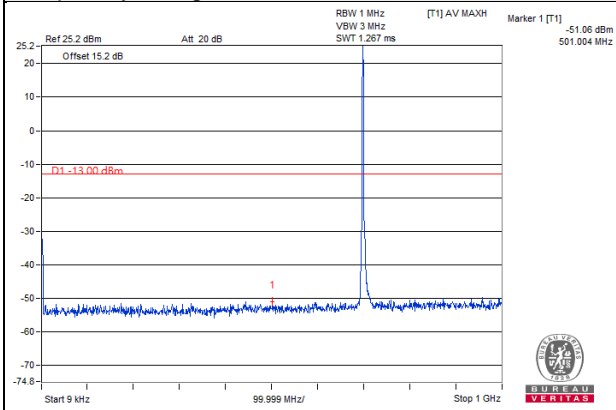

Frequency Range : 1GHz~10GHz

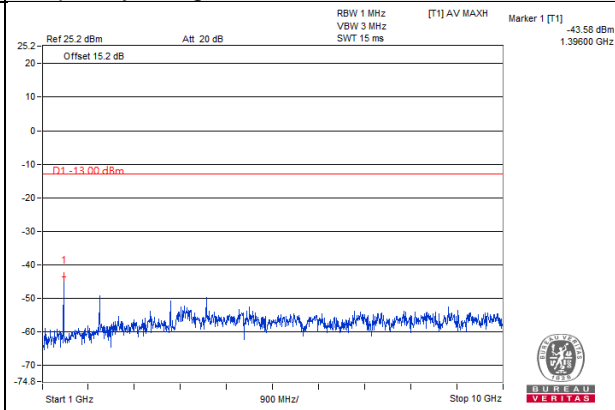

Channel 23095

Frequency Range : 9kHz~1GHz

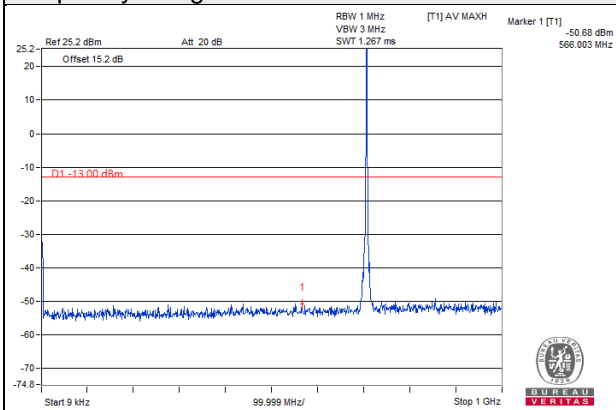

Frequency Range : 1GHz~10GHz

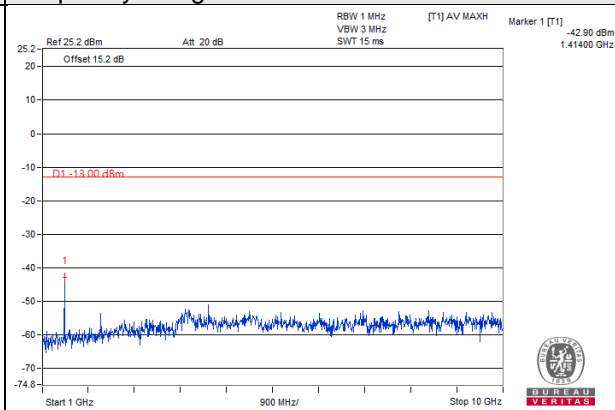

Channel 23173

Frequency Range : 9kHz~1GHz

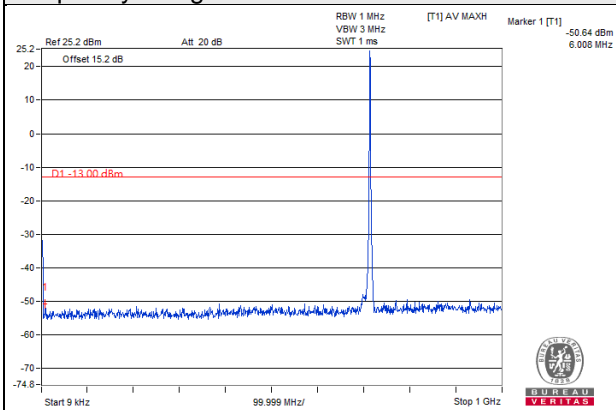

Frequency Range : 1GHz~10GHz

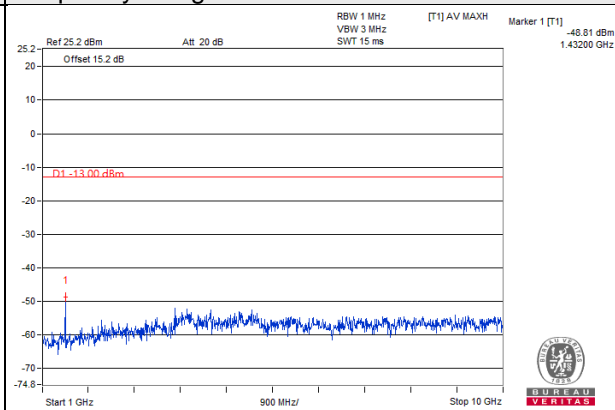

Note: The signal of 9kHz is IF signal from test instrument.

LTE Band 12 Channel Bandwidth: 3MHz

Channel 23025

Frequency Range : 9kHz~1GHz

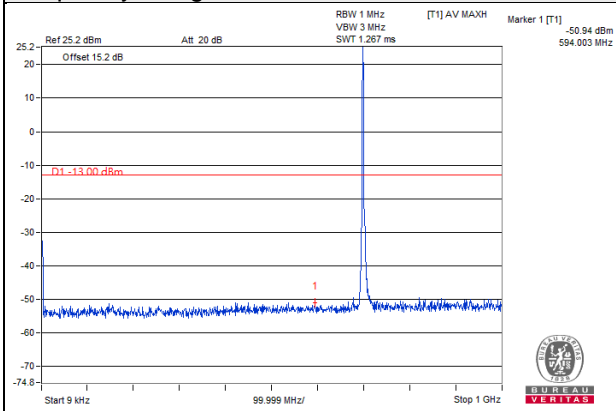

Frequency Range : 1GHz~10GHz

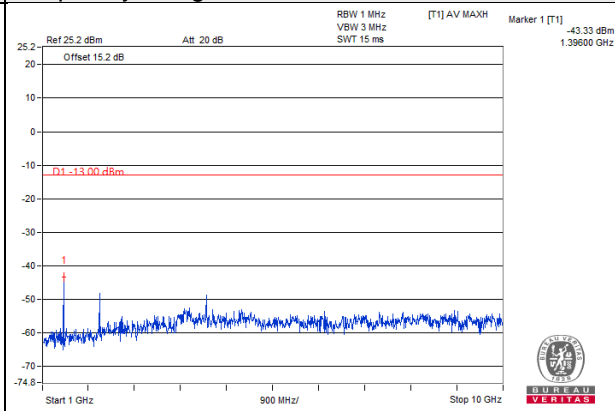

Channel 23095

Frequency Range : 9kHz~1GHz

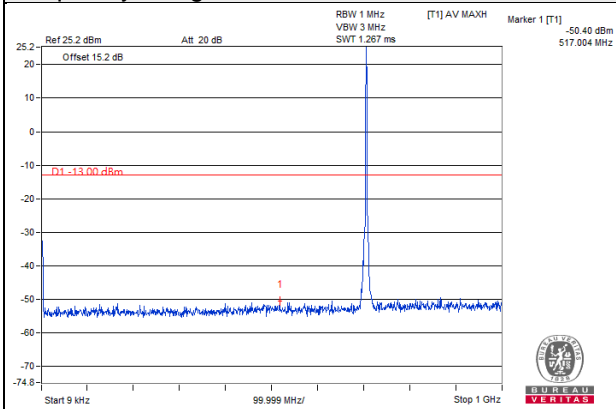

Frequency Range : 1GHz~10GHz

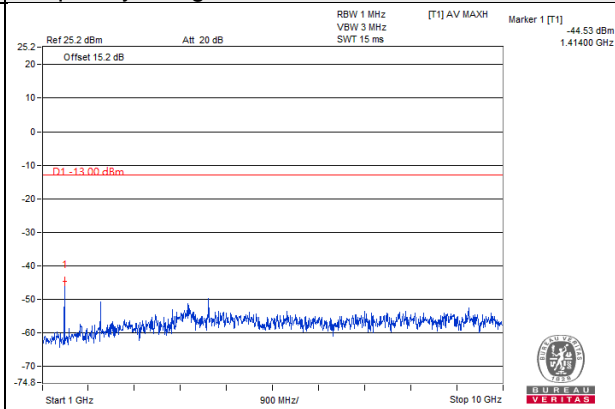

Channel 23165

Frequency Range : 9kHz~1GHz

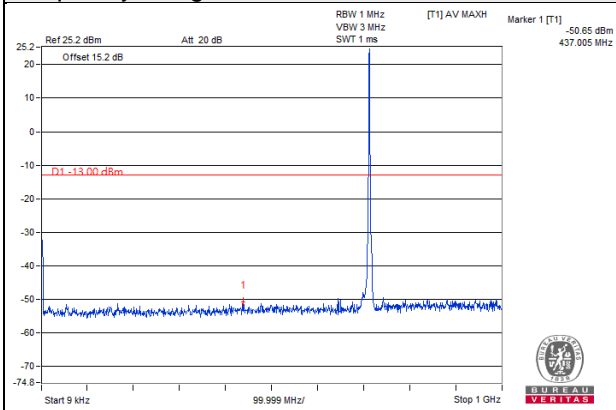

Frequency Range : 1GHz~10GHz

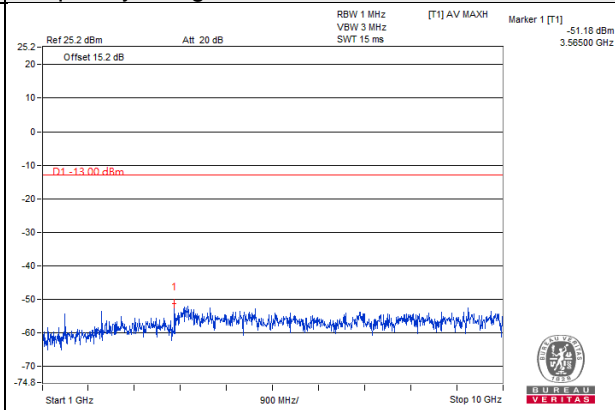

Note: The signal of 9kHz is IF signal from test instrument.

LTE Band 12 Channel Bandwidth: 5MHz

Channel 23035

Frequency Range : 9kHz~1GHz

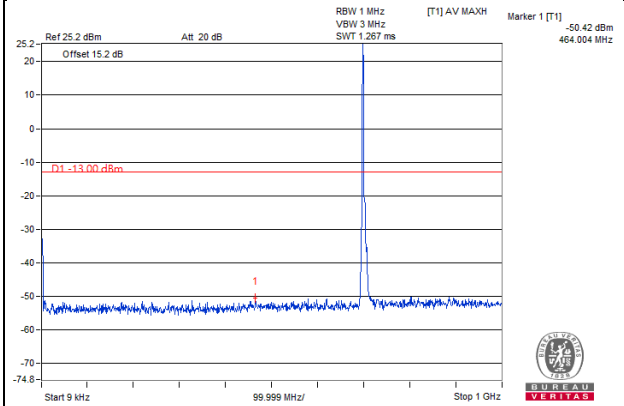

Frequency Range : 1GHz~10GHz

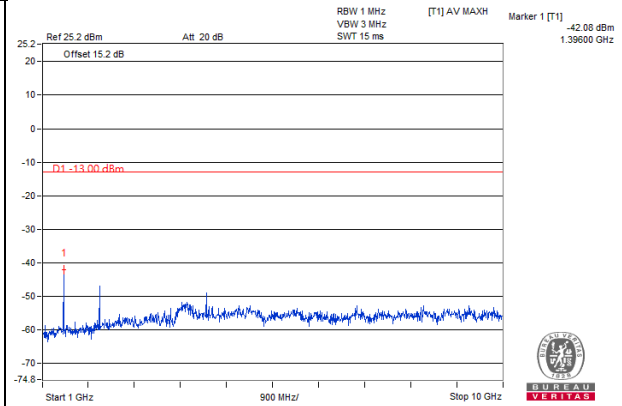

Channel 23095

Frequency Range : 9kHz~1GHz

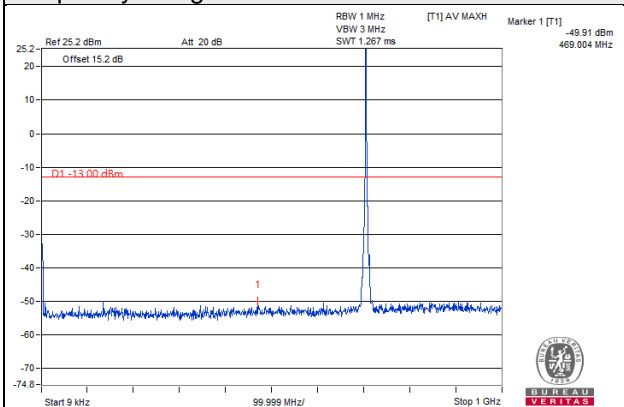

Frequency Range : 1GHz~10GHz

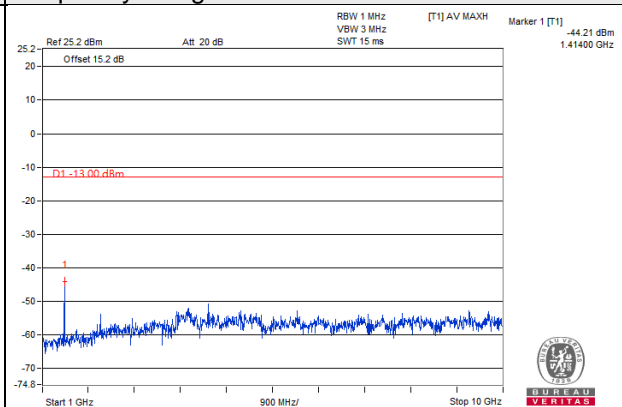

Channel 23155

Frequency Range : 9kHz~1GHz

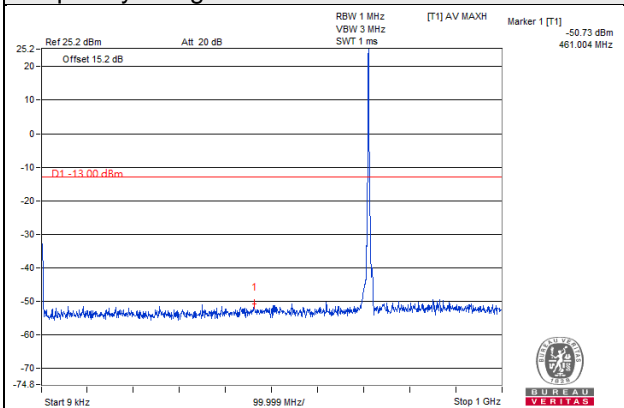

Frequency Range : 1GHz~10GHz

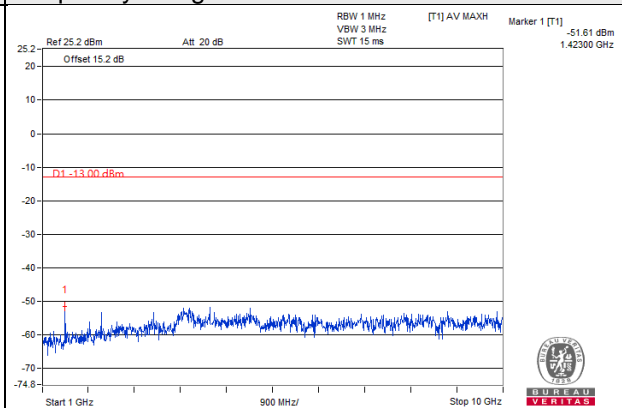

Note: The signal of 9kHz is IF signal from test instrument.

LTE Band 12 Channel Bandwidth: 10MHz

Channel 23060

Frequency Range : 9kHz~1GHz

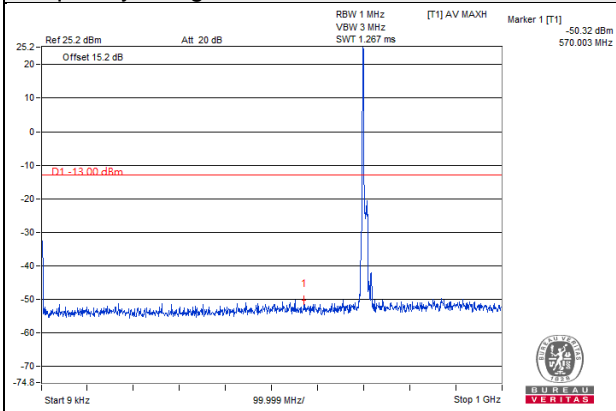

Frequency Range : 1GHz~10GHz

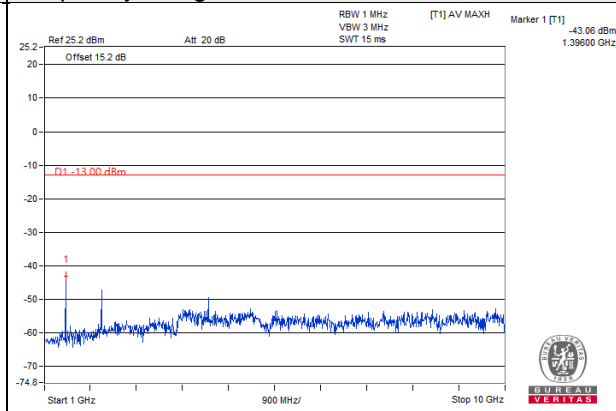

Channel 23095

Frequency Range : 9kHz~1GHz

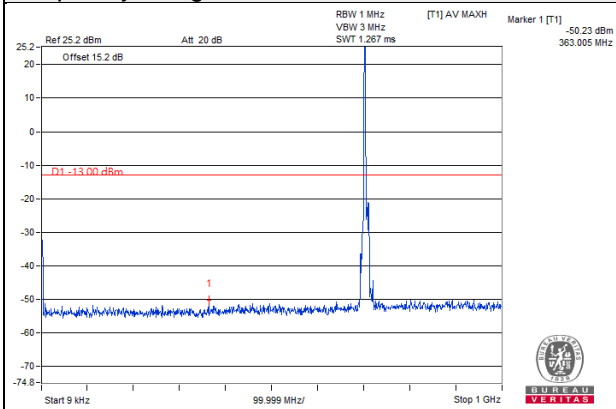

Frequency Range : 1GHz~10GHz

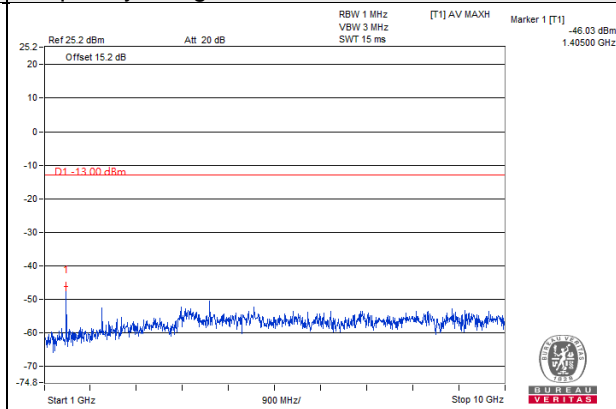

Channel 23130

Frequency Range : 9kHz~1GHz

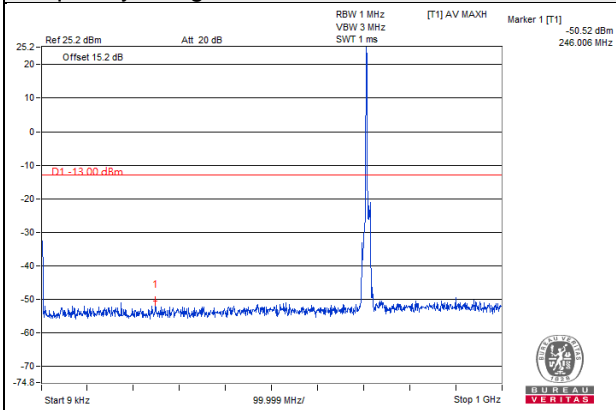

Frequency Range : 1GHz~10GHz

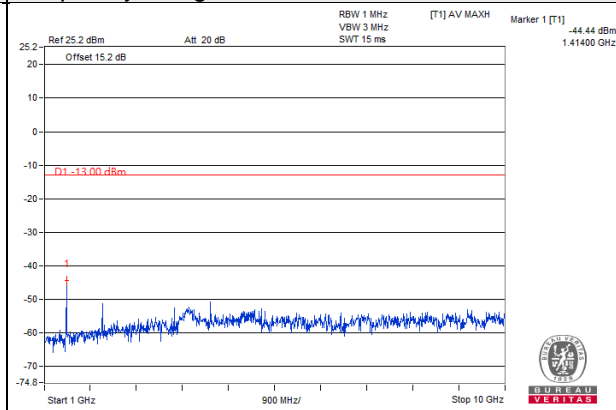

Note: The signal of 9kHz is IF signal from test instrument.

4.8 Radiated Emission Measurement

4.8.1 Limits of Radiated Emission Measurement

According to FCC 27.53(g) For operations in the 600 MHz band and the 698-746 MHz band, the power of any emission outside a licensee's frequency band(s) of operation shall be attenuated below the transmitter power (P) within the licensed band(s) of operation, measured in watts, by at least $43 + 10 \log(P)$ dB. Compliance with this provision is based on the use of measurement instrumentation employing a resolution bandwidth of 100 kilohertz or greater. However, in the 100 kilohertz bands immediately outside and adjacent to a licensee's frequency block, a resolution bandwidth of at least 30 kHz may be employed.

According to FCC 27.53(h) AWS emission limits— General protection levels. Except as otherwise specified below, for operations in the 1695-1710 MHz, 1710-1755 MHz, 1755-1780 MHz, 1915-1920 MHz, 1995-2000 MHz, 2000-2020 MHz, 2110-2155 MHz, 2155-2180 MHz, and 2180-2200 bands, the power of any emission outside a licensee's frequency block shall be attenuated below the transmitter power (P) in watts by at least $43 + 10 \log_{10}(P)$ dB.

4.8.2 Test Procedure

- a. The power was measured with Spectrum Analyzer. All measurements were done at 3 channels (low, middle and high channel of operational frequency range.)
- b. Substitution method is used for EIRP measurement. In the semi-anechoic chamber, EUT placed on the 0.8m/1.5m height of Turn Table, rotated the table around 360 degrees to search the maximum radiation power and receiver antenna shall be rotated vertical and horizontal polarization and moved height from 1m to 4m to find the maximum polar radiated power. The "Read Value" is the spectrum reading the maximum power value.
- c. Follow ANSI 63.26 section 5.2.7 d), $EIRP \text{ Value (dBm)} = \text{Read Value (dB}\mu\text{V/m)} - \text{Correction Factor @ 3m}$
- d. $\text{Correction Factor (dB) @ 3m} = 20\log(D) - 104.8$; where D is the measurement distance @ 3m = -95.26dB
- e. ERP power can be calculated from EIRP power by subtracting the gain of dipole, $ERP \text{ power} = EIRP \text{ power} - 2.15\text{dBi}$

NOTE: The resolution bandwidth and video bandwidth of test receiver/spectrum analyzer is 1MHz/3MHz.

4.8.3 Deviation from Test Standard

No deviation.

4.8.4 Test Setup

<Frequency Range below 1GHz>

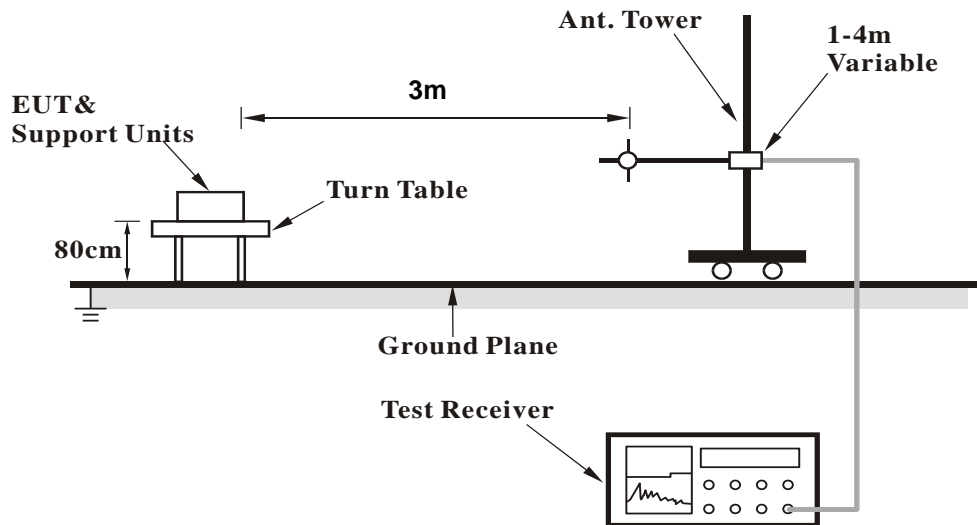

<Frequency Range above 1GHz>

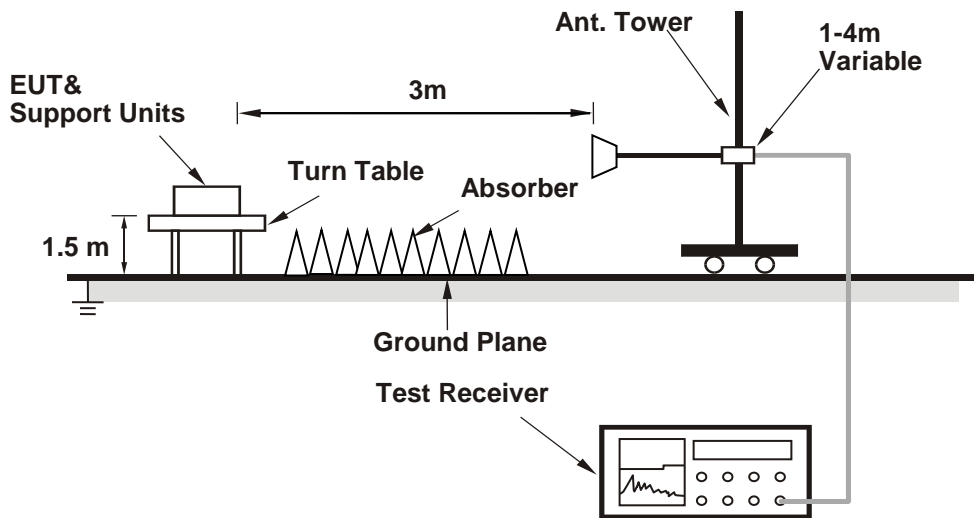

For the actual test configuration, please refer to the attached file (Test Setup Photo).

4.8.5 Test Results

Below 1GHz

LTE Band 4: 1.4MHz

Mode	TX channel 19957	Frequency Range	Below 1000 MHz
------	------------------	-----------------	----------------

Antenna Polarity & Test Distance: Horizontal at 3 M						
No.	Freq. (MHz)	Reading (dB μ V/m)	Correction Factor (dB)	Emission Value (dBm)	Limit (dBm)	Margin (dB)
1	75.5	29.6	-95.26	-65.66	-13	-52.66
2	145.24	30	-95.26	-65.26	-13	-52.26
3	197.62	29.1	-95.26	-66.16	-13	-53.16
4	301.36	37	-95.26	-58.26	-13	-45.26
5	390.11	33.6	-95.26	-61.66	-13	-48.66
6	653.31	35	-95.26	-60.26	-13	-47.26
Antenna Polarity & Test Distance: Vertical at 3 M						
No.	Freq. (MHz)	Reading (dB μ V/m)	Correction Factor (dB)	Emission Value (dBm)	Limit (dBm)	Margin (dB)
1	75.59	29	-95.26	-66.26	-13	-53.26
2	159.32	29	-95.26	-66.26	-13	-53.26
3	196.14	31.4	-95.26	-63.86	-13	-50.86
4	302.08	35.6	-95.26	-59.66	-13	-46.66
5	403.29	35.8	-95.26	-59.46	-13	-46.46
6	644.67	34.3	-95.26	-60.96	-13	-47.96

Remarks:

1. Follow ANSI 63.26 section 5.2.7 d), Emission Value (dBm) = E (dB μ V/m) - Correction Factor @ 3m.
2. Correction Factor (dB) = 20log(D) - 104.8; where D is the measurement distance @ 3m.

Mode	TX channel 20175	Frequency Range	Below 1000 MHz
------	------------------	-----------------	----------------

Antenna Polarity & Test Distance: Horizontal at 3 M

No.	Freq. (MHz)	Reading (dB μ V/m)	Correction Factor (dB)	Emission Value (dBm)	Limit (dBm)	Margin (dB)
1	73.64	29.1	-95.26	-66.16	-13	-53.16
2	159.24	28.9	-95.26	-66.36	-13	-53.36
3	206.28	29.5	-95.26	-65.76	-13	-52.76
4	293.07	37.4	-95.26	-57.86	-13	-44.86
5	392.25	34.1	-95.26	-61.16	-13	-48.16
6	649.26	34.6	-95.26	-60.66	-13	-47.66

Antenna Polarity & Test Distance: Vertical at 3 M

No.	Freq. (MHz)	Reading (dB μ V/m)	Correction Factor (dB)	Emission Value (dBm)	Limit (dBm)	Margin (dB)
1	69.39	29.6	-95.26	-65.66	-13	-52.66
2	151.68	31	-95.26	-64.26	-13	-51.26
3	195.16	32.9	-95.26	-62.36	-13	-49.36
4	297.45	36.1	-95.26	-59.16	-13	-46.16
5	406.36	35.5	-95.26	-59.76	-13	-46.76
6	643.45	34.2	-95.26	-61.06	-13	-48.06

Remarks:

1. Follow ANSI 63.26 section 5.2.7 d), Emission Value (dBm) = E (dB μ V/m) - Correction Factor @ 3m.
2. Correction Factor (dB) = 20log(D) - 104.8; where D is the measurement distance @ 3m.

Mode	TX channel 20393	Frequency Range	Below 1000 MHz
------	------------------	-----------------	----------------

Antenna Polarity & Test Distance: Horizontal at 3 M

No.	Freq. (MHz)	Reading (dB μ V/m)	Correction Factor (dB)	Emission Value (dBm)	Limit (dBm)	Margin (dB)
1	84.31	27.5	-95.26	-67.76	-13	-54.76
2	145.85	29.7	-95.26	-65.56	-13	-52.56
3	199.85	31.7	-95.26	-63.56	-13	-50.56
4	297.84	35.2	-95.26	-60.06	-13	-47.06
5	397.87	33.6	-95.26	-61.66	-13	-48.66
6	647.59	34.7	-95.26	-60.56	-13	-47.56

Antenna Polarity & Test Distance: Vertical at 3 M

No.	Freq. (MHz)	Reading (dB μ V/m)	Correction Factor (dB)	Emission Value (dBm)	Limit (dBm)	Margin (dB)
1	70.74	29.5	-95.26	-65.76	-13	-52.76
2	150.18	31.5	-95.26	-63.76	-13	-50.76
3	192.03	31.4	-95.26	-63.86	-13	-50.86
4	296.01	36.3	-95.26	-58.96	-13	-45.96
5	401.6	37	-95.26	-58.26	-13	-45.26
6	649.93	35.5	-95.26	-59.76	-13	-46.76

Remarks:

1. Follow ANSI 63.26 section 5.2.7 d), Emission Value (dBm) = E (dB μ V/m) - Correction Factor @ 3m.
2. Correction Factor (dB) = 20log(D) - 104.8; where D is the measurement distance @ 3m.

LTE Band 4: 3MHz

Mode	TX channel 19965	Frequency Range	Below 1000 MHz
------	------------------	-----------------	----------------

Antenna Polarity & Test Distance: Horizontal at 3 M

No.	Freq. (MHz)	Reading (dB μ V/m)	Correction Factor (dB)	Emission Value (dBm)	Limit (dBm)	Margin (dB)
1	70.01	28.6	-95.26	-66.66	-13	-53.66
2	157.39	29.6	-95.26	-65.66	-13	-52.66
3	205.69	32.8	-95.26	-62.46	-13	-49.46
4	291.86	36.2	-95.26	-59.06	-13	-46.06
5	393.68	33.3	-95.26	-61.96	-13	-48.96
6	644.13	36.4	-95.26	-58.86	-13	-45.86

Antenna Polarity & Test Distance: Vertical at 3 M

No.	Freq. (MHz)	Reading (dB μ V/m)	Correction Factor (dB)	Emission Value (dBm)	Limit (dBm)	Margin (dB)
1	73.85	30.8	-95.26	-64.46	-13	-51.46
2	158.71	30.1	-95.26	-65.16	-13	-52.16
3	192.42	30.5	-95.26	-64.76	-13	-51.76
4	307.93	38.2	-95.26	-57.06	-13	-44.06
5	391.68	35.9	-95.26	-59.36	-13	-46.36
6	641.29	36.5	-95.26	-58.76	-13	-45.76

Remarks:

1. Follow ANSI 63.26 section 5.2.7 d), Emission Value (dBm) = E (dB μ V/m) - Correction Factor @ 3m.
2. Correction Factor (dB) = $20\log(D) - 104.8$; where D is the measurement distance @ 3m.

Mode	TX channel 20175	Frequency Range	Below 1000 MHz
------	------------------	-----------------	----------------

Antenna Polarity & Test Distance: Horizontal at 3 M

No.	Freq. (MHz)	Reading (dB μ V/m)	Correction Factor (dB)	Emission Value (dBm)	Limit (dBm)	Margin (dB)
1	74.95	29.4	-95.26	-65.86	-13	-52.86
2	159.89	31.5	-95.26	-63.76	-13	-50.76
3	190.31	29.1	-95.26	-66.16	-13	-53.16
4	297.05	38.4	-95.26	-56.86	-13	-43.86
5	398.19	35.1	-95.26	-60.16	-13	-47.16
6	645.86	36.2	-95.26	-59.06	-13	-46.06

Antenna Polarity & Test Distance: Vertical at 3 M

No.	Freq. (MHz)	Reading (dB μ V/m)	Correction Factor (dB)	Emission Value (dBm)	Limit (dBm)	Margin (dB)
1	66.96	28.6	-95.26	-66.66	-13	-53.66
2	150.74	29.4	-95.26	-65.86	-13	-52.86
3	202.57	30.9	-95.26	-64.36	-13	-51.36
4	302.95	36.2	-95.26	-59.06	-13	-46.06
5	395.12	35.2	-95.26	-60.06	-13	-47.06
6	646.18	34.9	-95.26	-60.36	-13	-47.36

Remarks:

1. Follow ANSI 63.26 section 5.2.7 d), Emission Value (dBm) = E (dB μ V/m) - Correction Factor @ 3m.
2. Correction Factor (dB) = $20\log(D) - 104.8$; where D is the measurement distance @ 3m.

Mode	TX channel 20385	Frequency Range	Below 1000 MHz
------	------------------	-----------------	----------------

Antenna Polarity & Test Distance: Horizontal at 3 M

No.	Freq. (MHz)	Reading (dB μ V/m)	Correction Factor (dB)	Emission Value (dBm)	Limit (dBm)	Margin (dB)
1	67.49	30.1	-95.26	-65.16	-13	-52.16
2	152.52	30.5	-95.26	-64.76	-13	-51.76
3	201.83	30.6	-95.26	-64.66	-13	-51.66
4	290.97	37.5	-95.26	-57.76	-13	-44.76
5	401.91	36.1	-95.26	-59.16	-13	-46.16
6	658.36	34.7	-95.26	-60.56	-13	-47.56

Antenna Polarity & Test Distance: Vertical at 3 M

No.	Freq. (MHz)	Reading (dB μ V/m)	Correction Factor (dB)	Emission Value (dBm)	Limit (dBm)	Margin (dB)
1	71.73	27.4	-95.26	-67.86	-13	-54.86
2	143.1	30	-95.26	-65.26	-13	-52.26
3	198.84	32.6	-95.26	-62.66	-13	-49.66
4	295.36	37.2	-95.26	-58.06	-13	-45.06
5	405.83	33.3	-95.26	-61.96	-13	-48.96
6	652.86	35.9	-95.26	-59.36	-13	-46.36

Remarks:

1. Follow ANSI 63.26 section 5.2.7 d), Emission Value (dBm) = E (dB μ V/m) - Correction Factor @ 3m.
2. Correction Factor (dB) = 20log(D) - 104.8; where D is the measurement distance @ 3m.

LTE Band 4: 5MHz

Mode	TX channel 19975	Frequency Range	Below 1000 MHz
------	------------------	-----------------	----------------

Antenna Polarity & Test Distance: Horizontal at 3 M

No.	Freq. (MHz)	Reading (dB μ V/m)	Correction Factor (dB)	Emission Value (dBm)	Limit (dBm)	Margin (dB)
1	82.73	27.7	-95.26	-67.56	-13	-54.56
2	146.58	29.6	-95.26	-65.66	-13	-52.66
3	193.24	32	-95.26	-63.26	-13	-50.26
4	302.72	35.8	-95.26	-59.46	-13	-46.46
5	405.39	34.2	-95.26	-61.06	-13	-48.06
6	642.51	34.5	-95.26	-60.76	-13	-47.76

Antenna Polarity & Test Distance: Vertical at 3 M

No.	Freq. (MHz)	Reading (dB μ V/m)	Correction Factor (dB)	Emission Value (dBm)	Limit (dBm)	Margin (dB)
1	75.16	27.5	-95.26	-67.76	-13	-54.76
2	143.33	30.6	-95.26	-64.66	-13	-51.66
3	191.5	32.4	-95.26	-62.86	-13	-49.86
4	302.4	36.4	-95.26	-58.86	-13	-45.86
5	400.84	35.6	-95.26	-59.66	-13	-46.66
6	644.01	36.5	-95.26	-58.76	-13	-45.76

Remarks:

1. Follow ANSI 63.26 section 5.2.7 d), Emission Value (dBm) = E (dB μ V/m) - Correction Factor @ 3m.
2. Correction Factor (dB) = $20\log(D) - 104.8$; where D is the measurement distance @ 3m.

Mode	TX channel 20175	Frequency Range	Below 1000 MHz
------	------------------	-----------------	----------------

Antenna Polarity & Test Distance: Horizontal at 3 M

No.	Freq. (MHz)	Reading (dB μ V/m)	Correction Factor (dB)	Emission Value (dBm)	Limit (dBm)	Margin (dB)
1	79.16	27.2	-95.26	-68.06	-13	-55.06
2	158.64	30.8	-95.26	-64.46	-13	-51.46
3	208.14	30.8	-95.26	-64.46	-13	-51.46
4	307.6	37.4	-95.26	-57.86	-13	-44.86
5	397.46	36.4	-95.26	-58.86	-13	-45.86
6	644.92	35.6	-95.26	-59.66	-13	-46.66

Antenna Polarity & Test Distance: Vertical at 3 M

No.	Freq. (MHz)	Reading (dB μ V/m)	Correction Factor (dB)	Emission Value (dBm)	Limit (dBm)	Margin (dB)
1	75.86	29.9	-95.26	-65.36	-13	-52.36
2	149.57	30.8	-95.26	-64.46	-13	-51.46
3	192.38	29	-95.26	-66.26	-13	-53.26
4	309.25	36.4	-95.26	-58.86	-13	-45.86
5	393.76	36.3	-95.26	-58.96	-13	-45.96
6	640.61	37	-95.26	-58.26	-13	-45.26

Remarks:

1. Follow ANSI 63.26 section 5.2.7 d), Emission Value (dBm) = E (dB μ V/m) - Correction Factor @ 3m.
2. Correction Factor (dB) = 20log(D) - 104.8; where D is the measurement distance @ 3m.

Mode	TX channel 20375	Frequency Range	Below 1000 MHz
------	------------------	-----------------	----------------

Antenna Polarity & Test Distance: Horizontal at 3 M

No.	Freq. (MHz)	Reading (dB μ V/m)	Correction Factor (dB)	Emission Value (dBm)	Limit (dBm)	Margin (dB)
1	83.62	29.3	-95.26	-65.96	-13	-52.96
2	159.42	31.5	-95.26	-63.76	-13	-50.76
3	203.37	32.4	-95.26	-62.86	-13	-49.86
4	300.09	36.4	-95.26	-58.86	-13	-45.86
5	398.89	33.7	-95.26	-61.56	-13	-48.56
6	659.49	36	-95.26	-59.26	-13	-46.26

Antenna Polarity & Test Distance: Vertical at 3 M

No.	Freq. (MHz)	Reading (dB μ V/m)	Correction Factor (dB)	Emission Value (dBm)	Limit (dBm)	Margin (dB)
1	82.74	29	-95.26	-66.26	-13	-53.26
2	145.44	31.1	-95.26	-64.16	-13	-51.16
3	202.79	31.7	-95.26	-63.56	-13	-50.56
4	292.9	36.5	-95.26	-58.76	-13	-45.76
5	396.53	33.9	-95.26	-61.36	-13	-48.36
6	658.18	36.2	-95.26	-59.06	-13	-46.06

Remarks:

1. Follow ANSI 63.26 section 5.2.7 d), Emission Value (dBm) = E (dB μ V/m) - Correction Factor @ 3m.
2. Correction Factor (dB) = $20\log(D) - 104.8$; where D is the measurement distance @ 3m.

LTE Band 4: 10MHz

Mode	TX channel 20000	Frequency Range	Below 1000 MHz
------	------------------	-----------------	----------------

Antenna Polarity & Test Distance: Horizontal at 3 M

No.	Freq. (MHz)	Reading (dB μ V/m)	Correction Factor (dB)	Emission Value (dBm)	Limit (dBm)	Margin (dB)
1	66.67	28.4	-95.26	-66.86	-13	-53.86
2	143.89	31.8	-95.26	-63.46	-13	-50.46
3	205.23	29.7	-95.26	-65.56	-13	-52.56
4	297.05	35.5	-95.26	-59.76	-13	-46.76
5	409.91	33.9	-95.26	-61.36	-13	-48.36
6	648.29	37.8	-95.26	-57.46	-13	-44.46

Antenna Polarity & Test Distance: Vertical at 3 M

No.	Freq. (MHz)	Reading (dB μ V/m)	Correction Factor (dB)	Emission Value (dBm)	Limit (dBm)	Margin (dB)
1	65.19	28.6	-95.26	-66.66	-13	-53.66
2	151.86	29.8	-95.26	-65.46	-13	-52.46
3	204.05	29.7	-95.26	-65.56	-13	-52.56
4	309.76	36	-95.26	-59.26	-13	-46.26
5	395.14	33.2	-95.26	-62.06	-13	-49.06
6	648.48	34.4	-95.26	-60.86	-13	-47.86

Remarks:

1. Follow ANSI 63.26 section 5.2.7 d), Emission Value (dBm) = E (dB μ V/m) - Correction Factor @ 3m.
2. Correction Factor (dB) = $20\log(D) - 104.8$; where D is the measurement distance @ 3m.

Mode	TX channel 20175	Frequency Range	Below 1000 MHz
------	------------------	-----------------	----------------

Antenna Polarity & Test Distance: Horizontal at 3 M

No.	Freq. (MHz)	Reading (dB μ V/m)	Correction Factor (dB)	Emission Value (dBm)	Limit (dBm)	Margin (dB)
1	72.88	29.9	-95.26	-65.36	-13	-52.36
2	152.87	29.3	-95.26	-65.96	-13	-52.96
3	192.08	32.4	-95.26	-62.86	-13	-49.86
4	294.13	38.6	-95.26	-56.66	-13	-43.66
5	390.35	36.1	-95.26	-59.16	-13	-46.16
6	644.91	36.2	-95.26	-59.06	-13	-46.06

Antenna Polarity & Test Distance: Vertical at 3 M

No.	Freq. (MHz)	Reading (dB μ V/m)	Correction Factor (dB)	Emission Value (dBm)	Limit (dBm)	Margin (dB)
1	71.25	28.5	-95.26	-66.76	-13	-53.76
2	149.43	28.6	-95.26	-66.66	-13	-53.66
3	200.45	30.3	-95.26	-64.96	-13	-51.96
4	303.34	37.9	-95.26	-57.36	-13	-44.36
5	402.39	36.4	-95.26	-58.86	-13	-45.86
6	659.99	38	-95.26	-57.26	-13	-44.26

Remarks:

1. Follow ANSI 63.26 section 5.2.7 d), Emission Value (dBm) = E (dB μ V/m) - Correction Factor @ 3m.
2. Correction Factor (dB) = $20\log(D) - 104.8$; where D is the measurement distance @ 3m.

Mode	TX channel 20350	Frequency Range	Below 1000 MHz
------	------------------	-----------------	----------------

Antenna Polarity & Test Distance: Horizontal at 3 M

No.	Freq. (MHz)	Reading (dB μ V/m)	Correction Factor (dB)	Emission Value (dBm)	Limit (dBm)	Margin (dB)
1	74.44	28.2	-95.26	-67.06	-13	-54.06
2	159.74	29.6	-95.26	-65.66	-13	-52.66
3	203.52	31.3	-95.26	-63.96	-13	-50.96
4	293.48	37.3	-95.26	-57.96	-13	-44.96
5	396.21	35.7	-95.26	-59.56	-13	-46.56
6	647.56	35.5	-95.26	-59.76	-13	-46.76

Antenna Polarity & Test Distance: Vertical at 3 M

No.	Freq. (MHz)	Reading (dB μ V/m)	Correction Factor (dB)	Emission Value (dBm)	Limit (dBm)	Margin (dB)
1	65.21	27.2	-95.26	-68.06	-13	-55.06
2	150.53	30	-95.26	-65.26	-13	-52.26
3	200.75	30	-95.26	-65.26	-13	-52.26
4	302.77	36	-95.26	-59.26	-13	-46.26
5	394.41	34.8	-95.26	-60.46	-13	-47.46
6	651.33	34.6	-95.26	-60.66	-13	-47.66

Remarks:

1. Follow ANSI 63.26 section 5.2.7 d), Emission Value (dBm) = E (dB μ V/m) - Correction Factor @ 3m.
2. Correction Factor (dB) = 20log(D) – 104.8; where D is the measurement distance @ 3m.

LTE Band 4: 15MHz

Mode	TX channel 20025	Frequency Range	Below 1000 MHz
------	------------------	-----------------	----------------

Antenna Polarity & Test Distance: Horizontal at 3 M

No.	Freq. (MHz)	Reading (dB μ V/m)	Correction Factor (dB)	Emission Value (dBm)	Limit (dBm)	Margin (dB)
1	71.27	28.7	-95.26	-66.56	-13	-53.56
2	159.06	30.4	-95.26	-64.86	-13	-51.86
3	192.58	31.3	-95.26	-63.96	-13	-50.96
4	296.32	35.1	-95.26	-60.16	-13	-47.16
5	398.47	34.5	-95.26	-60.76	-13	-47.76
6	645.81	38	-95.26	-57.26	-13	-44.26

Antenna Polarity & Test Distance: Vertical at 3 M

No.	Freq. (MHz)	Reading (dB μ V/m)	Correction Factor (dB)	Emission Value (dBm)	Limit (dBm)	Margin (dB)
1	82.21	28.3	-95.26	-66.96	-13	-53.96
2	157.63	29.3	-95.26	-65.96	-13	-52.96
3	191.38	31.5	-95.26	-63.76	-13	-50.76
4	295.93	38.1	-95.26	-57.16	-13	-44.16
5	405.12	34.6	-95.26	-60.66	-13	-47.66
6	645.27	36.6	-95.26	-58.66	-13	-45.66

Remarks:

1. Follow ANSI 63.26 section 5.2.7 d), Emission Value (dBm) = E (dB μ V/m) - Correction Factor @ 3m.
2. Correction Factor (dB) = $20\log(D) - 104.8$; where D is the measurement distance @ 3m.

Mode	TX channel 20175	Frequency Range	Below 1000 MHz
------	------------------	-----------------	----------------

Antenna Polarity & Test Distance: Horizontal at 3 M

No.	Freq. (MHz)	Reading (dB μ V/m)	Correction Factor (dB)	Emission Value (dBm)	Limit (dBm)	Margin (dB)
1	80.47	27.7	-95.26	-67.56	-13	-54.56
2	152.14	31.3	-95.26	-63.96	-13	-50.96
3	205.54	29.5	-95.26	-65.76	-13	-52.76
4	305.82	37.3	-95.26	-57.96	-13	-44.96
5	394.34	36.7	-95.26	-58.56	-13	-45.56
6	649.34	35.4	-95.26	-59.86	-13	-46.86

Antenna Polarity & Test Distance: Vertical at 3 M

No.	Freq. (MHz)	Reading (dB μ V/m)	Correction Factor (dB)	Emission Value (dBm)	Limit (dBm)	Margin (dB)
1	74.38	28.1	-95.26	-67.16	-13	-54.16
2	145.12	30.4	-95.26	-64.86	-13	-51.86
3	197.85	32.5	-95.26	-62.76	-13	-49.76
4	291.64	35.1	-95.26	-60.16	-13	-47.16
5	409.01	34.3	-95.26	-60.96	-13	-47.96
6	640.15	36.8	-95.26	-58.46	-13	-45.46

Remarks:

1. Follow ANSI 63.26 section 5.2.7 d), Emission Value (dBm) = E (dB μ V/m) - Correction Factor @ 3m.
2. Correction Factor (dB) = 20log(D) - 104.8; where D is the measurement distance @ 3m.

Mode	TX channel 20325	Frequency Range	Below 1000 MHz
------	------------------	-----------------	----------------

Antenna Polarity & Test Distance: Horizontal at 3 M

No.	Freq. (MHz)	Reading (dB μ V/m)	Correction Factor (dB)	Emission Value (dBm)	Limit (dBm)	Margin (dB)
1	77.87	28.5	-95.26	-66.76	-13	-53.76
2	150.37	30.8	-95.26	-64.46	-13	-51.46
3	207.56	30.5	-95.26	-64.76	-13	-51.76
4	301.68	38.9	-95.26	-56.36	-13	-43.36
5	408.19	36.4	-95.26	-58.86	-13	-45.86
6	653.4	37.6	-95.26	-57.66	-13	-44.66

Antenna Polarity & Test Distance: Vertical at 3 M

No.	Freq. (MHz)	Reading (dB μ V/m)	Correction Factor (dB)	Emission Value (dBm)	Limit (dBm)	Margin (dB)
1	68.28	30	-95.26	-65.26	-13	-52.26
2	144	28.7	-95.26	-66.56	-13	-53.56
3	190.15	30.8	-95.26	-64.46	-13	-51.46
4	292.1	35.8	-95.26	-59.46	-13	-46.46
5	390.84	35.8	-95.26	-59.46	-13	-46.46
6	652.47	36.4	-95.26	-58.86	-13	-45.86

Remarks:

1. Follow ANSI 63.26 section 5.2.7 d), Emission Value (dBm) = E (dB μ V/m) - Correction Factor @ 3m.
2. Correction Factor (dB) = $20\log(D) - 104.8$; where D is the measurement distance @ 3m.

LTE Band 4: 20MHz

Mode	TX channel 20050	Frequency Range	Below 1000 MHz
------	------------------	-----------------	----------------

Antenna Polarity & Test Distance: Horizontal at 3 M

No.	Freq. (MHz)	Reading (dB μ V/m)	Correction Factor (dB)	Emission Value (dBm)	Limit (dBm)	Margin (dB)
1	70.78	27.3	-95.26	-67.96	-13	-54.96
2	159.94	31.6	-95.26	-63.66	-13	-50.66
3	208.74	31.2	-95.26	-64.06	-13	-51.06
4	301.64	36.1	-95.26	-59.16	-13	-46.16
5	406.78	33.9	-95.26	-61.36	-13	-48.36
6	643.21	36.4	-95.26	-58.86	-13	-45.86

Antenna Polarity & Test Distance: Vertical at 3 M

No.	Freq. (MHz)	Reading (dB μ V/m)	Correction Factor (dB)	Emission Value (dBm)	Limit (dBm)	Margin (dB)
1	66.7	29.6	-95.26	-65.66	-13	-52.66
2	153.34	30.6	-95.26	-64.66	-13	-51.66
3	208.2	31.8	-95.26	-63.46	-13	-50.46
4	306.81	36.2	-95.26	-59.06	-13	-46.06
5	392.69	35.9	-95.26	-59.36	-13	-46.36
6	659.72	36.4	-95.26	-58.86	-13	-45.86

Remarks:

1. Follow ANSI 63.26 section 5.2.7 d), Emission Value (dBm) = E (dB μ V/m) - Correction Factor @ 3m.
2. Correction Factor (dB) = $20\log(D) - 104.8$; where D is the measurement distance @ 3m.

Mode	TX channel 20175	Frequency Range	Below 1000 MHz
------	------------------	-----------------	----------------

Antenna Polarity & Test Distance: Horizontal at 3 M

No.	Freq. (MHz)	Reading (dB μ V/m)	Correction Factor (dB)	Emission Value (dBm)	Limit (dBm)	Margin (dB)
1	66.73	30.7	-95.26	-64.56	-13	-51.56
2	142.27	31.4	-95.26	-63.86	-13	-50.86
3	204.03	29.8	-95.26	-65.46	-13	-52.46
4	308.29	35.1	-95.26	-60.16	-13	-47.16
5	391.46	36.6	-95.26	-58.66	-13	-45.66
6	644.1	38	-95.26	-57.26	-13	-44.26

Antenna Polarity & Test Distance: Vertical at 3 M

No.	Freq. (MHz)	Reading (dB μ V/m)	Correction Factor (dB)	Emission Value (dBm)	Limit (dBm)	Margin (dB)
1	74.01	28	-95.26	-67.26	-13	-54.26
2	151.52	30.5	-95.26	-64.76	-13	-51.76
3	195.52	30.6	-95.26	-64.66	-13	-51.66
4	297.63	36.1	-95.26	-59.16	-13	-46.16
5	391.35	36.1	-95.26	-59.16	-13	-46.16
6	640.86	37.5	-95.26	-57.76	-13	-44.76

Remarks:

1. Follow ANSI 63.26 section 5.2.7 d), Emission Value (dBm) = E (dB μ V/m) - Correction Factor @ 3m.
2. Correction Factor (dB) = 20log(D) - 104.8; where D is the measurement distance @ 3m.

Mode	TX channel 20300	Frequency Range	Below 1000 MHz
------	------------------	-----------------	----------------

Antenna Polarity & Test Distance: Horizontal at 3 M

No.	Freq. (MHz)	Reading (dB μ V/m)	Correction Factor (dB)	Emission Value (dBm)	Limit (dBm)	Margin (dB)
1	74.43	30.7	-95.26	-64.56	-13	-51.56
2	156.12	31.6	-95.26	-63.66	-13	-50.66
3	204.79	31.5	-95.26	-63.76	-13	-50.76
4	300.66	36.9	-95.26	-58.36	-13	-45.36
5	394.73	36.6	-95.26	-58.66	-13	-45.66
6	645.9	37.9	-95.26	-57.36	-13	-44.36

Antenna Polarity & Test Distance: Vertical at 3 M

No.	Freq. (MHz)	Reading (dB μ V/m)	Correction Factor (dB)	Emission Value (dBm)	Limit (dBm)	Margin (dB)
1	73.13	30.6	-95.26	-64.66	-13	-51.66
2	157.72	28	-95.26	-67.26	-13	-54.26
3	197.73	29.4	-95.26	-65.86	-13	-52.86
4	303.35	36.9	-95.26	-58.36	-13	-45.36
5	391.61	35.2	-95.26	-60.06	-13	-47.06
6	642.52	36.3	-95.26	-58.96	-13	-45.96

Remarks:

1. Follow ANSI 63.26 section 5.2.7 d), Emission Value (dBm) = E (dB μ V/m) - Correction Factor @ 3m.
2. Correction Factor (dB) = 20log(D) - 104.8; where D is the measurement distance @ 3m.

LTE Band 12: 1.4MHz

Mode	TX channel 23017	Frequency Range	Below 1000 MHz
------	------------------	-----------------	----------------

Antenna Polarity & Test Distance: Horizontal at 3 M

No.	Freq. (MHz)	Reading (dB μ V/m)	Correction Factor (dB)	Emission Value (dBm)	Limit (dBm)	Margin (dB)
1	78.95	27.1	-95.26	-68.16	-13	-55.16
2	141.46	31.6	-95.26	-63.66	-13	-50.66
3	206.57	29.1	-95.26	-66.16	-13	-53.16
4	292.63	35.3	-95.26	-59.96	-13	-46.96
5	390.69	34.9	-95.26	-60.36	-13	-47.36
6	645.27	36	-95.26	-59.26	-13	-46.26

Antenna Polarity & Test Distance: Vertical at 3 M

No.	Freq. (MHz)	Reading (dB μ V/m)	Correction Factor (dB)	Emission Value (dBm)	Limit (dBm)	Margin (dB)
1	65.06	28.6	-95.26	-66.66	-13	-53.66
2	142.06	28.5	-95.26	-66.76	-13	-53.76
3	196.18	32.4	-95.26	-62.86	-13	-49.86
4	293.72	38	-95.26	-57.26	-13	-44.26
5	403.94	33.7	-95.26	-61.56	-13	-48.56
6	647.78	35.5	-95.26	-59.76	-13	-46.76

Remarks:

1. Follow ANSI 63.26 section 5.2.7 d), Emission Value (dBm) = E (dB μ V/m) - Correction Factor @ 3m.
2. Correction Factor (dB) = $20\log(D) - 104.8$; where D is the measurement distance @ 3m.

Mode	TX channel 23095	Frequency Range	Below 1000 MHz
------	------------------	-----------------	----------------

Antenna Polarity & Test Distance: Horizontal at 3 M

No.	Freq. (MHz)	Reading (dB μ V/m)	Correction Factor (dB)	Emission Value (dBm)	Limit (dBm)	Margin (dB)
1	73.84	27.5	-95.26	-67.76	-13	-54.76
2	153.97	29.5	-95.26	-65.76	-13	-52.76
3	192.27	31.9	-95.26	-63.36	-13	-50.36
4	290.53	37.7	-95.26	-57.56	-13	-44.56
5	394.69	36.7	-95.26	-58.56	-13	-45.56
6	643.42	34.2	-95.26	-61.06	-13	-48.06

Antenna Polarity & Test Distance: Vertical at 3 M

No.	Freq. (MHz)	Reading (dB μ V/m)	Correction Factor (dB)	Emission Value (dBm)	Limit (dBm)	Margin (dB)
1	78.09	28.3	-95.26	-66.96	-13	-53.96
2	142.47	32	-95.26	-63.26	-13	-50.26
3	195.51	30.9	-95.26	-64.36	-13	-51.36
4	302.29	38	-95.26	-57.26	-13	-44.26
5	408.06	34.8	-95.26	-60.46	-13	-47.46
6	655.7	35.7	-95.26	-59.56	-13	-46.56

Remarks:

1. Follow ANSI 63.26 section 5.2.7 d), Emission Value (dBm) = E (dB μ V/m) - Correction Factor @ 3m.
2. Correction Factor (dB) = 20log(D) - 104.8; where D is the measurement distance @ 3m.

Mode	TX channel 23173	Frequency Range	Below 1000 MHz
------	------------------	-----------------	----------------

Antenna Polarity & Test Distance: Horizontal at 3 M

No.	Freq. (MHz)	Reading (dB μ V/m)	Correction Factor (dB)	Emission Value (dBm)	Limit (dBm)	Margin (dB)
1	80.63	28.6	-95.26	-66.66	-13	-53.66
2	146.8	31.9	-95.26	-63.36	-13	-50.36
3	197.84	29.7	-95.26	-65.56	-13	-52.56
4	303.18	36.3	-95.26	-58.96	-13	-45.96
5	397.43	34.5	-95.26	-60.76	-13	-47.76
6	659.95	36.5	-95.26	-58.76	-13	-45.76

Antenna Polarity & Test Distance: Vertical at 3 M

No.	Freq. (MHz)	Reading (dB μ V/m)	Correction Factor (dB)	Emission Value (dBm)	Limit (dBm)	Margin (dB)
1	74.78	28.2	-95.26	-67.06	-13	-54.06
2	142.43	31.1	-95.26	-64.16	-13	-51.16
3	202.33	30.9	-95.26	-64.36	-13	-51.36
4	308.68	36.8	-95.26	-58.46	-13	-45.46
5	409.31	34.6	-95.26	-60.66	-13	-47.66
6	650.01	34.7	-95.26	-60.56	-13	-47.56

Remarks:

1. Follow ANSI 63.26 section 5.2.7 d), Emission Value (dBm) = E (dB μ V/m) - Correction Factor @ 3m.
2. Correction Factor (dB) = $20\log(D) - 104.8$; where D is the measurement distance @ 3m.

LTE Band 12: 3MHz

Mode	TX channel 23025	Frequency Range	Below 1000 MHz
------	------------------	-----------------	----------------

Antenna Polarity & Test Distance: Horizontal at 3 M

No.	Freq. (MHz)	Reading (dB μ V/m)	Correction Factor (dB)	Emission Value (dBm)	Limit (dBm)	Margin (dB)
1	76.77	29.9	-95.26	-65.36	-13	-52.36
2	157.25	28.7	-95.26	-66.56	-13	-53.56
3	195.22	29.6	-95.26	-65.66	-13	-52.66
4	292.07	38	-95.26	-57.26	-13	-44.26
5	390.31	33.5	-95.26	-61.76	-13	-48.76
6	642.64	37.2	-95.26	-58.06	-13	-45.06

Antenna Polarity & Test Distance: Vertical at 3 M

No.	Freq. (MHz)	Reading (dB μ V/m)	Correction Factor (dB)	Emission Value (dBm)	Limit (dBm)	Margin (dB)
1	70.73	27.7	-95.26	-67.56	-13	-54.56
2	145.05	29.6	-95.26	-65.66	-13	-52.66
3	205.05	32.2	-95.26	-63.06	-13	-50.06
4	302.03	38.1	-95.26	-57.16	-13	-44.16
5	403.92	35	-95.26	-60.26	-13	-47.26
6	649.9	36.5	-95.26	-58.76	-13	-45.76

Remarks:

1. Follow ANSI 63.26 section 5.2.7 d), Emission Value (dBm) = E (dB μ V/m) - Correction Factor @ 3m.
2. Correction Factor (dB) = $20\log(D) - 104.8$; where D is the measurement distance @ 3m.

Mode	TX channel 23095	Frequency Range	Below 1000 MHz
------	------------------	-----------------	----------------

Antenna Polarity & Test Distance: Horizontal at 3 M

No.	Freq. (MHz)	Reading (dB μ V/m)	Correction Factor (dB)	Emission Value (dBm)	Limit (dBm)	Margin (dB)
1	65.28	27.9	-95.26	-67.36	-13	-54.36
2	145.51	29.1	-95.26	-66.16	-13	-53.16
3	200.56	29.4	-95.26	-65.86	-13	-52.86
4	297.22	35.1	-95.26	-60.16	-13	-47.16
5	397.31	36.2	-95.26	-59.06	-13	-46.06
6	654.47	34	-95.26	-61.26	-13	-48.26

Antenna Polarity & Test Distance: Vertical at 3 M

No.	Freq. (MHz)	Reading (dB μ V/m)	Correction Factor (dB)	Emission Value (dBm)	Limit (dBm)	Margin (dB)
1	66.53	29.7	-95.26	-65.56	-13	-52.56
2	158.23	31.4	-95.26	-63.86	-13	-50.86
3	198.44	32.4	-95.26	-62.86	-13	-49.86
4	309.84	38.1	-95.26	-57.16	-13	-44.16
5	406.47	35.4	-95.26	-59.86	-13	-46.86
6	657.97	36.1	-95.26	-59.16	-13	-46.16

Remarks:

1. Follow ANSI 63.26 section 5.2.7 d), Emission Value (dBm) = E (dB μ V/m) - Correction Factor @ 3m.
2. Correction Factor (dB) = 20log(D) - 104.8; where D is the measurement distance @ 3m.

Mode	TX channel 23165	Frequency Range	Below 1000 MHz
------	------------------	-----------------	----------------

Antenna Polarity & Test Distance: Horizontal at 3 M

No.	Freq. (MHz)	Reading (dB μ V/m)	Correction Factor (dB)	Emission Value (dBm)	Limit (dBm)	Margin (dB)
1	67.68	29.1	-95.26	-66.16	-13	-53.16
2	148.53	31.7	-95.26	-63.56	-13	-50.56
3	197.01	31.6	-95.26	-63.66	-13	-50.66
4	307.25	37	-95.26	-58.26	-13	-45.26
5	391.26	35	-95.26	-60.26	-13	-47.26
6	653.59	36.7	-95.26	-58.56	-13	-45.56

Antenna Polarity & Test Distance: Vertical at 3 M

No.	Freq. (MHz)	Reading (dB μ V/m)	Correction Factor (dB)	Emission Value (dBm)	Limit (dBm)	Margin (dB)
1	78.39	30.6	-95.26	-64.66	-13	-51.66
2	147.01	28.6	-95.26	-66.66	-13	-53.66
3	191.81	30.9	-95.26	-64.36	-13	-51.36
4	291.22	38.5	-95.26	-56.76	-13	-43.76
5	390.66	33.2	-95.26	-62.06	-13	-49.06
6	656.54	37.6	-95.26	-57.66	-13	-44.66

Remarks:

1. Follow ANSI 63.26 section 5.2.7 d), Emission Value (dBm) = E (dB μ V/m) - Correction Factor @ 3m.
2. Correction Factor (dB) = 20log(D) - 104.8; where D is the measurement distance @ 3m.

LTE Band 12: 5MHz

Mode	TX channel 23035	Frequency Range	Below 1000 MHz
------	------------------	-----------------	----------------

Antenna Polarity & Test Distance: Horizontal at 3 M

No.	Freq. (MHz)	Reading (dB μ V/m)	Correction Factor (dB)	Emission Value (dBm)	Limit (dBm)	Margin (dB)
1	71.16	27	-95.26	-68.26	-13	-55.26
2	146.6	29.3	-95.26	-65.96	-13	-52.96
3	205.55	30.2	-95.26	-65.06	-13	-52.06
4	294.9	35.5	-95.26	-59.76	-13	-46.76
5	390.16	33.1	-95.26	-62.16	-13	-49.16
6	640.63	36.2	-95.26	-59.06	-13	-46.06

Antenna Polarity & Test Distance: Vertical at 3 M

No.	Freq. (MHz)	Reading (dB μ V/m)	Correction Factor (dB)	Emission Value (dBm)	Limit (dBm)	Margin (dB)
1	84.19	28.1	-95.26	-67.16	-13	-54.16
2	154.09	28.8	-95.26	-66.46	-13	-53.46
3	209.79	30.8	-95.26	-64.46	-13	-51.46
4	303.93	35.5	-95.26	-59.76	-13	-46.76
5	391.44	34.5	-95.26	-60.76	-13	-47.76
6	640.38	36.1	-95.26	-59.16	-13	-46.16

Remarks:

1. Follow ANSI 63.26 section 5.2.7 d), Emission Value (dBm) = E (dB μ V/m) - Correction Factor @ 3m.
2. Correction Factor (dB) = $20\log(D) - 104.8$; where D is the measurement distance @ 3m.

Mode	TX channel 23095	Frequency Range	Below 1000 MHz
------	------------------	-----------------	----------------

Antenna Polarity & Test Distance: Horizontal at 3 M

No.	Freq. (MHz)	Reading (dB μ V/m)	Correction Factor (dB)	Emission Value (dBm)	Limit (dBm)	Margin (dB)
1	83.38	27.1	-95.26	-68.16	-13	-55.16
2	148.05	32	-95.26	-63.26	-13	-50.26
3	207.68	29.3	-95.26	-65.96	-13	-52.96
4	302.35	36.4	-95.26	-58.86	-13	-45.86
5	403.06	35.9	-95.26	-59.36	-13	-46.36
6	656.92	36.8	-95.26	-58.46	-13	-45.46

Antenna Polarity & Test Distance: Vertical at 3 M

No.	Freq. (MHz)	Reading (dB μ V/m)	Correction Factor (dB)	Emission Value (dBm)	Limit (dBm)	Margin (dB)
1	81.23	27.2	-95.26	-68.06	-13	-55.06
2	153.57	28.8	-95.26	-66.46	-13	-53.46
3	194.46	32.6	-95.26	-62.66	-13	-49.66
4	300.23	38.4	-95.26	-56.86	-13	-43.86
5	391.46	34.1	-95.26	-61.16	-13	-48.16
6	652.64	36.9	-95.26	-58.36	-13	-45.36

Remarks:

1. Follow ANSI 63.26 section 5.2.7 d), Emission Value (dBm) = E (dB μ V/m) - Correction Factor @ 3m.
2. Correction Factor (dB) = $20\log(D) - 104.8$; where D is the measurement distance @ 3m.

Mode	TX channel 23155	Frequency Range	Below 1000 MHz
------	------------------	-----------------	----------------

Antenna Polarity & Test Distance: Horizontal at 3 M

No.	Freq. (MHz)	Reading (dB μ V/m)	Correction Factor (dB)	Emission Value (dBm)	Limit (dBm)	Margin (dB)
1	66.94	30.8	-95.26	-64.46	-13	-51.46
2	157.74	29.1	-95.26	-66.16	-13	-53.16
3	196.89	32	-95.26	-63.26	-13	-50.26
4	305.65	37	-95.26	-58.26	-13	-45.26
5	392.47	36.8	-95.26	-58.46	-13	-45.46
6	648.86	34.5	-95.26	-60.76	-13	-47.76

Antenna Polarity & Test Distance: Vertical at 3 M

No.	Freq. (MHz)	Reading (dB μ V/m)	Correction Factor (dB)	Emission Value (dBm)	Limit (dBm)	Margin (dB)
1	65.34	28.5	-95.26	-66.76	-13	-53.76
2	153.24	31.5	-95.26	-63.76	-13	-50.76
3	190.91	30.2	-95.26	-65.06	-13	-52.06
4	303.87	38.7	-95.26	-56.56	-13	-43.56
5	394.98	34.7	-95.26	-60.56	-13	-47.56
6	646.21	34.4	-95.26	-60.86	-13	-47.86

Remarks:

1. Follow ANSI 63.26 section 5.2.7 d), Emission Value (dBm) = E (dB μ V/m) - Correction Factor @ 3m.
2. Correction Factor (dB) = $20\log(D) - 104.8$; where D is the measurement distance @ 3m.

LTE Band 12: 10MHz

Mode	TX channel 23060	Frequency Range	Below 1000 MHz
------	------------------	-----------------	----------------

Antenna Polarity & Test Distance: Horizontal at 3 M

No.	Freq. (MHz)	Reading (dB μ V/m)	Correction Factor (dB)	Emission Value (dBm)	Limit (dBm)	Margin (dB)
1	79.47	28.7	-95.26	-66.56	-13	-53.56
2	158.67	29.2	-95.26	-66.06	-13	-53.06
3	196.25	32.8	-95.26	-62.46	-13	-49.46
4	298.64	35.9	-95.26	-59.36	-13	-46.36
5	399.75	34.6	-95.26	-60.66	-13	-47.66
6	649.05	35.1	-95.26	-60.16	-13	-47.16

Antenna Polarity & Test Distance: Vertical at 3 M

No.	Freq. (MHz)	Reading (dB μ V/m)	Correction Factor (dB)	Emission Value (dBm)	Limit (dBm)	Margin (dB)
1	70.18	28.3	-95.26	-66.96	-13	-53.96
2	148.61	31.6	-95.26	-63.66	-13	-50.66
3	205.1	32.4	-95.26	-62.86	-13	-49.86
4	301.56	35	-95.26	-60.26	-13	-47.26
5	393.29	36.2	-95.26	-59.06	-13	-46.06
6	645.76	36.9	-95.26	-58.36	-13	-45.36

Remarks:

1. Follow ANSI 63.26 section 5.2.7 d), Emission Value (dBm) = E (dB μ V/m) - Correction Factor @ 3m.
2. Correction Factor (dB) = $20\log(D) - 104.8$; where D is the measurement distance @ 3m.

Mode	TX channel 23095	Frequency Range	Below 1000 MHz
------	------------------	-----------------	----------------

Antenna Polarity & Test Distance: Horizontal at 3 M

No.	Freq. (MHz)	Reading (dB μ V/m)	Correction Factor (dB)	Emission Value (dBm)	Limit (dBm)	Margin (dB)
1	79.24	30.3	-95.26	-64.96	-13	-51.96
2	151.67	29.2	-95.26	-66.06	-13	-53.06
3	207.69	32.3	-95.26	-62.96	-13	-49.96
4	297.26	35.1	-95.26	-60.16	-13	-47.16
5	406.56	36	-95.26	-59.26	-13	-46.26
6	643.97	37.4	-95.26	-57.86	-13	-44.86

Antenna Polarity & Test Distance: Vertical at 3 M

No.	Freq. (MHz)	Reading (dB μ V/m)	Correction Factor (dB)	Emission Value (dBm)	Limit (dBm)	Margin (dB)
1	71.46	28.6	-95.26	-66.66	-13	-53.66
2	155.62	28.4	-95.26	-66.86	-13	-53.86
3	199.62	32	-95.26	-63.26	-13	-50.26
4	298.08	38.5	-95.26	-56.76	-13	-43.76
5	394.16	33.6	-95.26	-61.66	-13	-48.66
6	640.75	34.4	-95.26	-60.86	-13	-47.86

Remarks:

1. Follow ANSI 63.26 section 5.2.7 d), Emission Value (dBm) = E (dB μ V/m) - Correction Factor @ 3m.
2. Correction Factor (dB) = 20log(D) - 104.8; where D is the measurement distance @ 3m.

Mode	TX channel 23130	Frequency Range	Below 1000 MHz
------	------------------	-----------------	----------------

Antenna Polarity & Test Distance: Horizontal at 3 M

No.	Freq. (MHz)	Reading (dB μ V/m)	Correction Factor (dB)	Emission Value (dBm)	Limit (dBm)	Margin (dB)
1	66.36	30.8	-95.26	-64.46	-13	-51.46
2	143.14	28	-95.26	-67.26	-13	-54.26
3	204.43	30.1	-95.26	-65.16	-13	-52.16
4	295.81	36	-95.26	-59.26	-13	-46.26
5	407.32	36.1	-95.26	-59.16	-13	-46.16
6	643.93	37.5	-95.26	-57.76	-13	-44.76

Antenna Polarity & Test Distance: Vertical at 3 M

No.	Freq. (MHz)	Reading (dB μ V/m)	Correction Factor (dB)	Emission Value (dBm)	Limit (dBm)	Margin (dB)
1	66.58	27.3	-95.26	-67.96	-13	-54.96
2	152.92	30.4	-95.26	-64.86	-13	-51.86
3	196.46	29.1	-95.26	-66.16	-13	-53.16
4	293	36.4	-95.26	-58.86	-13	-45.86
5	394.82	34	-95.26	-61.26	-13	-48.26
6	644.44	37.1	-95.26	-58.16	-13	-45.16

Remarks:

1. Follow ANSI 63.26 section 5.2.7 d), Emission Value (dBm) = E (dB μ V/m) - Correction Factor @ 3m.
2. Correction Factor (dB) = 20log(D) - 104.8; where D is the measurement distance @ 3m.

ABOVE 1GHz

LTE Band 4: 1.4MHz

Mode	TX channel 19957	Frequency Range	Above 1000 MHz
------	------------------	-----------------	----------------

Antenna Polarity & Test Distance: Horizontal at 3 M

No.	Freq. (MHz)	Reading (dB μ V/m)	Correction Factor (dB)	Emission Value (dBm)	Limit (dBm)	Margin (dB)
1	3421.4	37.8	-95.26	-57.46	-13	-44.46
2	5132.1	41.6	-95.26	-53.66	-13	-40.66
3	6842.8	44.2	-95.26	-51.06	-13	-38.06
4	8553.5	47.6	-95.26	-47.66	-13	-34.66

Antenna Polarity & Test Distance: Vertical at 3 M

No.	Freq. (MHz)	Reading (dB μ V/m)	Correction Factor (dB)	Emission Value (dBm)	Limit (dBm)	Margin (dB)
1	3421.4	38.4	-95.26	-56.86	-13	-43.86
2	5132.1	43.4	-95.26	-51.86	-13	-38.86
3	6842.8	47	-95.26	-48.26	-13	-35.26
4	8553.5	47.7	-95.26	-47.56	-13	-34.56

Remarks:

1. Follow ANSI 63.26 section 5.2.7 d), Emission Value (dBm) = E (dB μ V/m) - Correction Factor @ 3m.
2. Correction Factor (dB) = 20log(D) - 104.8; where D is the measurement distance @ 3m.

Mode	TX channel 20175	Frequency Range	Above 1000 MHz
------	------------------	-----------------	----------------

Antenna Polarity & Test Distance: Horizontal at 3 M

No.	Freq. (MHz)	Reading (dB μ V/m)	Correction Factor (dB)	Emission Value (dBm)	Limit (dBm)	Margin (dB)
1	3465	38.4	-95.26	-56.86	-13	-43.86
2	5197.5	42.4	-95.26	-52.86	-13	-39.86
3	6930	47	-95.26	-48.26	-13	-35.26
4	8662.5	46.7	-95.26	-48.56	-13	-35.56

Antenna Polarity & Test Distance: Vertical at 3 M

No.	Freq. (MHz)	Reading (dB μ V/m)	Correction Factor (dB)	Emission Value (dBm)	Limit (dBm)	Margin (dB)
1	3465	38.3	-95.26	-56.96	-13	-43.96
2	5197.5	41.2	-95.26	-54.06	-13	-41.06
3	6930	44.2	-95.26	-51.06	-13	-38.06
4	8662.5	47.4	-95.26	-47.86	-13	-34.86

Remarks:

1. Follow ANSI 63.26 section 5.2.7 d), Emission Value (dBm) = E (dB μ V/m) - Correction Factor @ 3m.
2. Correction Factor (dB) = 20log(D) - 104.8; where D is the measurement distance @ 3m.

Mode	TX channel 20393	Frequency Range	Above 1000 MHz
------	------------------	-----------------	----------------

Antenna Polarity & Test Distance: Horizontal at 3 M

No.	Freq. (MHz)	Reading (dB μ V/m)	Correction Factor (dB)	Emission Value (dBm)	Limit (dBm)	Margin (dB)
1	3508.6	39.4	-95.26	-55.86	-13	-42.86
2	5262.9	42.7	-95.26	-52.56	-13	-39.56
3	7017.2	43.3	-95.26	-51.96	-13	-38.96
4	8771.5	46.6	-95.26	-48.66	-13	-35.66

Antenna Polarity & Test Distance: Vertical at 3 M

No.	Freq. (MHz)	Reading (dB μ V/m)	Correction Factor (dB)	Emission Value (dBm)	Limit (dBm)	Margin (dB)
1	3508.6	39.2	-95.26	-56.06	-13	-43.06
2	5262.9	41.5	-95.26	-53.76	-13	-40.76
3	7017.2	46.8	-95.26	-48.46	-13	-35.46
4	8771.5	47	-95.26	-48.26	-13	-35.26

Remarks:

1. Follow ANSI 63.26 section 5.2.7 d), Emission Value (dBm) = E (dB μ V/m) - Correction Factor @ 3m.
2. Correction Factor (dB) = 20log(D) - 104.8; where D is the measurement distance @ 3m.

LTE Band 4: 3MHz

Mode	TX channel 19965	Frequency Range	Above 1000 MHz
------	------------------	-----------------	----------------

Antenna Polarity & Test Distance: Horizontal at 3 M

No.	Freq. (MHz)	Reading (dB μ V/m)	Correction Factor (dB)	Emission Value (dBm)	Limit (dBm)	Margin (dB)
1	3423	36.5	-95.26	-58.76	-13	-45.76
2	5134.5	41.2	-95.26	-54.06	-13	-41.06
3	6846	45.1	-95.26	-50.16	-13	-37.16
4	8557.5	47.4	-95.26	-47.86	-13	-34.86

Antenna Polarity & Test Distance: Vertical at 3 M

No.	Freq. (MHz)	Reading (dB μ V/m)	Correction Factor (dB)	Emission Value (dBm)	Limit (dBm)	Margin (dB)
1	3423	38.3	-95.26	-56.96	-13	-43.96
2	5134.5	43.3	-95.26	-51.96	-13	-38.96
3	6846	44.1	-95.26	-51.16	-13	-38.16
4	8557.5	47.9	-95.26	-47.36	-13	-34.36

Remarks:

1. Follow ANSI 63.26 section 5.2.7 d), Emission Value (dBm) = E (dB μ V/m) - Correction Factor @ 3m.
2. Correction Factor (dB) = $20\log(D) - 104.8$; where D is the measurement distance @ 3m.

Mode	TX channel 20175	Frequency Range	Above 1000 MHz
------	------------------	-----------------	----------------

Antenna Polarity & Test Distance: Horizontal at 3 M

No.	Freq. (MHz)	Reading (dB μ V/m)	Correction Factor (dB)	Emission Value (dBm)	Limit (dBm)	Margin (dB)
1	3465	36.1	-95.26	-59.16	-13	-46.16
2	5197.5	41.1	-95.26	-54.16	-13	-41.16
3	6930	46.3	-95.26	-48.96	-13	-35.96
4	8662.5	48	-95.26	-47.26	-13	-34.26

Antenna Polarity & Test Distance: Vertical at 3 M

No.	Freq. (MHz)	Reading (dB μ V/m)	Correction Factor (dB)	Emission Value (dBm)	Limit (dBm)	Margin (dB)
1	3465	37.6	-95.26	-57.66	-13	-44.66
2	5197.5	40.2	-95.26	-55.06	-13	-42.06
3	6930	47	-95.26	-48.26	-13	-35.26
4	8662.5	47	-95.26	-48.26	-13	-35.26

Remarks:

1. Follow ANSI 63.26 section 5.2.7 d), Emission Value (dBm) = E (dB μ V/m) - Correction Factor @ 3m.
2. Correction Factor (dB) = 20log(D) - 104.8; where D is the measurement distance @ 3m.

Mode	TX channel 20385	Frequency Range	Above 1000 MHz
------	------------------	-----------------	----------------

Antenna Polarity & Test Distance: Horizontal at 3 M

No.	Freq. (MHz)	Reading (dB μ V/m)	Correction Factor (dB)	Emission Value (dBm)	Limit (dBm)	Margin (dB)
1	3507	38.6	-95.26	-56.66	-13	-43.66
2	5260.5	41.3	-95.26	-53.96	-13	-40.96
3	7014	45	-95.26	-50.26	-13	-37.26
4	8767.5	46.6	-95.26	-48.66	-13	-35.66

Antenna Polarity & Test Distance: Vertical at 3 M

No.	Freq. (MHz)	Reading (dB μ V/m)	Correction Factor (dB)	Emission Value (dBm)	Limit (dBm)	Margin (dB)
1	3507	37.1	-95.26	-58.16	-13	-45.16
2	5260.5	41.1	-95.26	-54.16	-13	-41.16
3	7014	44.2	-95.26	-51.06	-13	-38.06
4	8767.5	47.8	-95.26	-47.46	-13	-34.46

Remarks:

1. Follow ANSI 63.26 section 5.2.7 d), Emission Value (dBm) = E (dB μ V/m) - Correction Factor @ 3m.
2. Correction Factor (dB) = 20log(D) - 104.8; where D is the measurement distance @ 3m.

LTE Band 4: 5MHz

Mode	TX channel 19975	Frequency Range	Above 1000 MHz
------	------------------	-----------------	----------------

Antenna Polarity & Test Distance: Horizontal at 3 M

No.	Freq. (MHz)	Reading (dB μ V/m)	Correction Factor (dB)	Emission Value (dBm)	Limit (dBm)	Margin (dB)
1	3425	39.4	-95.26	-55.86	-13	-42.86
2	5137.5	41.6	-95.26	-53.66	-13	-40.66
3	6850	45.9	-95.26	-49.36	-13	-36.36
4	8562.5	50	-95.26	-45.26	-13	-32.26

Antenna Polarity & Test Distance: Vertical at 3 M

No.	Freq. (MHz)	Reading (dB μ V/m)	Correction Factor (dB)	Emission Value (dBm)	Limit (dBm)	Margin (dB)
1	3425	38.4	-95.26	-56.86	-13	-43.86
2	5137.5	41.7	-95.26	-53.56	-13	-40.56
3	6850	46.1	-95.26	-49.16	-13	-36.16
4	8562.5	47.6	-95.26	-47.66	-13	-34.66

Remarks:

1. Follow ANSI 63.26 section 5.2.7 d), Emission Value (dBm) = E (dB μ V/m) - Correction Factor @ 3m.
2. Correction Factor (dB) = $20\log(D) - 104.8$; where D is the measurement distance @ 3m.

Mode	TX channel 20175	Frequency Range	Above 1000 MHz
------	------------------	-----------------	----------------

Antenna Polarity & Test Distance: Horizontal at 3 M

No.	Freq. (MHz)	Reading (dB μ V/m)	Correction Factor (dB)	Emission Value (dBm)	Limit (dBm)	Margin (dB)
1	3465	39.9	-95.26	-55.36	-13	-42.36
2	5197.5	42.8	-95.26	-52.46	-13	-39.46
3	6930	43.6	-95.26	-51.66	-13	-38.66
4	8662.5	49.8	-95.26	-45.46	-13	-32.46

Antenna Polarity & Test Distance: Vertical at 3 M

No.	Freq. (MHz)	Reading (dB μ V/m)	Correction Factor (dB)	Emission Value (dBm)	Limit (dBm)	Margin (dB)
1	3465	37.3	-95.26	-57.96	-13	-44.96
2	5197.5	41	-95.26	-54.26	-13	-41.26
3	6930	43.3	-95.26	-51.96	-13	-38.96
4	8662.5	48.5	-95.26	-46.76	-13	-33.76

Remarks:

1. Follow ANSI 63.26 section 5.2.7 d), Emission Value (dBm) = E (dB μ V/m) - Correction Factor @ 3m.
2. Correction Factor (dB) = 20log(D) - 104.8; where D is the measurement distance @ 3m.

Mode	TX channel 20375	Frequency Range	Above 1000 MHz
------	------------------	-----------------	----------------

Antenna Polarity & Test Distance: Horizontal at 3 M

No.	Freq. (MHz)	Reading (dB μ V/m)	Correction Factor (dB)	Emission Value (dBm)	Limit (dBm)	Margin (dB)
1	3505	39.4	-95.26	-55.86	-13	-42.86
2	5257.5	43	-95.26	-52.26	-13	-39.26
3	7010	45.9	-95.26	-49.36	-13	-36.36
4	8762.5	47.9	-95.26	-47.36	-13	-34.36

Antenna Polarity & Test Distance: Vertical at 3 M

No.	Freq. (MHz)	Reading (dB μ V/m)	Correction Factor (dB)	Emission Value (dBm)	Limit (dBm)	Margin (dB)
1	3505	38.1	-95.26	-57.16	-13	-44.16
2	5257.5	41.4	-95.26	-53.86	-13	-40.86
3	7010	44	-95.26	-51.26	-13	-38.26
4	8762.5	47.7	-95.26	-47.56	-13	-34.56

Remarks:

1. Follow ANSI 63.26 section 5.2.7 d), Emission Value (dBm) = E (dB μ V/m) - Correction Factor @ 3m.
2. Correction Factor (dB) = 20log(D) - 104.8; where D is the measurement distance @ 3m.

LTE Band 4: 10MHz

Mode	TX channel 20000	Frequency Range	Above 1000 MHz
------	------------------	-----------------	----------------

Antenna Polarity & Test Distance: Horizontal at 3 M

No.	Freq. (MHz)	Reading (dB μ V/m)	Correction Factor (dB)	Emission Value (dBm)	Limit (dBm)	Margin (dB)
1	3430	36.2	-95.26	-59.06	-13	-46.06
2	5145	42.8	-95.26	-52.46	-13	-39.46
3	6860	44.9	-95.26	-50.36	-13	-37.36
4	8575	49.9	-95.26	-45.36	-13	-32.36

Antenna Polarity & Test Distance: Vertical at 3 M

No.	Freq. (MHz)	Reading (dB μ V/m)	Correction Factor (dB)	Emission Value (dBm)	Limit (dBm)	Margin (dB)
1	3430	40	-95.26	-55.26	-13	-42.26
2	5145	40.3	-95.26	-54.96	-13	-41.96
3	6860	45.6	-95.26	-49.66	-13	-36.66
4	8575	48	-95.26	-47.26	-13	-34.26

Remarks:

1. Follow ANSI 63.26 section 5.2.7 d), Emission Value (dBm) = E (dB μ V/m) - Correction Factor @ 3m.
2. Correction Factor (dB) = $20\log(D) - 104.8$; where D is the measurement distance @ 3m.

Mode	TX channel 20175	Frequency Range	Above 1000 MHz
------	------------------	-----------------	----------------

Antenna Polarity & Test Distance: Horizontal at 3 M

No.	Freq. (MHz)	Reading (dB μ V/m)	Correction Factor (dB)	Emission Value (dBm)	Limit (dBm)	Margin (dB)
1	3465	36.3	-95.26	-58.96	-13	-45.96
2	5197.5	42.3	-95.26	-52.96	-13	-39.96
3	6930	46.9	-95.26	-48.36	-13	-35.36
4	8662.5	49.7	-95.26	-45.56	-13	-32.56

Antenna Polarity & Test Distance: Vertical at 3 M

No.	Freq. (MHz)	Reading (dB μ V/m)	Correction Factor (dB)	Emission Value (dBm)	Limit (dBm)	Margin (dB)
1	3465	36.6	-95.26	-58.66	-13	-45.66
2	5197.5	42	-95.26	-53.26	-13	-40.26
3	6930	46.2	-95.26	-49.06	-13	-36.06
4	8662.5	49.2	-95.26	-46.06	-13	-33.06

Remarks:

1. Follow ANSI 63.26 section 5.2.7 d), Emission Value (dBm) = E (dB μ V/m) - Correction Factor @ 3m.
2. Correction Factor (dB) = 20log(D) - 104.8; where D is the measurement distance @ 3m.

Mode	TX channel 20350	Frequency Range	Above 1000 MHz
------	------------------	-----------------	----------------

Antenna Polarity & Test Distance: Horizontal at 3 M

No.	Freq. (MHz)	Reading (dB μ V/m)	Correction Factor (dB)	Emission Value (dBm)	Limit (dBm)	Margin (dB)
1	3500	38	-95.26	-57.26	-13	-44.26
2	5250	41	-95.26	-54.26	-13	-41.26
3	7000	46.2	-95.26	-49.06	-13	-36.06
4	8750	47.9	-95.26	-47.36	-13	-34.36

Antenna Polarity & Test Distance: Vertical at 3 M

No.	Freq. (MHz)	Reading (dB μ V/m)	Correction Factor (dB)	Emission Value (dBm)	Limit (dBm)	Margin (dB)
1	3500	37	-95.26	-58.26	-13	-45.26
2	5250	42.8	-95.26	-52.46	-13	-39.46
3	7000	46.9	-95.26	-48.36	-13	-35.36
4	8750	47.6	-95.26	-47.66	-13	-34.66

Remarks:

1. Follow ANSI 63.26 section 5.2.7 d), Emission Value (dBm) = E (dB μ V/m) - Correction Factor @ 3m.
2. Correction Factor (dB) = 20log(D) - 104.8; where D is the measurement distance @ 3m.

LTE Band 4: 15MHz

Mode	TX channel 20025	Frequency Range	Above 1000 MHz
------	------------------	-----------------	----------------

Antenna Polarity & Test Distance: Horizontal at 3 M

No.	Freq. (MHz)	Reading (dB μ V/m)	Correction Factor (dB)	Emission Value (dBm)	Limit (dBm)	Margin (dB)
1	3435	37.8	-95.26	-57.46	-13	-44.46
2	5152.5	43.6	-95.26	-51.66	-13	-38.66
3	6870	46.3	-95.26	-48.96	-13	-35.96
4	8587.5	46.5	-95.26	-48.76	-13	-35.76

Antenna Polarity & Test Distance: Vertical at 3 M

No.	Freq. (MHz)	Reading (dB μ V/m)	Correction Factor (dB)	Emission Value (dBm)	Limit (dBm)	Margin (dB)
1	3435	39	-95.26	-56.26	-13	-43.26
2	5152.5	41.5	-95.26	-53.76	-13	-40.76
3	6870	44	-95.26	-51.26	-13	-38.26
4	8587.5	49.7	-95.26	-45.56	-13	-32.56

Remarks:

1. Follow ANSI 63.26 section 5.2.7 d), Emission Value (dBm) = E (dB μ V/m) - Correction Factor @ 3m.
2. Correction Factor (dB) = $20\log(D) - 104.8$; where D is the measurement distance @ 3m.

Mode	TX channel 20175	Frequency Range	Above 1000 MHz
------	------------------	-----------------	----------------

Antenna Polarity & Test Distance: Horizontal at 3 M

No.	Freq. (MHz)	Reading (dB μ V/m)	Correction Factor (dB)	Emission Value (dBm)	Limit (dBm)	Margin (dB)
1	3465	36.4	-95.26	-58.86	-13	-45.86
2	5197.5	40.2	-95.26	-55.06	-13	-42.06
3	6930	43.9	-95.26	-51.36	-13	-38.36
4	8662.5	47.6	-95.26	-47.66	-13	-34.66

Antenna Polarity & Test Distance: Vertical at 3 M

No.	Freq. (MHz)	Reading (dB μ V/m)	Correction Factor (dB)	Emission Value (dBm)	Limit (dBm)	Margin (dB)
1	3465	39	-95.26	-56.26	-13	-43.26
2	5197.5	43.3	-95.26	-51.96	-13	-38.96
3	6930	43.2	-95.26	-52.06	-13	-39.06
4	8662.5	49.2	-95.26	-46.06	-13	-33.06

Remarks:

1. Follow ANSI 63.26 section 5.2.7 d), Emission Value (dBm) = E (dB μ V/m) - Correction Factor @ 3m.
2. Correction Factor (dB) = 20log(D) - 104.8; where D is the measurement distance @ 3m.

Mode	TX channel 20325	Frequency Range	Above 1000 MHz
------	------------------	-----------------	----------------

Antenna Polarity & Test Distance: Horizontal at 3 M

No.	Freq. (MHz)	Reading (dB μ V/m)	Correction Factor (dB)	Emission Value (dBm)	Limit (dBm)	Margin (dB)
1	3495	40	-95.26	-55.26	-13	-42.26
2	5242.5	41.1	-95.26	-54.16	-13	-41.16
3	6990	45.8	-95.26	-49.46	-13	-36.46
4	8737.5	48.5	-95.26	-46.76	-13	-33.76

Antenna Polarity & Test Distance: Vertical at 3 M

No.	Freq. (MHz)	Reading (dB μ V/m)	Correction Factor (dB)	Emission Value (dBm)	Limit (dBm)	Margin (dB)
1	3495	38	-95.26	-57.26	-13	-44.26
2	5242.5	41.3	-95.26	-53.96	-13	-40.96
3	6990	43.1	-95.26	-52.16	-13	-39.16
4	8737.5	47	-95.26	-48.26	-13	-35.26

Remarks:

1. Follow ANSI 63.26 section 5.2.7 d), Emission Value (dBm) = E (dB μ V/m) - Correction Factor @ 3m.
2. Correction Factor (dB) = 20log(D) - 104.8; where D is the measurement distance @ 3m.

LTE Band 4: 20MHz

Mode	TX channel 20050	Frequency Range	Above 1000 MHz
------	------------------	-----------------	----------------

Antenna Polarity & Test Distance: Horizontal at 3 M

No.	Freq. (MHz)	Reading (dB μ V/m)	Correction Factor (dB)	Emission Value (dBm)	Limit (dBm)	Margin (dB)
1	3440	39.6	-95.26	-55.66	-13	-42.66
2	5160	42.9	-95.26	-52.36	-13	-39.36
3	6880	45.7	-95.26	-49.56	-13	-36.56
4	8600	48.5	-95.26	-46.76	-13	-33.76

Antenna Polarity & Test Distance: Vertical at 3 M

No.	Freq. (MHz)	Reading (dB μ V/m)	Correction Factor (dB)	Emission Value (dBm)	Limit (dBm)	Margin (dB)
1	3440	36	-95.26	-59.26	-13	-46.26
2	5160	41.9	-95.26	-53.36	-13	-40.36
3	6880	43	-95.26	-52.26	-13	-39.26
4	8600	47.9	-95.26	-47.36	-13	-34.36

Remarks:

1. Follow ANSI 63.26 section 5.2.7 d), Emission Value (dBm) = E (dB μ V/m) - Correction Factor @ 3m.
2. Correction Factor (dB) = $20\log(D) - 104.8$; where D is the measurement distance @ 3m.

Mode	TX channel 20175	Frequency Range	Above 1000 MHz
------	------------------	-----------------	----------------

Antenna Polarity & Test Distance: Horizontal at 3 M

No.	Freq. (MHz)	Reading (dB μ V/m)	Correction Factor (dB)	Emission Value (dBm)	Limit (dBm)	Margin (dB)
1	3465	37.7	-95.26	-57.56	-13	-44.56
2	5197.5	40.8	-95.26	-54.46	-13	-41.46
3	6930	44.8	-95.26	-50.46	-13	-37.46
4	8662.5	48.9	-95.26	-46.36	-13	-33.36

Antenna Polarity & Test Distance: Vertical at 3 M

No.	Freq. (MHz)	Reading (dB μ V/m)	Correction Factor (dB)	Emission Value (dBm)	Limit (dBm)	Margin (dB)
1	3465	39.4	-95.26	-55.86	-13	-42.86
2	5197.5	43.7	-95.26	-51.56	-13	-38.56
3	6930	46.5	-95.26	-48.76	-13	-35.76
4	8662.5	49.1	-95.26	-46.16	-13	-33.16

Remarks:

1. Follow ANSI 63.26 section 5.2.7 d), Emission Value (dBm) = E (dB μ V/m) - Correction Factor @ 3m.
2. Correction Factor (dB) = 20log(D) - 104.8; where D is the measurement distance @ 3m.

Mode	TX channel 20300	Frequency Range	Above 1000 MHz
------	------------------	-----------------	----------------

Antenna Polarity & Test Distance: Horizontal at 3 M

No.	Freq. (MHz)	Reading (dB μ V/m)	Correction Factor (dB)	Emission Value (dBm)	Limit (dBm)	Margin (dB)
1	3490	37.6	-95.26	-57.66	-13	-44.66
2	5235	40.6	-95.26	-54.66	-13	-41.66
3	6980	45.5	-95.26	-49.76	-13	-36.76
4	8725	48.4	-95.26	-46.86	-13	-33.86

Antenna Polarity & Test Distance: Vertical at 3 M

No.	Freq. (MHz)	Reading (dB μ V/m)	Correction Factor (dB)	Emission Value (dBm)	Limit (dBm)	Margin (dB)
1	3490	39.2	-95.26	-56.06	-13	-43.06
2	5235	40.1	-95.26	-55.16	-13	-42.16
3	6980	45.1	-95.26	-50.16	-13	-37.16
4	8725	50.3	-95.26	-44.96	-13	-31.96

Remarks:

1. Follow ANSI 63.26 section 5.2.7 d), Emission Value (dBm) = E (dB μ V/m) - Correction Factor @ 3m.
2. Correction Factor (dB) = 20log(D) - 104.8; where D is the measurement distance @ 3m.

LTE Band 12: 1.4MHz

Mode	TX channel 23017	Frequency Range	Above 1000 MHz
------	------------------	-----------------	----------------

Antenna Polarity & Test Distance: Horizontal at 3 M

No.	Freq. (MHz)	Reading (dB μ V/m)	Correction Factor (dB)	Emission Value (dBm)	Limit (dBm)	Margin (dB)
1	1399.4	32.4	-95.26	-62.86	-13	-49.86
2	2099.1	35.9	-95.26	-59.36	-13	-46.36
3	2798.8	39.6	-95.26	-55.66	-13	-42.66
4	3498.5	38.6	-95.26	-56.66	-13	-43.66

Antenna Polarity & Test Distance: Vertical at 3 M

No.	Freq. (MHz)	Reading (dB μ V/m)	Correction Factor (dB)	Emission Value (dBm)	Limit (dBm)	Margin (dB)
1	1399.4	31.4	-95.26	-63.86	-13	-50.86
2	2099.1	36	-95.26	-59.26	-13	-46.26
3	2798.8	39.6	-95.26	-55.66	-13	-42.66
4	3498.5	40.7	-95.26	-54.56	-13	-41.56

Remarks:

1. Follow ANSI 63.26 section 5.2.7 d), Emission Value (dBm) = E (dB μ V/m) - Correction Factor @ 3m.
2. Correction Factor (dB) = $20\log(D) - 104.8$; where D is the measurement distance @ 3m.

Mode	TX channel 23095	Frequency Range	Above 1000 MHz
------	------------------	-----------------	----------------

Antenna Polarity & Test Distance: Horizontal at 3 M

No.	Freq. (MHz)	Reading (dB μ V/m)	Correction Factor (dB)	Emission Value (dBm)	Limit (dBm)	Margin (dB)
1	1415	33.8	-95.26	-61.46	-13	-48.46
2	2122.5	35.9	-95.26	-59.36	-13	-46.36
3	2830	38.5	-95.26	-56.76	-13	-43.76
4	3537.5	40.9	-95.26	-54.36	-13	-41.36

Antenna Polarity & Test Distance: Vertical at 3 M

No.	Freq. (MHz)	Reading (dB μ V/m)	Correction Factor (dB)	Emission Value (dBm)	Limit (dBm)	Margin (dB)
1	1415	34.4	-95.26	-60.86	-13	-47.86
2	2122.5	34.8	-95.26	-60.46	-13	-47.46
3	2830	38.4	-95.26	-56.86	-13	-43.86
4	3537.5	40.8	-95.26	-54.46	-13	-41.46

Remarks:

1. Follow ANSI 63.26 section 5.2.7 d), Emission Value (dBm) = E (dB μ V/m) - Correction Factor @ 3m.
2. Correction Factor (dB) = 20log(D) - 104.8; where D is the measurement distance @ 3m.

Mode	TX channel 23173	Frequency Range	Above 1000 MHz
------	------------------	-----------------	----------------

Antenna Polarity & Test Distance: Horizontal at 3 M

No.	Freq. (MHz)	Reading (dB μ V/m)	Correction Factor (dB)	Emission Value (dBm)	Limit (dBm)	Margin (dB)
1	1430.6	31.3	-95.26	-63.96	-13	-50.96
2	2145.9	36	-95.26	-59.26	-13	-46.26
3	2861.2	39.5	-95.26	-55.76	-13	-42.76
4	3576.5	40	-95.26	-55.26	-13	-42.26

Antenna Polarity & Test Distance: Vertical at 3 M

No.	Freq. (MHz)	Reading (dB μ V/m)	Correction Factor (dB)	Emission Value (dBm)	Limit (dBm)	Margin (dB)
1	1430.6	32.9	-95.26	-62.36	-13	-49.36
2	2145.9	35.5	-95.26	-59.76	-13	-46.76
3	2861.2	36.1	-95.26	-59.16	-13	-46.16
4	3576.5	40.6	-95.26	-54.66	-13	-41.66

Remarks:

1. Follow ANSI 63.26 section 5.2.7 d), Emission Value (dBm) = E (dB μ V/m) - Correction Factor @ 3m.
2. Correction Factor (dB) = 20log(D) - 104.8; where D is the measurement distance @ 3m.

LTE Band 12: 3MHz

Mode	TX channel 23025	Frequency Range	Above 1000 MHz
------	------------------	-----------------	----------------

Antenna Polarity & Test Distance: Horizontal at 3 M

No.	Freq. (MHz)	Reading (dB μ V/m)	Correction Factor (dB)	Emission Value (dBm)	Limit (dBm)	Margin (dB)
1	1401	34.1	-95.26	-61.16	-13	-48.16
2	2101.5	35.8	-95.26	-59.46	-13	-46.46
3	2802	37.2	-95.26	-58.06	-13	-45.06
4	3502.5	40.1	-95.26	-55.16	-13	-42.16

Antenna Polarity & Test Distance: Vertical at 3 M

No.	Freq. (MHz)	Reading (dB μ V/m)	Correction Factor (dB)	Emission Value (dBm)	Limit (dBm)	Margin (dB)
1	1401	33.4	-95.26	-61.86	-13	-48.86
2	2101.5	34.8	-95.26	-60.46	-13	-47.46
3	2802	38	-95.26	-57.26	-13	-44.26
4	3502.5	40.1	-95.26	-55.16	-13	-42.16

Remarks:

1. Follow ANSI 63.26 section 5.2.7 d), Emission Value (dBm) = E (dB μ V/m) - Correction Factor @ 3m.
2. Correction Factor (dB) = $20\log(D) - 104.8$; where D is the measurement distance @ 3m.

Mode	TX channel 23095	Frequency Range	Above 1000 MHz
------	------------------	-----------------	----------------

Antenna Polarity & Test Distance: Horizontal at 3 M

No.	Freq. (MHz)	Reading (dB μ V/m)	Correction Factor (dB)	Emission Value (dBm)	Limit (dBm)	Margin (dB)
1	1415	31.8	-95.26	-63.46	-13	-50.46
2	2122.5	34.9	-95.26	-60.36	-13	-47.36
3	2830	39.9	-95.26	-55.36	-13	-42.36
4	3537.5	39.1	-95.26	-56.16	-13	-43.16

Antenna Polarity & Test Distance: Vertical at 3 M

No.	Freq. (MHz)	Reading (dB μ V/m)	Correction Factor (dB)	Emission Value (dBm)	Limit (dBm)	Margin (dB)
1	1415	34.5	-95.26	-60.76	-13	-47.76
2	2122.5	34.9	-95.26	-60.36	-13	-47.36
3	2830	36.8	-95.26	-58.46	-13	-45.46
4	3537.5	39.2	-95.26	-56.06	-13	-43.06

Remarks:

1. Follow ANSI 63.26 section 5.2.7 d), Emission Value (dBm) = E (dB μ V/m) - Correction Factor @ 3m.
2. Correction Factor (dB) = 20log(D) - 104.8; where D is the measurement distance @ 3m.

Mode	TX channel 23165	Frequency Range	Above 1000 MHz
------	------------------	-----------------	----------------

Antenna Polarity & Test Distance: Horizontal at 3 M

No.	Freq. (MHz)	Reading (dB μ V/m)	Correction Factor (dB)	Emission Value (dBm)	Limit (dBm)	Margin (dB)
1	1429	34.4	-95.26	-60.86	-13	-47.86
2	2143.5	36.9	-95.26	-58.36	-13	-45.36
3	2858	38.8	-95.26	-56.46	-13	-43.46
4	3572.5	40.3	-95.26	-54.96	-13	-41.96

Antenna Polarity & Test Distance: Vertical at 3 M

No.	Freq. (MHz)	Reading (dB μ V/m)	Correction Factor (dB)	Emission Value (dBm)	Limit (dBm)	Margin (dB)
1	1429	31.1	-95.26	-64.16	-13	-51.16
2	2143.5	37.9	-95.26	-57.36	-13	-44.36
3	2858	38.3	-95.26	-56.96	-13	-43.96
4	3572.5	40	-95.26	-55.26	-13	-42.26

Remarks:

1. Follow ANSI 63.26 section 5.2.7 d), Emission Value (dBm) = E (dB μ V/m) - Correction Factor @ 3m.
2. Correction Factor (dB) = 20log(D) - 104.8; where D is the measurement distance @ 3m.

LTE Band 12: 5MHz

Mode	TX channel 23035	Frequency Range	Above 1000 MHz
------	------------------	-----------------	----------------

Antenna Polarity & Test Distance: Horizontal at 3 M

No.	Freq. (MHz)	Reading (dB μ V/m)	Correction Factor (dB)	Emission Value (dBm)	Limit (dBm)	Margin (dB)
1	1403	34.8	-95.26	-60.46	-13	-47.46
2	2104.5	37.3	-95.26	-57.96	-13	-44.96
3	2806	36.1	-95.26	-59.16	-13	-46.16
4	3507.5	39.2	-95.26	-56.06	-13	-43.06

Antenna Polarity & Test Distance: Vertical at 3 M

No.	Freq. (MHz)	Reading (dB μ V/m)	Correction Factor (dB)	Emission Value (dBm)	Limit (dBm)	Margin (dB)
1	1403	34	-95.26	-61.26	-13	-48.26
2	2104.5	38	-95.26	-57.26	-13	-44.26
3	2806	38	-95.26	-57.26	-13	-44.26
4	3507.5	39.7	-95.26	-55.56	-13	-42.56

Remarks:

1. Follow ANSI 63.26 section 5.2.7 d), Emission Value (dBm) = E (dB μ V/m) - Correction Factor @ 3m.
2. Correction Factor (dB) = $20\log(D) - 104.8$; where D is the measurement distance @ 3m.

Mode	TX channel 23095	Frequency Range	Above 1000 MHz
------	------------------	-----------------	----------------

Antenna Polarity & Test Distance: Horizontal at 3 M

No.	Freq. (MHz)	Reading (dB μ V/m)	Correction Factor (dB)	Emission Value (dBm)	Limit (dBm)	Margin (dB)
1	1415	31.6	-95.26	-63.66	-13	-50.66
2	2122.5	34.5	-95.26	-60.76	-13	-47.76
3	2830	39.6	-95.26	-55.66	-13	-42.66
4	3537.5	41.8	-95.26	-53.46	-13	-40.46

Antenna Polarity & Test Distance: Vertical at 3 M

No.	Freq. (MHz)	Reading (dB μ V/m)	Correction Factor (dB)	Emission Value (dBm)	Limit (dBm)	Margin (dB)
1	1415	31.9	-95.26	-63.36	-13	-50.36
2	2122.5	34.3	-95.26	-60.96	-13	-47.96
3	2830	39.8	-95.26	-55.46	-13	-42.46
4	3537.5	40.5	-95.26	-54.76	-13	-41.76

Remarks:

1. Follow ANSI 63.26 section 5.2.7 d), Emission Value (dBm) = E (dB μ V/m) - Correction Factor @ 3m.
2. Correction Factor (dB) = 20log(D) - 104.8; where D is the measurement distance @ 3m.

Mode	TX channel 23155	Frequency Range	Above 1000 MHz
------	------------------	-----------------	----------------

Antenna Polarity & Test Distance: Horizontal at 3 M

No.	Freq. (MHz)	Reading (dB μ V/m)	Correction Factor (dB)	Emission Value (dBm)	Limit (dBm)	Margin (dB)
1	1427	33.8	-95.26	-61.46	-13	-48.46
2	2140.5	36.1	-95.26	-59.16	-13	-46.16
3	2854	36.8	-95.26	-58.46	-13	-45.46
4	3567.5	40.7	-95.26	-54.56	-13	-41.56

Antenna Polarity & Test Distance: Vertical at 3 M

No.	Freq. (MHz)	Reading (dB μ V/m)	Correction Factor (dB)	Emission Value (dBm)	Limit (dBm)	Margin (dB)
1	1427	32.3	-95.26	-62.96	-13	-49.96
2	2140.5	36.4	-95.26	-58.86	-13	-45.86
3	2854	39	-95.26	-56.26	-13	-43.26
4	3567.5	38.9	-95.26	-56.36	-13	-43.36

Remarks:

1. Follow ANSI 63.26 section 5.2.7 d), Emission Value (dBm) = E (dB μ V/m) - Correction Factor @ 3m.
2. Correction Factor (dB) = 20log(D) - 104.8; where D is the measurement distance @ 3m.

LTE Band 12: 10MHz

Mode	TX channel 23060	Frequency Range	Above 1000 MHz
------	------------------	-----------------	----------------

Antenna Polarity & Test Distance: Horizontal at 3 M

No.	Freq. (MHz)	Reading (dB μ V/m)	Correction Factor (dB)	Emission Value (dBm)	Limit (dBm)	Margin (dB)
1	1408	33.9	-95.26	-61.36	-13	-48.36
2	2112	37.1	-95.26	-58.16	-13	-45.16
3	2816	36.9	-95.26	-58.36	-13	-45.36
4	3520	39.5	-95.26	-55.76	-13	-42.76

Antenna Polarity & Test Distance: Vertical at 3 M

No.	Freq. (MHz)	Reading (dB μ V/m)	Correction Factor (dB)	Emission Value (dBm)	Limit (dBm)	Margin (dB)
1	1408	33.2	-95.26	-62.06	-13	-49.06
2	2112	34	-95.26	-61.26	-13	-48.26
3	2816	38.5	-95.26	-56.76	-13	-43.76
4	3520	40.9	-95.26	-54.36	-13	-41.36

Remarks:

1. Follow ANSI 63.26 section 5.2.7 d), Emission Value (dBm) = E (dB μ V/m) - Correction Factor @ 3m.
2. Correction Factor (dB) = $20\log(D) - 104.8$; where D is the measurement distance @ 3m.

Mode	TX channel 23095	Frequency Range	Above 1000 MHz
------	------------------	-----------------	----------------

Antenna Polarity & Test Distance: Horizontal at 3 M

No.	Freq. (MHz)	Reading (dB μ V/m)	Correction Factor (dB)	Emission Value (dBm)	Limit (dBm)	Margin (dB)
1	1415	34.5	-95.26	-60.76	-13	-47.76
2	2122.5	34.3	-95.26	-60.96	-13	-47.96
3	2830	36.6	-95.26	-58.66	-13	-45.66
4	3537.5	40.3	-95.26	-54.96	-13	-41.96

Antenna Polarity & Test Distance: Vertical at 3 M

No.	Freq. (MHz)	Reading (dB μ V/m)	Correction Factor (dB)	Emission Value (dBm)	Limit (dBm)	Margin (dB)
1	1415	33.9	-95.26	-61.36	-13	-48.36
2	2122.5	37.2	-95.26	-58.06	-13	-45.06
3	2830	38.2	-95.26	-57.06	-13	-44.06
4	3537.5	41.9	-95.26	-53.36	-13	-40.36

Remarks:

1. Follow ANSI 63.26 section 5.2.7 d), Emission Value (dBm) = E (dB μ V/m) - Correction Factor @ 3m.
2. Correction Factor (dB) = 20log(D) - 104.8; where D is the measurement distance @ 3m.

Mode	TX channel 23130	Frequency Range	Above 1000 MHz
------	------------------	-----------------	----------------

Antenna Polarity & Test Distance: Horizontal at 3 M

No.	Freq. (MHz)	Reading (dB μ V/m)	Correction Factor (dB)	Emission Value (dBm)	Limit (dBm)	Margin (dB)
1	1422	34.9	-95.26	-60.36	-13	-47.36
2	2133	34.8	-95.26	-60.46	-13	-47.46
3	2844	38.2	-95.26	-57.06	-13	-44.06
4	3555	39.6	-95.26	-55.66	-13	-42.66

Antenna Polarity & Test Distance: Vertical at 3 M

No.	Freq. (MHz)	Reading (dB μ V/m)	Correction Factor (dB)	Emission Value (dBm)	Limit (dBm)	Margin (dB)
1	1422	32.4	-95.26	-62.86	-13	-49.86
2	2133	35.8	-95.26	-59.46	-13	-46.46
3	2844	37.5	-95.26	-57.76	-13	-44.76
4	3555	40.5	-95.26	-54.76	-13	-41.76

Remarks:

1. Follow ANSI 63.26 section 5.2.7 d), Emission Value (dBm) = E (dB μ V/m) - Correction Factor @ 3m.
2. Correction Factor (dB) = 20log(D) - 104.8; where D is the measurement distance @ 3m.

5 Pictures of Test Arrangements

Please refer to the attached file (Test Setup Photo).

Appendix – Information of the Testing Laboratories

We, Bureau Veritas Consumer Products Services (H.K.) Ltd., Taoyuan Branch, were founded in 1988 to provide our best service in EMC, Radio, Telecom and Safety consultation. Our laboratories are accredited and approved according to ISO/IEC 17025.

If you have any comments, please feel free to contact us at the following:

Lin Kou EMC/RF Lab

Tel: 886-2-26052180

Fax: 886-2-26051924

Hsin Chu EMC/RF Lab/Telecom Lab

Tel: 886-3-6668565

Fax: 886-3-6668323

Hwa Ya EMC/RF/Safety

Tel: 886-3-3183232

Fax: 886-3-3270892

Email: service.adt@tw.bureauveritas.com

Web Site: www.bureauveritas-adt.com

The address and road map of all our labs can be found in our web site also.

--- END ---