

AWAN

AT150E-US DVT2 WiFi/BT

Test Report

New Technology & Research

The Reliable industry high performance standard for Antennas

www.awan-ant.com



- **Antenna Testing Conditions**

1. Test System

2. Antenna Under Test

3. Antenna Placement

- **Antenna RF characteristics**

1. VSWR & Gain Table

2. Radiation Patterns

2. Isolation

Antenna Test System

Test setup

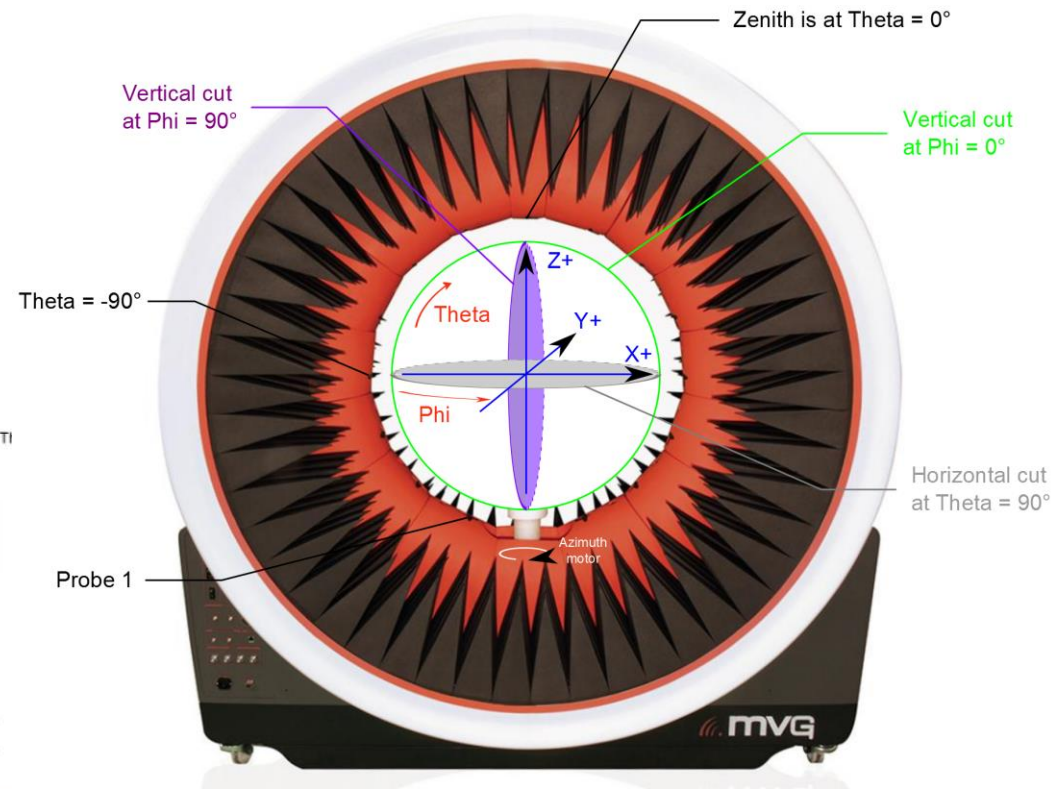
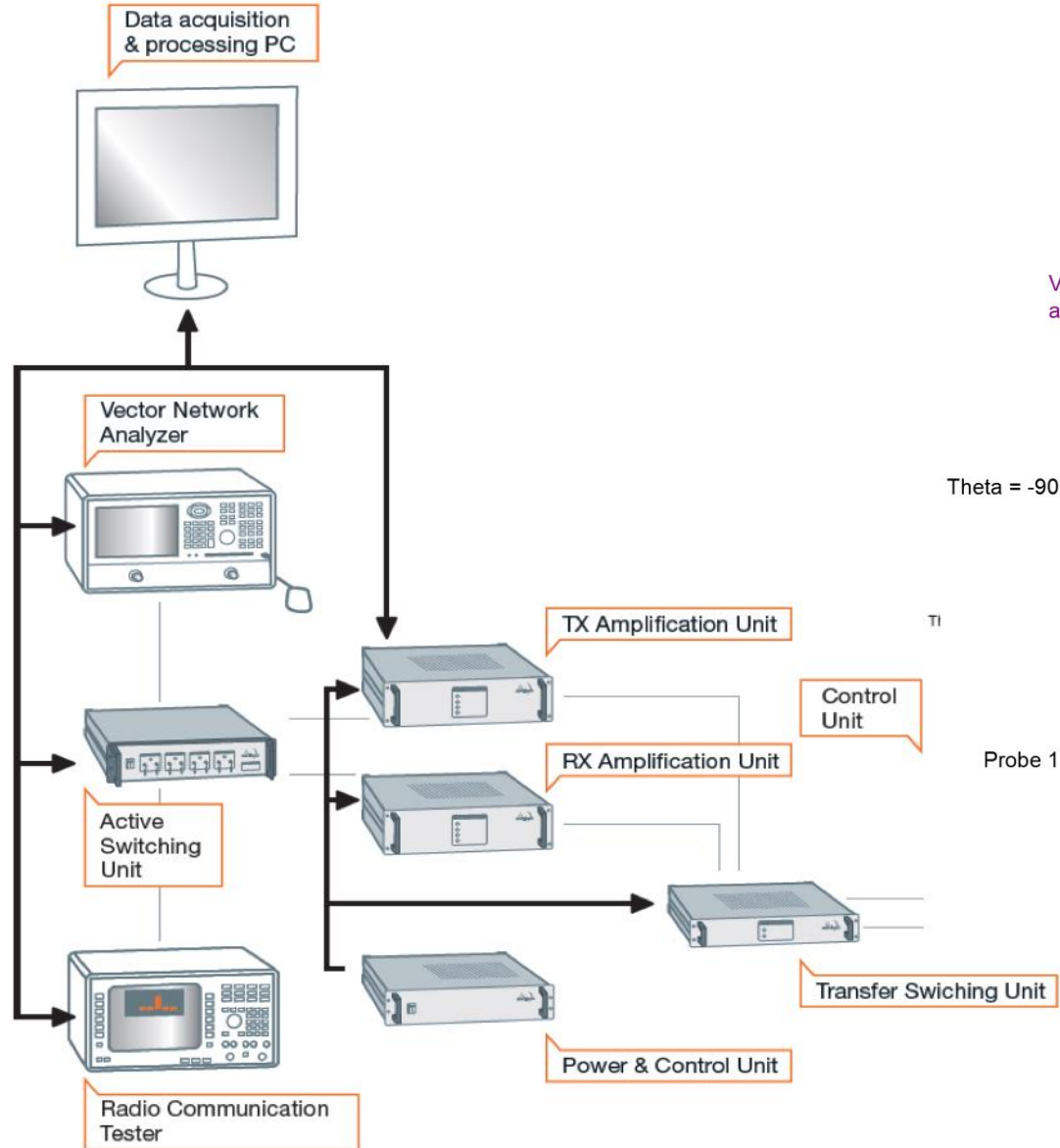

Antenna Test System

Test Equipment

Equipment Description	Manufacturer	Identification no.	Current Calibration date	Next calibration date
Universal Radio Communication tester	Anritsu	MT8820C	2022/07/29	2022/12/29
Network Analyzer	Agilent	E5071C	2022/07/29	2022/12/29
Sleeve Dipole	MVG	SD740	2022/07/12	2022/12/12
Dual Ridge Horn	MVG	SH800	2022/07/12	2022/12/12
Dipole antenna	MVG	3126-700	2022/07/12	2022/12/12
Stargate-16-L probe array	MVG	Stargate-16-L	2022/07/12	2022/12/12
Measurement software	MVG	Wave Studio 22.1	N/A	N/A
Wireless protocol tester	R&S	CMW500	2022/07/29	2022/12/29

Antenna Under Test

WiFi/BT

Antenna Model	AYF6P-100002	
Antenna Type	PIFA Antenna for WiFi application	
Connector Material	I-PEX MHF1	
Cable Type	Ø1.13	
Polarization	Linear	
Impedance	50Ω	
Radiation pattern	Omni-directional	
Frequency	2400~2500MHz	5150~5850MHz
VSWR	2.0 Max	2.0 Max
Peak gain(dBi)	2.35~2.59	3.43~4.47
Antenna dimension	WiFi(AYF6P-100002)	Figure-1

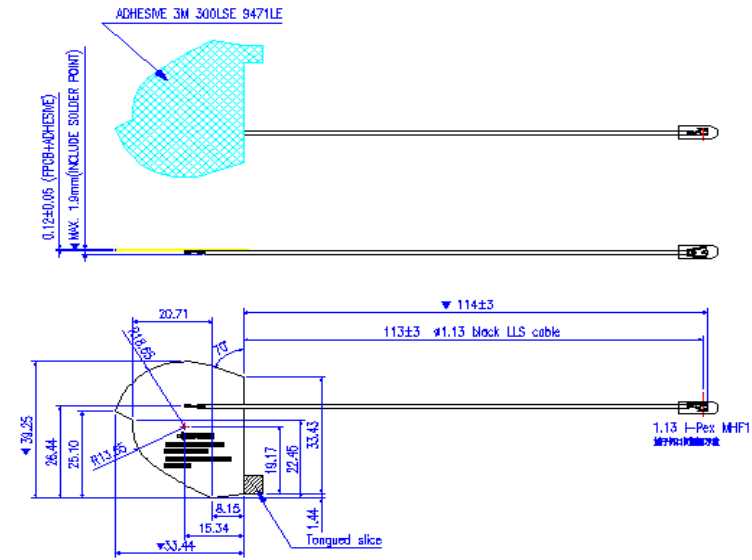
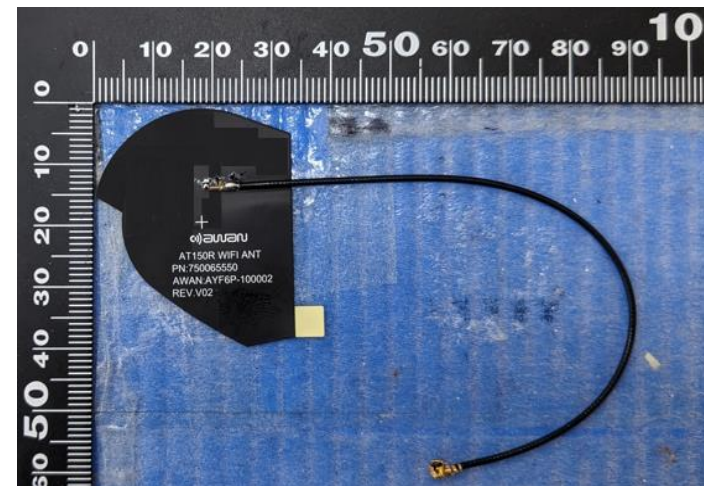
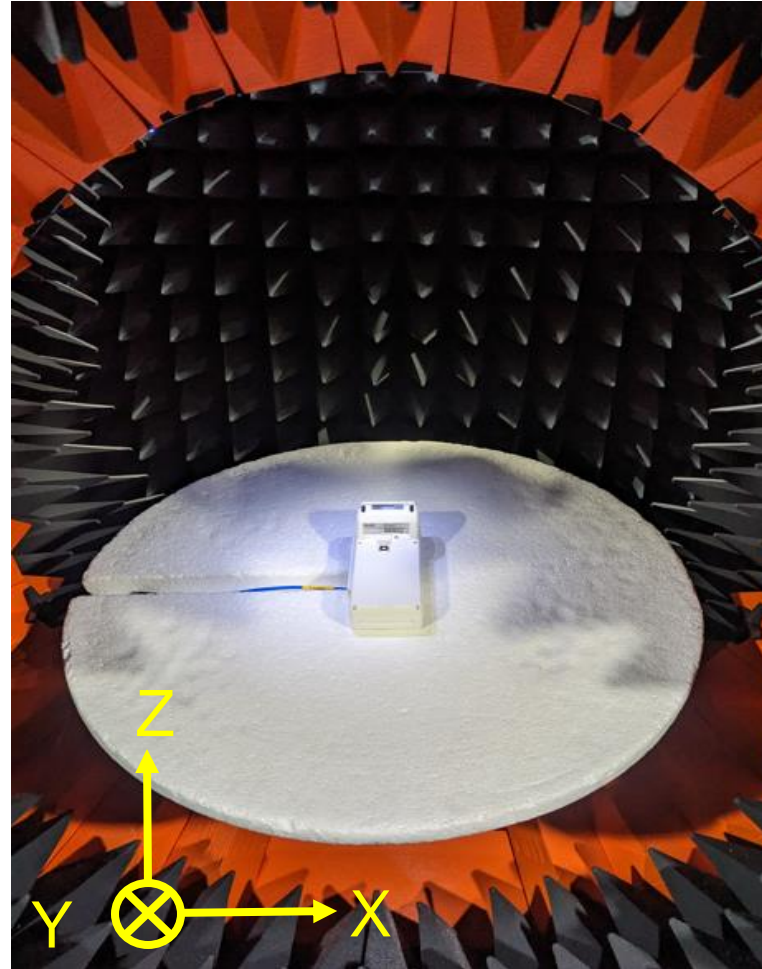

Figure-1 AYF6P-100002



Antenna Under Test

Setup photo



Description	Tester	Measured Date
Measured	William.Lee	2023/04/27

The antenna gain values are used in EMC measurement, the EIRP and/or Conducted power are compliance all FCC requirements and not exceed the limit.

Antenna Placement

WiFi/BT



LTE Main Antenna

LTE Aux Antenna

WiFi/BT



VSWR & Gain Table_WiFi/BT

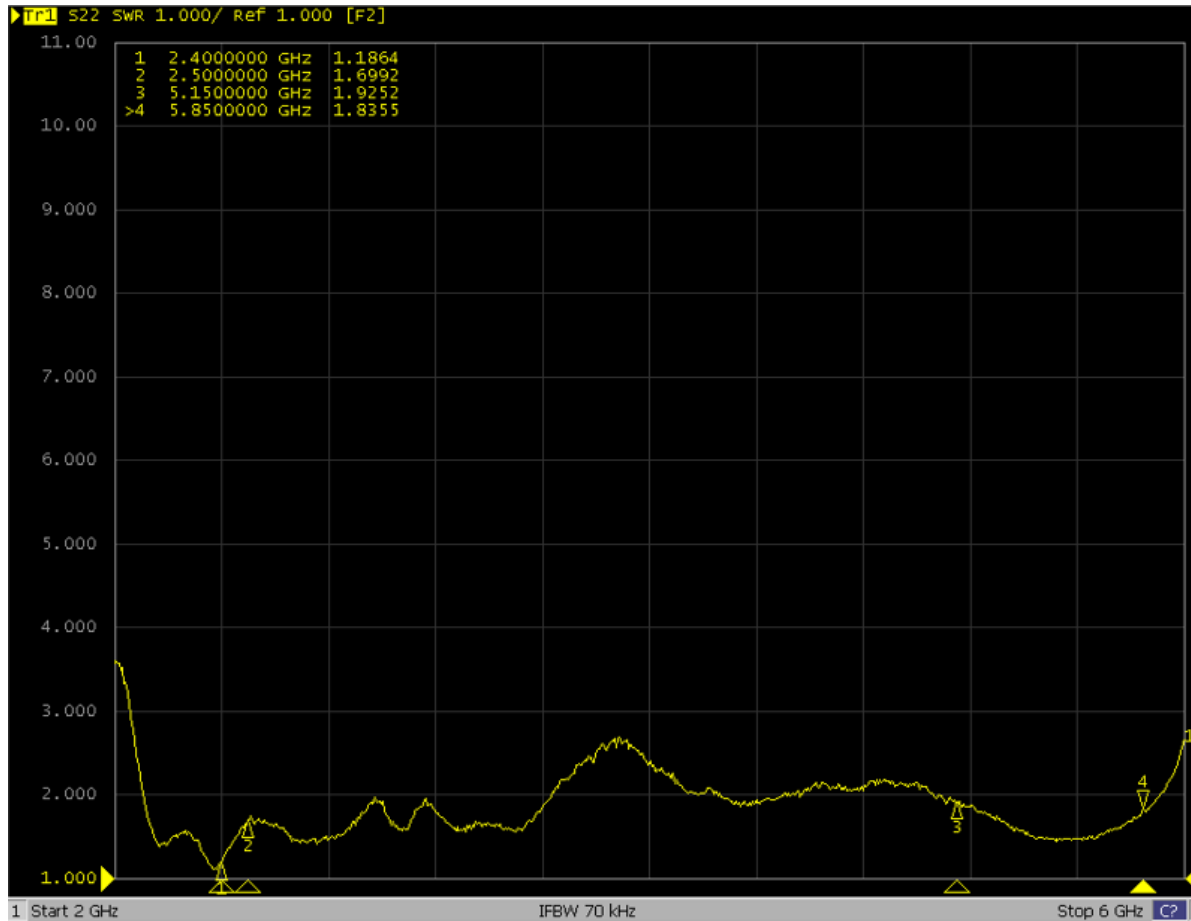

Frequency (MHz)	3D Avg. Gain(dBi)	3D Peak Gain (dBi)	Efficiency(%)
2400	-3.37	2.35	46.03
2450	-3.35	2.47	46.24
2500	-3.45	2.59	45.19
5150	-3.28	4.07	46.99
5250	-3.21	4.24	47.75
5350	-3.33	4.47	46.45
5470	-3.00	4.17	50.12
5725	-3.37	3.73	46.03
5785	-3.11	3.51	48.87
5850	-3.54	3.43	44.26

Radiation Patterns_WiFi/BT_2400MHz

3D	ZY-Plane
ZX-Plane	XY-Plane

dB	ZY Plane	ZX Plane	XY Plane
Total(Max.)	1.88	0.28	2.32

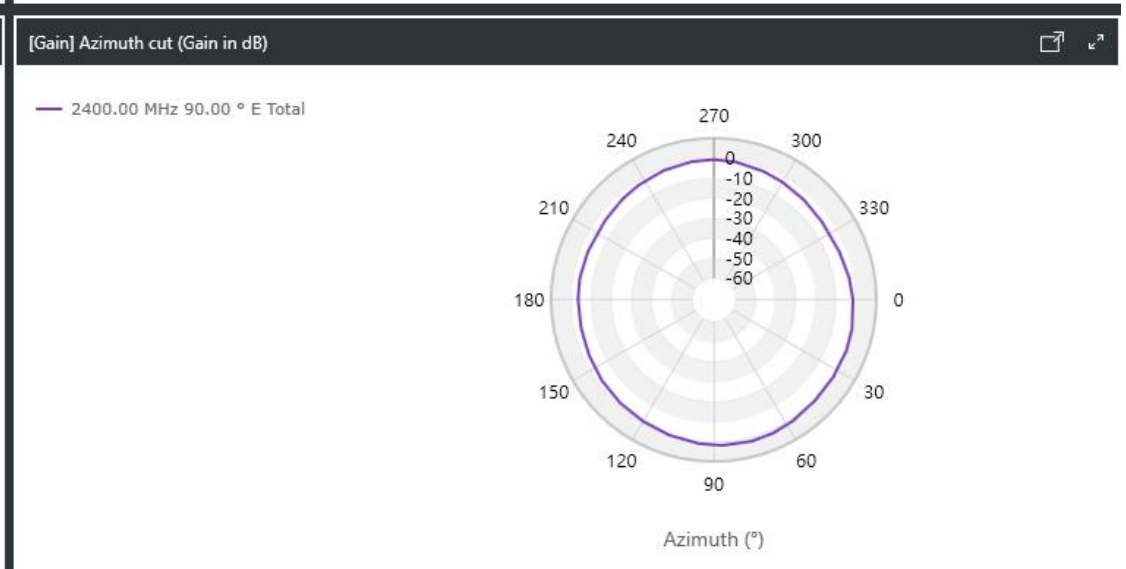
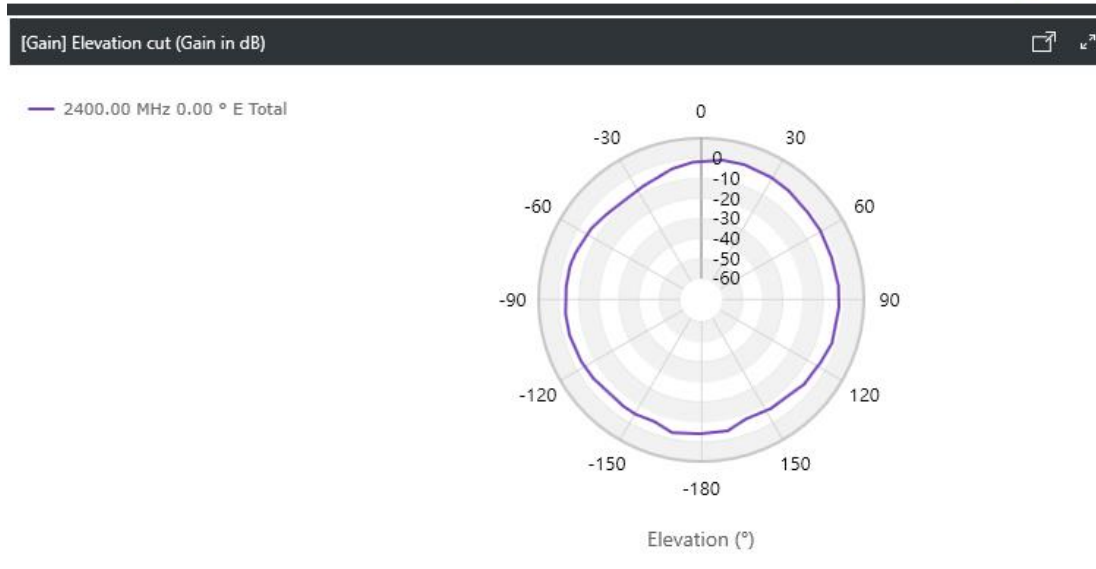
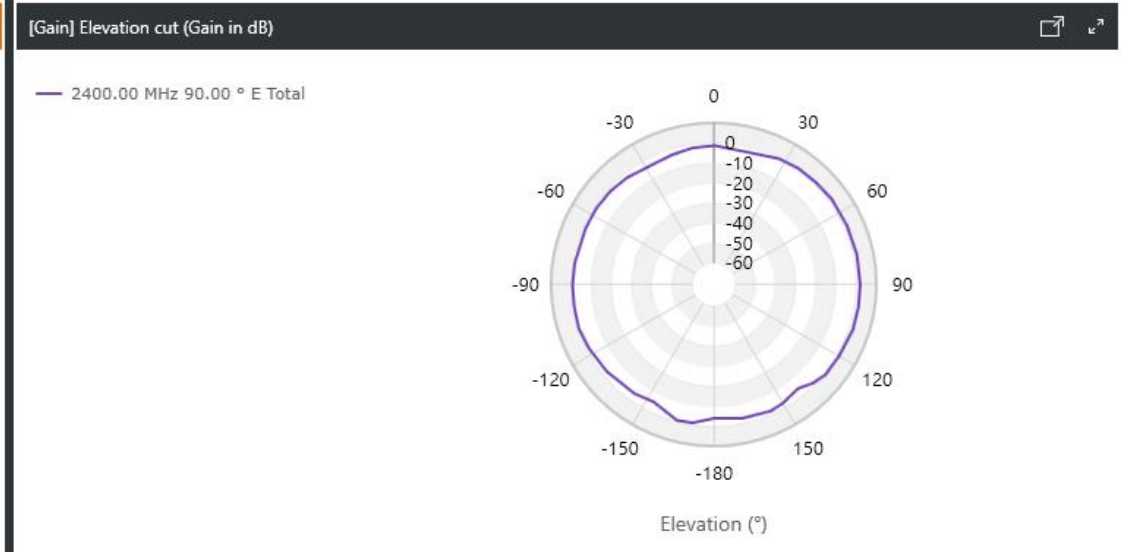
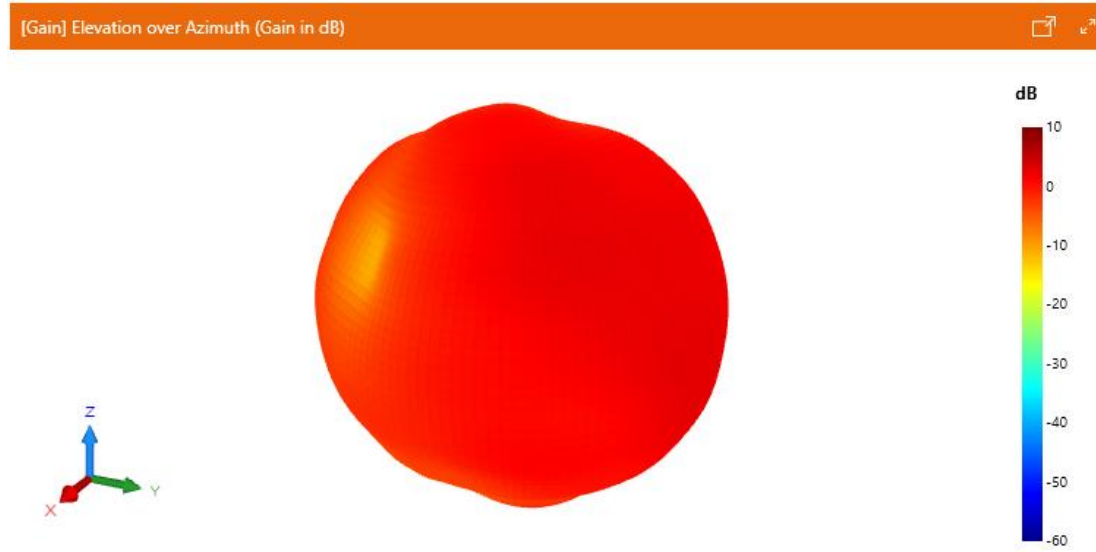

Radiation Patterns_WiFi/BT_2450MHz

3D	ZY-Plane
ZX-Plane	XY-Plane

dB	ZY Plane	ZX Plane	XY Plane
Total(Max.)	2.09	-0.33	2.47

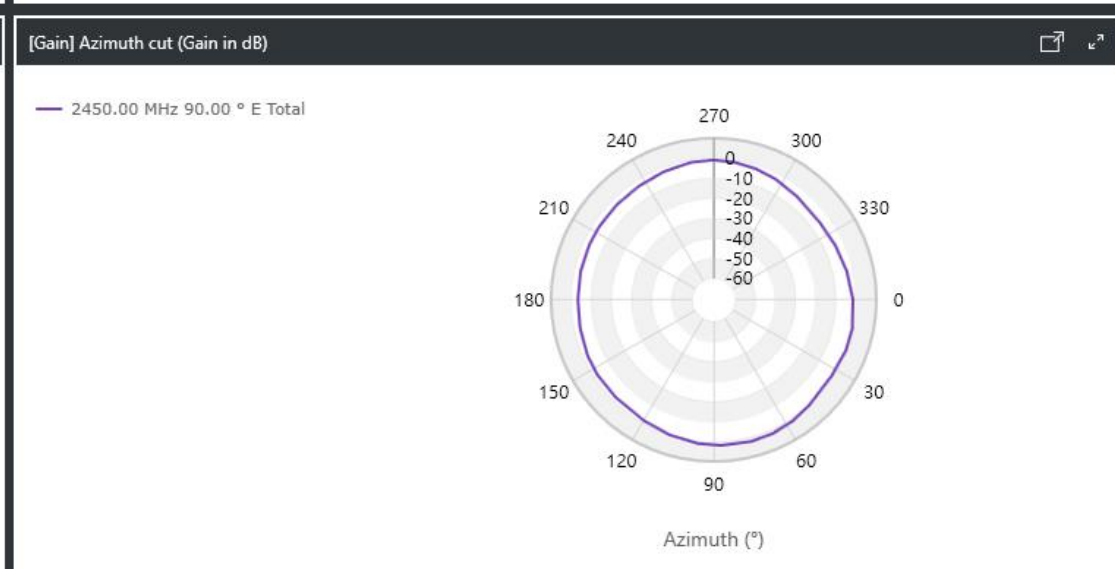
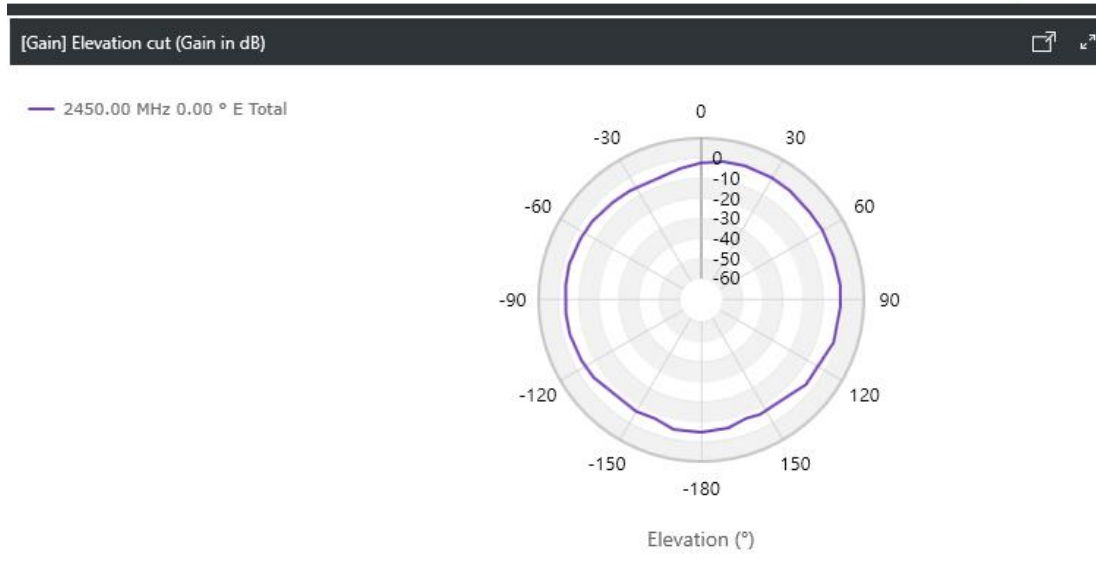
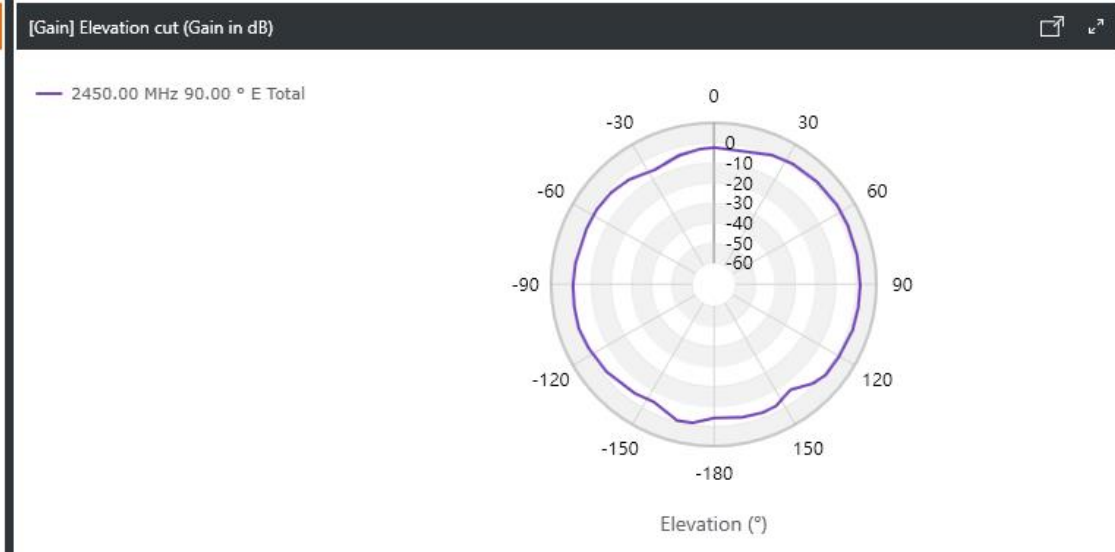
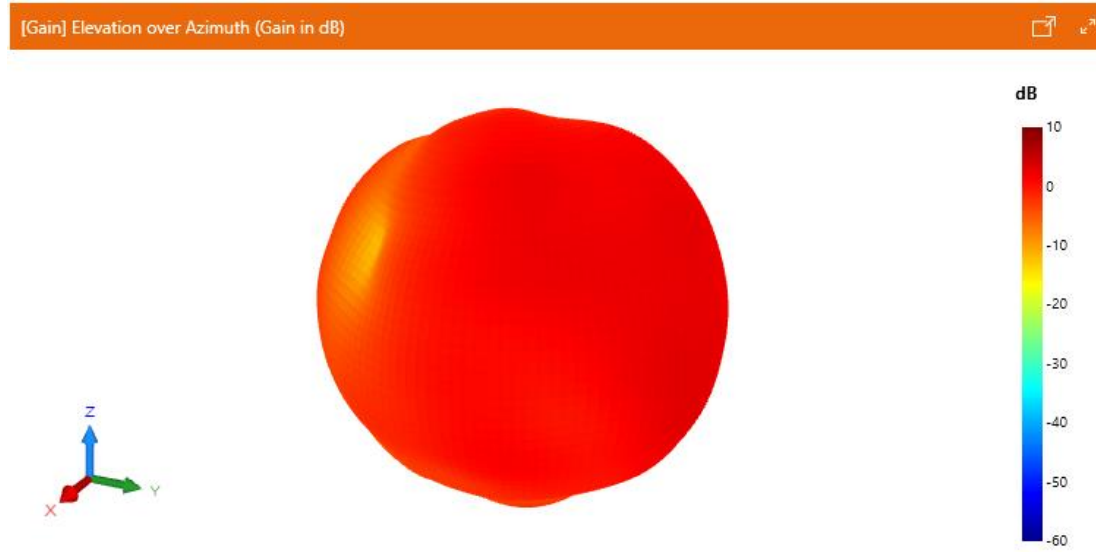

Radiation Patterns_WiFi/BT_2500MHz

3D	ZY-Plane
ZX-Plane	XY-Plane

dB	ZY Plane	ZX Plane	XY Plane
Total(Max.)	2.48	0.16	2.48

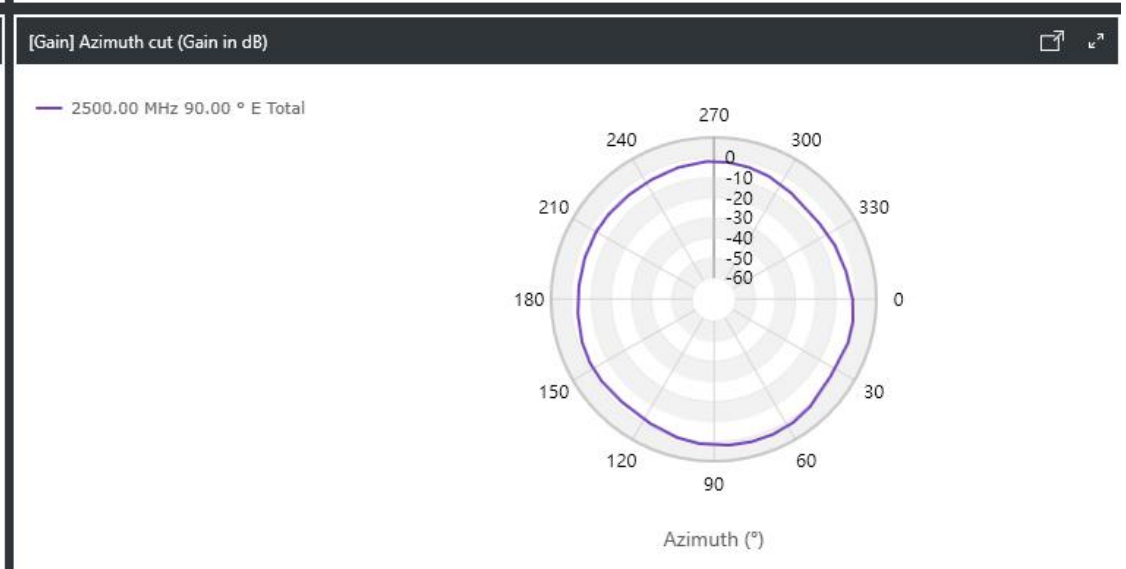
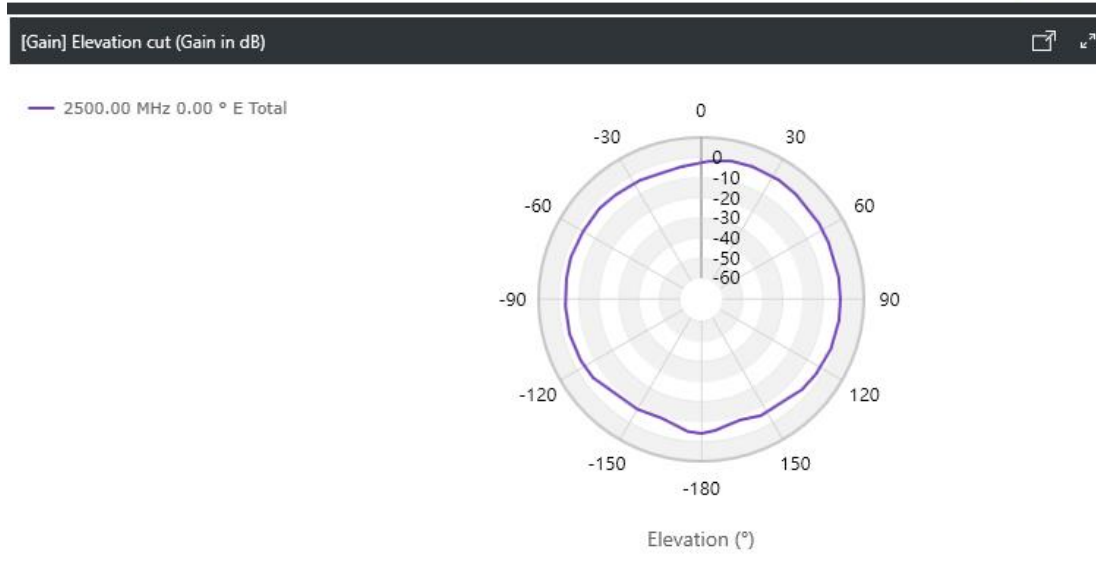
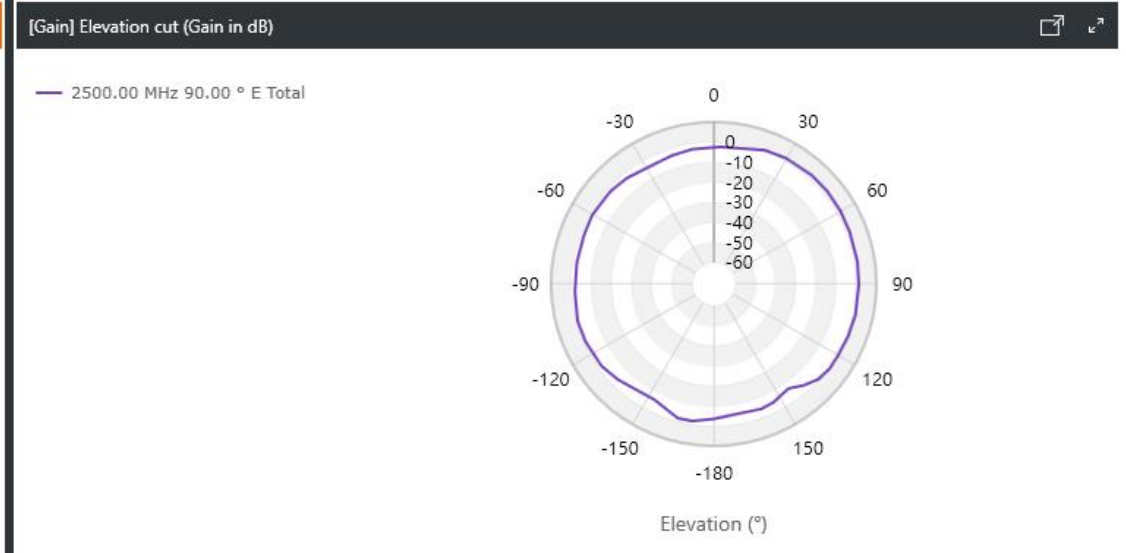
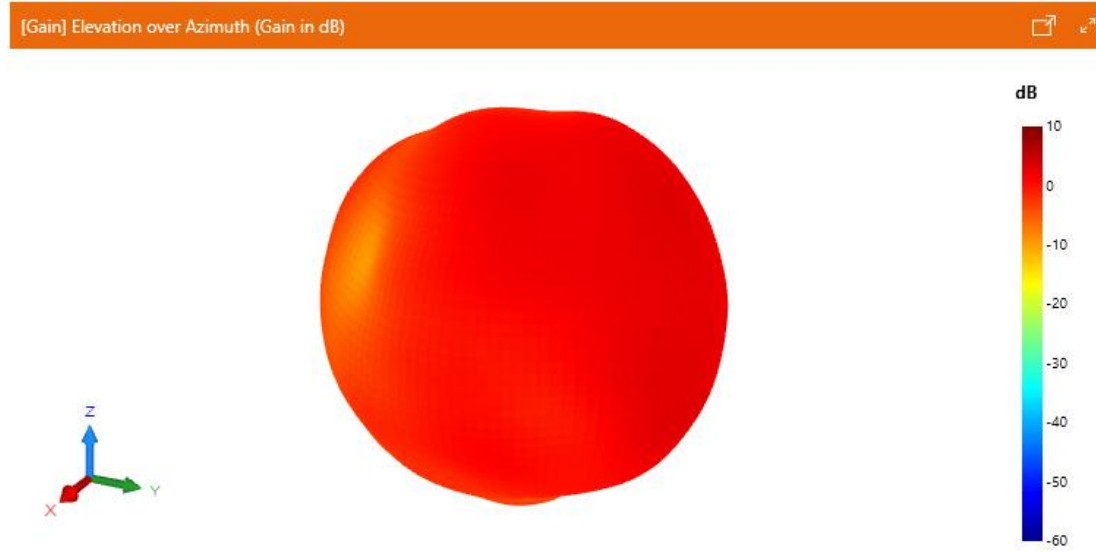

Radiation Patterns_WiFi/BT_5150MHz

3D	ZY-Plane
ZX-Plane	XY-Plane

dB	ZY Plane	ZX Plane	XY Plane
Total(Max.)	2.09	1.21	2.33

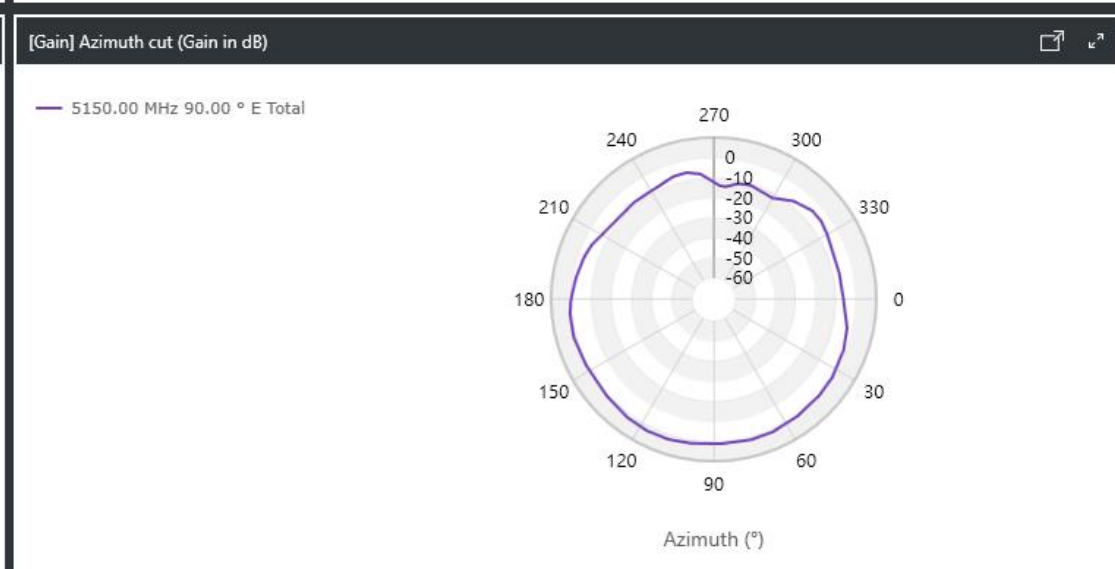
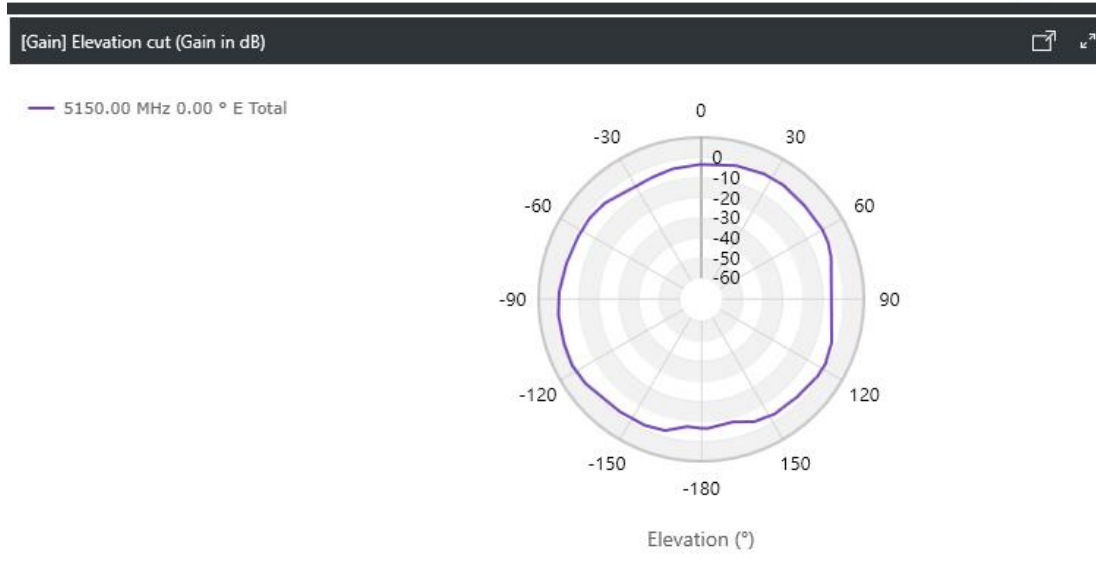
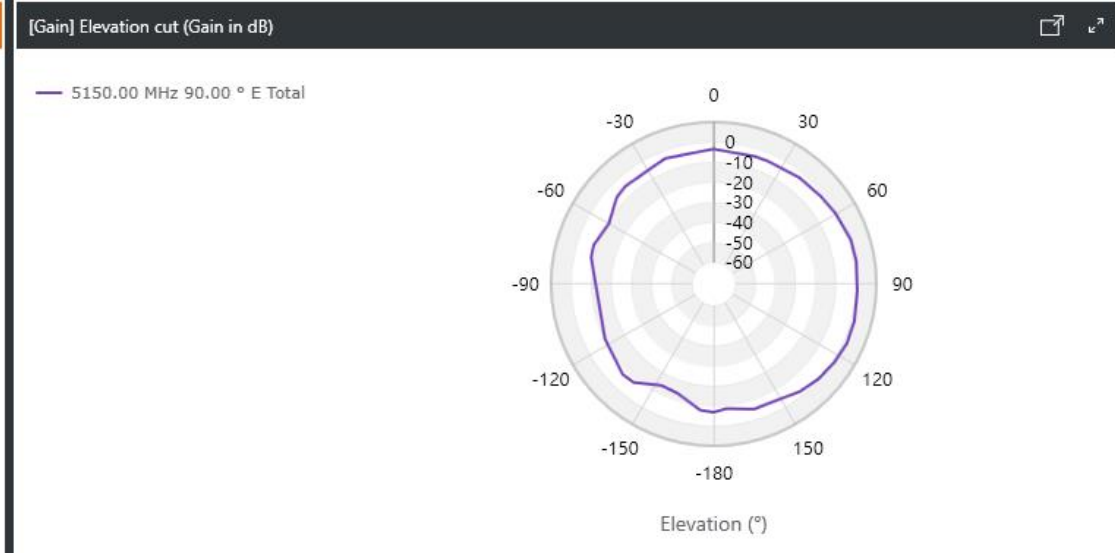
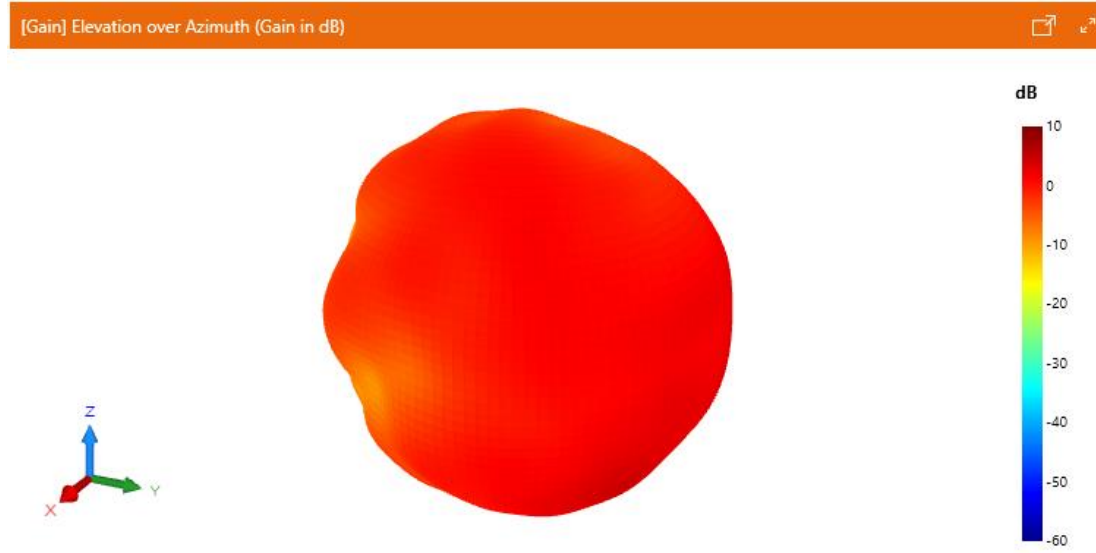

Radiation Patterns_WiFi/BT_5250MHz

3D	ZY-Plane
ZX-Plane	XY-Plane

dB	ZY Plane	ZX Plane	XY Plane
Total(Max.)	2.38	1.96	2.19

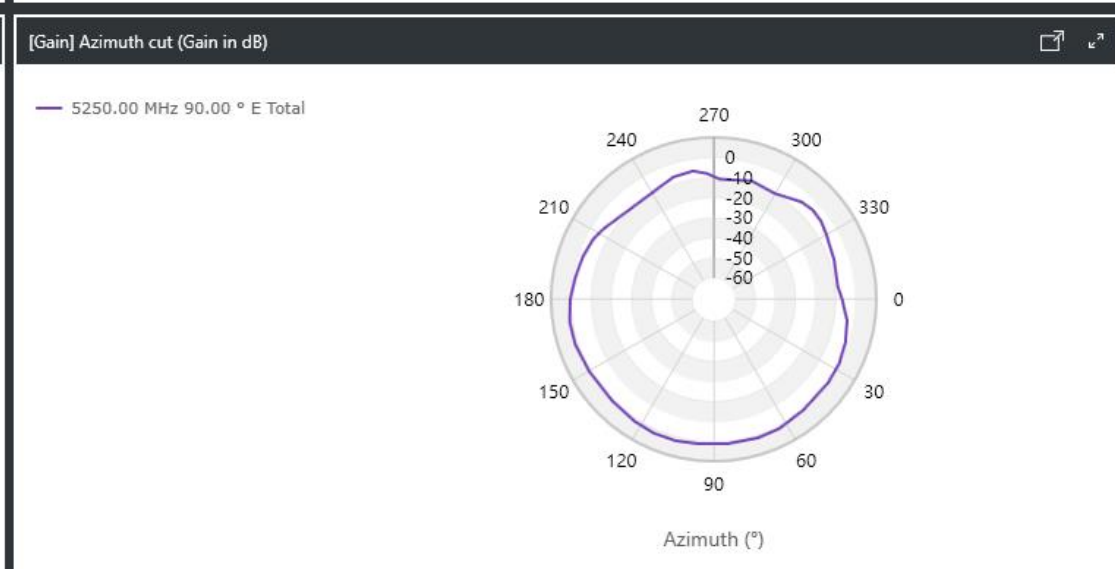
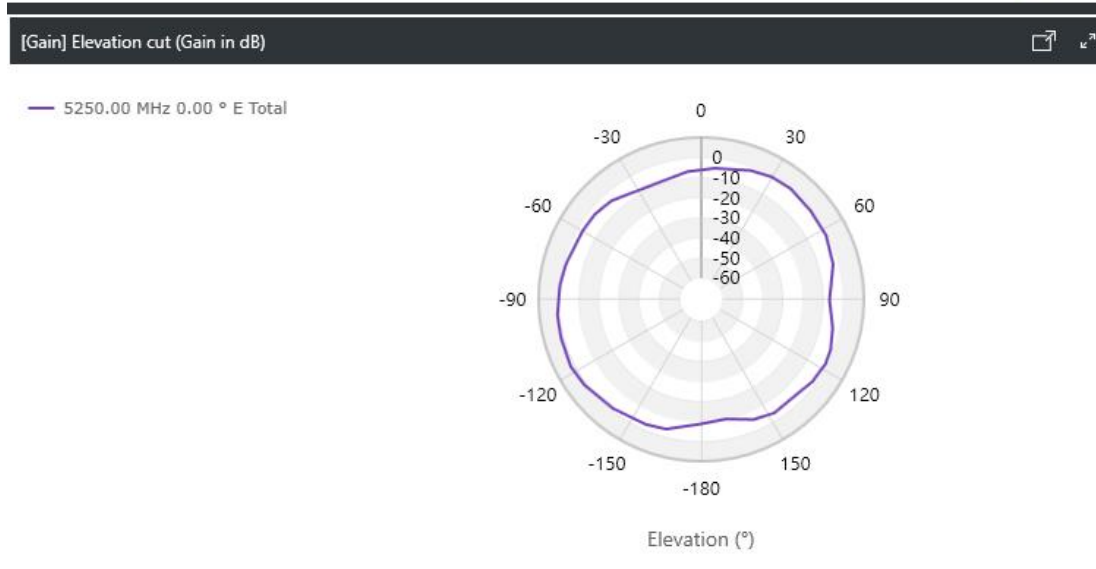
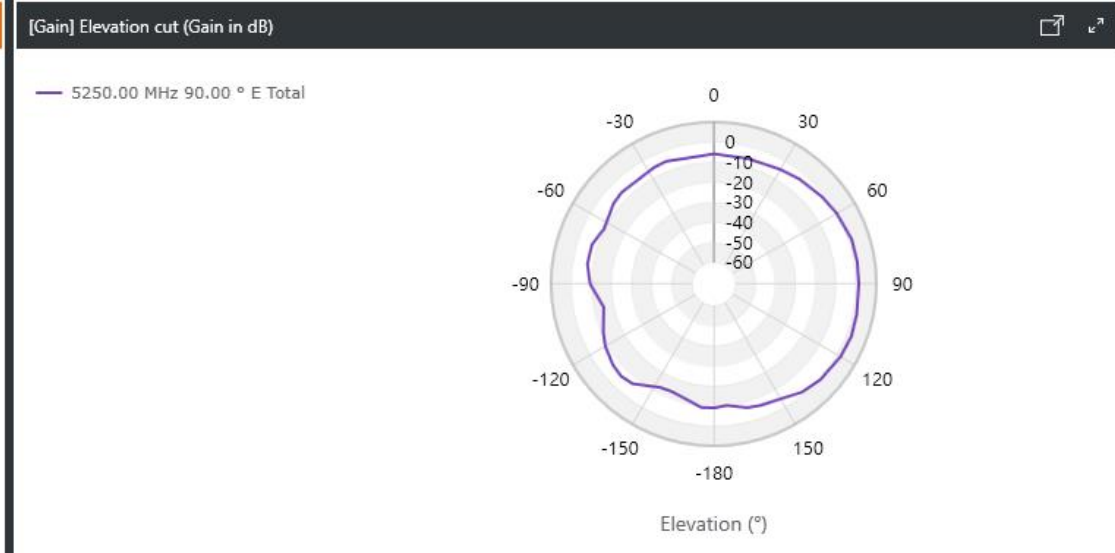
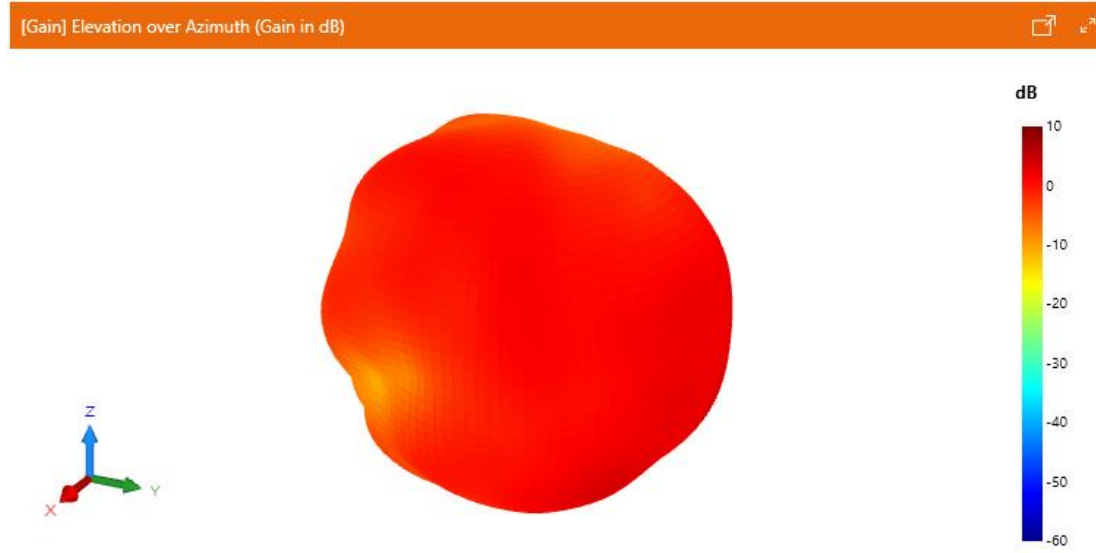

Radiation Patterns_WiFi/BT_5350MHz

3D	ZY-Plane
ZX-Plane	XY-Plane

dB	ZY Plane	ZX Plane	XY Plane
Total(Max.)	3.02	2.45	2.35

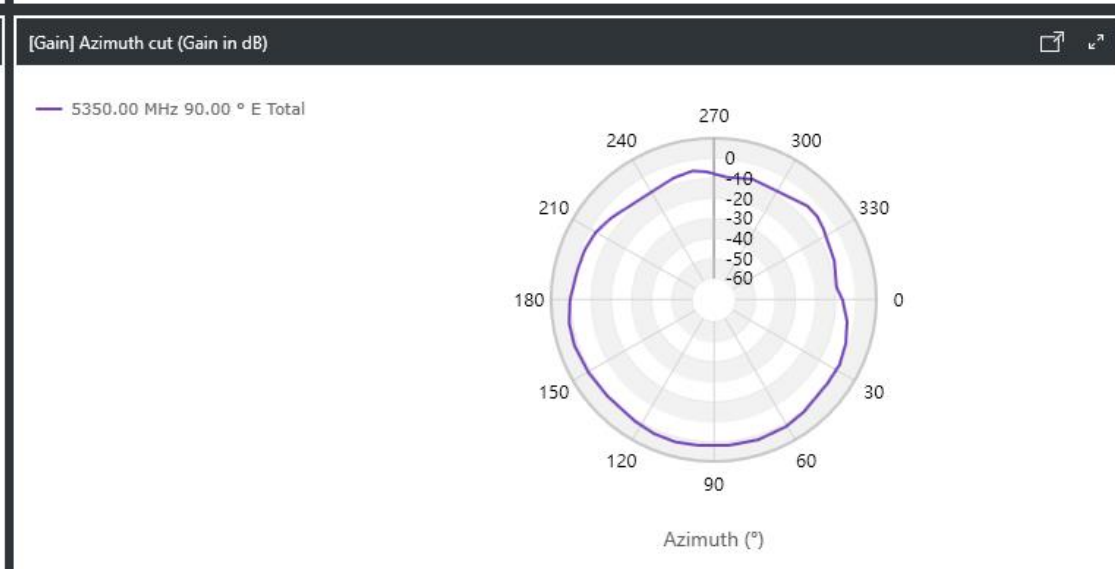
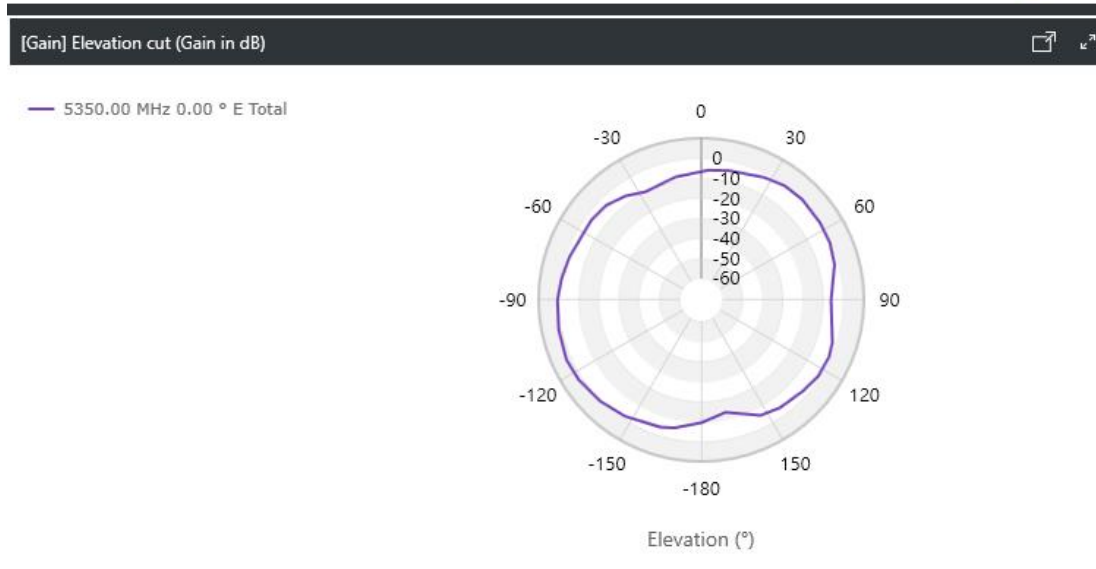
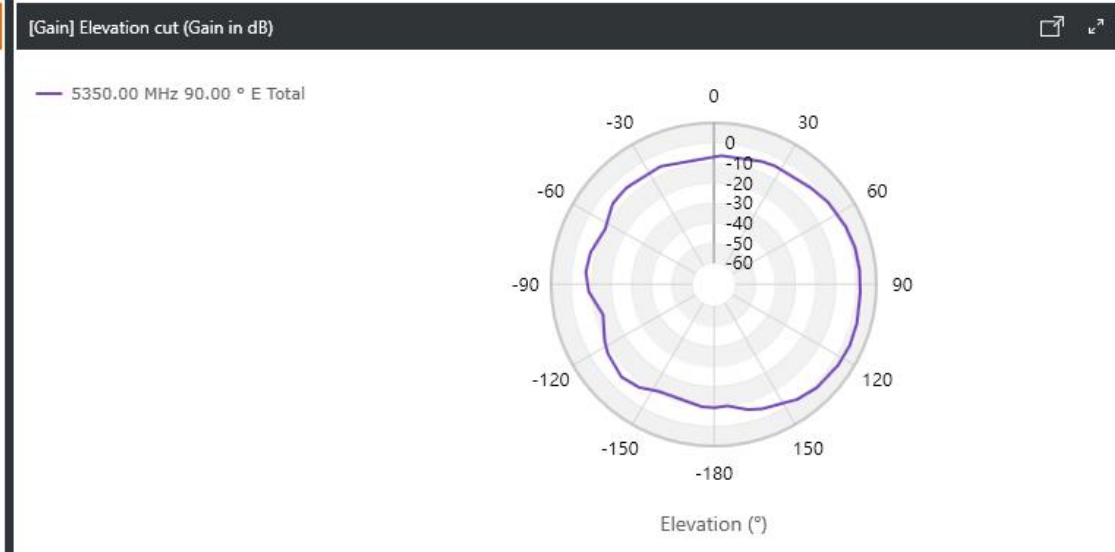
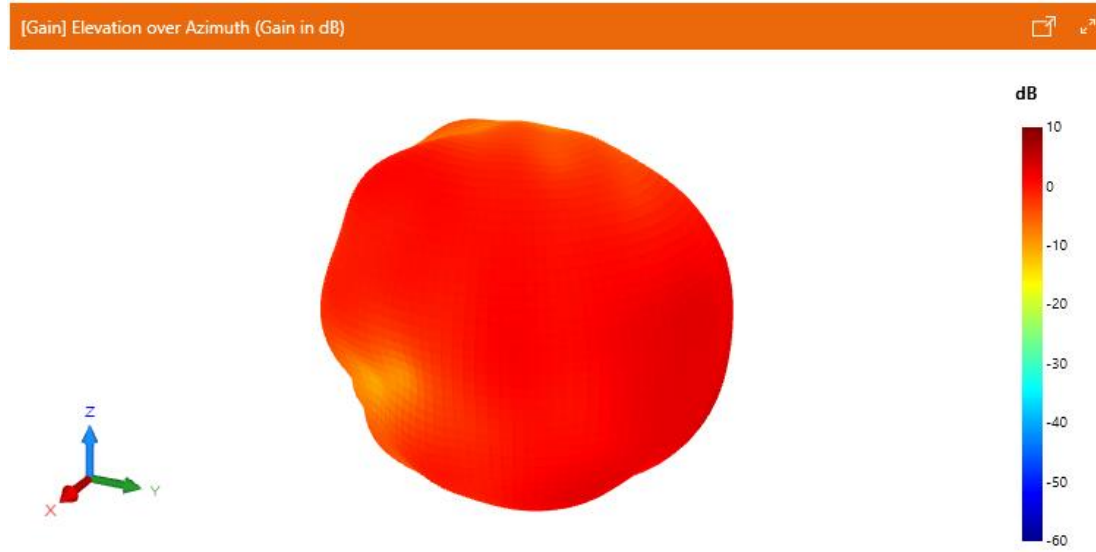

Radiation Patterns_WiFi/BT_5470MHz

3D	ZY-Plane
ZX-Plane	XY-Plane

dB	ZY Plane	ZX Plane	XY Plane
Total(Max.)	3.43	2.60	3.17

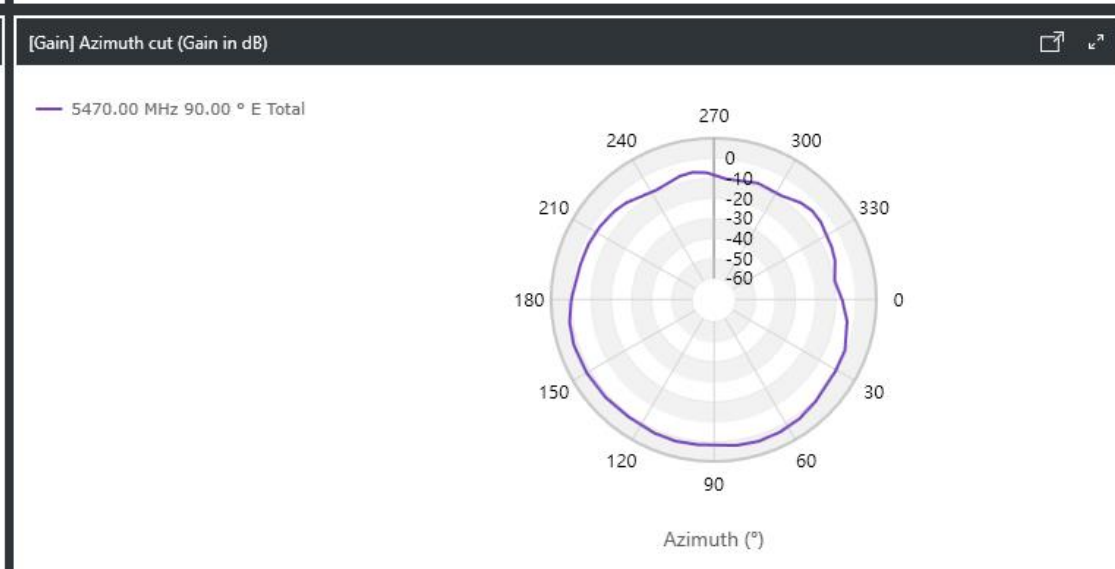
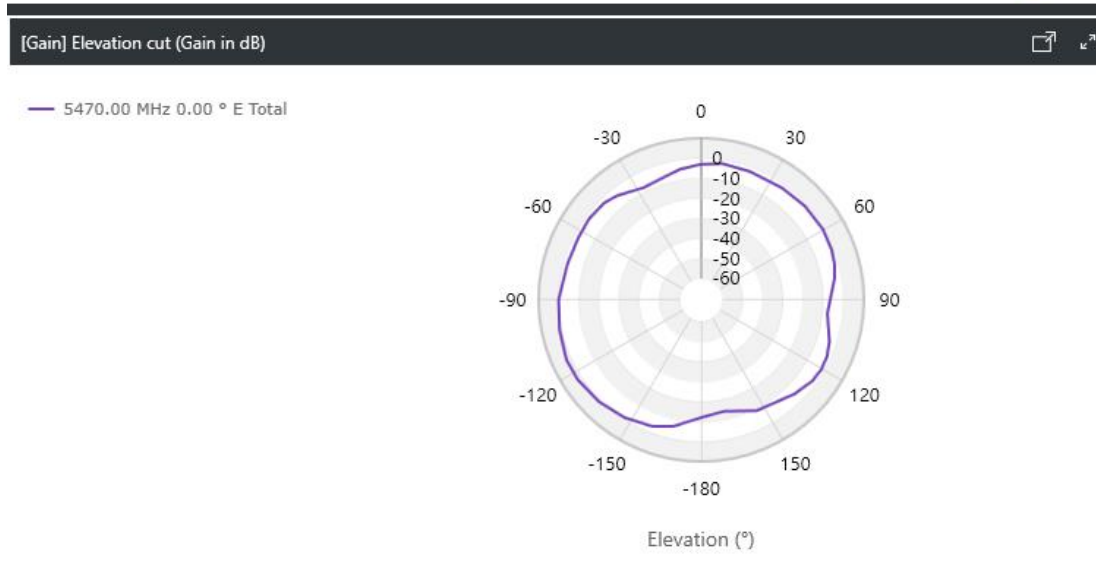
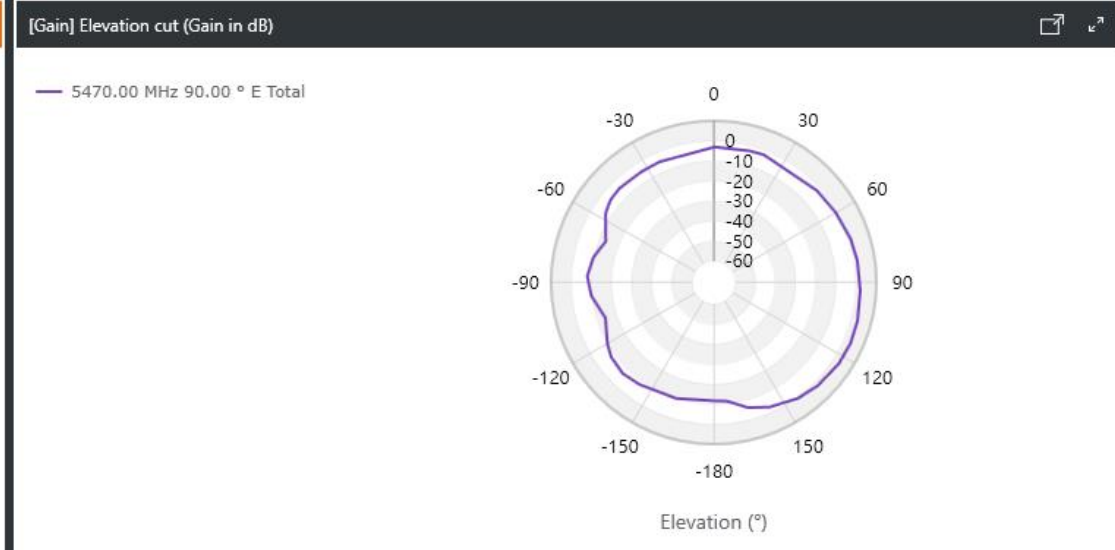
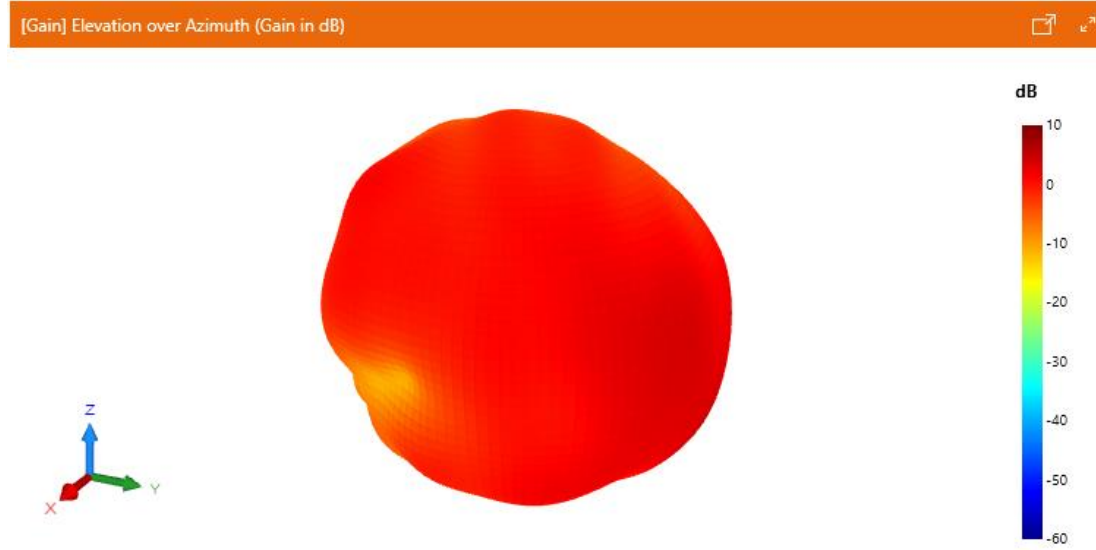

Radiation Patterns_WiFi/BT_5725MHz

3D	ZY-Plane
ZX-Plane	XY-Plane

dB	ZY Plane	ZX Plane	XY Plane
Total(Max.)	2.78	1.51	2.63

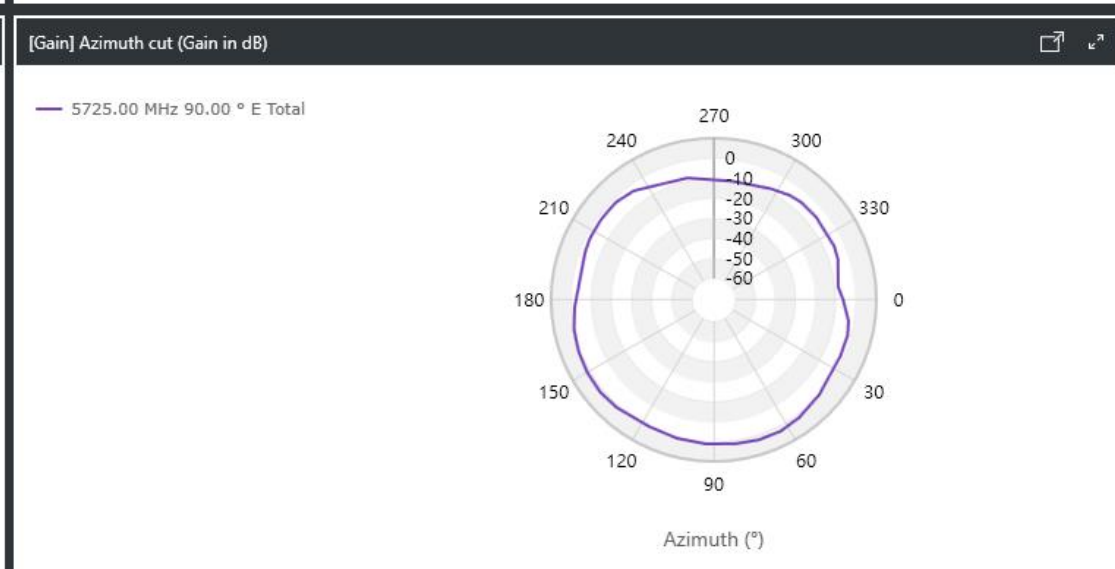
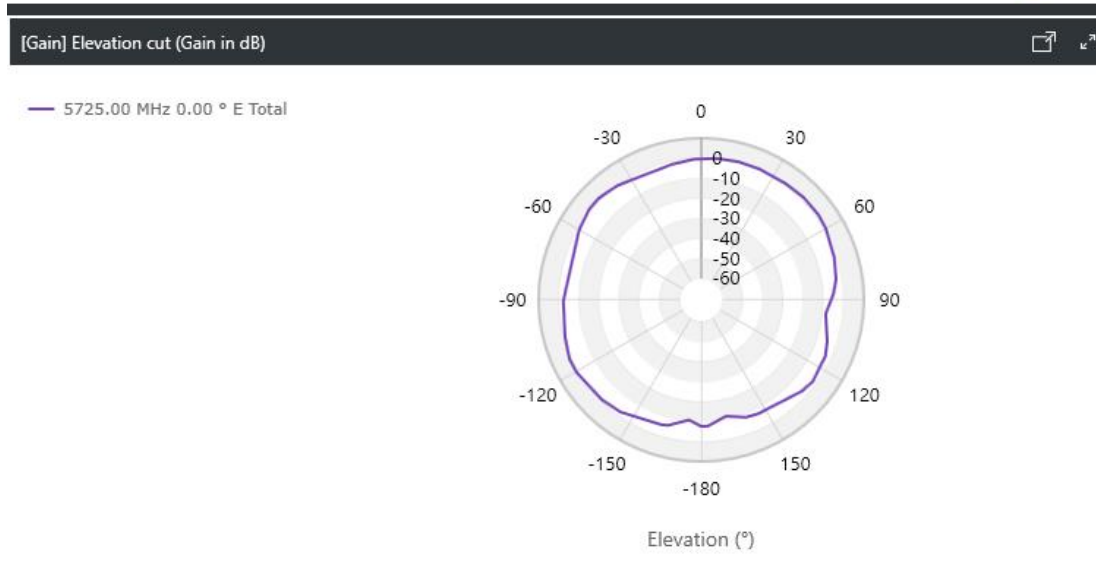
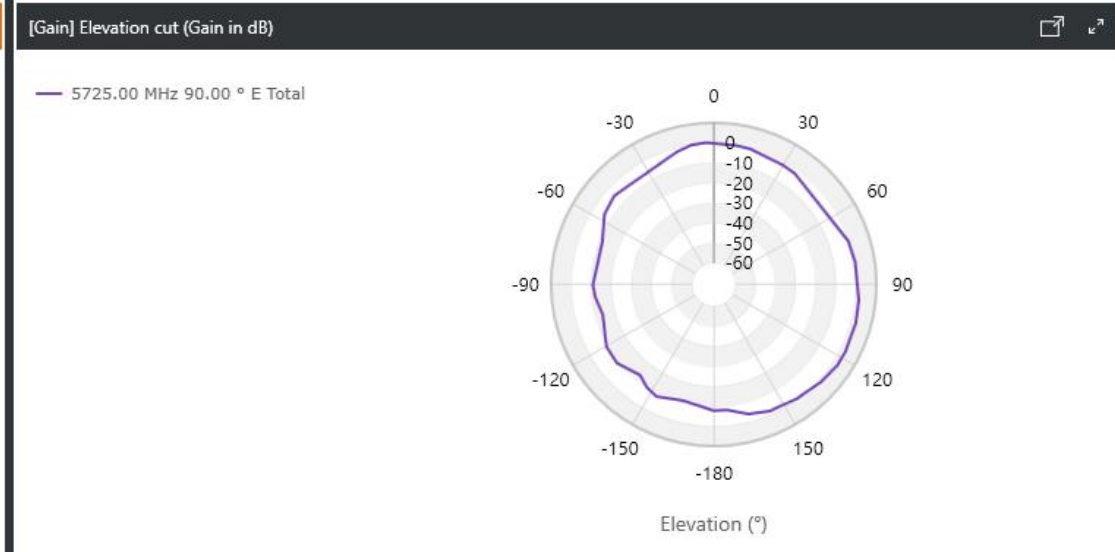
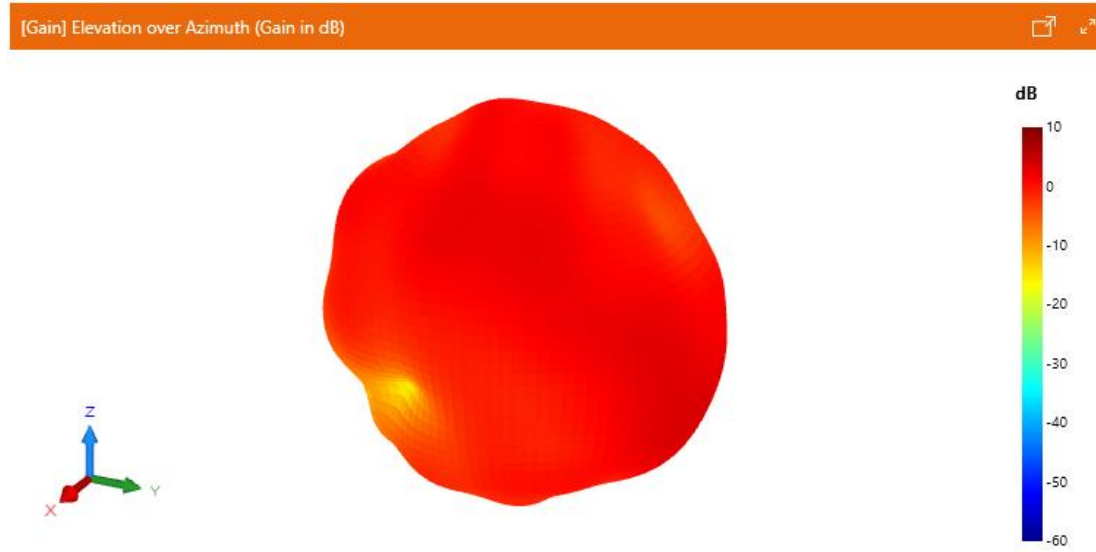

Radiation Patterns_WiFi/BT_5785MHz

3D	ZY-Plane
ZX-Plane	XY-Plane

dB	ZY Plane	ZX Plane	XY Plane
Total(Max.)	2.57	1.87	2.54

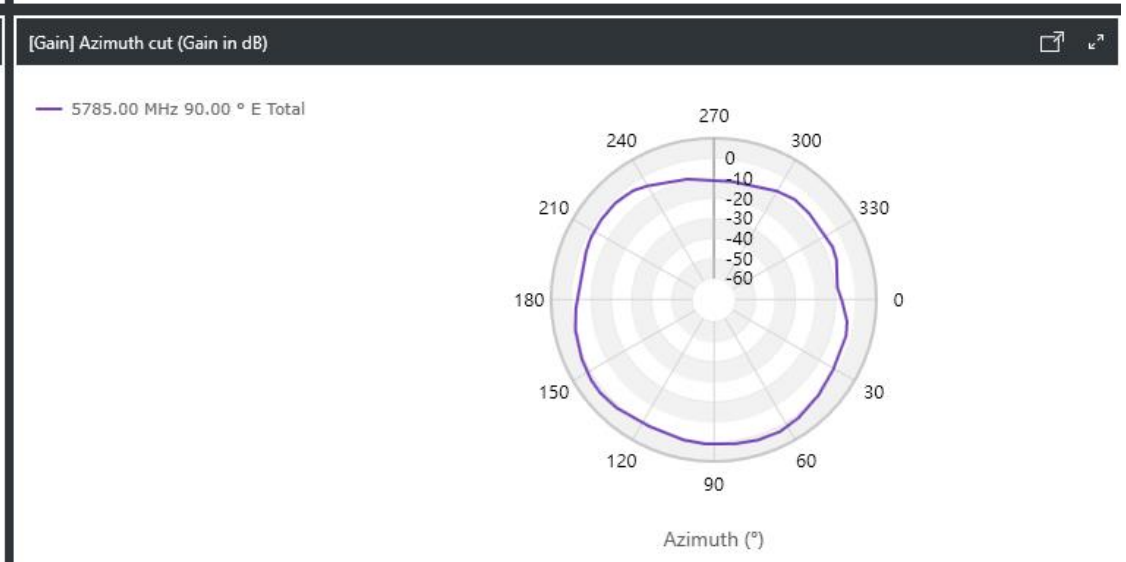
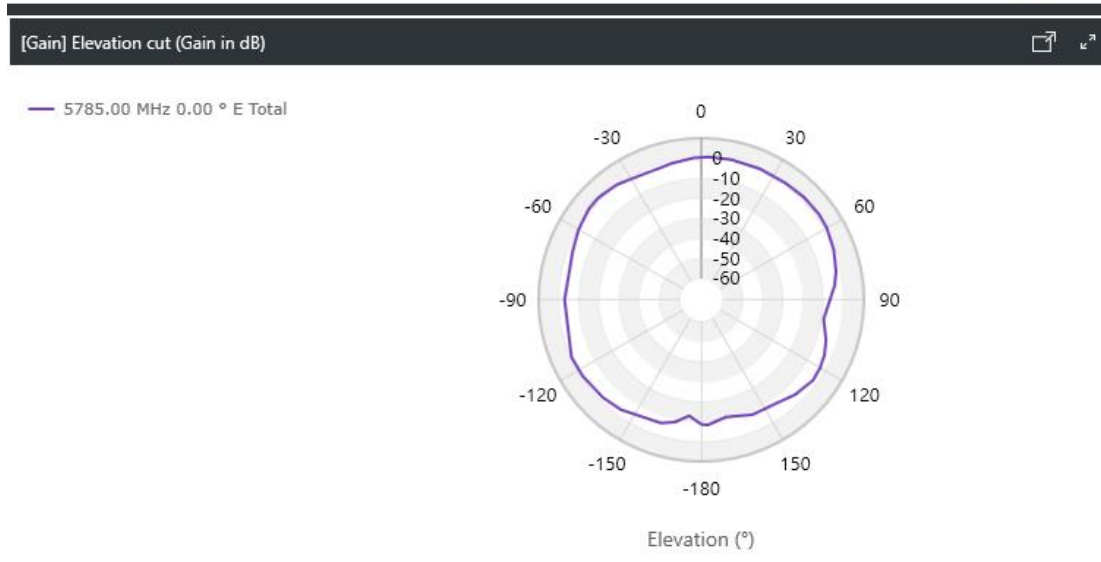
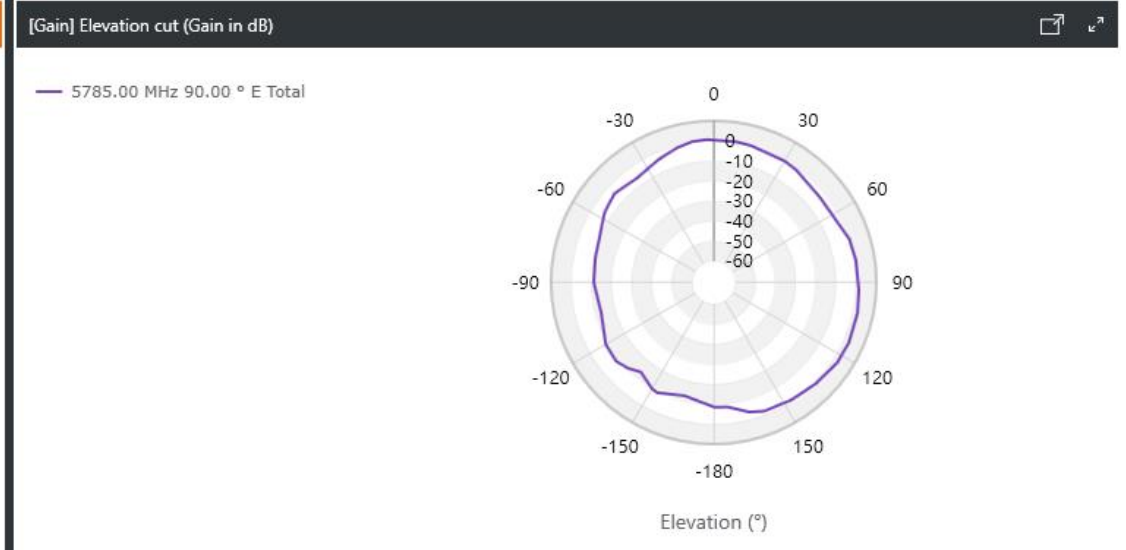
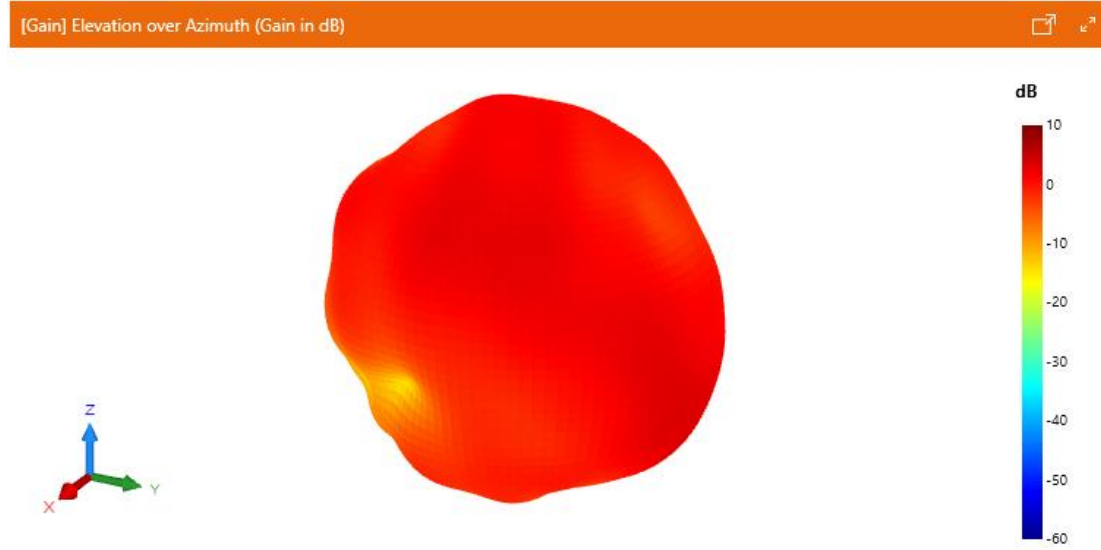

Radiation Patterns_WiFi/BT_5850MHz

3D	ZY-Plane
ZX-Plane	XY-Plane

dB	ZY Plane	ZX Plane	XY Plane
Total(Max.)	2.57	1.79	2.48

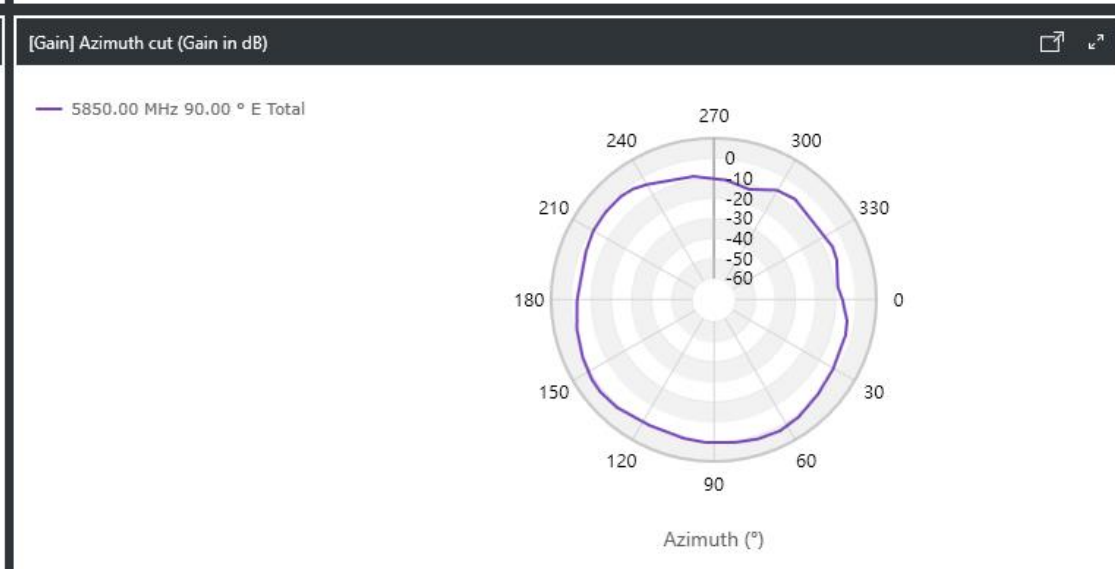
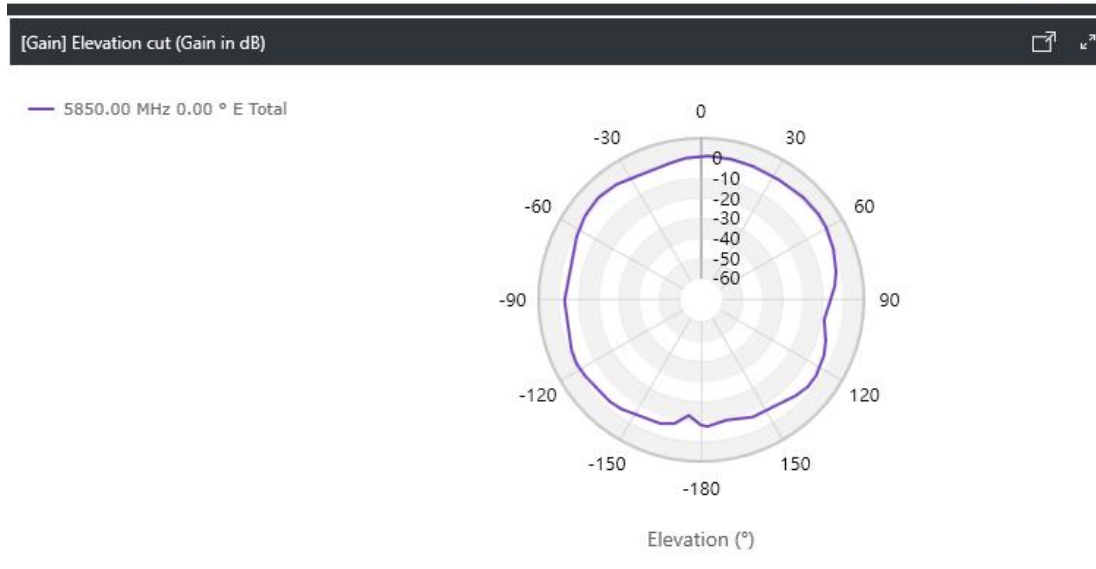
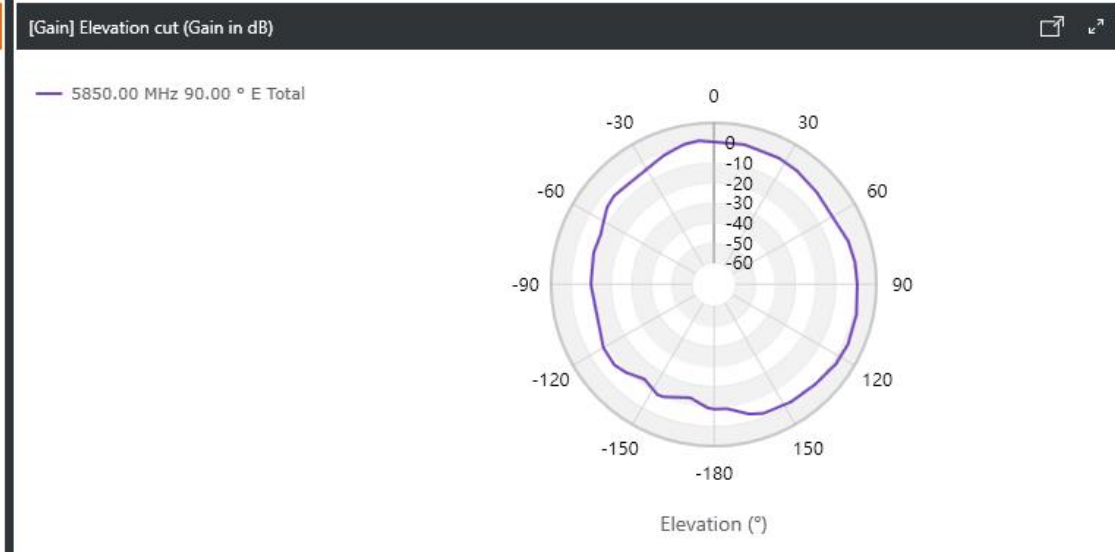
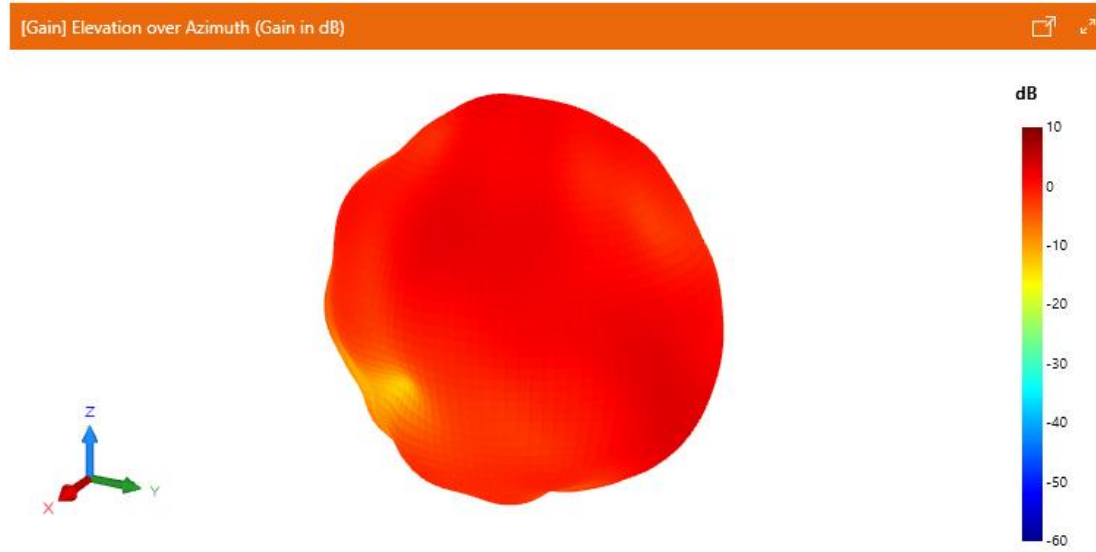



THANK YOU