

# UCW2K Description



# 1 PEN Description

Model No.: PEN 29

Model name : Laser Pen

**Functions: Cordless Pressure Sensitivity Digital Pen with Laser Pointer**

## 1.1. Mechanical Specification

### 1.1.1 Dimensional Outline

- Digital Pen with Laser Pointer (PEN 29)

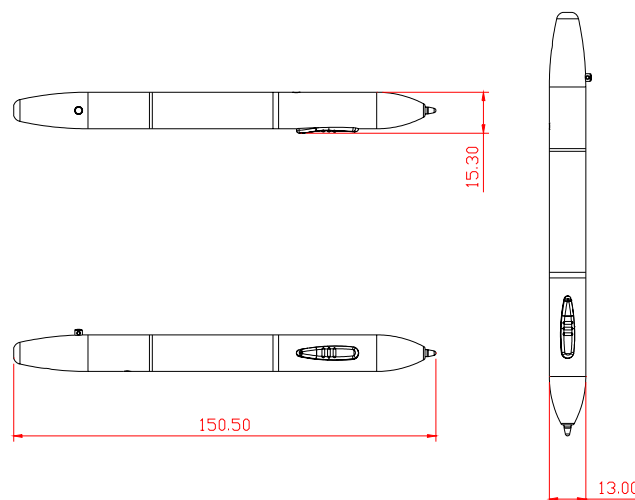

**150 mm (L) ×13.00 mm (Dia.) ×15.30 mm (H)**

## 1.2 Weight

- PEN 29 including one “N” Size battery and three LR41 batteries : 32 g±2g
- PEN 29 Net Weight : 22 g±2g

## 1.3 Color Analysis

- PEN 29 standard color: Customer approved
- Color Model: CIE Lab
- Light source: D65
- View angle: 10°
- Testing Type: Reflectance
- Approved color:  $DE^* < 1.2$

Value

Condition	L*	a*	b*	DL*	Da*	Db*	DE*
Standard Color 8201C	51.403	- 0.069	0.784	- - -	- - -	- - -	- - -
PEN 29 Plastic portion	50.424	- 0.425	0.352	- 0.979	- 0.356	- 0.432	<b>1.127</b>
PEN 29 Aluminum portion	52.234	- 0.124	0.548	- 0.831	- 0.055	- 0.236	<b>0.866</b>

Note:

1. DL\*, Da\*, Db\* represent the differences between standard sample and testing results of PEN 29.
2. DE\* means “Total Differences”

## 1.4 General Specification

- PEN 29 Digital Pen with Laser Pointer

<b>Digital Pen</b>	
Button Style	1 Pen tip button, 2 Barrel button
Button Active Force	Pen tip 30g , Barrel 100 ±50g
Pressure Sensitivity	1024 levels
Battery Life	Cordless Pen: At least 1,000 hrs
Power Source	...1.1. Cordless Pen: One “N” Size battery Laser Pointer: Three LR41 button cell batteries
Work Current	Cordless Pen: 200µA
Stand by Current	Cordless Pen: 200µA
Standby Mode	Cordless Pen: Wait time 5-25 min
Laser Pointer	
<b>Laser Pointer</b>	
Operating voltage (Vop)	3 ~ 5V
Operating current (Iop)	40±15mA
Cw output power (Po)	2.5mW
Wavelength at peak emission ( λ p)	645 ~ 665nm
Collimating lens	Aspherical plastic (ø5)
Housing	Zinc alloy

Spot size at 5m	6±2mm
Divergence	2.0 mrad
Mean time to failure (MTTF) 3mW 25°C	10000 hrs
Operating temp. range	+10°C ~ +30°C
Storage temp. range	-20°C ~ +65°C

## 2. Pen Tablet (UC-Logic TAB-1R)

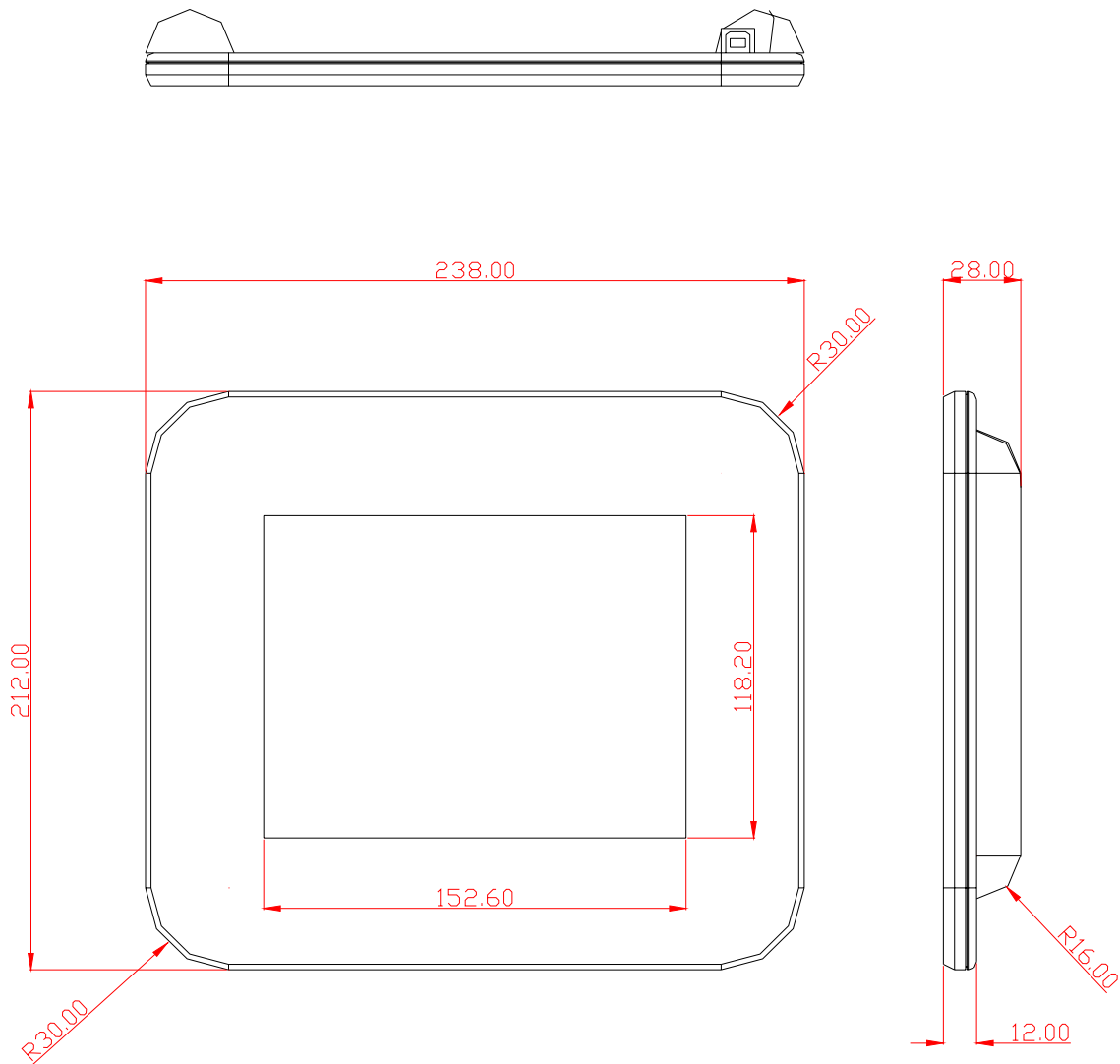

### 2.1 Chalkboard basic spec (UC-Logic TAB-1R)

Tablet Style Number	TAB 1R
Dimensions	238 mm (L) × 212.00 mm (W) × 9.10 mm (H) 註: H 不含腳墊厚度
Active Area	5.50" × 4.00"
Weight	290+- 10g (Tablet Only)
Technology Used	Electromagnetic

Pen Positioning Accuracy	$\pm 0.25$ mm (0.01 inch)
Resolution	1000 LPI (default)
Proximity	5 mm
Report Rate	100 points/sec.
Coordinate Report Mode	Absolute mode
Origin Position	Upper left
Pen Pressure Levels	512
Supply Voltage	DC 5V ( $\pm 5\%$ )
Input Current	40 mA (max)
LED Status	<ol style="list-style-type: none"> <li>1. Initial power on – LED light stays on for about 3 seconds.</li> <li>2. When pen is sensed and any pen switch is pressed – LED light stays on.</li> <li>3. When pen is sensed and no pen switch is pressed – LED light flashes.</li> <li>4. All other cases – LED light is off.</li> </ol>
	5.

### 3. UC2000 (Two way RF Chalkboard RF module)

The Two way RF Chalkboard RF module is a device that lets you connect UC-Logic TAB1R to Two way RF Chalkboard Receiver. The connection over the air makes UC-Logic TAB1R become a *portable* writing pad.

**Top side**



**Bottom side**



### 3.1 Hardware Specification

Microcontroller Chipset	CYPRESS enCoRe USB CY7C63743
RF Chip	CYPRESS WirelessUSB LS 2.4GHz DSSS Radio SoC
Operating Voltage	3.3V ± 5% and 5V+-5%
Antenna	On board printed antenna
Operation Frequency	2.4GHz ISM band
Transmission Range	20 Meters at free sapce
Output Power	Up to 0 dBm
Sensitivity	-90dBm

### 3.2 Physical dimension

- Weight: 4g
- Dimension:

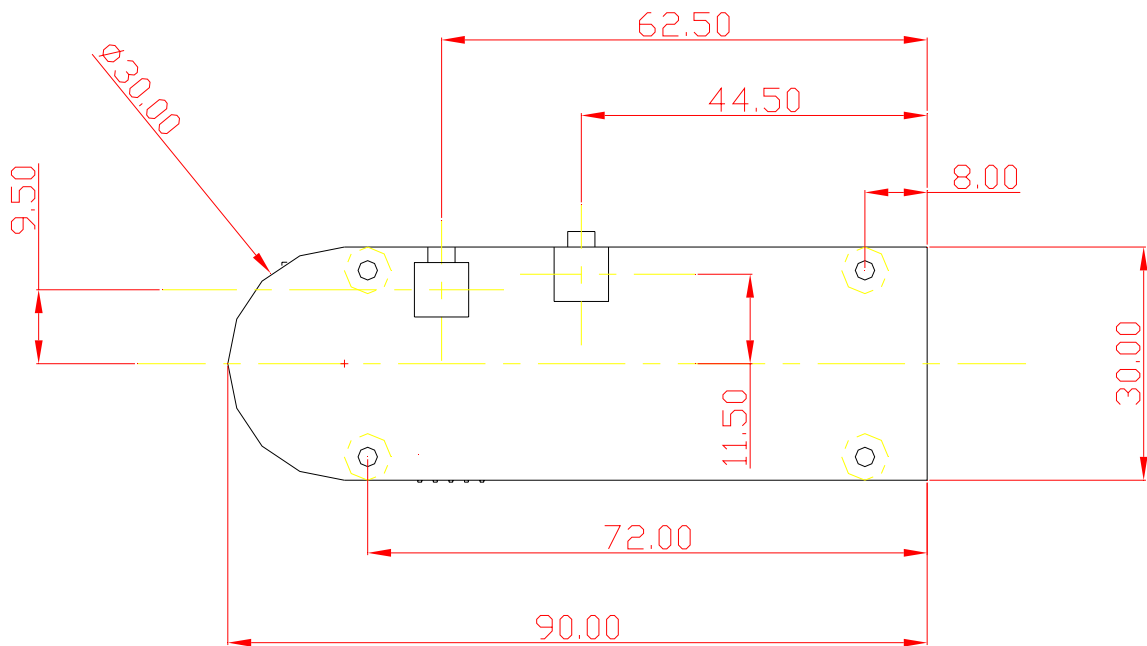



## 4. UB2000 (Chalkboard Charger)

UB2000 is a device that provide UC2000 +5V voltage and provide battery charge function.

**Top side**



**Bottom side**

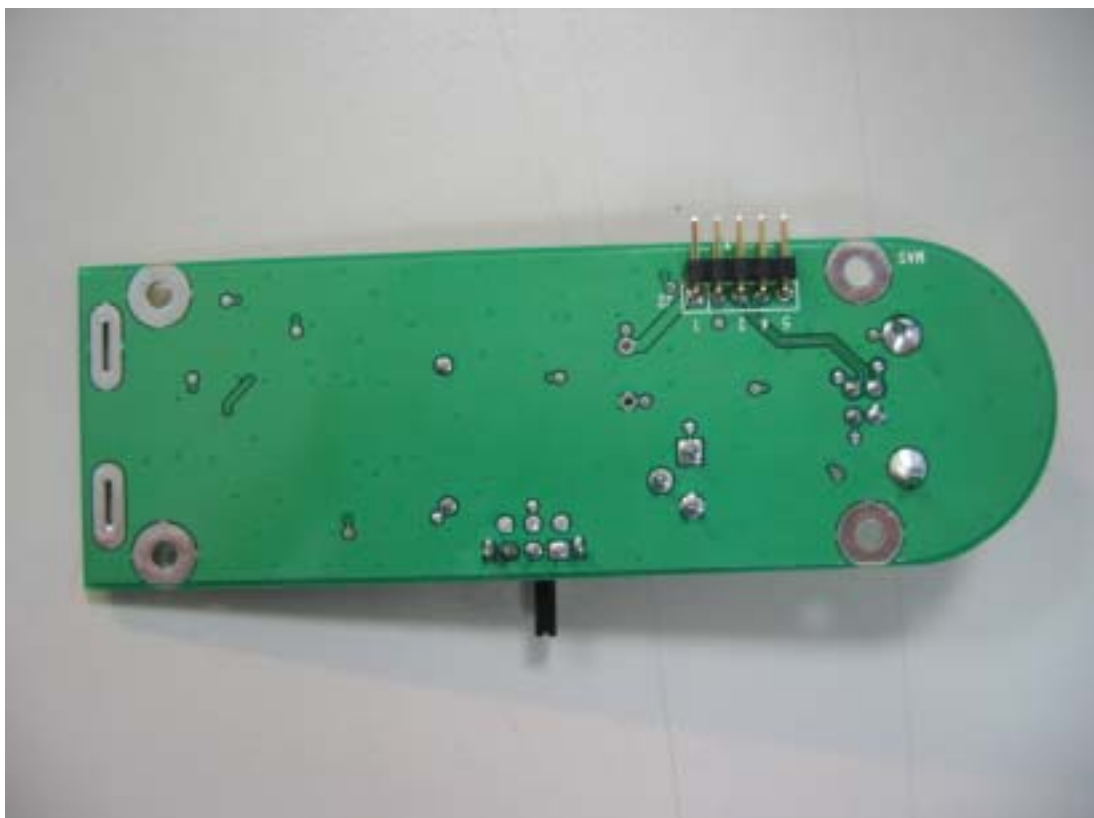

## 4.1 Hardware Specification

VTL = Low Threshold Voltage = approx. 2.74 VDC $\pm$  0.05V

VTH = High Threshold Voltage = approx. 2.94 VDC + - 0.05V

1. Circuit connected to batteries with combined voltage of less than VTL will begin charging batteries at approx 280 mA.
2. As charging batteries reach the combined voltage of VTH, circuit will shut off the charge current into the batteries.
3. Charging can take place if either the DC adapter is plugged in, or USB connector is plugged in and connected to a live host.
4. Both the power of the DC power jack and the USB bus power are protected against surges, EMI and reverse voltage.
5. Plugging in an adapter rated higher than 5VDC will damage the charger (and load, if switch is turned on). The power inputs are not protected against over voltage. (It is recommended that "5V" and the center-pin-positive symbol be imprinted near the DC jack on the enclosure).
6. Do not use with non-rechargeable batteries. NiMH batteries from 1500 to 2400 mAH are preferred type.
7. Battery charge time will vary according to capacity of batteries used and discharge extent.
8. Habitually leaving unit on for long periods and allowing the battery to fully discharge will lead to shorter battery life.
9. Even if switch is in "OFF" position, the batteries will discharge over very long periods of time.
10. Connector J2 provides the following signals:
11. Battery charges at 280mA, and load draws upwards of 200mA. It is recommended that charge adapter be at least 500mA in case battery is charging while load is engaged.

## 5. UW2000 (RF Chalkboard Receiver)

The RF Chalkboard Receiver is a device that lets you connect UC-Logic TAB1R to Two way RF Chalkboard Receiver. The connection over the air makes UC-Logic TAB1R become a *portable* writing pad.

**Top side**



**Bottom side**



## 5.1 Hardware Specification

Microcontroller Chipset	CYPRESS enCoRe USB CY7C63723
RF Chip	CYPRESS WirelessUSB LS 2.4GHz DSSS Radio SoC
Operating Voltage	5V ± 5%
Antenna	On board printed antenna
Operation Frequency	2.4GHz ISM band
Transmission Range	20 Meters at free sapce
Output Power	Up to 0 dBm
Sensitivity	-90dBm

## 5.2 Physical dimension

- Weight: 6g
- Dimension:

