

## System Check\_Body\_2450MHz\_130514

**DUT: D2450V2-SN:736**

Communication System: CW; Frequency: 2450 MHz; Duty Cycle: 1:1

Medium: MSL\_2450\_130514 Medium parameters used:  $f = 2450$  MHz;  $\sigma = 1.922$  S/m;  $\epsilon_r = 53.185$ ;  $\rho =$

$1000$  kg/m<sup>3</sup>

Ambient Temperature : 22.5 °C ; Liquid Temperature : 21.5 °C

DASY5 Configuration:

- Probe: EX3DV4 - SN3697; ConvF(6.57, 6.57, 6.57); Calibrated: 2012/9/28;
- Sensor-Surface: 2mm (Mechanical Surface Detection)
- Electronics: DAE4 Sn1279; Calibrated: 2013/1/28
- Phantom: ELI v4.0; Type: QDOVA001BB; Serial: 1173
- Measurement SW: DASY52, Version 52.8 (4); SEMCAD X Version 14.6.8 (7028)

**Configuration/Pin=250mW/Area Scan (61x61x1):** Interpolated grid: dx=1.200 mm, dy=1.200 mm

Maximum value of SAR (interpolated) = 20.9 W/kg

**Configuration/Pin=250mW/Zoom Scan (7x7x7)/Cube 0:** Measurement grid: dx=5mm, dy=5mm, dz=5mm

Reference Value = 99.594 V/m; Power Drift = -0.01 dB

Peak SAR (extrapolated) = 27.3 W/kg

**SAR(1 g) = 12.4 W/kg; SAR(10 g) = 5.74 W/kg**

Maximum value of SAR (measured) = 19.2 W/kg

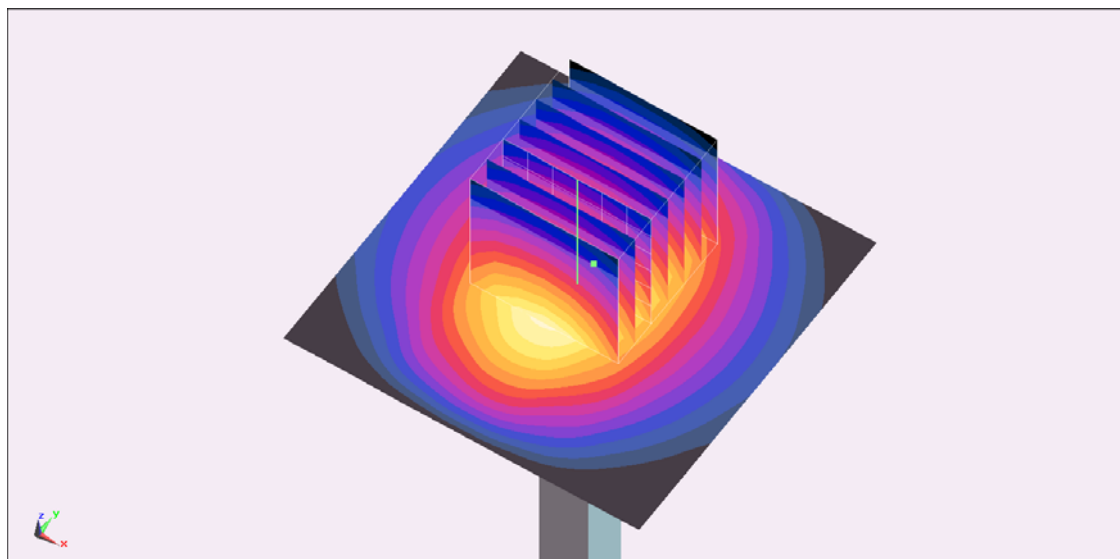
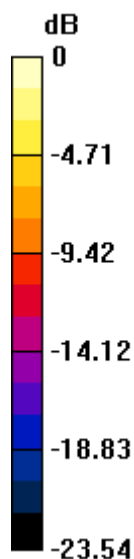

0 dB = 19.2 W/kg = 12.83 dBW/kg

## System Check\_Body\_5200MHz\_130518

### DUT: D5GHzV2-SN:1006

Communication System: CW; Frequency: 5200 MHz; Duty Cycle: 1:1

Medium: MSL\_5G\_130518 Medium parameters used:  $f = 5200$  MHz;  $\sigma = 5.257$  mho/m;  $\epsilon_r = 47.536$ ;  $\rho =$

$1000$  kg/m<sup>3</sup>

Ambient Temperature : 22.4 °C; Liquid Temperature : 21.4 °C

DASY5 Configuration:

- Probe: EX3DV4 - SN3792; ConvF(4.2, 4.2, 4.2); Calibrated: 2012/6/21;
- Sensor-Surface: 1.4mm (Mechanical Surface Detection)
- Electronics: DAE4 Sn1338; Calibrated: 2012/6/12
- Phantom: ELI 4.0\_Front; Type: QDOVA001BB; Serial: 1029
- Measurement SW: DASY52, Version 52.8 (3); SEMCAD X Version 14.6.5 (6469)

**Configuration/Pin=100mW/Area Scan (71x71x1):** Measurement grid: dx=10mm, dy=10mm  
 Maximum value of SAR (interpolated) = 17.0 mW/g

**Configuration/Pin=100mW/Zoom Scan (7x7x7)/Cube 0:** Measurement grid: dx=4mm, dy=4mm, dz=1.4mm

Reference Value = 45.483 V/m; Power Drift = -0.00 dB

Peak SAR (extrapolated) = 25.803 mW/g

**SAR(1 g) = 6.91 mW/g; SAR(10 g) = 1.94 mW/g**

Maximum value of SAR (measured) = 16.4 mW/g

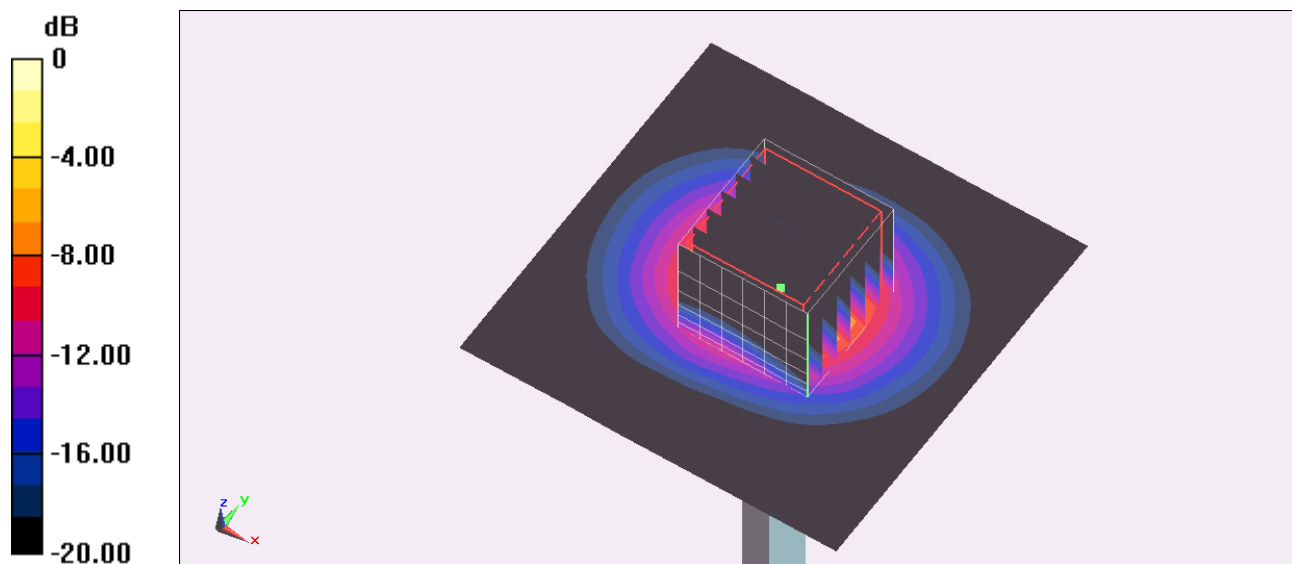

0 dB = 16.4 mW/g = 24.30 dB mW/g

## System Check\_Body\_5800MHz\_130518

### DUT: D5GHzV2-SN:1006

Communication System: CW; Frequency: 5800 MHz; Duty Cycle: 1:1

Medium: MSL\_5G\_130518 Medium parameters used:  $f = 5800$  MHz;  $\sigma = 6.144$  mho/m;  $\epsilon_r = 46.492$ ;  $\rho =$

$1000$  kg/m<sup>3</sup>

Ambient Temperature : 22.4 °C; Liquid Temperature : 21.4 °C

DASY5 Configuration:

- Probe: EX3DV4 - SN3792; ConvF(3.89, 3.89, 3.89); Calibrated: 2012/6/21;
- Sensor-Surface: 1.4mm (Mechanical Surface Detection)
- Electronics: DAE4 Sn1338; Calibrated: 2012/6/12
- Phantom: ELI 4.0\_Front; Type: QDOVA001BB; Serial: 1029
- Measurement SW: DASY52, Version 52.8 (3); SEMCAD X Version 14.6.5 (6469)

**Configuration/Pin=100mW/Area Scan (71x71x1):** Measurement grid: dx=10mm, dy=10mm  
 Maximum value of SAR (interpolated) = 17.6 mW/g

**Configuration/Pin=100mW/Zoom Scan (7x7x7)/Cube 0:** Measurement grid: dx=4mm, dy=4mm, dz=1.4mm

Reference Value = 43.560 V/m; Power Drift = -0.04 dB

Peak SAR (extrapolated) = 29.879 mW/g

**SAR(1 g) = 7.14 mW/g; SAR(10 g) = 1.96 mW/g**

Maximum value of SAR (measured) = 17.9 mW/g

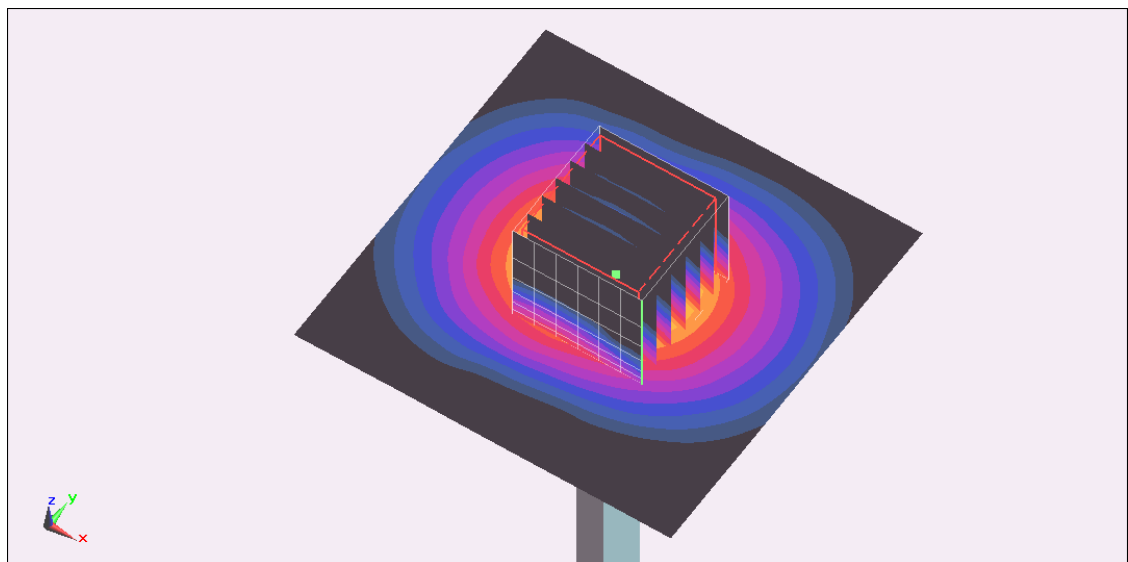
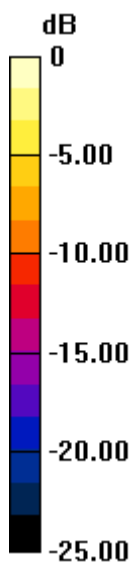

0 dB = 17.9 mW/g = 25.06 dB mW/g

## System Check\_Body\_5800MHz\_130529

### DUT: D5GHzV2-SN:1006

Communication System: CW; Frequency: 5800 MHz; Duty Cycle: 1:1

Medium: MSL\_5G\_130529 Medium parameters used:  $f = 5800 \text{ MHz}$ ;  $\sigma = 6.127 \text{ S/m}$ ;  $\epsilon_r = 46.464$ ;  $\rho =$

$1000 \text{ kg/m}^3$

Ambient Temperature :  $22.2 \text{ }^\circ\text{C}$ ; Liquid Temperature :  $21.2 \text{ }^\circ\text{C}$

#### DASY5 Configuration:

- Probe: EX3DV4 - SN3697; ConvF(4.06, 4.06, 4.06); Calibrated: 2012/9/28;
- Sensor-Surface: 1.4mm (Mechanical Surface Detection)
- Electronics: DAE4 Sn1279; Calibrated: 2013/1/28
- Phantom: ELI v4.0; Type: QDOVA001BB; Serial: 1173
- Measurement SW: DASY52, Version 52.8 (4); SEMCAD X Version 14.6.8 (7028)

**Configuration/Pin=100mW/Area Scan (71x71x1):** Interpolated grid:  $dx=1.000 \text{ mm}$ ,  $dy=1.000 \text{ mm}$

Maximum value of SAR (interpolated) =  $18.5 \text{ W/kg}$

**Configuration/Pin=100mW/Zoom Scan (7x7x7)/Cube 0:** Measurement grid:  $dx=4\text{mm}$ ,  $dy=4\text{mm}$ ,  $dz=1.4\text{mm}$

Reference Value =  $40.568 \text{ V/m}$ ; Power Drift =  $0.04 \text{ dB}$

Peak SAR (extrapolated) =  $38.3 \text{ W/kg}$

**SAR(1 g) =  $6.9 \text{ W/kg}$ ; SAR(10 g) =  $1.86 \text{ W/kg}$**

Maximum value of SAR (measured) =  $17.8 \text{ W/kg}$

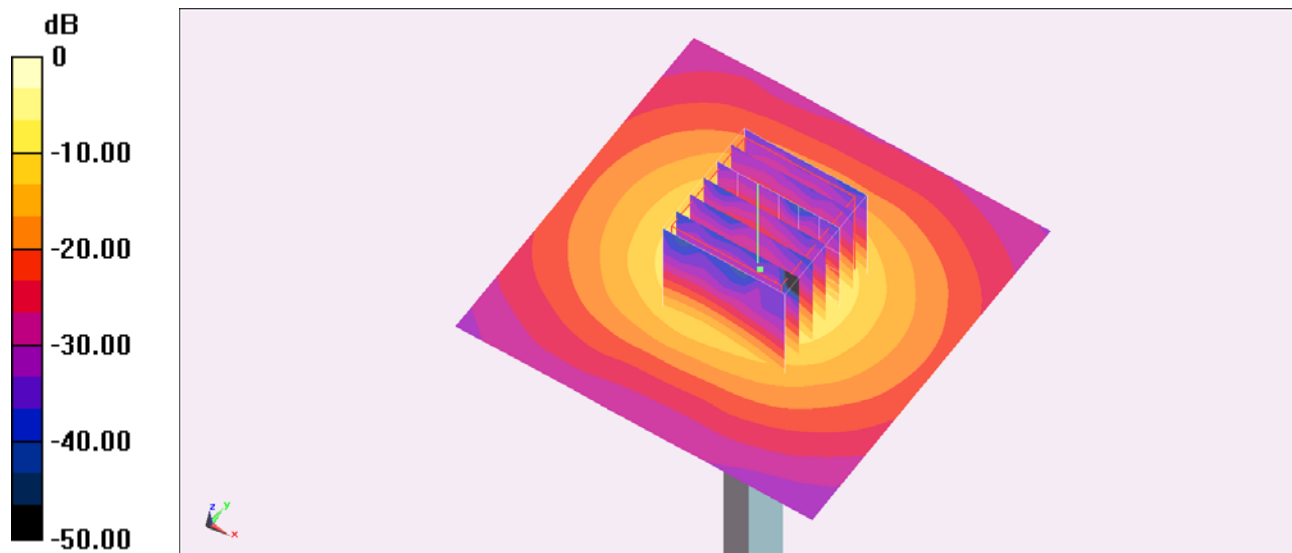

0 dB =  $17.8 \text{ W/kg} = 12.50 \text{ dBW/kg}$