

# FCC TEST REPORT

**REPORT NO.:** RF940527L12

**MODEL NO.:** BSH202  
(refer to page 6 for other models)

**RECEIVED:** May 27, 2005

**TESTED:** May 27 ~ Jun. 03, 2005

**ISSUED:** Jun. 06, 2005

**APPLICANT:** AboCom Systems, Inc.

**ADDRESS:** 1F, No.21, Yanfa 2nd Rd., SBIP, Hsinchu City  
300, Taiwan, R.O.C.

**ISSUED BY:** Advance Data Technology Corporation

**LAB ADDRESS:** No. 47, 14th Ling, Chia Pau Tsuen, Lin Kou  
Hsiang 244, Taipei Hsien, Taiwan, R.O.C.

**TEST LOCATION:** No. 19, Hwa Ya 2<sup>nd</sup> Rd., Wen Hwa Tsuen,  
Kwei Shan Hsiang, Taoyuan Hsien 333,  
Taiwan, R.O.C.

This test report consists of 56 pages in total. It may be duplicated completely for legal use with the approval of the applicant. It should not be reproduced except in full, without the written approval of our laboratory. The client should not use it to claim product endorsement by CNLA, A2LA or any government agency. The test results in the report only apply to the tested sample.



No. 2177-01



0528  
ILAC MRA



## TABLE OF CONTENTS

1	CERTIFICATION .....	4
2	SUMMARY OF TEST RESULTS .....	5
2.1	MEASUREMENT UNCERTAINTY.....	5
3	GENERAL INFORMATION.....	6
3.1	GENERAL DESCRIPTION OF EUT .....	6
3.2	DESCRIPTION OF TEST MODES.....	7
3.2.1	CONFIGURATION OF SYSTEM UNDER TEST .....	8
3.2.2	TEST MODE APPLICABILITY AND TESTED CHANNEL DETAIL .....	9
3.3	GENERAL DESCRIPTION OF APPLIED STANDARDS .....	11
3.4	DESCRIPTION OF SUPPORT UNITS .....	11
4	TEST PROCEDURES AND RESULTS .....	12
4.1	CONDUCTED EMISSION MEASUREMENT .....	12
4.2	NUMBER OF HOPPING FREQUENCY USED .....	12
4.2.1	LIMIT OF HOPPING FREQUENCY USED .....	12
4.2.2	TEST INSTRUMENTS.....	12
4.2.3	TEST PROCEDURES .....	13
4.2.4	DEVIATION FROM TEST STANDARD .....	13
4.2.5	TEST SETUP.....	14
4.2.6	EUT OPERATING CONDITION .....	14
4.2.7	TEST RESULTS .....	14
4.3	DWELL TIME ON EACH CHANNEL .....	16
4.3.1	LIMIT OF DWELL TIME USED.....	16
4.3.2	TEST INSTRUMENTS.....	16
4.3.3	TEST PROCEDURES .....	17
4.3.4	DEVIATION FROM TEST STANDARD .....	17
4.3.5	TEST SETUP.....	17
4.3.6	EUT OPERATING CONDITION .....	17
4.3.7	TEST RESULTS .....	18
4.4	CHANNEL BANDWIDTH.....	22
4.4.1	LIMITS OF CHANNEL BANDWIDTH .....	22
4.4.2	TEST INSTRUMENTS.....	22
4.4.3	TEST PROCEDURE.....	23
4.4.4	DEVIATION FROM TEST STANDARD .....	23
4.4.5	TEST SETUP.....	23
4.4.6	EUT OPERATING CONDITION .....	23
4.4.7	TEST RESULTS .....	24
4.5	HOPPING CHANNEL SEPARATION .....	27
4.5.1	LIMIT OF HOPPING CHANNEL SEPARATION .....	27
4.5.2	TEST INSTRUMENTS.....	27
4.5.3	TEST PROCEDURES .....	28
4.5.4	DEVIATION FROM TEST STANDARD .....	28
4.5.5	TEST SETUP.....	28



4.5.6	EUT OPERATING CONDITION .....	28
4.5.7	TEST RESULTS .....	29
4.6	MAXIMUM PEAK OUTPUT POWER .....	32
4.6.1	LIMITS OF MAXIMUM PEAK OUTPUT POWER MEASUREMENT .....	32
4.6.2	INSTRUMENTS.....	32
4.6.3	TEST PROCEDURES .....	33
4.6.4	DEVIATION FROM TEST STANDARD .....	33
4.6.5	TEST SETUP.....	34
4.6.6	EUT OPERATING CONDITION .....	34
4.6.7	TEST RESULTS .....	35
4.7	RADIATED EMISSION MEASUREMENT .....	38
4.7.1	LIMITS OF RADIATED EMISSION MEASUREMENT .....	38
4.7.2	TEST INSTRUMENTS.....	39
4.7.3	TEST PROCEDURES .....	40
4.7.4	DEVIATION FROM TEST STANDARD .....	40
4.7.5	TEST SETUP.....	41
4.7.6	EUT OPERATING CONDITIONS .....	41
4.7.7	TEST RESULTS .....	42
4.8	BAND EDGES MEASUREMENT .....	48
4.8.1	LIMITS OF BAND EDGES MEASUREMENT.....	48
4.8.2	TEST INSTRUMENTS.....	48
4.8.3	TEST PROCEDURE.....	48
4.8.4	DEVIATION FROM TEST STANDARD .....	48
4.8.5	EUT OPERATING CONDITION .....	49
4.8.6	TEST RESULTS .....	49
4.9	ANTENNA REQUIREMENT .....	52
4.9.1	STANDARD APPLICABLE .....	52
4.9.2	ANTENNA CONNECTED CONSTRUCTION.....	52
5	PHOTOGRAPHS OF THE TEST CONFIGURATION.....	53
6	INFORMATION ON THE TESTING LABORATORIES.....	56



## 1 CERTIFICATION

**PRODUCT :** Bluetooth Stereo Headset  
**BRAND NAME :** AboCom  
**MODEL NO. :** BSH202  
(refer to page 6 for other models)  
**APPLICANT :** AboCom Systems, Inc.  
**TESTED :** May 27 ~ Jun. 03, 2005  
**TEST SAMPLE :** ENGINEERING SAMPLE  
**STANDARDS :** FCC Part 15, Subpart C (Section 15.247)  
ANSI C63.4-2003

The above equipment has been tested by **Advance Data Technology Corporation**, and found compliance with the requirement of the above standards. The test record, data evaluation & Equipment Under Test (EUT) configurations represented herein are true and accurate accounts of the measurements of the sample's EMC characteristics under the conditions specified in this report.

**PREPARED BY :** Windy Chou, **DATE:** Jun. 06, 2005  
(Windy Chou)

**TECHNICAL**  
**ACCEPTANCE :** Gary Chang, **DATE:** Jun. 06, 2005  
Responsible for RF (Gary Chang)

**APPROVED BY :** Cody Chang, **DATE:** Jun. 06, 2005  
(Cody Chang / Deputy Manager)

## 2 SUMMARY OF TEST RESULTS

The EUT has been tested according to the following specifications:

<b>APPLIED STANDARD: FCC Part 15, Subpart C</b>			
<b>Standard Section</b>	<b>Test Type and Limit</b>	<b>Result</b>	<b>Remark</b>
15.207	AC Power Conducted Emission	PASS	Meet the requirement of limit
15.247(a)(1)(iii)	Number of Hopping Frequency Used Spec.: At least 15 channels	PASS	Meet the requirement of limit
15.247(a)(1)(iii)	Dwell Time on Each Channel Spec. : Max. 0.4 second within 31.6 second	PASS	Meet the requirement of limit
15.247(a)(1)	1. Hopping Channel Separation Spec. : Min. 25 kHz or 20 dB bandwidth, whichever is greater 2. Spectrum Bandwidth of a Frequency Hopping Sequence Spread Spectrum System	PASS	Meet the requirement of limit
15.247(b)	Maximum Peak Output Power Spec.: max. 30dBm	PASS	Meet the requirement of limit
15.247(d)	Transmitter Radiated Emissions Spec.: Table 15.209	PASS	Meet the requirement of limit Minimum passing margin is -5.11 dB at 7206.00 MHz
15.247(d)	Band Edge Measurement	PASS	Meet the requirement of limit

### 2.1 MEASUREMENT UNCERTAINTY

Where relevant, the following measurement uncertainty levels have been estimated for tests performed on the EUT as specified in CISPR 16-4:

<b>MEASUREMENT</b>	<b>FREQUENCY</b>	<b>UNCERTAINTY</b>
Conducted emissions	9kHz ~30MHz	2.44 dB
Radiated emissions	30MHz ~ 200MHz	3.63 dB
	200MHz ~1000MHz	3.65 dB
	1GHz ~ 18GHz	2.20 dB
	18GHz ~ 40GHz	1.88 dB

### 3 GENERAL INFORMATION

#### 3.1 GENERAL DESCRIPTION OF EUT

<b>PRODUCT</b>	Bluetooth Stereo Headset
<b>MODEL NO.</b>	BSH202
<b>POWER SUPPLY</b>	3.0Vdc from battery
<b>MODULATION TYPE</b>	GFSK
<b>MODULATION TECHNOLOGY</b>	FHSS
<b>FREQUENCY RANGE</b>	2402 MHz ~ 2480 MHz
<b>NUMBER OF CHANNEL</b>	79
<b>OUTPUT POWER</b>	1.211mW
<b>ANTENNA TYPE</b>	Chip antenna with 1dBi gain
<b>DATA CABLE</b>	NA
<b>I/O PORTS</b>	Audio out

**NOTE:**

1. The following models are provided to this EUT, and identical to each other except for their models due to marketing requirement.

<b>BARD</b>	<b>MODEL NO.</b>	<b>DIFFERENCE</b>
AboCom	BSH202	Same PCB and EUT without Audio output port
AboCom	BSHMC1	Same PCB and EUT with Audio output port

2. Bluetooth technology is used for the EUT.
3. The above EUT information was declared by manufacturer and for more detailed features description, please refer to the manufacturer's specifications or User's Manual.

### 3.2 DESCRIPTION OF TEST MODES

Operated in 2400 ~ 2483.5MHz Band:

79 channels are provided to this EUT.

Channel	Freq. (MHz)	Channel	Freq. (MHz)	Channel	Freq. (MHz)	Channel	Freq. (MHz)
0	2402	20	2422	40	2442	60	2462
1	2403	21	2423	41	2443	61	2463
2	2404	22	2424	42	2444	62	2464
3	2405	23	2425	43	2445	63	2465
4	2406	24	2426	44	2446	64	2466
5	2407	25	2427	45	2447	65	2467
6	2408	26	2428	46	2448	66	2468
7	2409	27	2429	47	2449	67	2469
8	2410	28	2430	48	2450	68	2470
9	2411	29	2431	49	2451	69	2471
10	2412	30	2431	50	2452	70	2472
11	2413	31	2433	51	2453	71	2473
12	2414	32	2434	52	2454	72	2474
13	2415	33	2435	53	2455	73	2475
14	2416	34	2436	54	2456	74	2476
15	2417	35	2437	55	2457	75	2477
16	2418	36	2438	56	2458	76	2478
17	2419	37	2439	57	2459	77	2479
18	2420	38	2440	58	2460	78	2480
19	2421	39	2441	59	2461		



3.2.1 CONFIGURATION OF SYSTEM UNDER TEST

Test Mode 1 & 2

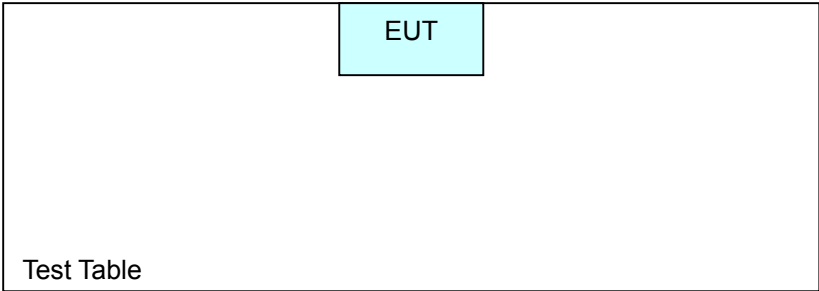

Test Mode 3

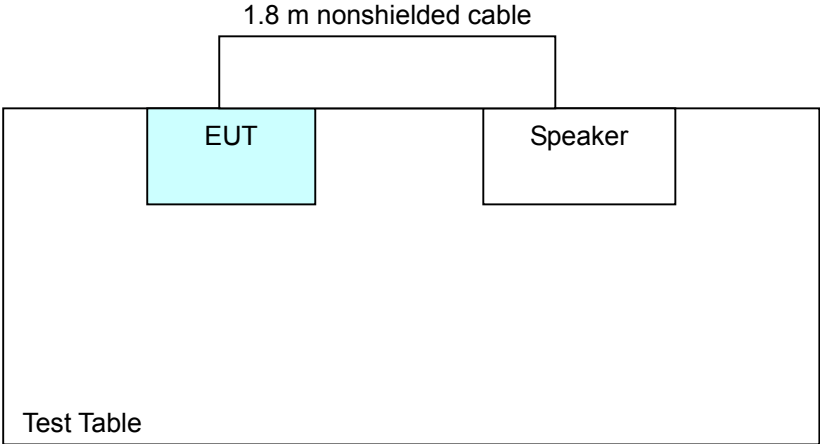





3.2.2 TEST MODE APPLICABILITY AND TESTED CHANNEL DETAIL

EUT configure mode	Applicable to				Description
	PLC	RE<1G	RE≥1G	APCM	
1	-	v	Note 1	Note 2	EUT (Model:BSH202) only (powered by battery)
2	-	v	Note 1	Note 2	EUT (Model:BSHMC1) only (powered by battery)
3	-	v	Note 1	Note 2	EUT (Model:BSHMC1) + Speaker

Where PLC: Power Line Conducted Emission RE<1G RE: Radiated Emission below 1GHz  
 RE≥1G: Radiated Emission above 1GHz APCM: Antenna Port Conducted Measurement

Note 1: No effect on Radiated Emission above 1GHz.  
 Note 2: Conducted RF measurement is independent of Audio Port.

**Radiated Emission Test (Below 1 GHz):**

- Pre-Scan has been conducted to determine the worst-case mode from all possible combinations between available modulations, packet types and XYZ axis.
- Following channel(s) was (were) selected for the final test as listed below.

EUT configure mode	Available Channel	Tested Channel	Modulation Technology	Modulation Type	Packet Type	Position
1	0 to 78	78	FHSS	GFSK	DH5	X
2	0 to 78	78	FHSS	GFSK	DH5	X
3	0 to 78	78	FHSS	GFSK	DH5	X

**Radiated Emission Test (Above 1 GHz):**

- Pre-Scan has been conducted to determine the worst-case mode from all possible combinations between available modulations, packet types and XYZ axis.
- Following channel(s) was (were) selected for the final test as listed below.

EUT configure mode	Available Channel	Tested Channel	Modulation Technology	Modulation Type	Packet Type	Position
3	0 to 78	0, 39, 78	FHSS	GFSK	DH5	X



**Bandedge Measurement:**

- Pre-Scan has been conducted to determine the worst-case mode from all possible combinations between available modulations and packet types.
- Following channel(s) was (were) selected for the final test as listed below.

Available Channel	Tested Channel	Modulation Technology	Modulation Type	Packet Type
0 to 78	0, 78	FHSS	GFSK	DH5

**Antenna Port Conducted Measurement:**

- Pre-Scan has been conducted to determine the worst-case mode from all possible combinations between available modulations and packet types.
- Following channel(s) was (were) selected for the final test as listed below.

Available Channel	Tested Channel	Modulation Technology	Modulation Type	Packet Type
0 to 78	0, 39, 78	FHSS	GFSK	DH5

### 3.3 GENERAL DESCRIPTION OF APPLIED STANDARDS

The EUT is a Bluetooth Stereo Headset. According to the specifications of the manufacturer, it must comply with the requirements of the following standards:

**FCC Part 15, Subpart C. (15.247)**

**ANSI C63.4-2003**

All test items have been performed and recorded as per the above standards.

**NOTE:** The EUT is also considered as a kind of computer peripheral, because the connection to computer is necessary for typical use. It has been verified to comply with the requirements of FCC Part 15, Subpart B, Class B (DoC). The test report has been issued separately.

### 3.4 DESCRIPTION OF SUPPORT UNITS

NO.	PRODUCT	BRAND	MODEL NO.	SERIAL NO.	FCC ID
1	SPEAKER	SANYO	SYSP-802	SP07500040300 838	N/A

NO.	SIGNAL CABLE DESCRIPTION OF THE ABOVE SUPPORT UNITS
1	1.8 m wrapped shielded wire, terminated via drain wire, with 3.5 mm phone plug, w/o core.

**NOTE:** All power cords of the above support units are non shielded (1.8m).

## 4 TEST PROCEDURES AND RESULTS

### 4.1 CONDUCTED EMISSION MEASUREMENT

NA

### 4.2 NUMBER OF HOPPING FREQUENCY USED

#### 4.2.1 LIMIT OF HOPPING FREQUENCY USED

At least 15 channels frequencies, and should be equally spaced.

#### 4.2.2 TEST INSTRUMENTS

Description & Manufacturer	Model No.	Serial No.	Calibrated Until
SPECTRUM ANALYZER	FSEK30	100049	Aug. 12, 2005

**NOTE:**

The calibration interval of the above test instruments is 12 months. And the calibrations are traceable to NML/ROC and NIST/USA.

#### 4.2.3 TEST PROCEDURES

1. Check the calibration of the measuring instrument (SA) using either an internal calibrator or a known signal from an external generator.
2. Turn on the EUT and connect its antenna terminal to measurement via a low loss cable. Then set it to any one measured frequency within its operating range and make sure the instrument is operated in its linear range.
3. Set the SA on MaxHold Mode, and then keep the EUT in hopping mode. Record all the signals from each channel until each one has been recorded.
4. Set the SA on View mode and then plot the result on SA screen.
5. Repeat above procedures until all frequencies measured were complete.

#### 4.2.4 DEVIATION FROM TEST STANDARD

No deviation

#### 4.2.5 TEST SETUP

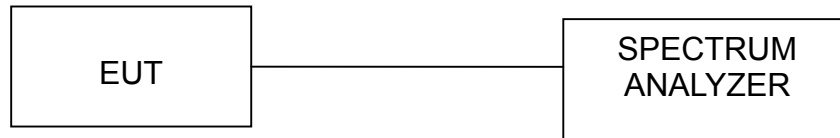

#### 4.2.6 EUT OPERATING CONDITION

The software provided by client enabled the EUT to transmit and receive data at lowest, middle and highest channel frequencies individually.

#### 4.2.7 TEST RESULTS

There are 79 hopping frequencies in the hopping mode. Please refer to next two pages for the test result. On the plots, it shows that the hopping frequencies are equally spaced.

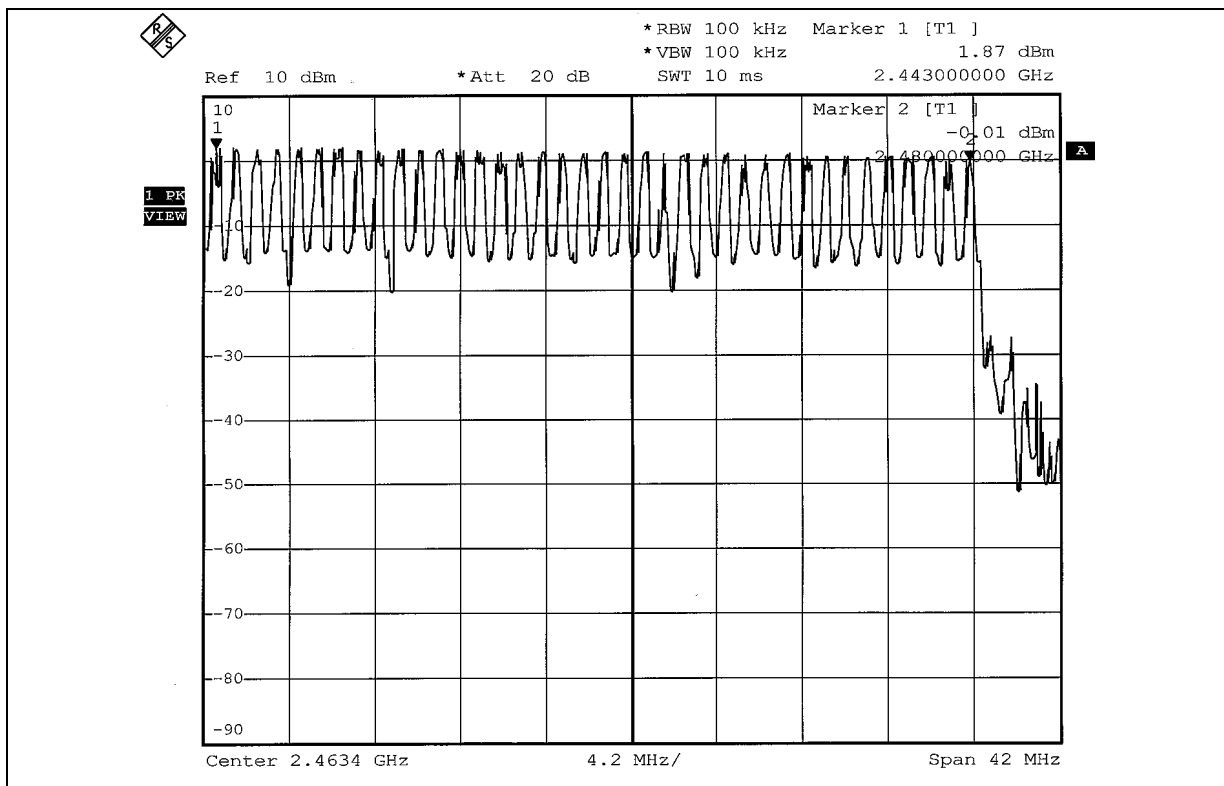
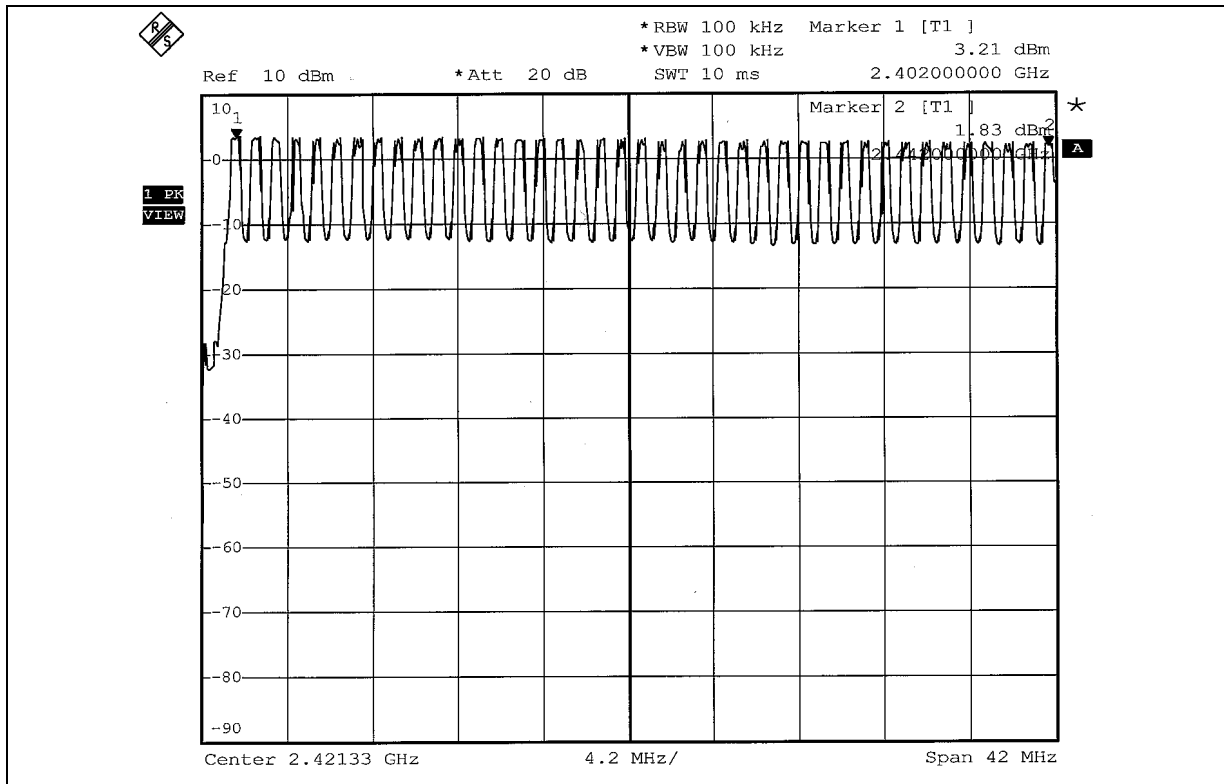

### 4.3 DWELL TIME ON EACH CHANNEL

#### 4.3.1 LIMIT OF DWELL TIME USED

The average time of occupancy on any channel shall not be greater than 0.4 seconds within a period of 0.4 seconds multiplied by the number of hopping channels employed.

#### 4.3.2 TEST INSTRUMENTS

Description & Manufacturer	Model No.	Serial No.	Calibrated Until
SPECTRUM ANALYZER	FSEK30	100049	Aug. 12, 2005

**NOTE:**

The calibration interval of the above test instruments is 12 months. And the calibrations are traceable to NML/ROC and NIST/USA.



#### 4.3.3 TEST PROCEDURES

1. Check the calibration of the measuring instrument (SA) using either an internal calibrator or a known signal from an external generator.
2. Turn on the EUT and connect its antenna terminal to measurement via a low loss cable. Then set it to any one measured frequency within its operating range and make sure the instrument is operated in its linear range.
3. Adjust the center frequency of SA on any frequency be measured and set SA to zero span mode. And then, set RBW and VBW of spectrum analyzer to proper value.
4. Measure the time duration of one transmission on the measured frequency. And then plot the result with time difference of this time duration.
5. Repeat above procedures until all frequencies measured were complete.

#### 4.3.4 DEVIATION FROM TEST STANDARD

No deviation

#### 4.3.5 TEST SETUP



#### 4.3.6 EUT OPERATING CONDITION

The software provided by client enabled the EUT to transmit and receive data at lowest, middle and highest channel frequencies individually.

## 4.3.7 TEST RESULTS

Mode	Number of transmission in a 31.6 (79Hopping*0.4)	Length of transmission time (msec)	Result (msec)	Limit (msec)
DH1	50 (times / 5 sec) *6.32=316.00 times	0.450	142.20	400
DH3	24 (times / 5 sec) *6.32=151.68times	1.716	260.28	400
DH5	16 (times / 5 sec) *6.32=101.12 times	2.990	302.34	400

Test plots of the transmitting time slot are shown on next 3 pages.



DH1

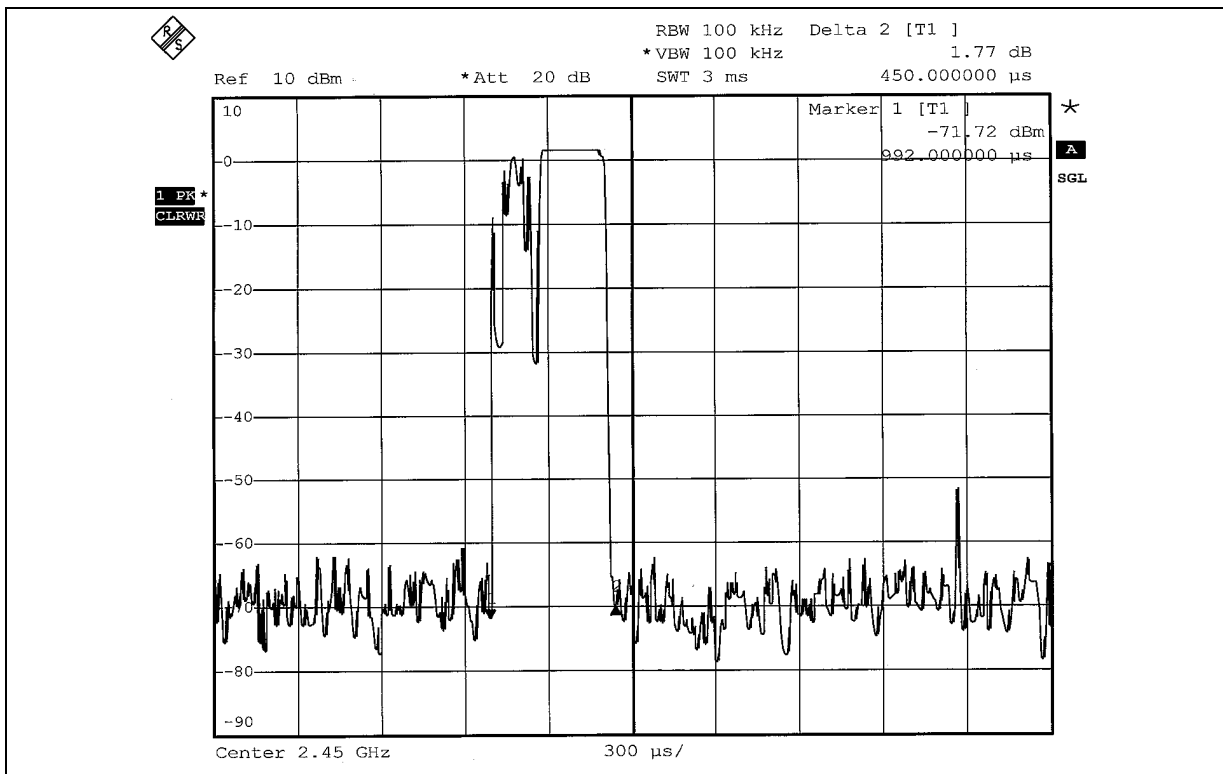
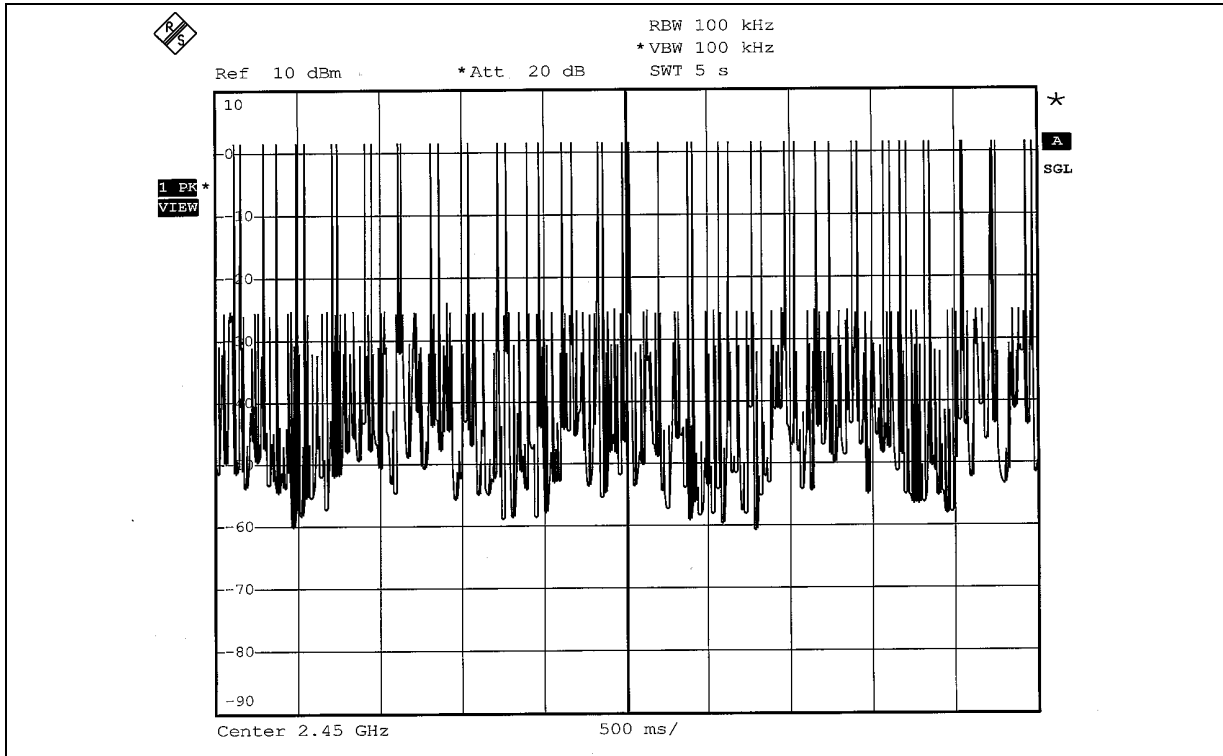



DH3

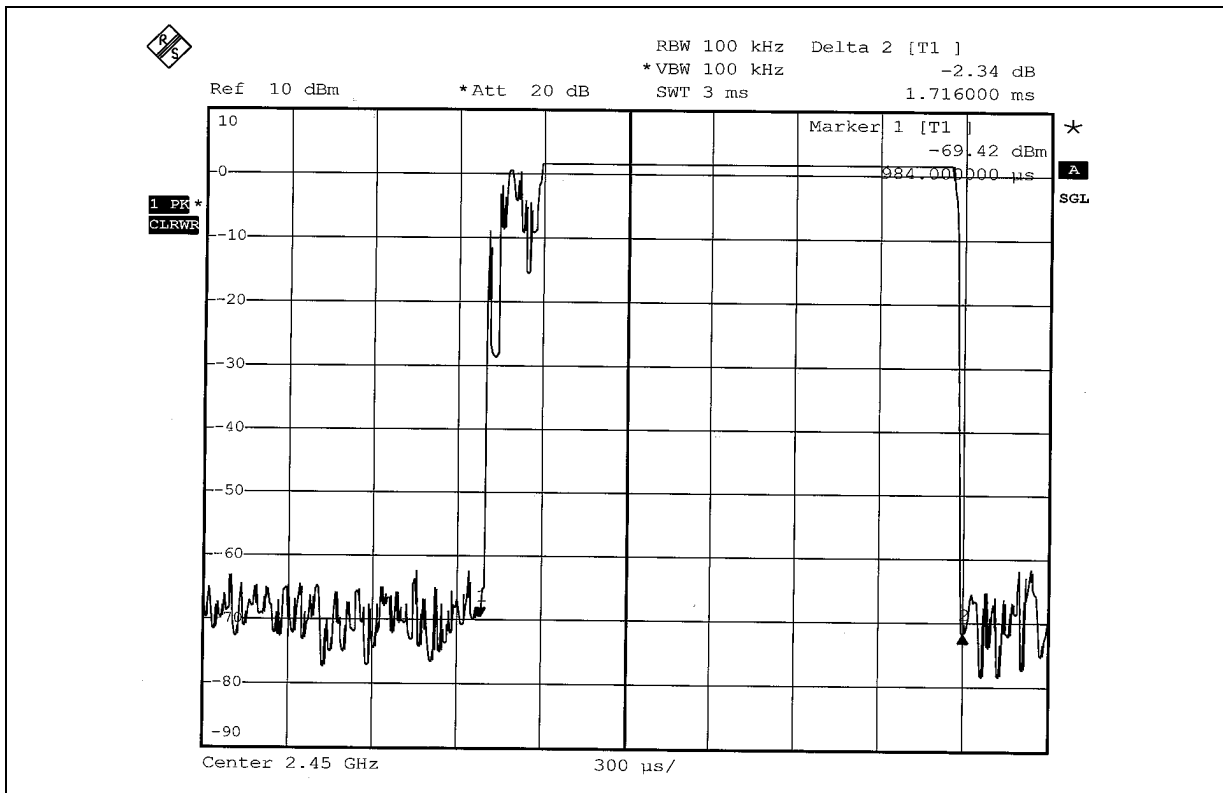
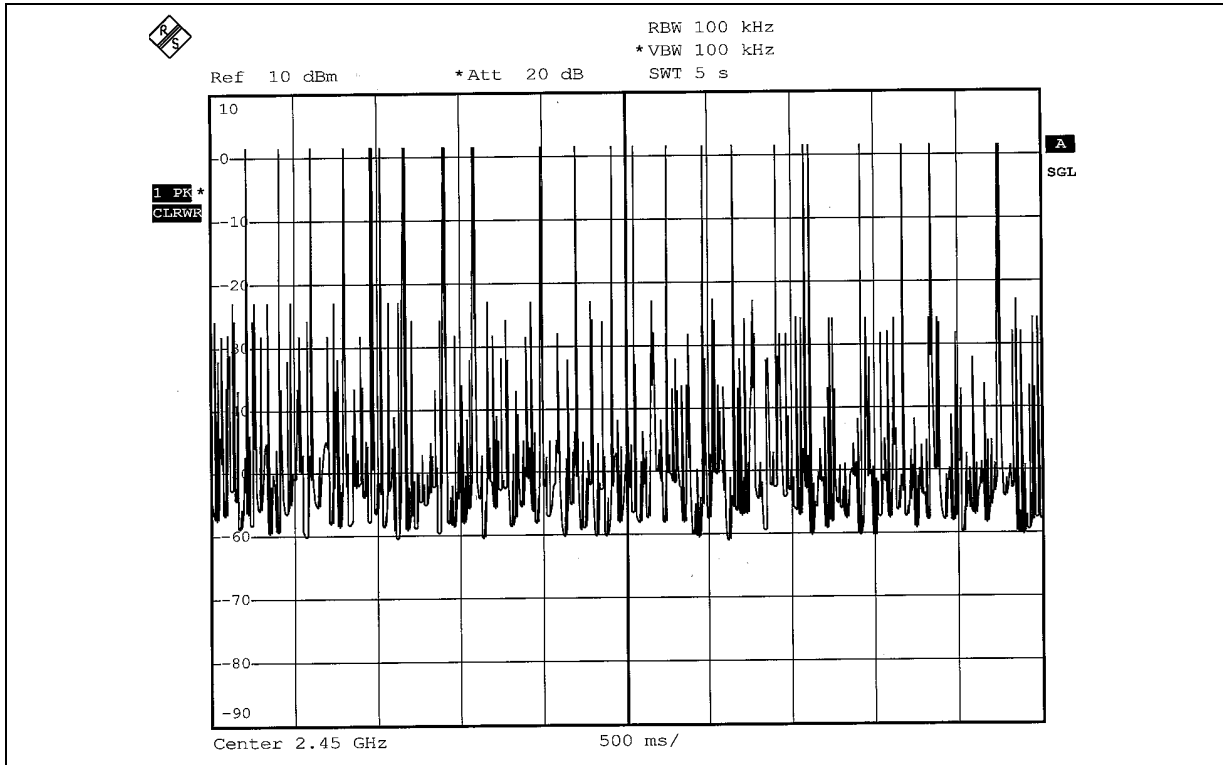



DH5

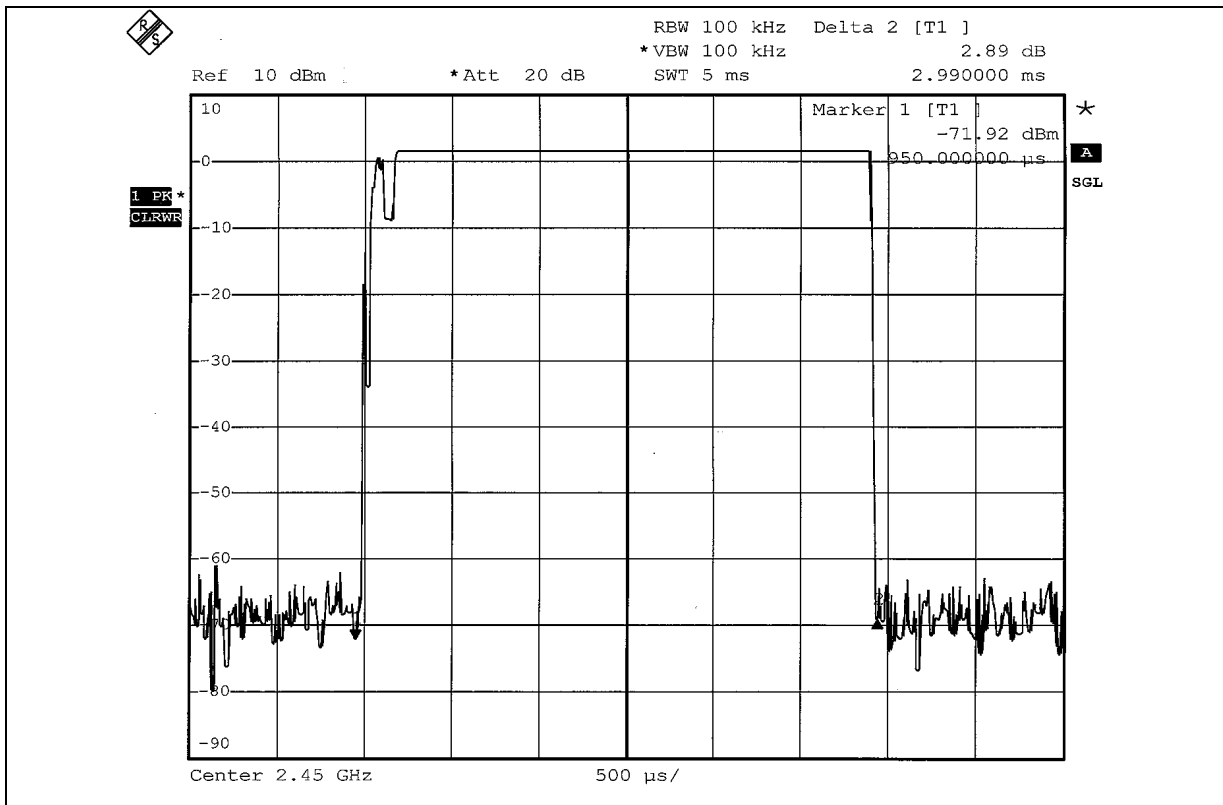
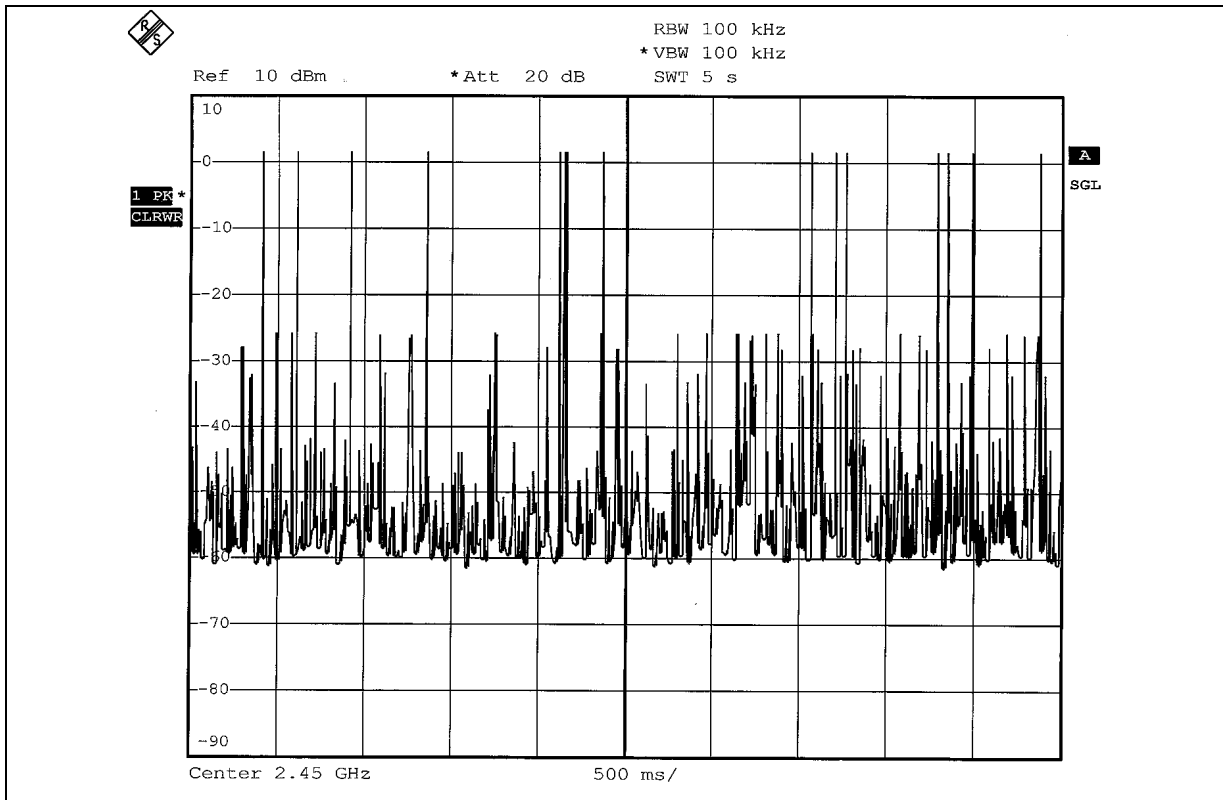

#### 4.4 CHANNEL BANDWIDTH

##### 4.4.1 LIMITS OF CHANNEL BANDWIDTH

For frequency hopping system operating in the 2400-2483.5MHz, If the 20dB bandwidth of hopping channel is greater than 25kHz, the 20dB bandwidth of hopping channel shall be a minimum limit for the hopping channel separation.

##### 4.4.2 TEST INSTRUMENTS

Description & Manufacturer	Model No.	Serial No.	Calibrated Until
SPECTRUM ANALYZER	FSEK30	100049	Aug. 12, 2005

**NOTE:**

The calibration interval of the above test instruments is 12 months. And the calibrations are traceable to NML/ROC and NIST/USA.

#### 4.4.3 TEST PROCEDURE

1. Check the calibration of the measuring instrument using either an internal calibrator or a known signal from an external generator.
2. Turn on the EUT and connect it to measurement instrument. Then set it to any one convenient frequency within its operating range. Set a reference level on the measuring instrument equal to the highest peak value.
3. Measure the frequency difference of two frequencies that were attenuated 20dB from the reference level. Record the frequency difference as the emission bandwidth.
4. Repeat above procedures until all frequencies measured were complete.

#### 4.4.4 DEVIATION FROM TEST STANDARD

No deviation

#### 4.4.5 TEST SETUP

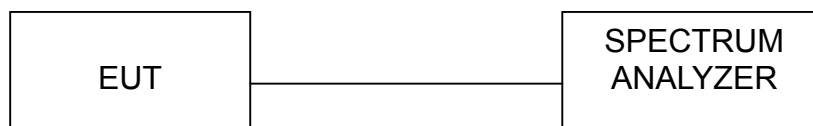

#### 4.4.6 EUT OPERATING CONDITION

The software provided by client enabled the EUT to transmit and receive data at lowest, middle and highest channel frequencies individually.

## 4.4.7 TEST RESULTS

<b>EUT</b>	Bluetooth Stereo Headset	<b>MODEL</b>	BSH202
<b>MODULATION TYPE</b>	GFSK	<b>ENVIRONMENTAL CONDITIONS</b>	23 deg. C, 54% RH, 991 hPa
<b>INPUT POWER (SYSTEM)</b>	120Vac, 60 Hz	<b>TESTED BY</b>	Long Chen

<b>CHANNEL</b>	<b>CHANNEL FREQUENCY (MHz)</b>	<b>20dB BANDWIDTH (kHz)</b>	<b>More Than 25kHz</b>
0	2402	978	Yes
39	2441	975	Yes
78	2480	981	Yes





Channel 0

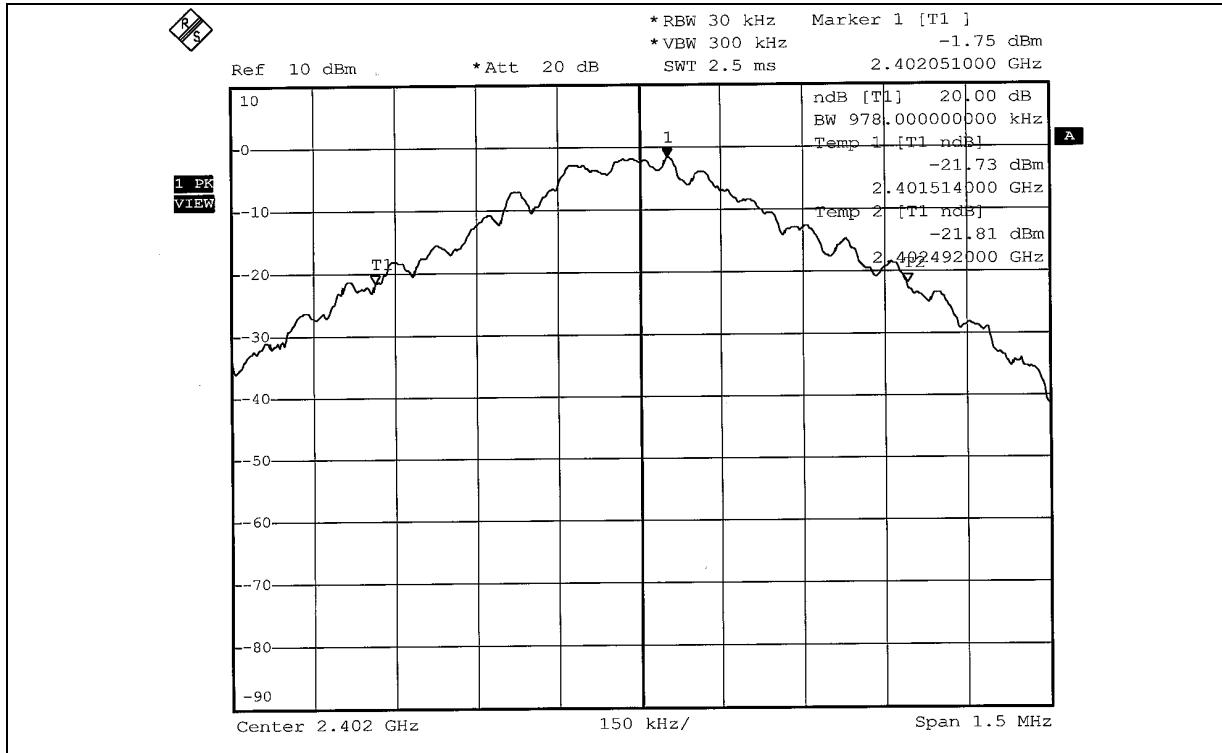

Channel 39

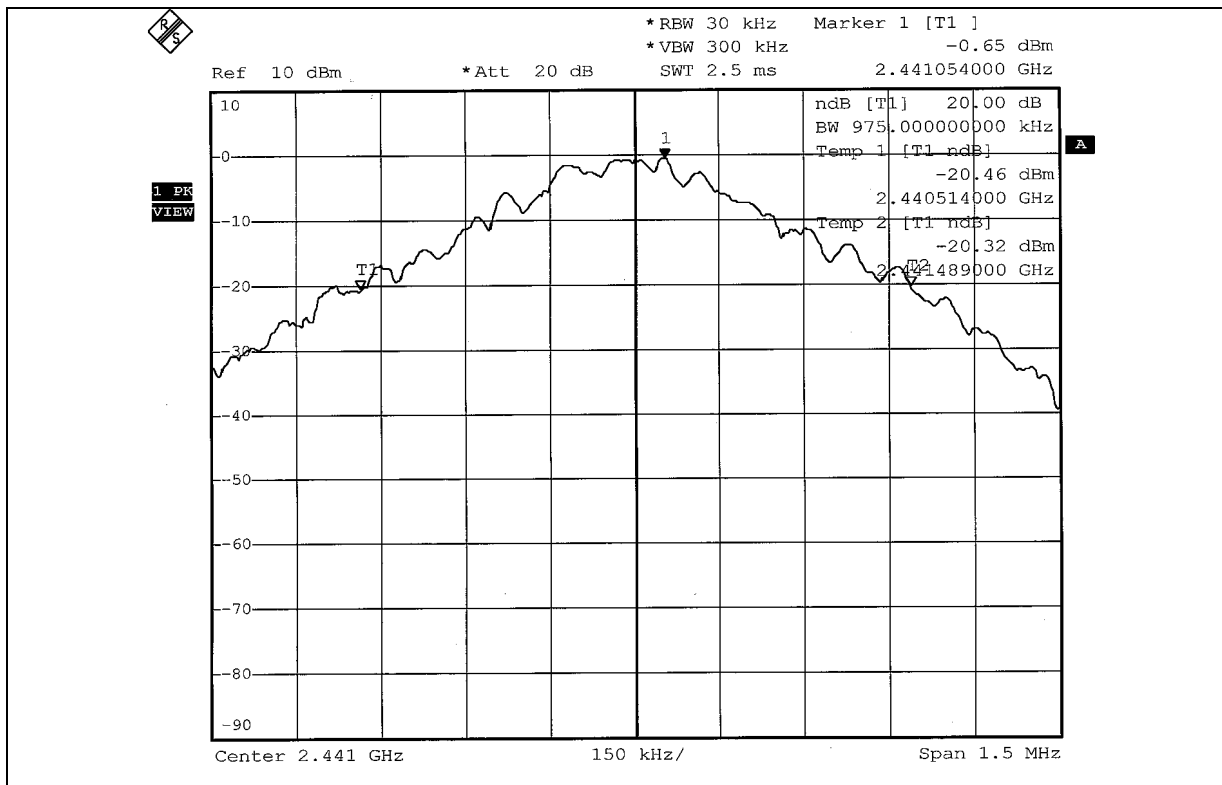



Channel 78

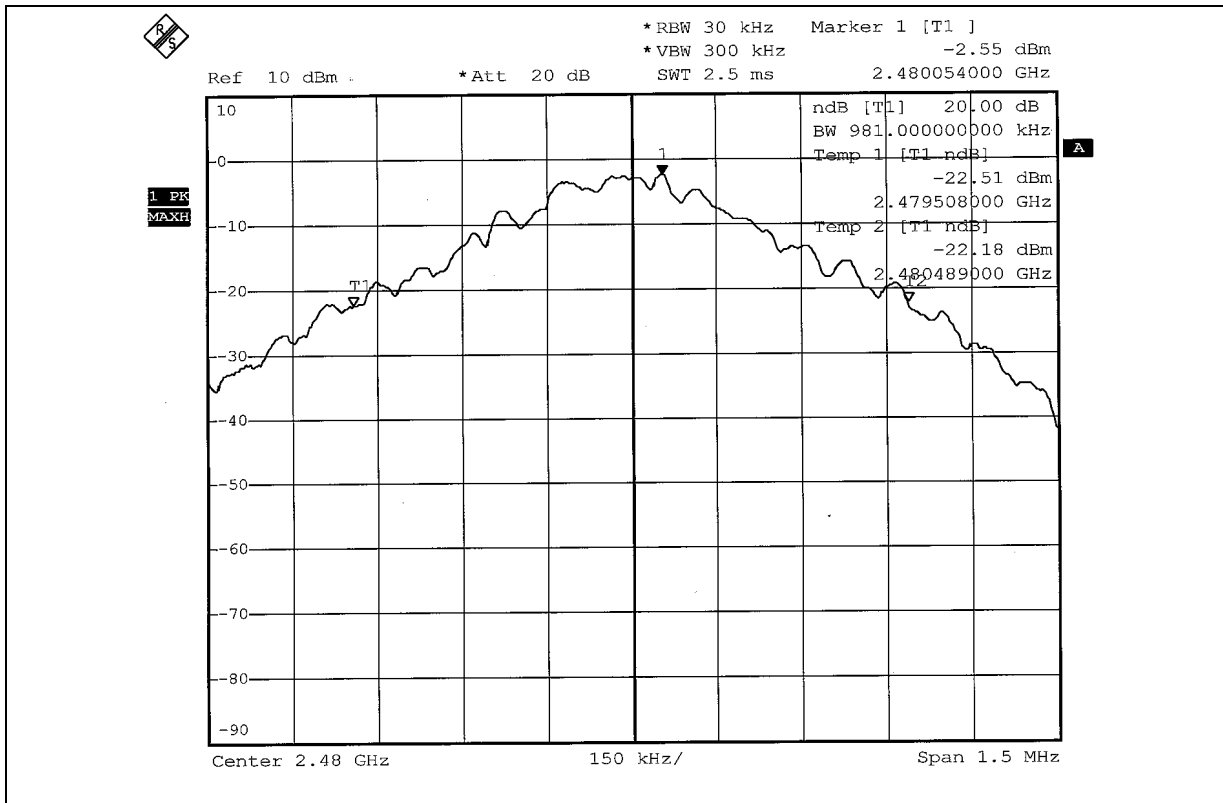

## 4.5 HOPPING CHANNEL SEPARATION

### 4.5.1 LIMIT OF HOPPING CHANNEL SEPARATION

At least 25kHz or 20dB bandwidth (whichever is greater).

### 4.5.2 TEST INSTRUMENTS

Description & Manufacturer	Model No.	Serial No.	Calibrated Until
SPECTRUM ANALYZER	FSEK30	100049	Aug. 12, 2005

**NOTE:**

The calibration interval of the above test instruments is 12 months. And the calibrations are traceable to NML/ROC and NIST/USA.

#### 4.5.3 TEST PROCEDURES

1. Check the calibration of the measuring instrument using either an internal calibrator or a known signal from an external generator.
2. Turn on the EUT and connect it to measurement instrument. Then set it to any one convenient frequency within its operating range.
3. By using the MaxHold function record the separation of two adjacent channels.
4. Measure the frequency difference of these two adjacent channels by SA MARK function. And then plot the result on SA screen.
5. Repeat above procedures until all frequencies measured were complete.

#### 4.5.4 DEVIATION FROM TEST STANDARD

No deviation

#### 4.5.5 TEST SETUP

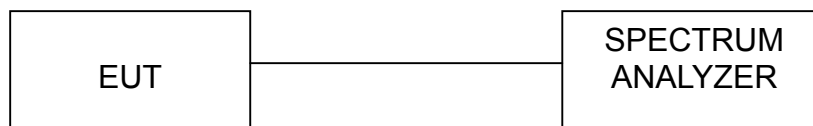

#### 4.5.6 EUT OPERATING CONDITION

The software provided by client enabled the EUT to transmit and receive data at lowest, middle and highest channel frequencies individually.

## 4.5.7 TEST RESULTS

<b>EUT</b>	Bluetooth Stereo Headset	<b>MODEL</b>	BSH202
<b>MODULATION TYPE</b>	GFSK	<b>ENVIRONMENTAL CONDITIONS</b>	23 deg. C, 54% RH, 991 hPa
<b>INPUT POWER (SYSTEM)</b>	120Vac, 60 Hz	<b>TESTED BY</b>	Long Chen

Channel	Frequency (MHz)	Adjacent Channel Separation	Minimum Limit (kHz)	Pass / Fail
0	2402	1.015 MHz	978	PASS
39	2441	1.005 MHz	975	PASS
78	2480	1.000 MHz	981	PASS

The minimum limit is 20dB bandwidth. Test results please refer to next 2 pages.



### Channel 0

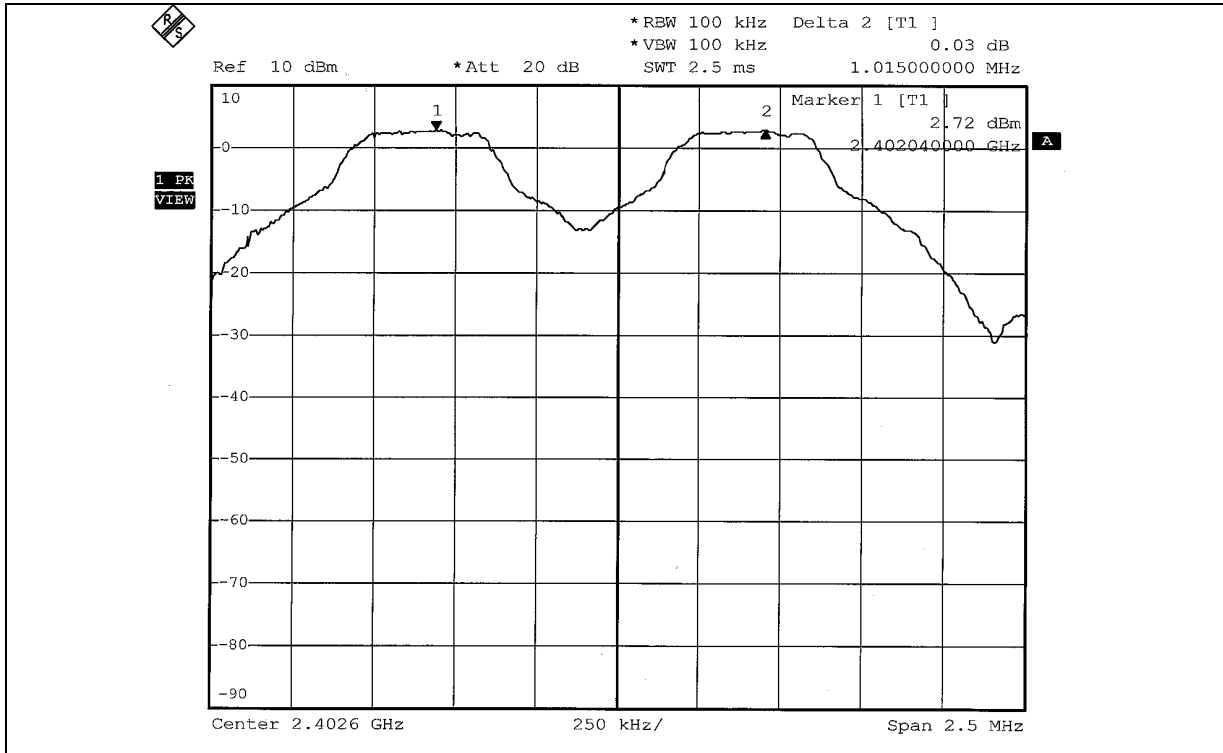

### Channel 39

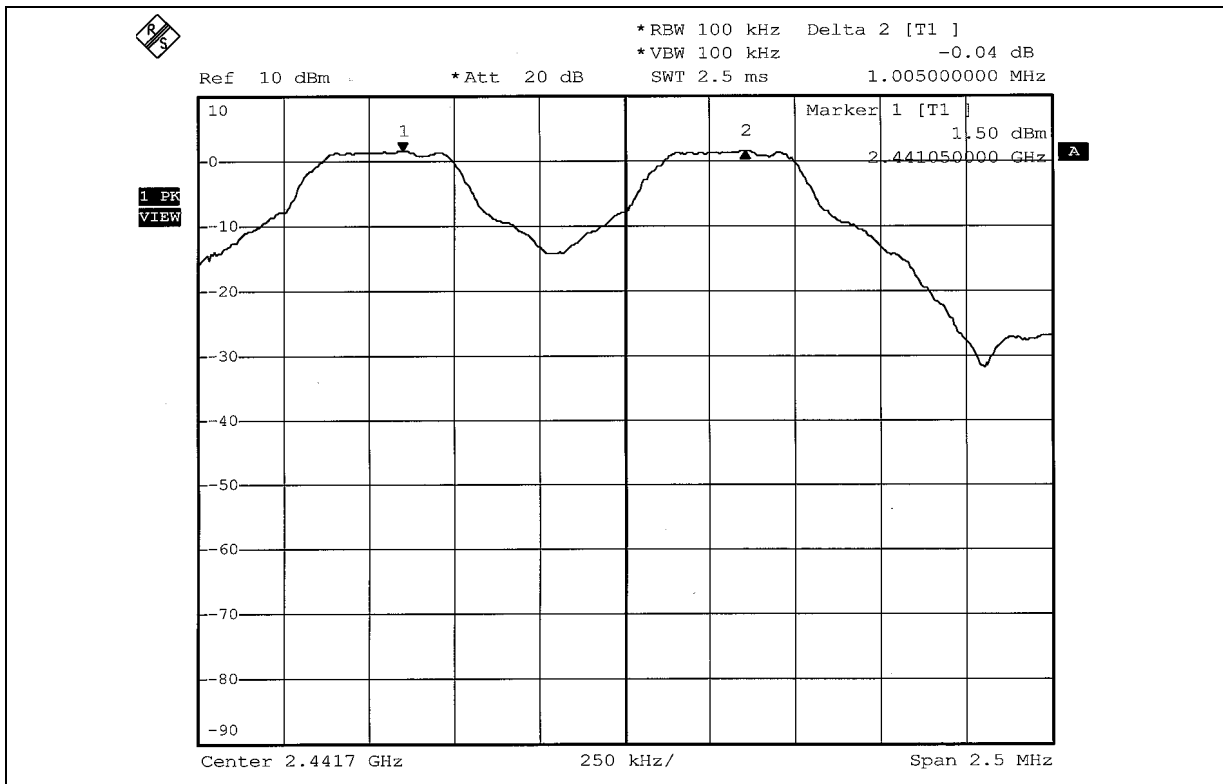



Channel 78

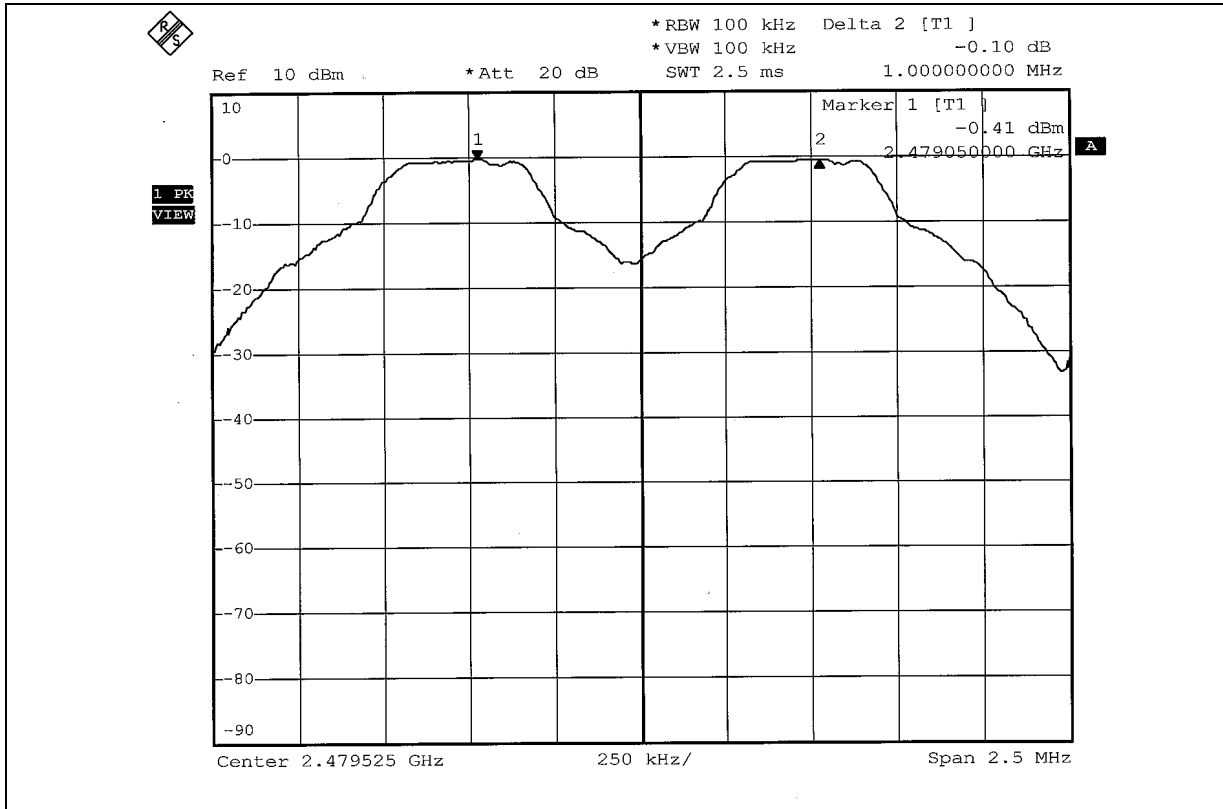

#### 4.6 MAXIMUM PEAK OUTPUT POWER

##### 4.6.1 LIMITS OF MAXIMUM PEAK OUTPUT POWER MEASUREMENT

The Maximum Peak Output Power Measurement is 30dBm.

##### 4.6.2 INSTRUMENTS

Description & Manufacturer	Model No.	Serial No.	Calibrated Until
SPECTRUM ANALYEER	FSEK30	100049	Aug. 12, 2005

**NOTE:** The calibration interval of the above test instruments is 12 months and the calibrations are traceable to NML/ROC and NIST/USA.



#### 4.6.3 TEST PROCEDURES

1. Check the calibration of the measuring instrument using either an internal calibrator or a known signal from an external generator.
2. Turn on the EUT and connect it to measurement instrument. Then set it to any one convenient frequency within its operating range. Set a reference level on the measuring instrument equal to the highest peak value.
3. The center frequency of the spectrum analyzer is set to the fundamental frequency and using 1 MHz RBW and 3 MHz VBW.
4. Measure the frequency difference of two frequencies that were attenuated 20dB from the reference level. Record the frequency difference as the emission bandwidth.
5. Repeat above procedures until all frequencies measured were complete.

#### 4.6.4 DEVIATION FROM TEST STANDARD

No deviation

#### 4.6.5 TEST SETUP

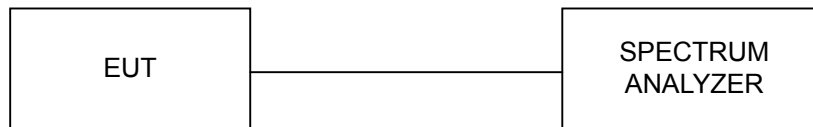

For the actual test configuration, please refer to the related Item – Photographs of the Test Configuration.

#### 4.6.6 EUT OPERATING CONDITION

The software provided by client enabled the EUT to transmit and receive data at lowest, middle and highest channel frequencies individually.

## 4.6.7 TEST RESULTS

<b>EUT</b>	Bluetooth Stereo Headset	<b>MODEL</b>	BSH202
<b>MODULATION TYPE</b>	GFSK	<b>ENVIRONMENTAL CONDITIONS</b>	23 deg. C, 54% RH, 991 hPa
<b>INPUT POWER (SYSTEM)</b>	120Vac, 60 Hz	<b>TESTED BY</b>	Long Chen

CHANNEL	CHANNEL FREQUENCY (MHz)	PEAK POWER OUTPUT (mW)	PEAK POWER OUTPUT (dBm)	PEAK POWER LIMIT (dBm)	PASS/FAIL
0	2402	1.211	0.83	30	PASS
39	2441	0.914	-0.39	30	PASS
78	2480	0.839	-0.76	30	PASS



### Channel 0

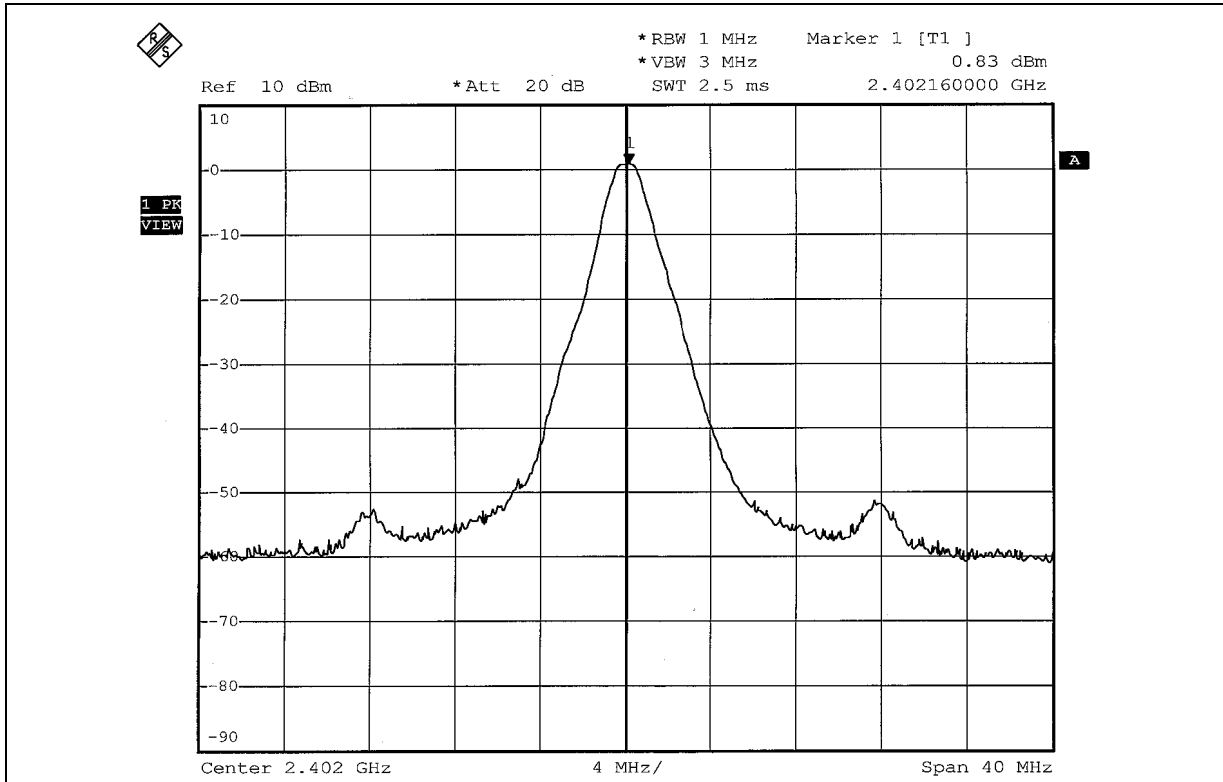

### Channel 39

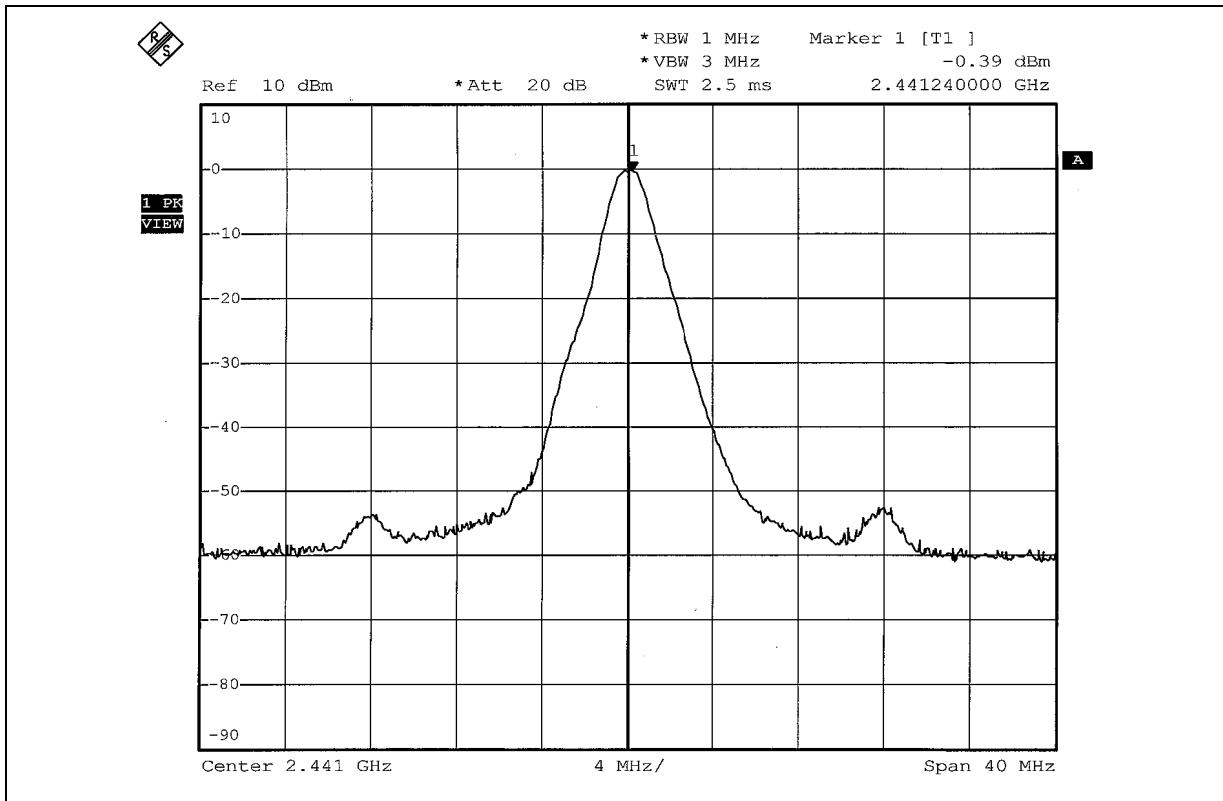



Channel 78

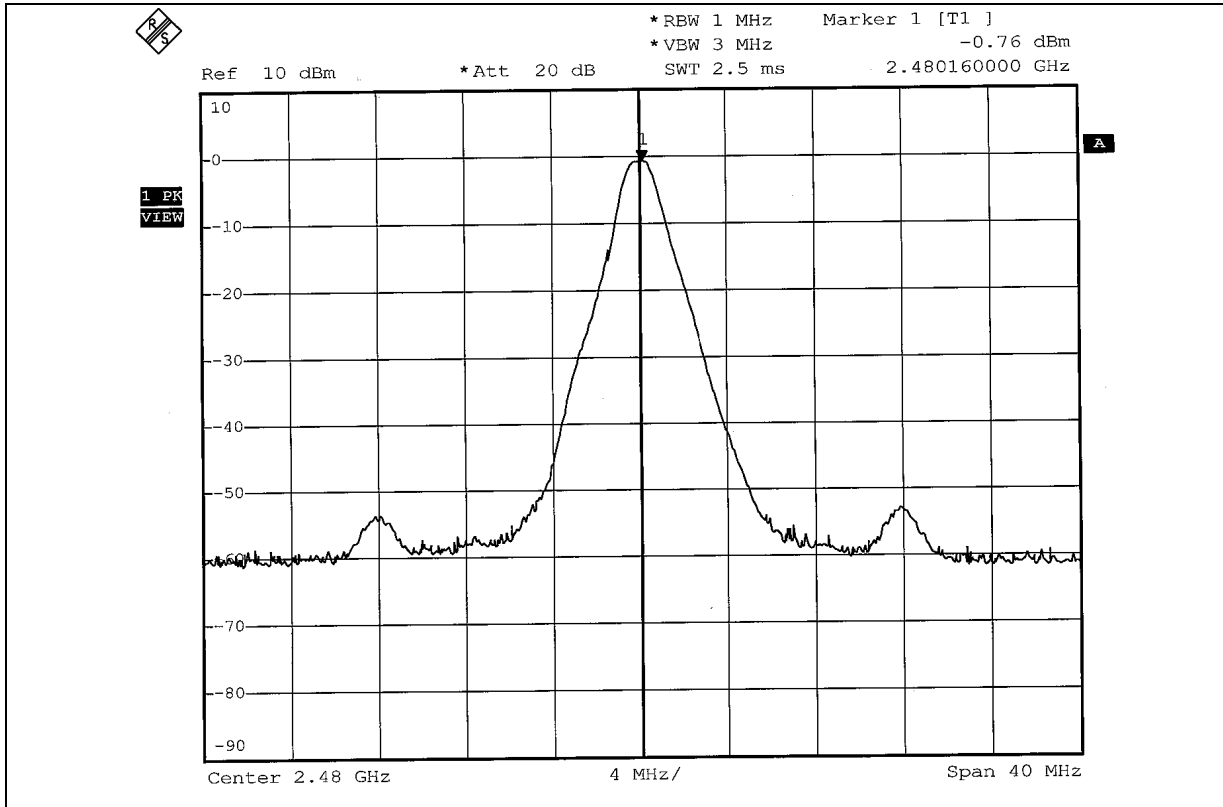

## 4.7 RADIATED EMISSION MEASUREMENT

### 4.7.1 LIMITS OF RADIATED EMISSION MEASUREMENT

Emissions radiated outside of the specified bands, shall be according to the general radiated limits in 15.209 as following:

Frequencies (MHz)	Field strength (microvolts/meter)	Measurement distance (meters)
0.009-0.490	2400/F(kHz)	300
0.490-1.705	24000/F(kHz)	30
1.705-30.0	30	30
30-88	100	3
88-216	150	3
216-960	200	3
Above 960	500	3

**NOTE:** The limit for radiated test was performed according to CISPR 22: 1997, which was specified in FCC PART 15B 15.109(g). Also the limits of ICES-003: 2004 and CISPR 22: 1997 are same.

## 4.7.2 TEST INSTRUMENTS

DESCRIPTION & MANUFACTURER	MODEL NO.	SERIAL NO.	CALIBRATED UNTIL
Test Receiver ROHDE & SCHWARZ	ESI7	838496/016	Jan. 07, 2006
Spectrum Analyzer ROHDE & SCHWARZ	FSP40	100041	Nov. 29, 2005
BILOG Antenna SCHWARZBECK	VULB9168	9168-155	Jan. 22, 2006
HORN Antenna SCHWARZBECK	BBHA 9120D	9120D-404	Jan. 05, 2006
HORN Antenna SCHWARZBECK	BBHA 9170	BBHA 9170242	Jan. 23, 2006
Preamplifier Agilent	8447D	2944A10631	Nov. 17, 2005
Preamplifier Agilent	8449B	3008A01960	Nov. 14, 2005
RF signal cable HUBER+SUHNNER	SUCOFLEX 104	219272/4	Jan. 26, 2006
RF signal cable HUBER+SUHNNER	SUCOFLEX 104	219275/4	Jan. 26, 2006
Software ADT.	ADT_Radiated_V5.14	NA	NA
Antenna Tower inn-co GmbH	MA 4000	010303	NA
Antenna Tower Controller inn-co GmbH	CO2000	019303	NA
Turn Table ADT.	TT100.	TT93021704	NA
Turn Table Controller ADT.	SC100.	SC93021704	NA

- NOTE:**
1. The calibration interval of the above test instruments is 12 months and the calibrations are traceable to NML/ROC and NIST/USA.
  2. The test was performed in HwaYa Chamber 3.
  3. The horn antenna and HP preamplifier (model: 8449B) are used only for the measurement of emission frequency above 1GHz if tested.
  4. The IC Site Registration No. is IC4924-4.

#### 4.7.3 TEST PROCEDURES

- a. The EUT was placed on the top of a rotating table 0.8 meters above the ground at a 3 meters semi-anechoic chamber. The table was rotated 360 degrees to determine the position of the highest radiation.
- b. The EUT was set 3 meters away from the interference-receiving antenna, which was mounted on the top of a variable-height antenna tower.
- c. The antenna is a broadband antenna, and its height is varied from one meter to four meters above the ground to determine the maximum value of the field strength. Both horizontal and vertical polarizations of the antenna are set to make the measurement.
- d. For each suspected emission, the EUT was arranged to its worst case and then the antenna was tuned to heights from 1 meter to 4 meters and the rotatable table was turned from 0 degrees to 360 degrees to find the maximum reading.
- e. The test-receiver system was set to Peak Detect Function and Specified Bandwidth with Maximum Hold Mode.
- f. If the emission level of the EUT in peak mode was 10 dB lower than the limit specified, then testing could be stopped and the peak values of the EUT would be reported. Otherwise the emissions that did not have 10 dB margin would be re-tested one by one using peak, quasi-peak or average method as specified and then reported in a data sheet.

**NOTE:**

1. The resolution bandwidth and video bandwidth of test receiver/spectrum analyzer is 120kHz for Peak detection (PK) and Quasi-peak detection (QP) at frequency below 1GHz.
2. The resolution bandwidth and video bandwidth of test receiver/spectrum analyzer is 1 MHz for Peak detection at frequency above 1GHz.

#### 4.7.4 DEVIATION FROM TEST STANDARD

No deviation.



#### 4.7.5 TEST SETUP

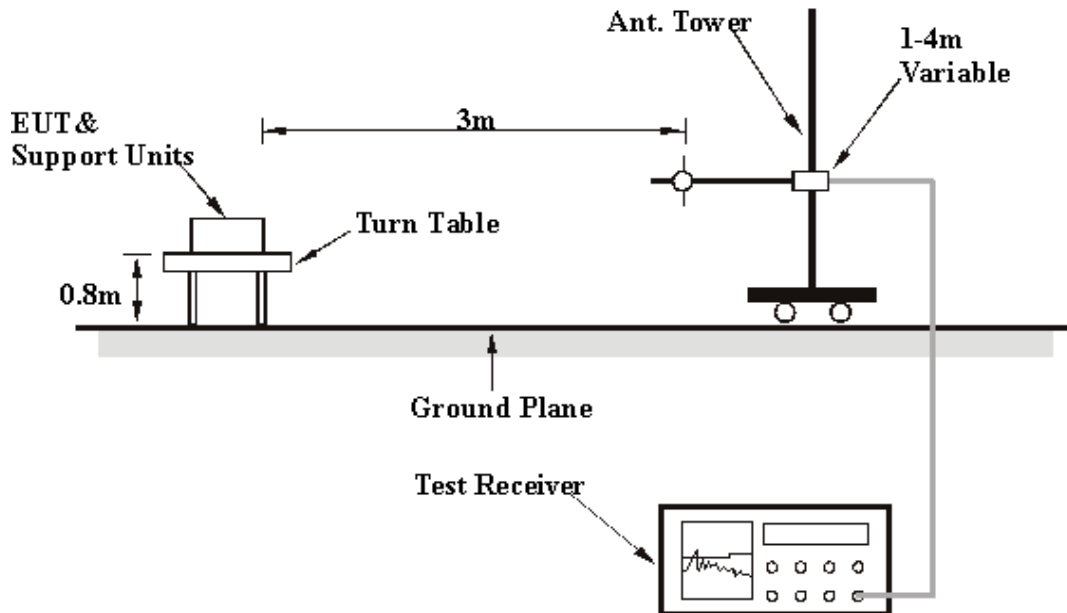

For the actual test configuration, please refer to the related item – Photographs of the Test Configuration.

#### 4.7.6 EUT OPERATING CONDITIONS

- a. EUT turn-on power and placed on a testing table.
- b. The software provided by client enabled the EUT to transmit and receive data at lowest, middle and highest channel frequencies individually.

## 4.7.7 TEST RESULTS

**Below 1GHz Worst-Case Data**

<b>EUT</b>	Bluetooth Stereo Headset	<b>MODEL</b>	BSH202
<b>CHANNEL</b>	78	<b>FREQUENCY RANGE</b>	Below 1 GHz
<b>MODULATION TYPE</b>	GFSK	<b>DETECTOR FUNCTION</b>	Quasi-Peak
<b>INPUT POWER (SYSTEM)</b>	120 Vac, 60 Hz	<b>ENVIRONMENTAL CONDITIONS</b>	23 deg. C, 64% RH, 991 hPa
<b>EUT CONFIGURE MODE</b>	1	<b>TESTED BY</b>	Brad Wu

**ANTENNA POLARITY & TEST DISTANCE: HORIZONTAL AT 3 M**

No.	Freq. (MHz)	Emission Level (dBuV/m)	Limit (dBuV/m)	Margin (dB)	Antenna Height (m)	Table Angle (Degree)	Raw Value (dBuV)	Correction Factor (dB/m)
1	45.55	18.64 QP	40.00	-21.36	1.00 H	67	3.31	15.33
2	764.79	22.43 QP	46.00	-23.57	2.00 H	118	-0.88	23.31
3	797.84	22.69 QP	46.00	-23.31	1.00 H	184	-0.76	23.45
4	844.49	23.14 QP	46.00	-22.86	2.00 H	145	-0.72	23.86
5	893.09	24.14 QP	46.00	-21.86	1.00 H	10	-0.54	24.69
6	949.46	26.72 QP	46.00	-19.28	1.00 H	52	1.39	25.32

**ANTENNA POLARITY & TEST DISTANCE: VERTICAL AT 3 M**

No.	Freq. (MHz)	Emission Level (dBuV/m)	Limit (dBuV/m)	Margin (dB)	Antenna Height (m)	Table Angle (Degree)	Raw Value (dBuV)	Correction Factor (dB/m)
1	45.55	20.55 QP	40.00	-19.45	1.00 V	256	5.22	15.33
2	84.43	24.03 QP	40.00	-15.97	1.25 V	133	14.06	9.97
3	743.41	22.53 QP	46.00	-23.47	1.00 V	151	-0.55	23.08
4	836.71	22.99 QP	46.00	-23.01	1.00 V	154	-0.80	23.79
5	896.97	25.00 QP	46.00	-21.00	2.00 V	304	0.24	24.76
6	945.57	25.90 QP	46.00	-20.10	2.00 V	253	0.62	25.28

- REMARKS:**
1. Emission level(dBuV/m)=Raw Value(dBuV) + Correction Factor(dB/m)
  2. Correction Factor(dB/m) = Antenna Factor (dB/m) + Cable Factor (dB)
  3. The other emission levels were very low against the limit.
  4. Margin value = Emission level – Limit value.

<b>EUT</b>	Bluetooth Stereo Headset	<b>MODEL</b>	BSH202
<b>CHANNEL</b>	78	<b>FREQUENCY RANGE</b>	Below 1 GHz
<b>MODULATION TYPE</b>	GFSK	<b>DETECTOR FUNCTION</b>	Quasi-Peak
<b>INPUT POWER (SYSTEM)</b>	120 Vac, 60 Hz	<b>ENVIRONMENTAL CONDITIONS</b>	23 deg. C, 64% RH, 991 hPa
<b>EUT CONFIGURE MODE</b>	2	<b>TESTED BY</b>	Brad Wu

#### ANTENNA POLARITY & TEST DISTANCE: HORIZONTAL AT 3 M

No.	Freq. (MHz)	Emission Level (dBuV/m)	Limit (dBuV/m)	Margin (dB)	Antenna Height (m)	Table Angle (Degree)	Raw Value (dBuV)	Correction Factor (dB/m)
1	45.55	18.87 QP	40.00	-21.13	2.00 H	301	3.54	15.33
2	162.18	28.22 QP	43.50	-15.28	2.00 H	340	13.50	14.72
3	825.05	23.65 QP	46.00	-22.35	1.00 H	202	-0.03	23.69
4	871.70	24.03 QP	46.00	-21.97	1.25 H	232	-0.27	24.30
5	910.58	24.51 QP	46.00	-21.49	1.00 H	142	-0.41	24.92
6	947.52	24.98 QP	46.00	-21.02	1.00 H	46	-0.33	25.30

#### ANTENNA POLARITY & TEST DISTANCE: VERTICAL AT 3 M

No.	Freq. (MHz)	Emission Level (dBuV/m)	Limit (dBuV/m)	Margin (dB)	Antenna Height (m)	Table Angle (Degree)	Raw Value (dBuV)	Correction Factor (dB/m)
1	45.55	21.28 QP	40.00	-18.72	1.00 V	232	5.95	15.33
2	84.43	22.12 QP	40.00	-17.88	2.00 V	346	12.15	9.97
3	834.77	23.70 QP	46.00	-22.30	2.00 V	10	-0.07	23.77
4	883.37	23.66 QP	46.00	-22.34	2.00 V	136	-0.85	24.51
5	928.08	23.94 QP	46.00	-22.06	2.00 V	88	-1.16	25.10
6	959.18	25.13 QP	46.00	-20.87	1.00 V	208	-0.23	25.36

- REMARKS:**
1. Emission level(dBuV/m)=Raw Value(dBuV) + Correction Factor(dB/m)
  2. Correction Factor(dB/m) = Antenna Factor (dB/m) + Cable Factor (dB)
  3. The other emission levels were very low against the limit.
  4. Margin value = Emission level – Limit value.

<b>EUT</b>	Bluetooth Stereo Headset	<b>MODEL</b>	BSH202
<b>CHANNEL</b>	78	<b>FREQUENCY RANGE</b>	Below 1 GHz
<b>MODULATION TYPE</b>	GFSK	<b>DETECTOR FUNCTION</b>	Quasi-Peak
<b>INPUT POWER (SYSTEM)</b>	120 Vac, 60 Hz	<b>ENVIRONMENTAL CONDITIONS</b>	23 deg. C, 64% RH, 991 hPa
<b>EUT CONFIGURE MODE</b>	3	<b>TESTED BY</b>	Brad Wu

#### ANTENNA POLARITY & TEST DISTANCE: HORIZONTAL AT 3 M

No.	Freq. (MHz)	Emission Level (dBuV/m)	Limit (dBuV/m)	Margin (dB)	Antenna Height (m)	Table Angle (Degree)	Raw Value (dBuV)	Correction Factor (dB/m)
1	45.55	17.90 QP	40.00	-22.10	1.00 H	67	2.57	15.33
2	739.52	22.69 QP	46.00	-23.31	2.00 H	79	-0.29	22.98
3	828.94	23.04 QP	46.00	-22.96	2.00 H	13	-0.68	23.72
4	877.54	23.96 QP	46.00	-22.04	1.00 H	100	-0.45	24.41
5	910.58	24.84 QP	46.00	-21.16	1.00 H	337	-0.08	24.92
6	955.29	25.11 QP	46.00	-20.89	2.00 H	139	-0.24	25.35

#### ANTENNA POLARITY & TEST DISTANCE: VERTICAL AT 3 M

No.	Freq. (MHz)	Emission Level (dBuV/m)	Limit (dBuV/m)	Margin (dB)	Antenna Height (m)	Table Angle (Degree)	Raw Value (dBuV)	Correction Factor (dB/m)
1	70.82	22.60 QP	40.00	-17.40	1.00 V	271	10.33	12.27
2	113.59	21.16 QP	43.50	-22.34	1.00 V	130	8.92	12.23
3	817.27	23.45 QP	46.00	-22.55	2.00 V	280	-0.17	23.62
4	873.65	23.87 QP	46.00	-22.13	1.00 V	130	-0.46	24.34
5	916.41	26.74 QP	46.00	-19.26	2.00 V	19	1.76	24.98
6	953.35	25.12 QP	46.00	-20.88	2.00 V	187	-0.22	25.34

- REMARKS:**
1. Emission level(dBuV/m)=Raw Value(dBuV) + Correction Factor(dB/m)
  2. Correction Factor(dB/m) = Antenna Factor (dB/m) + Cable Factor (dB)
  3. The other emission levels were very low against the limit.
  4. Margin value = Emission level – Limit value.

**1 ~ 25GHz Worst-Case Data**

<b>EUT</b>	Bluetooth Stereo Headset	<b>MODEL</b>	BSH202
<b>CHANNEL</b>	0	<b>FREQUENCY RANGE</b>	1 ~ 25 GHz
<b>MODULATION TYPE</b>	GFSK	<b>DETECTOR FUNCTION</b>	Peak(PK) Average (AV)
<b>INPUT POWER (SYSTEM)</b>	120 Vac, 60 Hz	<b>ENVIRONMENTAL CONDITIONS</b>	23 deg. C, 64% RH, 991 hPa
<b>TESTED BY</b>	Brad Wu		

**ANTENNA POLARITY & TEST DISTANCE: HORIZONTAL AT 3 M**

No.	Freq. (MHz)	Emission Level (dBuV/m)	Limit (dBuV/m)	Margin (dB)	Antenna Height (m)	Table Angle (Degree)	Raw Value (dBuV)	Correction Factor (dB/m)
1	2390.00	45.61 PK	74.00	-28.39	1.39 H	322	13.74	31.87
2	*2402.00	100.71 PK			1.39 H	322	68.79	31.92
2	*2402.00	70.71 AV			1.39 H	322	38.79	31.92
3	3604.00	48.34 PK	74.00	-25.66	1.00 H	124	13.74	34.60
3	3604.00	39.95 AV	54.00	-14.05	1.00 H	124	5.35	34.60
4	7206.00	57.24 PK	74.00	-16.76	1.03 H	173	13.05	44.19
<b>4</b>	<b>7206.00</b>	<b>48.89 AV</b>	<b>54.00</b>	<b>-5.11</b>	<b>1.03 H</b>	<b>173</b>	<b>4.70</b>	<b>44.19</b>

**ANTENNA POLARITY & TEST DISTANCE: VERTICAL AT 3 M**

No.	Freq. (MHz)	Emission Level (dBuV/m)	Limit (dBuV/m)	Margin (dB)	Antenna Height (m)	Table Angle (Degree)	Raw Value (dBuV)	Correction Factor (dB/m)
1	2390.00	40.65 PK	74.00	-33.35	1.20 V	266	8.78	31.87
2	*2402.00	95.75 PK			1.20 V	266	63.83	31.92
2	*2402.00	65.75 AV			1.20 V	266	33.83	31.92
3	3604.00	48.32 PK	74.00	-25.68	1.01 V	338	13.72	34.60
3	3604.00	37.14 AV	54.00	-16.86	1.01 V	338	2.54	34.60
4	7206.00	56.38 PK	74.00	-17.62	1.02 V	261	12.19	44.19
4	7206.00	46.09 AV	54.00	-7.91	1.02 V	261	1.90	44.19

- REMARKS:**
1. Emission level(dBuV/m)=Raw Value(dBuV) + Correction Factor(dB/m)
  2. Correction Factor(dB/m) = Antenna Factor (dB/m) + Cable Factor (dB)
  3. The other emission levels were very low against the limit.
  4. Margin value = Emission level – Limit value.
  5. " \* " : Fundamental frequency
  6. The DH5 packet was the worse case duty cycle for a transmit dwell time on a channel, based upon bluetooth theory the transmitter is on 0.625\*5 per 247 ms per channel. Therefore, the duty cycle be equal to:  $20\log(3.125/100) = -30$  dB
  7. Average value = peak reading  $-20\log(\text{duty cycle})$



<b>EUT</b>	Bluetooth Stereo Headset	<b>MODEL</b>	BSH202
<b>CHANNEL</b>	39	<b>FREQUENCY RANGE</b>	1 ~ 25 GHz
<b>MODULATION TYPE</b>	GFSK	<b>DETECTOR FUNCTION</b>	Peak(PK) Average (AV)
<b>INPUT POWER (SYSTEM)</b>	120 Vac, 60 Hz	<b>ENVIRONMENTAL CONDITIONS</b>	23 deg. C, 64% RH, 991 hPa
<b>TESTED BY</b>	Brad Wu		

<b>ANTENNA POLARITY &amp; TEST DISTANCE: HORIZONTAL AT 3 M</b>								
No.	Freq. (MHz)	Emission Level (dBuV/m)	Limit (dBuV/m)	Margin (dB)	Antenna Height (m)	Table Angle (Degree)	Raw Value (dBuV)	Correction Factor (dB/m)
1	*2441.00	98.76 PK			1.37 H	324	66.69	32.07
1	*2441.00	68.76 AV			1.37 H	324	36.69	32.07
2	3662.00	48.69 PK	74.00	-25.31	1.04 H	193	13.93	34.76
3	7323.00	55.48 PK	74.00	-18.52	1.06 H	188	10.94	44.54
3	7323.00	46.72 AV	54.00	-7.28	1.06 H	188	2.18	44.54

<b>ANTENNA POLARITY &amp; TEST DISTANCE: VERTICAL AT 3 M</b>								
No.	Freq. (MHz)	Emission Level (dBuV/m)	Limit (dBuV/m)	Margin (dB)	Antenna Height (m)	Table Angle (Degree)	Raw Value (dBuV)	Correction Factor (dB/m)
1	*2441.00	94.59 PK			1.15 V	266	62.52	32.07
1	*2441.00	64.59 AV			1.15 V	266	32.52	32.07
2	3662.00	47.28 PK	74.00	-26.72	1.06 V	347	12.52	34.76
3	7323.00	55.46 PK	74.00	-18.54	1.04 V	213	10.92	44.54
3	7323.00	45.22 AV	54.00	-8.78	1.04 V	213	0.68	44.54

- REMARKS:**
1. Emission level(dBuV/m)=Raw Value(dBuV) + Correction Factor(dB/m)
  2. Correction Factor(dB/m) = Antenna Factor (dB/m) + Cable Factor (dB)
  3. The other emission levels were very low against the limit.
  4. Margin value = Emission level – Limit value.
  5. “ \* “ : Fundamental frequency
  6. The DH5 packet was the worse case duty cycle for a transmit dwell time on a channel, based upon bluetooth theory the transmitter is on 0.625\*5 per 247 ms per channel. Therefore, the duty cycle be equal to:  $20\log(3.125/100) = -30$  dB
  7. Average value = peak reading  $-20\log(\text{duty cycle})$

<b>EUT</b>	Bluetooth Stereo Headset	<b>MODEL</b>	BSH202
<b>CHANNEL</b>	78	<b>FREQUENCY RANGE</b>	1 ~ 25 GHz
<b>MODULATION TYPE</b>	GFSK	<b>DETECTOR FUNCTION</b>	Peak(PK) Average (AV)
<b>INPUT POWER (SYSTEM)</b>	120 Vac, 60 Hz	<b>ENVIRONMENTAL CONDITIONS</b>	23 deg. C, 64% RH, 991 hPa
<b>TESTED BY</b>	Brad Wu		

#### ANTENNA POLARITY & TEST DISTANCE: HORIZONTAL AT 3 M

No.	Freq. (MHz)	Emission Level (dBuV/m)	Limit (dBuV/m)	Margin (dB)	Antenna Height (m)	Table Angle (Degree)	Raw Value (dBuV)	Correction Factor (dB/m)
1	*2480.00	98.61 PK			1.38 H	325	66.38	32.23
1	*2480.00	68.61 AV			1.38 H	325	36.38	32.23
2	2483.50	46.99 PK	74.00	-27.01	1.38 H	325	14.75	32.24
3	3722.00	47.29 PK	74.00	-26.71	1.02 H	189	12.38	34.91
4	7440.00	52.19 PK	74.00	-21.81	1.00 H	184	7.37	44.82
4	7440.00	42.37 AV	54.00	-11.63	1.00 H	184	-2.45	44.82

#### ANTENNA POLARITY & TEST DISTANCE: VERTICAL AT 3 M

No.	Freq. (MHz)	Emission Level (dBuV/m)	Limit (dBuV/m)	Margin (dB)	Antenna Height (m)	Table Angle (Degree)	Raw Value (dBuV)	Correction Factor (dB/m)
1	*2480.00	93.33 PK			1.16 V	204	61.10	32.23
1	*2480.00	63.33 AV			1.16 V	204	31.10	32.23
2	2483.50	41.71 PK	74.00	-32.29	1.16 V	204	9.47	32.24
3	3722.00	47.45 PK	74.00	-26.55	1.05 V	349	12.54	34.91
4	7440.00	54.39 PK	74.00	-19.61	1.00 V	274	9.57	44.82
4	7440.00	44.52 AV	54.00	-9.48	1.00 V	274	-0.30	44.82

- REMARKS:**
1. Emission level(dBuV/m)=Raw Value(dBuV) + Correction Factor(dB/m)
  2. Correction Factor(dB/m) = Antenna Factor (dB/m) + Cable Factor (dB)
  - 3The other emission levels were very low against the limit.
  4. Margin value = Emission level – Limit value.
  5. " \* " : Fundamental frequency
  6. The DH5 packet was the worse case duty cycle for a transmit dwell time on a channel, based upon bluetooth theory the transmitter is on 0.625\*5 per 247 ms per channel. Therefore, the duty cycle be equal to:  $20\log(3.125/100) = -30$  dB
  7. Average value = peak reading  $-20\log(\text{duty cycle})$

## 4.8 BAND EDGES MEASUREMENT

### 4.8.1 LIMITS OF BAND EDGES MEASUREMENT

Below -20dB of the highest emission level of operating band (in 100KHz RBW).

### 4.8.2 TEST INSTRUMENTS

Description & Manufacturer	Model No.	Serial No.	Calibrated Until
SPECTRUM ANALYZER	FSEK30	100049	Aug. 12, 2005

**NOTE:**

The calibration interval of the above test instruments is 12 months. And the calibrations are traceable to NML/ROC and NIST/USA.

### 4.8.3 TEST PROCEDURE

The transmitter output was connected to the spectrum analyzer via a low lose cable. Set both RBW and VBW of spectrum analyzer to 100 kHz with suitable frequency span including 100 MHz bandwidth from band edge. The band edges was measured and recorded.

### 4.8.4 DEVIATION FROM TEST STANDARD

No deviation



#### 4.8.5 EUT OPERATING CONDITION

The software provided by client enabled the EUT to transmit and receive data at lowest, middle and highest channel frequencies individually.

#### 4.8.6 TEST RESULTS

The spectrum plots are attached on the following 4 images. D2 line indicates the highest level, D1 line indicates the 20dB offset below D2. It shows compliance with the requirement in part 15.247(d).

**NOTE 1:** The band edge emission plot on page 48 shows 56.18dBc between carrier maximum power and local maximum emission in restrict band (2.3900GHz). The emission of carrier strength list in the test result of channel 0 at the item 4.7.7 is 100.71dBuV/m (Peak), so the maximum field strength in restrict band is  $100.71 - 56.18 = 44.53$  dBuV/m which is under 74 dBuV/m limit.

The band edge emission plot on page 48 shows 56.18dBc between carrier maximum power and local maximum emission in restrict band (2.3900GHz). The emission of carrier strength list in the test result of channel 0 at the item 4.7.7 is 70.71dBuV/m (Average), so the maximum field strength in restrict band is  $70.71 - 56.18 = 14.53$  dBuV/m which is under 54 dBuV/m limit.

**NOTE 2:** The band edge emission plot on page 49 shows 54.49dBc between carrier maximum power and local maximum emission in restrict band (2.4920GHz). The emission of carrier strength list in the test result of channel 78 at the item 4.7.7 is 98.61dBuV/m (Peak), so the maximum field strength in restrict band is  $98.61 - 54.49 = 44.12$  dBuV/m which is under 74 dBuV/m limit.

The band edge emission plot on page 49 shows 54.49dBc between carrier maximum power and local maximum emission in restrict band (2.4920GHz). The emission of carrier strength list in the test result of channel 78 at the item 4.7.7 is 68.61dBuV/m (Average), so the maximum field strength in restrict band is  $68.61 - 54.49 = 14.12$  dBuV/m which is under 54 dBuV/m limit.

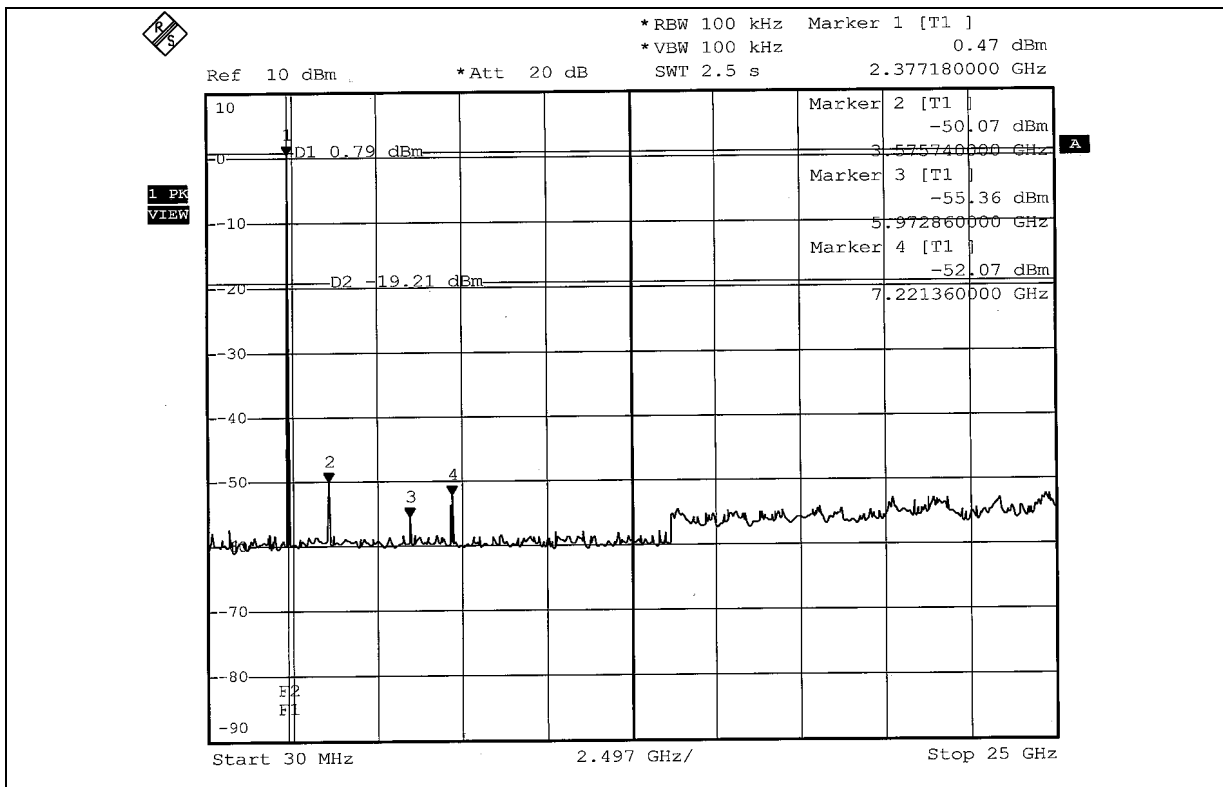
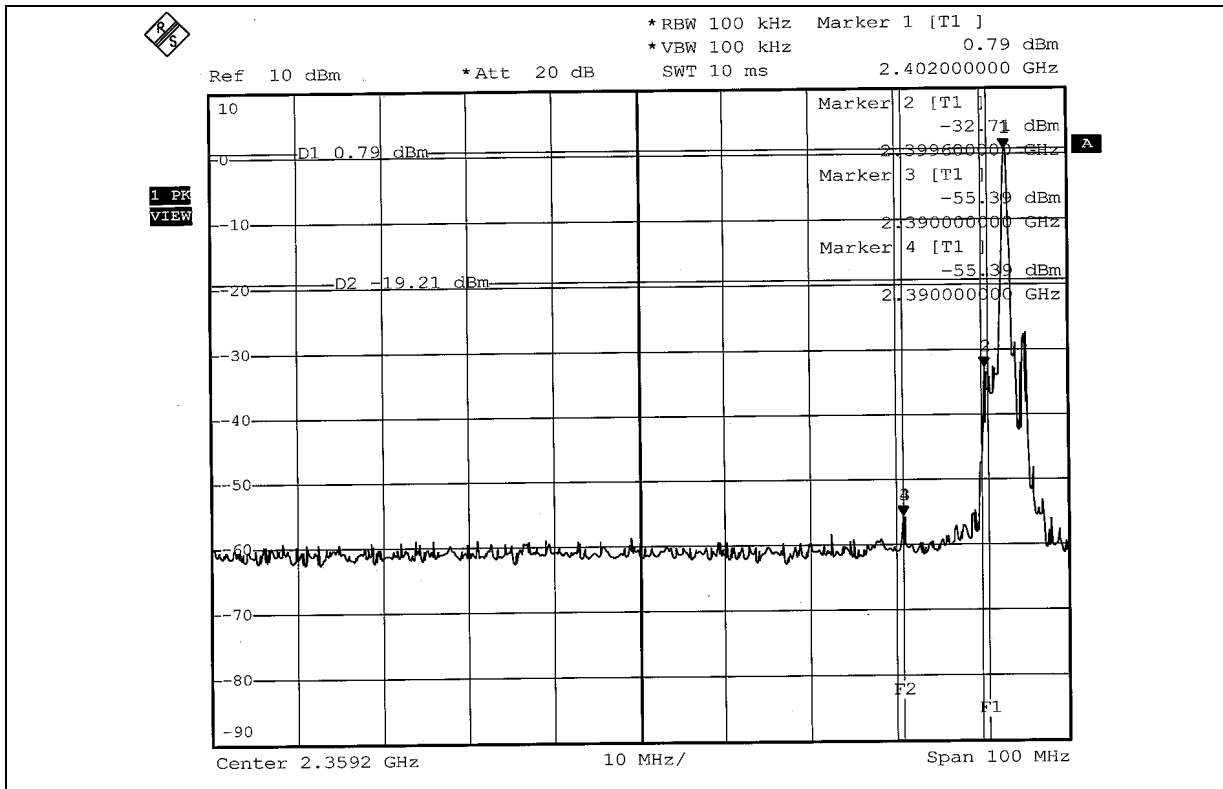

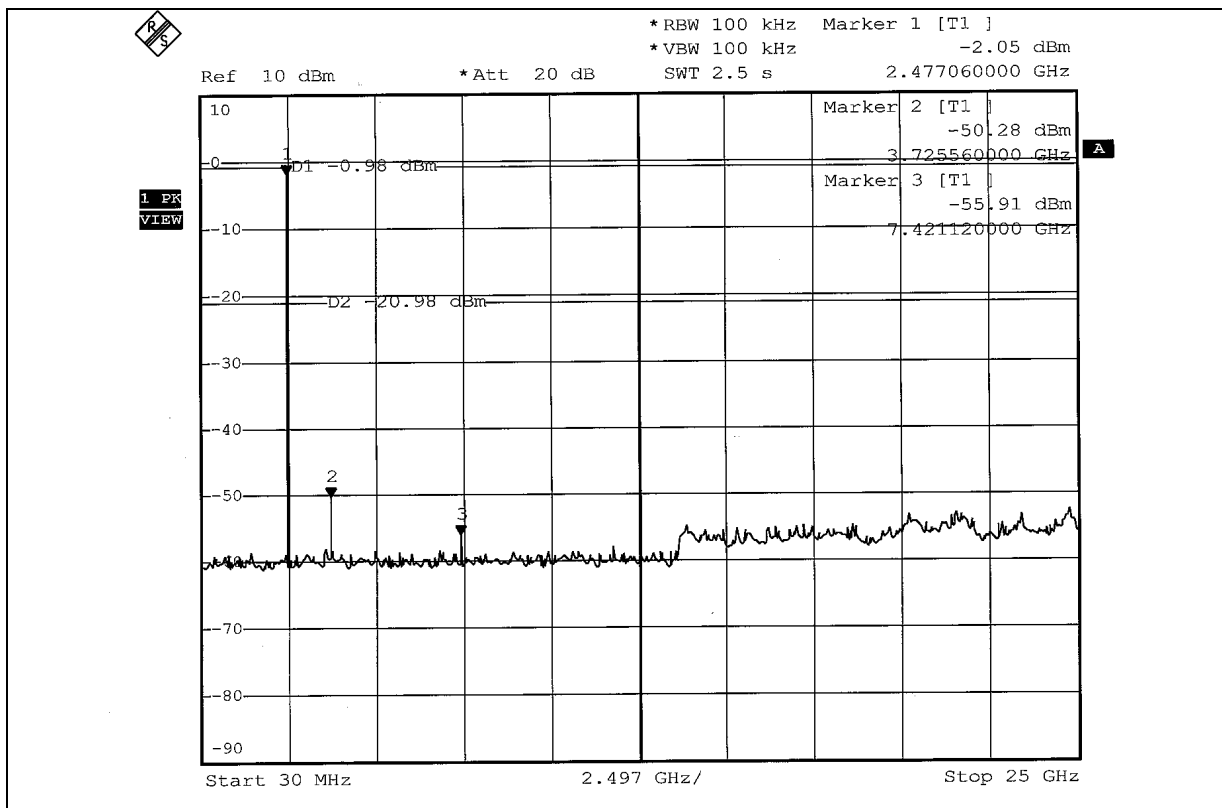
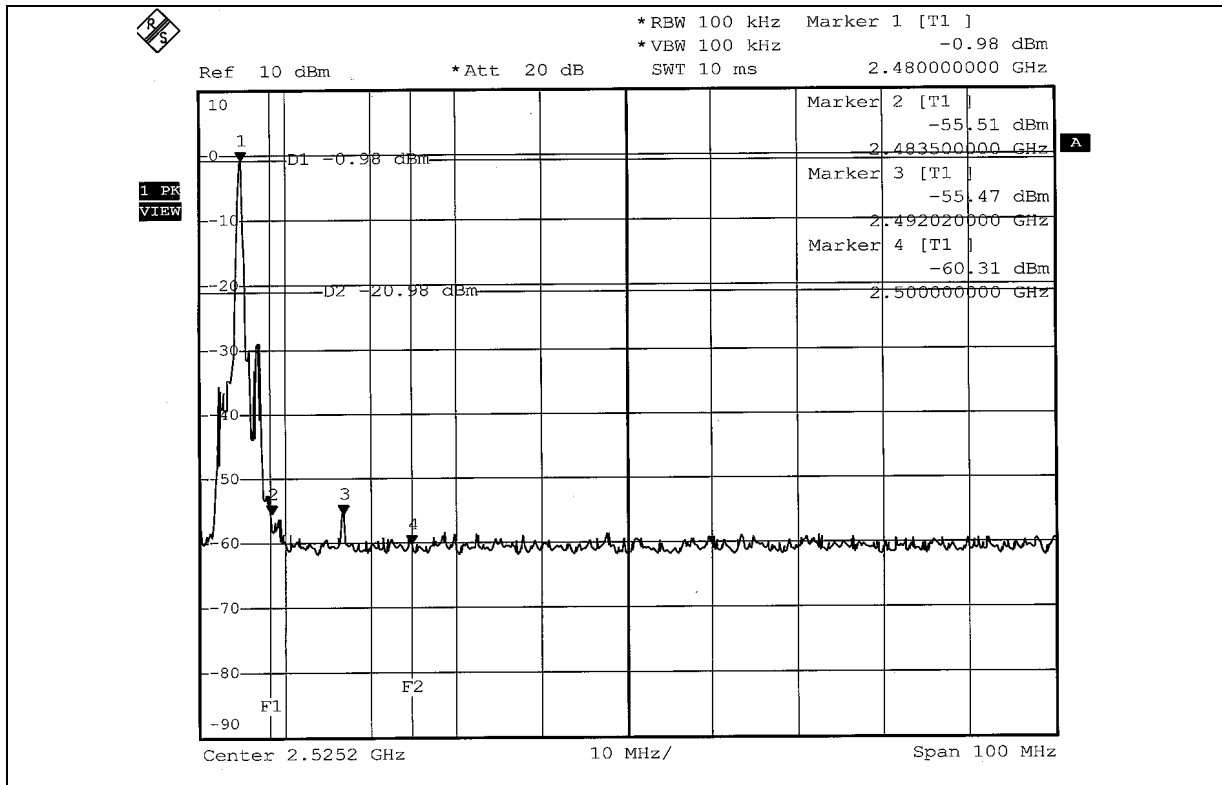



## **4.9 ANTENNA REQUIREMENT**

### **4.9.1 STANDARD APPLICABLE**

For intentional device, according to FCC 47 CFR Section 15.203, an intentional radiator shall be designed to ensure that no antenna other than that furnished by the responsible party shall be used with the device.

And according to FCC 47 CFR Section 15.247 (b), if transmitting antennas of directional gain greater than 6 dBi are used, the power shall be reduced by the amount in dB that the directional gain of the antenna exceeds 6 dBi.

### **4.9.2 ANTENNA CONNECTED CONSTRUCTION**

The antenna used in this product is Chip antenna without antenna connector. The maximum gain of this antenna is 1dBi.

### 5 PHOTOGRAPHS OF THE TEST CONFIGURATION

Test Mode 1

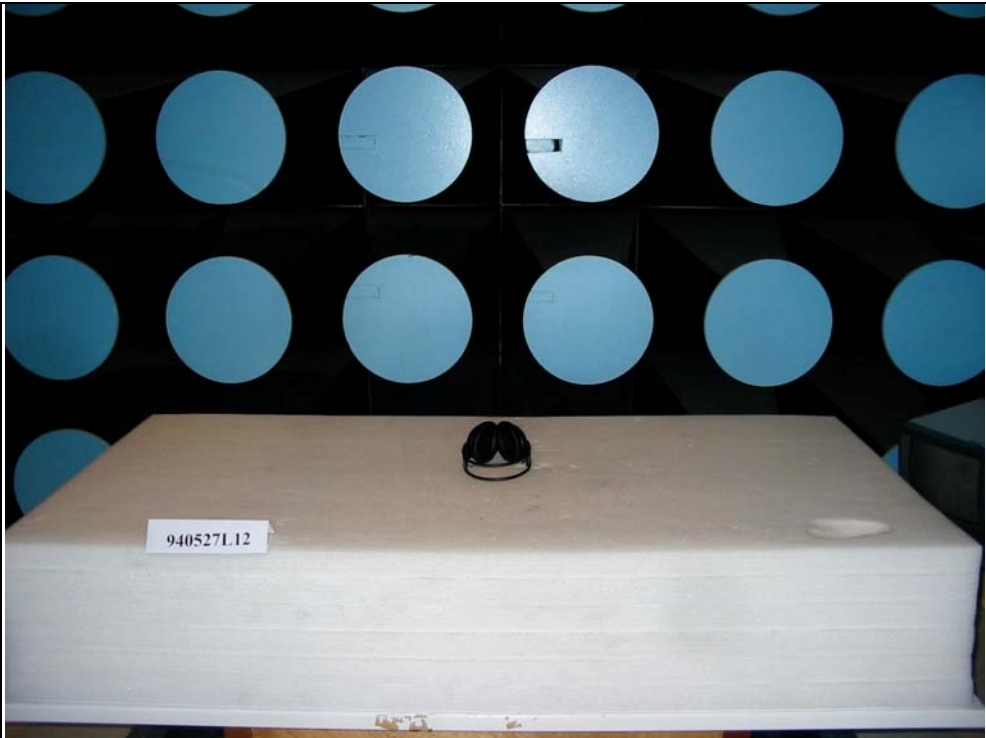
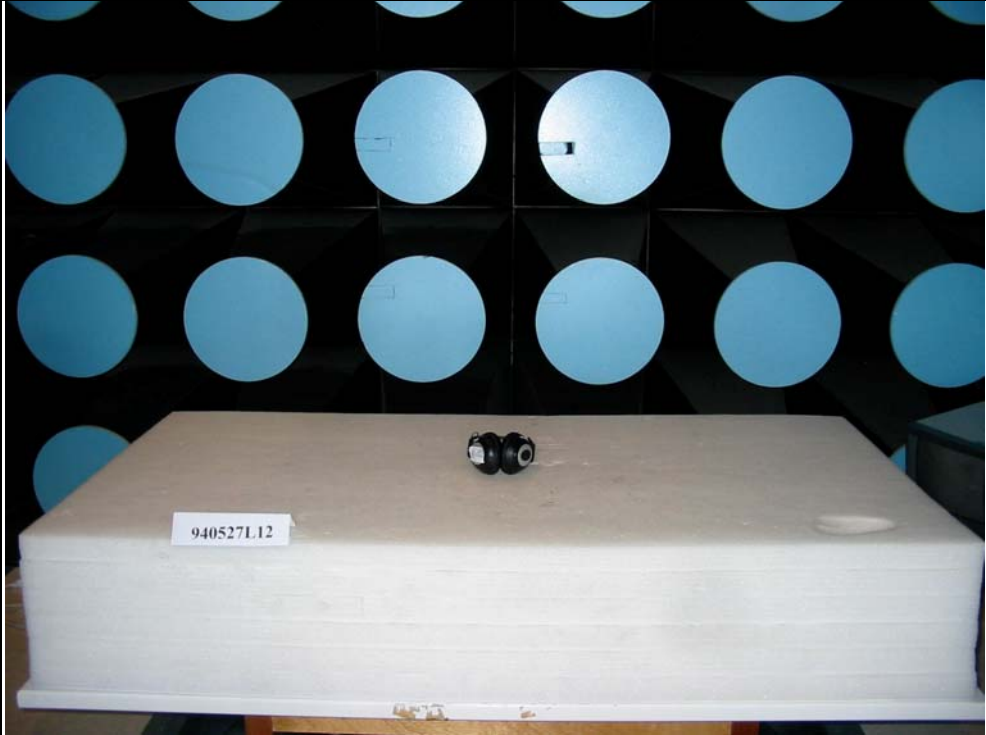

Test Mode 2



Test Mode 3

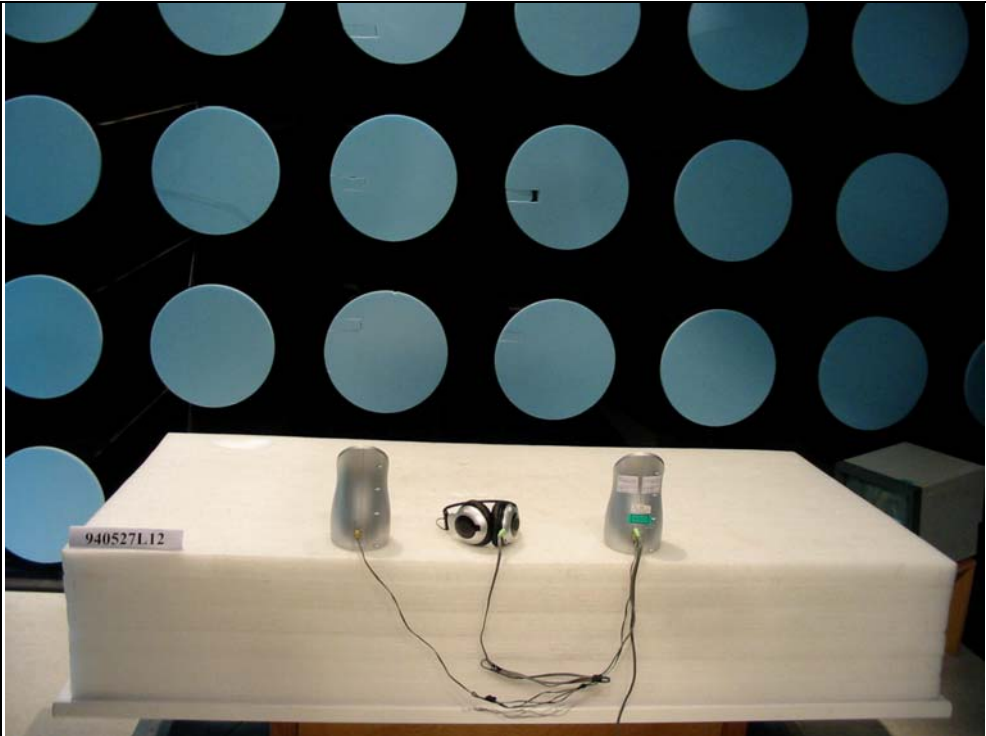



## 6 INFORMATION ON THE TESTING LABORATORIES

We, ADT Corp., were founded in 1988 to provide our best service in EMC, Radio, Telecom and Safety consultation. Our laboratories are accredited and approved by the following approval agencies according to ISO/IEC 17025.

<b>USA</b>	FCC, NVLAP, UL, A2LA
<b>Germany</b>	TUV Rheinland
<b>Japan</b>	VCCI
<b>Norway</b>	NEMKO
<b>Canada</b>	INDUSTRY CANADA , CSA
<b>R.O.C.</b>	CNLA, BSMI, DGT
<b>Netherlands</b>	Telefication
<b>Singapore</b>	PSB , GOST-ASIA(MOU)
<b>Russia</b>	CERTIS(MOU)

Copies of accreditation certificates of our laboratories obtained from approval agencies can be downloaded from our web site: [www.adt.com.tw/index.5/phtml](http://www.adt.com.tw/index.5/phtml).  
If you have any comments, please feel free to contact us at the following:

**Linko EMC/RF Lab:**

Tel: 886-2-26052180  
Fax: 886-2-26052943

**Hsin Chu EMC/RF Lab:**

Tel: 886-3-5935343  
Fax: 886-3-5935342

**Hwa Ya EMC/RF/Safety/Telecom Lab:**

Tel: 886-3-3183232  
Fax: 886-3-3185050

**Linko RF Lab.**

Tel: 886-3-3270910  
Fax: 886-3-3270892

**Web Site:** [www.adt.com.tw](http://www.adt.com.tw)

The address and road map of all our labs can be found in our web site also.