



849 NW STATE ROAD 45  
 NEWBERRY, FL 32669 USA  
 PH: 888.472.2424 OR  
 352.472.5500  
 FAX: 352.472.2030  
 EMAIL: [INFO@TIMCOENGR.COM](mailto:INFO@TIMCOENGR.COM)  
[HTTP://WWW.TIMCOENGR.COM](http://WWW.TIMCOENGR.COM)

**FCC PART 95  
 GMRS TRANSCEIVER  
 TEST REPORT**

<b>APPLICANT</b>	MIDLAND RADIO CORPORATION
	5900 PARRETTA DRIVE KANSAS CITY MISSOURI 64120 USA
<b>FCC ID</b>	MMAMXT105
<b>PRODUCT DESCRIPTION</b>	MOBILE GMRS TRANSCEIVER
<b>FCC STANDARD APPLIED</b>	47 CFR § 95 Personal Radio Service Subpart A - General Mobile Radio Service (GMRS)
<b>DATE SAMPLE RECEIVED</b>	5/12/2016
<b>FINAL TEST DATE</b>	6/20/2016
<b>TESTED BY</b>	Tim Royer
<b>APPROVED BY</b>	Cory Leverett
<b>TEST RESULTS</b>	<input checked="" type="checkbox"/> PASS <input type="checkbox"/> FAIL

Report Number	Version Number	Description	Issue Date
816AUT16TestReport_	Rev1	Initial Issue	5/27/2016
816AUT16TestReport_	Rev2	Updated Report	6/9/2016
816AUT16TestReport	Rev3	Updated Report	6/20/2016
816AUT16TestReport	Rev4	Corrected Requirements on Page 16.	6/20/2016

**THE ATTACHED REPORT SHALL NOT BE REPRODUCED EXCEPT IN FULL  
 WITHOUT THE WRITTEN APPROVAL OF TIMCO ENGINEERING, INC.**

## Table of Contents

GENERAL REMARKS .....	3
GENERAL INFORMATION.....	4
TEST PROCEDURES.....	5
TEST REPORT SUMMARY.....	8
EMISSION DESIGNATOR AND FREQUENCIES .....	9
RF POWER OUTPUT.....	10
Test Data: 462.625 11K0F3E Measurement Table.....	10
MODULATION CHARACTERISTICS.....	11
Test Data: 462.625 11K0F3E Audio Response Plot.....	11
Test Data: 462.625 11K0F3E Modulation Limiting Plot.....	12
Test Data: 462.625 11K0F3E Low Pass Filter Plot .....	13
OCCUPIED BANDWIDTH .....	14
Test Data: 462.625 11K0F3E Emission Mask Plot .....	14
SPURIOUS EMISSIONS AT ANTENNA TERMINALS (CONDUCTED).....	14
Test Data: 462.625 11K0F3E Measurement Table.....	15
FIELD STRENGTH OF SPURIOUS EMISSIONS.....	16
Test Data : 462.625 11K0F3E Measurement Table.....	16
FREQUENCY STABILITY .....	17
EMC EQUIPMENT LIST .....	18

**GENERAL REMARKS**

The attached report shall not be reproduced except in full without the written permission of Timco Engineering Inc.

The test results relate only to the items tested.

**Summary**

The device under test does:

- Fulfill the general approval requirements as identified in this test report
- Not fulfill the general approval requirements as identified in this test report

**Attestations**

This equipment has been tested in accordance with the standards identified in this test report. To the best of my knowledge and belief, these tests were performed using the measurement procedures described in this report.

All instrumentation and accessories used to test products for compliance to the indicated standards are calibrated regularly in accordance with ISO 17025: 2005 requirements.

I attest that the necessary measurements were made at:

**Timco Engineering Inc.  
849 NW State Road 45  
Newberry, FL 32669**

**Authorized Signatory Name:**



Tim Royer  
Engineering Project Manager

**Date: 6/20/2016**



Test report reviewed and approved by: \_\_\_\_\_

Cory Leverett, Timco Engineering, Inc.

**Date: 06/20/2016**

**GENERAL INFORMATION**  
**EUT Specification**

<b>EUT Description</b>	MOBILE GMRS TRANSCEIVER
<b>EUT Application</b>	Portable short range communications
<b>FCC ID</b>	MMAMXT105
<b>Serial Number</b>	N/A
<b>Operating Frequency</b>	GMRS:462.5500-462.7250 MHz
<b>Test Frequencies</b>	GMRS: 462.625 MHz
<b>No. of Channels</b>	18
<b>Type of Emission</b>	11K0F3E
<b>EUT Power Source</b>	<input type="checkbox"/> 110-120Vac/50-60Hz (Optional AC power Adapter)
	<input checked="" type="checkbox"/> DC Power 13.8V
	<input type="checkbox"/> Battery Operated Exclusively
<b>Test Item</b>	<input type="checkbox"/> Prototype
	<input type="checkbox"/> Pre-Production
	<input checked="" type="checkbox"/> Production
<b>Type of Equipment</b>	<input type="checkbox"/> Fixed
	<input checked="" type="checkbox"/> Mobile
	<input type="checkbox"/> Portable
<b>Antenna</b>	Fixed
<b>Test Conditions</b>	The temperature was 26°C with a relative humidity of 50-60%.
<b>Modification to the EUT</b>	None
<b>Test Exercise</b>	The EUT was placed in continuous transmit mode of operation
<b>Applicable Standards</b>	ANSI/TIA 603-D:2010, FCC CFR 47 Part 95

## TEST PROCEDURES

**General:** The test procedures used are detailed in **ANSI/TIA 603-D**.

**Power Output:** RF power was conducted per ANSI/TIA 603-D using a Spectrum analyzer and Attenuator

**Bandwidth:** The measurements were made with the spectrum analyzer's resolution bandwidth (RBW) = 1 MHz and the video bandwidth (VBW) = 3 MHz and the span set as shown on plot.

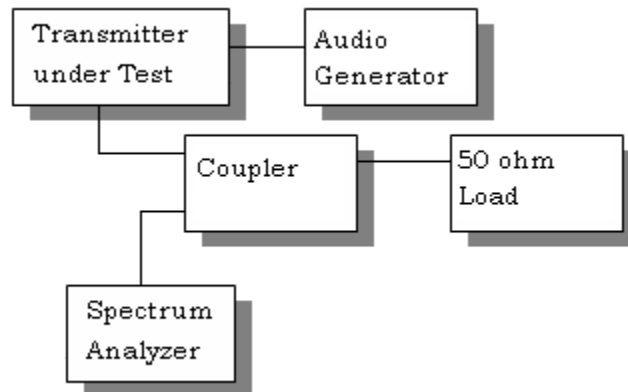

**Antenna Conducted Emissions:** The RBW = 100 kHz, VBW = 300 kHz and the span set to 10.0 MHz and the spectrum was scanned from 30 MHz to the 10<sup>th</sup> Harmonic of the fundamental. Above 1 GHz the resolution bandwidth was 1 MHz and the VBW = 3 MHz and the span to 50 MHz.

## TEST PROCEDURES

**Radiation Interference:** The test procedure used was ANSI/TIA 603-D using a Rohde & Schwartz Spectrum Analyzer with pre-selector. The bandwidth (RBW) of the spectrum receiver was 100 kHz up to 1 GHz and 1 MHz above 1 GHz with an appropriate sweep speed. The VBW above 1 GHz was 3 MHz. The analyzer was calibrated in dB above a microvolt at the output of the antenna.

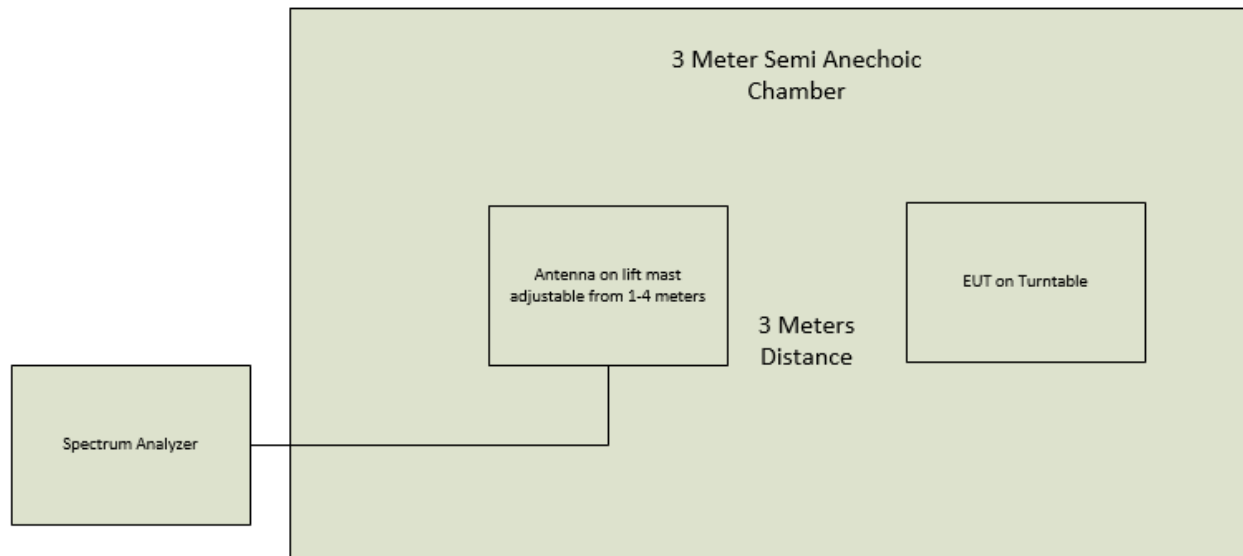

## TEST PROCEDURES:

**Frequency Stability:** The EUT was placed into a temperature chamber. After a reference frequency is measured at room temperature, The EUT frequency is measured at the required extreme temperatures after a 20 minute soak time at each said temperature. The EUT antenna output port was connected to a frequency counter for the frequency measurement of an unmodulated CW signal. The voltage was also varied + and - 15% with a variable DC power supply and the frequency measured and compared to the reference frequency.

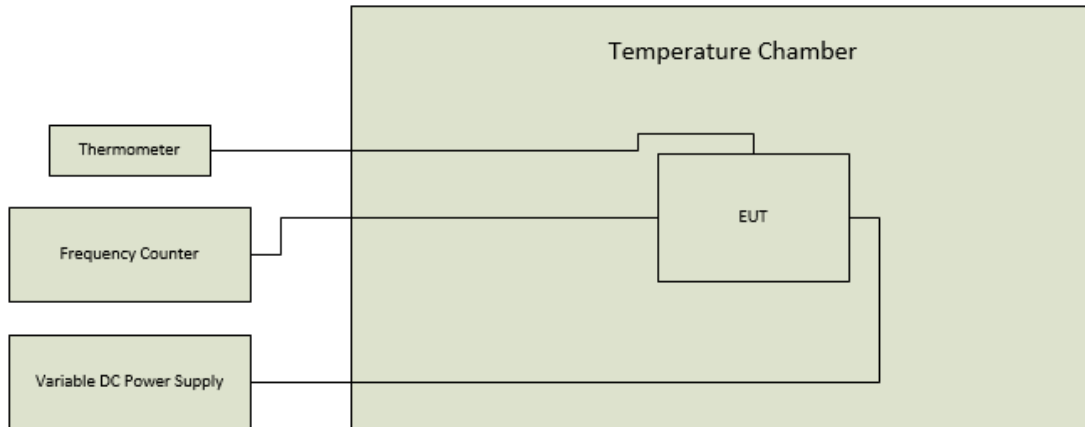

## TEST REPORT SUMMARY

Rule Part No.	Scope of Work	Status Pass/Fail/NA
<a href="#">Part 2.1033(c)(6)(7), Part 2.1046(a), PART 95 Subpart A</a>	RF Power Output	Pass
<a href="#">Part 2.1033(a) (b)</a>	Modulation Characteristics	Pass
<a href="#">2.1049(c), 95.635(b)(1)(3)(7)</a>	Emission Mask and Occupied Bandwidths	Pass
<a href="#">2.1051</a>	Antenna Conducted Emissions	Pass
<a href="#">2.1053, 95.635(b)(7)</a>	Field Strength Spurious Emissions	Pass
<a href="#">Part 2.1055 Part 95.621(b)</a>	Frequency Stability	Pass



## EMISSION DESIGNATOR AND FREQUENCIES

[2.1033© \(4\)](#) Type of Emission: 11K0F3E  
[95.631](#)

$B_n = 2M + 2DK$   
 $M = 3000$   
 $D = 2.5K$   
 $B_n = 2(3000) + 2(2500) = 11K$

GMRS Authorized Bandwidth 12.5 kHz

[2.1033© \(5\)](#) GMRS Allowed Channel frequencies (MHz):  
[95.621 \(a\)](#)

- |              |              |
|--------------|--------------|
| 1. 462.5500  | 13. 462.7000 |
| 2. 462.5625  | 14. 462.7125 |
| 3. 462.5750  | 15. 462.7250 |
| 4. 462.5875  |              |
| 5. 462.6000  |              |
| 6. 462.6125  |              |
| 7. 462.6250  |              |
| 8. 462.6375  |              |
| 9. 462.6500  |              |
| 10. 462.6625 |              |
| 11. 462.6750 |              |
| 12. 462.6875 |              |

**RF POWER OUTPUT**

**Rule Part No.:** [FCC Part 2.1033\(c\)\(6\)\(7\), FCC Part 2.1046\(a\), FCC PART 95 Subpart A,](#)

**Requirements:** There can be no provisions for increasing the power or varying the power. No GMRS channel, under any condition of modulation, shall exceed:

1. 50W Carrier power (average TP during one modulated RF cycle) when transmitting emissions type A1D, F1D, G1D, A3E, F3E, or G3E.
2. 50W peak envelope TP when transmitting emission type H1D, J1D, R1D, H3E, J3E, or R3E.

**Method of Measurement:** Conducted at the antenna port using a Spectrum Analyzer and Attenuator. With a nominal battery voltage and the transmitter properly adjusted the RF output measures:

**Test Data: 462.625 11K0F3E Measurement Table**

Output power

GMRS	36.9 dBm	4.89W
------	-------------	-------

**Rule Part No.: 2.1033 (C) (8) DC Input into the final amplifier**

Power Input = 19.2 Watts

DC Power Consumption

Vdc = 13.94 volts

Ic = 1.377 amps

Results: Pass

## MODULATION CHARACTERISTICS

### [Part 2.1033\(a\) \(b\)](#)

#### Requirements:

#### Method of Measurement:

The audio frequency response was measured in accordance with ANSI/TIA 603-D. The audio frequency response curve is shown below. The audio signal was fed into a dummy microphone circuit and into the microphone connector. The input required to produce 30 percent modulation level was measured.

#### Test Data: 462.625 11K0F3E Audio Response Plot

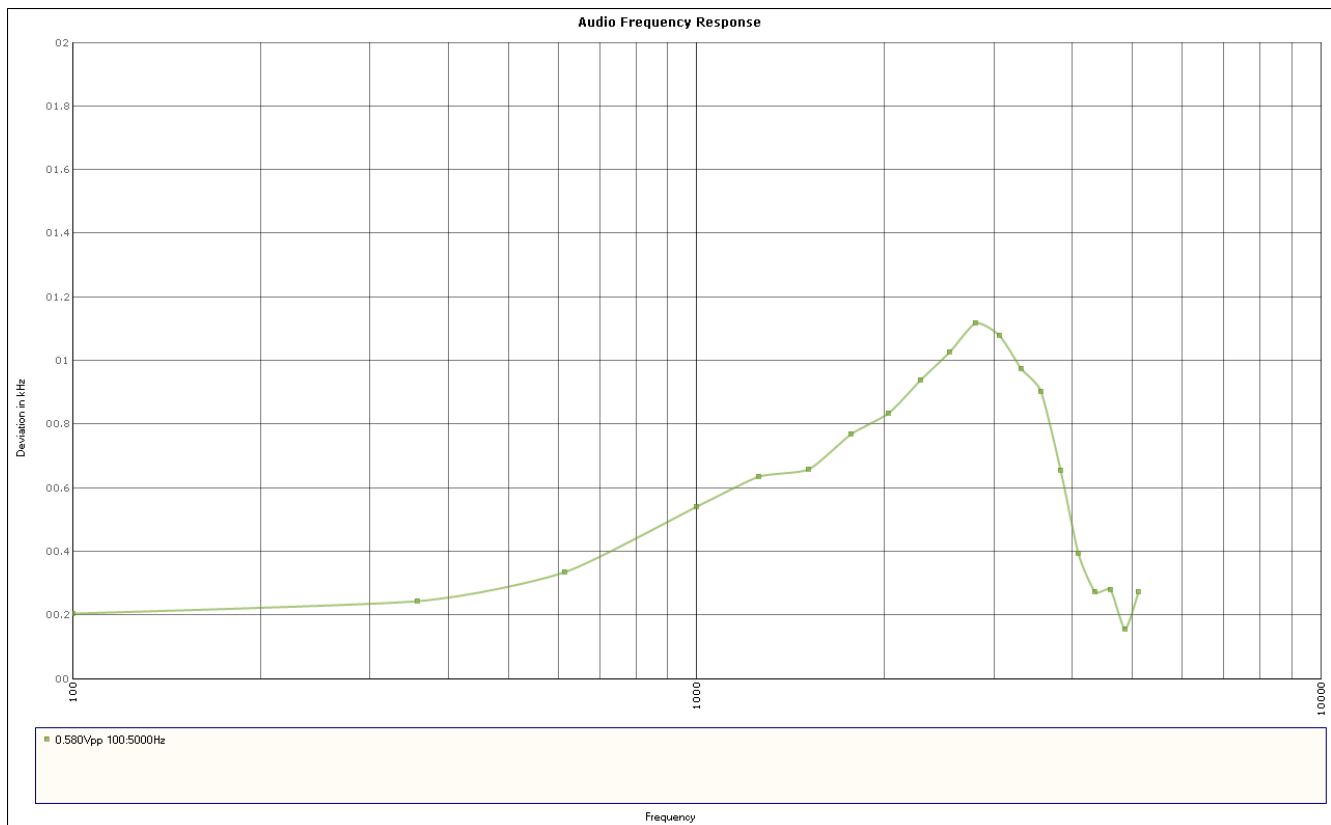

## Audio input versus modulation

The audio input level needed for a particular percentage of modulation was measured in accordance with ANSI/TIA 603-D. Curves are provided for audio input frequencies of 300, 1000, and 2500 Hz. See the plot below.

### Test Data: 462.625 11K0F3E Modulation Limiting Plot

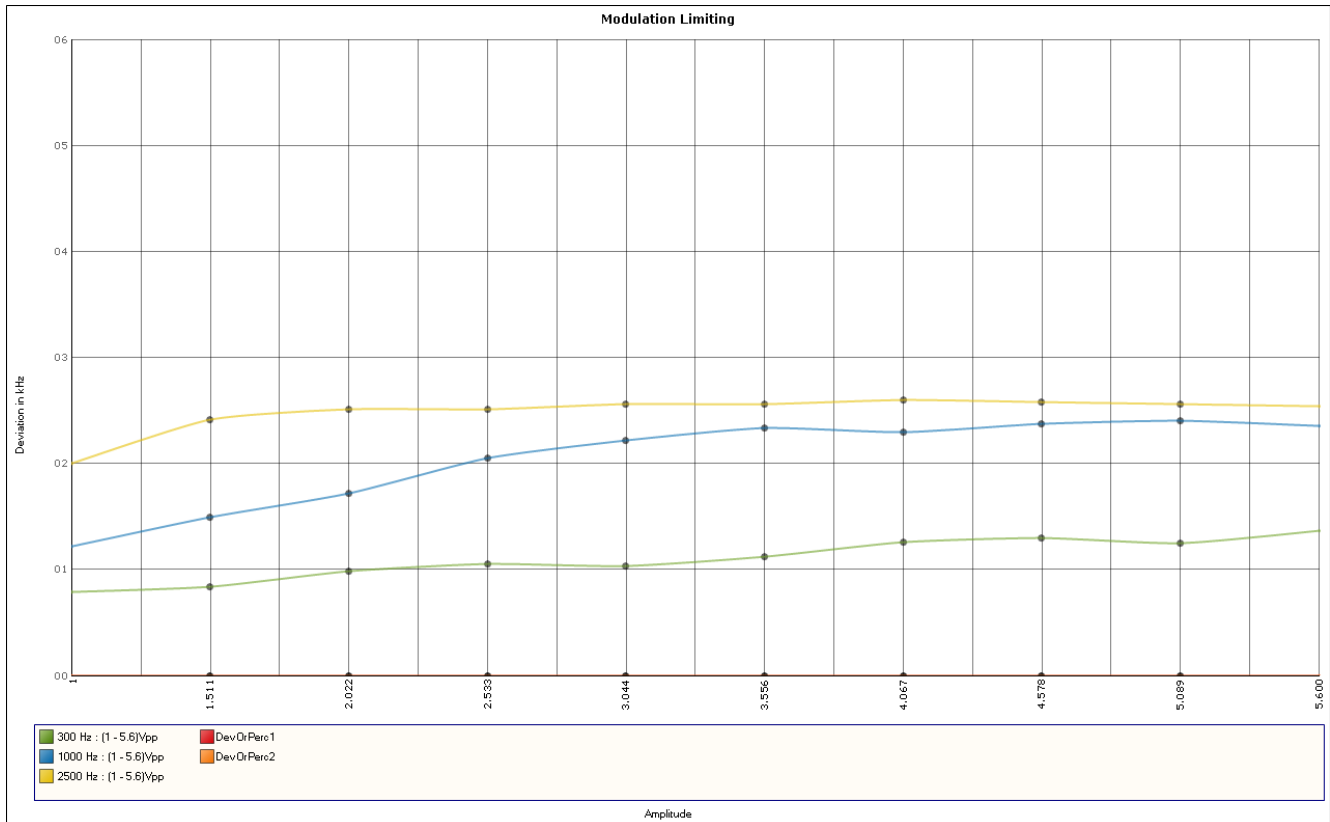

## Post Limiter Filter

Each GMRS transmitter, except a mobile station transmitter with a power output of 2.5 W or less, must automatically prevent a greater than normal audio level from causing over modulation. The transmitter also must include audio frequency low pass filtering, unless it complies with the applicable paragraphs of §95.631 (without filtering.) The filter must be between the modulation limiter and the modulated stage of the transmitter. At any frequency (f in kHz) between 3 and 20 kHz, the filter must have an attenuation of at least  $60 \log_{10}(f/3)$  dB greater than the attenuation at 1 kHz. Above 20 kHz, it must have an attenuation of at least 50 dB greater than the attenuation at 1 kHz.

### Test Data: 462.625 11K0F3E Low Pass Filter Plot

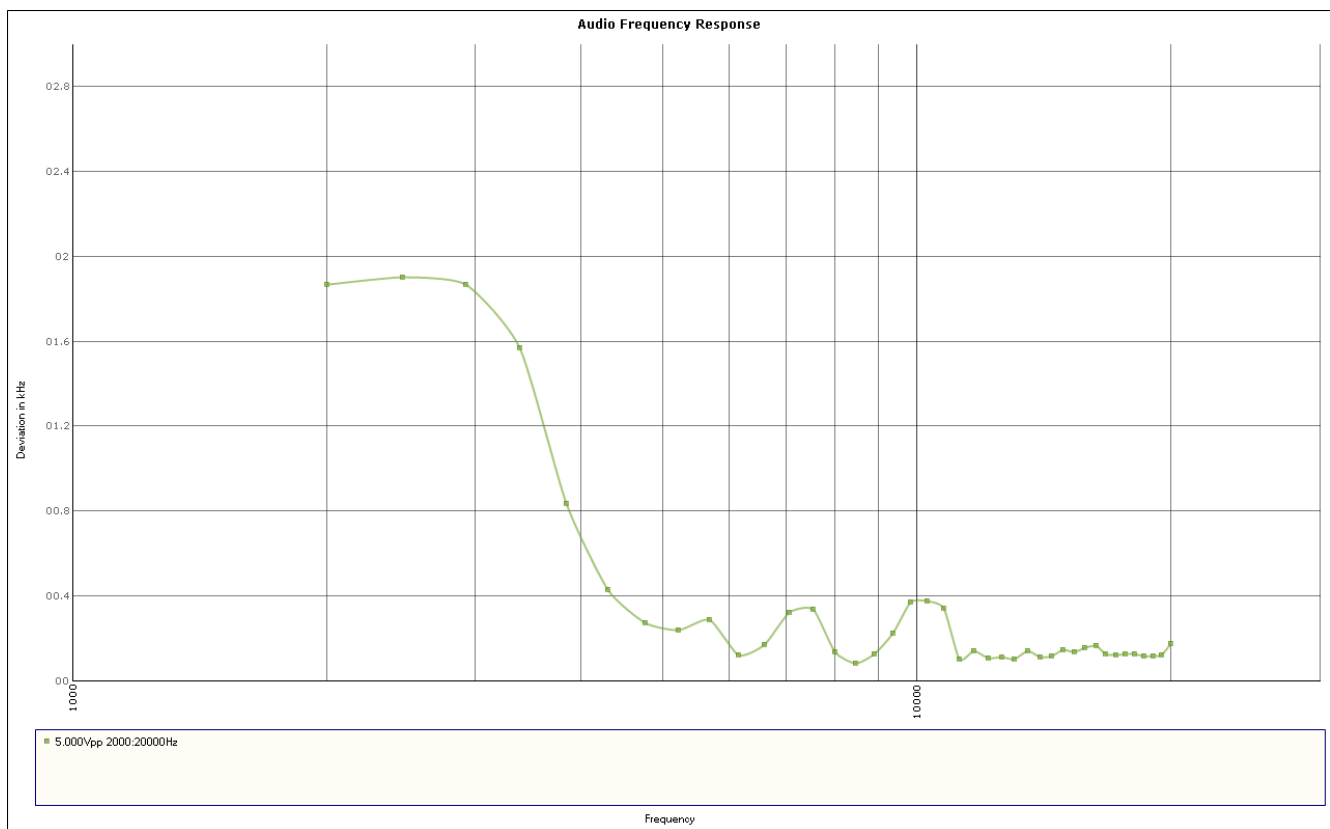

**Results: PASS**

## OCCUPIED BANDWIDTH

Part 2.1049(c) EMISSION BANDWIDTH:  
[95.635\(b\) \(1\) \(3\) \(7\)](#)

At least 25 dB on any frequency removed from the center of the authorized bandwidth by more than 50% up to and including 100% of the authorized bandwidth. At least 35 dB on any frequency removed from the center of the authorized BW by more than 100% up to and including 250% of the authorized BW. At least 43+log<sub>10</sub> (TP) dB on any frequency removed from the center of the authorized bandwidth by more than 250%. See the following plot.

**Test procedure:** ANSI/TIA-603-D paragraph 2.2.11.

### Test Data: 462.625 11K0F3E Emission Mask Plot

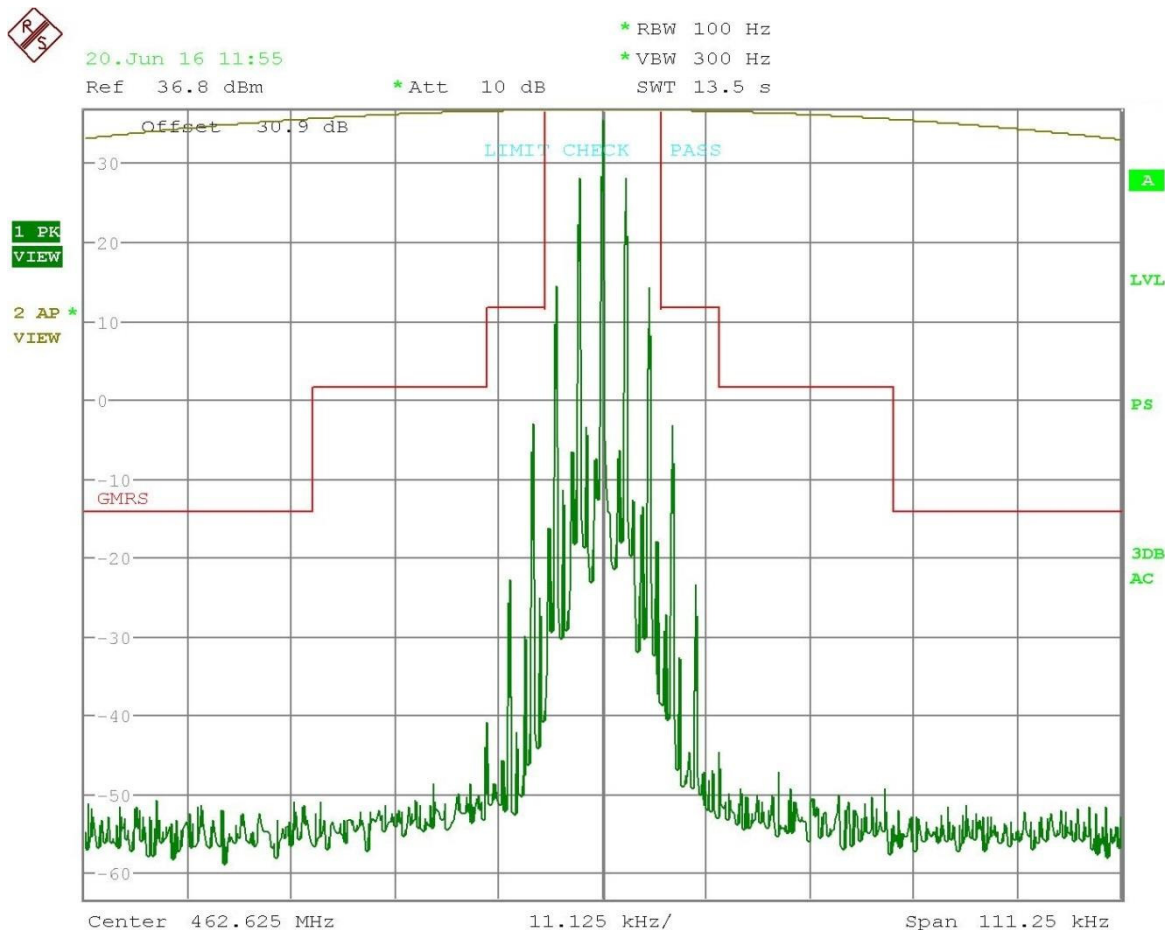

Date: 20.JUN.2016 11:55:40

### Results Meet Requirements

Applicant: MIDLAND RADIO CORPORATION  
 FCC ID: MMAMXT105  
 Report: 816AUT16TestReport\_Rev4

[Table of Contents](#)

## SPURIOUS EMISSIONS AT ANTENNA TERMINALS (CONDUCTED)

**Rule Part No.:** Part 2.1051(a), 95.635(b) (7)

### Method of Measuring Conducted Spurious Emissions

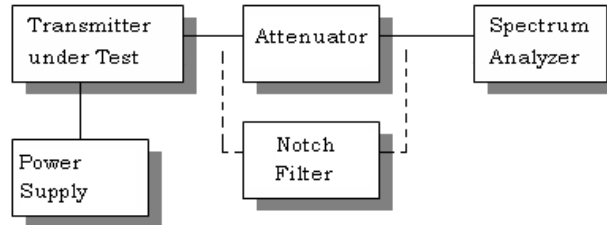

**Requirements:** Greater than 250% removed =  $43 + 10 \log(4.9) = 49.9$  dBc

**Method of Measurement:** The carrier was modulated 100% using a 2500 Hz tone. The spectrum was scanned from 0.4 to at least the 10th harmonic of the fundamental. The measurements were made in accordance with standard ANSI/TIA 603-D.

### Test Data: 462.625 11K0F3E Measurement Table

	dBm	dBm	Watts
Power Output	36.9	36.9	4.9
	Frequency	dBm	dBc
	462.623	36.9	0
	925.246	-35.9	72.8
	1387.869	-59.5	96.4
	1850.492	-89.67	126.57
	2313.115	-89.67	126.57
	2775.738	-89.67	126.57
	3238.361	-89.67	126.57
	3700.984	-89.67	126.57
	4163.607	-89.67	126.57
	4626.23	-89.67	126.57

## FIELD STRENGTH OF SPURIOUS EMISSIONS

**Rule Parts. No.:** [FCC Part 2.1053](#), [95.635\(b\) \(7\)](#), [IC RSS-210](#)

**Requirements:** GMRS:  $43 + 10\log(4.9) = 49.9\text{dB}$

**METHOD OF MEASUREMENT:** The tabulated data shows the results of the radiated field strength emissions test. The spectrum was scanned from 30 MHz to at least the tenth harmonic of the fundamental. This test was conducted per ANSI/TIA 603-D: 2010 using the substitution method. Only the worst case for each antenna polarity is shown.

### Test Data : 462.625 11K0F3E Measurement Table

Emission Frequency (MHz)	Power Mode	Conducted Power Output (dBm)	Conducted Power Output (Watts)	FCC Requirement dB	Bandwidth - BW - kHz
462.62	Hi	36.90	4.90	49.90	12.5
Emission Frequency (MHz)	Ant. Polarity		Below Carrier (dBc)	Margin	
925.25	H		80.72	30.82	
1,387.88	H		79.84	29.94	
1,850.50	H		75.59	25.69	
2,313.13	H		72.88	22.98	
2,775.75	V		73.38	23.48	
3,238.38	H		71.38	21.48	
3,701.00	H		68.22	18.32	
4,163.63	V		67.75	17.85	
4,626.25	H		76.40	26.50	



## FREQUENCY STABILITY

**Rule Parts. No.:** [FCC Part 2.1055](#) [Part 95.621\(b\)](#), [IC RSS-210](#)

**Requirements:** Temperature and voltage tests were performed to verify that the frequency remains within the 0.0005%, 5 ppm specification limit. The test was conducted as follows: The transmitter was placed in the temperature chamber at 25° C and allowed to stabilize for one hour. The transmitter was keyed ON for one minute during which four frequency readings were recorded at 15 second intervals. The worst case number was taken for temperature plotting. The assigned channel frequency was considered to be the reference frequency. The temperature was then reduced to -30° C after which the transmitter was again allowed to stabilize for one hour. The transmitter was keyed ON for one minute, and again frequency readings were noted at 15 second intervals. The worst case number was recorded for temperature plotting. This procedure was repeated in 10 degree increments up to + 50° C.

**Method of Measurements:** ANSI/TIA 603-D

### Test Data:

Temperature	Frequency MHz	Cycles	PPM
25°C (reference)	462.62491		
-30°C	462.62552	610	1.319
-20°C	462.62475	-160	-0.346
-10°C	462.62456	-350	-0.757
0°C	462.62472	-190	-0.411
10°C	462.62481	-100	-0.216
20°C	462.62484	-70	-0.151
30°C	462.62482	-90	-0.195
40°C	462.62478	-130	-0.281
50°C	462.62469	-220	-0.476
Battery Voltage	Frequency	Cycles	PPM
-15%	462.62458	-330	-0.713
15%	462.62469	-220	-0.476

Note: This EUT meets the frequency stability requirement for a GMRS frequency stability requirements: +/- 5ppm over the temp range -30 degrees C to +50 degrees C.

## EMC EQUIPMENT LIST

Device	Manufacturer	Model	Serial Number	Cal/Char Date	Due Date
Antenna: Biconnical	Eaton	94455-1	1096	07/14/15	07/14/17
Antenna: Log-Periodic	Electro-Metrics	LPA-25	1122	07/14/15	07/14/17
Temperature Chamber	Tenney Engineering	TTRC	11717-7	08/19/14	08/19/16
AC Voltmeter	HP	400FL	2213A14499	07/01/15	07/01/17
Frequency Counter	HP	5352B	2632A00165	07/01/15	07/01/17
CHAMBER	Panashield	3M	N/A	01/05/16	12/31/17
Antenna: Double-Ridged Horn/ETS Horn 2	ETS-Lindgren Chamber	3117	00041534	02/25/15	02/25/17
EMI Test Receiver R & S ESIB 40	Rohde & Schwarz	ESIB 40	100274	08/12/14	08/12/16
Field Strength Program	Timco	N/A	Version 4.0 NO	12/12/99	12/12/99
Antenna: Active Loop	ETS-Lindgren	6502	00062529	11/18/15	11/18/17
Attenuator N 10dB 20W	Narda	766-10	0010 (#8)	05/18/15	05/18/17
Hygro-Thermometer	Extech	445703	0602	06/30/15	06/30/17
Type K J Thermometer	Martel	303	080504494	10/26/15	10/26/17
Modulation Analyzer	HP	8901A	3050A05856	04/16/15	04/16/17
EMI Test Receiver R & S ESU 40	Rohde & Schwarz	ESU 40	100320	04/01/16	04/01/18
Attenuator N 20dB 20W	Narda	768-20-SP	344 (#6)	05/19/15	05/19/17
Coaxial Cable - Chamber 3 cable set	Micro-Coax	Chamber 3 cable set	KMKM-0244-00; KMKM-0670-00; KFKF-0198-00	12/05/15	12/05/17
Function Generator	Standford	DS340	25200	02/02/16	02/02/18
Terminator N 20W	Narda	8205	#14		
Tuneable Notch Filter 250-850 MHz	Eagle	TNF-200	250-850 MHz (#19)	06/26/15	06/26/17
DC Power Supply	HP	6286A	1744A03842	NA	NA

### EMI RECEIVER SOFTWARE VERSION

The receiver firmware used was version 4.43 Service Pack 3

END OF TEST REPORT