

---

# FCC Part 95 Rules Test Report

---

Report No.: AGC03590180701FE10

**FCC ID** : MMAGXT1050G  
**PRODUCT NAME** : Two way radio  
**BRAND NAME** : MIDLAND  
**MODEL NAME** : GXT1000G, GXT1000, GXT1050  
**CLIENT** : Midland Radio Corporation  
**DATE OF ISSUE** : Sep. 19, 2018  
**STANDARD(S)** : FCC Part 95 Rules  
**REPORT VERSION** : V 1.4

Attestation of *Global Compliance (Shenzhen) Co., Ltd*

**CAUTION:**

This report shall not be reproduced except in full without the written permission of the test laboratory and shall not be quoted out of context.



**Report Revise Record**

<b>Report Version</b>	<b>Revise Time</b>	<b>Issued Date</b>	<b>Valid Version</b>	<b>Notes</b>
V1.0	/	Jul. 17, 2018	Invalid	Initial Release
V1.1	1 <sup>st</sup>	Sep. 06, 2018	Invalid	Revise Report
V1.2	2 <sup>nd</sup>	Sep. 10, 2018	Invalid	Revise Report P17-18 P37-38
V1.3	3 <sup>rd</sup>	Sep. 13, 2018	Invalid	Revise Report
V1.4	4 <sup>th</sup>	Sep. 19, 2018	Valid	Revise Report

**VERIFICATION OF COMPLIANCE**

<b>Applicant:</b>	MIDLANDRadio Corporation
	5900 Parretta Drive Kansas City, Missouri United States 64120-2134
<b>Manufacturer:</b>	MIDLANDRadio Corporation
	5900 Parretta Drive Kansas City, Missouri United States 64120-2134
<b>Product Designation:</b>	Two way radio
<b>Brand Name:</b>	MIDLAND
<b>Test Model</b>	GXT1000G
<b>Series Model</b>	GXT1000, GXT1050
<b>Declaration of Difference</b>	All the same except for the model name and appearance color.
<b>Date of Test:</b>	Jul. 10, 2018 to Jul, 17,2018

**WE HEREBY CERTIFY THAT:**

The above equipment was tested by Attestation of Global Compliance (Shenzhen) Co., Ltd. The data evaluation, test procedures, and equipment configurations shown in this report were made in accordance with the procedures given in ANSI/TIA- 603-E(2016). The sample tested as described in this report is in compliance with the FCC Rules Part 95 requirements

The test results of this report relate only to the tested sample identified in this report.

Tested by

*Steven Zhou*

Steven Zhou(Zhou Pengyun) Jul. 17, 2018

Reviewed by

*Bart Xie*

Bart Xie(Xie Xiaobin) Sep. 19, 2018

Approved by

*Forrest Lei*

Forrest Lei(Lei Yonggang)  
Authorized Officer Sep. 19, 2018

**TABLE OF CONTENTS**

**1. GENERAL INFORMATION ..... 6**

1.1 PRODUCT DESCRIPTION ..... 6

1.2 RELATED SUBMITTAL(S) / GRANT (S)..... 8

1.3 TEST METHODOLOGY..... 8

1.4 TEST FACILITY ..... 8

1.5 SPECIAL ACCESSORIES..... 8

1.6 EQUIPMENT MODIFICATIONS..... 8

**2. SYSTEM TEST CONFIGURATION ..... 9**

2.1 EUT CONFIGURATION ..... 9

2.2 EUT EXERCISE ..... 9

2.4 CONFIGURATION OF TESTED SYSTEM..... 10

**3. SUMMARY OF TEST RESULTS ..... 10**

**4. DESCRIPTION OF TEST MODES ..... 12**

**5. FREQUENCY TOLERANCE ..... 13**

5.1 PROVISIONS APPLICABLE ..... 13

5.2 MEASUREMENT PROCEDURE ..... 13

5.3 TEST SETUP BLOCK DIAGRAM ..... 14

5.4 TEST RESULT..... 15

**6. EMISSION BANDWIDTH ..... 15**

6.1 PROVISIONS APPLICABLE ..... 17

6.2 MEASUREMENT PROCEDURE ..... 18

6.3 TEST SETUP BLOCK DIAGRAM ..... 18

6.4 MEASUREMENT RESULT..... 19

**7. UNWANTED RADIATION..... 21**

7.1 PROVISIONS APPLICABLE ..... 21

7.2 MEASUREMENT PROCEDURE ..... 21

7.3 TEST SETUP BLOCK DIAGRAM ..... 22

7.4 MEASUREMENT RESULTS: ..... 22

7.5 EMISSION MASK PLOT ..... 25

**8. MAXIMUM TRANSMITTER POWER ..... 27**

8.1 PROVISIONS APPLICABLE ..... 30

8.2 TEST PROCEDURE..... 30

8.3 TEST CONFIGURATION..... 30

8.4 TEST RESULT..... 31

<b>9. MODULATION CHARACTERISTICS .....</b>	<b>33</b>
9.1 PROVISIONS APPLICABLE .....	33
9.2 MEASUREMENT METHOD .....	33
9.3 MEASUREMENT RESULT .....	33
<b>APPENDIX I: PHOTOGRAPHS OF SETUP .....</b>	<b>37</b>
<b>APPENDIX II: EXTERNAL VIEW OF EUT .....</b>	<b>37</b>

## 1. GENERAL INFORMATION

### 1.1 PRODUCT DESCRIPTION

The EUT is a GMRS Radio designed for voice communication. It is designed by way of utilizing the FM modulation achieves the system operating.

A major technical description of EUT is described as following:

Hardware Version	GXT1000G_X5
Software Version	V112
Modulation	FM
Channel Separation	25KHz/12.5KHz
Emission Type	F3E
Emission Bandwidth	10.53KHz(25KHz) 10.51KHz(12.5KHz)
Maximum Transmitter Power	26.58dBm(0.46W) 33.98dBm(2.5W)
Rated Output power	0.5W/2.85W (It was fixed by the manufacturer, any individual can't arbitrarily change it.)
Antenna Designation	Inseparable
Antenna Gain	1.5dBi
Power Supply	DC 6V, 700mAh (by battery)
Limiting Voltage	DC 5.1 V-6.9 V
Operation Frequency Range and Channel	GMRS: 462.5625MHz -462.7125(2.85W) 467.5625MHz -467.7125MHz(0.5W) 462.550MHz -462.7250MHz(2.85W) Test Channel :4, 11 and 19 channel
Frequency Tolerance	1.042ppm

**Channel List:**

CH. No	CH. Freq	Power	CH. No	CH. Freq	Power
1	462.5625	2.85W	12	467.6625	0.5W
2	462.5875		13	467.6875	
3	462.6125		14	467.7125	
4	462.6375		15	462.550	2.85W
5	462.6625		16	462.575	
6	462.6875		17	462.600	
7	462.7125		18	462.625	
8	467.5675	19	462.650		
9	467.5875	20	462.675		
10	467.6125	21	462.700		
11	467.6375	0.5W	22	462.725	

## 1.2 RELATED SUBMITTAL(S) / GRANT (S)

This submittal(s) (test report) is intended for FCC ID: MMAGXT1050G, filing to comply with the FCC Part 95 requirements.

## 1.3 TEST METHODOLOGY.

The radiated emission testing was performed according to the procedures of ANSI/TIA-603-E (2016) .

## 1.4 TEST FACILITY

<b>Test Site</b>	Attestation of Global Compliance (Shenzhen) Co., Ltd
<b>Location</b>	1-2F., Bldg.2, No.1-4, Chaxi Sanwei Technical Industrial Park, Gushu, Xixiang, Bao'an District B112-B113, Bldg.12, Baoan Bldg Materials Center, No.1 of Xixiang Inner Ring Road, Baoan District, Shenzhen 518012
<b>NVLAP LAB CODE</b>	600153-0
<b>Designation Number</b>	CN5028
<b>FCC Test Firm Registration Number</b>	682566
<b>Description</b>	Attestation of Global Compliance(Shenzhen) Co., Ltd is accredited by National Voluntary Laboratory Accreditation program, NVLAP Code 600153-0

## 1.5 SPECIAL ACCESSORIES

Not available for this EUT intended for grant.

## 1.6 EQUIPMENT MODIFICATIONS

Not available for this EUT intended for grant.



## **2. SYSTEM TEST CONFIGURATION**

### **2.1 EUT CONFIGURATION**

The EUT configuration for testing is installed on RF field strength measurement to meet the Commission's requirement and operating in a manner which intends to maximize its emission characteristics in a continuous normal application.

### **2.2 EUT EXERCISE**

The Transmitter was operated in the normal operating mode. The TX frequency was fixed which was for the purpose of the measurements.

**2.4 CONFIGURATION OF TESTED SYSTEM**

Fig. 2-1 Configuration of Tested System



Table 2-1 Equipment Used in Tested System

Item	Equipment	Model No.	Identifier	Note
1	Two way radio	GXT1000	FCC ID: MMAGXT1050G	EUT

**3. SUMMARY OF TEST RESULTS**

FCC Rules	Description Of Test	Result
§ 95.1767	Maximum Transmitter Power	Compliant
§ FCC part 2.1047 § 95.1775	Modulation Characteristics	Compliant
§ FCC part 2.1049 § 95.1773 § 95.1779	Occupied Bandwidth and Emission Mask	Compliant
§ FCC Part 2.1055(d) § 95.1765	Frequency Stability	Compliant
§ 95.1779	Transmitter Radiated Spurious Emission	Compliant

**LIST OF EQUIPMENTS USED**

Equipment	Manufacturer	Model	S/N	Cal. Date	Cal. Due
TEST RECEIVER	R&S	ESCI	10096	Jun. 12, 2018	Jun. 11, 2019
EXA Signal Analyzer	Aglient	N9010A	MY53470504	Dec.08, 2017	Dec.07, 2018
Horn antenna	SCHWARZBECK	BBHA 9170	#768	Sep.20, 2017	Sep.19, 2018
preamplifier	ChengYi	EMC184045SE	980508	Sep.15, 2017	Sep.14, 2018
Double-Ridged Waveguide Horn	ETS LINDGREN	3117	00034609	May 18, 2017	May 17, 2019
Broadband Preamplifier	SCHWARZBECK	BBV 9718	9718-205	Jun. 12, 2018	Jun. 11, 2019
HORN ANTENNA	EM	EM-AH-10180	/	Mar.01, 2018	Feb.29, 2020
ANTENNA	SCHWARZBECK	VULB9168	VULB9168-494	Mar.01, 2018	Feb.29, 2020
ANTENNA	SCHWARZBECK	VULB9168	D69250	Sep.28, 2017	Sep.27, 2018
Small environmental tester	ESPEC	SH-242	--	Mar.02, 2018	Mar. 01, 2019
RF Communication Test Set	HP	HP8920B	--	Jun. 12, 2018	Jun. 11, 2019
Loop Antenna	A.H.Systems,Inc	SAS-562B	--	Mar. 01, 2018	Feb. 28, 2019
Attenuator	Weinschei Corp	58-30-33	731781	June 12, 2018	June 11, 2019
DC POWER	/	GPR-6060D	/	Mar. 01, 2018	Feb. 28, 2019
Signal Generator	AGILENT	E8257D	MY45141029	Sep. 21, 2017	Sep. 20, 2018

Note: 8920B can generate audio modulation frequency.

#### 4. DESCRIPTION OF TEST MODES

##### RF TEST MODES

The EUT (Two way radio) has been tested under normal operating condition. (GMRS TX) are chosen for testing at each channel separation.

No.	TEST MODES	CHANNEL SEPARATION
1	GMRS TX	12.5 KHz
2	GMRS TX	25 KHz

**Note:** Only the result of the worst case was recorded in the report.

## 5. FREQUENCY TOLERANCE

### 5.1 PROVISIONS APPLICABLE

Standard Applicable [Part 95.1765]The carrier frequency stability is the ability of the transmitter to maintain an assigned carrier frequency.

FCC Part 95.1765,

GMRS: The carrier frequency tolerance shall be better than  $\pm 2.5$  ppm for an occupied bandwidth of 12.5 kHz or less.

### 5.2 MEASUREMENT PROCEDURE

#### 5.2.1 Frequency stability versus environmental temperature

1. Setup the configuration per figure 1 for frequencies measurement inside an environment chamber, Install new battery in the EUT.
2. Turn on EUT and set SA center frequency to the EUT radiated frequency. Set SA Resolution Bandwidth to 1KHz and Video Resolution Bandwidth to 1KHz and Frequency Span to 50KHz.Record this frequency as reference frequency.
3. Set the temperature of chamber to 50°C. Allow sufficient time (approximately 30 min) for the temperature of the chamber to stabilize. While maintaining a constant temperature inside the chamber, turn the EUT on and measure the EUT operating frequency.
4. Repeat step 2 with a 10°C decreased per stage until the lowest temperature -30°C is measured, record all measured frequencies on each temperature step.

#### 5.2.2 Frequency stability versus input voltage

1. Setup the configuration per figure 1 for frequencies measured at temperature if it is within 15°C to 25°C. Otherwise, an environment chamber set for a temperature of 20°C shall be used. The EUT shall be powered by DC 6V.
2. Set SA center frequency to the EUT radiated frequency. Set SA Resolution Bandwidth to 1 KHz and Video Resolution Bandwidth to 1KHz. Record this frequency as reference frequency.
3. Supply the EUT primary voltage at the operating end point which is specified by manufacturer and record the frequency.

### 5.3 TEST SETUP BLOCK DIAGRAM

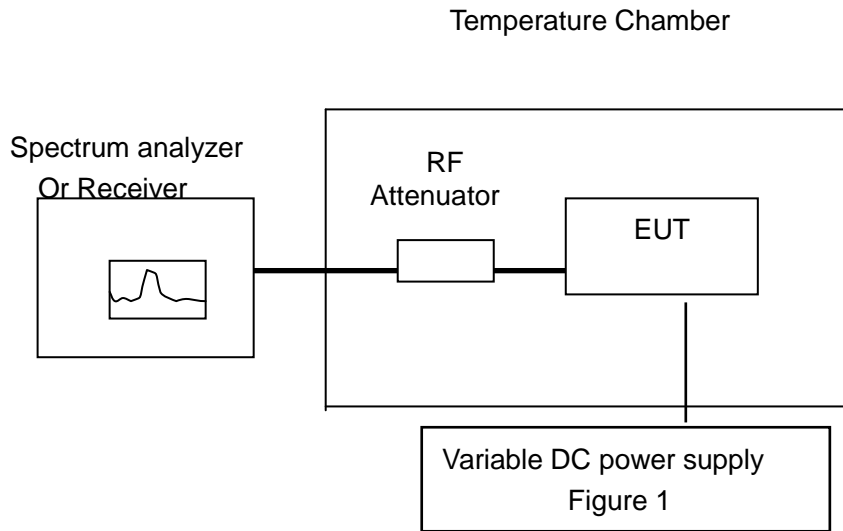

**5.4 TEST RESULT**

(1) Frequency stability versus input voltage (Supply nominal voltage is 6.0V)

Environment Temperature(°C)	Power (V)	Reference Frequency			Limit: ppm
		462.6375MHz	462.6500MHz	467.6375MHz	
50	DC 6.0V	0.653	0.562	0.798	±2.5for GMRS
40	DC 6.0V	0.870	0.496	0.943	
30	DC 6.0V	0.543	0.900	0.838	
20	DC 6.0V	1.076	0.955	0.781	
10	DC 6.0V	0.663	0.642	0.609	
0	DC 6.0V	1.048	0.316	0.809	
-10	DC 6.0V	0.506	0.999	0.937	
-20	DC 6.0V	0.993	0.317	1.076	
-30	DC 6.0V	0.829	0.540	0.621	
Result	Pass				

(2) Frequency stability versus input voltage (Battery limiting voltage is 5.1V)

Environment Temperature(°C)	Power (V)	Reference Frequency			Limit: ppm
		462.6375MHz	462.6500MHz	467.6375MHz	
50	DC 5.1V	0.413	0.761	0.512	±2.5for GMRS
40	DC 5.1V	0.833	0.380	0.638	
30	DC 5.1V	0.954	0.385	0.768	
20	DC 5.1V	0.531	0.798	0.895	
10	DC 5.1V	0.988	0.513	0.802	
0	DC 5.1V	0.972	0.859	0.601	
-10	DC 5.1V	0.569	0.588	0.843	
-20	DC 5.1V	0.665	0.717	0.879	
-30	DC 5.1V	0.778	0.639	0.955	
Result	Pass				

(3) Frequency stability versus input voltage (Battery Fully Charged voltage is 6.9V)

Environment Temperature(°C)	Power (V)	Reference Frequency			Limit: ppm
		462.6375MHz	462.6500MHz	467.6375MHz	
50	DC 6.9V	0.951	0.619	0.837	±2.5for GMRS
40	DC 6.9V	0.598	0.324	0.652	
30	DC 6.9V	0.875	0.422	0.522	
20	DC 6.9V	0.954	0.869	0.632	
10	DC 6.9V	0.765	0.972	0.430	
0	DC 6.9V	0.747	0.399	0.918	
-10	DC 6.9V	0.710	0.842	0.491	
-20	DC 6.9V	0.461	0.629	0.635	
-30	DC 6.9V	0.873	0.393	0.594	
Result	Pass				

(4) Frequency stability versus input voltage (Battery end point voltage is 4.75V)

Environment Temperature(°C)	Power (V)	Reference Frequency			Limit: ppm
		462.6375MHz	462.6500MHz	467.6375MHz	
50	DC 4.75V	0.343	0.326	0.652	±2.5for GMRS
40	DC 4.75V	0.698	0.620	0.701	
30	DC 4.75V	0.942	0.675	0.360	
20	DC 4.75V	0.561	0.303	0.815	
10	DC 4.75V	0.397	0.603	0.377	
0	DC 4.75V	0.514	0.913	0.481	
-10	DC 4.75V	0.877	0.918	0.878	
-20	DC 4.75V	0.379	0.971	0.621	
-30	DC 4.75V	0.923	0.966	0.420	
Result	Pass				

Note: The unit of frequency stability is ppm.



## 6. EMISSION BANDWIDTH

### 6.1 PROVISIONS APPLICABLE

FCC Part 95.1773: GMRS:

(a) Main channels. The authorized bandwidth is 20 kHz for GMRS transmitters operating on any of the 462 MHz main channels, or any of the 467 MHz main channels.

(b) Interstitial channels. The authorized bandwidth is 20 kHz for GMRS transmitters operating on any of the 462 MHz interstitial channels, and is 12.5 kHz for GMRS transmitters operating on any of the 467 MHz interstitial channels.

Occupied Bandwidth: The EUT was connected to the audio signal generator and the spectrum analyzer via the main RF connector, and through an appropriate attenuator. The EUT was controlled to transmit its maximum power. Then the bandwidth of 99% power can be measured by the spectrum analyzer.

#### **Emission Masks**

(b) Attenuation requirements. The power of unwanted emissions must be attenuated below the transmitter output power in Watts (P) by at least:

(1) 25 dB (decibels) on any frequency removed from the center of the authorized bandwidth by more than 50% up to and including 100% of the authorized bandwidth.

(2) 35 dB on any frequency removed from the center of the authorized bandwidth by more than 100% up to and including 250% of the authorized bandwidth.

(3)  $83 \log (f_d \div 5)$  dB on any frequency removed from the center of the authorized bandwidth by a displacement frequency ( $f_d$  in kHz) of more than 5 kHz up to and including 10 kHz.

(4)  $116 \log (f_d \div 6.1)$  dB or  $50 + 10 \log (P)$  dB, whichever is the lesser attenuation, on any frequency removed from the center of the authorized bandwidth by a displacement frequency ( $f_d$  in kHz), of more than 10 kHz up to and including 250% of the authorized bandwidth.

(5) 25 dB on any frequency removed from the center of the authorized bandwidth by more than 50% up to and including 150% of the authorized bandwidth.

(6) 35 dB on any frequency removed from the center of the authorized bandwidth by more than 150% up to and including 250% of the authorized bandwidth.

(7)  $43 + 10 \log (P)$  dB on any frequency removed from the center of the authorized bandwidth by more than 250%.

## 6.2 MEASUREMENT PROCEDURE

- 1). The EUT was modulated by 2.5 KHz Sine wave audio signal, The level of the audio signal employed is 16 dB greater than that necessary to produce 50% of rated system deviation. Rated system deviation is 2.5 kHz (12.5 kHz channel spacing).
- 2). Set SPA Center Frequency = fundamental frequency, RBW=300Hz.VBW= 1kHz, Span =30 KHz.
- 3). Set SPA Max hold. Mark peak, -26 dB.

## 6.3 TEST SETUP BLOCK DIAGRAM

Below1GHz

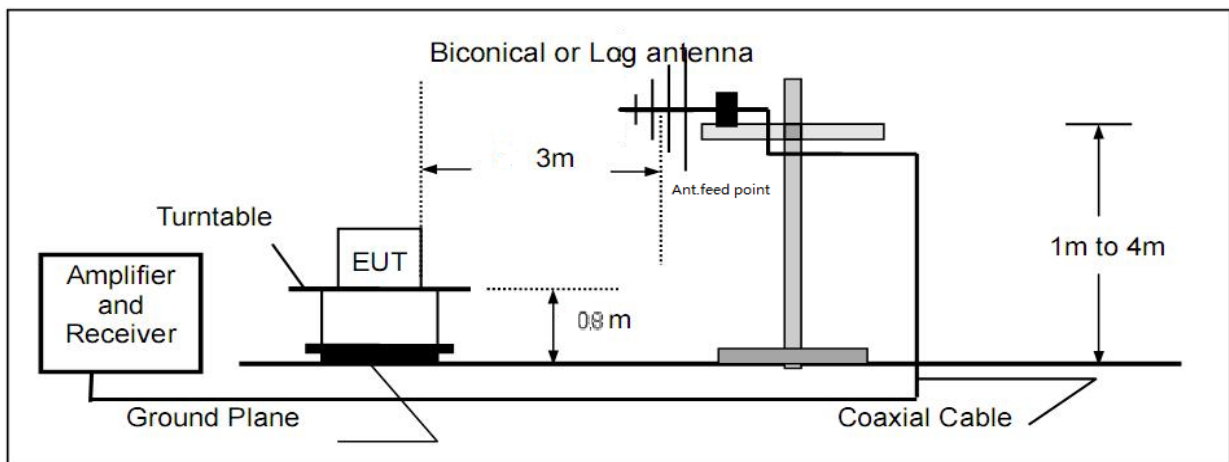

6.4 MEASUREMENT RESULT

26 dB Bandwidth Measurement Result			
Operating Frequency	12.5 KHz Channel Separation		
	Test Data	Limits	Result
462.6375MHz	10.45KHz	20.0 KHz	Pass
462.6500MHz	10.53KHz	20.0 KHz	Pass
467.6375MHz	10.51KHz	12.5 KHz	Pass

Occupied bandwidth of 462.6375MHz

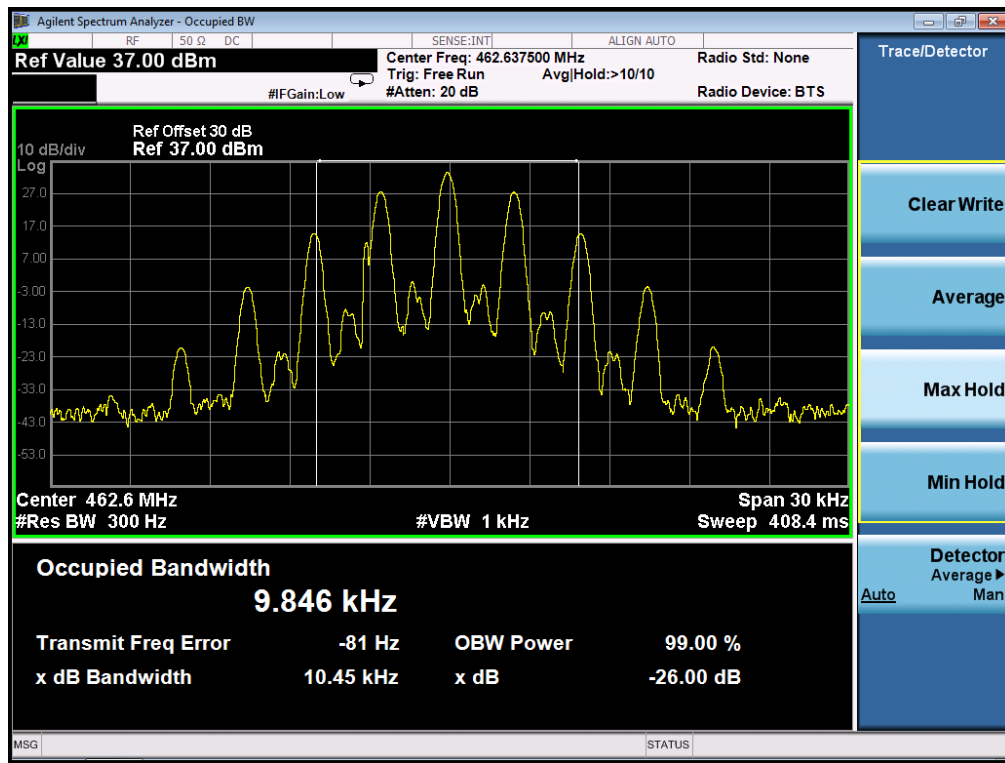

**Occupied bandwidth of 462.6500MHz**

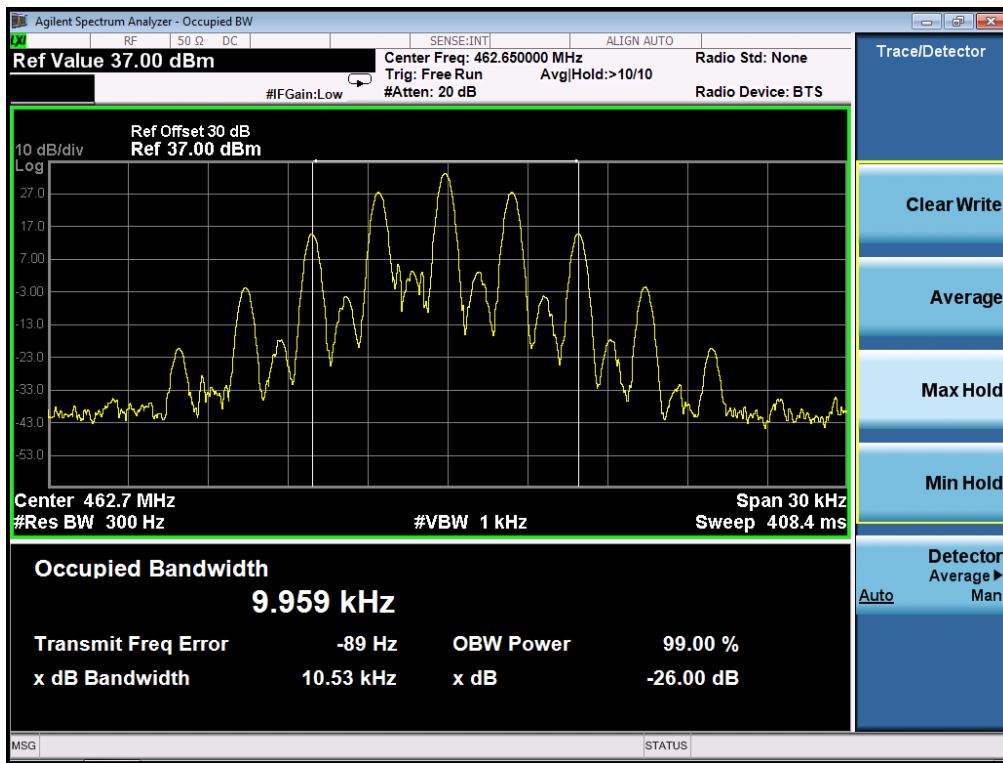

**Occupied bandwidth of 467.6375MHz**

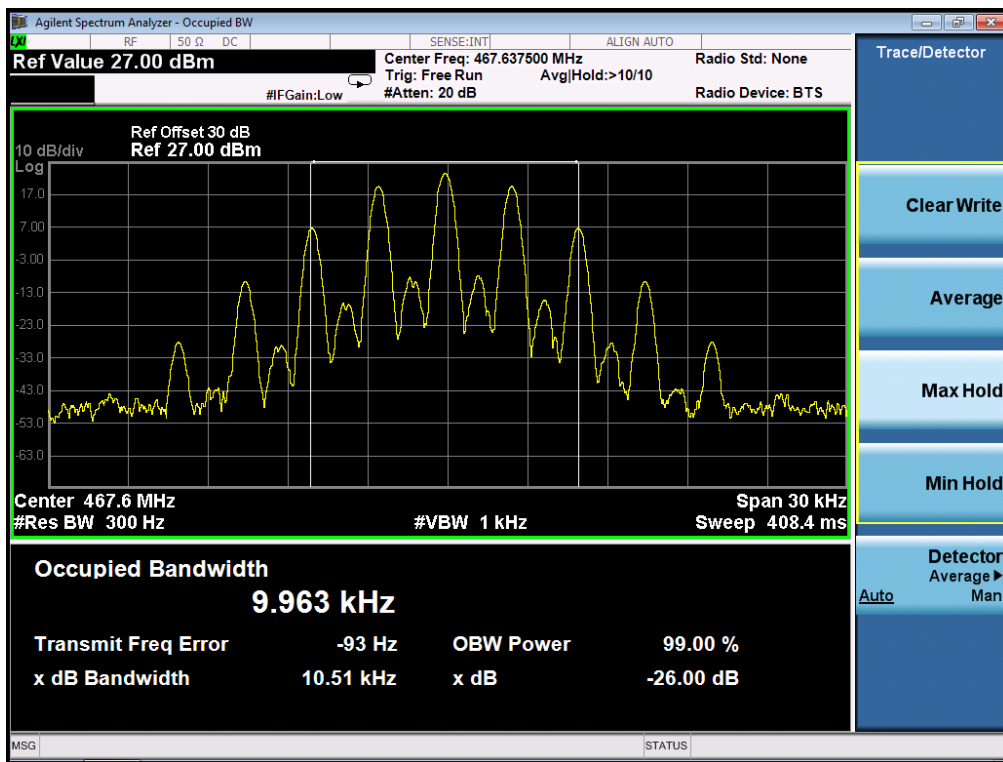

## 7. UNWANTED RADIATION

### 7.1 PROVISIONS APPLICABLE

Standard Applicable [FCC Part 95.1779]

According to FCC section 95.1779, At least  $43 + 10 \log_{10}(T)$  dB on any frequency removed from the center of the authorized bandwidth by more than 250%.

### 7.2 MEASUREMENT PROCEDURE

Each GMRS transmitter type must be designed to comply with the applicable unwanted emissions limits in this section.

(a) Emission masks. Emission masks applicable to transmitting equipment in the GMRS are defined by the requirements in the following table. The numbers in the attenuation requirements column refer to rule paragraph numbers under paragraph (b) of this section.

Emission types filter	Attenuation requirements
A1D, A3E, F1D, G1D, F2D, F3E, G3E with audio filter	(1), (2), (7)
A1D, A3E, F1D, G1D, F3E, G3E without audio filter	(3), (4), (7)
H1D, J1D, R1D, H3E, J3E, R2E	(5), (6), (7)

(1) Filtering noted for GMRS transmitters refers to the requirement in §95.1775(e).

(2) Unwanted emission power may be measured as either mean power or peak envelope power, provided that the transmitter output power is measured the same way.

(b) Attenuation requirements. The power of unwanted emissions must be attenuated below the transmitter output power in Watts (P) by at least:

(1) 25 dB (decibels) on any frequency removed from the center of the authorized bandwidth by more than 50% up to and including 100% of the authorized bandwidth.

(1) Filtering noted for GMRS transmitters refers to the requirement in §95.1775(e).

(2) Unwanted emission power may be measured as either mean power or peak envelope power, provided that the transmitter output power is measured the same way.

(b) Attenuation requirements. The power of unwanted emissions must be attenuated below the transmitter output power in Watts (P) by at least:

(1) 25 dB (decibels) on any frequency removed from the center of the authorized bandwidth by more than 50% up to and including 100% of the authorized bandwidth.

1) The spectrum setting for scanning Radiated Emission below 1 GHz is RBW = 100 kHz, VBW = 300 kHz and above 1 GHz is RBW = 1 MHz, VBW = 3 MHz. Detector mode is positive peak.

2) In the semi-anechoic chamber, setup as illustrated above the EUT placed on the 0.8m height (for frequencies < 1GHz) or 1.5m (for frequencies > 1GHz) of Turn Table, rotated the table around 360 degrees to search the maximum radiation power and receiver antenna shall be rotated vertical and horizontal polarization and moved height from 1m to 4m to find the maximum polar radiated power. The "Read Value" is the spectrum reading the maximum power value.

3) The substitution antenna is substituted for EUT at the same position and signals generator (S.G) export the CW signal to the substitution antenna via a TX cable. The receiver antenna shall be rotated vertical and horizontal polarization and moved height from 1m to 4m to find the maximum radiation power. Record the power level of maximum radiation power from spectrum. So, the measured substitution value = Ref level of S.G + TX cables loss – Substituted Antenna Gain.

4) Final Radiated Spurious Emission = “Read Value” + Measured substitution value.

**7.3 TEST SETUP BLOCK DIAGRAM**

**TEST SETUP**

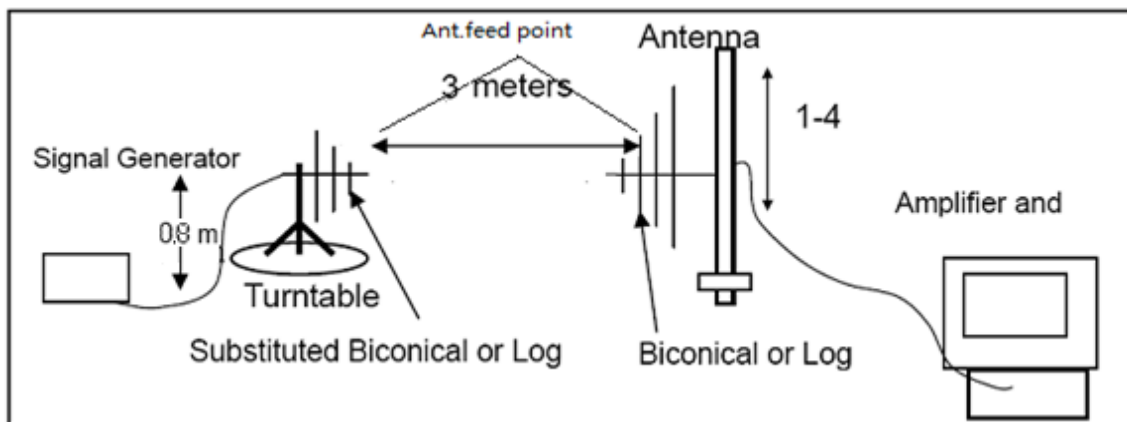
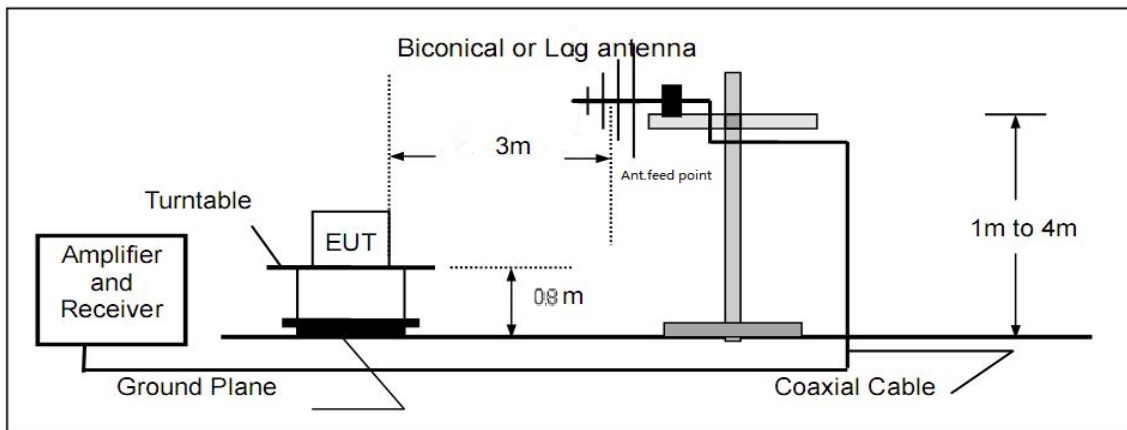

**7.4 MEASUREMENT RESULTS:**

the unwanted emission should be attenuated below TP by at least  $43+10 \log(\text{Transmit Power})$  dB

**Limit: At least  $43+10 \log (P) =43+10\log (0.5) =40$  (dBc) 27-40=-13dBm**

**At least  $43+10 \log (P) =43+10\log (2.85) =34.5$  (dBc) 34.5-47.5=-13dBm**

**NOTE:** In the actual test, with the Walkie-talkie headphones.

**Measurement Result for 12.5 KHz Channel Separation @ 462.6375MHz**

Emission Frequency (MHz)	Ant. Polarity(H/V)	Measurement Result (dBm)	Limit (dBm)	Result(P/F)
462.638	H	0		pass
925.275	H	-48.5	-13	pass
1387.91	H	-42.1	-13	pass
1850.550	H	-40.9	-13	pass
2313.188	H	-39.1	-13	pass
2775.825	H	-41.6	-13	pass
3238.463	H	-53.7	-13	pass
3701.100	H	-45.9	-13	pass
4163.738	H	-43.3	-13	pass
4626.375	H	-47.3	-13	pass

Emission Frequency (MHz)	Ant. Polarity(H/H)	Measurement Result (dBm)	Limit (dBm)	Result(P/F)
462.638	V	0		pass
925.275	V	-48.9	-13	pass
1387.91	V	-56.1	-13	pass
1850.550	V	-44.3	-13	pass
2313.188	V	-40.5	-13	pass
2775.825	V	-41.4	-13	pass
3238.463	V	-50.8	-13	pass
3701.100	V	-50.6	-13	pass
4163.738	V	-46.7	-13	pass
4626.375	V	-51.8	-13	pass

**Measurement Result for 12.5 KHz Channel Separation @ 462.6500MHz**

Emission Frequency (MHz)	Ant. Polarity(H/V)	Measurement Result (dBm)	Limit (dBm)	Result(P/F)
462.638	H	0		pass
925.275	H	-47.1	-13	pass
1387.91	H	-43.6	-13	pass
1850.550	H	-40.7	-13	pass
2313.188	H	-38.5	-13	pass
2775.825	H	-48.9	-13	pass
3238.463	H	-51.1	-13	pass
3701.100	H	-43.7	-13	pass
4163.738	H	-47.3	-13	pass
4626.375	H	-44.3	-13	pass

Emission Frequency (MHz)	Ant. Polarity(H/H)	Measurement Result (dBm)	Limit (dBm)	Result(P/F)
462.638	V	0		pass
925.275	V	-56.1	-13	pass
1387.91	V	-51.9	-13	pass
1850.550	V	-47.4	-13	pass
2313.188	V	-49.2	-13	pass
2775.825	V	-41.4	-13	pass
3238.463	V	-45.3	-13	pass
3701.100	V	-53.7	-13	pass
4163.738	V	-41.1	-13	pass
4626.375	V	-53.8	-13	pass

**Measurement Result for 12.5 KHz Channel Separation @ 467.6375MHz**

Emission Frequency (MHz)	Ant. Polarity(H/V)	Measurement Result (dBm)	Limit (dBm)	Result(P/F)
467.638	H	0		pass
935.275	H	-51.7	-13	pass
1402.913	H	-49.1	-13	pass
1870.550	H	-40.6	-13	pass
2338.188	H	-46.1	-13	pass
2805.825	H	-47.8	-13	pass
3273.463	H	-53.6	-13	pass
3741.100	H	-51.9	-13	pass
4208.738	H	-43.4	-13	pass
4676.375	H	-48.7	-13	pass

Emission Frequency (MHz)	Ant. Polarity(H/V)	Measurement Result (dBm)	Limit (dBm)	Result(P/F)
467.638	V	0		pass
935.275	V	-53.4	-13	pass
1402.913	V	-45.1	-13	pass
1870.550	V	-41.9	-13	pass
2338.188	V	-52.3	-13	pass
2805.825	V	-50.7	-13	pass
3273.463	V	-47.1	-13	pass
3741.100	V	-50.9	-13	pass
4208.738	V	-41.6	-13	pass
4676.375	V	-45.1	-13	pass



### 7.5 EMISSION MASK PLOT

Standard Applicable [FCC Part 95.1779] GMRS: Unwanted emissions shall be attenuated below the unmodulated carrier power in accordance with the following:

- (1) At least 25 dB (decibels) on any frequency removed from the center of the authorized bandwidth by more than 50 % up to and including 100% of the authorized bandwidth.
- (2) At least 35 dB on any frequency removed from the center of the authorized bandwidth by more than 100 % up to and including 250 % of the authorized bandwidth.
- (3) At least  $43 + 10 \log_{10}(T)$  dB on any frequency removed from the center of the authorized bandwidth by more than 250 %.

The detailed procedure employed for Emission Mask measurements are specified as following:

- The transmitter shall be modulated by a 2.5 kHz audio signal,
- The level of the audio signal employed is 16 dB greater than that necessary to produce 50% of rated system deviation. Rated system deviation is 2.5 kHz.

**Channel 4:**

#### The Worst Emission Mask for channel 4

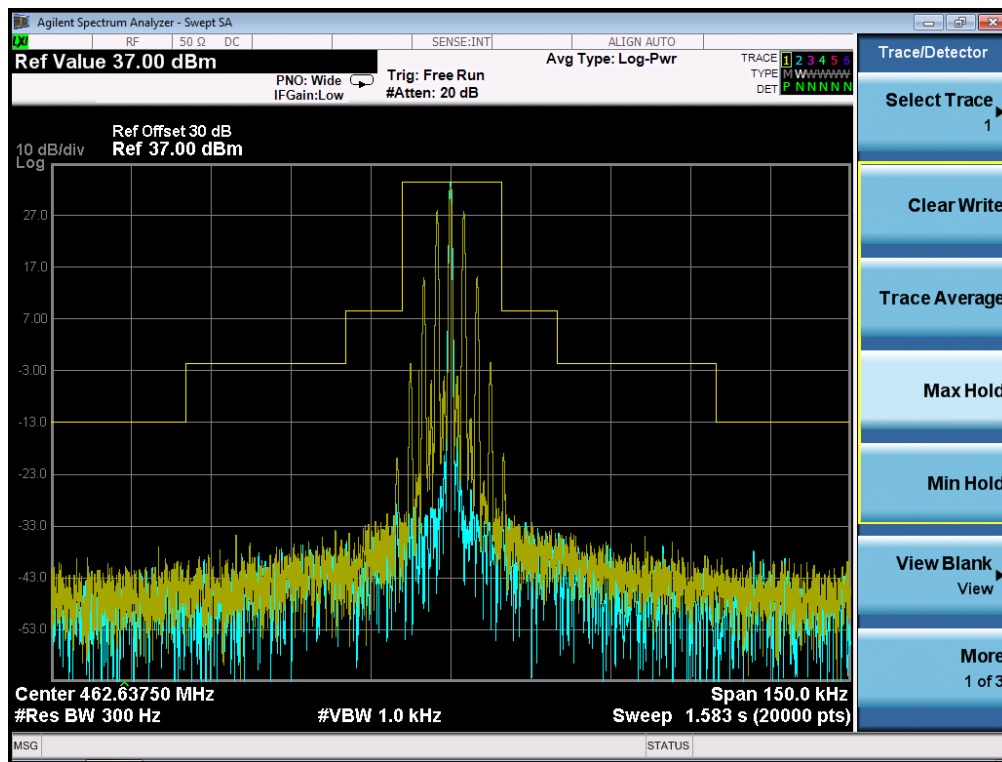

CHANNEL 11:

The Worst Emission Mask for channel 11

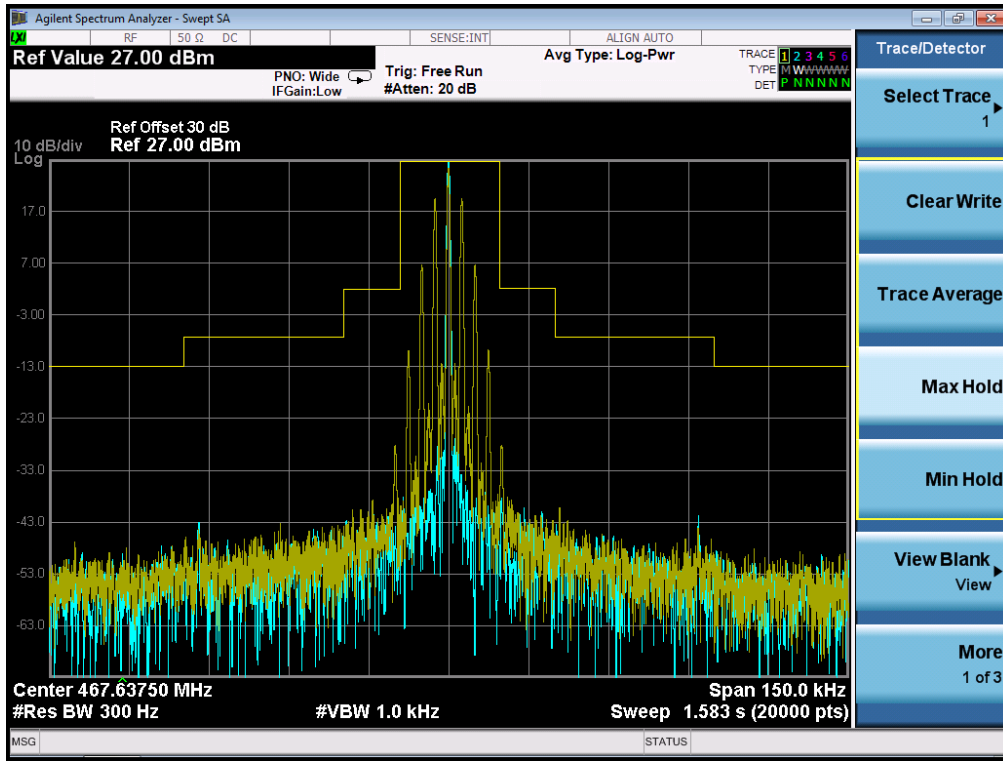

Channel 19:

The Worst Emission Mask for channel 19

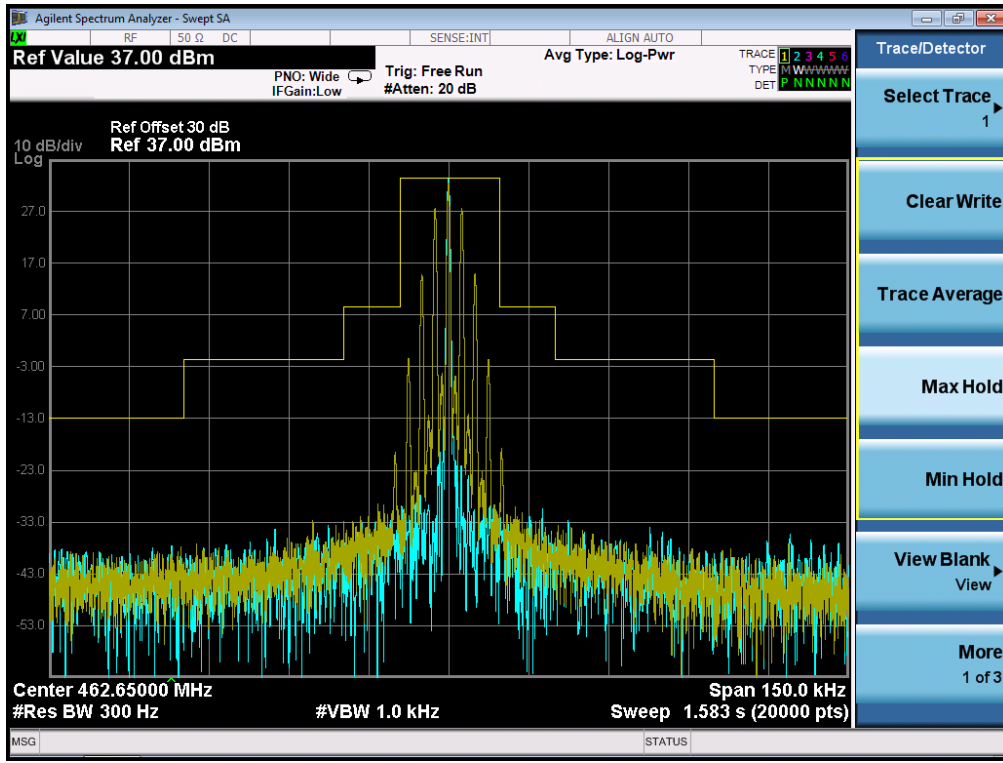

## 7.6. AUDIO LOW PASS FILTER

### 7.6.1. Test Setup

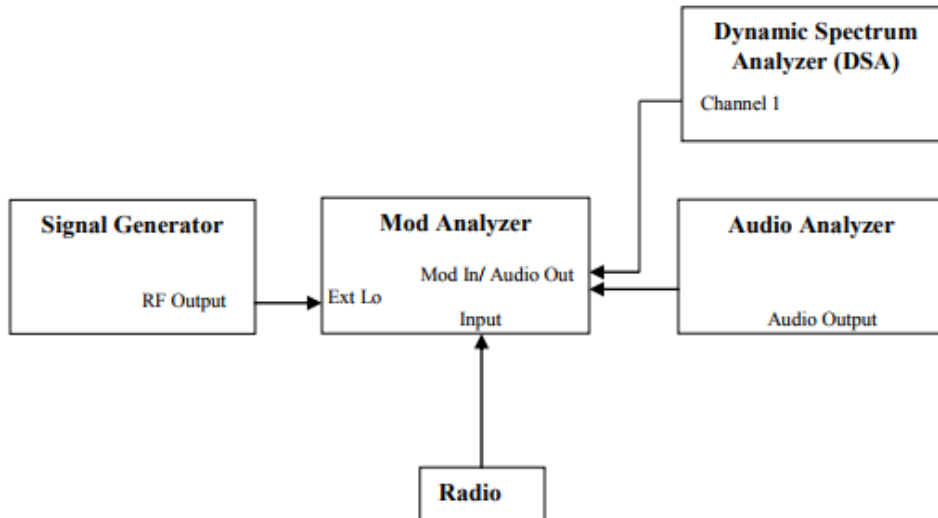

- 1) The DUT transmitter output port was connected to Modulation Analyzer.
- 2) Path loss for the measurement included.
- 3) Press 23.1SPCL on modulation analyzer to enable the external LO from Siggen.
- 4) Set the Siggen frequency to  $F_c + 1.5\text{MHz}$ , RF output level to 0dBm without modulation.
- 5) Transmit the radio and set the audio analyzer to 1 kHz audio frequency and 60% of the maximum deviation.
- 6) Up the amplitude by 20dB.
- 7) On DSA, get the reference point to 0dB.
- 8) Vary the frequency on audio analyzer from 3 kHz to 30 kHz, record the audio tone from DSA.

### 7.6.2. Test Limits:

#### §95.1775 GMRS modulation requirements

(e) Audio filter. Each GMRS transmitter type must include audio frequency low pass filtering, unless it complies with the applicable paragraphs of §95.1779 (without filtering).

(1) The filter must be between the modulation limiter and the modulated stage of the transmitter.

(2) At any frequency ( $f$  in kHz) between 3 and 20 kHz, the filter must have an attenuation of at least  $60 \log(f/3)$  dB more than the attenuation at 1 kHz. Above 20 kHz, it must have an attenuation of at least 50 dB more than the attenuation at 1 kHz.

7.6.3. Test Result

Audio Frequency (kHz)	Response Attenuation (dB)	Limit (dB)
1	0	/
3	-0.90	0.00
4	-15.50	-7.50
5	-23.31	-13.31
6	-28.06	-18.06
7	-32.08	-22.08
8	-35.56	-25.56
9	-38.63	-28.63
10	-41.37	-31.37
15	-51.94	-41.94
20	-60.00	-50.00
30	-60.50	-50.00
50	-60.70	-50.00
70	-61.00	-50.00

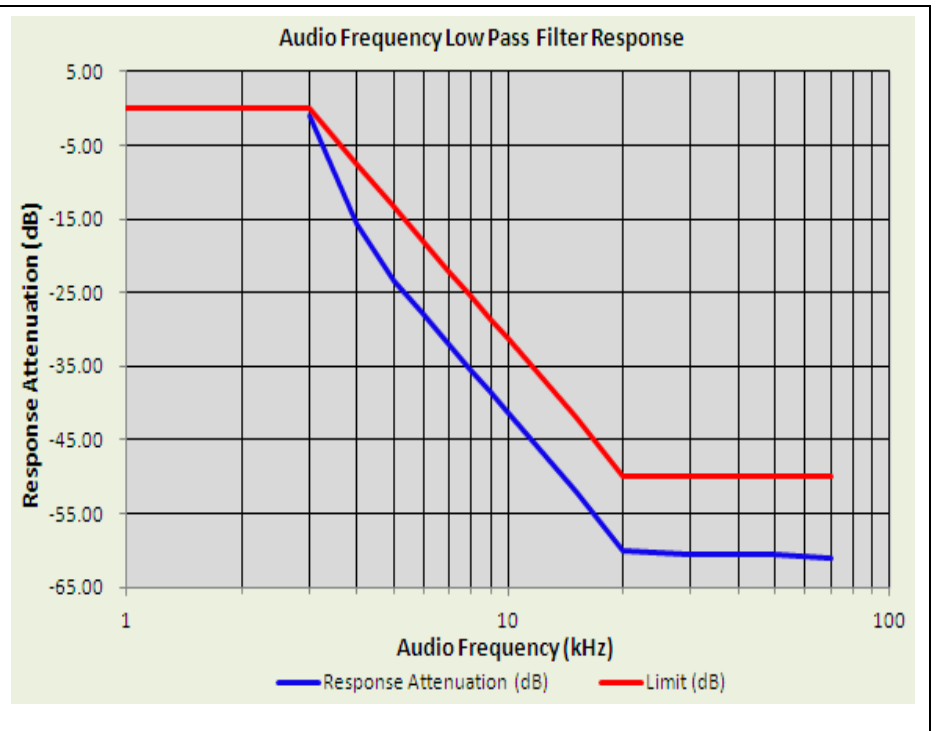

## **8. MAXIMUM TRANSMITTER POWER**

### **8.1 PROVISIONS APPLICABLE**

FCC Part 95.1767 For GMRS, the maximum permissible transmitter output power effective radiated power (e.r.p.) as follows.

This section contains transmitting power limits for GMRS stations. The maximum transmitting power depends on which channels are being used and the type of station.

(a) 462/467 MHz main channels. The limits in this paragraph apply to stations transmitting on any of the 462 MHz main channels or any of the 467 MHz main channels. Each GMRS transmitter type must be capable of operating within the allowable power range. GMRS licensees are responsible for ensuring that their GMRS stations operate in compliance with these limits.

(1) The transmitter output power of mobile, repeater and base stations must not exceed 50 Watts.

(2) The transmitter output power of fixed stations must not exceed 15 Watts.

(b) 462 MHz interstitial channels. The effective radiated power (ERP) of mobile, hand-held portable and base stations transmitting on the 462 MHz interstitial channels must not exceed 5 Watts.

(c) 467 MHz interstitial channels. The effective radiated power (ERP) of hand-held portable units transmitting on the 467 MHz interstitial channels must not exceed 0.5 Watt. Each GMRS transmitter type capable of transmitting on these channels must be designed such that the ERP does not exceed 0.5 Watt.

### **8.2 TEST PROCEDURE**

1) The spectrum setting for Equivalent Isotropically Radiated Power (EIRP) is RBW = 100 kHz, VBW = 300 kHz. Detector Mode is RMS.

2) In the semi-anechoic chamber, setup as illustrated above the EUT placed on the 0.8m height of Turn Table, rotated the table 45 degree each interval to search the maximum radiation power and receiver antenna shall be rotated vertical and horizontal polarization and moved height from 1m to 4m to find the maximum polar radiated power for each degree interval. The "Read Value" is the spectrum reading of maximum power value.

3) The substitution antenna is substituted for EUT at the same position and signals generator (S.G) export the CW signal to the substitution antenna via a TX cable. The receiver antenna shall be rotated vertical and horizontal polarization and moved height from 1m to 4m to find the maximum radiation power. Record the power level of maximum radiation power from spectrum. So, the Measured substitution value = Ref level of S.G + TX cables loss – Substituted Antenna Gain.

### **8.3 TEST CONFIGURATION**

**Effective Radiated Power**

**Radiated Below 1GHz**

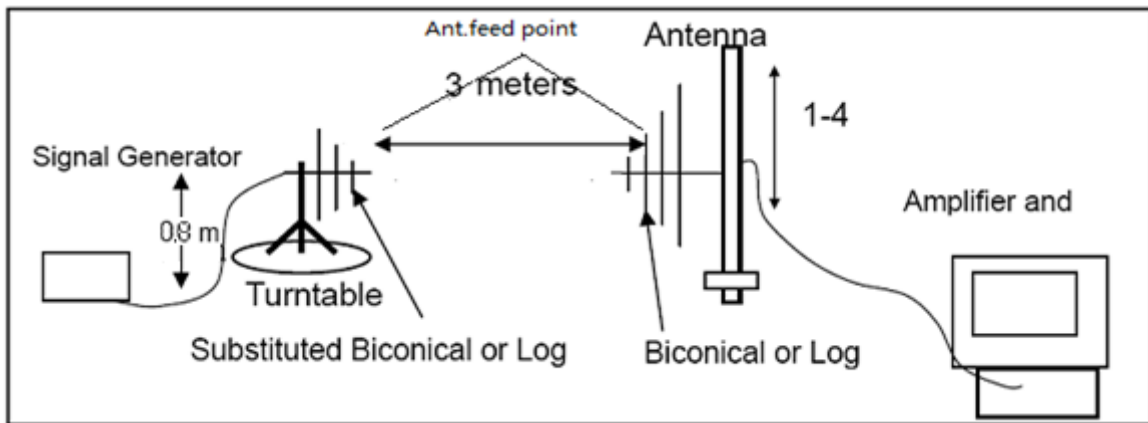
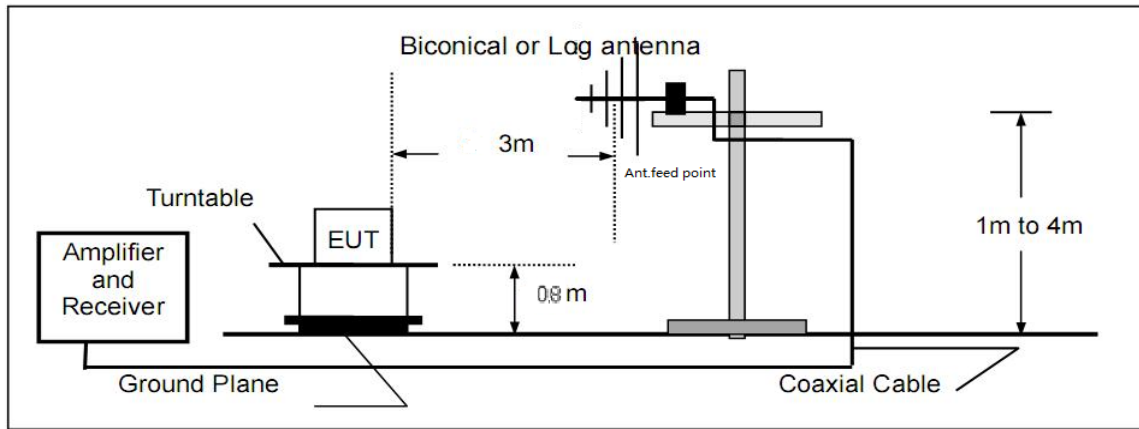

**8.4 TEST RESULT**

The maximum Power (CP) for UHF is

Analog: 2.85W /for 12.5 KHz Channel Separation

Calculation Formula:

$$\text{Emission Level(dBm)} = \text{S.G.(dBm)} - \text{Cable Loss(dB)} + \text{Ant.Gain(dBi)}$$

$$\text{Margin(dB)} = \text{Limit(dBm)} - \text{Emission Level(dBm)}$$

**ERP RESULT:**

Frequency	Reading Level	Antenna	S.G.	Cable Loss	Ant.Gain	Emission Level	Limit	Margin
(MHz)	(dBuv/m)	Polarization	(dBm)	(dB)	(dBi)	(dBm)	(dBm)	(dB)
<b>Frequency: 462.6375MHz</b>								
462.6375	100.83	V	27.76	0.38	6.60	33.98	36.99	3.01
462.6375	99.45	H	26.03	0.38	6.60	32.25	36.99	4.74
<b>Frequency: 467.6375MHz</b>								
467.6375	93.63	V	20.36	0.38	6.60	26.58	27	0.42
467.6375	92.65	H	19.23	0.38	6.60	25.45	27	1.55
<b>Frequency: 462.6500MHz</b>								
462.6500	100.73	V	27.70	0.38	6.60	33.92	36.99	3.07
462.6500	90.76	H	25.79	0.38	6.60	32.01	36.99	4.98



## 9. MODULATION CHARACTERISTICS

### 9.1 PROVISIONS APPLICABLE

According to [FCC Part 95.1775, Part 2.1047(a)], for Voice Modulation Communication Equipment, the frequency response of the audio modulation circuit over a range of 100 to 5000Hz shall be measured.

Part 95.1775(a) A GMRS unit that transmits emission type F3E must not exceed a peak frequency deviation of plus or minus 2.5 kHz, and the audio frequency response must not exceed 3.125 kHz.

Part 2.1047(a) A curve or equivalent data showing the frequency response of the audio modulating circuit over a range of 100 to 5000Hz shall be submitted. For equipment required to have an audio low-pass filter, a curve showing the frequency response of the filter, or of all circuitry installed between the modulation limiter and the modulated stage shall be submitted.

### 9.2 MEASUREMENT METHOD

#### 9.2.1 Modulation Limit

- (1). Configure the EUT as shown in figure 1, adjust the audio input for 60% of rated system deviation at 1KHz using this level as a reference (0dB) and vary the input level from -20 to +20dB. Record the frequency deviation obtained as a function of the input level.
- (2). Repeat step 1 with input frequency changing to 300, 1000, 1500 and 3000Hz in sequence.

#### 9.2.2 Audio Frequency Response

- (1). Configure the EUT as shown in figure 1.
- (2). Adjust the audio input for 20% of rated system deviation at 1 KHz using this level as a reference (0 dB).
- (3). Vary the Audio frequency from 100 Hz to 10 KHz and record the frequency deviation.
- (4). Audio Frequency Response =  $20\log_{10}(\text{Deviation of test frequency}/\text{Deviation of 1 KHz reference})$ .

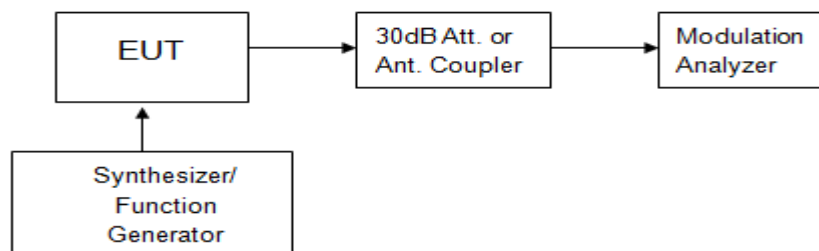

Figure 1: Modulation characteristic measurement configuration

### 9.3 MEASUREMENT RESULT

**TEST CHANNEL: 4**

**(A). MODULATION LIMIT:**

**462.6375MHz @ 12.5 KHz Channel Separations**

Modulation Level (dB)	Peak Freq. Deviation At 300 Hz	Peak Freq. Deviation At 1000 Hz	Peak Freq. Deviation At 1500 Hz	Peak Freq. Deviation At 3000 Hz
-20	0.15	0.41	0.75	0.87
-15	0.26	0.62	0.97	1.15
-10	0.32	0.85	1.29	1.37
-5	0.49	1.13	1.46	1.53
0	0.54	1.35	1.51	1.63
+5	0.68	1.48	1.65	1.72
+10	0.73	1.62	1.76	1.85
+15	0.81	1.63	1.72	1.82
+20	0.93	1.64	1.69	1.79

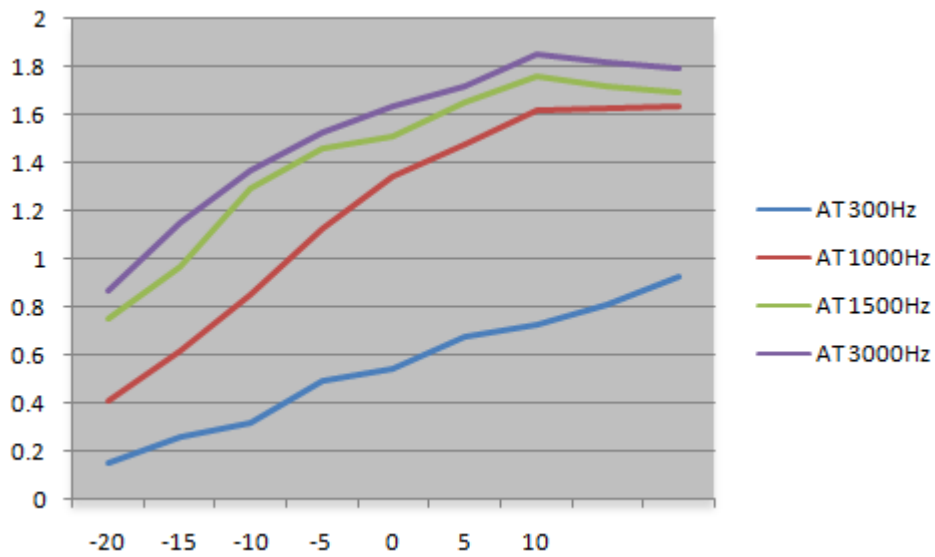

Note: All the modes had been tested, but only the worst data recorded in the report.

**(B). AUDIO FREQUENCY RESPONSE:****462.6375MHz @ 12.5 KHz Channel Separations**

<b>Frequency (Hz)</b>	<b>Deviation (KHz)</b>	<b>Audio Frequency Response(dB)</b>
100	--	--
200	--	--
300	0.16	-9.90
400	0.21	-7.54
500	0.38	-2.38
600	0.42	-1.51
700	0.58	1.29
800	0.61	1.73
900	0.74	3.41
1000	0.88	4.91
1200	0.91	5.20
1400	0.99	5.93
1600	1.07	6.61
1800	1.11	6.93
2000	1.26	8.03
2400	1.37	8.76
2500	1.48	9.43
2800	1.55	9.83
3000	1.76	10.93
3200	1.63	10.26
3600	1.41	9.00
4000	0.95	5.58
4500	0.79	3.97
5000	0.63	2.01
5500	0.51	0.17
6000	0.37	-2.62
6500	0.22	-7.13
7000	0.13	-11.70
7500	0.08	-15.92
9000	--	--
10000	--	--
14000	--	--
18000	--	--
20000	--	--
30000	--	--

**Frequency Response Result**



Note: All the modes had been tested, but only the worst data recorded in the report.

**APPENDIX I: PHOTOGRAPHS OF SETUP**  
**RADIATED EMISSION TEST SETUP**

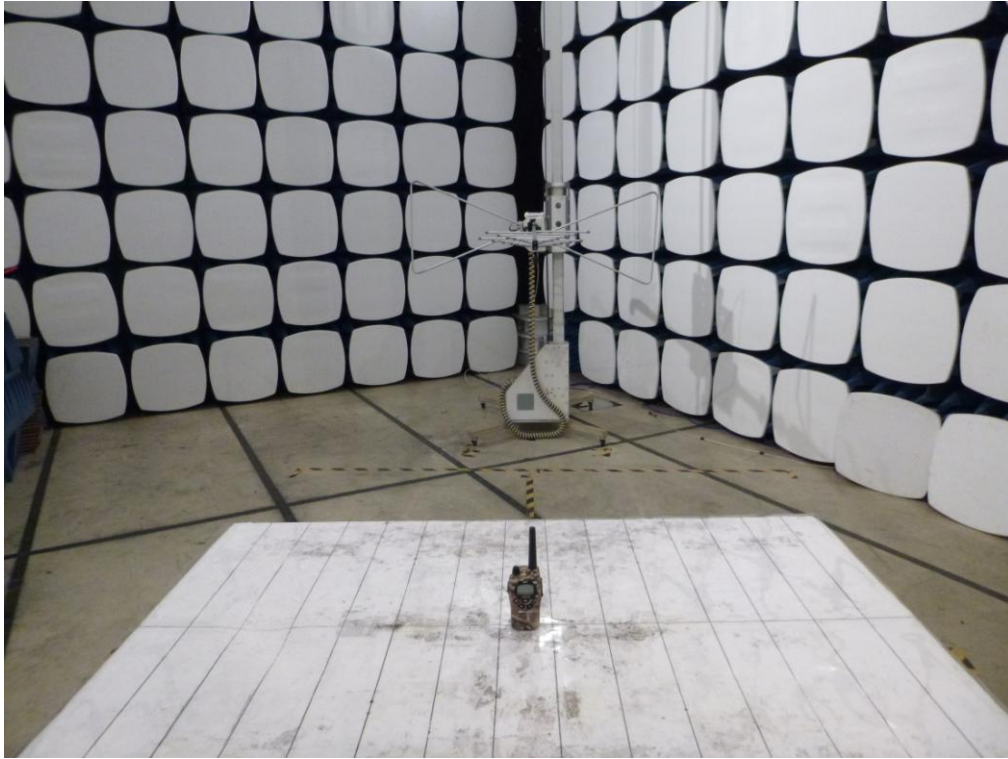

**RADIATED EMISSION ABOVE 1G TEST SETUP**

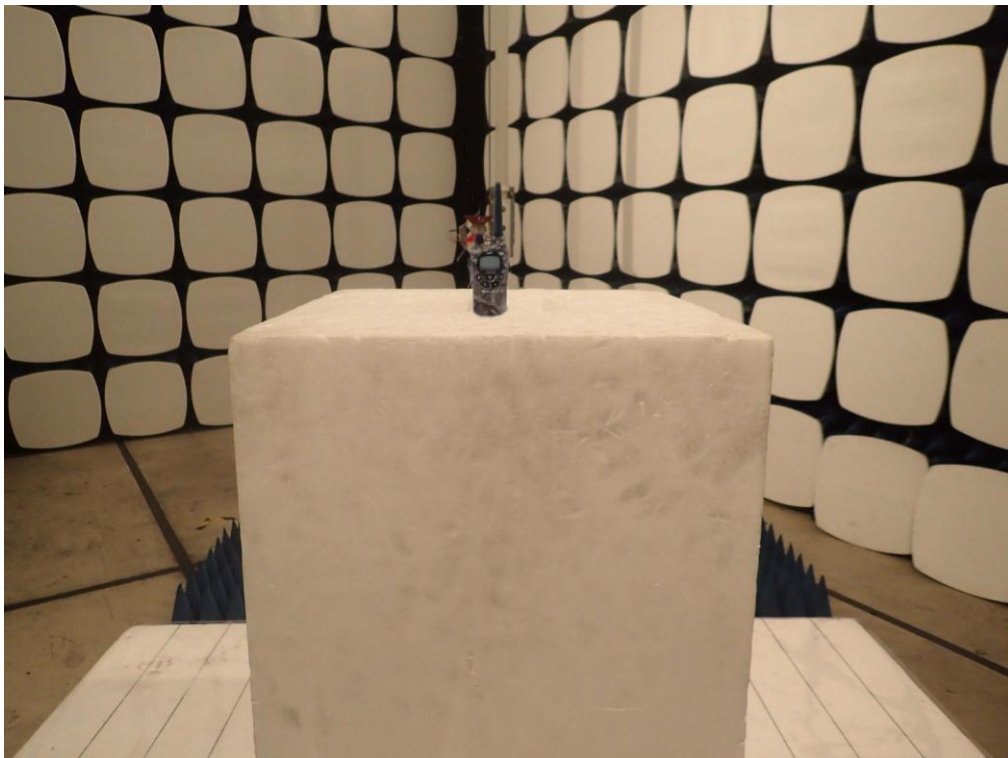

**APPENDIX II: EXTERNAL VIEW OF EUT**  
TOTAL VIEW OF EUT



TOP VIEW OF EUT



BOTTOM VIEW OF EUT



FRONT VIEW OF EUT



BACK VIEW OF EUT



LEFT VIEW OF EUT





RIGHT VIEW OF EUT



OPEN VIEW-1 OF EUT



OPEN VIEW-2 OF EUT

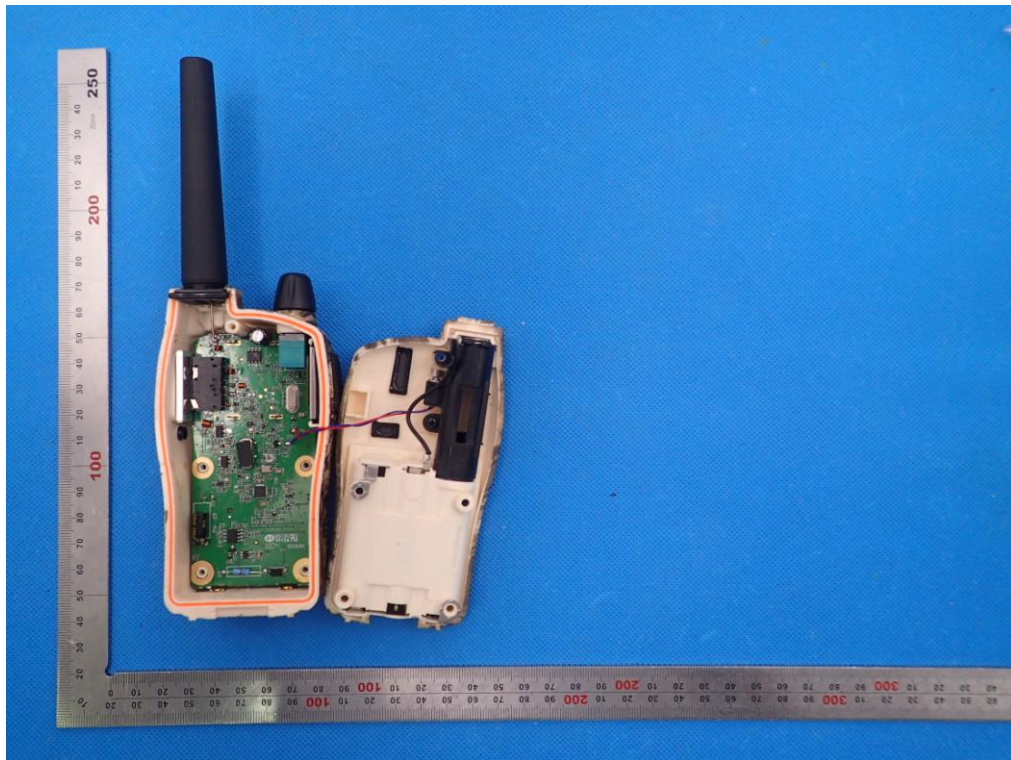

INTERNAL VIEW-1 OF EUT

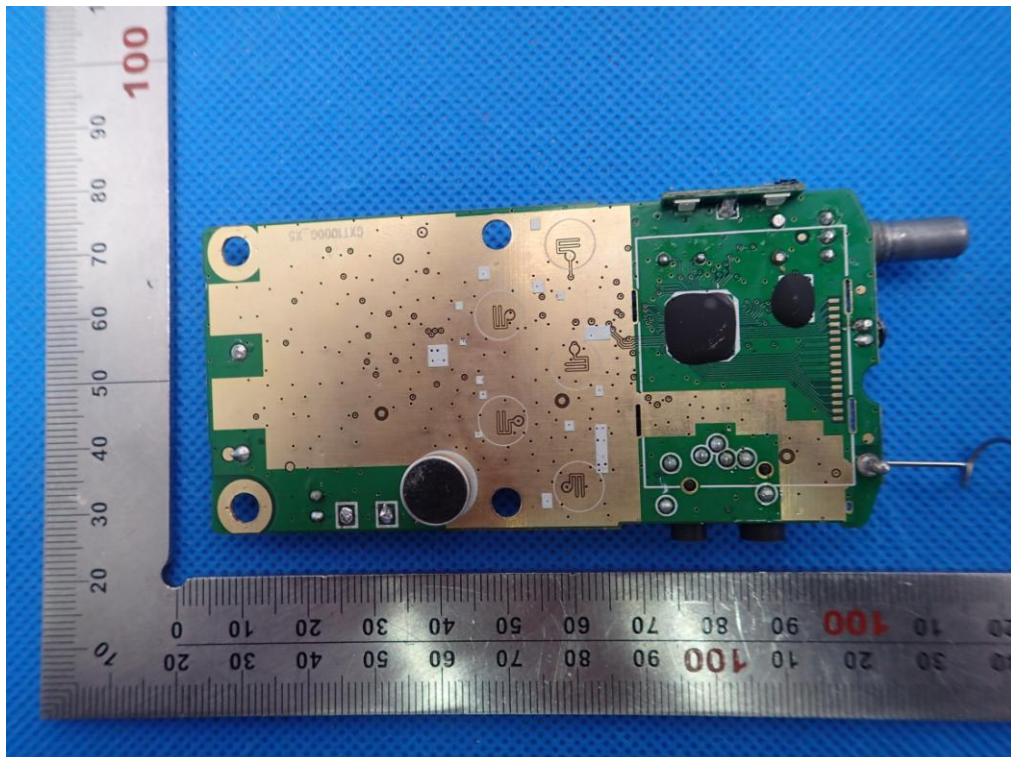

INTERNAL VIEW-2 OF EUT

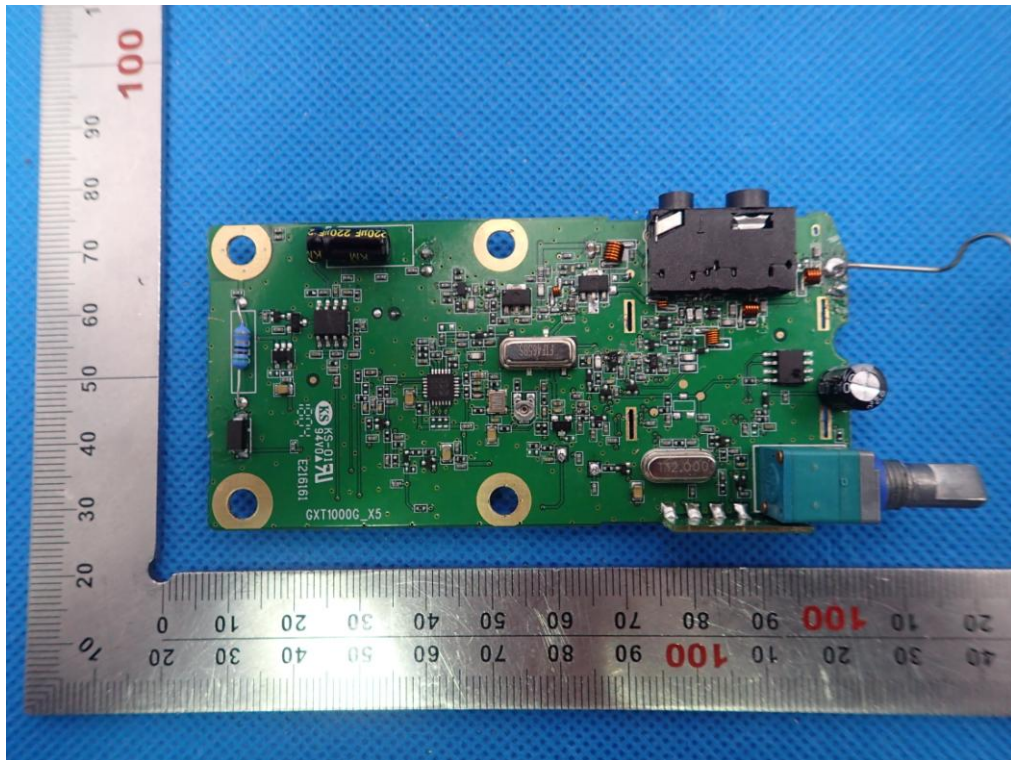

----END OF REPORT----