



849 NW STATE ROAD 45  
NEWBERRY, FL 32669 USA  
PH: 888.472.2424 OR 352.472.5500  
FAX: 352.472.2030  
EMAIL: [INFO@TIMCOENGR.COM](mailto:INFO@TIMCOENGR.COM)  
[HTTP://WWW.TIMCOENGR.COM](http://WWW.TIMCOENGR.COM)

**FCC PART 95 SUBPART D  
TEST REPORT  
FOR CB TRANSCEIVERS**

<b>APPLICANT</b>	MIDLAND RADIO CORPORATION
	5900 PARRETTA DRIVE KANSAS CITY MISSOURI 64120 USA
<b>FCC ID</b>	MMA9001
<b>MODEL NUMBER</b>	9001Z
<b>PRODUCT DESCRIPTION</b>	CB TRANSCEIVER
<b>DATE SAMPLE RECEIVED</b>	1/22/2011
<b>DATE TESTED</b>	2/23/2011
<b>TESTED BY</b>	Joe Scoglio
<b>APPROVED BY</b>	Mario R. de Aranzeta
<b>TIMCO REPORT NO.</b>	134AT11TestReport.doc
<b>TEST RESULTS</b>	<input checked="" type="checkbox"/> PASS <input type="checkbox"/> FAIL

**THE ATTACHED REPORT SHALL NOT BE REPRODUCED EXCEPT IN FULL  
WITHOUT THE WRITTEN APPROVAL OF TIMCO ENGINEERING, INC.**



Testing Certificate # 0955-01



## TABLE OF CONTENTS

GENERAL REMARKS.....	3
GENERAL INFORMATION .....	4
TEST ENVIRONMENT .....	5
TEST SETUP SUMMARY .....	5
TEST EQUIPMENT LIST.....	6
TEST PROCEDURE .....	7
RF POWER OUTPUT .....	8
MODULATION CHARACTERISTICS.....	9
AUDIO FREQUENCY RESPONSE .....	9
AUDIO LOW PASS FILTER RESPONSE .....	10
AUDIO INPUT VS MODULATION.....	11
OCCUPIED BANDWIDTH .....	12
SPURIOUS EMISSIONS AT ANTENNA TERMINALS (CONDUCTED).....	14
FIELD STRENGTH OF SPURIOUS EMISSIONS.....	16
METHOD OF MEASUREMENT.....	18
FREQUENCY STABILITY.....	19

**GENERAL REMARKS**

The attached report shall not be reproduced except in full without the written permission of Timco Engineering Inc.

The test results relate only to the items tested.

**Summary**

The device under test does:

- fulfill the general approval requirements as identified in this test report
- not fulfill the general approval requirements as identified in this test report

**Attestations**

This equipment has been tested in accordance with the standards identified in this test report. To the best of my knowledge and belief, these tests were performed using the measurement procedures described in this report.

All instrumentation and accessories used to test products for compliance to the indicated standards are calibrated regularly in accordance with ISO 17025: 2005 requirements.



Testing Certificate # 0955-01

I attest that the necessary measurements were made, under my supervision, at:

Timco Engineering Inc.  
849 NW State Road 45  
Newberry, Fl 32669



**Authorized Signatory Name:**

Mario de Aranzeta C.E.T.  
Compliance Engineer/ Lab. Supervisor

**Date:** February/23/2011

**GENERAL INFORMATION**

**DUT Specification**

<b>DUT Description</b>	CB TRANSCEIVER
<b>FCC ID</b>	MMA9001
<b>Model Number</b>	9001Z
<b>Serial Number</b>	N/A
<b>Operating Frequency</b>	26.965-27.405 MHz
<b>No. of Channels</b>	40
<b>Type of Emission</b>	6K00A3E Bn = 2M M = 3000 Bn = 6000
<b>Modulation</b>	AM
<b>DUT Power Source</b>	<input type="checkbox"/> 110-120Vac/50- 60Hz
	<input checked="" type="checkbox"/> DC Power
	<input type="checkbox"/> Battery Operated Exclusively
<b>Test Item</b>	<input type="checkbox"/> Prototype
	<input checked="" type="checkbox"/> Pre-Production
	<input type="checkbox"/> Production
<b>Type of Equipment</b>	<input type="checkbox"/> Fixed
	<input checked="" type="checkbox"/> Mobile
	<input type="checkbox"/> Portable



## TEST ENVIRONMENT

Test Facility	Timco Engineering, Inc. 849 NW State Road 45 Newberry, FL 32669 USA.
Test Condition in the laboratory	Temperature: 26°C Relative humidity: 50%

## TEST SETUP SUMMARY

Test Setup Diagram/Description	The DUT was placed on the turntable per setup per ANSI C63.4: 2003. A test set up photo is provided for clarification.
Deviation from the standard/procedure	No deviation
Modification of DUT	No modification
Applicable Standards	EIA/TIA-382-A, FCC CFR 47 PART 95



**TEST EQUIPMENT LIST**

<b>Device</b>	<b>Manufacturer</b>	<b>Model</b>	<b>Serial Number</b>	<b>Cal/Char Date</b>	<b>Due Date</b>
3-Meter Semi-Anechoic Chamber	Panashield	N/A	N/A	Listed 3/10/10	3/10/12
AC Voltmeter	HP	400FL	2213A14499	CAL 3/23/09	3/23/11
Antenna: Dipole Kit	Electro-Metrics	TDA-30/1-4	153	CHAR 6/10/09	6/10/11
Frequency Counter	HP	5385A	3242A07460	CAL 5/26/09	5/26/11
Modulation Analyzer	HP	8901A	3435A06868	CAL 5/26/09	5/26/11
Digital Multimeter	Fluke	FLUKE-77-3	79510405	CAL 5/18/09	5/18/11
Analyzer Tan Tower Preamplifier	HP	8449B-H02	3008A00372	CAL 11/21/09	11/21/11
Analyzer Tan Tower Quasi-Peak Adapter	HP	85650A	3303A01690	CAL 11/22/09	11/22/11
Analyzer Tan Tower RF Preselector	HP	85685A	3221A01400	CAL 11/21/09	11/21/11
Analyzer Tan Tower Spectrum Analyzer	HP	8566B Opt 462	3138A07786 3144A20661	CAL 11/24/09	11/24/11
Temperature Chamber	Tenney Engineering	TTRC	11717-7	CHAR 4/25/10	4/25/12

APPLICANT: MIDLAND RADIO CORPORATION

FCC ID: MMA9001

REPORT #: M\MidlandRadio MMA\134AT11\134AT11TestReport.doc



## TEST PROCEDURE

**Power Line Conducted Interference:** The procedure used was EIA/TIA-382-A using a 50uH LISN. Both lines were observed with the UUT transmitting. The bandwidth of the spectrum analyzer was 10 kHz with an appropriate sweep speed.

**Bandwidth 20 dB:** The measurements were made with the spectrum analyzer's resolution bandwidth (RBW) = 1 MHz and the video bandwidth (VBW) = 3 MHz and the span set as shown on plot.

**Power Output:** The RF power output was measured at the antenna feed point using a peak power meter.

**Antenna Conducted Emissions:** The RBW = 100 kHz, VBW = 300 kHz and the span set to 10.0 MHz and the spectrum was scanned from 30 MHz to the 10<sup>th</sup> Harmonic of the fundamental. Above 1 GHz the resolution bandwidth was 1 MHz and the VBW = 3 MHz and the span to 50 MHz.

**Radiation Interference:** The test procedure used was EIA/TIA-382-A using an Agilent spectrum receiver with pre-selector. The bandwidth (RBW) of the spectrum EIA/TIA-382-A receiver was 100 kHz up to 1 GHz and 1 MHz above 1 GHz with an appropriate sweep speed. The VBW above 1 GHz was 3 MHz. The analyzer was calibrated in dB above a microvolt at the output of the antenna.

## RF POWER OUTPUT

**Rule Part No.:** Part 2.1033(c), Part 95

### Test Requirements:

**Method of Measurement:** RF power is measured by connecting a 50-ohm, resistive wattmeter to the RF output connector. With a nominal battery voltage, and the transmitter properly adjusted the RF output measures:

**Test Data:** OUTPUT POWER: HIGH – 4 Watts

### Test Setup Diagram:

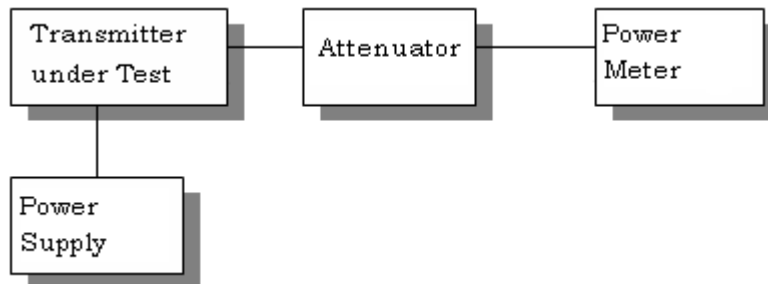

### Part 2.1033 (C)(8) DC Input into the final amplifier

INPUT POWER:  $(13.6V)(1.45A) = 19.72$  Watts



**MODULATION CHARACTERISTICS**

**AUDIO FREQUENCY RESPONSE**

**Rule Part No.:** Part 2.1047(a)(b)

**Method of Measurement:**

The audio frequency response was measured in accordance with EIA/TIA-382-A with no exception. A curve or equivalent data showing the frequency response of the audio modulating circuit over a range of 100 – 5000Hz shall be submitted. The audio frequency response curve is shown below.

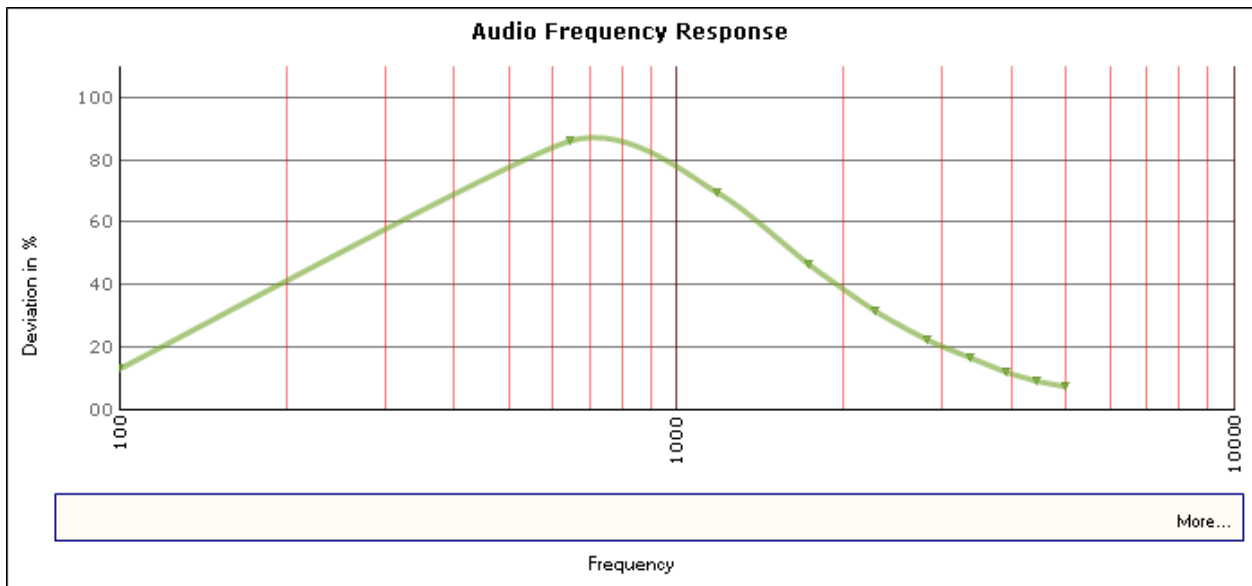

**AUDIO LOW PASS FILTER RESPONSE**

**Rule Part No.:** Part 2.1047(a)(b)

Required for voice modulated communication equipment

For equipment required to have an audio low-pass filter, a curve showing the frequency response of the filter, or of all the circuitry installed between the modulation limiter and the modulated stage shall be submitted.

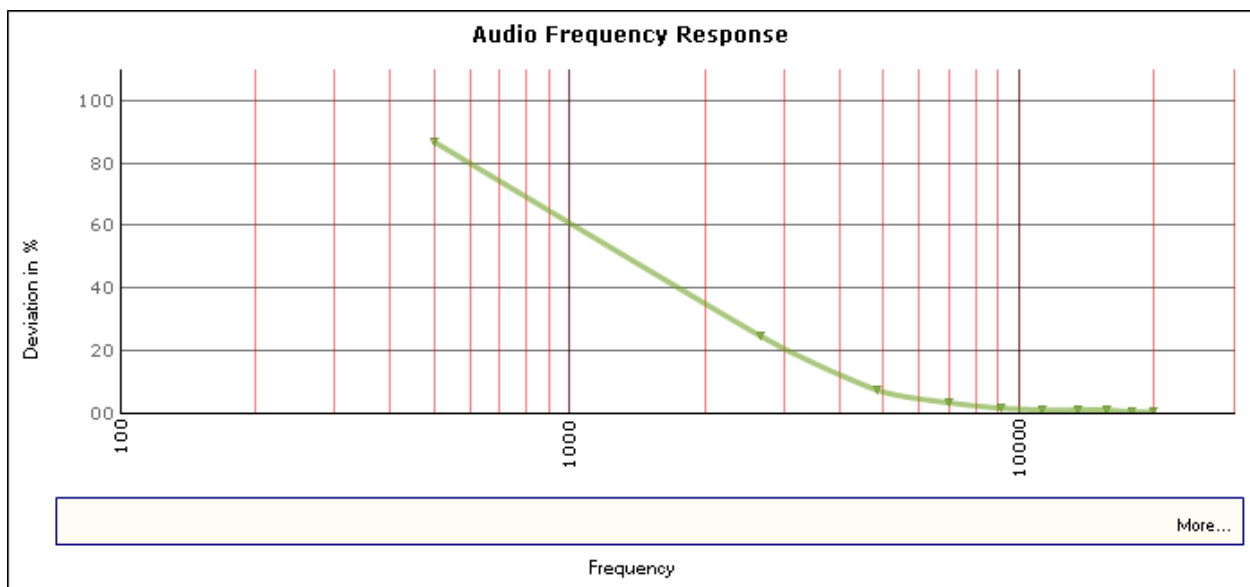

## AUDIO INPUT VS MODULATION

**Rule Part No.:** Part 2.1047(a)(b)

**Test Requirements:** Modulation cannot exceed 100%

**Method of Measurement:** The audio input level needed for a particular percentage of modulation was measured in accordance with EIA/TIA-382-A. The audio input curves versus modulation are shown below. Curves are provided for audio input frequencies of 300, 1000, and 3000 Hz.

**Test data:**

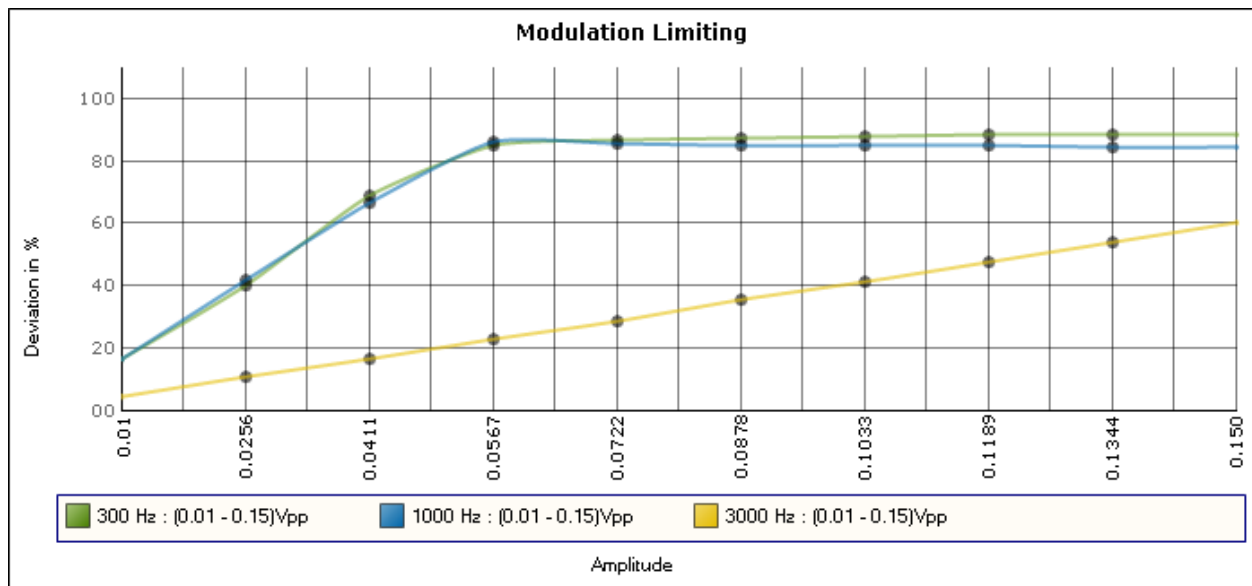

## OCCUPIED BANDWIDTH

### 2.1049

95.631(c) Data in the plots shows that the sidebands from greater than 50% to 100% of the authorized bandwidth must be attenuated by at least 25dB and from 100 to 250% the sidebands must be attenuated by at least 35 dB. Beyond 250% the sidebands must be attenuated by at least  $53 + 10\log(TP)$ . The transmitter was modulated with 2500 Hz, adjusted for 50% modulation plus 16 dB. The spectrum analyzer was set with the un-modulated carrier at the top of the screen. The test procedure diagram and occupied bandwidth photographs follow.

Radiotelephone transmitter with modulation limiter.

Test procedure diagram

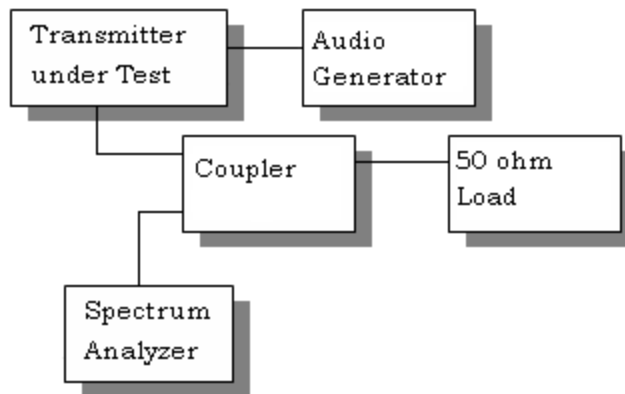

### OCCUPIED BANDWIDTH PLOT

**NOTES:**

MIDLAND RADIO CORPORATION - Model #: 9001  
 OCCUPIED BANDWIDTH PLOT

**FCC 95.635 Mask (1) (3) (8) (9)**

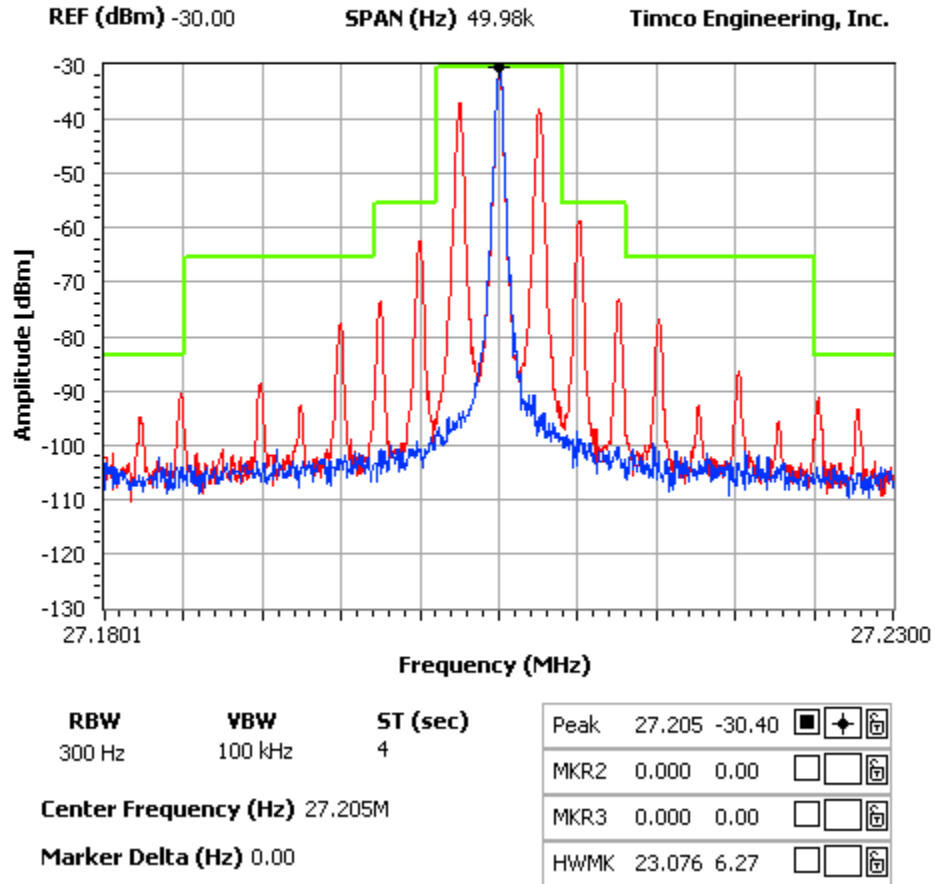



**SPURIOUS EMISSIONS AT ANTENNA TERMINALS (CONDUCTED)**

**Rule Part No.:** Part 2.1051(a), RSS-136

**Requirements:**  $53 + 10\log(4.00) = 59.0\text{dB}$ . Any emissions above 54 MHz must be 60 dBc.

**Method of Measurement:** The carrier was modulated 100% using a 2500 Hz tone. The spectrum was scanned from 0.4 to at least the 10th harmonic of the fundamental. The measurements were made in accordance with standard EIA/TIA-382-A.

**Test Data:**

TF (MHz)	Emission Frequency (MHz)	dB below carrier (dBc)	TF (MHz)	Emission Frequency (MHz)	dB below carrier (dBc)	TF (MHz)	Emission Frequency (MHz)	dB below carrier (dBc)
26.9	53.9	63.4	27.4	54.9	63.4	27.19	54.37	63.4
	80.9	68.9		82.2	68.9		81.56	68.9
	107.8	71.7		109.6	71.7		108.74	71.7
	134.8	67.9		137	67.9		135.93	67.9
	161.8	77.9		164.4	77.9		163.11	77.9
	188.8	82.1		191.8	82.1		190.30	82.1
	215.7	80.9		219.2	80.9		217.48	80.9
	242.7	84.9		246.6	84.9		244.67	84.9
	269.7	76.8		274.1	76.8		271.85	76.8

### Method of Measuring Conducted Spurious Emissions

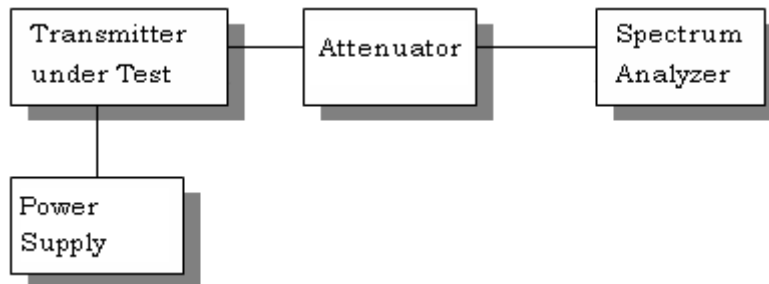

**METHOD OF MEASUREMENT:** The procedure used was EIA/TIA-382-A.



**FIELD STRENGTH OF SPURIOUS EMISSIONS**

**Rule Parts. No.:** Part 2.1053, 95.635(b)(8)(9), RSS-136

**Requirements:** Emissions must be attenuated by at least the following below the output of the transmitter.

53 + 10log(4.00) = 59.0 dB or  
 FCC Limit for: 8 kHz Authorized BW

At least 53+10Log(T) dB on any frequency removed from the center of the authorized bandwidth by more than 250%. At least 60dB on any frequency twice or greater than twice the fundamental.

**Test Data:**

TF (MHz)	Emission Frequency (MHz)	Ant. Polarity	dB Below Carrier (dBc)
26.90	53.90	V	99.07
	80.90	H	105.8
	107.80	H	95.7
	134.80	H	87.4
	161.80	H	98.7
	188.70	H	97.3
	215.70	H	109.9
	242.70	H	90.1
	269.70	H	85.9

TF (MHz)	Emission Frequency (MHz)	Ant. Polarity	dB Below Carrier (dBc)
27.40	54.80	V	100.6
	82.20	H	105.9
	109.60	H	91.9
	137.00	H	91.2
	164.50	H	97.6
	191.90	H	100.4
	219.30	H	109.4
	246.70	H	91.1
	274.10	H	87.8



TF (MHz)	Emission Frequency (MHz)	Ant. Polarity	dB Below Carrier (dBc)
27.1	54.37	V	99.6
	81.56	H	105.6
	108.74	H	93.4
	135.93	H	88.9
	163.11	H	94.7
	190.30	H	97.1
	217.48	H	109.9
	244.67	H	90.1
	271.85	H	86.4

## METHOD OF MEASUREMENT

The tabulated data shows the results of the radiated field strength emissions test. The spectrum was scanned from 30 MHz to at least the tenth harmonic of the fundamental. This test was conducted per EIA/TIA-382-A using the substitution method. Measurements were made at the test site of TIMCO ENGINEERING, INC. located at 849 NW State Road 45, Newberry, FL 32669.

### Test Setup Diagram:

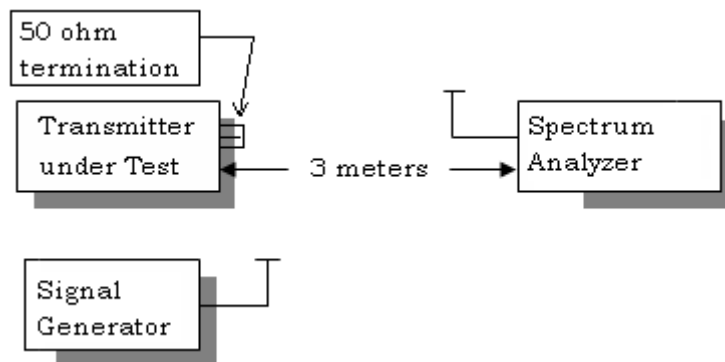

**FREQUENCY STABILITY**

2.1055(a)(b)(d),

Temperature and voltage tests were performed to verify that the frequency remains within the .005%, 50 ppm specification limit. The test was conducted as follows: The transmitter was placed in the temperature chamber at 25 °C and allowed to stabilize for one hour. The transmitter was keyed ON for one minute during which four frequency readings were recorded at 15-second intervals. The worse case number was taken for temperature plotting. The assigned channel frequency was considered to be the reference frequency. The temperature was then reduced to -30 °C after which the transmitter was again allowed to stabilize for one hour. The transmitter was keyed ON for one minute, and again frequency readings were noted at 15-second intervals. The worst case number was recorded for temperature plotting. This procedure was repeated in 10 degree increments up to + 50 °C.

Readings were also taken at ±15% of the battery voltage of 13.8 VDC.

**Test Data:**

<b>Assigned Frequency (Ref. Frequency) (MHz)</b>		
<b>Temperature (°C)</b>	<b>Frequency (MHz)</b>	<b>Frequency Stability (PPM)</b>
-30	27.2046444	-12.13
-20	27.2047632	-7.77
-10	27.2048884	-3.16
0	27.2049556	-0.69
+10	27.204992	0.64
+20	27.2049904	0.58
+30	27.2049795	0.18
+40	27.204987	0.46
+50	27.2050123	1.39

<b>Assigned Frequency (Ref. Frequency) (MHz)</b>		
<b>% Battery</b>	<b>Frequency (MHz)</b>	<b>Frequency Stability (PPM)</b>
-15%	27.2049742	-0.01
0	27.2049742	-0.01
+15%	27.2049741	-0.01