



RADIO TEST REPORT

Report No.: STS2004273W03

Issued for

Orbit Irrigation Products, LLC

845 Overland Road, North Salt Lake, Utah 84058

Product Name:	B-HYVE XR
Brand Name:	Orbit/b-hyve
Model Name:	WT26
Series Model:	N/A
FCC ID:	ML6WT26
IC	3330A-WT26
Test Standard:	FCC Part 15.407 RSS-247 Issue 2, February 2017

Any reproduction of this document must be done in full. No single part of this document may be reproduced without permission from STS, All Test Data Presented in this report is only applicable to presented Test sample.

Shenzhen STS Test Services Co., Ltd.
A 1/F, Building B, Zhuoke Science Park, No.190 Chongqing Road, HepingShequ,
Fuyong Sub-District, Bao'an District, Shenzhen, Guang Dong, China
TEL: +86-755 3688 6288 FAX: +86-755 3688 6277 E-mail: sts@stsapp.com





TEST RESULT CERTIFICATION

Applicant's Name..... : Orbit Irrigation Products, LLC
 Address : 845 Overland Road, North Salt Lake, Utah 84058
Manufacturer's Name..... : Wise Ally Holdings
 Address : Units 3203-3207, Tower 1, Enterprise Square Five, 38 Wang Chiu Road Kowloon Bay

Product Description

Product Name..... : B-HYVE XR
 Brand Name : Orbit/b-hyve
 Model Name : WT26
 Series Model..... : N/A

FCC Part15.407
Test Standards : RSS-247 Issue 2, February 2017
 RSS-Gen Issue 5 ,March 2019

Test Procedure..... ANSI C63.10-2013

This device described above has been tested by STS, the test results show that the equipment under test (EUT) is in compliance with the FCC/IC requirements. And it is applicable only to the tested sample identified in the report.

This report shall not be reproduced except in full, without the written approval of STS, this document only be altered or revised by STS, personal only, and shall be noted in the revision of the document.

Date of Test :
 Date of receipt of test item : 28 Apr. 2020
 Date (s) of performance of tests..... : 28 Apr. 2020 ~ 13 May 2020
 Date of Issue..... : 13 May 2020
 Test Result..... : **Pass**

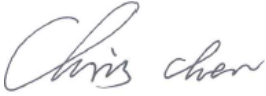
Testing Engineer : 

 (Chris Chen)

Technical Manager : 

 (Sean she)

Authorized Signatory : 

 (Vita Li)

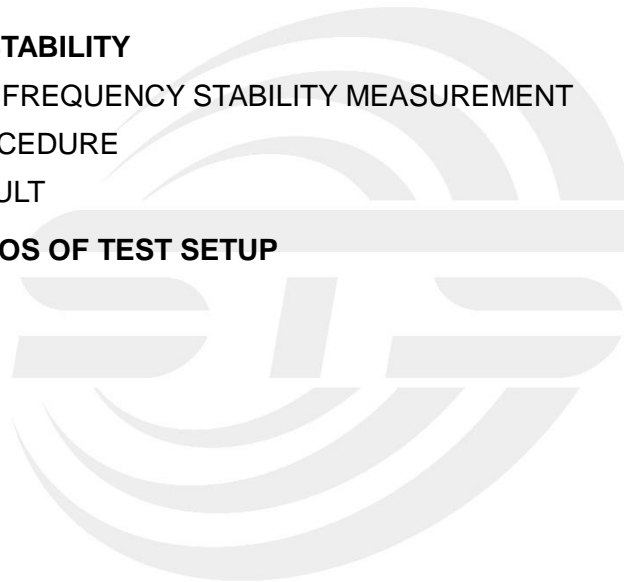



Table of Contents	Page
1 . SUMMARY OF TEST RESULTS	6
1.1 TEST FACTORY	7
1.2 MEASUREMENT UNCERTAINTY	7
2 . GENERAL INFORMATION	8
2.1 GENERAL DESCRIPTION OF THE EUT	8
2.2 DESCRIPTION OF TEST MODES	10
2.3 TEST SOFTWARE AND POWER LEVEL	10
2.4 BLOCK DIGRAM SHOWING THE CONFIGURATION OF SYSTEM TESTED	11
2.5 DESCRIPTION OF NECESSARY ACCESSORIES AND SUPPORT UNITS	12
2.6 EQUIPMENTS LIST FOR ALL TEST ITEMS	13
3 . EMC EMISSION TEST	14
3.1 CONDUCTED EMISSION MEASUREMENT	14
3.2 RADIATED EMISSION AND (BANDEGE) MEASUREMENT	18
4. CONDUCTED SPURIOUS EMISSIONS AND BANDEGE	32
4.1 LIMIT	32
4.2 TEST PROCEDURE	32
4.3 DEVIATION FROM STANDARD	32
4.4 TEST SETUP	33
4.5 EUT OPERATION CONDITIONS	33
4.6 TEST RESULTS	33
5. POWER SPECTRAL DENSITY TEST	34
5.1 LIMIT	34
5.2 TEST PROCEDURE	35
5.3 DEVIATION FROM STANDARD	35
5.4 TEST SETUP	35
5.5 EUT OPERATION CONDITIONS	35
5.6 TEST RESULTS	36
6. BANDWIDTH MEASUREMENT	38
6.1 EMISSION BANDWIDTH (EBW) 26 BANDWID PROCEDURES / LIMIT	38
6.2 OCCUPIED BANDWIDTH (99%) TEST APPLIED PROCEDURES / LIMIT	40
6.3 MINIMUM EMISSION BANDWIDTH(6 DB) PROCEDURES / LIMIT	42
7. MAXIMUM CONDUCTED OUTPUT POWER	44
7.1 LIMIT	44
7.2 TEST PROCEDURE	45



Table of Contents	Page
7.3 DEVIATION FROM STANDARD	45
7.4 TEST SETUP	45
7.5 EUT OPERATION CONDITIONS	45
7.6 TEST RESULTS	46
8. AUTOMATICALLY DISCONTINUE TRANSMISSION	50
8.1 LIMIT OF AUTOMATICALLY DISCONTINUE TRANSMISSION	50
8.2 TEST RESULT OF AUTOMATICALLY DISCONTINUE TRANSMISSION	50
9. ANTENNA REQUIREMENT	51
9.1 STANDARD REQUIREMENT	51
9.2 EUT ANTENNA	51
10. FREQUENCY STABILITY	52
10.1 LIMITS OF FREQUENCY STABILITY MEASUREMENT	52
10.2 TEST PROCEDURE	52
10.3 TEST RESULT	52
APPENDIX - PHOTOS OF TEST SETUP	54





Revision History

Rev.	Issue Date	Report NO.	Effect Page	Contents
00	13 May 2020	STS2004273W03	ALL	Initial Issue





1. SUMMARY OF TEST RESULTS

Test procedures according to the technical standards:

§ 15.407, KDB 789033 D02 General U-NII Test Procedures New Rules v02r01.

FCC Part 15.407 RSS-247 Issue 2, February 2017		
FCC standard	Test Item	Results
15.207 RSS-Gen Issue 5, Amendment 1, March 2019	AC Conducted Emission	PASS
§ 15.407 (2) (26 dB) / § 15.407 (e) (6 dB) / § 15.407 (a) (99%) RSS-Gen Issue 5, Amendment 1, March 2019	26dB/6dB & 99% Bandwidth	PASS
15.407(a) (1).(2).(3).(4).(5) RSS-247 Issue 2, February 2017	Maximum Conducted Output Power	PASS
15.407(b)& 15.209 RSS-247 Issue 2, February 2017	Radiated Emission And (bandedge Emissions) Measurement	PASS
15.407(b)7 RSS-247 Issue 2, February 2017	Conducted Emission And (bandedge Emissions) Measurement	PASS
15.407(a) (1).(2).(3).(4).(5) RSS-247 Issue 2, February 2017	Power Spectral Density	PASS
15.407(c)	Automatically Discontinue Transmission	PASS
15.203/15.204 RSS-Gen Issue 5, Amendment 1, March 2019	Antenna Requirement	PASS
RSS-Gen Issue 5, Amendment 1, March 2019	Frequency Stability	PASS

NOTE:

- (1) 'N/A' denotes test is not applicable in this Test Report.
- (2) All tests are according to ANSI C63.10-2013.



1.1 TEST FACTORY

SHENZHEN STS TEST SERVICES CO., LTD

Add. : A 1/F, Building B, Zhuoke Science Park, No.190 Chongqing Road, HepingShequ, Fuyong Sub-District, Bao'an District, Shenzhen, Guang Dong, China

FCC test Firm Registration Number: 625569

IC test Firm Registration Number: 12108A

A2LA Certificate No.: 4338.01

1.2 MEASUREMENT UNCERTAINTY

The reported uncertainty of measurement $y \pm U$, where expanded uncertainty U is based on a standard uncertainty multiplied by a coverage factor of $k=2$, providing a level of confidence of approximately **95 %**.

No.	Item	Uncertainty
1	RF output power, conducted	$\pm 0.68\text{dB}$
2	Unwanted Emissions, conducted	$\pm 2.988\text{dB}$
3	All emissions, radiated 30-1GHz	$\pm 6.7\text{dB}$
4	All emissions, radiated 1G-6GHz	$\pm 5.5\text{dB}$
5	All emissions, radiated >6G	$\pm 5.8\text{dB}$
6	Conducted Emission (9KHz-150KHz)	$\pm 3.37\text{dB}$
7	Conducted Emission (150KHz-30MHz)	$\pm 3.83\text{dB}$



2. GENERAL INFORMATION

2.1 GENERAL DESCRIPTION OF THE EUT

Product Name	B-HYVE XR				
Trade Name	Orbit/b-hyve				
Model Name	WT26				
Model Differences	Model #	Part #	STATION	Region	Certificates
	WT26	57984	8 STATION	US/CA	FCC
		57994	16 STATION	US/CA	FCC
		57985	8 STATION	US/CA	FCC
		57995	16 STATION	US/CA	FCC
57995 and 57994 are sprinkler irrigation controllers that control up to 16 sprinkler irrigation stations. 57985 and 57984 are sprinkler irrigation controllers that use the same identical hardware, except that for the components for control of 8 stations have been removed, allowing 57985 and 57984 to only control up to 8 stations.					
Product Description	The EUT is a B-HYVE XR				
	Operation Frequency:	IEEE 802.11a/ n(HT20): 5.180GHz-5.240GHz			
		IEEE 802.11n(HT40): 5.190GHz-5.230GHz			
	Modulation Type:	IEEE 802.11a/ n(HT20): 5.745GHz-5.825GHz			
		IEEE 802.11n(HT40): 5.755GHz-5.795GHz			
Antenna Designation:	See Note 3.				
Max.Output Power(Conducted):	3.25dBm				
More details of EUT technical specification, please refer to the User Manual.					
Test Channel	Please refer to the Note 2.				
Power Rating	Input: AC 120V/60Hz Output: AC 24 V/ 1A				
Hardware version number	N/A				
Software version number	N/A				
Connecting I/O Port(s)	Please refer to the Note 1.				

Note:

1. For a more detailed features description, please refer to the manufacturer's specifications or the User Manual.



2. Operation Frequency of channel

5.180GHz-5.240GHz		5.745GHz-5.825GHz	
Channel	Frequency	Channel	Frequency
36	5180	149	5745
38	5190	151	5755
40	5200	153	5765
42	5210	157	5785
44	5220	159	5795
46	5230	161	5805
48	5240	165	5825

Note:

In section 15.31(m), regards to the operating frequency range over 10 MHz, the Lowest frequency, the middle frequency, and the highest frequency of channel were selected to perform the test, and the selected channel see below:

Carrier Frequency Channel

5GHz:

For 802.11a/n(HT20)

Channel	Freq.(MHz)	Channel	Freq.(MHz)
36	5180	149	5745
40	5200	157	5785
48	5240	165	5825

For 802.11n(HT40)

Channel	Freq.(MHz)	Channel	Freq.(MHz)
38	5190	151	5755
46	5230	159	5795

3.

Ant	Brand	Model Name	Ant Type	Connector	Gain (dBi)	NOTE
A	Orbit/b-hyve	WT26	PCB	N/A	5dBi	WLAN Ant.



2.2 DESCRIPTION OF TEST MODES

To investigate the maximum EMI emission characteristics generates from EUT, the test system was pre-scanning tested base on the consideration of following EUT operation mode or test configuration mode which possible have effect on EMI emission level. Each of these EUT operation mode(s) or test configuration mode(s) mentioned above was evaluated respectively.

Worst Mode	Description	Data Rate
Mode 1	TX IEEE 802.11a HT20 CH36&CH40&CH48	6 Mbps
Mode 2	TX IEEE 802.11a HT20 CH149&CH157&CH165	6 Mbps
Mode 3	TX IEEE 802.11n HT20 CH36&CH40&CH48	MCS 0
Mode 4	TX IEEE 802.11n HT20 CH149&CH157&CH165	MCS 0
Mode 5	TX IEEE 802.11n HT40 CH38&CH46	MCS 0
Mode 6	TX IEEE 802.11n HT40 CH151&CH159	MCS 0

- Note: (1) The measurements are performed at the highest, middle, lowest available channels.
 (2) The measurements are performed at all Bit Rate of Transmitter, the worst data was reported.
 (3) We have be tested for all avaiable U.S. voltage and frequencies(For 120V,50/60Hz and 240V, 50/60Hz) for which the device is capable of operation.

AC Conducted Emission

Test Case	
AC Conducted Emission	Mode 7: Keeping TX + WLAN Link

2.3 TEST SOFTWARE AND POWER LEVEL

During testing channel & power controlling software provided by the customer was used to control the operating channel as well as the output power level.

RF Function	Type	Mode Or Modulation type	Ant Gain(dBi)	Power Class	Software For Testing
WIFI(5G)	5G WIFI Band1 (5150MHz-5250MHz)	802.11a	5	15	PM Comm Gui Version:0001
		802.11n(HT20)		15	
		802.11n(HT40)		15	
	5G WIFI Band4 (5725MHz-5875MHz)	802.11a	5	15	
		802.11n(HT20)		15	
		802.11n(HT40)		15	

2.4 BLOCK DIGRAM SHOWING THE CONFIGURATION OF SYSTEM TESTED

Radiated Spurious Emission Test

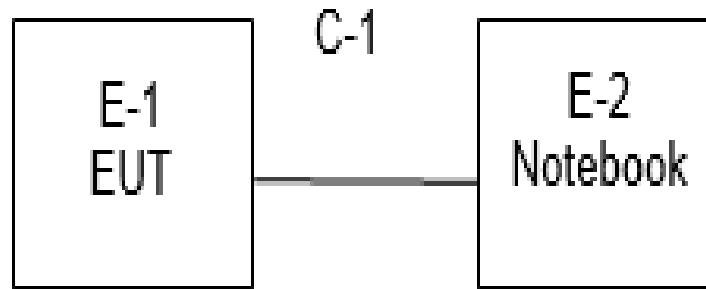

Conducted Emission Test

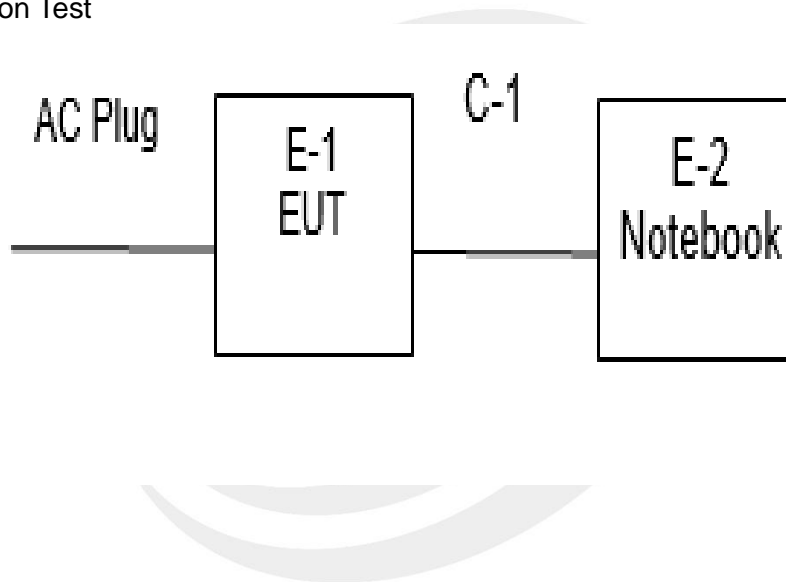



2.5 DESCRIPTION OF NECESSARY ACCESSORIES AND SUPPORT UNITS

The EUT has been tested as an independent unit together with other necessary accessories or support units. The following support units or accessories were used to form a representative test configuration during the tests.

Necessary accessories

Item	Equipment	Mfr/Brand	Model/Type No.	Serial No.	Note
N/A	N/A	N/A	N/A	N/A	N/A

Support units

Item	Equipment	Mfr/Brand	Model/Type No.	Serial No.	Note
E-2	Notebook	DELL	VOSTRO.3800	N/A	N/A
C-1	DC Cable	N/A	100cm	N/A	N/A

Note:

- (1) The support equipment was authorized by Declaration of Confirmation.
- (2) For detachable type I/O cable should be specified the length in cm in 『Length』 column.



2.6 EQUIPMENTS LIST FOR ALL TEST ITEMS

Radiation Test equipment

Kind of Equipment	Manufacturer	Type No.	Serial No.	Last calibration	Calibrated until
EMI Test Receiver	R&S	ESCI	101427	2019.07.29	2020.07.28
Signal Analyzer	Agilent	N9020A	MY51110105	2020.03.05	2021.03.04
Active loop Antenna	ZHINAN	ZN30900C	16035	2018.03.11	2021.03.10
Bilog Antenna	TESEQ	CBL6111D	34678	2017.11.02	2020.11.01
Horn Antenna	SCHWARZBECK	BBHA 9120D(1201)	9120D-1343	2018.10.19	2021.10.18
Horn Antenna (18-40GHz)	A-INFO	LB-180400-KF	J211020657	2018.03.11	2021.03.10
Pre-mpifier (18G-40G)	SKET	LNPA_1840-50	SK2018101801	2019.10.22	2020.10.21
Spectrum Analyzer	R&S	FSV40-N	101823	2019.06.05	2020.06.04
Pre-Amplifier(0.1 M-3GHz)	EM	EM330	060665	2019.10.09	2020.10.08
Pre-Amplifier (1G-18GHz)	SKET	LNPA-01018G-4 5	SK2018080901	2019.10.12	2020.10.11
Temperature & Humidity	HH660	Mieo	N/A	2019.10.12	2020.10.11
Turn table	EM	SC100_1	60531	N/A	N/A
Antenna mast	EM	SC100	N/A	N/A	N/A
Test SW	BULUN	BL410-E/18.905			

Conduction Test equipment

Kind of Equipment	Manufacturer	Type No.	Serial No.	Last calibration	Calibrated until
Test Receiver	R&S	ESCI	101427	2019.07.29	2020.07.28
LISN	R&S	ENV216	101242	2019.10.09	2020.10.08
LISN	EMCO	3810/2NM	23625	2019.10.09	2020.10.08
Temperature & Humidity	HH660	Mieo	N/A	2019.10.12	2020.10.11
Test SW	FARAD	EZ-EMC(Ver.STSLAB-03A1 CE)			

RF Connected Test

Kind of Equipment	Manufacturer	Type No.	Serial No.	Last calibration	Calibrated until
USB RF power sensor	DARE	RPR3006W	15I00041SNO03	2019.10.09	2020.10.08
Signal Analyzer	Agilent	N9020A	MY49100060	2019.10.09	2020.10.08
Temperature & Humidity	HH660	Mieo	N/A	2019.10.12	2020.10.11
Test SW	FARAD	LZ-RF /LzRf-3A3			



3. EMC EMISSION TEST

3.1 CONDUCTED EMISSION MEASUREMENT

3.1.1 POWER LINE CONDUCTED EMISSION Limits (Frequency Range 150KHz-30MHz)

FREQUENCY (MHz)	Class B (dBuV)		Standard
	Quasi-peak	Average	
0.15 -0.5	66 - 56 *	56 - 46 *	CISPR
0.50 -5.0	56.00	46.00	CISPR
5.0 -30.0	60.00	50.00	CISPR

0.15 -0.5	66 - 56 *	56 - 46 *	FCC
0.50 -5.0	56.00	46.00	FCC
5.0 -30.0	60.00	50.00	FCC

Note:

- (1) The tighter limit applies at the band edges.
- (2) The limit of “ * ” marked band means the limitation decreases linearly with the logarithm of the frequency in the range.

The following table is the setting of the receiver

Receiver Parameters	Setting
Attenuation	10 dB
Start Frequency	0.15 MHz
Stop Frequency	30 MHz
IF Bandwidth	9 kHz

3.1.2 TEST PROCEDURE

- a. The EUT was placed 0.8 meters from the horizontal ground plane with EUT being connected to the power mains through a line impedance stabilization network (LISN). All other support equipments powered from additional LISN(s). The LISN provide 50 Ohm/ 50uH of coupling impedance for the measuring instrument.
- b. Interconnecting cables that hang closer than 40 cm to the ground plane shall be folded back and forth in the center forming a bundle 30 to 40 cm long.
- c. I/O cables that are not connected to a peripheral shall be bundled in the center. The end of the cable may be terminated, if required, using the correct terminating impedance. The overall length shall not exceed 1 m.
- d. LISN at least 80 cm from nearest part of EUT chassis.
- e. For the actual test configuration, please refer to the related Item –EUT Test Photos.

3.1.3 DEVIATION FROM TEST STANDARD

No deviation

3.1.4 TEST SETUP

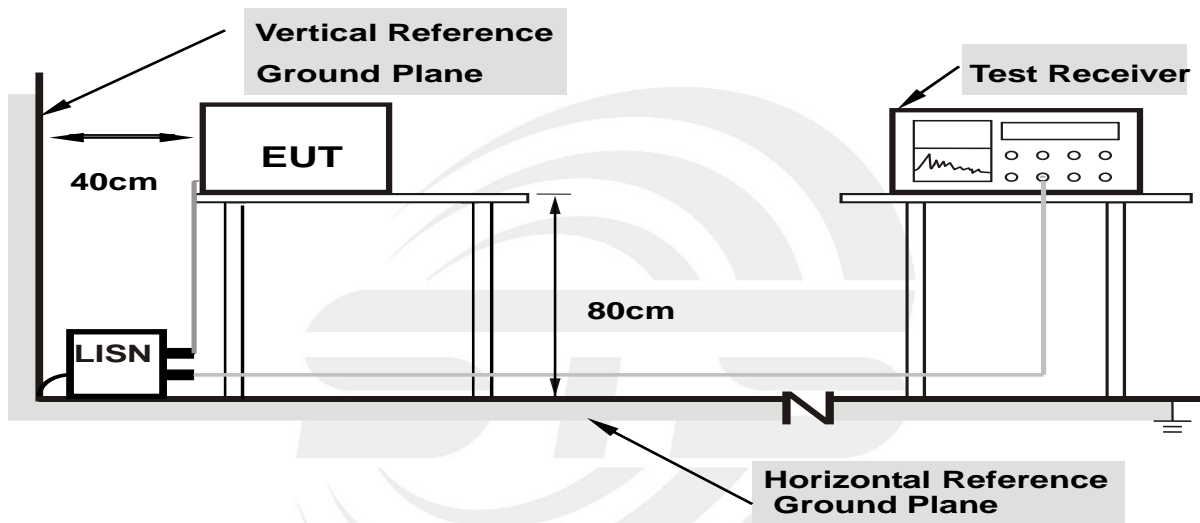

- Note: 1.Support units were connected to second LISN.**
2.Both of LISNs (AMN) are 80 cm from EUT and at least 80 from other units and other metal planes

3.1.5 EUT OPERATING CONDITIONS

The EUT was configured for testing in a typical fashion (as a customer would normally use it). The EUT has been programmed to continuously transmit during test. This operating condition was tested and used to collect the included data.



3.1.6 TEST RESULTS

Temperature:	26.4(C)	Relative Humidity:	68%RH
Test Voltage:	AC 120V/60Hz	Phase:	L
Test Mode :	Mode 7		

No.	Frequency (MHz)	Reading (dBuV)	Correct Factor(dB)	Result (dBuV)	Limit (dBuV)	Margin (dB)	Remark
1	0.1540	14.11	19.73	33.84	65.78	-31.94	QP
2	0.1540	-1.46	19.73	18.27	55.78	-37.51	AVG
3	0.5340	8.18	19.92	28.10	56.00	-27.90	QP
4	0.5340	-4.00	19.92	15.92	46.00	-30.08	AVG
5	1.0620	8.81	19.75	28.56	56.00	-27.44	QP
6	1.0620	-4.47	19.75	15.28	46.00	-30.72	AVG
7	3.0300	6.58	19.85	26.43	56.00	-29.57	QP
8	3.0300	-3.91	19.85	15.94	46.00	-30.06	AVG
9	7.5460	7.01	19.81	26.82	60.00	-33.18	QP
10	7.5460	-3.49	19.81	16.32	50.00	-33.68	AVG
11	22.8700	22.56	20.17	42.73	60.00	-17.27	QP
12	22.8700	-4.06	20.17	16.11	50.00	-33.89	AVG

Remark:

1. All readings are Quasi-Peak and Average values.
2. Margin = Result (Result =Reading + Factor) –Limit

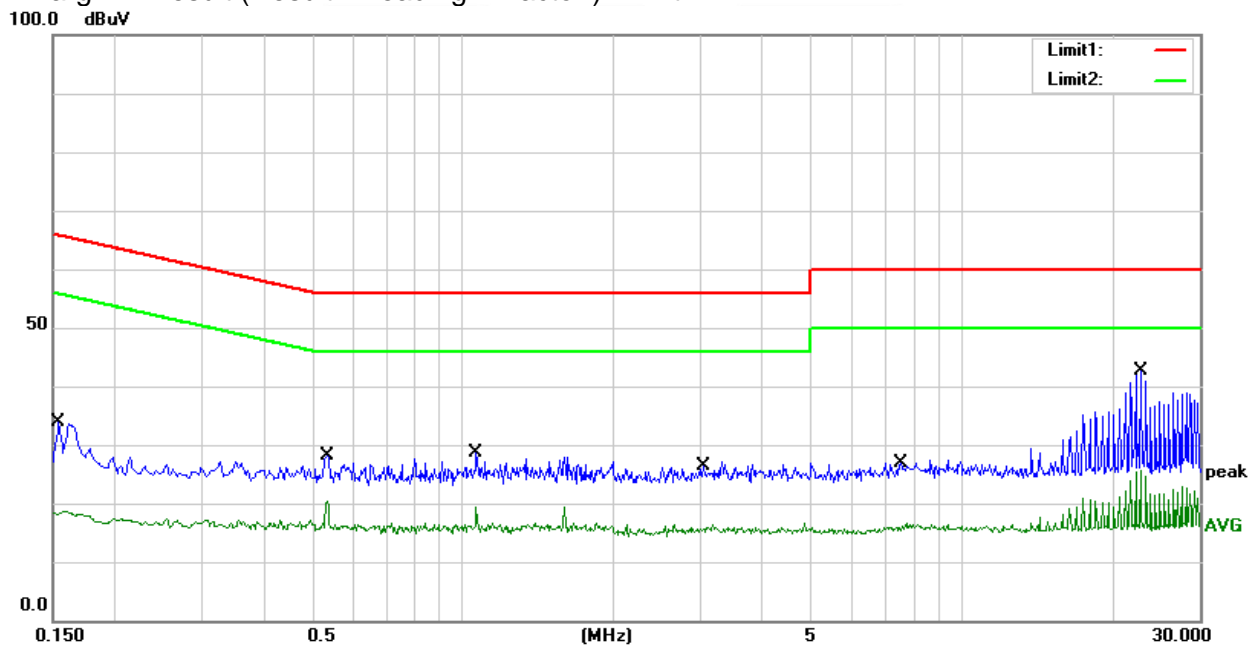



Temperature:	26.4(C)	Relative Humidity:	68%RH
Test Voltage	AC 120V/60Hz	Phase:	N
Test Mode	Mode 7		

No.	Frequency (MHz)	Reading (dBuV)	Correct Factor(dB)	Result (dBuV)	Limit (dBuV)	Margin (dB)	Remark
1	0.1500	15.10	19.72	34.82	66.00	-31.18	QP
2	0.1500	-1.08	19.72	18.64	56.00	-37.36	AVG
3	0.5340	8.11	19.92	28.03	56.00	-27.97	QP
4	0.5340	-3.92	19.92	16.00	46.00	-30.00	AVG
5	1.6980	7.62	19.80	27.42	56.00	-28.58	QP
6	1.6980	-4.12	19.80	15.68	46.00	-30.32	AVG
7	5.0860	6.88	19.85	26.73	60.00	-33.27	QP
8	5.0860	-4.43	19.85	15.42	50.00	-34.58	AVG
9	13.8300	10.23	19.91	30.14	60.00	-29.86	QP
10	13.8300	-4.66	19.91	15.25	50.00	-34.75	AVG
11	22.8740	22.38	20.17	42.55	60.00	-17.45	QP
12	22.8740	-3.17	20.17	17.00	50.00	-33.00	AVG

Remark:

1. All readings are Quasi-Peak and Average values.
2. Margin = Result (Result =Reading + Factor) –Limit

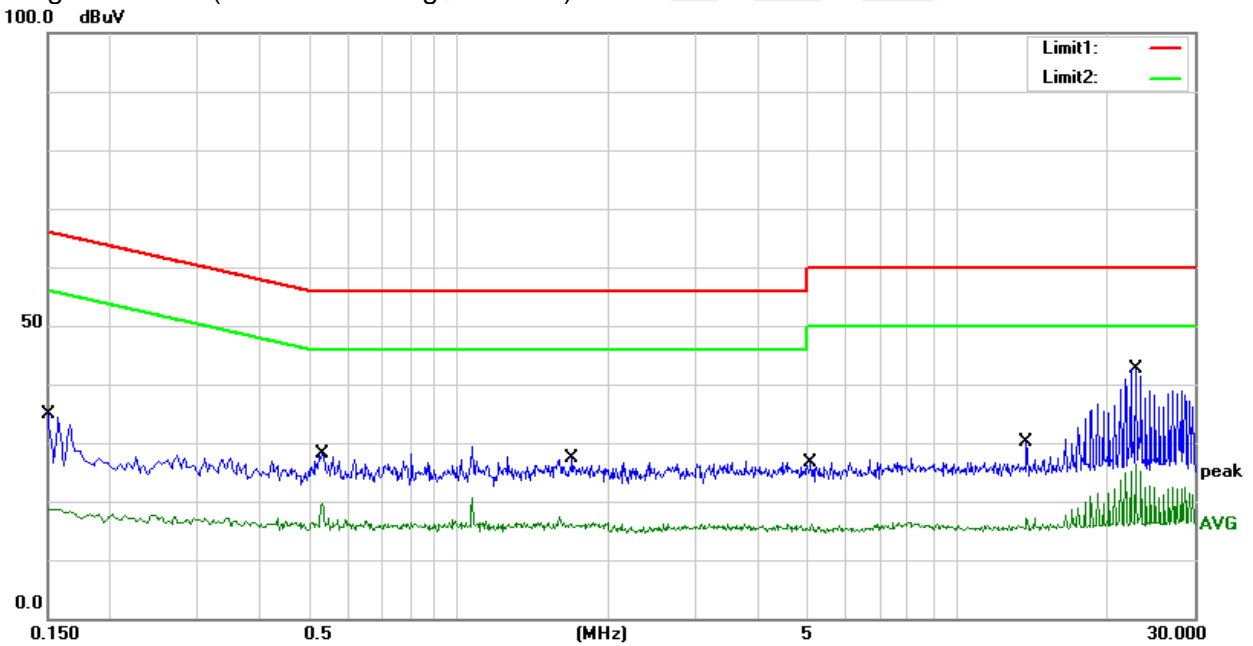



3.2 RADIATED EMISSION AND (BANDEDGE) MEASUREMENT

3.2.1 RADIATED EMISSION LIMITS (Frequency Range 9kHz-1000MHz)

In case the emission fall within the restricted band; limit in the table below has to be followed.

Frequencies (MHz)	Field Strength (microrvolts/meter)	Measurement Distance (meters)
0.009~0.490	2400/F(KHz)	300
0.490~1.705	24000/F(KHz)	30
1.705~30.0	30	30
30~88	100	3
88~216	150	3
216~960	200	3
Above 960	500	3

LIMITS OF RADIATED EMISSION MEASUREMENT (Above 1000MHz)

FREQUENCY (MHz)	Class B (dBuV/m) (at 3M)	
	PEAK	AVERAGE
Above 1000	68.2	54

Notes:

- (1) The limit for radiated test was performed according to FCC PART 15E.
- (2) The tighter limit applies at the band edges.
- (3) Emission level (dBuV/m)=20log Emission level (uV/m).

LIMITS OF RESTRICTED FREQUENCY BANDS

FCC:

FREQUENCY (MHz)	FREQUENCY (MHz)	FREQUENCY (MHz)	FREQUENCY (GHz)
0.090-0.110	16.42-16.423	399.9-410	4.5-5.15
0.495-0.505	16.69475-16.69525	608-614	5.35-5.46
2.1735-2.1905	16.80425-16.80475	960-1240	7.25-7.75
4.125-4.128	25.5-25.67	1300-1427	8.025-8.5
4.17725-4.17775	37.5-38.25	1435-1626.5	9.0-9.2
4.20725-4.20775	73-74.6	1645.5-1646.5	9.3-9.5
6.215-6.218	74.8-75.2	1660-1710	10.6-12.7
6.26775-6.26825	108-121.94	1718.8-1722.2	13.25-13.4
6.31175-6.31225	123-138	2200-2300	14.47-14.5
8.291-8.294	149.9-150.05	2310-2390	15.35-16.2
8.362-8.366	156.52475-156.52525	2483.5-2500	17.7-21.4
8.37625-8.38675	156.7-156.9	2690-2900	22.01-23.12
8.41425-8.41475	162.0125-167.17	3260-3267	23.6-24.0
12.29-12.293	167.72-173.2	3332-3339	31.2-31.8
12.51975-12.52025	240-285	3345.8-3358	36.43-36.5
12.57675-12.57725	322-335.4	3600-4400	Above 38.6
13.36-13.41			



IC:

FREQUENCY (MHz)	FREQUENCY (MHz)	FREQUENCY (GHz)
0.090 - 0.110	149.9 - 150.05	9.0 - 9.2
0.495 - 0.505	156.52475 - 156.52525	9.3 - 9.5
2.1735 - 2.1905	156.7 - 156.9	10.6 - 12.7
3.020 - 3.026	162.0125 - 167.17	13.25 - 13.4
4.125 - 4.128	167.72 - 173.2	14.47 - 14.5
4.17725 - 4.17775	240 - 285	15.35 - 16.2
4.20725 - 4.20775	322 - 335.4	17.7 - 21.4
5.677 - 5.683	399.9 - 410	22.01 - 23.12
6.215 - 6.218	608 - 614	23.6 - 24.0
6.26775 - 6.26825	960 - 1427	31.2 - 31.8
6.31175 - 6.31225	1435 - 1626.5	36.43 - 36.5
8.291 - 8.294	1645.5 - 1646.5	Above 38.6
8.362 - 8.366	1660 - 1710	
8.37625 - 8.38675	1718.8 - 1722.2	
8.41425 - 8.41475	2200 - 2300	
12.29 - 12.293	2310 - 2390	
12.51975 - 12.52025	2483.5 - 2500	
12.57675 - 12.57725	2655 - 2900	
13.36 - 13.41	3260 - 3267	
16.42 - 16.423	3332 - 3339	
16.69475 - 16.69525	3345.8 - 3358	
16.80425 - 16.80475	3500 - 4400	
25.5 - 25.67	4500 - 5150	
37.5 - 38.25	5350 - 5460	
73 - 74.6	7250 - 7750	
74.8 - 75.2	8025 - 8500	
108 - 138		

Spectrum Parameter	Setting
Attenuation	Auto
Detector	Peak
Start Frequency	1000 MHz(Peak/AV)
Stop Frequency	10th carrier harmonic (Peak/AV)
RB / VB (emission in restricted band)	1 MHz / 1 MHz, AV=1 MHz /3 MHz



For Band edge

Spectrum Parameter	Setting
Detector	Peak
RB / VB (emission in restricted band)	1 MHz / 1 MHz, AV=1 MHz /3 MHz

Receiver Parameter	Setting
Attenuation	Auto
Start ~ Stop Frequency	9kHz~90kHz / RB 200Hz for PK & AV
Start ~ Stop Frequency	90kHz~110kHz / RB 200Hz for QP
Start ~ Stop Frequency	110kHz~490kHz / RB 200Hz for PK & AV
Start ~ Stop Frequency	490kHz~30MHz / RB 9kHz for QP
Start ~ Stop Frequency	30MHz~1000MHz / RB 120kHz for QP

3.2.2 TEST PROCEDURE

- The measuring distance of at 3 m shall be used for measurements at frequency 0.009MHz up to 1GHz. For frequencies above 1GHz, any suitable measuring distance may be used.
- The EUT was placed on the top of a rotating table 0.8 meters(above 1GHz is 1.5 m) above the ground at a 3 meter anechoic chamber. The table was rotated 360 degrees to determine the position of the highest radiation.
- The height of the equipment shall be 0.8 m(above 1GHz is 1.5 m); the height of the test antenna shall vary between 1 m to 4 m. Horizontal and vertical polarizations of the antenna are set to make the measurement.
- The initial step in collecting conducted emission data is a spectrum analyzer peak detector mode pre-scanning the measurement frequency range. Significant peaks are then marked and then Quasi Peak detector mode re-measured.
- If the Peak Mode measured value compliance with and lower than Quasi Peak Mode Limit, the EUT shall be deemed to meet QP Limits and then no additional QP Mode measurement performed.
- For the actual test configuration, please refer to the related Item –EUT Test Photos.

Note:

Both horizontal and vertical antenna polarities were tested and performed test to three orthogonal axis. The worst case emissions were reported.

3.2.2 DEVIATION FROM TEST STANDARD

No deviation

3.2.3 TEST SETUP

(A) Radiated Emission Test-Up Frequency Below 30MHz

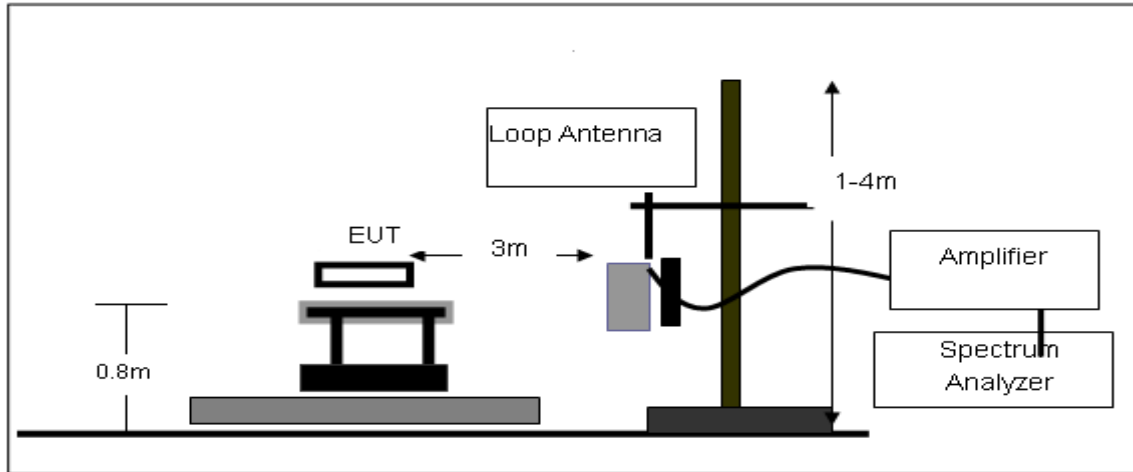

(B) Radiated Emission Test-Up Frequency 30MHz~1GHz

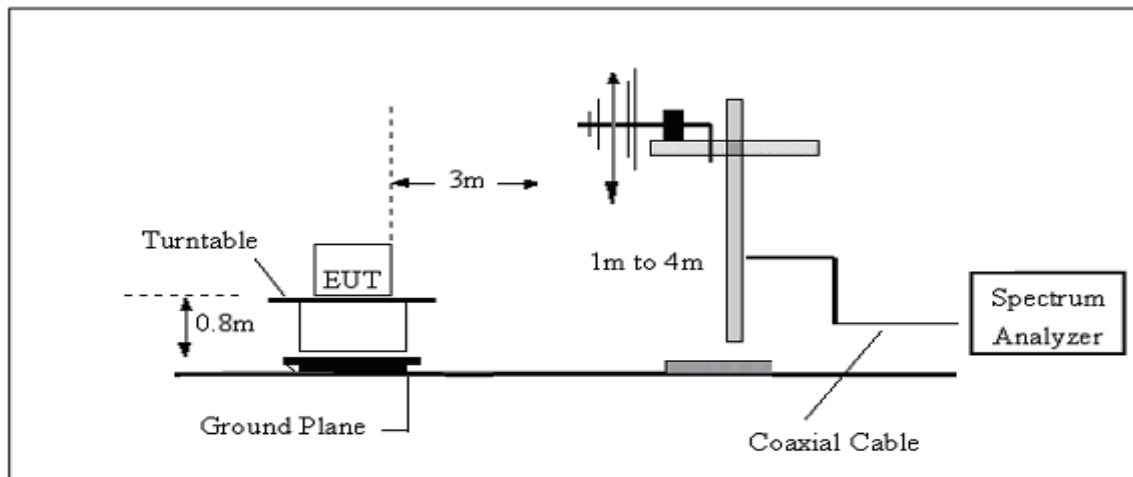

(C) Radiated Emission Test-Up Frequency Above 1GHz

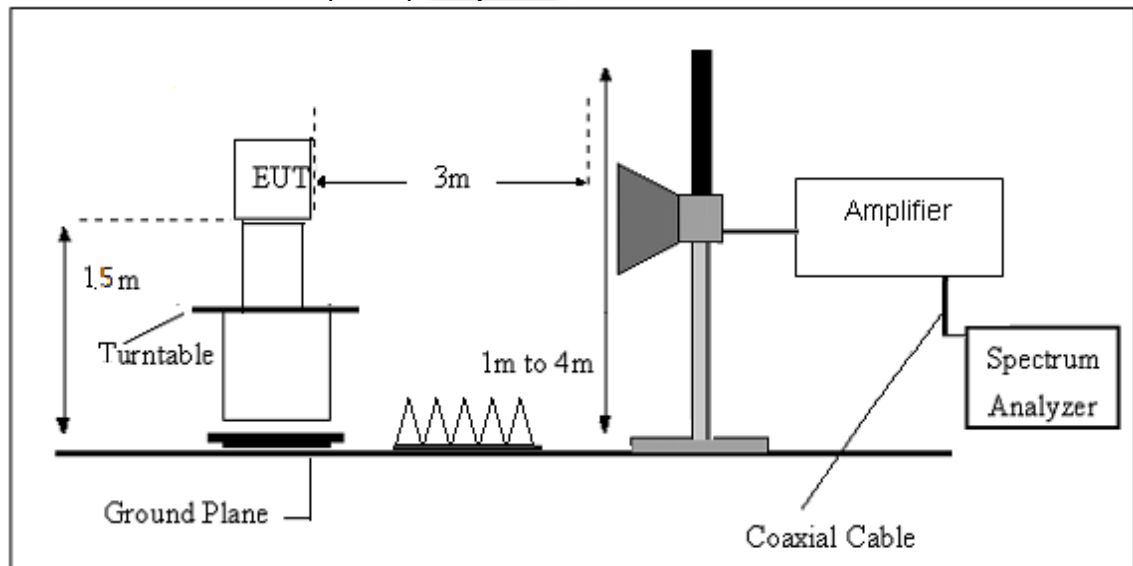



3.2.4 EUT OPERATING CONDITIONS

The EUT tested system was configured as the statements of 2.4 Unless otherwise a special operating condition is specified in the follows during the testing.

3.2.5 FIELD STRENGTH CALCULATION

The field strength is calculated by adding the Antenna Factor and Cable Factor and subtracting the Amplifier Gain and Duty Cycle Correction Factor (if any) from the measured reading. The basic equation with a sample calculation is as follows:

$$FS = RA + AF + CL - AG$$

Where

FS = Field Strength

CL = Cable Attenuation Factor (Cable Loss)

RA = Reading Amplitude

AG = Amplifier Gain

AF = Antenna Factor

For example

Frequency (MHz)	FS (dB μ V/m)	RA (dB μ V/m)	AF (dB)	CL (dB)	AG (dB)	Factor (dB)
300	40	58.1	12.2	1.6	31.9	-18.1

$$\text{Factor} = \text{AF} + \text{CL} - \text{AG}$$

**3.2.6 TEST RESULTS (Between 9KHz – 30 MHz)**

Temperature:	23.4(C)	Relative Humidity:	52%RH
Test Voltage :	AC 120V/60Hz	Polarization :	--
Test Mode :	TX Mode		

Freq. (MHz)	Reading (dBuV/m)	Limit (dBuV/m)	Margin (dB)	State P/F
--	--	--	--	PASS
--	--	--	--	PASS

Note:

The amplitude of spurious emissions which are attenuated by more than 20dB below the permissible value has no need to be reported.

Distance extrapolation factor = $40 \log(\text{specific distance}/\text{test distance})$ (dB);

Limit line = specific limits(dBuv) + distance extrapolation factor.



3.2.7 TEST RESULTS (Between 30MHz – 1GHz)

Temperature	23.4(C)	Relative Humidity:	52%RH
Test Voltage	AC 120V/60Hz	Polarization:	Horizontal
Test Mode	Mode 1~6(Mode 1 worst mode)		

No.	Frequency (MHz)	Reading (dBuV)	Correct Factor(dB/m)	Result (dBuV/m)	Limit (dBuV/m)	Margin (dB)	Remark
1	30.0000	28.32	-12.85	15.47	40.00	-24.53	QP
2	276.3800	30.38	-15.49	14.89	46.00	-31.11	QP
3	446.1300	30.27	-9.83	20.44	46.00	-25.56	QP
4	628.4900	29.86	-5.11	24.75	46.00	-21.25	QP
5	860.3200	29.29	-0.42	28.87	46.00	-17.13	QP
6	965.0800	30.03	1.89	31.92	54.00	-22.08	QP

Remark:

1. Margin = Result (Result =Reading + Factor)–Limit

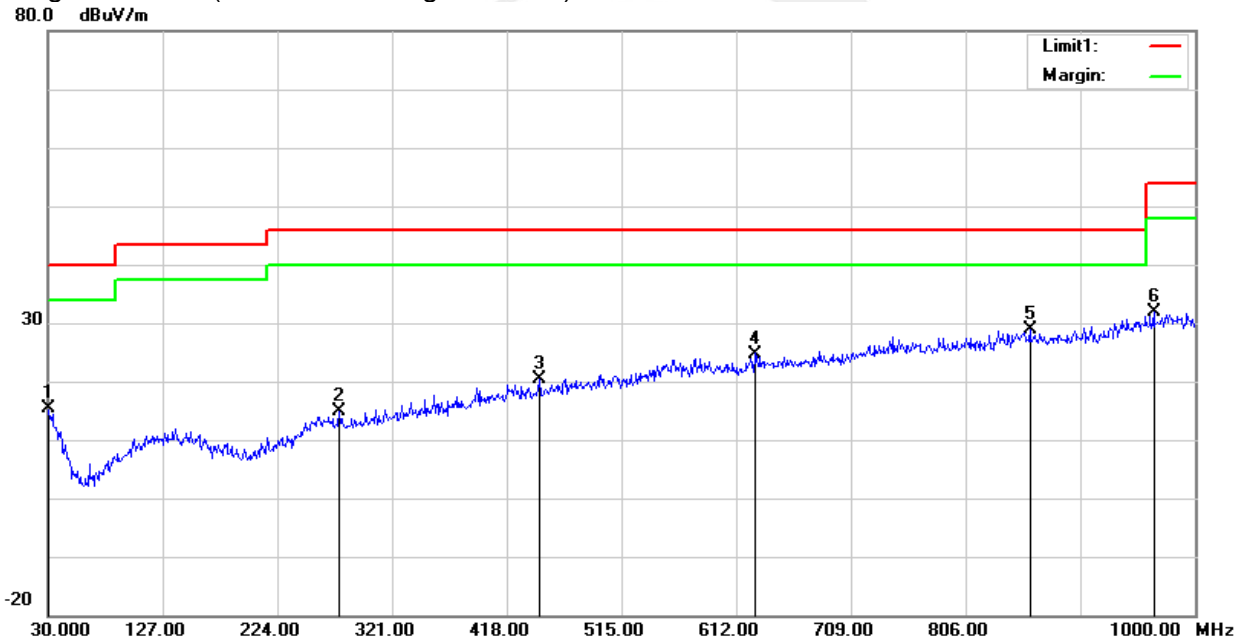



Temperature	23.4(C)	Relative Humidity:	52%RH
Test Voltage	AC 120V/60Hz	Polarization:	Vertical
Test Mode	Mode 1~6(Mode 1 worst mode)		

No.	Frequency (MHz)	Reading (dBuV)	Correct Factor(dB/m)	Result (dBuV/m)	Limit (dBuV/m)	Margin (dB)	Remark
1	31.9400	27.82	-13.86	13.96	40.00	-26.04	QP
2	256.9800	29.47	-15.13	14.34	46.00	-31.66	QP
3	471.3500	28.98	-8.95	20.03	46.00	-25.97	QP
4	561.5600	29.78	-5.51	24.27	46.00	-21.73	QP
5	860.3200	29.54	-0.42	29.12	46.00	-16.88	QP
6	978.6600	29.10	2.58	31.68	54.00	-22.32	QP

Remark:

1. Margin = Result (Result =Reading + Factor)–Limit

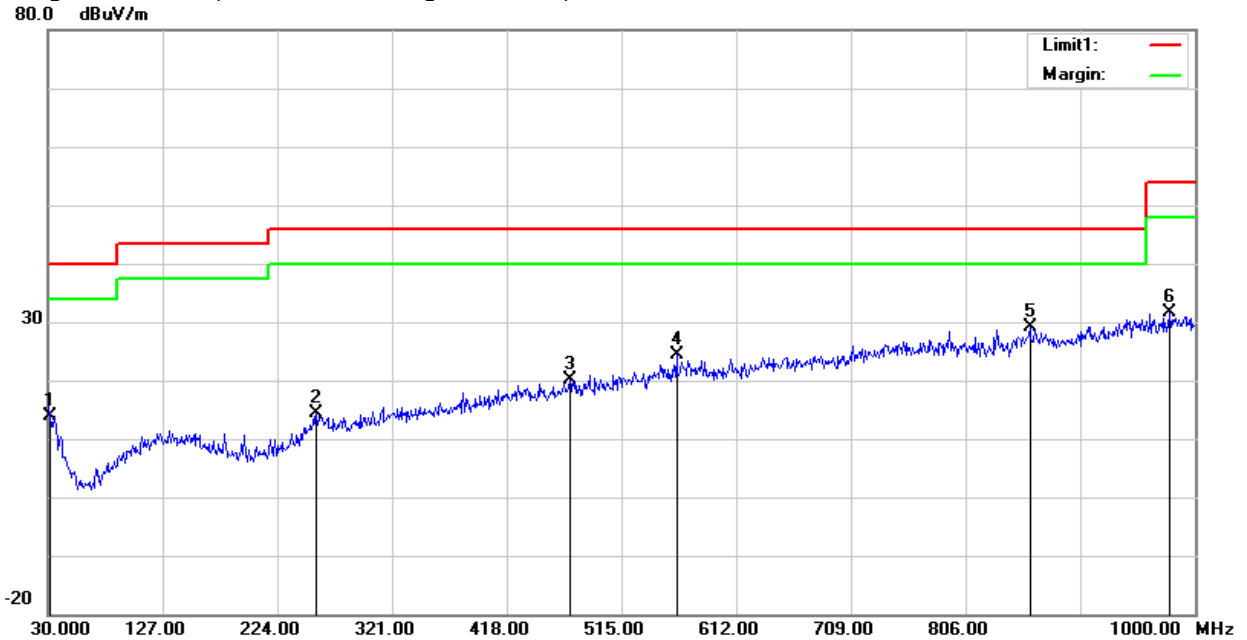



3.2.8 TEST RESULTS (Above 1000 MHz)

Band I 5150-5250MHz

Frequency (MHz)	Reading (dBuV)	Amplifier (dB)	Loss (dB)	Antenna Factor (dB/m)	Orrected Factor (dB)	Emission Level (dBuV/m)	Limit (dBuV/m)	Margin (dB)	Detector	Comment
Low Channel (802.11n20/ 5180 MHz)										
3247.98	44.16	44.70	6.70	28.20	-9.80	34.36	68.20	-33.84	Pk	Vertical
3247.98	41.30	44.70	6.70	28.20	-9.80	31.50	54.00	-22.50	AV	Vertical
3254.93	44.76	44.70	6.70	28.20	-9.80	34.96	68.20	-33.24	Pk	Horizontal
3254.93	41.15	44.70	6.70	28.20	-9.80	31.35	54.00	-22.65	AV	Horizontal
3994.54	39.13	44.20	7.90	29.70	-6.60	32.53	68.20	-35.67	Pk	Vertical
3994.54	37.14	44.20	7.90	29.70	-6.60	30.54	54.00	-23.46	AV	Vertical
3991.84	39.86	44.20	7.90	29.70	-6.60	33.26	68.20	-34.94	Pk	Horizontal
3991.84	36.04	44.20	7.90	29.70	-6.60	29.44	54.00	-24.56	AV	Horizontal
7216.64	37.37	43.50	11.40	35.50	3.40	40.77	68.20	-27.43	Pk	Vertical
7216.64	34.61	43.50	11.40	35.50	3.40	38.01	54.00	-15.99	AV	Vertical
7222.96	37.38	43.50	11.40	35.50	3.40	40.78	68.20	-27.42	Pk	Horizontal
7222.96	33.72	43.50	11.40	35.50	3.40	37.12	54.00	-16.88	AV	Horizontal
10360.36	39.55	44.50	13.80	38.80	8.10	47.65	68.20	-20.55	Pk	Vertical
10360.36	35.90	44.50	13.80	38.80	8.10	44.00	54.00	-10.00	AV	Vertical
10360.19	39.70	44.50	13.80	38.80	8.10	47.80	68.20	-20.40	Pk	Horizontal
10360.19	36.83	44.50	13.80	38.80	8.10	44.93	54.00	-9.07	AV	Horizontal
11029.93	33.85	43.60	14.30	39.50	10.20	44.05	68.20	-24.15	Pk	Vertical
11029.93	30.59	43.60	14.30	39.50	10.20	40.79	54.00	-13.21	AV	Vertical
11031.15	33.38	43.60	14.30	39.50	10.20	43.58	68.20	-24.62	Pk	Horizontal
11031.15	30.08	43.60	14.30	39.50	10.20	40.28	54.00	-13.72	AV	Horizontal
13286.38	32.14	42.60	15.90	38.90	12.20	44.34	68.20	-23.86	Pk	Vertical
13286.38	28.87	42.60	15.90	38.90	12.20	41.07	54.00	-12.93	AV	Vertical
13283.60	31.96	42.60	15.90	38.90	12.20	44.16	68.20	-24.04	Pk	Horizontal
13283.60	28.55	42.60	15.90	38.90	12.20	40.75	54.00	-13.25	AV	Horizontal
Mid Channel (802.11n20/ 5200 MHz)										
3255.43	43.89	44.70	6.70	28.20	-9.80	34.09	68.20	-34.11	Pk	Vertical
3255.43	41.05	44.70	6.70	28.20	-9.80	31.25	54.00	-22.75	AV	Vertical
3249.32	44.87	44.70	6.70	28.20	-9.80	35.07	68.20	-33.13	Pk	Horizontal
3249.32	40.96	44.70	6.70	28.20	-9.80	31.16	54.00	-22.84	AV	Horizontal
3997.29	39.24	44.20	7.90	29.70	-6.60	32.64	68.20	-35.56	Pk	Vertical
3997.29	36.14	44.20	7.90	29.70	-6.60	29.54	54.00	-24.46	AV	Vertical
3995.83	39.75	44.20	7.90	29.70	-6.60	33.15	68.20	-35.05	Pk	Horizontal
3995.83	36.44	44.20	7.90	29.70	-6.60	29.84	54.00	-24.16	AV	Horizontal
7222.14	36.67	43.50	11.40	35.50	3.40	40.07	68.20	-28.13	Pk	Vertical
7222.14	34.72	43.50	11.40	35.50	3.40	38.12	54.00	-15.88	AV	Vertical
7233.05	36.85	43.50	11.40	35.50	3.40	40.25	68.20	-27.95	Pk	Horizontal
7233.05	34.43	43.50	11.40	35.50	3.40	37.83	54.00	-16.17	AV	Horizontal
10400.16	39.03	44.50	13.80	38.80	8.10	47.13	68.20	-21.07	Pk	Vertical
10400.16	36.78	44.50	13.80	38.80	8.10	44.88	54.00	-9.12	AV	Vertical
10400.34	39.33	44.50	13.80	38.80	8.10	47.43	68.20	-20.77	Pk	Horizontal
10400.34	36.20	44.50	13.80	38.80	8.10	44.30	54.00	-9.70	AV	Horizontal
11029.10	33.74	43.60	14.30	39.50	10.20	43.94	68.20	-24.26	Pk	Vertical
11029.10	30.66	43.60	14.30	39.50	10.20	40.86	54.00	-13.14	AV	Vertical
11034.25	32.95	43.60	14.30	39.50	10.20	43.15	68.20	-25.05	Pk	Horizontal
11034.25	30.38	43.60	14.30	39.50	10.20	40.58	54.00	-13.42	AV	Horizontal
13284.62	32.20	42.60	15.90	38.90	12.20	44.40	68.20	-23.80	Pk	Vertical
13284.62	29.63	42.60	15.90	38.90	12.20	41.83	54.00	-12.17	AV	Vertical
13294.70	31.88	42.60	15.90	38.90	12.20	44.08	68.20	-24.12	Pk	Horizontal
13294.70	28.92	42.60	15.90	38.90	12.20	41.12	54.00	-12.88	AV	Horizontal



High Channel (802.11n20/ 5240 MHz)										
3253.22	44.00	44.70	6.70	28.20	-9.80	34.20	68.20	-34.00	Pk	Vertical
3253.22	40.81	44.70	6.70	28.20	-9.80	31.01	54.00	-22.99	AV	Vertical
3254.11	43.93	44.70	6.70	28.20	-9.80	34.13	68.20	-34.07	Pk	Horizontal
3254.11	41.60	44.70	6.70	28.20	-9.80	31.80	54.00	-22.20	AV	Horizontal
3989.60	39.26	44.20	7.90	29.70	-6.60	32.66	68.20	-35.54	Pk	Vertical
3989.60	36.08	44.20	7.90	29.70	-6.60	29.48	54.00	-24.52	AV	Vertical
3991.19	39.44	44.20	7.90	29.70	-6.60	32.84	68.20	-35.36	Pk	Horizontal
3991.19	36.51	44.20	7.90	29.70	-6.60	29.91	54.00	-24.09	AV	Horizontal
7220.61	36.49	43.50	11.40	35.50	3.40	39.89	68.20	-28.31	Pk	Vertical
7220.61	34.17	43.50	11.40	35.50	3.40	37.57	54.00	-16.43	AV	Vertical
7223.50	37.27	43.50	11.40	35.50	3.40	40.67	68.20	-27.53	Pk	Horizontal
7223.50	34.23	43.50	11.40	35.50	3.40	37.63	54.00	-16.37	AV	Horizontal
10480.19	39.95	44.50	13.80	38.80	8.10	48.05	68.20	-20.15	Pk	Vertical
10480.19	35.74	44.50	13.80	38.80	8.10	43.84	54.00	-10.16	AV	Vertical
10480.13	39.89	44.50	13.80	38.80	8.10	47.99	68.20	-20.21	Pk	Horizontal
10480.13	36.67	44.50	13.80	38.80	8.10	44.77	54.00	-9.23	AV	Horizontal
11027.50	32.87	43.60	14.30	39.50	10.20	43.07	68.20	-25.13	Pk	Vertical
11027.50	30.77	43.60	14.30	39.50	10.20	40.97	54.00	-13.03	AV	Vertical
11031.32	33.66	43.60	14.30	39.50	10.20	43.86	68.20	-24.34	Pk	Horizontal
11031.32	29.68	43.60	14.30	39.50	10.20	39.88	54.00	-14.12	AV	Horizontal
13292.15	32.20	42.60	15.90	38.90	12.20	44.40	68.20	-23.80	Pk	Vertical
13292.15	29.32	42.60	15.90	38.90	12.20	41.52	54.00	-12.48	AV	Vertical
13299.16	31.72	42.60	15.90	38.90	12.20	43.92	68.20	-24.28	Pk	Horizontal
13299.16	29.43	42.60	15.90	38.90	12.20	41.63	54.00	-12.37	AV	Horizontal

Remark:

1. Factor = Antenna Factor + Cable Loss – Pre-amplifier.
2. Scan with 802.11a, 802.11n (HT-20), 802.11n (HT-40) the worst case is 802.11n (HT-20).
3. The frequency emission of peak points that did not show above the forms are at least 20dB below the limit, the frequency emission is mainly from the environment noise.



Band IV(5.725-5.850) GHz

Frequency (MHz)	Reading	Amplifier	Loss	Antenna Factor	Orrected Factor	Emission Level	Limit (dBuV/m)	Margin	Detector	Comment
	(dBuV)	(dB)	(dB)	(dB/m)	(dB)	(dBuV/m)		(dB)		
Low Channel (802.11a/ 5745 MHz)										
3252.01	44.72	44.70	6.70	28.20	-9.80	34.92	68.20	-33.28	Pk	Vertical
3252.01	42.16	44.70	6.70	28.20	-9.80	32.36	54.00	-21.64	AV	Vertical
3263.42	44.68	44.70	6.70	28.20	-9.80	34.88	68.20	-33.32	Pk	Horizontal
3263.42	40.81	44.70	6.70	28.20	-9.80	31.01	54.00	-22.99	AV	Horizontal
3989.48	39.52	44.20	7.90	29.70	-6.60	32.92	68.20	-35.28	Pk	Vertical
3989.48	36.32	44.20	7.90	29.70	-6.60	29.72	54.00	-24.28	AV	Vertical
3999.64	38.79	44.20	7.90	29.70	-6.60	32.19	68.20	-36.01	Pk	Horizontal
3999.64	36.75	44.20	7.90	29.70	-6.60	30.15	54.00	-23.85	AV	Horizontal
7226.20	37.59	43.50	11.40	35.50	3.40	40.99	68.20	-27.21	Pk	Vertical
7226.20	34.45	43.50	11.40	35.50	3.40	37.85	54.00	-16.15	AV	Vertical
7231.31	37.54	43.50	11.40	35.50	3.40	40.94	68.20	-27.26	Pk	Horizontal
7231.31	34.02	43.50	11.40	35.50	3.40	37.42	54.00	-16.58	AV	Horizontal
10352.92	40.05	44.50	13.80	38.80	8.10	48.15	68.20	-20.05	Pk	Vertical
10352.92	37.14	44.50	13.80	38.80	8.10	45.24	54.00	-8.76	AV	Vertical
10346.19	38.97	44.50	13.80	38.80	8.10	47.07	68.20	-21.13	Pk	Horizontal
10346.19	35.88	44.50	13.80	38.80	8.10	43.98	54.00	-10.02	AV	Horizontal
11000.09	33.71	43.60	14.30	39.50	10.20	43.91	68.20	-24.29	Pk	Vertical
11000.09	30.48	43.60	14.30	39.50	10.20	40.68	54.00	-13.32	AV	Vertical
11000.38	33.20	43.60	14.30	39.50	10.20	43.40	68.20	-24.80	Pk	Horizontal
11000.38	29.82	43.60	14.30	39.50	10.20	40.02	54.00	-13.98	AV	Horizontal
13280.41	31.56	42.60	15.90	38.90	12.20	43.76	68.20	-24.44	Pk	Vertical
13280.41	29.22	42.60	15.90	38.90	12.20	41.42	54.00	-12.58	AV	Vertical
13292.74	32.46	42.60	15.90	38.90	12.20	44.66	68.20	-23.54	Pk	Horizontal
13292.74	29.08	42.60	15.90	38.90	12.20	41.28	54.00	-12.72	AV	Horizontal
Mid Channel (802.11a/ 5785 MHz)										
3261.46	45.01	44.70	6.70	28.20	-9.80	35.21	68.20	-32.99	Pk	Vertical
3261.46	42.18	44.70	6.70	28.20	-9.80	32.38	54.00	-21.62	AV	Vertical
3246.05	44.96	44.70	6.70	28.20	-9.80	35.16	68.20	-33.04	Pk	Horizontal
3246.05	42.12	44.70	6.70	28.20	-9.80	32.32	54.00	-21.68	AV	Horizontal
3991.77	39.49	44.20	7.90	29.70	-6.60	32.89	68.20	-35.31	Pk	Vertical
3991.77	35.71	44.20	7.90	29.70	-6.60	29.11	54.00	-24.89	AV	Vertical
3998.00	39.00	44.20	7.90	29.70	-6.60	32.40	68.20	-35.80	Pk	Horizontal
3998.00	37.04	44.20	7.90	29.70	-6.60	30.44	54.00	-23.56	AV	Horizontal
7233.47	36.78	43.50	11.40	35.50	3.40	40.18	68.20	-28.02	Pk	Vertical
7233.47	34.26	43.50	11.40	35.50	3.40	37.66	54.00	-16.34	AV	Vertical
7228.52	36.85	43.50	11.40	35.50	3.40	40.25	68.20	-27.95	Pk	Horizontal
7228.52	34.66	43.50	11.40	35.50	3.40	38.06	54.00	-15.94	AV	Horizontal
10391.48	39.46	44.50	13.80	38.80	8.10	47.56	68.20	-20.64	Pk	Vertical
10391.48	35.96	44.50	13.80	38.80	8.10	44.06	54.00	-9.94	AV	Vertical
10398.97	39.55	44.50	13.80	38.80	8.10	47.65	68.20	-20.55	Pk	Horizontal
10398.97	36.33	44.50	13.80	38.80	8.10	44.43	54.00	-9.57	AV	Horizontal
11160.38	33.26	43.60	14.30	39.50	10.20	43.46	68.20	-24.74	Pk	Vertical
11160.38	30.16	43.60	14.30	39.50	10.20	40.36	54.00	-13.64	AV	Vertical
11159.98	33.94	43.60	14.30	39.50	10.20	44.14	68.20	-24.06	Pk	Horizontal
11159.98	30.81	43.60	14.30	39.50	10.20	41.01	54.00	-12.99	AV	Horizontal
13283.24	31.78	42.60	15.90	38.90	12.20	43.98	68.20	-24.22	Pk	Vertical
13283.24	29.59	42.60	15.90	38.90	12.20	41.79	54.00	-12.21	AV	Vertical
13293.52	32.97	42.60	15.90	38.90	12.20	45.17	68.20	-23.03	Pk	Horizontal
13293.52	29.42	42.60	15.90	38.90	12.20	41.62	54.00	-12.38	AV	Horizontal



High Channel (802.11a/ 5825 MHz)										
3261.47	44.00	44.70	6.70	28.20	-9.80	34.20	68.20	-34.00	Pk	Vertical
3261.47	41.46	44.70	6.70	28.20	-9.80	31.66	54.00	-22.34	AV	Vertical
3257.37	44.00	44.70	6.70	28.20	-9.80	34.20	68.20	-34.00	Pk	Horizontal
3257.37	41.91	44.70	6.70	28.20	-9.80	32.11	54.00	-21.89	AV	Horizontal
3998.38	38.87	44.20	7.90	29.70	-6.60	32.27	68.20	-35.93	Pk	Vertical
3998.38	36.33	44.20	7.90	29.70	-6.60	29.73	54.00	-24.27	AV	Vertical
3983.64	39.95	44.20	7.90	29.70	-6.60	33.35	68.20	-34.85	Pk	Horizontal
3983.64	35.90	44.20	7.90	29.70	-6.60	29.30	54.00	-24.70	AV	Horizontal
7220.60	37.51	43.50	11.40	35.50	3.40	40.91	68.20	-27.29	Pk	Vertical
7220.60	34.84	43.50	11.40	35.50	3.40	38.24	54.00	-15.76	AV	Vertical
7225.20	37.23	43.50	11.40	35.50	3.40	40.63	68.20	-27.57	Pk	Horizontal
7225.20	34.60	43.50	11.40	35.50	3.40	38.00	54.00	-16.00	AV	Horizontal
10471.61	39.91	44.50	13.80	38.80	8.10	48.01	68.20	-20.19	Pk	Vertical
10471.61	37.09	44.50	13.80	38.80	8.10	45.19	54.00	-8.81	AV	Vertical
10461.67	39.58	44.50	13.80	38.80	8.10	47.68	68.20	-20.52	Pk	Horizontal
10461.67	36.03	44.50	13.80	38.80	8.10	44.13	54.00	-9.87	AV	Horizontal
11400.34	33.70	43.60	14.30	39.50	10.20	43.90	68.20	-24.30	Pk	Vertical
11400.34	29.70	43.60	14.30	39.50	10.20	39.90	54.00	-14.10	AV	Vertical
11399.97	32.98	43.60	14.30	39.50	10.20	43.18	68.20	-25.02	Pk	Horizontal
11399.97	30.33	43.60	14.30	39.50	10.20	40.53	54.00	-13.47	AV	Horizontal
13288.47	31.90	42.60	15.90	38.90	12.20	44.10	68.20	-24.10	Pk	Vertical
13288.47	29.46	42.60	15.90	38.90	12.20	41.66	54.00	-12.34	AV	Vertical
13288.03	32.64	42.60	15.90	38.90	12.20	44.84	68.20	-23.36	Pk	Horizontal
13288.03	29.51	42.60	15.90	38.90	12.20	41.71	54.00	-12.29	AV	Horizontal

Remark:

1. Factor = Antenna Factor + Cable Loss – Pre-amplifier.
2. Scan with 802.11a, 802.11n (HT-20), 802.11n (HT-40) the worst case is 802.11a.
3. The frequency emission of peak points that did not show above the forms are at least 20dB below the limit, the frequency emission is mainly from the environment noise.



3.2.9 Band Edge
Band I 5150-5250MHz

802.11n20 Low
Horizontal

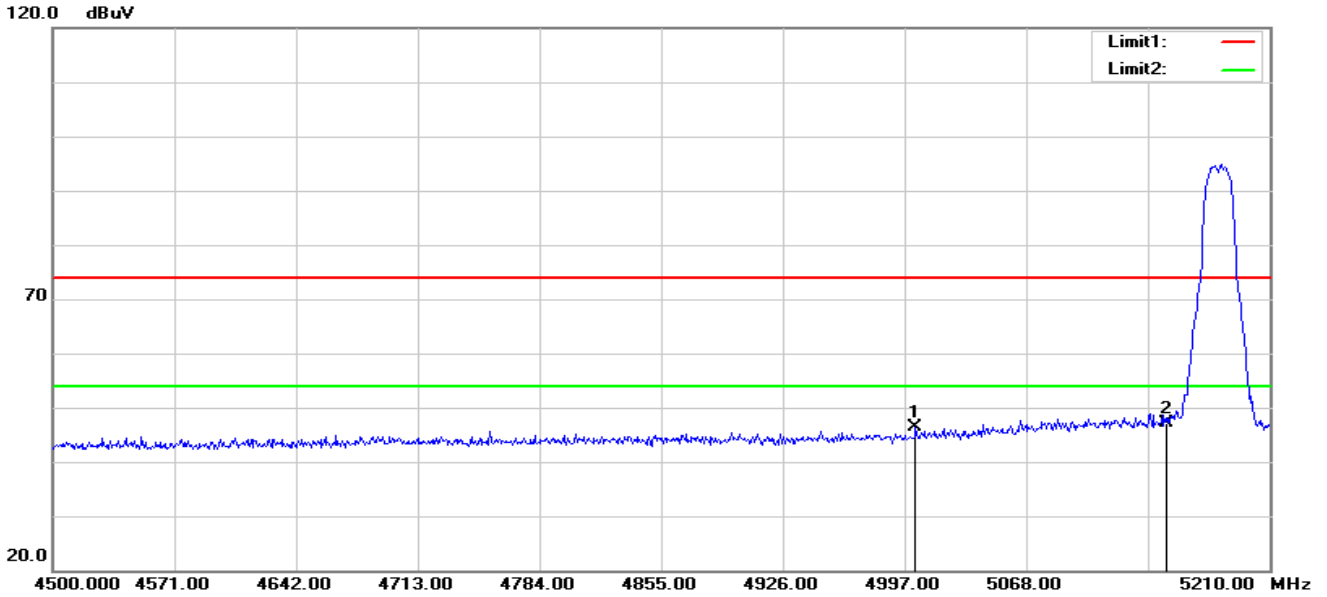

No.	Frequency (MHz)	Reading (dBuV)	Correct Factor(dB)	Result (dBuV)	Limit (dBuV)	Margin (dB)	Remark
1	5003.390	52.50	-6.18	46.32	74.00	-27.68	peak
2	5150.000	52.82	-5.73	47.09	74.00	-26.91	peak

Vertical

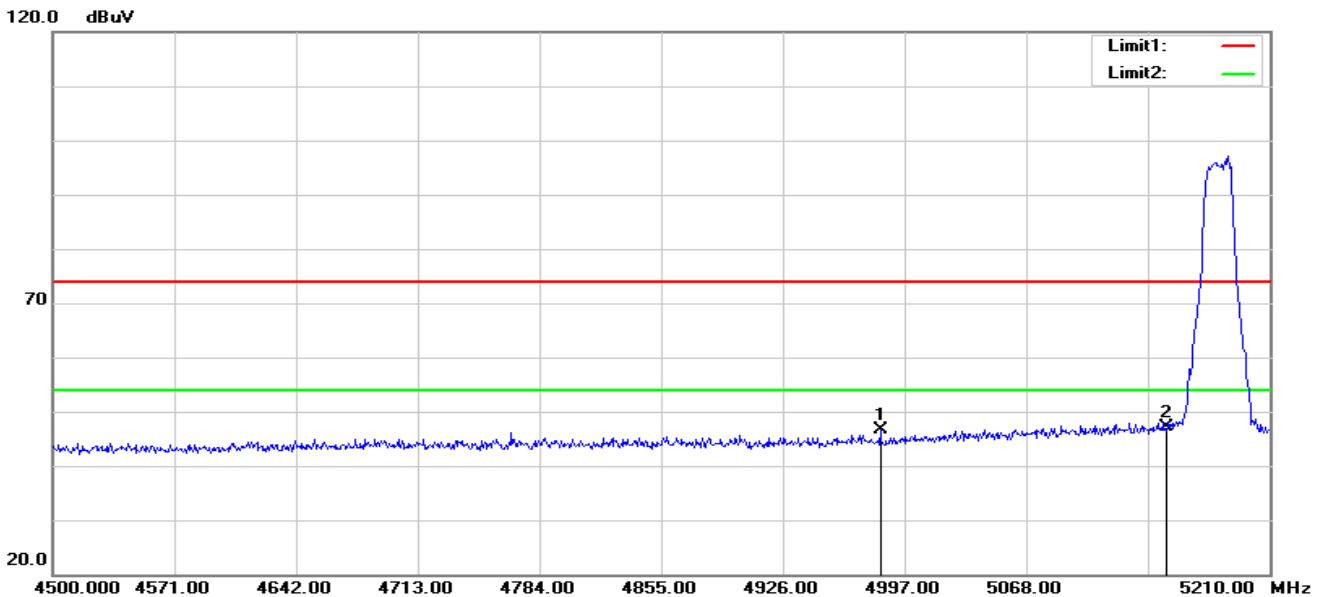

No.	Frequency (MHz)	Reading (dBuV)	Correct Factor(dB)	Result (dBuV)	Limit (dBuV)	Margin (dB)	Remark
1	4982.800	52.92	-6.30	46.62	74.00	-27.38	peak
2	5150.000	52.82	-5.73	47.09	74.00	-26.91	peak



802.11n20 High
Horizontal

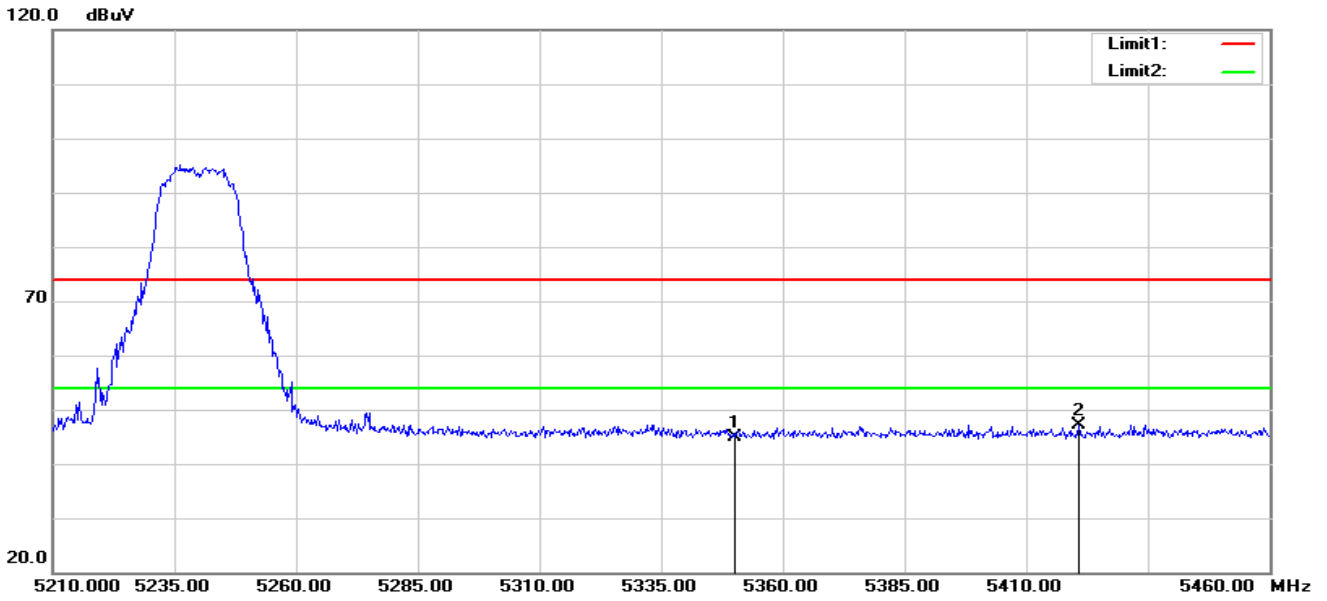

No.	Frequency (MHz)	Reading (dBuV)	Correct Factor(dB)	Result (dBuV)	Limit (dBuV)	Margin (dB)	Remark
1	5350.000	50.22	-5.23	44.99	74.00	-29.01	peak
2	5420.750	52.36	-5.20	47.16	74.00	-26.84	peak

Vertical

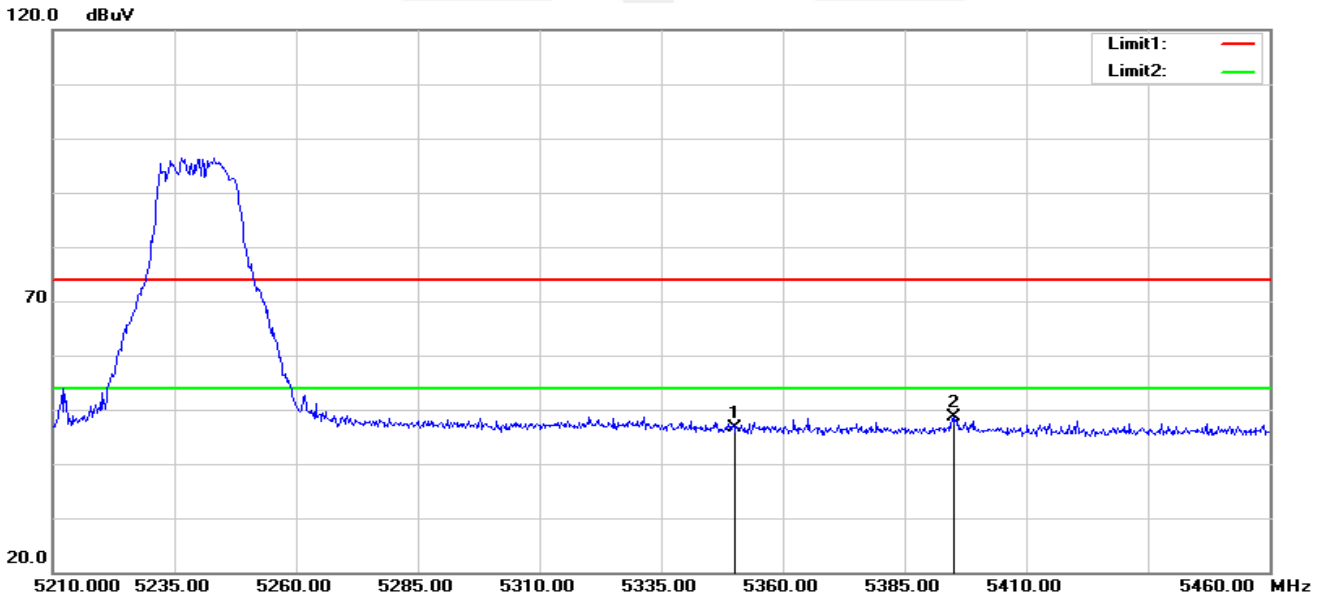

No.	Frequency (MHz)	Reading (dBuV)	Correct Factor(dB)	Result (dBuV)	Limit (dBuV)	Margin (dB)	Remark
1	5350.000	51.90	-5.23	46.67	74.00	-27.33	peak
2	5395.250	53.82	-5.24	48.58	74.00	-25.42	peak

Note: 802.11a,802.11n (HT-20),802.11n (HT-40) all has been tested, the worst case is 802.11a,only shown the worst case.

Band IV(5.725-5.85 GHz)

Note: The main frequency is too far away from the restricted band and does not require testing.

4. CONDUCTED SPURIOUS EMISSIONS AND BANDEDGE

4.1 LIMIT

Undesirable emission limits. Except as shown in paragraph (b)(7) of this section, the maximum emissions outside of the frequency bands of operation shall be attenuated in accordance with the following limits:

- (1) For transmitters operating in the 5.15-5.25 GHz band: All emissions outside of the 5.15-5.35 GHz band shall not exceed an e.i.r.p. of -27 dBm/MHz.
- (2) For transmitters operating in the 5.25-5.35 GHz band: All emissions outside of the 5.15-5.35 GHz band shall not exceed an e.i.r.p. of -27 dBm/MHz.
- (3) For transmitters operating in the 5.47-5.725 GHz band: All emissions outside of the 5.47-5.725 GHz band shall not exceed an e.i.r.p. of -27 dBm/MHz.
- (4) For transmitters operating in the 5.725-5.85 GHz band:
 - (i) All emissions shall be limited to a level of -27 dBm/MHz at 75 MHz or more above or below the band edge increasing linearly to 10 dBm/MHz at 25 MHz above or below the band edge, and from 25 MHz above or below the band edge increasing linearly to a level of 15.6 dBm/MHz at 5 MHz above or below the band edge, and from 5 MHz above or below the band edge increasing linearly to a level of 27 dBm/MHz at the band edge.

4.2 TEST PROCEDURE

Spectrum Parameter	Setting
Detector	Peak
Start/Stop Frequency	30 MHz to 10th carrier harmonic
RB / VB (emission in restricted band)	1000 KHz/3000 KHz
Trace-Mode:	Max hold

For Band edge

Spectrum Parameter	Setting
Detector	Peak
Start/Stop Frequency	Lower Band Edge: 5700 to 5725 MHz Upper Band Edge: 5850 to 5870 MHz
RB / VB (emission in restricted band)	1000 KHz/3000 KHz
Trace-Mode:	Max hold

4.3 DEVIATION FROM STANDARD

No deviation.

4.4 TEST SETUP

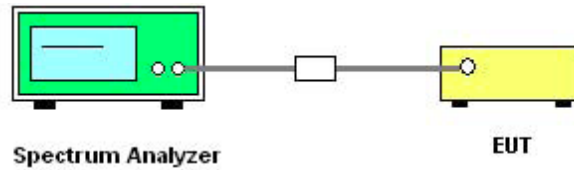

The EUT which is powered by the Battery, is coupled to the Spectrum Analyzer; the RF load attached to the EUT antenna terminal is 50Ohm; the path loss as the factor is calibrated to correct the reading.

Make the measurement with the spectrum analyzer's resolution bandwidth (RBW) = 1000 kHz. In order to make an accurate measurement, set the span greater than RBW.

4.5 EUT OPERATION CONDITIONS

The EUT tested system was configured as the statements of 2.3 Unless otherwise a special operating condition is specified in the follows during the testing.

4.6 TEST RESULTS

Data See Attachment A





5. POWER SPECTRAL DENSITY TEST

5.1 LIMIT

FCC:

1. For mobile and portable client devices in the 5.15-5.25 GHz band, , the maximum power spectral density shall not exceed 11 dBm in any 1 megahertz band. If transmitting antennas of directional gain greater than 6 dBi are used, both the maximum conducted output power and the maximum power spectral density shall be reduced by the amount in dB that the directional gain of the antenna exceeds 6 dBi.
2. For the 5.25-5.35 GHz and 5.47-5.725 GHz bands, the maximum power spectral density shall not exceed 11 dBm in any 1 megahertz band. If transmitting antennas of directional gain greater than 6 dBi are used, both the maximum conducted output power and the maximum power spectral density shall be reduced by the amount in dB that the directional gain of the antenna exceeds 6 dBi.
3. For the band 5.725-5.850 GHz, the peak power spectral density shall not exceed 30 dBm in any 500KHz band. If transmitting antenna directional gain is greater than 6 dBi, both the maximum conducted output power and the peak power spectral density shall be reduced by the amount in dB that the directional gain of the antenna exceeds 6 dBi.

IC:

1. For the 5.15-5.25 GHz, The e.i.r.p. spectral density shall not exceed 10 dBm in any 1.0 MHz band.
2. For the 5.25-5.35 GHz and 5.47-5.725 GHz bands, The power spectral density shall not exceed 11 dBm in any 1.0 MHz band.
3. The output power spectral density shall not exceed 30 dBm in any 500 kHz band. If transmitting antennas of directional gain greater than 6 dBi are used, both the maximum conducted output power and the output power spectral density shall be reduced by the amount in dB that the directional gain of the antenna exceeds 6 dBi. However, fixed point-to-point devices operating in this band may employ transmitting antennas with directional gain greater than 6 dBi without any corresponding reduction in transmitter conducted power. Fixed point-to-point operations exclude the use of point-to-multipoint systems, omnidirectional applications and multiple collocated transmitters transmitting the same information.

5.2 TEST PROCEDURE

1. The setting follows Method SA-1 of FCC KDB D02 General UNII Test Procedures New Rules v01r03.

For devices operating in the band, the rules specify a measurement bandwidth of 500 kHz. Many spectrum analyzers do not have 500 kHz RBW, thus a narrower RBW may need to be used. The rules permit the use of a RBWs less than 1 MHz, or 500 kHz, “provided that the measured power is integrated over the full reference bandwidth” to show the total power over the specified measurement bandwidth (*i.e.*, 1 MHz, or 500 kHz). If measurements are performed using a reduced resolution bandwidth (< 1 MHz, or < 500 kHz) and integrated over 1 MHz, or 500 KHz bandwidth, the following adjustments to the procedures apply:

- a) Set $RBW \geq 1/T$, where T is defined in section II.B.I.a).
- b) Set $VBW \geq 3 RBW$.
- c) If measurement bandwidth of Maximum PSD is specified in 500 kHz, add $10 \log (500\text{kHz}/RBW)$ to the measured result, whereas $RBW (< 500 \text{ kHz})$ is the reduced resolution bandwidth of the spectrum analyzer set during measurement.
- d) If measurement bandwidth of Maximum PSD is specified in 1 MHz, add $10 \log (1\text{MHz}/RBW)$ to the measured result, whereas $RBW (< 1 \text{ MHz})$ is the reduced resolution bandwidth of spectrum analyzer set during measurement.
- e) Care must be taken to ensure that the measurements are performed during a period of continuous transmission or are corrected upward for duty cycle.

Note: As a practical matter, it is recommended to use reduced RBW of 100 kHz for the sections 5.c) and 5.d) above, since $RBW=100 \text{ KHZ}$ is available on nearly all spectrum analyzers.

5.3 DEVIATION FROM STANDARD

No deviation.

5.4 TEST SETUP



5.5 EUT OPERATION CONDITIONS

The EUT tested system was configured as the statements of 2.1 Unless otherwise a special operating condition is specified in the follows during the testing.



5.6 TEST RESULTS

5150-5250MHz					
Frequency	Direct measurement Power Density (dBm)	Duty cycle factor (dB)	Final Power Density (dBm)	Limit (dBm)	Result
802.11a					
5180	-8.370	0.024	-8.346	11	PASS
5200	-8.382	0.024	-8.358	11	PASS
5240	-8.214	0.024	-8.190	11	PASS
802.11n20					
5180	-8.650	0.038	-8.612	11	PASS
5200	-8.633	0.038	-8.595	11	PASS
5240	-8.436	0.038	-8.398	11	PASS
802.11n40					
5190	-11.866	0.077	-11.789	11	PASS
5230	-11.512	0.077	-11.435	11	PASS

5725-5850MHz						
Frequency	Use RBW 510KHz direct measurement Direct measurement Power Density (dBm)	Convert to RBW 500KHz direct measurement Power Density (dBm)	Duty cycle factor (dB)	Final Power Density (dBm)	Limit (dBm)	Result
802.11a						
5745	-9.989	-10.161	0.036	-10.125	30	PASS
5785	-9.275	-9.447	0.036	-9.411	30	PASS
5825	-8.519	-8.691	0.036	-8.655	30	PASS
802.11n20						
5745	-9.827	-9.999	0.026	-9.973	30	PASS
5785	-9.436	-9.608	0.026	-9.582	30	PASS
5825	-9.008	-9.180	0.026	-9.154	30	PASS
802.11n40						
5755	-12.711	-12.883	0.077	-12.806	30	PASS
5795	-11.656	-11.828	0.077	-11.751	30	PASS



EIRP PSD

5150-5250MHz

Frequency	Power Density Total(dBm)	Antenna Gain(dBi)	EIRP Power Density Total(dBm)	Limit (dBm)	Result
802.11a					
5180	-8.370	5.000	-3.370	10	PASS
5200	-8.382	5.000	-3.382	10	PASS
5240	-8.214	5.000	-3.214	10	PASS
802.11n20					
5180	-8.650	5.000	-3.650	10	PASS
5200	-8.633	5.000	-3.633	10	PASS
5240	-8.436	5.000	-3.436	10	PASS
802.11n40					
5190	-11.866	5.000	-6.866	10	PASS
5230	-11.512	5.000	-6.512	10	PASS

Test plot see Attachment B



6. BANDWIDTH MEASUREMENT

6.1 EMISSION BANDWIDTH (EBW) 26 BANDWID PROCEDURES / LIMIT

The following procedure shall be used for measuring 26 bandwidth.

6.1.1 TEST PROCEDURE

1. The testing follows FCC KDB 789033 D02 General UNII Test Procedures New Rules v02r01
2. Set RBW = approximately 1% of the emission bandwidth.
3. Set the VBW \geq RBW.
4. Detector = Peak.
5. Trace mode = max hold.
6. Measure the maximum width of the emission that is 26 dB down from the peak of the emission. Compare this with the RBW setting of the analyzer. Readjust RBW and repeat measurement as needed until the RBW/EBW ratio is approximately 1%.

6.1.2 DEVIATION FROM STANDARD

No deviation.

6.1.3 TEST SETUP

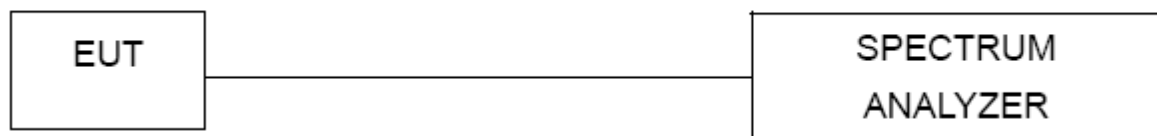

6.1.4 EUT OPERATION CONDITIONS

The EUT tested system was configured as the statements of 2.4 Unless otherwise a special operating condition is specified in the follows during the testing.

**6.1.5 TEST RESULTS**

Frequency (MHz)	26dB Bandwidth (MHz)	Pass/Fail
802.11a		
5180	21.21	Pass
5200	21.28	Pass
5240	21.23	Pass
802.11n(HT20)		
5180	21.46	Pass
5200	21.40	Pass
5240	21.52	Pass
802.11n(HT40)		
5190	40.00	Pass
5230	40.18	Pass

Frequency (MHz)	26dB Bandwidth (MHz)	Pass/Fail
802.11a		
5745	21.12	Pass
5785	21.35	Pass
5825	21.23	Pass
802.11n(HT20)		
5745	21.53	Pass
5785	21.51	Pass
5825	21.64	Pass
802.11n(HT40)		
5755	40.06	Pass
5795	40.07	Pass

Test plot see Attachment C

6.2 OCCUPIED BANDWIDTH (99%) TEST APPLIED PROCEDURES / LIMIT

The following procedure shall be used for measuring (99 %) power bandwidth.

6.2.1 TEST PROCEDURE

1. The testing follows FCC KDB 789033 D02 General UNII Test Procedures v02r01.

The following procedure shall be used for measuring (99 %) power bandwidth:

1. Set center frequency to the nominal EUT channel center frequency.
2. Set span = 1.5 times to 5.0 times the OBW.
3. Set RBW = 1 % to 5 % of the OBW
4. Set VBW $\geq 3 \cdot$ RBW
5. Video averaging is not permitted. Where practical, a sample detection and single sweep mode shall be used. Otherwise, peak detection and max hold mode (until the trace stabilizes) shall be used.
6. Use the 99 % power bandwidth function of the instrument (if available).
7. If the instrument does not have a 99 % power bandwidth function, the trace data points are recovered and directly summed in power units. The recovered amplitude data points, beginning at the lowest frequency, are placed in a running sum until 0.5 % of the total is reached; that frequency is recorded as the lower frequency. The process is repeated until 99.5 % of the total is reached; that frequency is recorded as the upper frequency. The 99% occupied bandwidth is the difference between these two frequencies.

6.2.2 DEVIATION FROM STANDARD

No deviation.

6.2.3 TEST SETUP

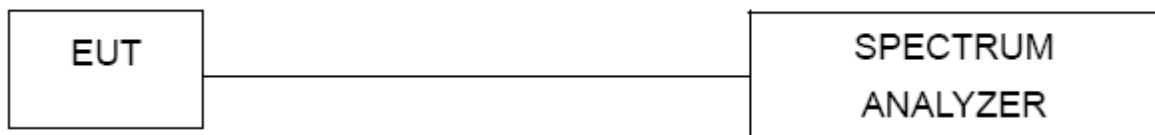

6.2.4 EUT OPERATION CONDITIONS

The EUT tested system was configured as the statements of 2.4 Unless otherwise a special operating condition is specified in the follows during the testing.

**6.2.5 TEST RESULTS**

Frequency (MHz)	99% Bandwidth (MHz)	Pass/Fail
802.11a		
5180	16.713	Pass
5200	16.702	Pass
5240	16.693	Pass
802.11n(HT20)		
5180	17.848	Pass
5200	17.835	Pass
5240	17.844	Pass
802.11n(HT40)		
5190	36.300	Pass
5230	36.288	Pass

Frequency (MHz)	99% Bandwidth (MHz)	Pass/Fail
802.11a		
5745	16.709	Pass
5785	16.720	Pass
5825	16.721	Pass
802.11n(HT20)		
5745	17.871	Pass
5785	17.850	Pass
5825	17.837	Pass
802.11n(HT40)		
5755	36.320	Pass
5795	36.335	Pass

Test plot See Attachment C

6.3 MINIMUM EMISSION BANDWIDTH(6 DB) PROCEDURES / LIMIT

Section 15.407(e) specifies the minimum 6 dB emission bandwidth of at least 500 KHz for the band 5.725-5.85 GHz. The following procedure shall be used for measuring this bandwidth:

6.3.1 TEST PROCEDURE

1. The testing follows FCC KDB 789033 D02 General UNII Test Procedures v02r01.
 - a) Set RBW = 100 kHz.
 - b) Set the video bandwidth (VBW) $\geq 3 \times$ RBW.
 - c) Detector = Peak.
 - d) Trace mode = max hold.
 - e) Sweep = auto couple.
 - f) Allow the trace to stabilize.
 - g) Measure the maximum width of the emission that is constrained by the frequencies associated with the two outermost amplitude points (upper and lower frequencies) that are attenuated by 6 dB relative to the maximum level measured in the fundamental emission.

6.3.2 DEVIATION FROM STANDARD

No deviation.

6.3.3 TEST SETUP

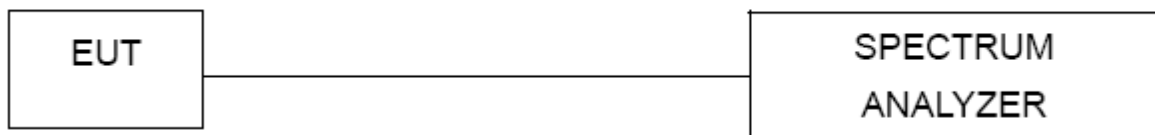

6.3.4 EUT OPERATION CONDITIONS

The EUT tested system was configured as the statements of 2.4 Unless otherwise a special operating condition is specified in the follows during the testing.

**6.3.5 TEST RESULTS**

Frequency (MHz)	6dB Bandwidth (MHz)	Pass/Fail
802.11a		
5745	16.37	Pass
5785	16.36	Pass
5825	16.38	Pass
802.11n(HT20)		
5745	17.60	Pass
5785	17.61	Pass
5825	17.61	Pass
802.11n(HT40)		
5755	36.37	Pass
5795	36.38	Pass

Test plot see Attachment D





7. MAXIMUM CONDUCTED OUTPUT POWER

7.1 LIMIT

FCC:

For mobile and portable client devices in the 5.15-5.25 GHz band, the maximum conducted output power over the frequency band of operation shall not exceed 250 mW provided the maximum antenna gain does not exceed 6 dBi. If transmitting antennas of directional gain greater than 6 dBi are used, both the maximum conducted output power and the maximum power spectral density shall be reduced by the amount in dB that the directional gain of the antenna exceeds 6 dBi.

For the 5.25-5.35 GHz and 5.47-5.725 GHz bands, the maximum conducted output power over the frequency bands of operation shall not exceed the lesser of 250 mW or $11 \text{ dBm} + 10 \log B$, where B is the 26 dB emission bandwidth in megahertz, if transmitting antennas of directional gain greater than 6 dBi are used.

For the band 5.725-5.85 GHz, the maximum conducted output power over the frequency band of operation shall not exceed 1 W. If transmitting antennas of directional gain greater than 6 dBi are used.

FCC Part15 (15.407) , Subpart E				
Section	Test Item	Limit	Frequency Range (MHz)	Result
15.407(a) (1) (iv)	Peak Output Power	0.25 watt	5150-5250	PASS
		The lesser of 250 mW or $11 \text{ dBm} + 10 \log (26 \text{ dB emission bandwidth})$	5250-5350 5470-5725	
15.407(a) (3)		1 watt	5725-5825	

IC:

For devices in the 5.15-5.25 GHz band, the maximum e.i.r.p. shall not exceed 200 mW or $10 + 10 \log_{10} B$, dBm, whichever power is less. B is the 99% emission bandwidth in megahertz.

For the 5.25-5.35 GHz and 5.47-5.725 GHz bands, The maximum conducted output power shall not exceed 250 mW or $11 + 10 \log_{10} B$, dBm, whichever is less. The power spectral density shall not exceed 11 dBm in any 1.0 MHz band.

The maximum conducted output power shall not exceed 1 W. If transmitting antennas of directional gain greater than 6 dBi are used, both the maximum conducted output power and the output power spectral density shall be reduced by the amount in dB that the directional gain of the antenna exceeds 6 dBi. However, fixed point-to-point devices operating in this band may employ transmitting antennas with directional gain greater than 6 dBi without any corresponding reduction in transmitter conducted power. Fixed point-to-point operations exclude the use of point-to-multipoint systems, omnidirectional applications and multiple collocated transmitters transmitting the same information.

RSS-247 Issue 2, February 2017				
Section	Test Item	Limit	Frequency Range (MHz)	Result
6.2.1.1	Peak Output Power	200 mW or $10 + 10 \log_{10} B$, dBm, whichever power is less. B is the 99% emission bandwidth in megahertz	5150-5250	PASS
6.2.2.1 6.2.3.1		The lesser of 250 mW or $11 \text{ dBm} + 10 \log (26 \text{ dB emission bandwidth})$	5250-5350 5470-5725	
6.2.4.1		1 watt	5725-5825	

7.2 TEST PROCEDURE

The EUT was directly connected to the Power Sensor&PC

7.3 DEVIATION FROM STANDARD

No deviation.

7.4 TEST SETUP

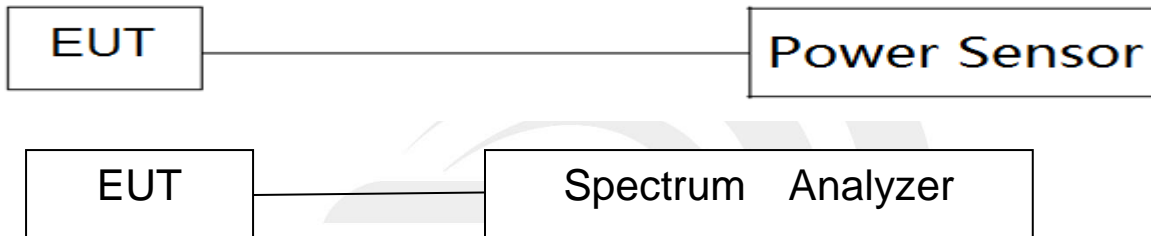

7.5 EUT OPERATION CONDITIONS

The EUT tested system was configured as the statements of 5 Unless otherwise a special operating condition is specified in the follows during the testing.



7.6 TEST RESULTS

Note:

1. For mobile and portable client devices in the 5.15-5.25 GHz band, the maximum conducted output power over the frequency band of operation shall not exceed the lesser of 0.25 W.
2. For mobile and portable client devices in the 5.25-5.35 GHz band, the maximum conducted output power over the frequency band of operation shall not exceed the lesser of 0.25 W.
3. For mobile and portable client devices in the 5.47-5.725 GHz band, the maximum conducted output power over the frequency band of operation shall not exceed the lesser of 0.25 W.
4. For the band 5.745-5.850 GHz, the maximum conducted output power over the frequency band of operation shall not exceed the lesser of 1 W

Band I (5.15-5.25GHz)					
Test Channel	Frequency (MHz)	Direct measurement AV Power (dBm)	Duty cycle factor (dB)	Final AV Power (dBm)	LIMIT (dBm)
802.11a					
36	5180	2.73	0.024	2.75	23.98
40	5200	2.94	0.024	2.96	23.98
48	5240	3.19	0.024	3.21	23.98
802.11n(HT20)					
36	5180	2.63	0.038	2.67	23.98
40	5200	2.89	0.038	2.93	23.98
48	5240	3.21	0.038	3.25	23.98
802.11n(HT40)					
38	5190	2.45	0.077	2.53	23.98
46	5230	2.91	0.077	2.99	23.98

Band IV (5.725-5.85GHz)					
Test Channel	Frequency (MHz)	Direct measurement AV Power (dBm)	Duty cycle factor (dB)	Final AV Power (dBm)	LIMIT (dBm)
802.11a					
149	5745	1.16	0.036	1.20	30
157	5785	1.39	0.036	1.43	30
165	5825	1.91	0.036	1.95	30
802.11n(HT20)					
149	5745	0.99	0.026	1.02	30
157	5785	1.30	0.026	1.33	30
165	5825	1.77	0.026	1.80	30
802.11n(HT40)					
151	5755	1.14	0.077	1.22	30
159	5795	1.44	0.077	1.52	30

EIRP Power EIRP Power

EIRP Power

Band I (5.15-5.25GHz)					
Test Channel	Frequency (MHz)	AV Power (dBm)	Antenna Gain(dBi)	EIRP Power(dBm)	LIMIT (dBm)
802.11a					
36	5180	2.73	5.00	7.73	23.01
40	5200	2.94	5.00	7.94	23.01
48	5240	3.19	5.00	8.19	23.01
802.11n(HT20)					
36	5180	2.63	5.00	7.63	23.01
40	5200	2.89	5.00	7.89	23.01
48	5240	3.21	5.00	8.21	23.01
802.11n(HT40)					
38	5190	2.45	5.00	7.45	23.01
46	5230	2.91	5.00	7.91	23.01





Duty cycle

Band1				
Mode	Ton(ms)	Tp(ms)	Duty cycle(%)	Duty factor(dB)
a	1.444	1.452	99.45%	0.024
n20	1.348	1.360	99.12%	0.038
n40	0.674	0.686	98.25%	0.077
Band4				
Mode	Ton(ms)	Tp(ms)	Duty cycle(%)	Duty factor(dB)
a	1.440	1.452	99.17%	0.036
n20	1.348	1.356	99.41%	0.026
n40	0.670	0.682	98.24%	0.077





Band 1-a20



Band 1-n20



Band 1-n40



Band 4-a20



Band 4-n20



Band 4-n40



8. AUTOMATICALLY DISCONTINUE TRANSMISSION

8.1 LIMIT OF AUTOMATICALLY DISCONTINUE TRANSMISSION

The device shall automatically discontinue transmission in case of either absence of information to transmit or operational failure. These provisions are not intended to preclude the transmission of control or signaling information or the use of repetitive codes used by certain digital technologies to complete frame or burst intervals. Applicants shall include in their application for equipment authorization to describe how this requirement is met.

8.2 TEST RESULT OF AUTOMATICALLY DISCONTINUE TRANSMISSION

During no any information transmission, the EUT can automatically discontinue transmission and become standby mode for power saving. The EUT can detect the controlling signal of ACK message transmitting from remote device and verify whether it shall resend or discontinue transmission.





9. ANTENNA REQUIREMENT

9.1 STANDARD REQUIREMENT

15.203&RSS GEN requirement: For intentional device, according to 15.203&RSS GEN: an intentional radiator shall be designed to ensure that no antenna other than that furnished by the responsible party shall be used with the device.

9.2 EUT ANTENNA

The EUT antenna is PCB Antenna. It comply with the standard requirement.





10. FREQUENCY STABILITY

10.1 LIMITS OF FREQUENCY STABILITY MEASUREMENT

The frequency tolerance of the carrier signal shall be maintained within +/-0.02% of the operating frequency over a temperature variation of -30 degrees to 50 degrees C at normal supply voltage, and for a variation in primary supply voltage from 85% to 115% of the rated supply voltage at a temperature of 20 degrees.

10.2 TEST PROCEDURE

1. The EUT was placed inside the environmental test chamber and powered by nominal DC voltage.
2. Turn the EUT on and couple its output to spectrum analyzer.
3. Turn the EUT off and set the chamber to the highest temperature specified.
4. Allow sufficient time (approximately 30 min) for the temperature of the chamber to stabilize, turn the EUT on and measure the operating frequency after 2, 5, and 10 minutes.
5. Repeat step 2 and 3 with the temperature chamber set to the lowest temperature.
6. The test chamber was allowed to stabilize at +20 degree C for a minimum of 30 minutes. The supply voltage was then adjusted on the EUT from 85% to 115% and the frequency record.

10.3 TEST RESULT

Channel 40 (5200MHz)

Voltage vs. Frequency Stability

Voltage(V)	Measurement Frequency(MHz)
138	5200.0032
120	5200.0023
102	5200.0027
Max.Deviation(MHz)	0.0032
Max.Deviation(ppm)	0.62

Rated working voltage: AC 120V/60Hz

Temperature vs. Frequency Stability

Temperature(°C)	Measurement Frequency(MHz)
-30	5200.0028
-20	5200.0025
-10	5200.0022
0	5200.0021
10	5200.0019
20	5200.0023
30	5200.0020
40	5200.0028
50	5200.0022
Max.Deviation(MHz)	0.0028
Max.Deviation(ppm)	0.54



Channel 157 (5785MHz)

Voltage vs. Frequency Stability

Voltage(V)	Measurement Frequency(MHz)
138	5785.0039
120	5785.0037
102	5785.0032
Max.Deviation(MHz)	0.0039
Max.Deviation(ppm)	0.67

Rated working voltage: AC 120V/60Hz

Temperature vs. Frequency Stability

Temperature(°C)	Measurement Frequency(MHz)
-30	5785.0031
-20	5785.0030
-10	5785.0031
0	5785.0024
10	5785.0023
20	5785.0029
30	5785.0023
40	5785.0021
50	5785.0022
Max.Deviation(MHz)	0.0031
Max.Deviation(ppm)	0.54



APPENDIX - PHOTOS OF TEST SETUP

Note: See test photos in setup photo document for the actual connections between Product and support equipment.

*****END OF THE REPORT*****

