

10.5. PROCESSING GAIN

CUSTOMER PROVIDED PROCESSING GAIN.

PROCESSING GAIN MEASUREMENT

1.1 Measurement Setup

Figure 1 shows the setup for measuring the processing gain of EzyLINK-E. A Transmitting Computer A and a Receiving Computer B are used to execute a Bit Error Rate (BER) Testing Computer Program. The BER is determined by repetitively transmitting a testing data file from Computer A to Computer B. At Computer B the received data file is compared with a pre-stored version of the testing data file to compute the bit error rate. An HP 8648C Signal Generator is used to generate interference or jamming signal.

Data signal from the Transmitting Computer is sent to the Transmitting EzyLINK-E unit for modulation. It is then combined with the interference signal from the Signal Generator through a equal power (3 dB) combiner. The combined signal is fed into a Receiving EzyLINK-E, the Device Under Test (DUT), for demodulation, and the demodulated signal is sent into the Receiving Computer for Bit Error Rate computation.

1.2 Measurement Procedure

The data signal level at the input of the Receiving EzyLINK-E, point P in Figure 1, is determined. With Attenuator A set at 60 dB attenuation, the data signal level at point P is measured to be -35 dBm.

Then the Signal Generator is set at a certain CW frequency between 2434 MHz and 2450 MHz. The interference level at the input of the Receiving EzyLINK-E, the DUT, can be varied by adjusting the output level of the Signal Generator.

The measurement of processing gain is carried out by adjusting the output level of the Signal Generator such that the Bit Error Rate is maintained at no higher than 10^{-5} . The interference level at the input of the DUT, the point P, is then measured. In the EzyLINK-E receiving chain a Surface Acoustic Wave (SAW)IF filter which has a nominal 3-dB bandwidth of ± 7.5 MHz centered at 374 MHz (see Fig. 2) is used. Jamming signals outside the 2442 ± 7.5 MHz frequency band will be heavily attenuated. The measurement is performed from 2434 MHz to 2450 MHz at 50 KHz interval. The measured interference power level at point P with $BER \leq 10^{-5}$ at each frequency is shown in the following:

Freq. (MHz)	Jammer Power(dBm)	J/S (dB)	Freq. (MHz)	Jammer Power(dBm)	J/S (dB)	Freq. (MHz)	Jammer Power(dBm)	J/S (dB)	Freq. (MHz)	Jammer Power(dBm)	J/S (dB)
2434	-39.7	-4.7	2436	-40.2	-5.2	2438	-40.1	-5.1	2440	-40.2	-5.2
2434.05	-39.6	-4.6	2436.05	-40.4	-5.4	2438.05	-40.2	-5.2	2440.05	-40.1	-5.1
2434.1	-39.7	-4.7	2436.1	-40.3	-5.3	2438.1	-40.2	-5.2	2440.1	-40.2	-5.2
2434.15	-39.7	-4.7	2436.15	-40.2	-5.2	2438.15	-40.2	-5.2	2440.15	-40.3	-5.3
2434.2	-39.8	-4.8	2436.2	-40.1	-5.1	2438.2	-40.2	-5.2	2440.2	-40.3	-5.3
2434.25	-39.8	-4.8	2436.25	-40.1	-5.1	2438.25	-40.1	-5.1	2440.25	-40.2	-5.2
2434.3	-39.8	-4.8	2436.3	-40.1	-5.1	2438.3	-40.2	-5.2	2440.3	-40.3	-5.3
2434.35	-39.4	-4.4	2436.35	-40.3	-5.3	2438.35	-40.3	-5.3	2440.35	-40.3	-5.3
2434.4	-39.9	-4.9	2436.4	-40.2	-5.2	2438.4	-40.3	-5.3	2440.4	-40.2	-5.2
2434.45	-39.8	-4.8	2436.45	-40.1	-5.1	2438.45	-40.2	-5.2	2440.45	-40.2	-5.2
2434.5	-39.9	-4.9	2436.5	-40.2	-5.2	2438.5	-40.1	-5.1	2440.5	-40.3	-5.3
2434.55	-39.9	-4.9	2436.55	-40.2	-5.2	2438.55	-40.3	-5.3	2440.55	-40.2	-5.2
2434.6	-39.8	-4.8	2436.6	-40.4	-5.4	2438.6	-40.1	-5.1	2440.6	-40.2	-5.2
2434.65	-39.7	-4.7	2436.65	-40	-5	2438.65	-40.1	-5.1	2440.65	-40.3	-5.3
2434.7	-40	-5	2436.7	-40.1	-5.1	2438.7	-40.2	-5.2	2440.7	-40.3	-5.3
2434.75	-40.1	-5.1	2436.75	-40	-5	2438.75	-40.2	-5.2	2440.75	-40.2	-5.2
2434.8	-40.2	-5.2	2436.8	-39.9	-4.9	2438.8	-40	-5	2440.8	-40.1	-5.1
2434.85	-40.2	-5.2	2436.85	-39.9	-4.9	2438.85	-40.1	-5.1	2440.85	-40.2	-5.2
2434.9	-40.3	-5.3	2436.9	-39.9	-4.9	2438.9	-40	-5	2440.9	-40.4	-5.4
2434.95	-40.4	-5.4	2436.95	-40.1	-5.1	2438.95	-40	-5	2440.95	-40.3	-5.3
2435	-40.5	-5.5	2437	-40	-5	2439	-40.2	-5.2	2441	-40.4	-5.4
2435.05	-40.5	-5.5	2437.05	-40	-5	2439.05	-40.1	-5.1	2441.05	-40.4	-5.4
2435.1	-40.4	-5.4	2437.1	-39.9	-4.9	2439.1	-40.2	-5.2	2441.1	-40.5	-5.5
2435.15	-40.5	-5.5	2437.15	-40	-5	2439.15	-40.1	-5.1	2441.15	-40.5	-5.5
2435.2	-40.4	-5.4	2437.2	-40.1	-5.1	2439.2	-40.1	-5.1	2441.2	-40.6	-5.6
2435.25	-40.3	-5.3	2437.25	-40	-5	2439.25	-40.2	-5.2	2441.25	-40.8	-5.8
2435.3	-40.4	-5.4	2437.3	-39.9	-4.9	2439.3	-40.3	-5.3	2441.3	-41.1	-6.1
2435.35	-40.3	-5.3	2437.35	-40	-5	2439.35	-40.3	-5.3	2441.35	-41.5	-6.5
2435.4	-40.4	-5.4	2437.4	-40.1	-5.1	2439.4	-40.2	-5.2	2441.4	-42.1	-7.1
2435.45	-40.4	-5.4	2437.45	-40.2	-5.2	2439.45	-40.1	-5.1	2441.45	-42.2	-7.2
2435.5	-40.3	-5.3	2437.5	-40.2	-5.2	2439.5	-40	-5	2441.5	-42.4	-7.4
2435.55	-40.3	-5.3	2437.55	-40.1	-5.1	2439.55	-40.1	-5.1	2441.55	-42.7	-7.7
2435.6	-40.4	-5.4	2437.6	-40.1	-5.1	2439.6	-40.1	-5.1	2441.6	-43	-8
2435.65	-40.4	-5.4	2437.65	-40.2	-5.2	2439.65	-40.3	-5.3	2441.65	-43.9	-8.9
2435.7	-40.5	-5.5	2437.7	-40.2	-5.2	2439.7	-40.3	-5.3	2441.7	-43.3	-8.3
2435.75	-40.5	-5.5	2437.75	-40.3	-5.3	2439.75	-40.3	-5.3	2441.75	-43.6	-8.6
2435.8	-40.5	-5.5	2437.8	-40.3	-5.3	2439.8	-40.2	-5.2	2441.8	-43.8	-8.8
2435.85	-40.4	-5.4	2437.85	-40.3	-5.3	2439.85	-40.2	-5.2	2441.85	-43.8	-8.8
2435.9	-40.3	-5.3	2437.9	-40.3	-5.3	2439.9	-40.1	-5.1	2441.9	-43.9	-8.9
2435.95	-40.5	-5.5	2437.95	-40.4	-5.4	2439.95	-40.2	-5.2	2441.95	-43.1	-8.1

Freq. (MHz)	Jammer Power(dBm)	J/S (dB)	Freq. (MHz)	Jammer Power(dBm)	J/S (dB)	Freq. (MHz)	Jammer Power(dBm)	J/S (dB)	Freq. (MHz)	Jammer Power(dBm)	J/S (dB)
2442	-43.1	-8.1	2444	-40.4	-5.4	2446	-39.9	-4.9	2448	-39.9	-4.9
2442.05	-43.6	-8.6	2444.05	-40.1	-5.1	2446.05	-39.6	-4.6	2448.05	-39.7	-4.7
2442.1	-43.5	-8.5	2444.1	-40.2	-5.2	2446.1	-39.7	-4.7	2448.1	-39.7	-4.7
2442.15	-43.3	-8.3	2444.15	-40.3	-5.3	2446.15	-39.7	-4.7	2448.15	-39.8	-4.8
2442.2	-43.7	-8.7	2444.2	-40.2	-5.2	2446.2	-39.6	-4.6	2448.2	-39.9	-4.9
2442.25	-43	-8	2444.25	-40.3	-5.3	2446.25	-39.8	-4.8	2448.25	-39.7	-4.7
2442.3	-42.9	-7.9	2444.3	-40.2	-5.2	2446.3	-39.7	-4.7	2448.3	-39.8	-4.8
2442.35	-42.7	-7.7	2444.35	-40.4	-5.4	2446.35	-39.7	-4.7	2448.35	-40	-5
2442.4	-42.7	-7.7	2444.4	-40.1	-5.1	2446.4	-39.9	-4.9	2448.4	-40.1	-5.1
2442.45	-42.6	-7.6	2444.45	-40.3	-5.3	2446.45	-40	-5	2448.45	-40.1	-5.1
2442.5	-42.5	-7.5	2444.5	-40.4	-5.4	2446.5	-40	-5	2448.5	-40	-5
2442.55	-42.3	-7.3	2444.55	-40.3	-5.3	2446.55	-40.1	-5.1	2448.55	-40	-5
2442.6	-42.1	-7.1	2444.6	-40.2	-5.2	2446.6	-40.1	-5.1	2448.6	-39.9	-4.9
2442.65	-41.9	-6.9	2444.65	-40.2	-5.2	2446.65	-40.1	-5.1	2448.65	-39.9	-4.9
2442.7	-41.8	-6.8	2444.7	-40.2	-5.2	2446.7	-40.2	-5.2	2448.7	-39.8	-4.8
2442.75	-41.6	-6.6	2444.75	-40.1	-5.1	2446.75	-40.1	-5.1	2448.75	-39.9	-4.9
2442.8	-41.5	-6.5	2444.8	-40.2	-5.2	2446.8	-40.1	-5.1	2448.8	-39.8	-4.8
2442.85	-41.3	-6.3	2444.85	-40.2	-5.2	2446.85	-40.2	-5.2	2448.85	-39.9	-4.9
2442.9	-41.1	-6.1	2444.9	-40	-5	2446.9	-40.3	-5.3	2448.9	-39.9	-4.9
2442.95	-40.8	-5.8	2444.95	-39.9	-4.9	2446.95	-40.3	-5.3	2448.95	-40	-5
2443	-40.7	-5.7	2445	-39.9	-4.9	2447	-40.4	-5.4	2449	-40.1	-5.1
2443.05	-40.6	-5.6	2445.05	-39.9	-4.9	2447.05	-40.4	-5.4	2449.05	-40	-5
2443.1	-40.5	-5.5	2445.1	-39.9	-4.9	2447.1	-40.4	-5.4	2449.1	-40.1	-5.1
2443.15	-40.3	-5.3	2445.15	-39.9	-4.9	2447.15	-40.4	-5.4	2449.15	-40.1	-5.1
2443.2	-40.2	-5.2	2445.2	-39.9	-4.9	2447.2	-40.3	-5.3	2449.2	-40.2	-5.2
2443.25	-40.2	-5.2	2445.25	-39.8	-4.8	2447.25	-40.3	-5.3	2449.25	-40.2	-5.2
2443.3	-40.1	-5.1	2445.3	-39.8	-4.8	2447.3	-40.3	-5.3	2449.3	-40.1	-5.1
2443.35	-40.1	-5.1	2445.35	-39.8	-4.8	2447.35	-40.2	-5.2	2449.35	-40.2	-5.2
2443.4	-40	-5	2445.4	-39.8	-4.8	2447.4	-40.2	-5.2	2449.4	-40.1	-5.1
2443.45	-40	-5	2445.45	-39.8	-4.8	2447.45	-40.2	-5.2	2449.45	-40.2	-5.2
2443.5	-40	-5	2445.5	-39.7	-4.7	2447.5	-40.1	-5.1	2449.5	-40	-5
2443.55	-40.1	-5.1	2445.55	-39.7	-4.7	2447.55	-40.2	-5.2	2449.55	-40	-5
2443.6	-40.1	-5.1	2445.6	-39.7	-4.7	2447.6	-40.1	-5.1	2449.6	-40.1	-5.1
2443.65	-40	-5	2445.65	-39.7	-4.7	2447.65	-40	-5	2449.65	-40.2	-5.2
2443.7	-39.9	-4.9	2445.7	-39.7	-4.7	2447.7	-40	-5	2449.7	-40.2	-5.2
2443.75	-39.9	-4.9	2445.75	-39.7	-4.7	2447.75	-39.8	-4.8	2449.75	-40.2	-5.2
2443.8	-40	-5	2445.8	-39.7	-4.7	2447.8	-39.9	-4.9	2449.8	-40.1	-5.1
2443.85	-40.1	-5.1	2445.85	-39.7	-4.7	2447.85	-39.8	-4.8	2449.85	-40.1	-5.1
2443.9	-40	-5	2445.9	-39.6	-4.6	2447.9	-39.7	-4.7	2449.9	-40	-5
2443.95	-40.2	-5.2	2445.95	-39.6	-4.6	2447.95	-39.9	-4.9	2449.95	-40	-5

Freq. (MHz)	Jammer Power(dBm)	J/S (dB)
2450	-40.2	-5.2

1.3 Determination of Processing Gain

Let the required theoretical signal to noise ratio for achieving a certain BER, say 10^{-5} , in a non-spread-spectrum receiver be SNRN and that for achieving the same BER in a spread-spectrum receiver be SNRS, the processing gain G_p achieved by this spread-spectrum receiver can be computed using the following formula:

$$G_p = \text{SNRN} + L_s - \text{SNRS (in dB)},$$

where L_s is the system loss due to the difference between a practical system and the ideal system such as the non-ideal filter characteristic.

EzyLINK-E uses DQPSK CCK modulation scheme that converts each 8-bit symbol into one of 256 complex code words of 8-bit chip sequences and transmits each sequence through the I and the Q channels. It is known that the theoretical signal to noise ratio required to achieve a 10^{-5} BER for such a DQPSK receiver with CCK modulation is 17 dB^[1]. The system loss L_s for EzyLINK-E is estimated to be approximately 2 dB.

The signal to noise ratio required by EzyLINK-E in the presence of a CW jamming signal to achieved a $\text{BER} \leq 10^{-5}$ can be computed by the measured data listed in the preceding section. The data signal level at the input of the DUT is -35 dBm. The lowest interference power level for maintaining a BER of 10^{-5} , after the worst 20% data points being discarded, is -40.4 dBm. The lowest interference to signal power ratio is -5.4 dB

The Processing Gain is therefore

$$G_p = 17 + 2 - 5.4 = 13.6 \text{ dB}$$

Reference

[1] Intersil Product Data Sheet HFA3861B

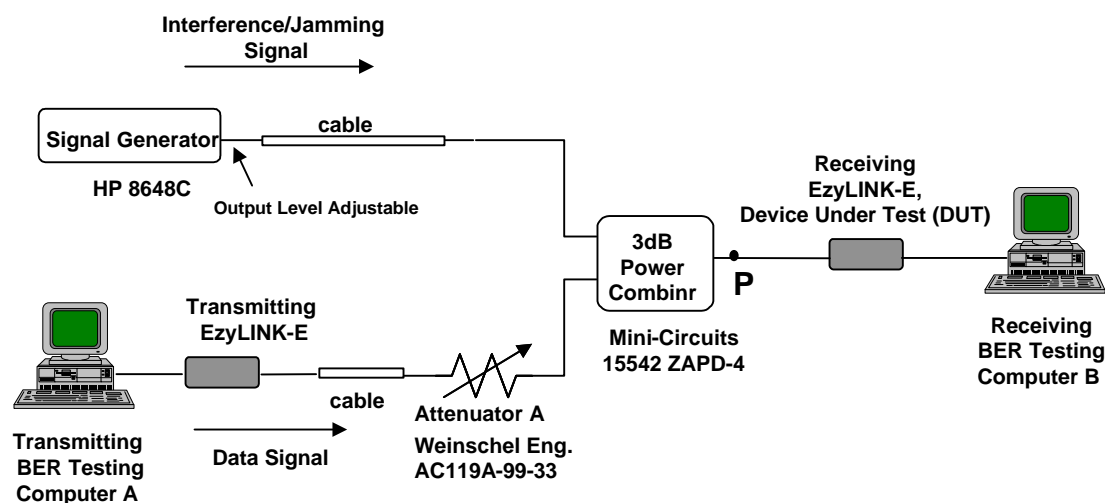

Figure 1. Processing Gain Measurement Setup for EzyLINK-E.