

REVISIONS				
ZONE	LTR	DESCRIPTION	DATE	APPR

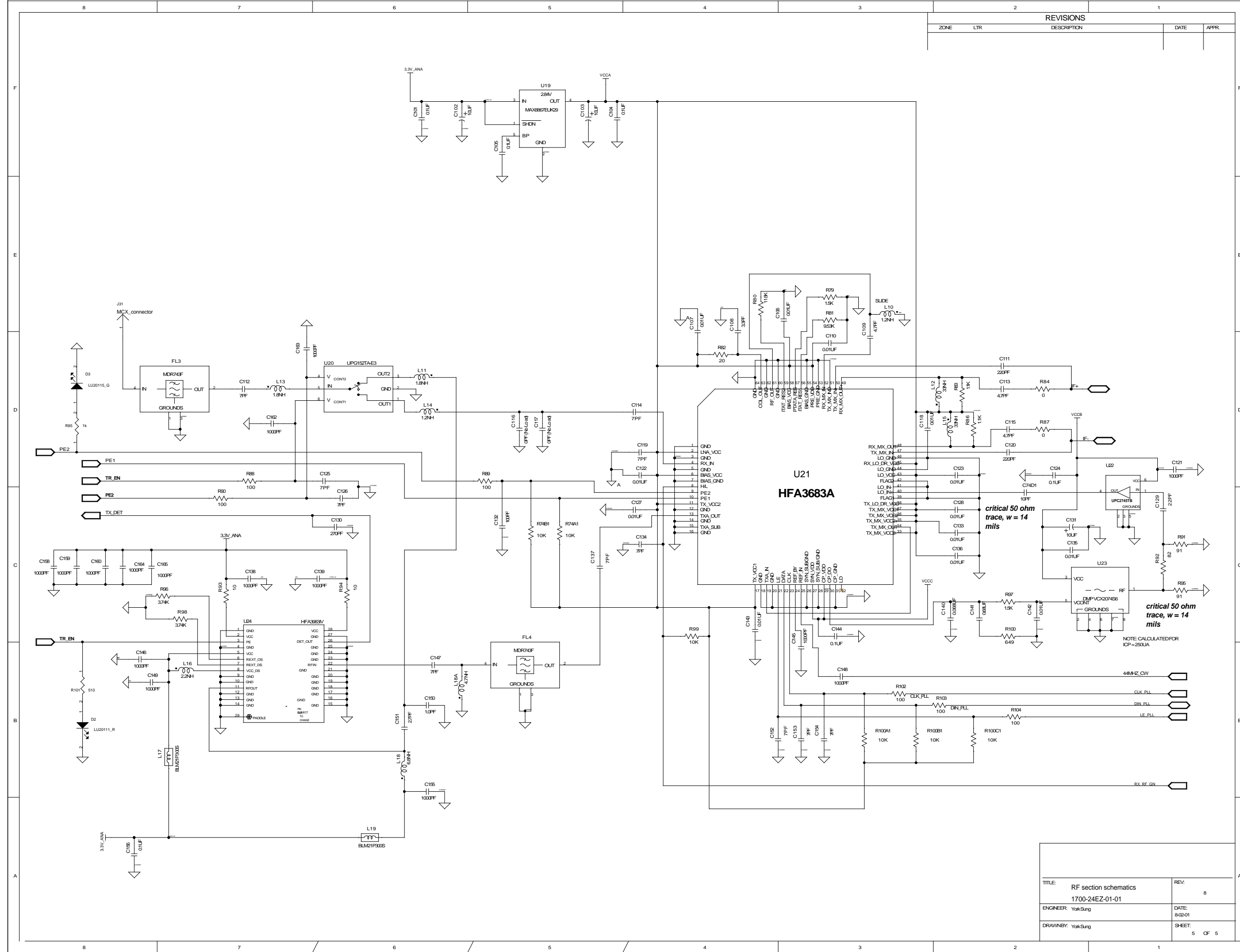

TITLE:	RF section schematics	REV:	8
ENGINEER:	YakSung	DATE:	8/2/01
DRAWNBY:	YakSung	SHEET:	5 OF 5

REVISIONS				
ZONE	LTR	DESCRIPTION	DATE	APPR

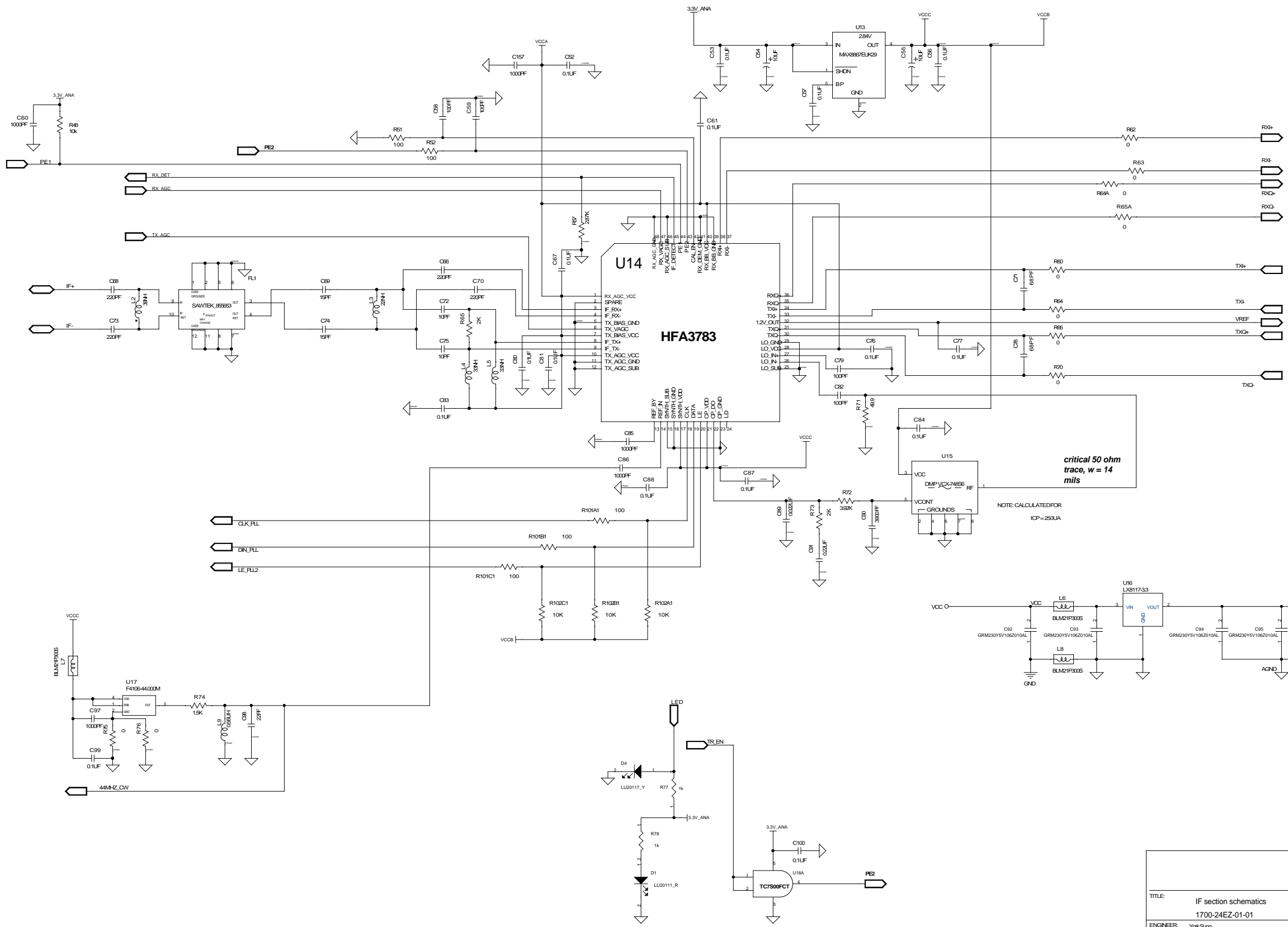

critical 50 ohm trace, w = 14 mils

NOTE: CALCULATED FOR ICP=250UA

TITLE: IF section schematics	REV: 8
ENGINEER: YarkSung	DATE: 8/2/01
DRAWNBY: YarkSung	SHEET: 4 OF 5

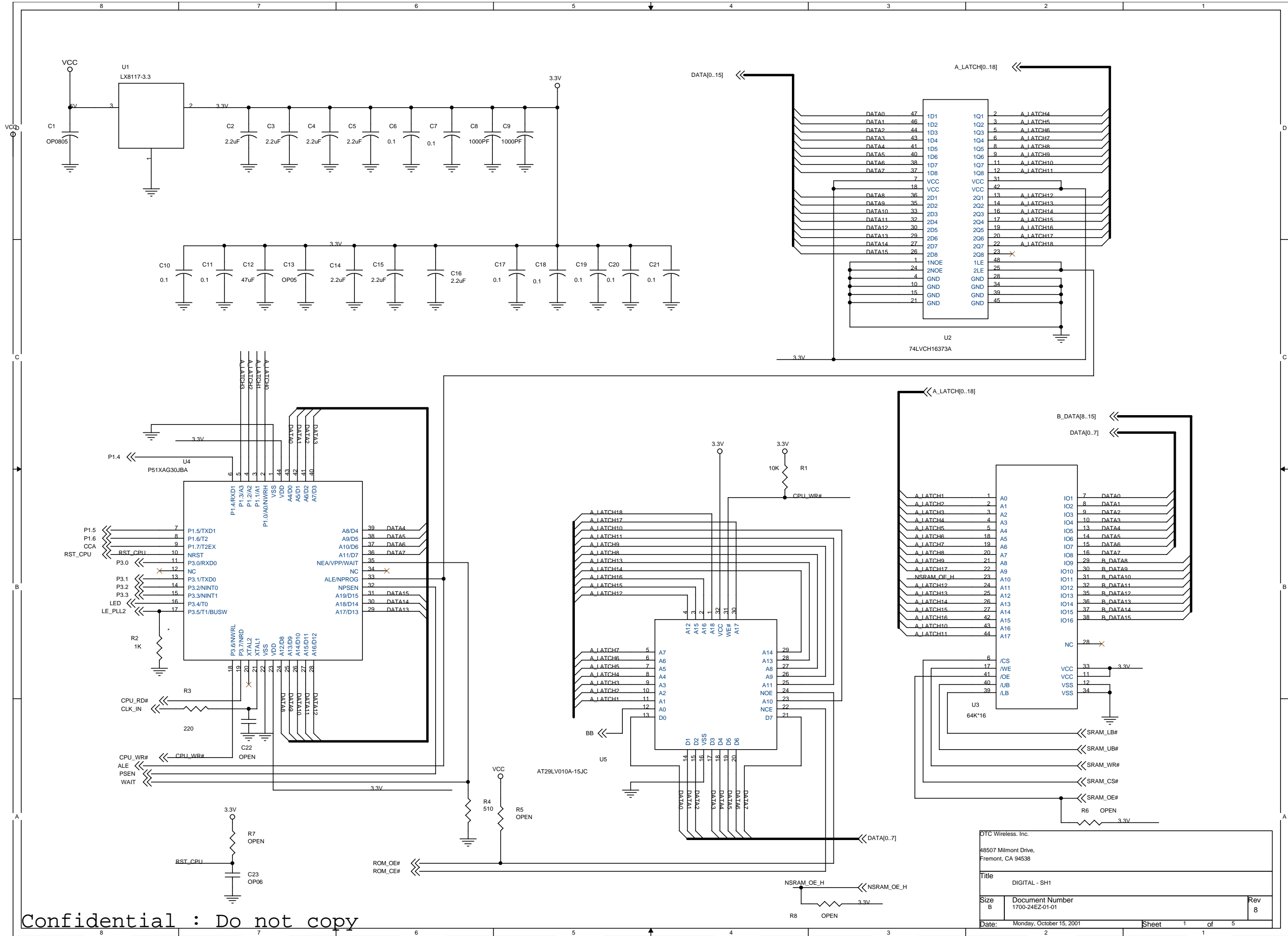

Confidential : Do not copy

OTC Wireless, Inc.		
48507 Milmont Drive, Fremont, CA 94538		
Title DIGITAL - SH1		
Size B	Document Number 1700-24EZ-01-01	Rev 8
Date: Monday, October 15, 2001	Sheet 1	of 5

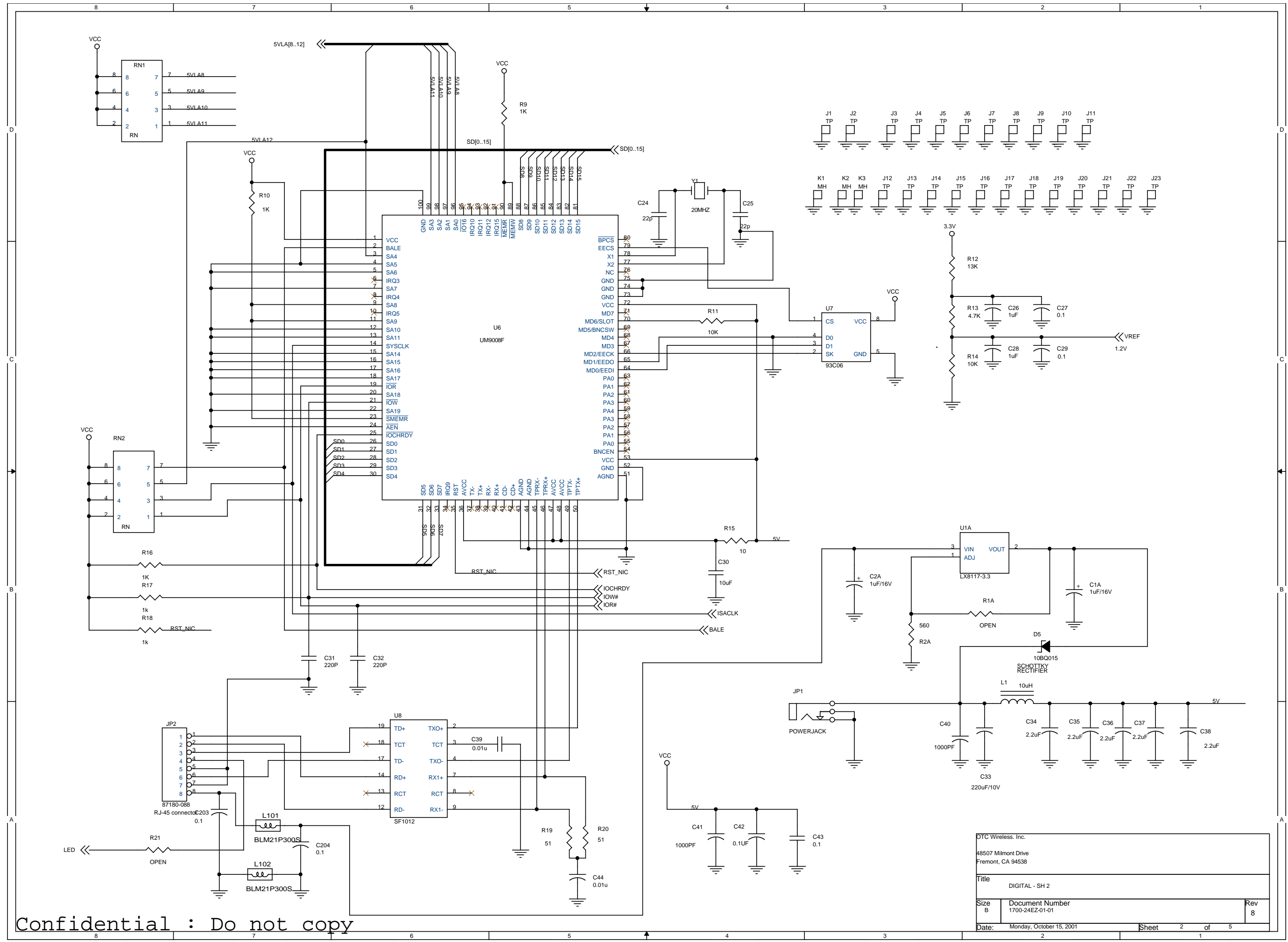

Confidential : Do not copy

DTC Wireless, Inc.		
48507 Milmont Drive Fremont, CA 94538		
Title DIGITAL - SH 2		
Size B	Document Number 1700-24EZ-01-01	Rev 8
Date: Monday, October 15, 2001	Sheet 2	of 5

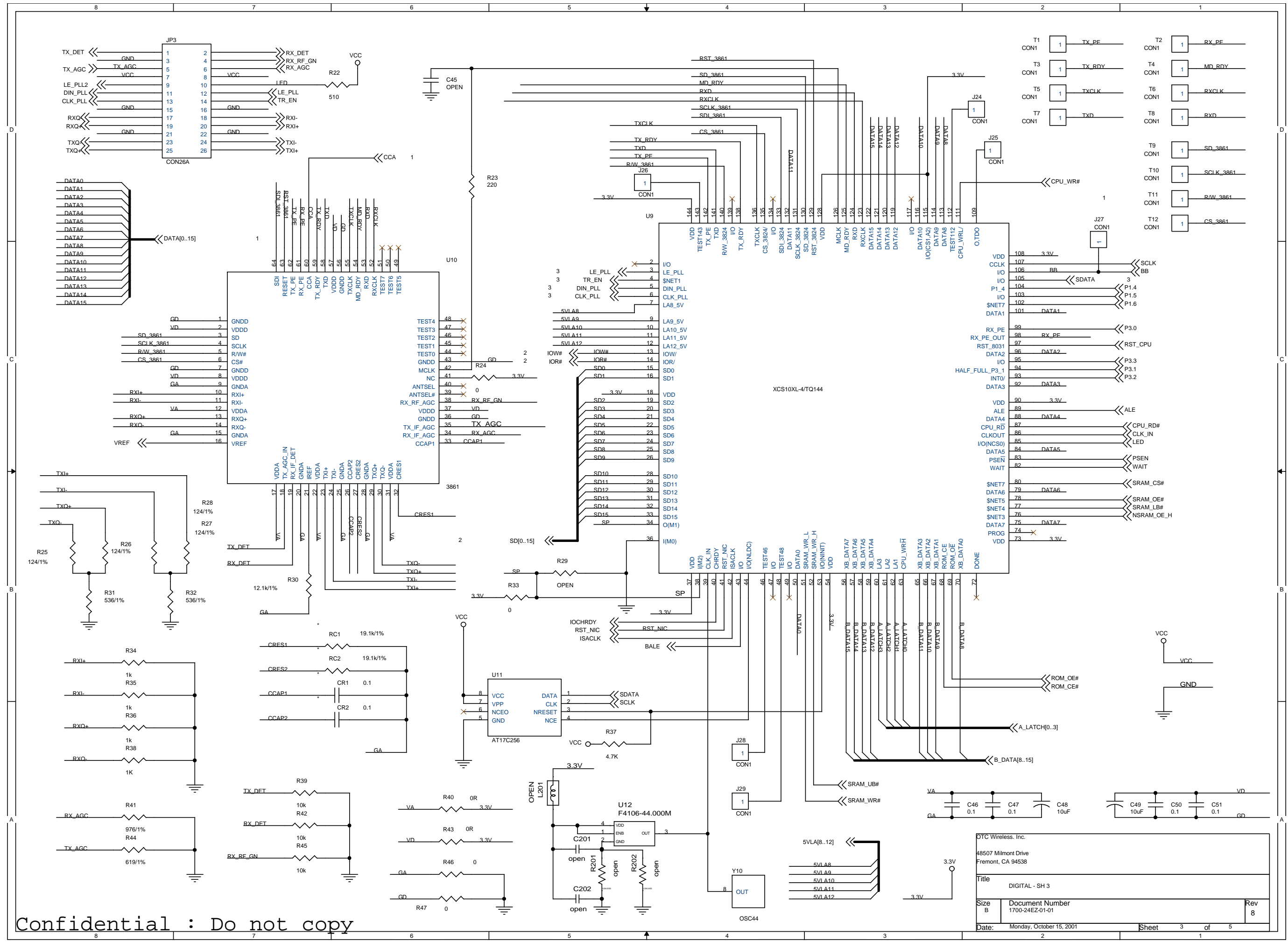

Confidential : Do not copy

DTC Wireless, Inc.	
48507 Milmont Drive Fremont, CA 94538	
Title DIGITAL - SH 3	
Size B	Document Number 1700-24EZ-01-01
Date: Monday, October 15, 2001	Rev 8
Sheet 3 of 5	