



KTL Ottawa

Safety - EMI - Telecom - ISO Guide 25

ENGINEERING TEST REPORT

ON:

"INET 'SPIDER B3' 4 WATT BOOSTER"

IN ACCORDANCE WITH:

MPE REQUIREMENTS OF THE FCC PART 1

PROJECT NO.: 8R00203.1

TESTED FOR:

INET INC.
1255 W. 15TH STREET
PLANO, TEXAS
75075-7270

TESTED BY:

KTL OTTAWA INC.
3325 RIVER ROAD, R.R. 5
OTTAWA, ONTARIO K1V 1H2

JUNE 1998

This document contains 21 pages including this one.

KTL Ottawa Inc. authorizes the above named company to reproduce this report provided it is reproduced in its entirety and for use by the company's employees only.

Any use which a third party makes of this report, or any reliance on or decisions to be made based on it, are the responsibility of such third parties. KTL Ottawa Inc. accepts no responsibility for damages, if any, suffered by any third party as a result of decisions made or actions based on this report.

This report applies only to the items tested.

TABLE OF CONTENTS

Section 1. Summary of Test Results

Test Rationale

Section 2. Equipment Under Test (E.U.T.)

Description of E.U.T.

Modifications Incorporated in E.U.T.

Theory of Operation

Justification

Exercise Program

Section 3. Equipment Configuration

Equipment Configuration List

Inter-connection Cables

Configuration of the Equipment Under Test (E.U.T.) Block Diagram

Section 4. Test Configuration A

Test #1

Test #2

Test #3 Measurements Inside Vehicle with Antenna Mounted In Center Of Roof

Test #4 Measurements Inside Vehicle with Antenna Mounted At Rear

Section 5. Configuration B

Test #1

Test #2

Test #3

Test #4

Test #5 Measurements Inside Vehicle

Test #6 Measurements Behind Panel Van

Section 6. Test Equipment

Section 7. Photos

EQUIPMENT: INET "Spider B3"4 Watt Booster

Section 1. Summary of Test Results

Test Rationale

This testing was patterned after testing done in FCC/OET document ASD-9601, "Measurements of Environmental Electromagnetic Fields at Amateur Radio Stations" and OET Bulletin 65 Edition 97-01, "Evaluating Compliance with FCC Guidelines for Human Exposure to Radiofrequency Electromagnetic Fields.

Emissions were measured using a standard Roberts type dipole antenna tuned to cellular channel 383. The measured field strength was then converted to Power Density by the following relation:

$$S = E^2/3770$$

where

S = power density (mW/cm²)

E = electric field strength (V/m)

This equation is given on page 9 of OET Bulletin 65.

Measurements were made with the E.U.T. feeding a magnetic roof mount antenna as prescribed by the manufacturer. Measurements were made with the system installed on two different vehicles; a standard passenger vehicle and a pickup truck. Field strengths were measured at distances from 0.5 to 3 metres. The receive antenna height was varied from 1 - 3 metres to determine maximum emission levels.

Measurements were also performed with the vehicle parked adjacent to a panel van in order to investigate "hot spots" that may be caused by reflection from a nearby metallic object.

Conclusion

In the configuration tested, the E.U.T. **complies** with the requirements of MPE Requirements of the FCC Part 1.

THIS TEST REPORT RELATES ONLY TO THE ITEM(S) TESTED.

THE FOLLOWING DEVIATIONS FROM, ADDITIONS TO, OR EXCLUSIONS FROM THE TEST SPECIFICATION HAVE BEEN MADE. None

Test Performed By: _____
Tom Tidwell, Senior Technologist

Date: _____

Approved By: _____
W. Waterhouse, RF Engineering Lab Manager

Date: _____

EQUIPMENT: INET "Spider B3" 4 Watt Booster

Section 2. Equipment Under Test (E.U.T.)

Manufacturer: INET Inc.

Model No.: "Spider B3"

Serial No.: None



Production Unit



Pre-Production Unit

Description of E.U.T.

The E.U.T. is a 4 watt booster for connection to the Spider PCMCIA CDPD modem.

Modifications Incorporated in E.U.T.

The EUT has not been modified from what is described by the brand name and unique type identification stated above.

EQUIPMENT: INET "Spider B3"4 Watt Booster

Theory Of Operation

The E.U.T. connects to the FCC approved "Spider" CDPD modem; (FCC ID: MIVWG9501A), to boost the Class III 0.6 watt modem power level to a 4 watt Class I output level. The booster uses duplexers at the input and output to split the Tx and Rx paths. The Tx path has three stages: Electronic Attenuator, PA Driver and PA. The Rx path has four stages: Preamp, SAW Filter, LNA and Electronic Attenuator.

Block Diagram

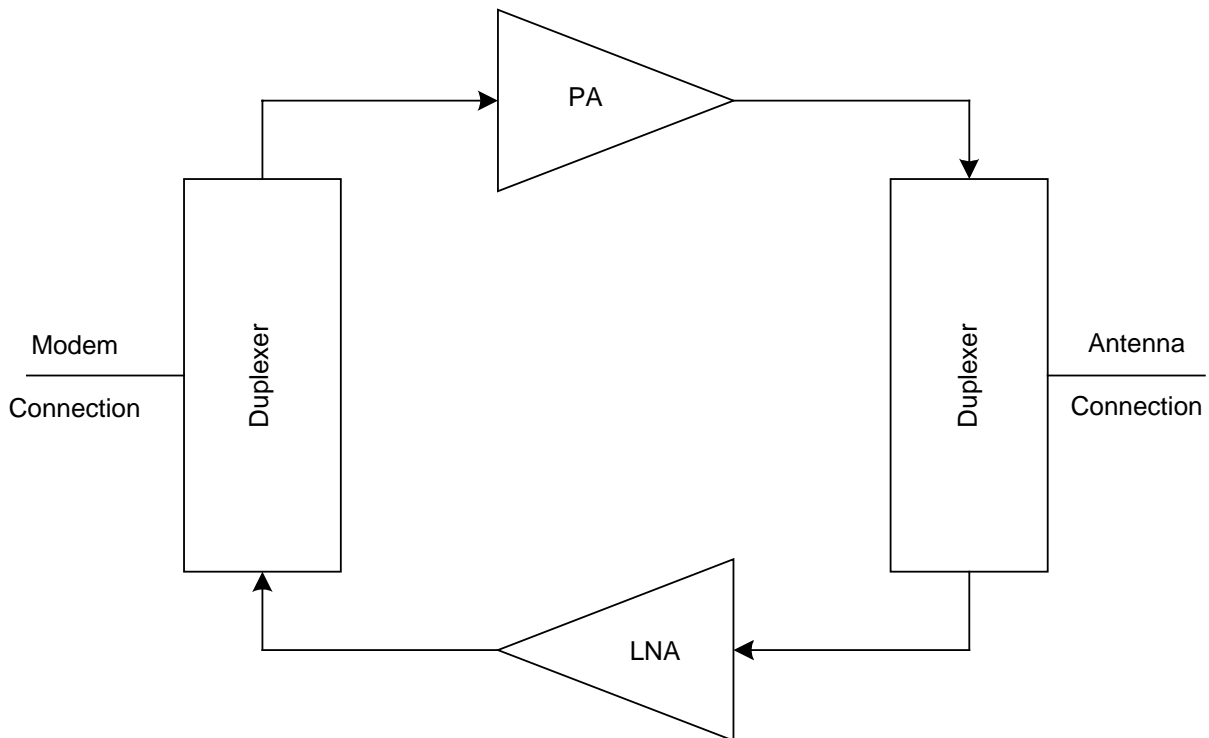

EQUIPMENT: INET "Spider B3"4 Watt Booster

Justification

The E.U.T. was configured for testing as per typical installation. Position and bundling of cables were investigated to establish maximum amplitude of emissions.

The following combinations were investigated to establish worst case configuration:

- (1) E.U.T. transmitting at 4 watts.
- (2) Antenna mounted in center of vehicle roof.
- (3) Antenna mounted at back of vehicle roof.
- (4) Vehicle parked adjacent to vertical metal surface.

Exercise Program

The E.U.T. exercise program used during testing was designed to exercise the various system components in a manner similar to typical use.

Exercise Mode:

Not Applicable.

EQUIPMENT: INET "Spider B3"4 Watt Booster

Section 3. Equipment Configuration

Equipment Configuration List:

Item	Description	Model No.	Serial.	Rev.
(A)	Toshiba Satellite Notebook PC	PA1196UV	10563296-1	
(B)	PCMCIA Modem	Spider	None	
(C)	Radio Shack Cellular Antenna	None	None	
(D)	4 Watt Booster	Spider B3	None	

Inter-connection Cables:

Item	Description	Length (m)
(1)	Coaxial Cable	4.0
(2)	Coaxial Cable	5.0
(3)	AWG 14 Wire	3.0

EQUIPMENT: INET "Spider B3" 4 Watt Booster

Configuration of the Equipment Under Test (E.U.T)

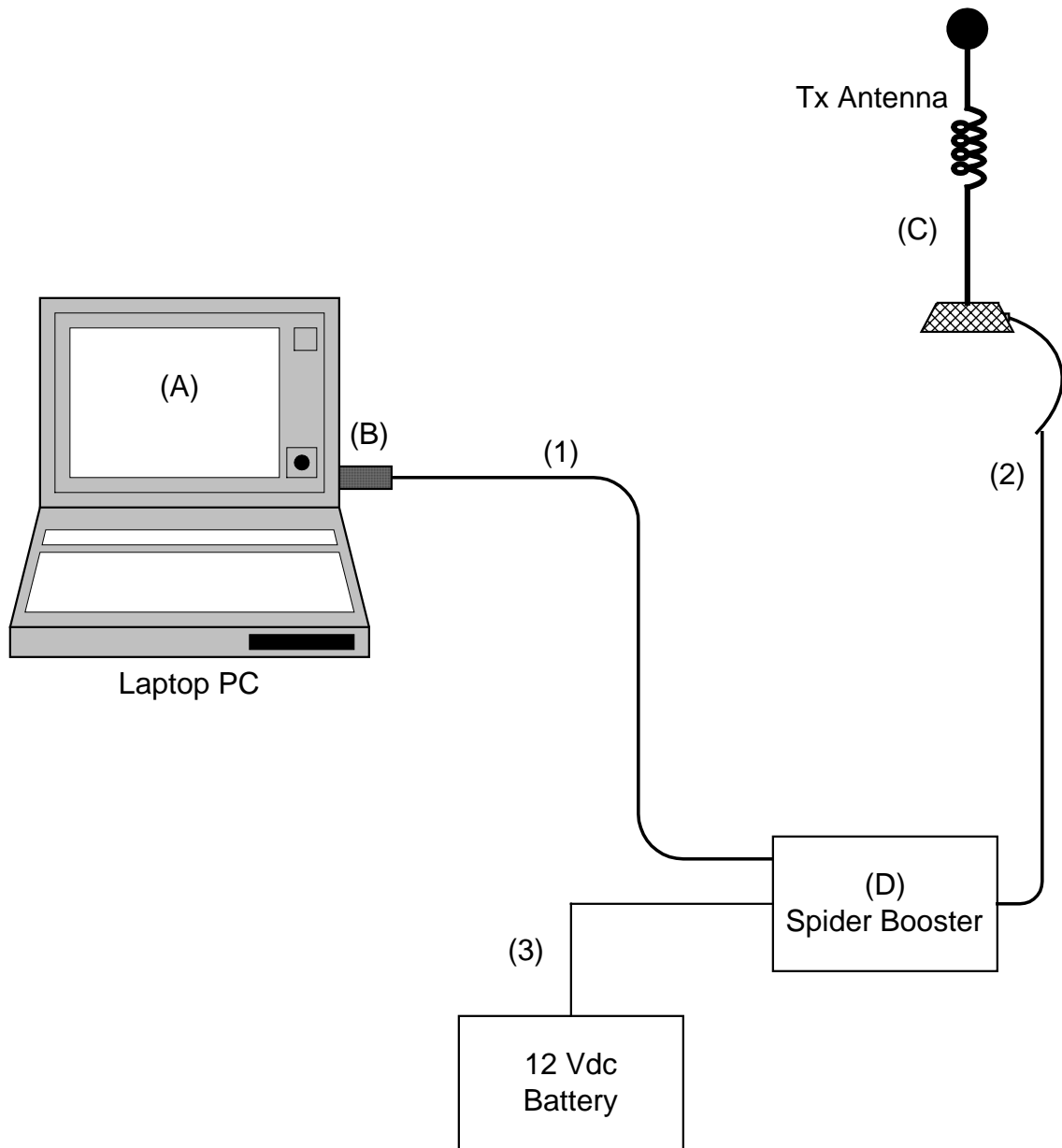

EQUIPMENT: INET "Spider B3"4 Watt Booster

Section 4. Test Configuration A

Transmit antenna: Radio Shack Magnetic Mount
 Receive antenna height: 1.5 - 2m
 Vehicle: 1998 4-Door Sedan
 Antenna mounted in center of roof

Test #1

MEASUREMENT POSITION		MEASUREMENT DISTANCE (metres)	MEASURED POWER DENSITY (mW/cm ²)	FCC LIMITS POWER DENSITY (mW/cm ²)
1		0.5	0.025	0.560
2		0.5	0.050	0.560
3		0.5	0.040	0.560
4		0.5	0.050	0.560
5		0.5	0.025	0.560
6		0.5	0.050	0.560
7		0.5	0.014	0.560
8		0.5	0.013	0.560
9		0.5	0.013	0.560

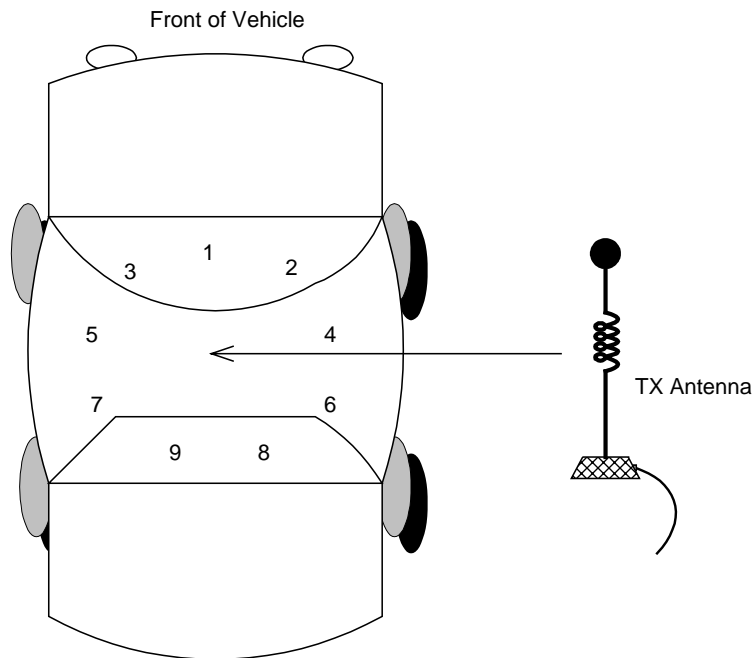

EQUIPMENT: INET "Spider B3"4 Watt Booster

Test #2

MEASUREMENT POSITION		MEASUREMENT DISTANCE (metres)	MEASURED POWER DENSITY (mW/cm ²)	FCC LIMITS POWER DENSITY (mW/cm ²)
1		1	0.008	0.560
2		1	0.006	0.560
3		1	0.008	0.560
4		1	0.008	0.560
5		1	0.008	0.560
6		1	0.008	0.560
7		1	0.008	0.560
8		1	0.007	0.560

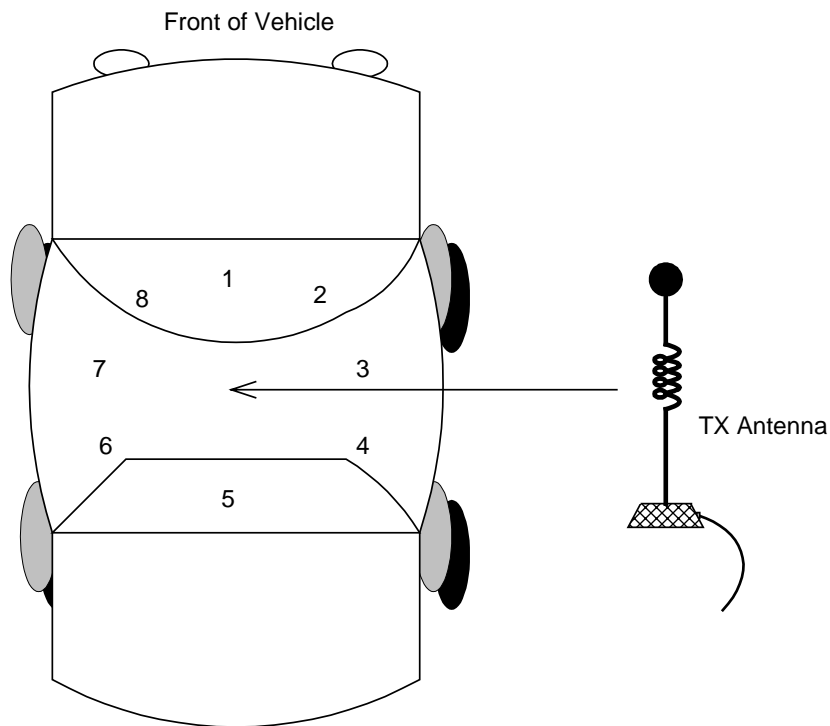

EQUIPMENT: INET "Spider B3"4 Watt Booster

Test #3 Measurements Inside Vehicle With Antenna Mounted In Center Of Roof

MEASUREMENT POSITION		MEASUREMENT DISTANCE (metres)	MEASURED POWER DENSITY (mW/cm ²)	FCC LIMITS POWER DENSITY (mW/cm ²)
1			0.025	0.560
2			0.000319	0.560
3			0.000420	0.560
4			0.000342	0.560
5			0.000392	0.560

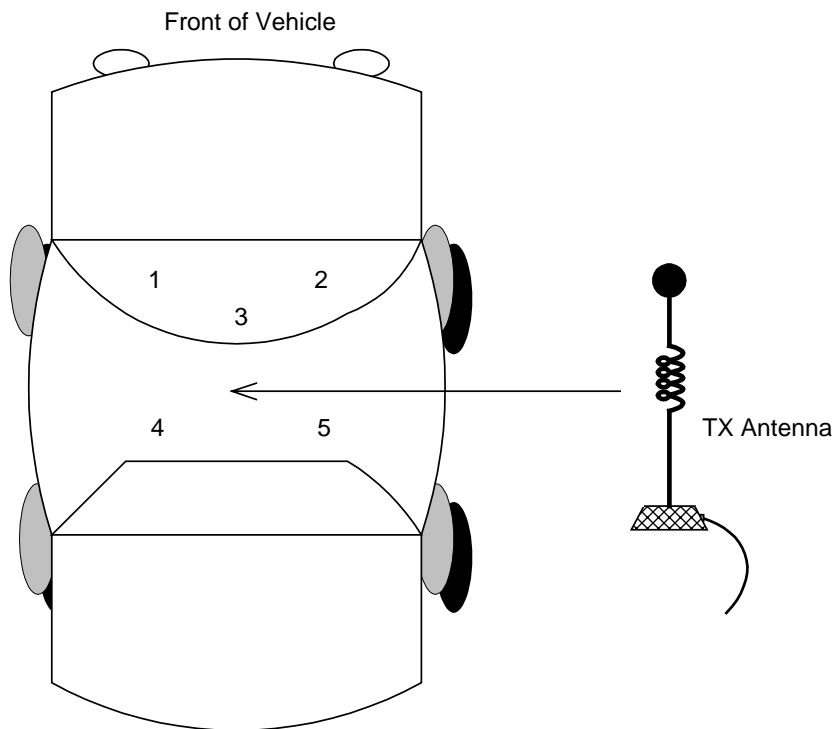

EQUIPMENT: INET "Spider B3"4 Watt Booster

Test #4 - Measurements Inside Vehicle With Antenna Mounted At Rear

MEASUREMENT POSITION		MEASUREMENT DISTANCE (metres)	MEASURED POWER DENSITY (mW/cm ²)	FCC LIMITS POWER DENSITY (mW/cm ²)
1	Back Seat Left		0.00451	0.560
2	Back Seat Center		0.00278	0.560
3	Back Seat Right		0.00142	0.560

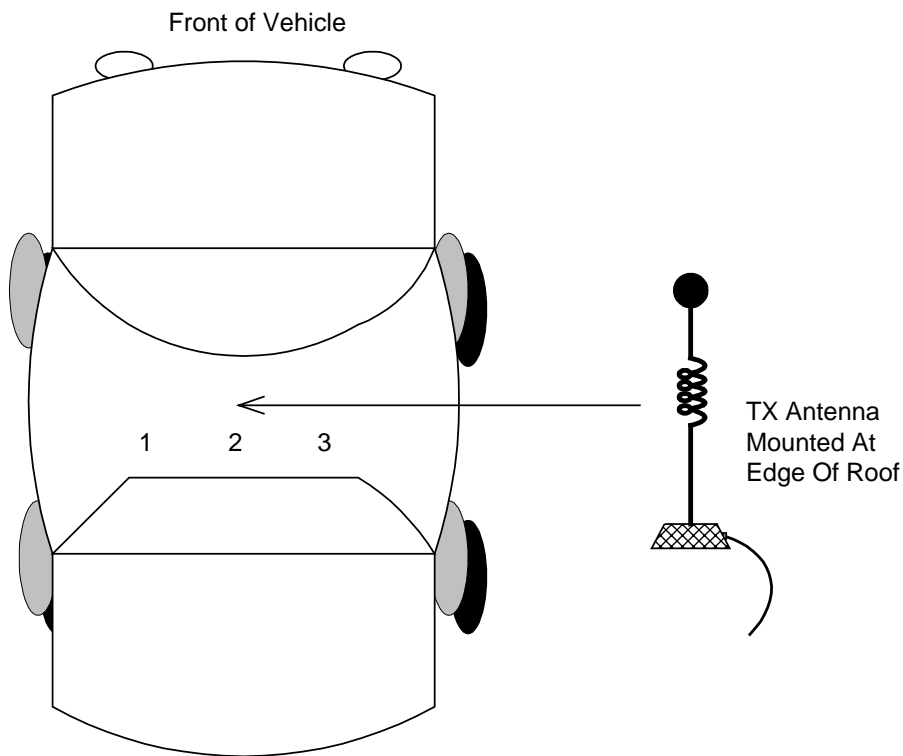

EQUIPMENT: INET "Spider B3"4 Watt Booster

Section 5. Test Configuration B

Transmit antenna: Radio Shack Magnetic Mount
 Receive antenna height: 1.5 - 2m
 Vehicle: 1993 Ford Ranger Pickup truck
 Antenna mounted in center of roof

Test #1

MEASUREMENT POSITION		MEASUREMENT DISTANCE (metres)	MEASURED POWER DENSITY (mW/cm ²)	FCC LIMITS POWER DENSITY (mW/cm ²)
1		0.5	0.0311	0.560
2		0.5	0.0271	0.560
3		0.5	0.0310	0.560
4		0.5	0.0310	0.560

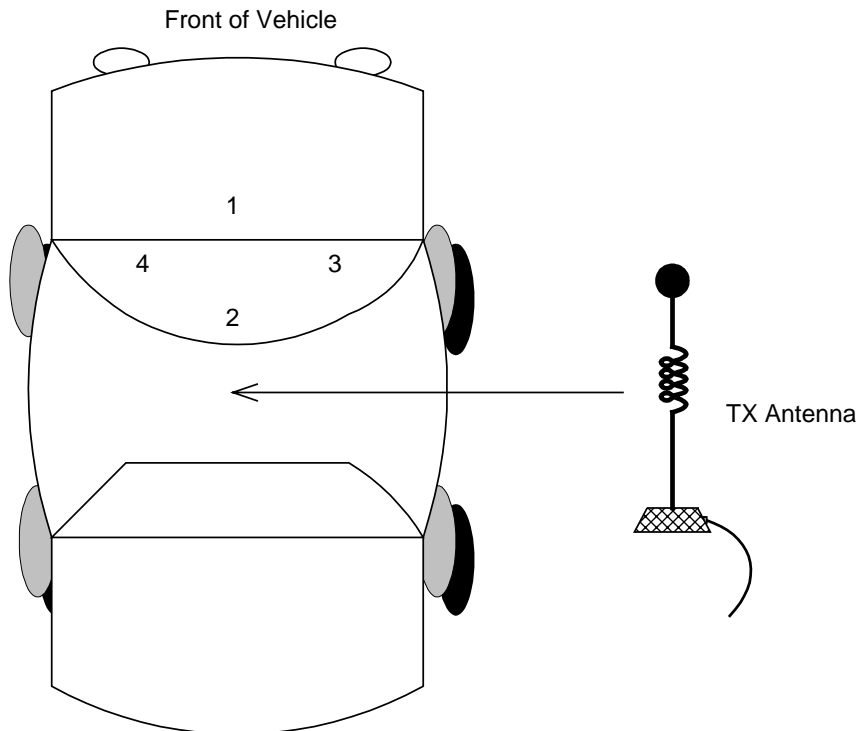

EQUIPMENT: INET "Spider B3"4 Watt Booster

Test #2

MEASUREMENT POSITION		MEASUREMENT DISTANCE (metres)	MEASURED POWER DENSITY (mW/cm ²)	FCC LIMITS POWER DENSITY (mW/cm ²)
1		1	0.00575	0.560
2		1	0.00734	0.560
3		1	0.00872	0.560
4		1	0.00572	0.560

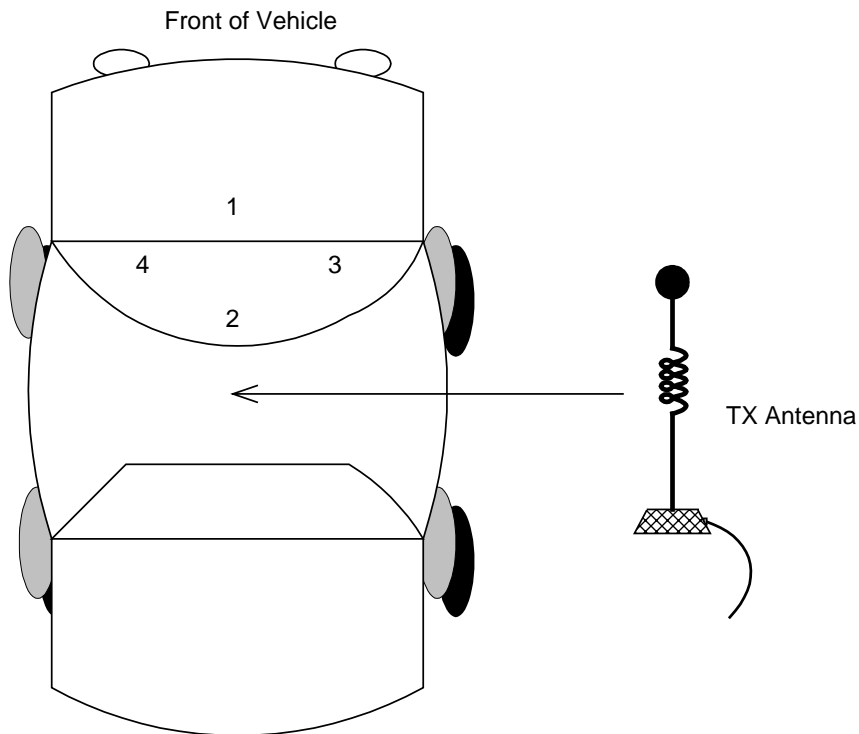

EQUIPMENT: INET "Spider B3"4 Watt Booster

Test #3

MEASUREMENT POSITION		MEASUREMENT DISTANCE (metres)	MEASURED POWER DENSITY (mW/cm ²)	FCC LIMITS POWER DENSITY (mW/cm ²)
1		2	0.00116	0.560
2		2	0.00302	0.560
3		2	0.00147	0.560
4		2	0.00183	0.560

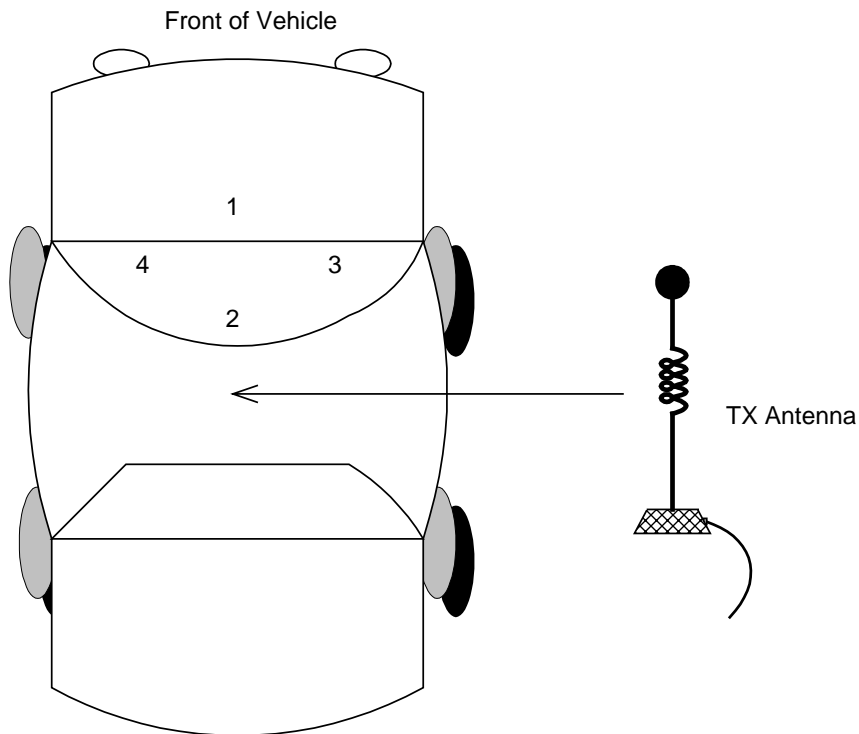

EQUIPMENT: INET "Spider B3"4 Watt Booster

Test #4

MEASUREMENT POSITION		MEASUREMENT DISTANCE (metres)	MEASURED POWER DENSITY (mW/cm ²)	FCC LIMITS POWER DENSITY (mW/cm ²)
1		3	0.000920	0.560
2		3	0.000791	0.560
3		3	0.000611	0.560
4		3	0.000871	0.560

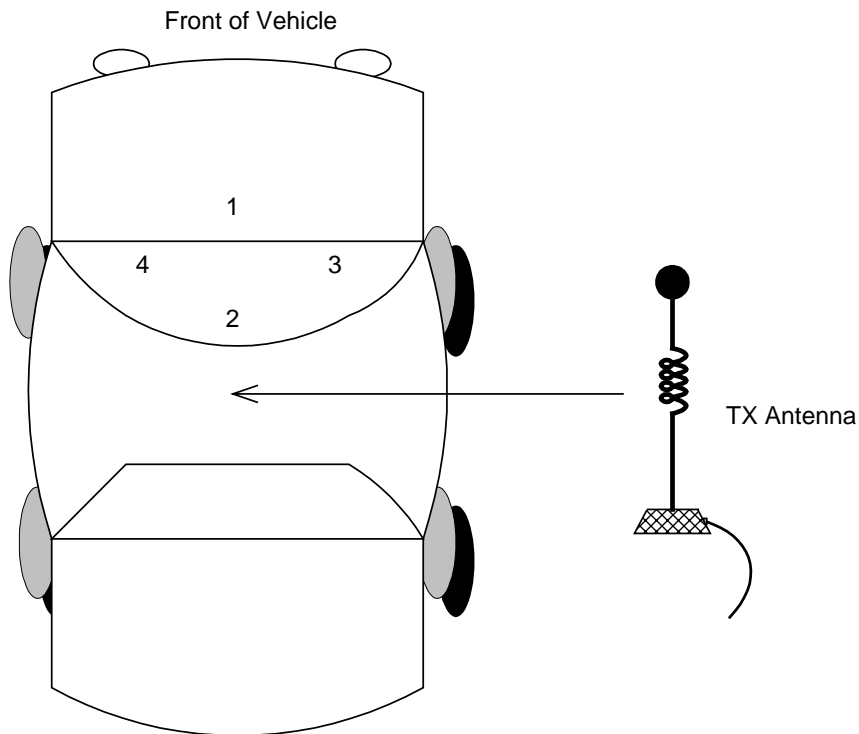

EQUIPMENT: INET "Spider B3"4 Watt Booster

Test #5 - Measurements Inside Vehicle

MEASUREMENT POSITION		MEASUREMENT DISTANCE (metres)	MEASURED POWER DENSITY (mW/cm ²)	FCC LIMITS POWER DENSITY (mW/cm ²)
1	Driver side		0.000738	0.560
2	Passenger side		0.000817	0.560

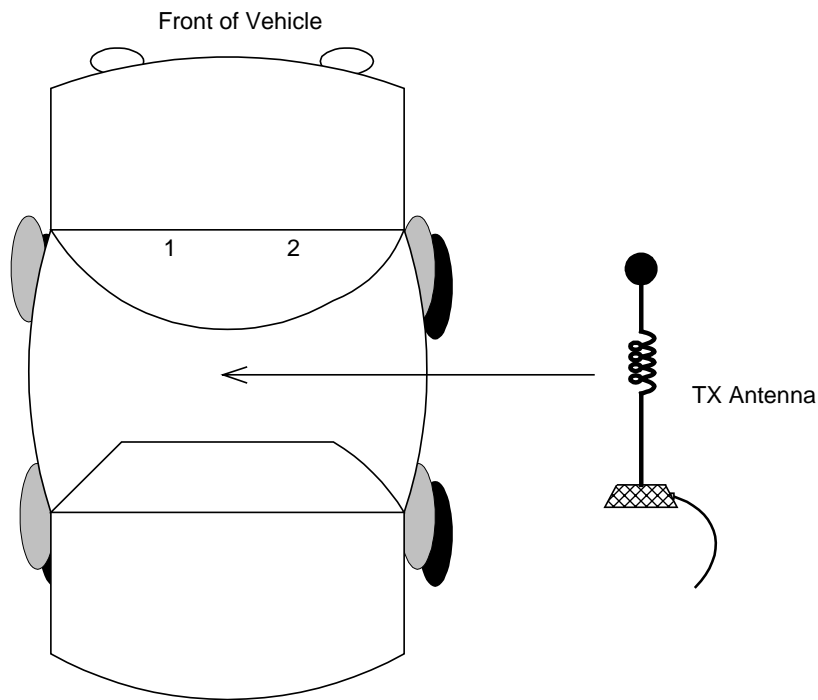

EQUIPMENT: INET "Spider B3"4 Watt Booster

Test #6 - Measurements Beside Panel Van

MEASUREMENT POSITION		MEASUREMENT DISTANCE (metres)	MEASURED POWER DENSITY (mW/cm ²)	FCC LIMITS POWER DENSITY (mW/cm ²)
1			0.002	0.560
2			0.002	0.560

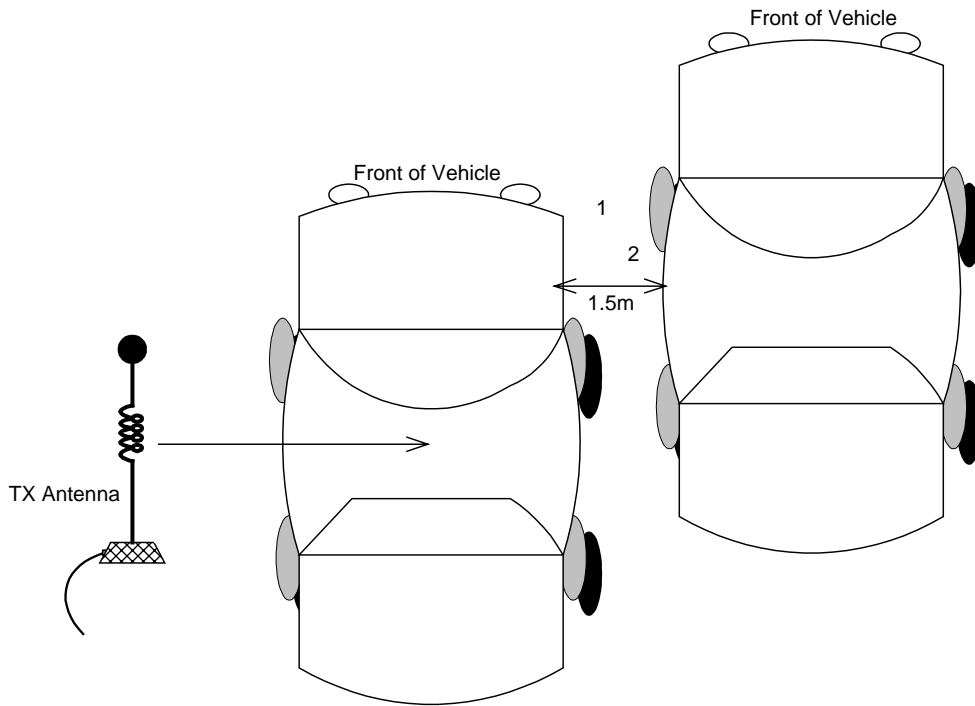

EQUIPMENT: INET "Spider B3"4 Watt Booster

Section 6. Test Equipment

Equipment List - Radiated Emissions

CAL Cycle	Equipment	Manufacturer	Model #	Serial/Asset #	Last Cal.	Next Cal.
1 Year	Dipole Antenna Set	EMCO	3121C	1029	Oct. 28/97	Oct. 28/98
1 Year	Spectrum Analyzer	Hewlett-Packard	8565E	865366	Feb. 27/98	Feb. 27/99

Note: N/A = Not Applicable
NCR = No Cal Required

EQUIPMENT: INET "Spider B3" 4 Watt Booster

Section 7. Photographs

Test Configuration A

Antenna On Center Of Roof



Antenna On Back Of Roof



EQUIPMENT: INET "Spider B3" 4 Watt Booster

Test Configuration B

Antenna Configuration



Near Field Power Density Measurement

