

**TEST REPORT**

**Report Number: 3091531DAL-001**  
**Project Number: 3091531**

**Evaluation of the**  
**Wireless MODEM**  
**Model Number: MLG0208**  
**FCC ID: MIVMLG0208**

**FCC Part 2**  
**FCC Part 15**  
**FCC Part 22 Subpart H**  
**FCC Part 24 Subpart E**

**For**  
**Enfora**

Test Performed by:  
  
Intertek  
420 N Dorothy Drive  
Richardson, TX 75081

Test Authorized by:  
  
Enfora  
661 E. 18<sup>th</sup> Street  
Plano, TX 75074

**Prepared By:** Skamble **Date:** 04/04/06  
Sudesh Kamble, EMC Team Leader

**Approved By:** Roland W. Gubisch **Date:** 4-4-2006  
Roland Gubisch, Chief Engineer,  
EMC and Telecom

*This report is for the exclusive use of Intertek's Client and is provided pursuant to the agreement between Intertek and its Client. Intertek's responsibility and liability are limited to the terms and conditions of the agreement. Intertek assumes no liability to any party, other than to the Client in accordance with the agreement, for any loss, expense or damage occasioned by the use of this report. Only the Client is authorized to copy or distribute this report and then only in its entirety. Any use of the Intertek name or one of its marks for the sale or advertisement of the tested material, product or service must first be approved in writing by Intertek. The observations and test results in this report are relevant only to the sample tested. This report by itself does not imply that the material, product, or service is or has ever been under an Intertek certification program.*



**TABLE OF CONTENTS**

**1 JOB DESCRIPTION .....4**

1.1 GENERAL INFORMATION .....4

    1.1.1 System Support Equipment.....5

    1.1.2 Cables associated with EUT .....5

    1.1.3 System Block Diagram .....5

    1.1.4 Mode(s) of operation.....5

**2 EXECUTIVE SUMMARY.....6**

2.1 REPORT REVISION HISTORY: .....6

**3 TEST FACILITY.....7**

3.1 TEST EQUIPMENT USED.....8

**4 CONDUCTED RF POWER .....9**

4.1 TEST PROCEDURE .....9

4.2 TEST RESULTS .....9

**5 RADIATED RF POWER.....10**

5.1 TEST LIMITS.....10

5.2 TEST PROCEDURE .....10

5.3 TEST RESULTS .....11

**6 MAXIMUM PERMISSIBLE EXPOSURE (MPE) CALCULATIONS .....12**

6.1 TEST LIMITS.....12

6.2 TEST PROCEDURE .....12

6.3 TEST RESULTS .....12

**7 EMISSION LIMITATIONS, OCCUPIED BANDWIDTH .....13**

7.1 TEST LIMITS.....13

7.2 TEST PROCEDURE .....13

7.3 TEST RESULTS .....13

**8 OUT OF BAND EMISSION AT ANTENNA TERMINALS.....20**

8.1 TEST LIMITS.....20

8.2 TEST PROCEDURE .....20

8.3 TEST RESULTS .....21

**9 FIELD STRENGTH OF SPURIOUS RADIATION .....29**

9.1 TEST LIMITS.....29

9.2 TEST PROCEDURE .....29

9.3 TEST RESULTS .....29

**10 POWER LINE CONDUCTED EMISSIONS.....32**

10.1 TEST LIMITS.....32

10.2 TEST PROCEDURE .....32

10.3 TEST RESULTS .....33

**11 RECEIVER SPURIOUS EMISSIONS .....35**

11.1 TEST LIMITS.....35

11.2 TEST PROCEDURE .....35

11.3 TEST RESULTS .....36

**12 FREQUENCY STABILITY VS TEMPERATURE .....37**

12.1 TEST LIMITS.....37

12.2 TEST PROCEDURE .....37

12.3 TEST RESULTS .....37

**13 FREQUENCY STABILITY VS VOLTAGE .....38**

13.1 TEST LIMITS.....38

13.2 TEST PROCEDURE .....38

13.3 TEST RESULTS .....38

Evaluation For: Enfora  
Model No: MLG0208

**FCC ID: MIVGSM0208**

<b>14</b>	<b>TEST SET UP PICTURES .....</b>	<b>39</b>
14.1	RADIATED EMISSIONS .....	39
14.2	AC LINE CONDUCTED EMISSIONS .....	40
<b>15</b>	<b>EUT PICTURES .....</b>	<b>41</b>

Evaluation For: Enfora  
 Model No: MLG0208

**FCC ID: MIVGSM0208**

## 1 JOB DESCRIPTION

### 1.1 General Information

<b>Applicant Name / Address:</b>	Enfora 661 E. 18 <sup>th</sup> Street, Plano, TX 75074
<b>Name of contact:</b>	Scott Yarberry
<b>Telephone:</b>	001 972 633-4400
<b>Fax:</b>	001 972 633-4444

<b>FCCID</b>	<b>MIVMLG0208</b>	
<b>Product</b>	Wireless MODEM	
<b>EUT Model Number</b>	MLG0208	
<b>EUT Serial Number</b>	None	
<b>Quantity Production Planned</b>	Quantity production is planned.	
<b>Modulation(s)</b>	GSM 1900 and GSM 850	
<b>Emission Designators</b>	300KGXW; 300KG7W	
<b>Frequency Tolerance</b>	± 2.5 ppm	
<b>Max. DC Voltage and Current to RF Input stage</b>	4.5 VDC, 1.25A	
<b>Maximum conducted power averaged over burst duration</b>	31.74 dBm (GSM 850); 27.96 dBm (GSM 1900)	
<b>Frequency Range</b>	<b>FCC Rules</b>	<b>Freq.(MHz)</b>
	22H	824.0 – 849.0
	24E	1850.0 – 1910.0
<b>Antenna &amp; Gain</b>	Max antenna Gain calculated: 7.11 dB for the 850 MHz band and 5.04 for 1900 MHz band to meet the limits. Manufacturer specified antenna gain is +3.3 dBi.	
<b>Detachable Antenna</b>	Yes	
<b>Related Submittals / Grants</b>	None	
<b>EUT receive date:</b>	02/11/06	
<b>EUT receive condition:</b>	The EUT was received in good condition with no apparent damage.	
<b>Test start date:</b>	02/11/06	
<b>Test completion date:</b>	02/15/06	
<b>FCC Rule Part(s)</b>	FCC Part 22 Subpart H, Part 24 Subpart E, Part 15, Part 2	
<b>Industry Canada Rule Part(s)</b>	RSS-132, RSS-133, ICES-003	
<b>Modifications Required For Compliance</b>	No modifications were implemented by the Intertek staff.	

The test results in this report pertain only to the item tested.

**1.1.1 System Support Equipment**

Table 1-1 contains the details of the support equipment associated with the Equipment Under Test during the FCC Part 15 testing.

*Table 1-1: System Support Equipment*

Description	Manufacturer	Model Number	Serial Number
AC Adapter	nextcell	MKD-41090500	BKLWN9D5E1P7
PC	ACER	Aspire 3500	LXA500510052000 7EFEM00
Test Jig	ENFORA	SDK0107MG001 Rev D	101

**1.1.2 Cables associated with EUT**

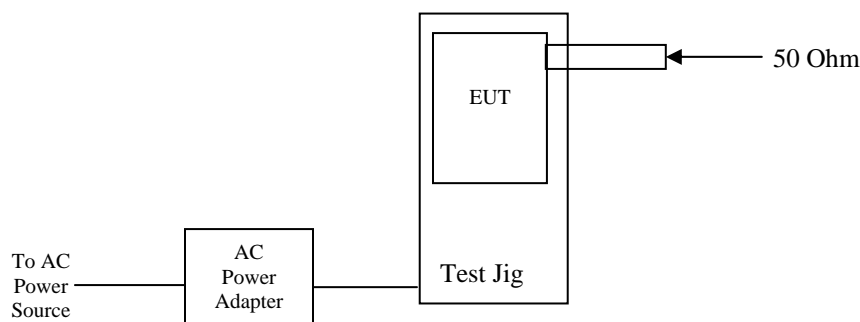
Table 1-2 contains the details of the cables associated with the EUT.

*Table 1-2: Interconnecting cables between modules of EUT*

Cables					
Description	Length	Shielding	Ferrites	Connection	
				From	To
DC Power Cord	5 ft	None	None	AC Power Adapter	Test Jig

**1.1.3 System Block Diagram**

The diagram shown below details the interconnection of the EUT and its accessories during FCC Part 15 testing. For specific layout, refer to the test configuration photograph in the relevant section of this report.



**1.1.4 Mode(s) of operation**

The Wireless MODEM was powered by the AC to DC power supply provided with the sample and tested in the stand alone configuration.

The appliance under test was operated with **GMSK modulation mode only (no other mode of modulation used in EUT)**.

## 2 EXECUTIVE SUMMARY

Testing performed for: Enfora

Equipment Under Test: Wireless Modem Model MLG0208

FCC RULE	IC RULE	DESCRIPTION OF TEST	RESULT	PAGE	Test Date
§2.1046	RSS-132 §6.4 RSS-133 §6.2	RF Power Output	Pass	9	02/13/06
§22.913, §24.232	RSS-132 §6.4 RSS-133 §6.2	ERP, EIRP	Pass	10	02/13/06
§1.1310, §2.1091, §2.1093	RSS-132 §5.7 RSS-133 §8	Maximum Permissible Exposure Calculations	Pass	12	02/13/06
§2.1049 §22.917(b)(d)	RSS-132 §6.5 RSS-133 §6.3	Emission Limitation, Occupied Bandwidth	Pass	13	02/13/06
§2.1051 §22.917(e) §22.917(f) §24.238(a)	RSS-132 §6.5 RSS-133 §6.3	Out of Band Emissions at Antenna Terminals	Pass	20	02/13/06
§2.1053, §22.917, §24.238	RSS-132 §6.6	Field Strength of Spurious Radiation	Pass	29	02/14/06
§15.107, §15.207	IC ES-003	Power Line Conducted Emissions	Pass	33	02/14/06
§15.109, §15.209	IC ES-003 RSS-132 §6.6 RSS-133 §9	Receiver Spurious Emission	Pass	36	02/14/06
§2.1055, §22.355, §24.235	RSS-132 §6.3 RSS-133 §7	Frequency Stability vs. Temperature	Pass	38	02/15/06
§2.1055, §22.355, §24.235	--	Frequency Stability vs. Voltage	Pass	39	02/15/06

N/S: Not under scope of this evaluation

### 2.1 Report revision history:

<u>Date/Project #</u>	<u>Project Handler</u>	<u>Page</u>	<u>Item</u>	<u>Description of Change</u>
04/03/06 3091531	S Kamble	4	All	Added the DC voltage and current RF Stage
		11	Sec. 5.3 Table 5-1	Updated ERP/EIRP Calculations
		12	Sec. 6.3	Updated MPE Calculations
		30-31	Sec. 9.3 Table 9-1	Updated EIRP Calculations

### **3 TEST FACILITY**

The INTERTEK is located at 420 N Dorothy Drive, Richardson, TX 75081. The radiated emission test site is a 3-meter semi-anechoic chamber. The chamber meets the characteristics of CISPR 16-1-4:2003 and ANSI C63.4:2003. For measurements, a remotely controlled flush-mount metal-top turntable is used to rotate the EUT a full 360 degrees. A remote controlled non-conductive antenna mast is used to scan the antenna height from one to four meters.

The FCC site registration number for this site is 10157.

The Industry Canada file no. is IC 6018.

### 3.1 Test Equipment Used

Description	Manufacturer	Model Number	Serial Number	Calibration due date	Eqpt. ID
Signal Generator	Hewlett Packard	83620A	3213A01244	12/01/06	HEW62
Environmental Chamber	Thermotron	SE-600-5-5	29513	12/21/2006	124
EMI Receiver	Rohde & Schwarz	ESI 7	100044	10/14/2006	77
Spectrum Analyzer	Agilent Technologies	E7405A	US40240235	11/23/2006	87
Horn Antenna	A H Systems	SAS-571	411	08/16/2006	86
Horn Antenna	A H Systems	SAS-571	787	02/08/2007	271
Bi-coniLog Antenna	Schaffner	CBL6112B	2726	06/06/2006	82
RF Cable	custom made	#1	none	07/28/2006	128
RF Cable	Custom made	#4	none	07/28/2006	131
RF Cable	Custom made	#8	none	08/25/2006	130
Preamplifier	Miteq, Inc.	AMF-4D-001180-24-10P	1020106	07/28/2006	222
Attenuator	JFW	50FHC-020-20	50FHC-020-20	05/02/2006	223
Digital Multimeter	Fluke	8060A	6636042	06/17/2006	11
Power Meter	HP	HP 8482H	3318A07268	08/16/2006	95
LISN	FCC	FCC-LISN-50-25-2-01	01020	06/02/2006	91
Base Station Simulator	Agilent	8960 Series 10, E5515C	GB44400984	01/13/07	N/A
DC Power supply	Topward P.S.	33010D	697464	VBU	106
Power Source	Pacific Power	140TMX	00724/0248	07/15/2006	85

Note: The calibration due dates of test equipments used are noted as on the day of testing.



**4 CONDUCTED RF POWER**

FCC Rule: §2.1046

IC Rule: RSS-132 §6.4 and RSS-133 §6.2

**4.1 Test Procedure**

The transmitter output was connected to a calibrated coaxial cable. The EUT was set to its maximum power setting. The EUT was placed into a call and the transmitter output was read off the Power meter in dBm. The power output at the transmitter antenna port was determined by adding the value of the cable insertion loss.

Tests were performed at three frequencies (low, middle, and high channels) and on the highest power levels, which can be setup on the transmitters.

The transmission was exercised in burst mode to generate maximum power, the power was averaged shall be averaged over the burst duration, during which its power value is at its maximum. The power measurement was averaged only over the durations of actual transmission. Gated Average detector was used during transmitted and out of band power measurements.

EUT’s internal test mode was accesses and programmed by an external PC for operation.

**4.2 Test Results**

The EUT met the RF power output requirements of FCC Part 22 Subpart H and FCC Part FCC Part 24 Subpart E. The test results are located in Table 4-1.

*Table 4-1 RF Power Variation with temperature*

<b>Power Variation (peak) Vs. Temperature (dBm)</b>						
<b>Temp. (Celcius)</b>	<b>GSM 850 Channel #</b>			<b>GSM 1900 Channel #</b>		
	<b>128</b>	<b>190</b>	<b>251</b>	<b>512</b>	<b>662</b>	<b>810</b>
60	-0.35	0.32	-0.40	-0.29	-0.12	-0.46
20	0.00	0.00	0.00	0.00	0.00	0.00
-10	0.34	0.37	0.29	0.15	0.16	0.26
-30	0.17	0.58	0.50	0.27	0.26	0.41

<b>Power (Avg.) at ambient (dBm)</b>							
<b>Modulation</b>	<b>Temp. (Celcius)</b>	<b>GSM 850 Channel #</b>			<b>GSM 1900 Channel #</b>		
		<b>128</b>	<b>190</b>	<b>251</b>	<b>512</b>	<b>662</b>	<b>810</b>
<b>GMSK</b>	<b>22.4</b>	<b>31.74</b>	31.52	31.32	26.40	27.24	<b>27.96</b>
<b>Freq</b>		824.20040080	836.54509018	848.90581162	1.85016008	1.88018802	1.90981214

**NOTE:** Maximum conducted output power, averaged over the entire duty cycle: 31.74 dBm (GSM 850 Band); 27.96 dBm (GSM 1900 Band)

Evaluation For: Enfora  
Model No: MLG0208**FCC ID: MIVGSM0208**

## 5 RADIATED RF POWER

FCC Rule §22.913

FCC Rule §24.232; RSS-133 §6.2

RSS-132 §6.4

### 5.1 Test Limits

For the GSM Cell band the Effective Radiated Power (ERP) of mobile transmitters was not allowed to exceed 7 Watts. For the GSM band the Equivalent Isotropic Radiated Power (EIRP) was not allowed to exceed 2 Watts.

### 5.2 Test Procedure

The EUT does not include antenna during testing the Radiated RF power was calculated from the Antenna conducted power and Max. antenna gain (as declared by manufacturer)

The receiver reading was recorded for antenna conducted power and EIRP was calculated as follows:

$$EIRP = E_1 + G_{(dBi)}$$

$$ERP = E_1 + G_{(dBd)}$$

where,

**E<sub>1</sub>** is the receiver reading in dBm when measured at antenna port with average detector.

**G** is the gain of the transmitting antenna (as declared by manufacturer) in dBi or dBd.

$$G_{(dBi)} = G_{(dBd)} + 2.15$$

**5.3 Test Results**

The EUT met the radiated power requirements of FCC §24.232. The test results are located in Table 5-1. The maximum EIRP for the GSM 1900 band was **27.96** dBm. The maximum ERP for the GSM 850 band was **31.74** dBm.

*Table 5-1 Radiated RF Power*

EUT Mode	Channel	Freq.	Conducted Power Reading	Tx Antenna Gain	ERP	Output Power
		(MHz)	(dBm Avg.)	(dBd)	(dBm)	(mW)
<b>GSM 850</b>	128	824.20040080	<b>31.74</b>	0	<b>31.74</b>	1493
	190	836.54509018	31.52	0	31.52	1419
	251	848.90581162	31.32	0	31.32	1355

**Max ERP 31.74 dBm = 1493 mW**

Typical antenna gain is 7.11 dB. Thus the maximum ERP from above would be 31.34 + = 38.45 dBm (7 watts).

EUT Mode	Channel	Freq.	Conducted Power Reading	Tx Antenna Gain	EIRP	Output Power
		(GHz)	(dBm Avg.)	(dBi)	(dBm)	(mW)
<b>GSM 1900</b>	512	1.85016008	26.40	0	26.40	436
	662	1.88018802	27.24	0	27.24	529
	810	1.90981214	<b>27.96</b>	0	<b>27.96</b>	625

**Max EIRP 27.96 dBm = 625mW**

Typical antenna gain is 5.04 dB. Thus the maximum ERP from above would be 27.96 + 5.04 = 33.0 dBm (2 watts).

**6 MAXIMUM PERMISSIBLE EXPOSURE (MPE) CALCULATIONS**

**6.1 Test Limits**

The Radio frequency radiation exposure limits for FCC Rule § 1.1310 are listed in the table below.

	<b>Frequency Range (MHz)</b>	<b>Power Density Limit (mW/cm<sup>2</sup>)</b>
<b>Limits for Occupational/Controlled Exposures</b>	0.3-3.0	100
	3.0-30	900/ Frequency <sup>2</sup>
	30-300	1.0
	300-1500	Frequency/300
	1500-100,000	5.0
<b>Limits for General Population/Uncontrolled Exposure</b>	0.3-1.34	100
	1.34-30	180/Frequency <sup>2</sup>
	30-300	0.2
	300-1500	Frequency/1500
	1500-100,000	1.0

**6.2 Test Procedure**

The ERP and EIRP were measured in section 5. The radiated RF power was used to calculate the maximum RF exposure at a 20 cm distance using the formula:

$$\text{Maximum RF Exposure at 20cm} = (\text{EIRP in mW}) / (4\text{Pi}(20\text{cm})^2)$$

Where ERP was measured in section 5, a 2.15dB conversion factor was added to the reading to convert it to EIRP before applying the Maximum RF Exposure formula above. Once the Maximum RF Exposure calculations were complete the results were compared to the MPE limits above.

**6.3 Test Results**

The following calculations show the Maximum RF Exposure from the EUT at 20cm for GSM and GSM bands. Both bands are well below the limits for the general population described in the table above.

Antenna conducted power used as reference for calculation of MPE measurements.

Max .MPE<sub>GSM(800mhZ)</sub>: **31.74dBm** = 1493 mW

$$**\text{MPE}_{\text{GSM}} = \text{mW} / (4\text{Pi}(20\text{cm})^2) = 0.2969 \text{ mW/cm}^2$$

Max .MPE<sub>GSM(1900mhZ)</sub>: 27.96 dBm = **625.2** mW

$$**\text{MPE}_{\text{GSM}} = \text{mW} / (4\text{Pi}(20\text{cm})^2) = 0.12432 \text{ mW/cm}^2$$

**7 EMISSION LIMITATIONS, OCCUPIED BANDWIDTH**

CFR 47 §2.1049

RSS-132 §6.5; RSS-133 §6.3

**7.1 Test Limits**

The occupied bandwidth is the frequency bandwidth such that, below its lower and above its upper frequency limits, the mean powers radiated are each equal to 0.5 percent of the total mean power radiated by a given emission.

**7.2 Test Procedure**

In both GSM and GSM modes the antenna port of the EUT was connected to a spectrum analyzer using a calibrated coaxial cable and power divider. The EUT was placed maximum power using the support computer. The MODEM was set to force the EUT to its maximum power setting. The occupied bandwidth function of the analyzer was used to automatically generate the occupied bandwidth plots below.

EUT’s internal test mode was accesses and programmed by an external PC for operation.

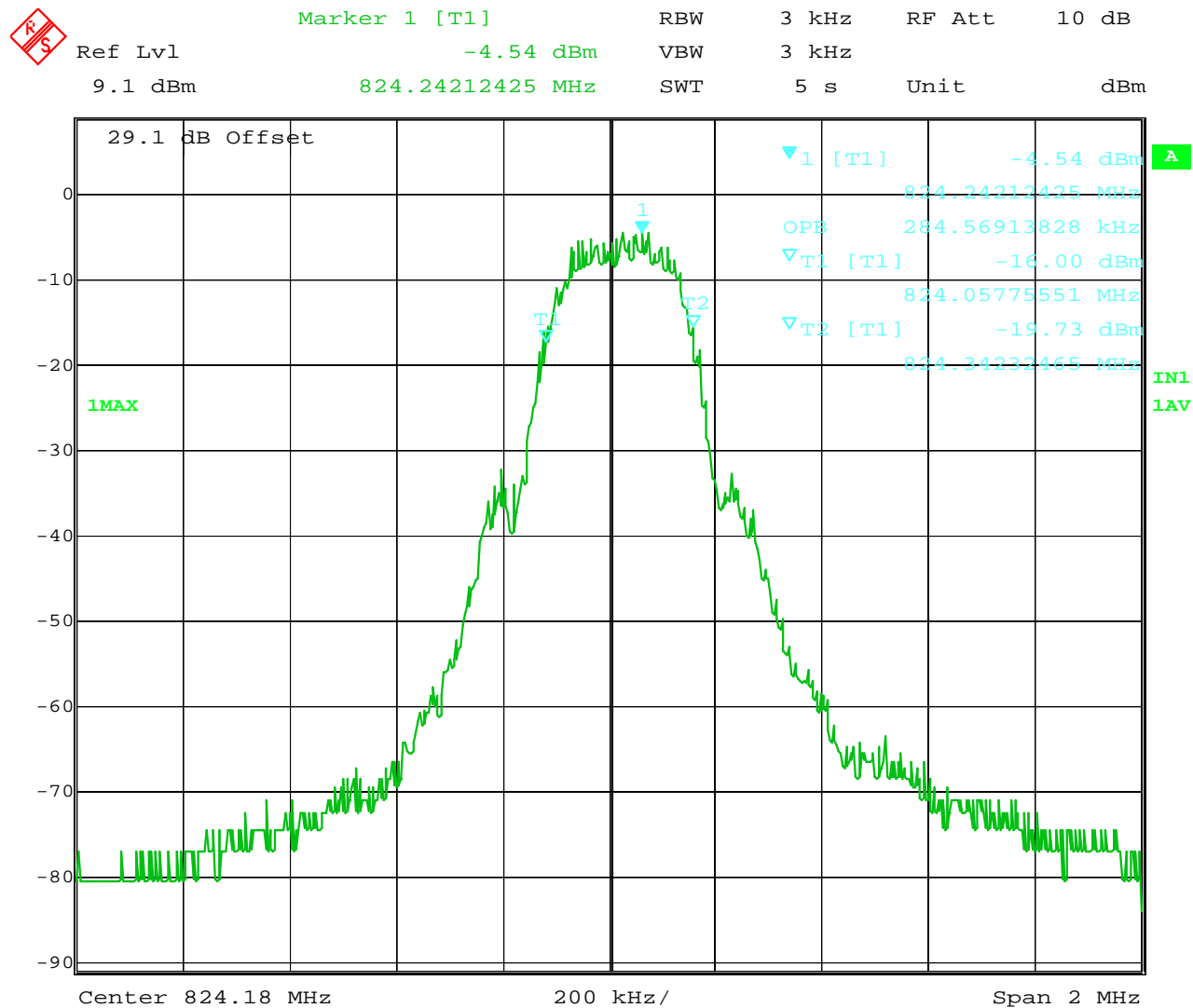
**7.3 Test Results**

The following is the occupied bandwidth data for the EUT.

*Table 7-1: Occupied bandwidth measurements*

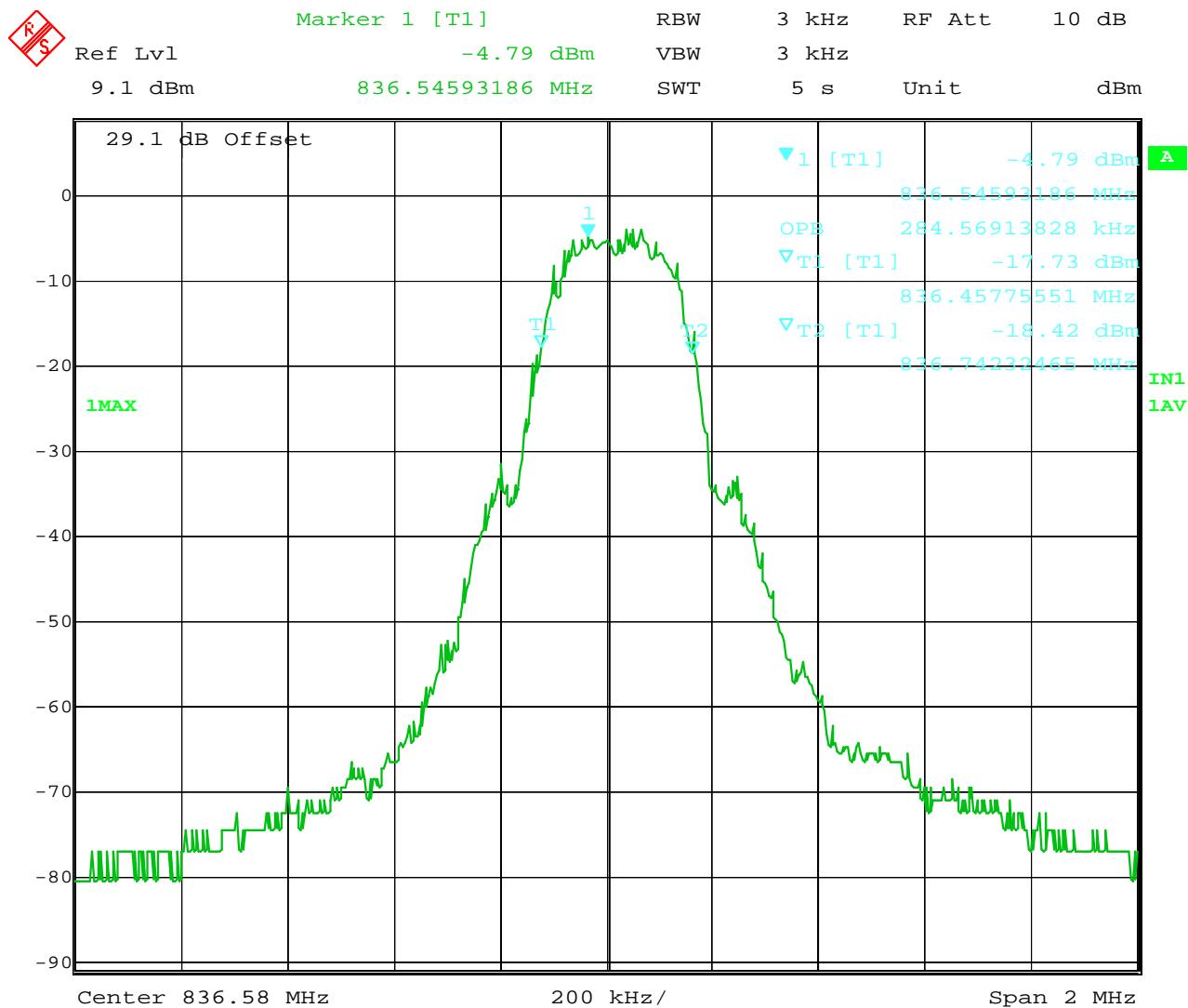
<b>Mode</b>	<b>Channel</b>	<b>Resolution Bandwidth</b>	<b>Video Bandwidth</b>	<b>Sweep time</b>	<b>Measured Bandwidth kHz</b>
GSM 850	128	3KHz	3KHz	5s	284.56
	190	3KHz	3KHz	5s	284.56
	251	3KHz	3KHz	5s	276.55
GSM 1900	512	3KHz	3KHz	5s	264.52
	662	3KHz	3KHz	5s	264.52
	810	3KHz	3KHz	5s	260.52

Figure 7-1: Occupied Bandwidth – GSM 128



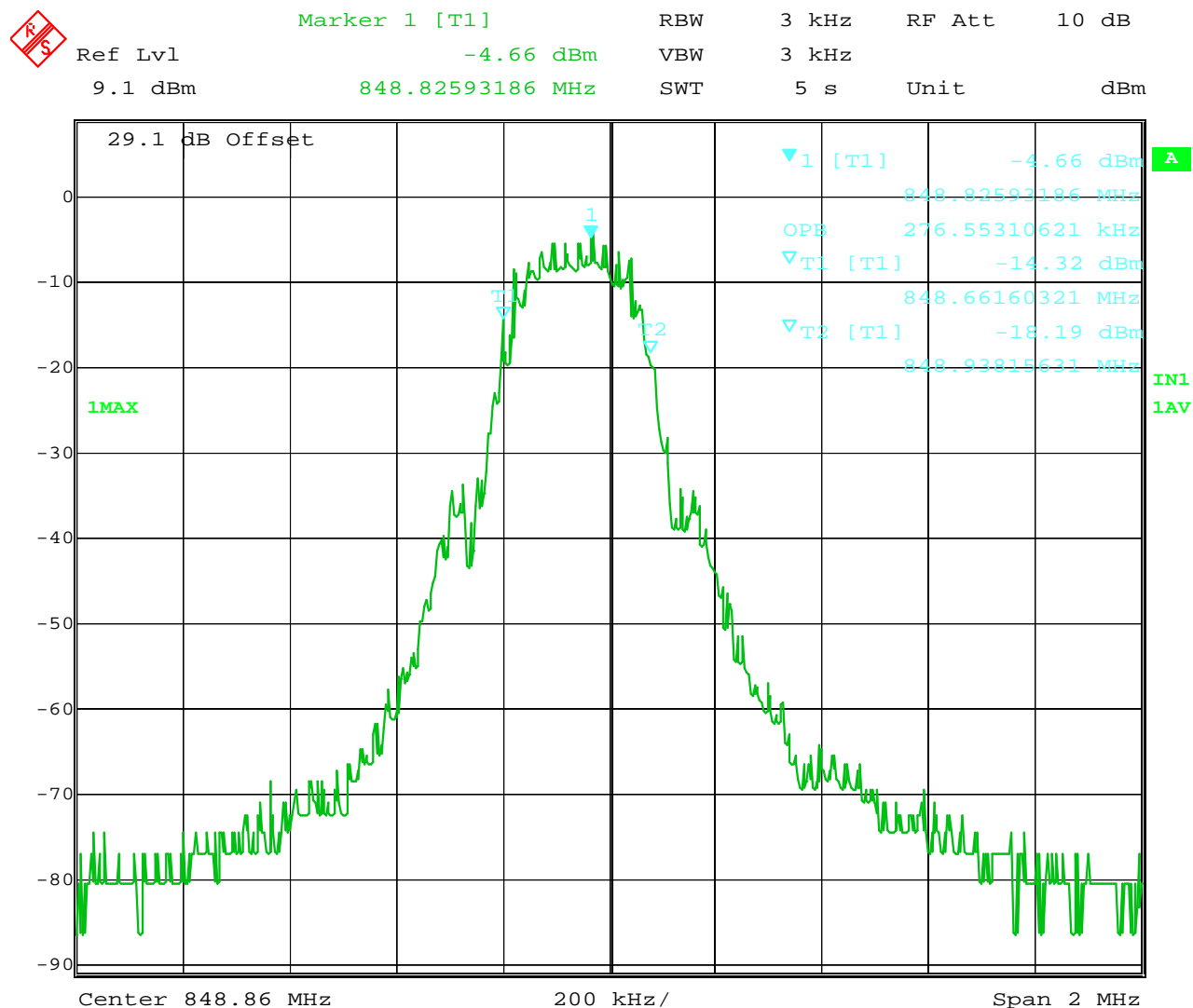
Date: 13.FEB.2006 14:12:23

Figure 7-2: Occupied Bandwidth – GSM 190



Date: 13.FEB.2006 14:14:10

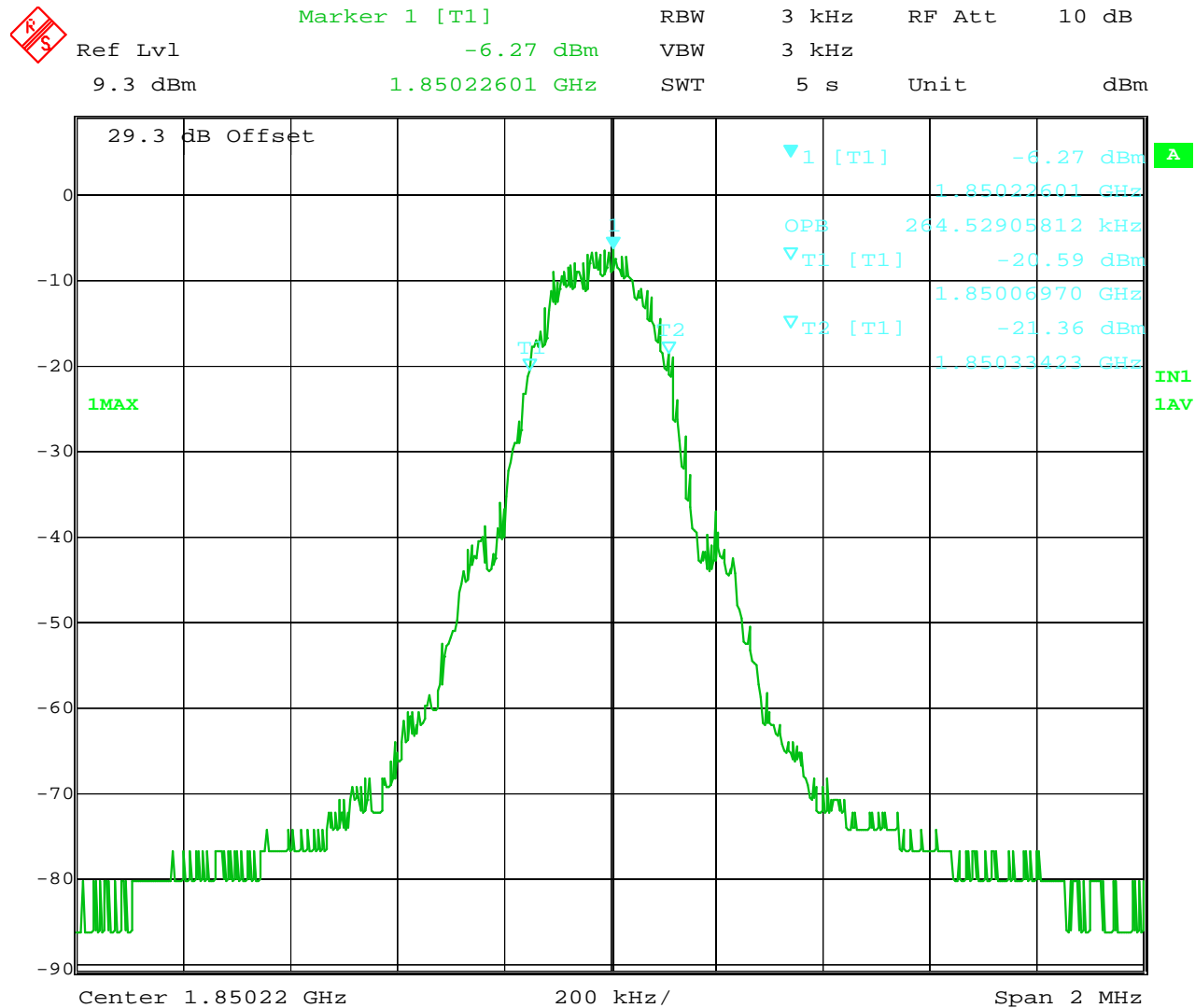
Figure 7-3: Occupied Bandwidth – GSM 251



Date: 13.FEB.2006 14:15:11

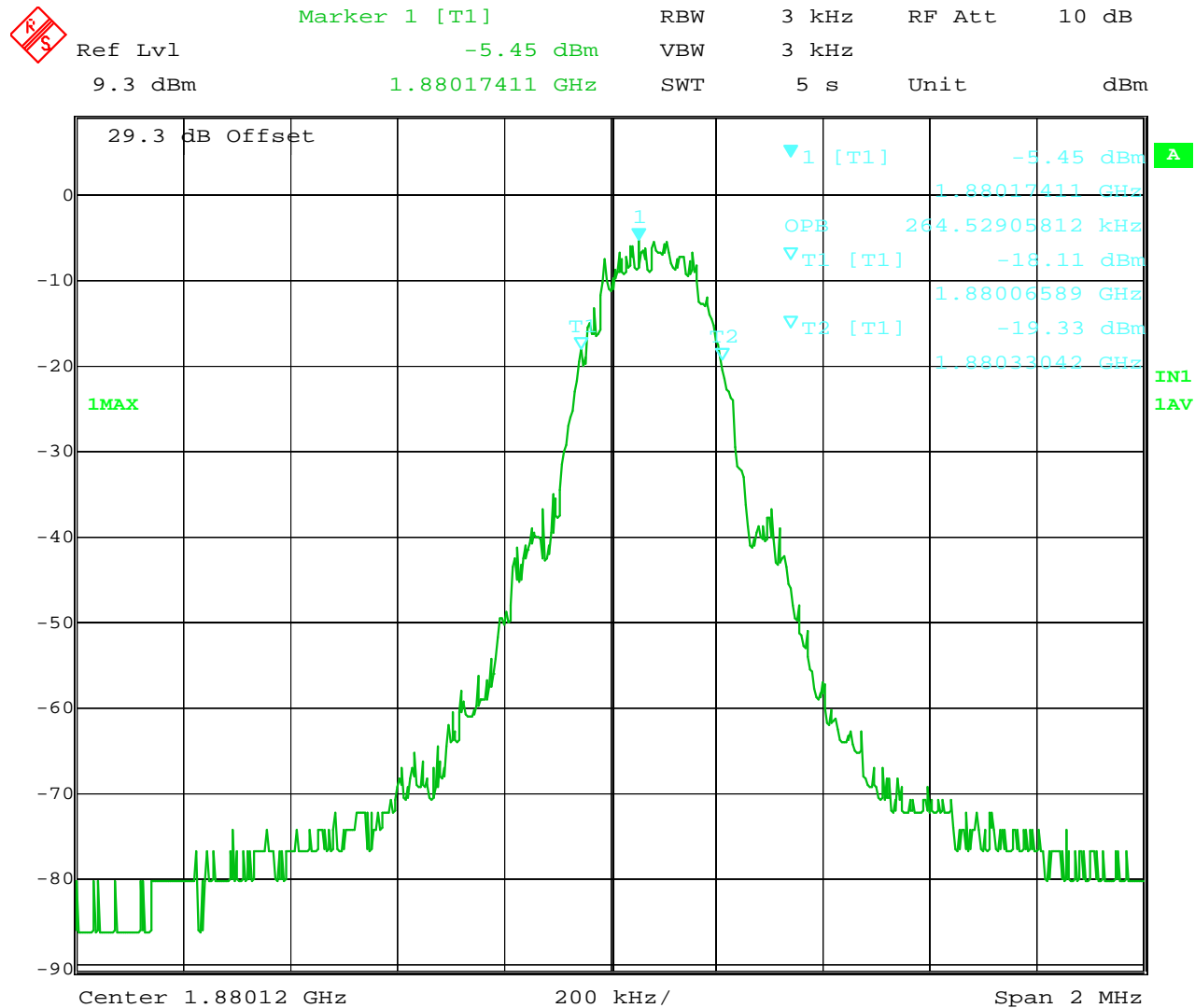


Figure 7-4: Occupied Bandwidth – GSM 512



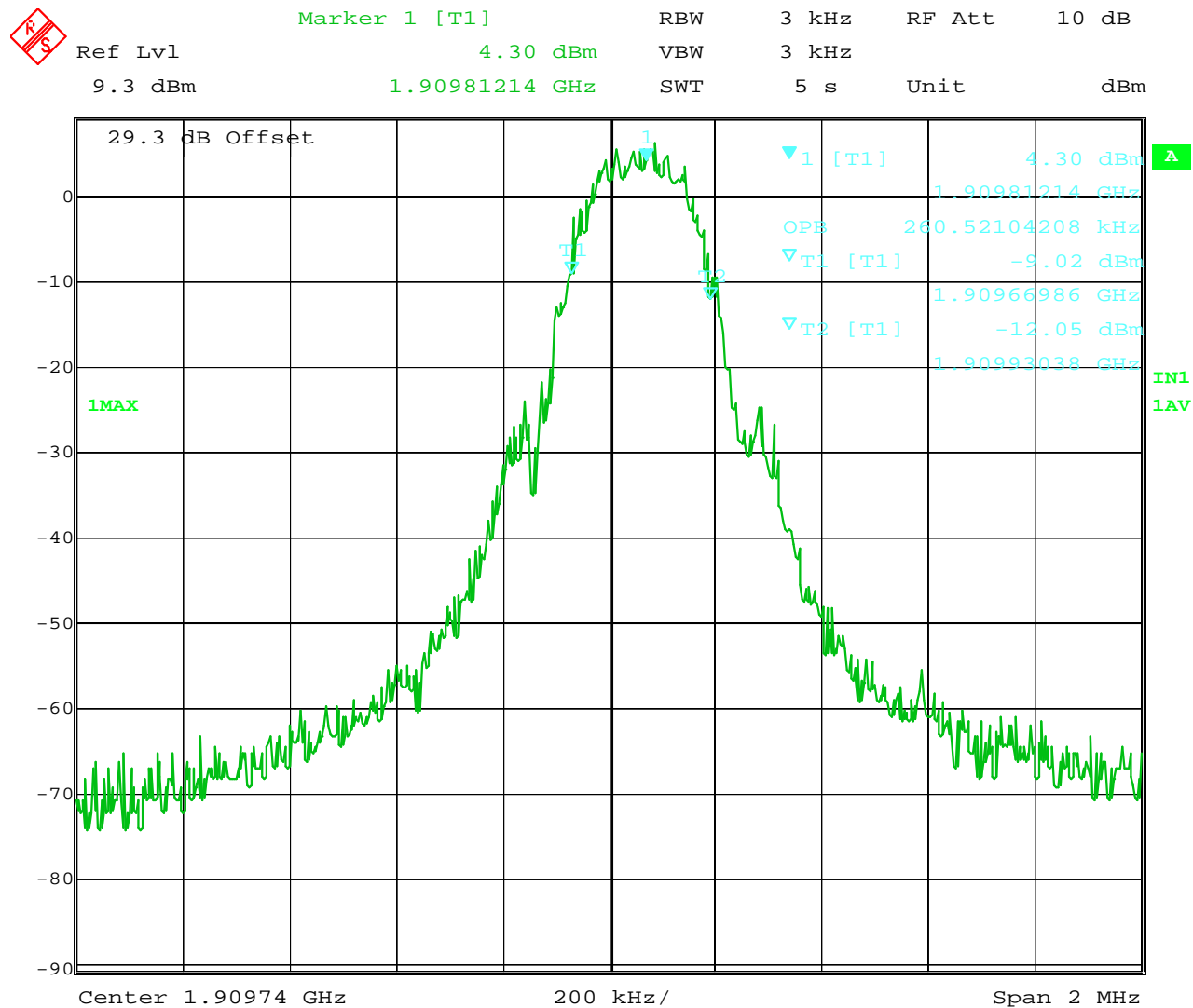
Date: 13.FEB.2006 14:10:54

Figure 7-5: Occupied Bandwidth – GSM 662



Date: 13.FEB.2006 14:09:58

Figure 7-6: Occupied Bandwidth – GSM 810



Date: 13.FEB.2006 14:08:33

## **8 OUT OF BAND EMISSION AT ANTENNA TERMINALS**

FCC §2.1049, FCC §2.1051, §22.917(a), FCC §24.238(a)

RSS-132 §6.5

RSS-133 §6.3

### **8.1 Test Limits**

The power of any emission outside of the authorized operating frequency ranges must be attenuated below the transmitting power (P) by a factor of at least  $43 + 10 \log(P)$  dB. Therefore, the test limit is defined by the following formula:

$$\text{Test Limit (dBm)} = \text{Tx Power (dBm)} - (43 + 10 \log(\text{Tx Power (Watts)})) = -13\text{dBm}$$

### **8.2 Test Procedure**

Compliance with these rules is based on the use of measurement instrumentation employing a resolution bandwidth of 100 kHz or greater for the GSM band and 1 MHz or greater in the GSM band. In the 1 MHz bands immediately outside and adjacent to the frequency block a resolution bandwidth of at least one percent of the emission bandwidth of the fundamental emission of the transmitter may be employed. A narrower resolution bandwidth is permitted in all cases to improve measurement accuracy provided the measured power is integrated over the full required measurement bandwidth (*i.e.* 100 kHz or 1 percent of emission bandwidth, as specified). The emission bandwidth is defined as the width of the signal between two points, one below the carrier center frequency and one above the carrier center frequency, outside of which all emissions are attenuated at least 26 dB below the transmitter power.

The RF output of the transceiver was connected to a spectrum analyzer through appropriate attenuation. The EUT was set to force its maximum power setting. The resolution bandwidth of the spectrum analyzer was set at 1 MHz. Sufficient scans were taken to show the out of band Emissions if any up to 10th harmonic.

The transmission was exercised in burst mode to generate maximum power, the power was averaged shall be averaged over the burst duration, during which its power value is at its maximum. The power measurement was averaged only over the durations of actual transmission. Gated Average detector was used during transmitted and out of band power measurements.

**8.3 Test Results**

The MODEM met the out of band emission at antenna terminal requirements.

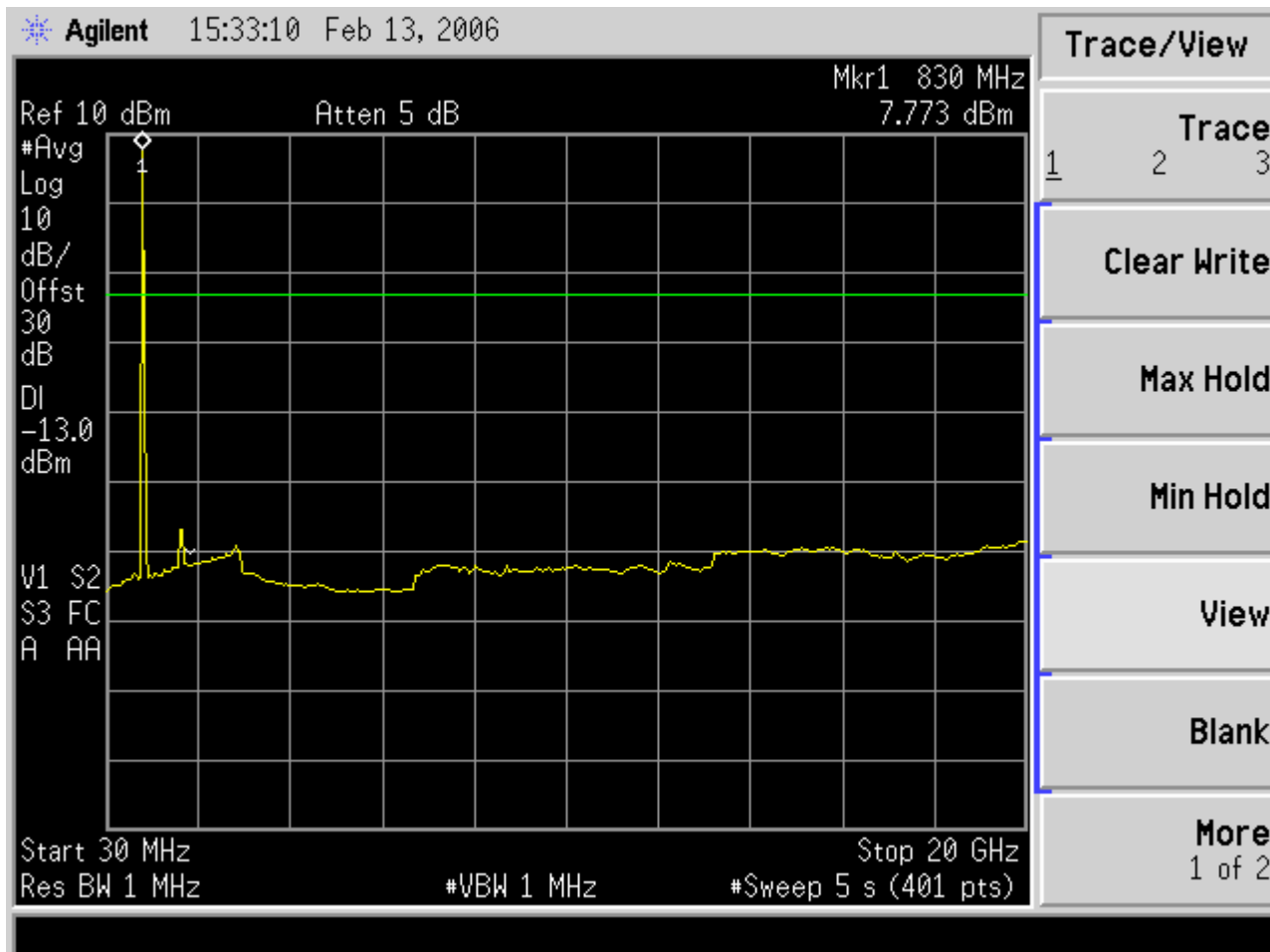
*Table 8-1: Summary of test result locations*

Location	Mode (Band)	Channel	Description
Figure 8-1	GSM 850	128, 190, 251	Conducted spurious emissions, 30MHz to 10 GHz
Figure 8-2	GSM 850	128, 190, 251	Zoom Graph of the Carrier Frequencies
Figure 8-3	GSM 1900	512, 662, 810	Conducted spurious emissions, 30MHz to 10 GHz
Figure 8-4	GSM 1900	512, 662, 810	Zoom Graph of the Carrier Frequencies
Figure 8-5	GSM 850	128	Emissions within 1 MHz of band edge
Figure 8-6	GSM 850	251	Emissions within 1 MHz of band edge
Figure 8-7	GSM 1900	512	Emissions within 1 MHz of band edge
Figure 8-8	GSM 1900	810	Emissions within 1 MHz of band edge

**NOTE:** Figures 8-1 and 8-2 contain plots that start at 30 MHz and stop at 7 GHz.

The harmonics are shown only up to 7 GHz. Harmonics above 7GHz were equal or less than the measuring receiver's noise floor.

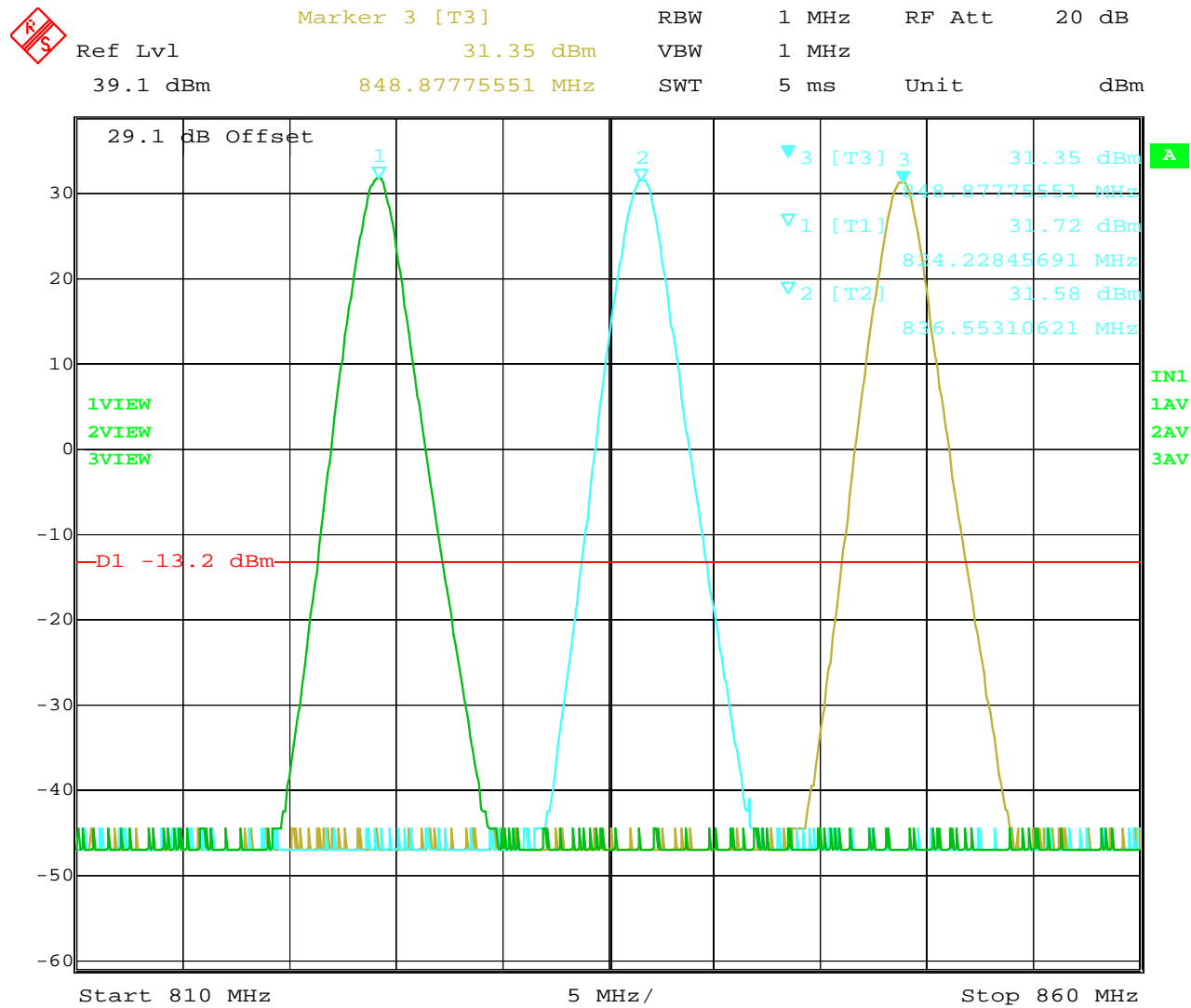
Figure 8-1: Out of band emissions at antenna terminals – GSM 850 Channels 128, 190, 251



Evaluation For: Enfora  
 Model No: MLG0208

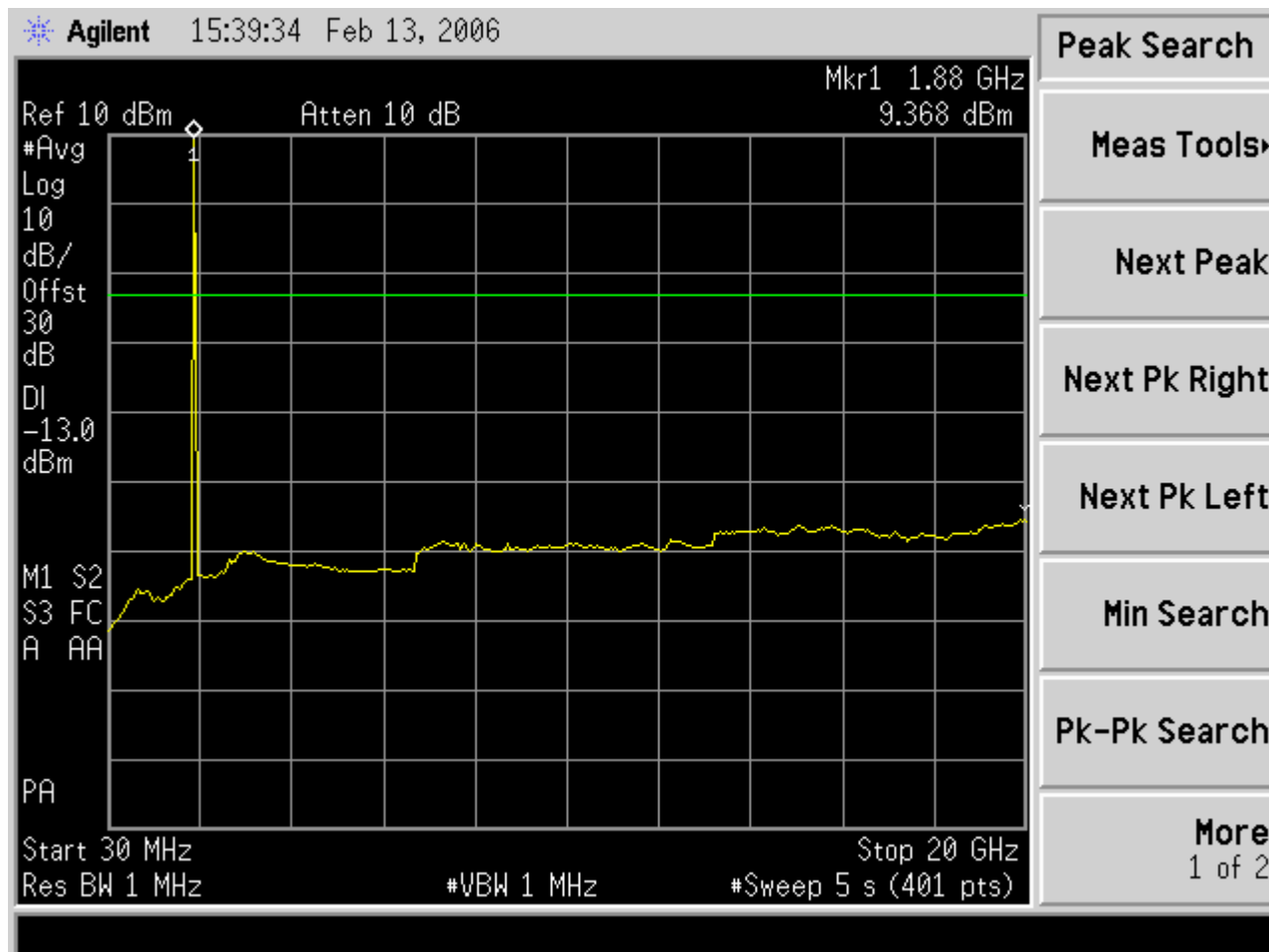
FCC ID: MIVGSM0208

Figure 8-2: Out of band emissions at antenna terminals – GSM 850 Channels 128, 190, 251  
 (Zoomed Around Carrier Frequencies)



Date: 13.FEB.2006 15:14:59

Figure 8-3: Out of band emissions at antenna terminals – GSM 1900 Channels 512, 662, 810

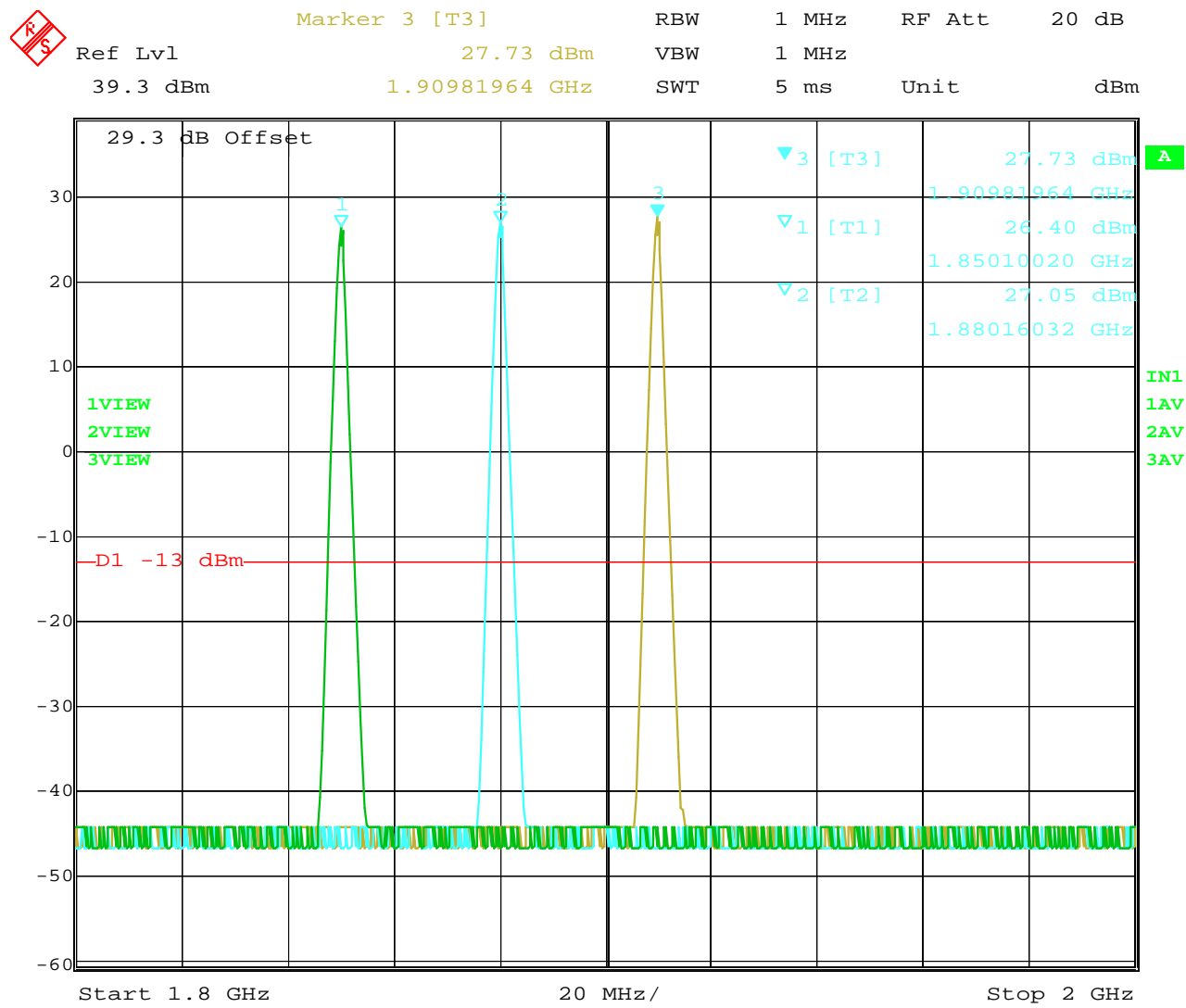




Evaluation For: Enfora  
Model No: MLG0208

FCC ID: MIVGSM0208

Figure 8-4: Out of band emissions at antenna terminals – GSM 1900 Channels 512, 662, 810 (Zoomed In on Carrier Frequencies)



Date: 13.FEB.2006 15:11:39





Figure 8-7: Emissions within 1 MHz of band edge, GSM 1900 Lower Band Edge

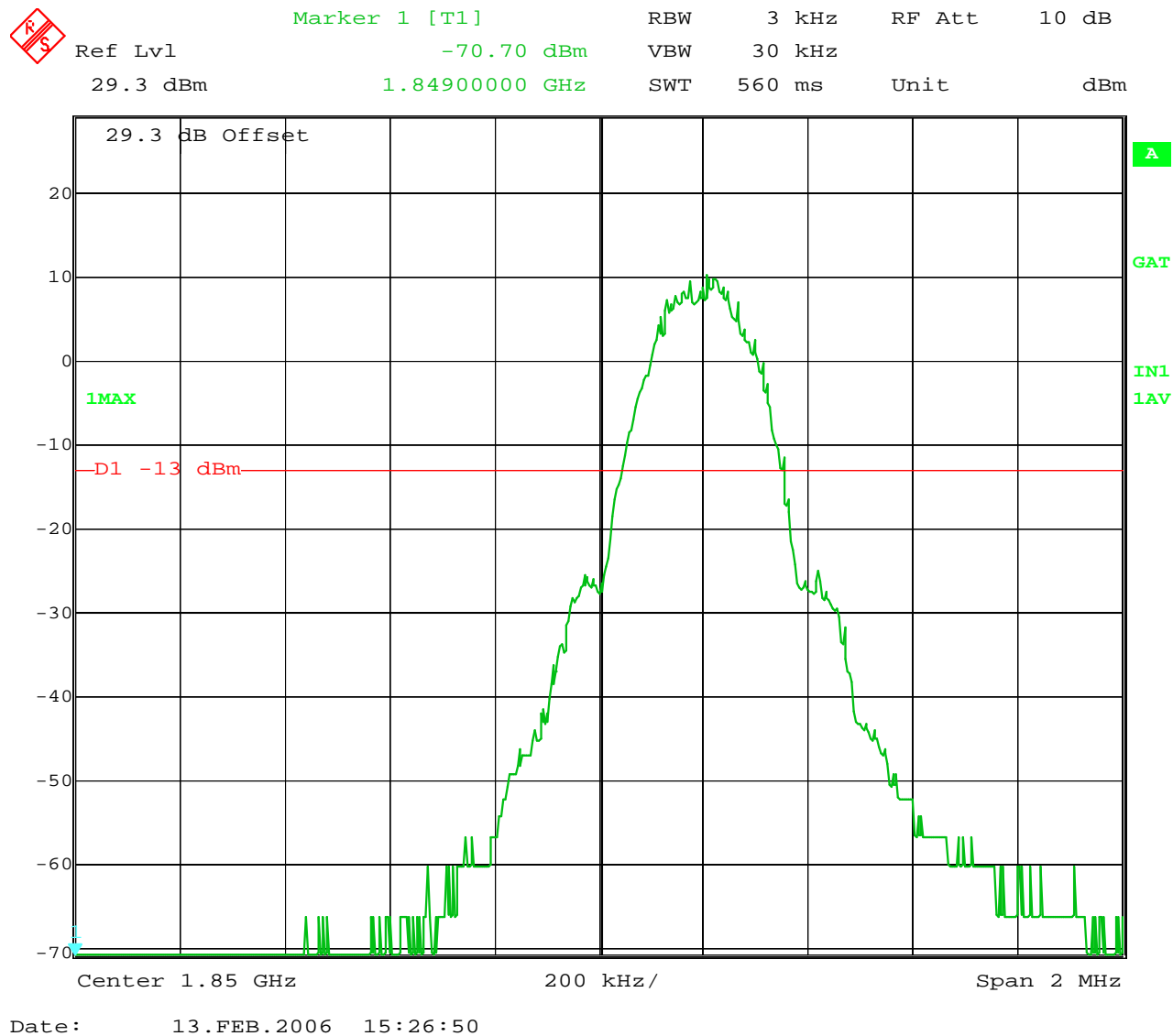


Figure 8-8: Emissions within 1 MHz of band edge, GSM 1900 Upper Band Edge

## 9 FIELD STRENGTH OF SPURIOUS RADIATION

FCC §2.1053; FCC §22.917; FCC §24.238

RSS-132 §6.6

### 9.1 Test Limits

The power of any emission outside of the authorized operating frequency ranges must be attenuated below the transmitting power (P) by a factor of at least  $43 + 10 \log(P)$  dB. Therefore, the test limit is defined by the following formula:

$$\text{Test Limit (dBm)} = \text{Tx Power (dBm)} - (43 + 10 \log (\text{Tx Power (Watts)})) = -13\text{dBm}$$

### 9.2 Test Procedure

The EUT was placed on a non-conductive turntable. The measurement antenna was placed at a distance of 3 meters from the EUT. The EUT was set to force its maximum power setting. During the tests, the antenna height and EUT azimuth were varied in order to identify the maximum level of emissions from the EUT.

The frequency range up to tenth harmonic was investigated for each of three fundamental frequencies (low, middle, and high channels) in each operating band. Once spurious emissions were identified, the power of the emission was determined using the substitution method described in TIA-603-B section 2.2.12 (Radiated Spurious Emissions).

The spurious emissions attenuation was calculated as the difference between radiated power at the fundamental frequency and at the spurious emissions frequency.

The antenna port was terminated with non-radiating 50 Ohm termination during the test.

### 9.3 Test Results

The EUT met the field strength of spurious radiation requirements of FCC §2.1053, FCC §22.917, and FCC §24.238. See Table 9-1 for measured radiated spurious emission power for emissions within 20 dB of the limit. All other emissions not reported are at least 20dB below the limit.

*Table 9-1: Field Strength of Spurious Radiation Substitution Measurements*

EUT Mode	Frequency (GHz)	Polarity	Device Reading (dBuV/m)	Sub Reading (dBuV/m)	Cable Loss (dB)	Tx Antenna Gain (dBi)	Signal Generator Output (dBm)	EIRP (dBm)
GSM 850 Channel 128	1610.32	V	62.101	101.658	2.234	9.822	0	-31.969
	4810.78	V	72.571	96.679	4.251	11.403	0	-16.956
	1639.39	H	63.86	101.962	2.44	9.561	0	-30.981
	2479.6	H	68.942	102.375	3.006	9.972	0	-26.467
	4812.49	H	73.933	99.751	4.252	10.46	0	-19.61

EUT Mode	Frequency (GHz)	Polarity	Device Reading (dBuV/m)	Sub Reading (dBuV/m)	Cable Loss (dB)	Tx Antenna Gain (dBi)	Signal Generator Output (dBm)	EIRP (dBm)
GSM 850 Channel 190	1662.41	V	62.419	100.658	2.458	9.822	0	-30.875
	2536.05	V	68.247	98.777	3.04	10.452	0	-23.118
	1660.08	H	62.873	100.934	2.358	9.604	0	-30.815
	2501.44	H	68.486	102.375	3.006	9.972	0	-26.923

EUT Mode	Frequency (GHz)	Polarity	Device Reading (dBuV/m)	Sub Reading (dBuV/m)	Cable Loss (dB)	Tx Antenna Gain (dBi)	Signal Generator Output (dBm)	EIRP (dBm)
GSM 850 Channel 251	1697.94	V	62.663	101.219	2.485	10.086	0	-30.955
	2547.42	V	69.144	100.579	3.047	10.434	0	-24.048
	3395.48	V	69.285	99.804	3.558	12.378	0	-21.699
	1688.25	H	63.476	100.51	2.478	9.653	0	-29.859
	2542.84	H	68.446	101.799	3.044	10.058	0	-26.339
	3388.63	H	70.15	102.871	3.555	10.946	0	-25.33

EUT Mode	Frequency (GHz)	Polarity	Device Reading (dBuV/m)	Sub Reading (dBuV/m)	Cable Loss (dB)	Tx Antenna Gain (dBi)	Signal Generator Output (dBm)	EIRP (dBm)
GSM 1900 Channel 512	3700.52	V	70.25	97.375	3.76	11.896	0	-18.989
	3700.05	H	71.019	101.974	3.76	10.643	0	-24.072
	5550.09	H	73.241	101.498	4.569	11.497	0	-21.329

EUT Mode	Frequency (GHz)	Polarity	Device Reading (dBuV/m)	Sub Reading (dBuV/m)	Cable Loss (dB)	Tx Antenna Gain (dBi)	Signal Generator Output (dBm)	EIRP (dBm)
GSM 1900 Channel 662	3760.52	V	70.369	97.72	3.794	11.541	0	-19.604
	3759.57	H	70.208	100.985	3.794	10.492	0	-24.079
	5639.91	H	73.984	101.629	4.601	11.564	0	-20.682

EUT Mode	Frequency (GHz)	Polarity	Device Reading (dBuV/m)	Sub Reading (dBuV/m)	Cable Loss (dB)	Tx Antenna Gain (dBi)	Signal Generator Output (dBm)	EIRP (dBm)
GSM 1900 Channel 810	3819.53	V	70.123	100.102	3.828	11.191	0	-22.616
	3818.7	H	71.48	102.37	3.827	10.342	0	-24.375
	5728.79	H	73.909	102.056	4.634	11.63	0	-21.151

**10 POWER LINE CONDUCTED EMISSIONS**

FCC §15.107, FCC §15.207

IC ES-003

**10.1 Test Limits**

Table 10-1 lists the conducted emission limits for both class A and B devices.

*Table 10-1 Conducted Emission Limit for FCC §15.207(a)*

Frequency Range (MHz)	Class A Limits		Class B Limits	
	FCC Part 15.107(a) Quasi Peak Limit (dBuV)	FCC Part 15.107(a) Average Limit (dBuV)	FCC Part 15.107(a) Quasi Peak Limit (dBuV)	FCC Part 15.107(a) Average Limit (dBuV)
0.15 – 0.5	79	66	66 to 56	56 to 46
0.5 – 5.0	73	60	56	46
5.0 - 30	73	60	60	50

**10.2 Test Procedure**

Measurements are carried out using quasi-peak and average detector receivers in accordance with CISPR 16. An AMN is required to provide defined impedance at high frequencies across the power feed at the point of measurement of terminal voltage and also to provide isolation of the circuit under test from the ambient noise on the power lines. An AMN as defined in CISPR 16 shall be used.

The EUT is located so that the distance between the boundary of the EUT and the closest surface of the AMN is 0.8m.

Where a flexible mains cord is provided by the manufacturer, this shall be 1m long or if in excess of 1m, the excess cable is folded back and forth as far as possible so as to form a bundle not exceeding 0.4m in length.

The EUT is arranged and connected with cables terminated in accordance with the product specification.

Conducted disturbance is measured between the phase lead and the reference ground, and between the neutral lead and the reference ground. Both measured values are reported.

The EUT, where intended for tabletop use, is placed on a table whose top is 0.8m above the ground plane. A vertical, metal reference plane is placed 0.4m from the EUT. The vertical metal reference-plane is at least 2m by 2m. The EUT shall be kept at least 0.8m from any other metal surface or other ground plane not being part of the EUT. The table is constructed of non-conductive materials. Its dimensions are 1m by 1.5m, but may be extended for larger EUT.

Floor standing EUTs are placed on a horizontal metal ground plane and isolated from the ground plane by 3 to 12 mm of insulating material. The metal ground plane extends at least 0.5m beyond the boundaries of the EUT and has minimum dimensions of 2m by 2m.

Equipment setup for conducted disturbance tests followed the guidelines of ANSI C63.4: 1992.



### 10.3 Test Results

The EUT met the power line conducted emission requirements of FCC §15.107 and §15.207. The test results are located in Figure 10-1. The graphical data, measured with peak detection, was all below the class B quasi-peak and average limits.

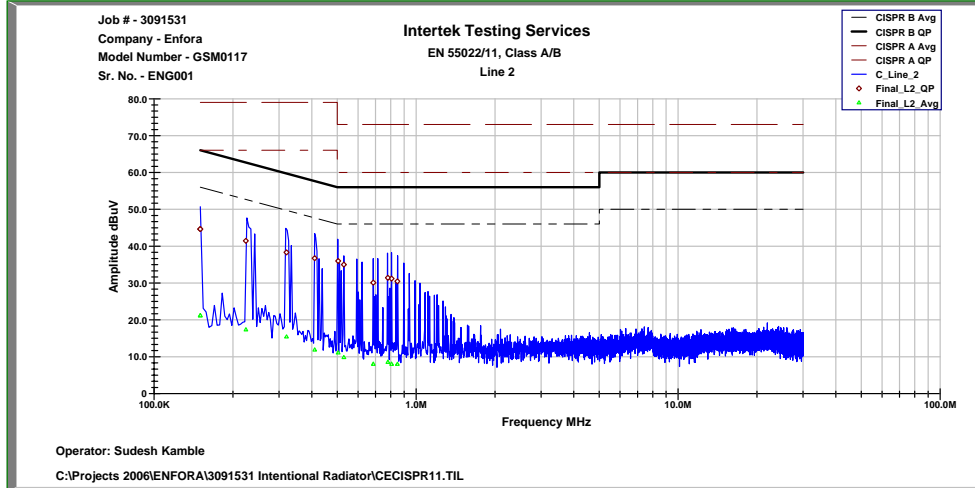
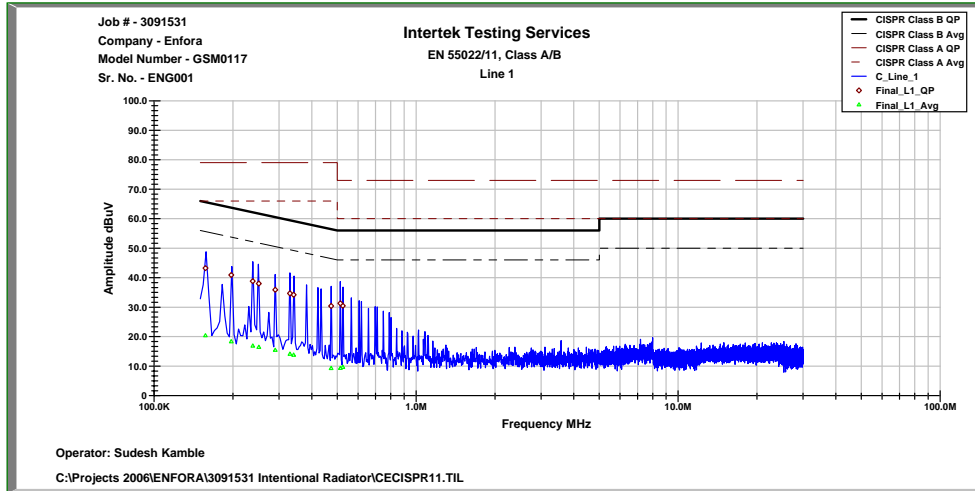


Figure 10-1: FCC §15.107 and §15.207 power line conducted emissions (Lines 1 and 2)

Line 1

Frequency MHz	L1 QP dBµV	L1 Avg dBµV	QP Class B Limit dBµV	QP Margin dB	Avg. Class B Limit dBµV	Avg. Margin dB
0.525	30.458	9.651	56.000	-25.542	46.000	-36.349
0.514	31.273	9.304	56.000	-24.727	46.000	-36.696
0.474	30.375	9.273	56.743	-26.368	46.743	-37.470
0.341	34.174	13.775	60.543	-26.369	50.543	-36.768
0.33	34.648	14.104	60.857	-26.209	50.857	-36.753
0.29	35.860	15.436	62.000	-26.140	52.000	-36.564
0.251	38.000	16.446	63.114	-25.115	53.114	-36.669
0.238	38.814	16.885	63.486	-24.671	53.486	-36.601
0.197	40.888	18.355	64.657	-23.769	54.657	-36.302
0.157	43.228	20.372	65.800	-22.572	55.800	-35.428

Line 2

Frequency MHz	L2 QP dBµV	L2 Avg dBµV	QP Class B Limit dBµV	QP Margin dB	Avg. Class B Limit dBµV	Avg. Margin dB
0.848	30.442	8.009	56.000	-25.558	46.000	-37.991
0.806	31.194	8.022	56.000	-24.806	46.000	-37.978
0.78	31.393	8.548	56.000	-24.607	46.000	-37.452
0.686	30.088	8.035	56.000	-25.912	46.000	-37.965
0.53	34.990	9.840	56.000	-21.010	46.000	-36.160
0.504	35.964	11.096	56.000	-20.036	46.000	-34.904
0.41	36.718	11.884	58.571	-21.853	48.571	-36.687
0.32	38.305	15.432	61.143	-22.838	51.143	-35.710
0.224	41.433	17.371	63.886	-22.453	53.886	-36.515
0.15	44.635	21.176	66.000	-21.365	56.000	-34.824

**11 RECEIVER SPURIOUS EMISSIONS**

FCC §15.109

IC ES-003, RSS-132 §6.6, RSS-133 §9

**11.1 Test Limits**

Table 11-1 lists the Class A and B limits for spurious using quasi-peak detection below 1GHz and average detection above 1GHz.

*Table 11-1 Radiated Emission Limit for FCC §15.109*

Frequency (MHz)	3 Meter Limits		10 Meter Limits	
	Class A	Class B	Class A	Class B
	Quasi-Peak limits dB(µV/m)	Quasi-Peak limits, dB(µV/m)	Quasi-Peak limits dB(µV/m)	Quasi-Peak limits, dB(µV/m)
30 to 88	49.6	40	39.1	29.5
88 to 216	54.0	43.5	43.5	33.1
216 to 960	56.9	46.0	46.4	35.6
960 and up	60.0	54.0	49.5	43.5

**11.2 Test Procedure**

Measurements are made over the frequency range of 30 MHz to five times the highest frequency operating within the device. The measuring receiver meets the requirements of Section One of CISPR 16 and the measuring antenna correlates to a balanced dipole. From 30 to 1000 MHz, a quasi-peak detector was used for measurement. Above 1000 MHz, average measurements were performed.

Measurements of the radiated field are made with the antenna located at a distance of 3 meters from the EUT. If the field-strength measurements at 3m cannot be made because of high ambient noise level or for other reasons, measurements may be made at a closer distance, for example 1m. An inverse proportionality factor of 20 dB per decade should be used to normalize the measured data to the specified distance for determining compliance.

The antenna is adjusted between 1m and 4m in height above the ground plane for maximum meter reading at each test frequency.

The antenna-to-EUT azimuth is varied during the measurement to find the maximum field-strength readings.

The antenna-to-EUT polarization (horizontal and vertical) is varied during the measurements to find the maximum field-strength readings.

The EUT, where intended for tabletop use, is placed on a table whose top is 0.8m above the ground plane. The table is constructed of non-conductive materials. Its dimensions are 1m by 1.5m, but may be extended for larger EUT.

Equipment setup for radiated disturbance tests followed the guidelines of ANSI C63.4: 1992.

The transmitter was turned off during the test by accessing the EUT's internal test mode by an external PC.

**11.3 Test Results**

The EUT was **compliant** with the radiated disturbance requirements of FCC §15.109 for a **class B** device. The maximized quasi peak and average data can be found in Figure 11-1.

*Figure 11-1 FCC §15.109 Maximized Quasi Peak and Average Emissions (Max Emissions sorted by Margin)*

Polarity	Frequency MHz	Ant Height cm	Azimuth deg.	QP dBµV /m	Limit dBµV /m	Margin dB
H	967.73	318.00	176.00	36.85	53.98	-17.13
H	957.43	382.00	131.00	36.86	46.02	-9.16
H	557.19	138.00	297.00	31.79	46.02	-14.23
H	115.18	392.00	324.00	23.01	43.52	-20.51
H	87.63	382.00	268.00	20.05	40.00	-19.95
H	35.97	257.00	179.00	32.73	40.00	-7.27
V	35.98	111.00	288.00	36.48	40.00	-3.52
V	47.96	116.00	294.00	35.52	40.00	-4.48
V	67.31	255.00	140.00	22.42	40.00	-17.58
V	109.34	329.00	120.00	21.77	43.52	-21.75
V	214.15	328.00	261.00	21.26	43.52	-22.26
V	271.86	132.00	55.00	23.90	46.02	-22.12
V	926.36	317.00	98.00	37.62	46.02	-8.40

\*\* The max clock frequency is 1900 MHz (transmit) and the max emissions reported are only up to 5<sup>th</sup> harmonic of the highest frequency. The pre-scan determined that there are no emissions above 1 GHz in receive mode and the noise floor of measurement is at least 6 dB below the limit.

**12 FREQUENCY STABILITY VS TEMPERATURE**

FCC §2.1055, FCC §22.355, FCC §24.235

RSS-132 §6.3 and RSS-133 §7

**12.1 Test Limits**

The frequency tolerance shall be maintained within:  $\pm 2.5$ ppm (or 0.000025MHz)

**12.2 Test Procedure**

The transmitter output was connected to a calibrated coaxial cable. The EUT was set to its maximum power setting. The EUT was placed into a call and the transmitter output was read off the frequency counter. The power output at the transmitter antenna port was determined by adding the value of the cable insertion loss.

The equipment under test was powered and the RF output was connected to a Base Station Simulator. The Base Station Simulator was set to force the EUT to its maximum power setting. The EUT was placed inside the temperature chamber. The RF output cable exited the chamber through an opening made for that purpose. After the temperature stabilized for approximately 30 minutes, the frequency error was read from the Base Station Simulator.

**12.3 Test Results**

The EUT met the frequency stability requirements of FCC §2.1055, FCC §22.355 and FCC §24.235. The test results are located in Table 12-1.

*Table 12-1: Frequency stability vs. Temperature*

Frequency Stability** Vs. Temperature (Hz)						
Temp. (Celcius)	GSM 850 Channel #			GSM 1900 Channel #		
	128	190	251	512	662	810
60	-17	-18	-31	-41	+33	+66
50	-27	-26	-20	-38	-41	-40
40	-23	-24	-22	-32	-40	-42
30	-31	-28	-26	-46	-52	-56
20	-13	-32	-21	-62	-27	-55
10	-22	-16	-18	+25	+40	-28
0	-18	-19	+16	-26	-36	-39
-10	-20	-19	-22	-30	-28	-28
-20	-23	-21	-27	-35	+41	-38
-30	-26	-23	-25	-44	-45	-43

\*\* Noted as deviation from the reference frequency (absolute).

**13 FREQUENCY STABILITY VS VOLTAGE**

FCC §2.1055, FCC §22.355, FCC §24.235

**13.1 Test Limits**

The frequency tolerance shall be maintained within:  $\pm 2.5$ ppm (or 0.000025MHz)

**13.2 Test Procedure**

The AC supply of the test Jig was replaced with a variable output AC using Power supply adapter supplying power to the test jig. The EUT was set to force the EUT to its maximum power setting. The voltage was set to 115% of the nominal value and was then decreased to 85% of the nominal value. The output frequency was recorded for each input voltage.

For DC supply voltage measurement, The DC supply to the EUT was connected to a variable output DC power supply. The Base Station Simulator was set to force the EUT to its maximum power setting. The voltage was set to 115% of the nominal value and was then decreased to 85% of the nominal value. The output frequency was recorded for each input voltage.

**13.3 Test Results**

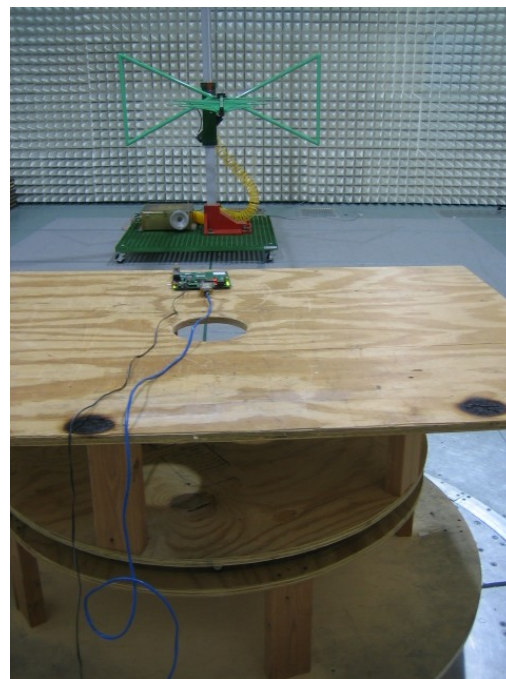
The EUT met the frequency stability requirements of FCC §2.1055, FCC §22.355, and §24.235. The test results are located in Table 13-1.

*Table 13-1: Frequency stability vs. input voltage*

Frequency Stability Vs. Voltage						
Voltage (Vdc)	GSM 850 Channel #			GSM 1900 Channel #		
	128	190	251	512	662	810
4.37	-30	-27	-23	-56	-55	-51
3.8	-13	-32	-21	-62	-27	-55
3.23	+65	+42	-20	-33	+90	+106

## 14 TEST SET UP PICTURES

### 14.1 Radiated Emissions





### 14.2 AC Line Conducted Emissions





### 15 EUT PICTURES

