

## CERTIFICATE OF COMPLIANCE SAR EVALUATION

<p><b><u>Test Lab:</u></b></p> <p><b>CELLTECH RESEARCH INC.</b> Testing and Engineering Lab 1955 Moss Court Kelowna, B.C. Canada V1Y 9L3 Phone: 250 - 860-3130 Fax: 250 - 860-3110 Toll Free: 1-877-545-6287 e-mail: <a href="mailto:celltech@globuswireless.com">celltech@globuswireless.com</a> web site: <a href="http://www.globuswireless.com">www.globuswireless.com</a></p>	<p><b><u>Applicant Information:</u></b></p> <p><b>NEXTCELL INC.</b> 651 East 18<sup>th</sup> Street Plano, TX 75074 Attn: Mr. Durward Rutledge, P.E. Vice President of Product Integrity Tel.: 972-633-4441 Fax: 972-633-4444</p>
--	---

<b>FCC ID:</b>	<b>MIVCDP06PS</b>
<b>Model:</b>	<b>POCKETSPIDER<sup>®</sup></b>
<b>Equipment Type:</b>	<b>CDPD Modem Module for Compact Flash Slot</b>
<b>Equipment Classification:</b>	<b>Licensed Non-Broadcast Station Transmitter (TNB)</b>
<b>Modulation(s):</b>	<b>TDMA</b>
<b>Tx Frequency Range:</b>	<b>824.04 - 849.97 MHz</b>
<b>Rx Frequency Range:</b>	<b>869.04 - 894.97 MHz</b>
<b>Max. RF Output Power:</b>	<b>0.6 Watts (ERP)</b>
<b>FCC Rule Part(s):</b>	<b>2.1093; ET Docket 96.326</b>

This wireless mobile and/or portable device has been shown to be compliant for localized specific absorption rate (SAR) for uncontrolled environment/general exposure limits specified in ANSI/IEEE Std. C95.1-1992 and had been tested in accordance with the measurement procedures specified in ANSI/IEEE Std. C95.3-1999. (See test report).

I attest to the accuracy of data. All measurements were performed by me or were made under my supervision and are correct to the best of my knowledge and belief. I assume full responsibility for the completeness of these measurements and vouch for the qualifications of all persons taking them.

Celltech Research Inc. certifies that no party to this application has been denied FCC benefits pursuant to Section 5301 of the Anti-Drug Abuse Act of 1988, 21 U.S.C. 853(a).

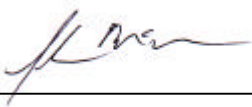

**Shawn McMillen**  
**General Manager**  
**Celltech Research Inc.**



## **TABLE OF CONTENTS**

1.0	<b>INTRODUCTION</b> .....	1
2.0	<b>DESCRIPTION OF EUT</b> .....	1
3.0	<b>SAR MEASUREMENT SYSTEM</b> .....	2
4.0	<b>MEASUREMENT SUMMARY</b> .....	
	Hand SAR.....	3
	Body SAR.....	4
5.0	<b>SAR LIMITS</b> .....	4
6.0	<b>DETAILS OF SAR EVALUATION</b> .....	5
7.0	<b>EVALUATION PROCEDURES</b> .....	6
8.0	<b>SYSTEM VALIDATION</b> .....	6
9.0	<b>SIMULATED EQUIVALENT TISSUES</b> .....	7
10.0	<b>TISSUE PARAMETERS</b> .....	7
11.0	<b>SYSTEM SPECIFICATIONS</b> .....	8
12.0	<b>TEST EQUIPMENT LIST</b> .....	9
13.0	<b>MEASUREMENT UNCERTAINTIES</b> .....	10
14.0	<b>REFERENCES</b> .....	11
	<b>APPENDIX A - SAR MEASUREMENT DATA</b> .....	12
	<b>APPENDIX B - DIPOLE VALIDATION</b> .....	13
	<b>APPENDIX C - PROBE CALIBRATION</b> .....	14
	<b>APPENDIX D - SAR TEST SETUP PHOTOGRAPHS</b> .....	15

## 1.0 INTRODUCTION

This measurement report shows compliance of the NEXTCELL INC. POCKETSPIDER<sup>®</sup> CDPD Modem Module for Compact Flash Slot with FCC Part 2.1093, ET Docket 96-326 Rules for mobile and portable devices. The test procedures, as described in American National Standards Institute C95.1 - 1992 (1), FCC OET Bulletin 65-1997 were employed. A description of the product and operating configuration, detailed summary of the test results, methodology and procedures used in the evaluation, equipment used, and the various provisions of the rules are included within this test report.

## 2.0 DESCRIPTION of Equipment Under Test (EUT)

<b>EUT Type</b>	CDPD Modem Module for Compact Flash Slot	<b>Equipment Class</b>	Licensed Non-Broadcast Station Transmitter (TNB)
<b>FCC ID</b>	MIVCDP06PS	<b>Model No.</b>	POCKETSPIDER <sup>®</sup>
<b>Tx Frequency Range (MHz)</b>	824.04 - 849.97	<b>S/N No.</b>	Pre-production
<b>Rx Frequency Range (MHz)</b>	869.04 - 894.97	<b>Max. RF Output Power</b>	0.6 Watts
<b>Power Supply</b>	3.7V 700mAH Li-ion	<b>Signal Modulation(s)</b>	GMSK
<b>Antenna Type</b>	Stubby	<b>Antenna Length</b>	43 mm



Fig. 1. Front of EUT



Fig. 2. Rear of EUT



Fig. 3. Top End of EUT



Fig. 4. Bottom End of EUT

### **3.0 SAR MEASUREMENT SYSTEM**

Celltech Research SAR measurement facility utilizes the Dosimetric Assessment System (DASY™) manufactured by Schmid & Partner Engineering AG (SPEAG™) of Zurich, Switzerland. The DASY system is comprised of the robot controller, computer, near-field probe, probe alignment sensor, and the generic twin phantom containing brain or muscle equivalent material (see Figure 6). The robot is a six-axis industrial robot performing precise movements to position the probe to the location (points) of maximum electromagnetic field (EMF). A cell controller system contains the power supply, robot controller, teach pendant (Joystick), and remote control, is used to drive the robot motors. The Staubli robot is connected to the cell controller to allow software manipulation of the robot. A data acquisition electronics (DAE) circuit performs the signal amplification, signal multiplexing, AD-conversion, offset measurements, mechanical surface detection, collision detection, etc. is connected to the Electro-optical coupler (EOC). The EOC performs the conversion from the optical into digital electric signal of the DAE and transfers data to the PC plug-in card. The DAE3 utilizes a highly sensitive electrometer-grade preamplifier with auto-zeroing, a channel and gain-switching multiplexer, a fast 16 bit AD-converter and a command decoder and control logic unit. Transmission to the PC-card is accomplished through an optical downlink for data and status information and an optical uplink for commands and clock lines. The mechanical probe-mounting device includes two different sensor systems for frontal and sidewise probe contacts. They are also used for mechanical surface detection and probe collision detection. The robot uses its own controller with a built in VME-bus computer.



Figure 5. DASY3 SAR Measurement System

#### 4.0 MEASUREMENT SUMMARY

The measurement results were obtained with the EUT tested in the conditions described in this report. Detailed measurement data and plots showing the maximum SAR location of the EUT are reported in Appendix A.

#### HAND SAR Measurement Results

Freq. (MHz)	Chan.	Mode Tested	Max. Conducted Pwr. (dBm)	EUT Position	Phantom Section	Separation Distance (cm)	SAR (w/kg)
824.04	991	TDMA	26.5	Front Side	Flat	0.0	2.30
836.49	383	TDMA	26.7	Front Side	Flat	0.0	1.41
848.97	799	TDMA	25.4	Front Side	Flat	0.0	1.84
824.04	991	TDMA	26.5	Back Side	Flat	0.0	1.17
836.49	383	TDMA	26.7	Back Side	Flat	0.0	0.830
848.97	799	TDMA	25.4	Back Side	Flat	0.0	0.968
824.04	991	TDMA	26.5	Antenna Side	Flat	0.0	1.94
836.49	383	TDMA	26.7	Antenna Side	Flat	0.0	1.28
848.97	799	TDMA	25.4	Antenna Side	Flat	0.0	1.78
<b>Mixture Type: Muscle                      Dielectric Constant: 56.1                      Conductivity: 0.95</b>			<b>ANSI / IEEE C95.1 1992 - SAFETY LIMIT                      Spatial Peak Uncontrolled Exposure/General Population                      Hand SAR: 4.0 W/kg (averaged over 10 grams)</b>				

Notes:

1. All modes of operation were investigated and the worst-case SAR levels are reported.
2. The SAR values found were below the maximum limit of 4.0 w/kg.
3. The worst-case hand SAR value found was 2.30 w/kg.

**BODY SAR Measurement Results**

Freq. (MHz)	Chan.	Mode Tested	Max. Conducted Pwr. (dBm)	EUT Position	Phantom Section	Separation Distance (cm)	SAR (w/kg)
824.04	991	TDMA	26.5	Front side	Flat	1.0	1.43
836.49	383	TDMA	26.7	Front side	Flat	1.0	1.24
848.97	799	TDMA	25.4	Front side	Flat	1.0	1.22
<b>Mixture Type: Muscle                      Dielectric Constant: 56.1                      Conductivity: 0.95</b>			<b>ANSI / IEEE C95.1 1992 - SAFETY LIMIT                      Spatial Peak Uncontrolled Exposure/General Population                      Body SAR: 1.6 W/kg (averaged over 1 gram)</b>				

Notes:

1. All modes of operation were investigated and the worst-case SAR levels are reported.
2. The SAR values found were below the maximum limit of 1.6 w/kg.
3. The worst-case body SAR value found was 1.43 w/kg.

**5.0 SAR SAFETY LIMITS**

<b>EXPOSURE LIMITS</b> (General populations/Uncontrolled Exposure Environment)	<b>SAR</b> (W/Kg)
Spatial Average (averaged over the whole body)	0.08
Spatial Peak (averaged over any 1g of tissue)	1.60
Spatial Peak (hands/wrists/feet/ankles averaged over 10g)	4.00

- Notes: 1. The FCC SAR safety limits specified in the table above apply to devices operated in the General Population / Uncontrolled Exposure environment.  
 2. Uncontrolled environments are defined as locations where there is exposure of individuals who have no knowledge or control of their exposure.

## 6.0 DETAILS OF SAR EVALUATION

The NEXTCELL INC. POCKETSPIDER<sup>®</sup> CDPD Modem Module was found to be compliant for localized Specific Absorption Rate (SAR) based on the following test provisions and conditions:

- 1) The EUT was tested in a hand-held configuration with the front of the device placed parallel to and touching the outer surface of the planar phantom.
- 2) The EUT was tested in a hand-held configuration with the back of the device placed parallel to and touching the outer surface of the planar phantom.
- 3) The EUT was tested in a hand-held configuration with the antenna side of the device placed parallel to and touching the outer surface of the planar phantom.
- 4) To determine the test position and separation distance required to pass the 1gram average limit for body SAR, the 1gram average from the hand-SAR data was used. The highest 1gram average for 0cm separation distance occurred on the front side and on the low channel 991. The following table shows the 1gram average test data from the hand SAR.

Freq. (MHz)	Chan.	Mode Tested	Max. Conducted Pwr. (dBm)	EUT Position	Phantom Section	Separation Distance (cm)	SAR (w/kg) 1 gram average
824.04	991	TDMA	26.5	Front Side	Flat	0.0	3.89
824.04	991	TDMA	26.5	Antenna Side	Flat	0.0	3.50
824.04	991	TDMA	26.5	Back Side	Flat	0.0	1.89

- 5) The EUT was tested in a body-worn configuration with the front of the device placed parallel to the outer surface of the planar phantom with a 1.0cm separation distance.
- 6) SAR measurements were evaluated at maximum power and the unit was operated for an appropriate period prior to the evaluation in order to minimize drift.
- 7) The device was keyed to operate continuously in the transmit mode for the duration of the test.
- 8) The location of the maximum spatial SAR distribution (Hot Spot) was determined relative to the device and its antenna.
- 9) The EUT was tested with a fully charged battery.



Fig. 6. Hand SAR - Front Side (0cm Separation Distance)

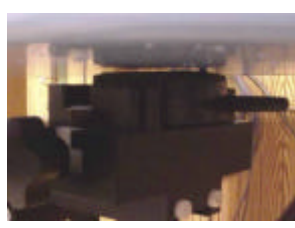

Fig. 7. Hand SAR - Back Side (0cm Separation Distance)

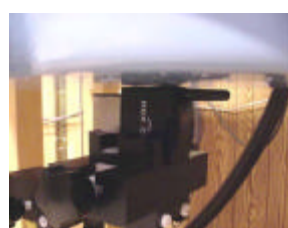

Fig. 8. Hand SAR - Antenna Side (0cm Separation Distance)



Fig. 9. Body SAR - Front Side (1cm Separation Distance)



## 7.0 EVALUATION PROCEDURES

The Specific Absorption Rate (SAR) evaluation was performed in the following manner:

- a. (i) The evaluation was performed in the appropriate area of the phantom depending on the type of device being tested. For devices worn about the ear during normal operation, both the left and right ear positions were evaluated at the center frequency of the band at maximum power. The ear position that produced the greatest SAR determined which side of the phantom would be used for the entire evaluation. The positioning of the head-worn device relative to the phantom was dictated by FCC OET bulletin 65 Supp., C.  
(ii) For face-held, hand-held, and body-worn devices, or devices which can be operated within 20cm of the body, the planar section of the phantom was used. The type of device being evaluated dictated the distance of the EUT to the outer surface of the planar phantom.
- b. The SAR was determined by a pre-defined procedure within the DASY3 software. Upon completion of a reference and optical surface check, the exposed region of the phantom was scanned near the inner surface with a grid spacing of 20mm x 20mm.
- c. A 5x5x7 matrix was performed around the greatest spatial SAR distribution found during the area scan of the applicable exposed region. SAR values were then calculated using a 3-D spline interpolation algorithm and averaged over spatial volumes of 1 and 10 grams.
- d. If the EUT had any appreciable drift over the course of the evaluation, then the EUT was re-evaluated. Any unusual anomalies over the course of the test also warranted a re-evaluation.

## 8.0 SYSTEM VALIDATION

Prior to the assessment, the system was verified in the planar region of the phantom. For devices operating below 1GHz, an 835MHz or 900MHz dipole was used, depending on the operating frequency of the EUT. For devices operating above 1GHz, an 1800MHz dipole was used. A forward power of 250mW was applied to the dipole and system was verified to a tolerance of  $\pm 5\%$ . Following the validation, the fluid remained or was changed depending on the particular part of the body being evaluated. The applicable verification(s) is/are as follows (see Appendix B for validation test plot):

Dipole Validation Kit	Target SAR 1g (w/kg)	Measured SAR 1g (w/kg)
D835V2	2.06	2.04



## 9.0 SIMULATED TISSUES

The brain and muscle mixtures consist of a viscous gel using hydroxethylcellulose (HEC) gelling agent and saline solution. Preservation with a bactericide is added and visual inspection is made to ensure air bubbles are not trapped during the mixing process. The mixture is calibrated to obtain proper dielectric constant (permittivity) and conductivity of the tissue.

INGREDIENT	MIXTURE - 835MHz	
	Muscle %	Brain % (Validation)
Water	52.4	40.1
Sugar	45.0	58.1
Salt	1.4	0.7
HEC	1.0	1.0
Bactericide	0.2	0.1

## 10.0 TISSUE PARAMETERS

The dielectric parameters of the fluids were verified prior to the SAR evaluation using an 85070C Dielectric Probe Kit and an 8753E Network Analyzer. The dielectric parameters of the fluid are as follows:

Simulated Tissue (835MHz)	Dielectric Constant $\epsilon_r$	Conductivity $S$ (mho/m)	$\rho$ (Kg/m <sup>3</sup> )
Muscle	56.1 $\pm$ 5%	0.95 $\pm$ 5%	1000
Brain (Validation)	44.2 $\pm$ 5%	0.80 $\pm$ 5%	1000

## ***11.0 ROBOT SYSTEM SPECIFICATIONS***

### **Specifications**

**POSITIONER:** Staubli Unimation Corp. Robot Model: RX60L  
**Repeatability:** 0.02 mm  
**No. of axis:** 6

### **Data Acquisition Electronic (DAE) System**

#### **Cell Controller**

**Processor:** Pentium III  
**Clock Speed:** 450 MHz  
**Operating System:** Windows NT  
**Data Card:** DASY3 PC-Board

#### **Data Converter**

**Features:** Signal Amplifier, multiplexer, A/D converter, and control logic  
**Software:** DASY3 software  
**Connecting Lines:** Optical downlink for data and status info.  
Optical uplink for commands and clock

### **PC Interface Card**

**Function:** 24 bit (64 MHz) DSP for real time processing  
Link to DAE3  
16 bit A/D converter for surface detection system  
serial link to robot  
direct emergency stop output for robot

### **E-Field Probe**

**Model:** ET3DV6  
**Serial No.:** 1387  
**Construction:** Triangular core fiber optic detection system  
**Frequency:** 10 MHz to 6 GHz  
**Linearity:**  $\pm 0.2$  dB (30 MHz to 3 GHz)

### **Phantom**

**Phantom:** Generic Twin  
**Shell Material:** Fiberglass  
**Thickness:**  $2.0 \pm 0.1$  mm

**12.0 TEST EQUIPMENT LIST**

<b>SAR MEASUREMENT SYSTEM</b>		
<b><u>EQUIPMENT</u></b>	<b><u>S/N #</u></b>	<b><u>CALIB. DATE</u></b>
<b>DASY3 System</b> -Robot -ET3DV6 E-Field Probe -DAE -835MHz Validation Dipole -900MHz Validation Dipole -1800MHz Validation Dipole -Generic Twin Phantom V3.0	599396-01 1387 383 411 054 247 N/A	N/A Sept 1999 Sept 1999 Aug 1999 Aug 1999 Aug 1999 N/A
<b>85070C Dielectric Probe Kit</b>	N/A	N/A
<b>Gigatronics 8652A Power Meter</b> -Power Sensor 80701A -Power Sensor 80701A	1835272 1833535 1833542	Oct 1999 Oct 1999 Oct 1999
<b>E4408B Spectrum Analyzer</b>	US39240170	Nov 1999
<b>8594E Spectrum Analyzer</b>	3543A02721	Mar 2000
<b>8753E Network Analyzer</b>	US38433013	Nov 1999
<b>8648D Signal Generator</b>	3847A00611	N/A
<b>5S1G4 Amplifier Research Power Amplifier</b>	26235	N/A

### 13.0 MEASUREMENT UNCERTAINTIES

Uncertainty Description	Error	Distribution	Weight	Standard Deviation	Offset
<b>Probe Uncertainty</b>					
Axial isotropy	±0.2 dB	U-Shaped	0.5	±2.4 %	
Spherical isotropy	±0.4 dB	U-Shaped	0.5	±4.8 %	
Isotropy from gradient	±0.5 dB	U-Shaped	0	±	
Spatial resolution	±0.5 %	Normal	1	±0.5 %	
Linearity error	±0.2 dB	Rectangle	1	±2.7 %	
Calibration error	±3.3 %	Normal	1	±3.3 %	
<b>SAR Evaluation Uncertainty</b>					
Data acquisition error	±1 %	Rectangle	1	±0.6 %	
ELF and RF disturbances	±0.25 %	Normal	1	±0.25 %	
Conductivity assessment	±5 %	Rectangle	1	±5.8 %	
<b>Spatial Peak SAR Evaluation Uncertainty</b>					
Extrapolated boundary effect	±3 %	Normal	1	±3 %	±5 %
Probe positioning error	±0.1 mm	Normal	1	±1 %	
Integrated and cube orientation	±3 %	Normal	1	±3 %	
Cube Shape inaccuracies	±2 %	Rectangle	1	±1.2 %	
Device positioning	±6 %	Normal	1	±6 %	
<b>Combined Uncertainties</b>				±11.7 %	±5 %

Measurement uncertainties in SAR measurements are difficult to quantify due to several variables including biological, physiological, and environmental. However, the estimated measurement uncertainties in SAR are less than 15-25 %.

According to ANSI/IEEE C95.3, the overall uncertainties are difficult to assess and will vary with the type of meter and usage situation. However, accuracy's of ± 1 to 3 dB can be expected in practice, with greater uncertainties in near-field situations and at higher frequencies (shorter wavelengths), or areas where large reflecting objects are present. Under optimum measurement conditions, SAR measurement uncertainties of at least ± 2dB can be expected.

According to CENELEC, typical worst-case uncertainty of field measurements is ± 5 dB. For well-defined modulation characteristics the uncertainty can be reduced to ± 3 dB.

## **14.0 REFERENCES**

- (1) ANSI, *ANSI/IEEE C95.1: IEEE Standard for Safety Levels with Respect to Human Exposure to Radio Frequency Electromagnetic Fields, 3kHz to 300 Ghz*, The Institute of Electrical and Electronics Engineers, Inc., New York, NY 10017, 1992;
- (2) Federal Communications Commission, “Evaluating Compliance with FCC Guidelines for Human Exposure to Radio frequency Electromagnetic Fields”, OET Bulletin 65, FCC, Washington, D.C. 20554, 1997;
- (3) Thomas Schmid, Oliver Egger, and Neils Kuster, “Automated E-field scanning system for dosimetric assessments”, *IEEE Transaction on Microwave Theory and Techniques*, Vol. 44, pp. 105 – 113, January, 1996.
- (4) Niels Kuster, Ralph Kastle, and Thomas Schmid, “Dosimetric evaluation of mobile communications equipment with know precision”, *IEICE Transactions of Communications*, vol. E80-B, no. 5, pp. 645 – 652, May 1997.

***APPENDIX A - SAR MEASUREMENT DATA***

# NEXTCELL FCC ID: MIVCDP06PS

Generic Twin Phantom; Flat Section; Position: (90°,90°)  
Probe: ET3DV6 - SN1387; ConvF(6.43,6.43,6.43); Crest factor: 3.0  
Muscle 835 MHz:  $\sigma = 0.95$  mho/m  $\epsilon_r = 56.1$   $\rho = 1.00$  g/cm<sup>3</sup>  
Coarse: Dx = 20.0, Dy = 20.0, Dz = 10.0  
Cube 5x5x7  
SAR (1g): 1.43 mW/g, SAR (10g): 0.904 mW/g

Body SAR Separation Distance 1.0cm (front side of unit)  
Model: PocketSpider CDPD Modem  
TDMA Mode  
Low Channel 991[824.04MHz]  
Conducted Power 26.5dBm  
Date Tested: Dec 14, 2000

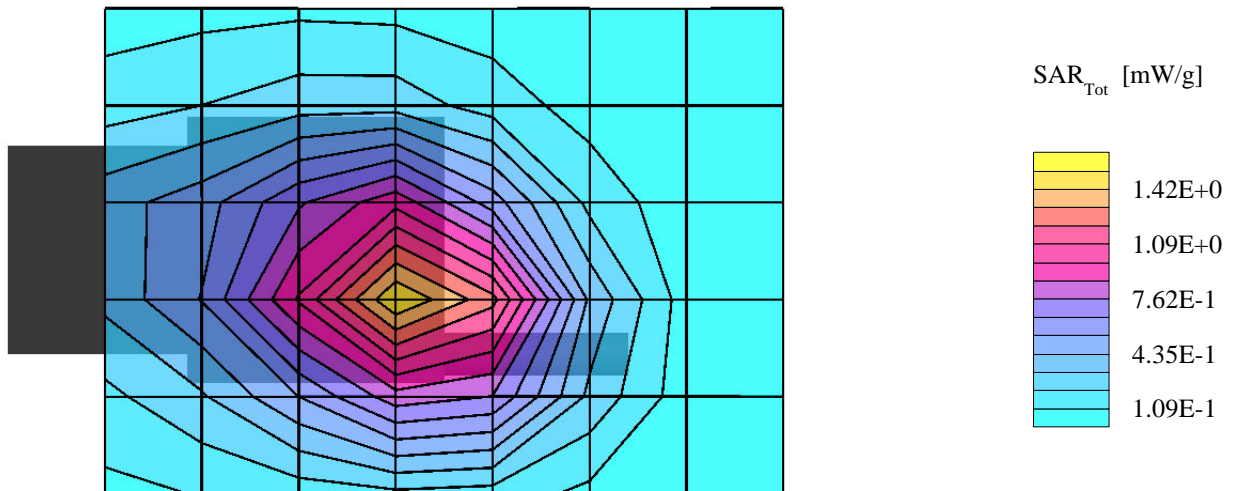



### NEXTCELL FCC ID: MIVCDP06PS

Generic Twin Phantom; Flat Section; Position: (90°,90°)  
Probe: ET3DV6 - SN1387; ConvF(6.43,6.43,6.43); Crest factor: 3.0  
Muscle 835 MHz:  $\sigma = 0.95$  mho/m  $\epsilon_r = 56.1$   $\rho = 1.00$  g/cm<sup>3</sup>  
Coarse: Dx = 20.0, Dy = 20.0, Dz = 10.0  
Cube 5x5x7  
SAR (1g): 1.24 mW/g, SAR (10g): 0.788 mW/g

Body SAR Separation Distance 1.0cm (front side of unit)  
Model: PocketSpider CDPD Modem  
TDMA Mode  
Mid Channel 383 (836.49MHz)  
Conducted Power 26.7dBm  
Date Tested: Dec 14, 2000

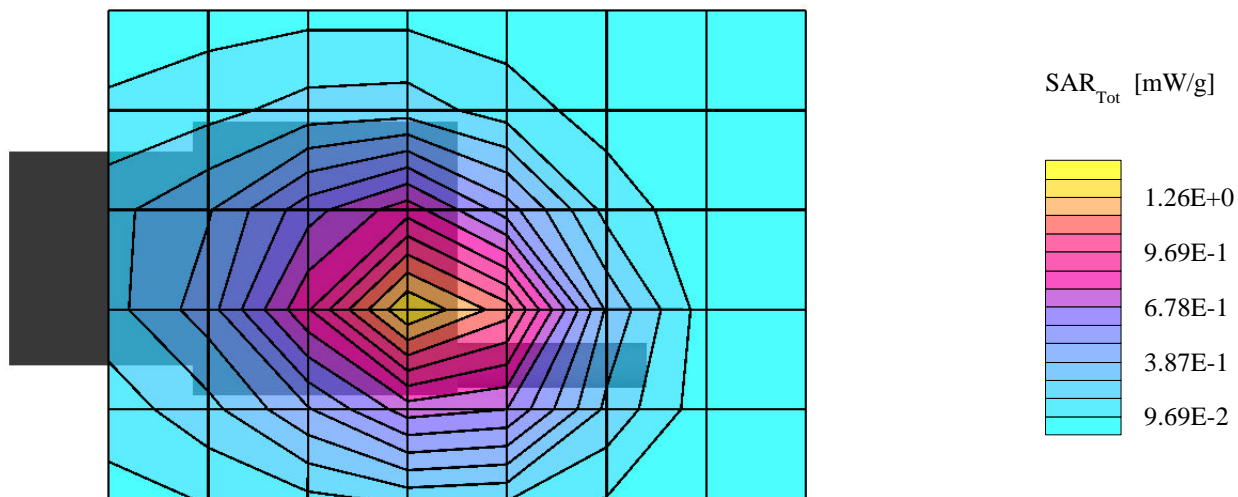

## NEXTCELL FCC ID: MIVCDP06PS

Generic Twin Phantom; Flat Section; Position: (90°,90°)  
Probe: ET3DV6 - SN1387; ConvF(6.43,6.43,6.43); Crest factor: 3.0  
Muscle 835 MHz:  $\sigma = 0.95$  mho/m  $\epsilon_r = 56.1$   $\rho = 1.00$  g/cm<sup>3</sup>  
Coarse: Dx = 20.0, Dy = 20.0, Dz = 10.0  
Cube 5x5x7  
SAR (1g): 1.22 mW/g, SAR (10g): 0.778 mW/g

Body SAR Separation Distance 1.0cm (front side of unit)  
Model: PocketSpider CDPD Modem  
TDMA Mode  
High Channel 799 [848.97MHz]  
Conducted Power 25.4dBm  
Date Tested: Dec 14, 2000

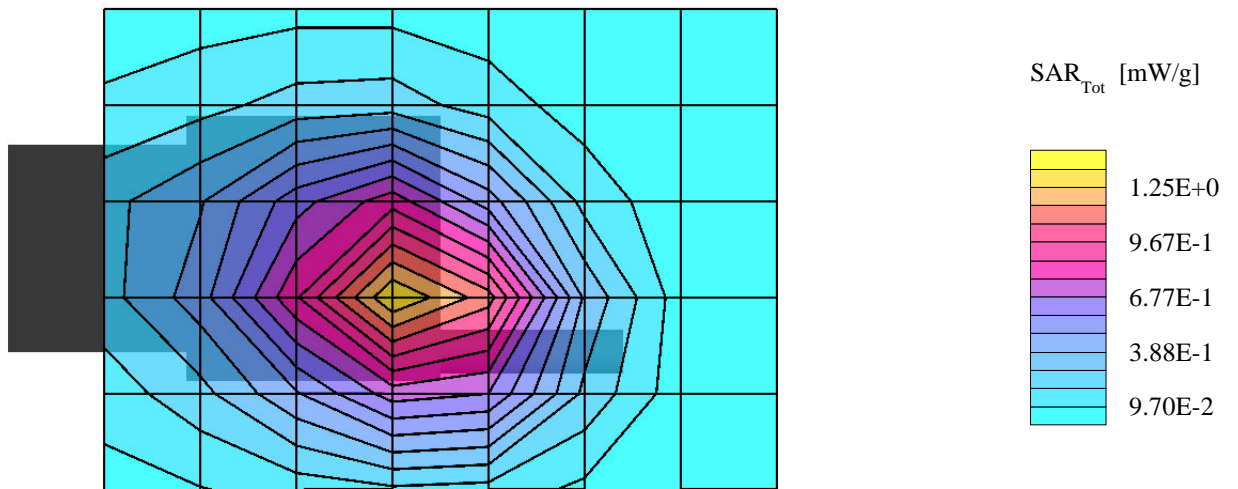

### NEXTCELL FCC ID: MIVCDP06PS

Generic Twin Phantom; Flat Section; Position: (270°,270°)  
Probe: ET3DV6 - SN1387; ConvF(6.43,6.43,6.43); Crest factor: 3.0  
Muscle 835 MHz:  $\sigma = 0.95$  mho/m  $\epsilon_r = 56.1$   $\rho = 1.00$  g/cm<sup>3</sup>  
Coarse: Dx = 20.0, Dy = 20.0, Dz = 10.0  
Cube 5x5x7  
SAR (1g): 3.89 mW/g, SAR (10g): 2.30 mW/g

Hand SAR 0.0cm Separation Distance (front side of unit)  
Model: PocketSpider CDPD Modem  
TDMA Mode  
Low Channel 991 [824.04MHz]  
Conducted Power 26.5dBm  
Date Tested: Dec 14, 2000

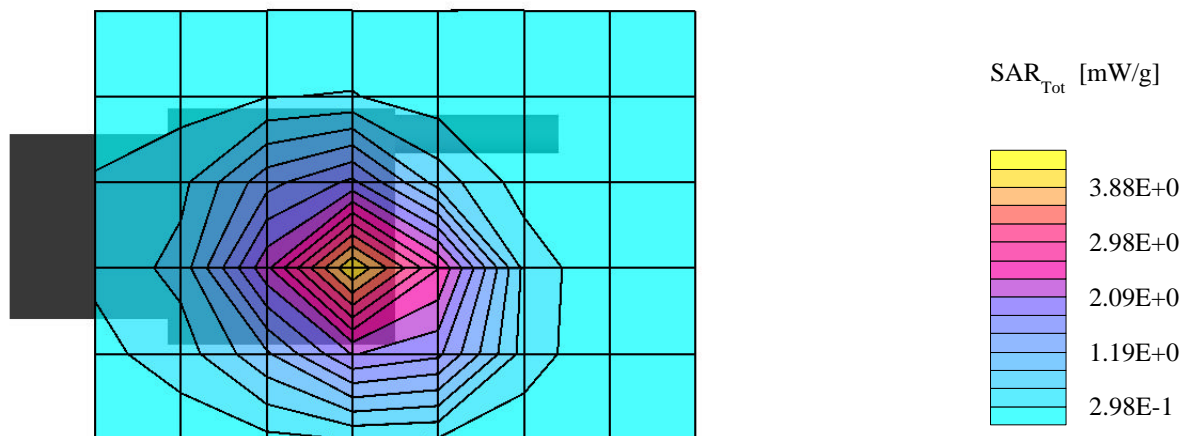

### NEXTCELL FCC ID: MIVCDP06PS

Generic Twin Phantom; Flat Section; Position: (90°,90°)  
Probe: ET3DV6 - SN1387; ConvF(6.43,6.43,6.43); Crest factor: 3.0  
Muscle 835 MHz:  $\sigma = 0.95$  mho/m  $\epsilon_r = 56.1$   $\rho = 1.00$  g/cm<sup>3</sup>  
Coarse: Dx = 20.0, Dy = 20.0, Dz = 10.0  
Cube 5x5x7  
SAR (1g): 2.39 mW/g, SAR (10g): 1.41 mW/g

Hand SAR 0.0cm Separation Distance (front side of unit)  
Model: PocketSpider CDPD Modem  
TDMA Mode  
Mid Channel 383 [836.49MHz]  
Conducted Power 26.7dBm  
Date Tested: Dec 14, 2000

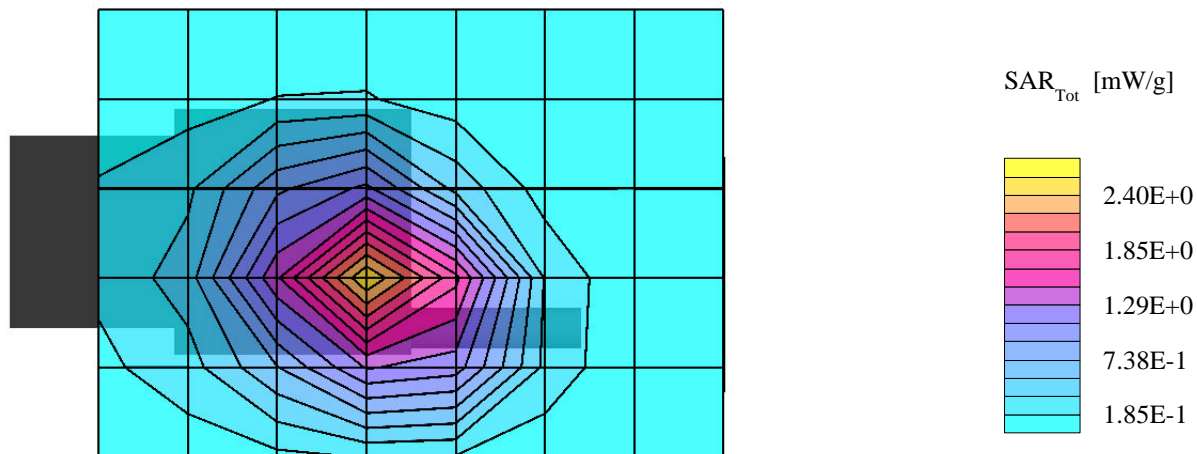

### NEXTCELL FCC ID: MIVCDP06PS

Generic Twin Phantom; Flat Section; Position: (270°,270°)  
Probe: ET3DV6 - SN1387; ConvF(6.43,6.43,6.43); Crest factor: 3.0  
Muscle 835 MHz:  $\sigma = 0.95$  mho/m  $\epsilon_r = 56.1$   $\rho = 1.00$  g/cm<sup>3</sup>  
Coarse: Dx = 20.0, Dy = 20.0, Dz = 10.0  
Cube 5x5x7  
SAR (1g): 3.11 mW/g, SAR (10g): 1.84 mW/g

Hand SAR 0.0cm Separation Distance (front side of unit)  
Model: PocketSpider CDPD Modem  
TDMA Mode  
High Channel 799 [848.97MHz]  
Conducted Power 25.4dBm  
Date Tested: Dec 14, 2000

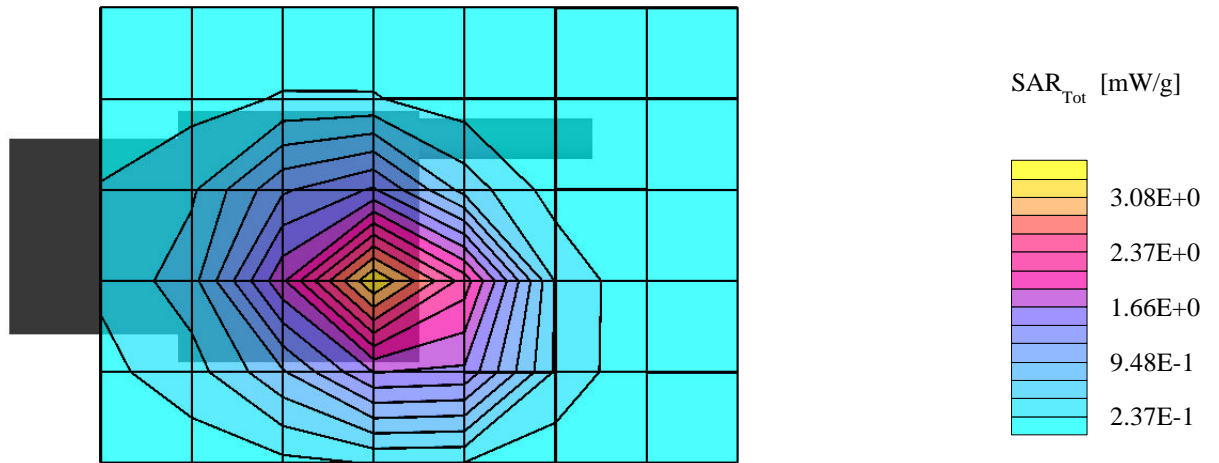

### NEXTCELL FCC ID: MIVCDP06PS

Generic Twin Phantom; Flat Section; Position: (270°,270°)  
Probe: ET3DV6 - SN1387; ConvF(6.43,6.43,6.43); Crest factor: 3.0  
Muscle 835 MHz:  $\sigma = 0.95$  mho/m  $\epsilon_r = 56.1$   $\rho = 1.00$  g/cm<sup>3</sup>  
Coarse: Dx = 20.0, Dy = 20.0, Dz = 10.0  
Cube 5x5x7  
SAR (10g): 1.17 mW/g

Hand SAR Back Side of Unit 0.0cm Separation Distance  
Model: PocketSpider CDPD Modem  
TDMA Mode  
Low Channel 991 [824.04MHz]  
Conducted Power 26.5dBm  
Date Tested: Dec 14, 2000

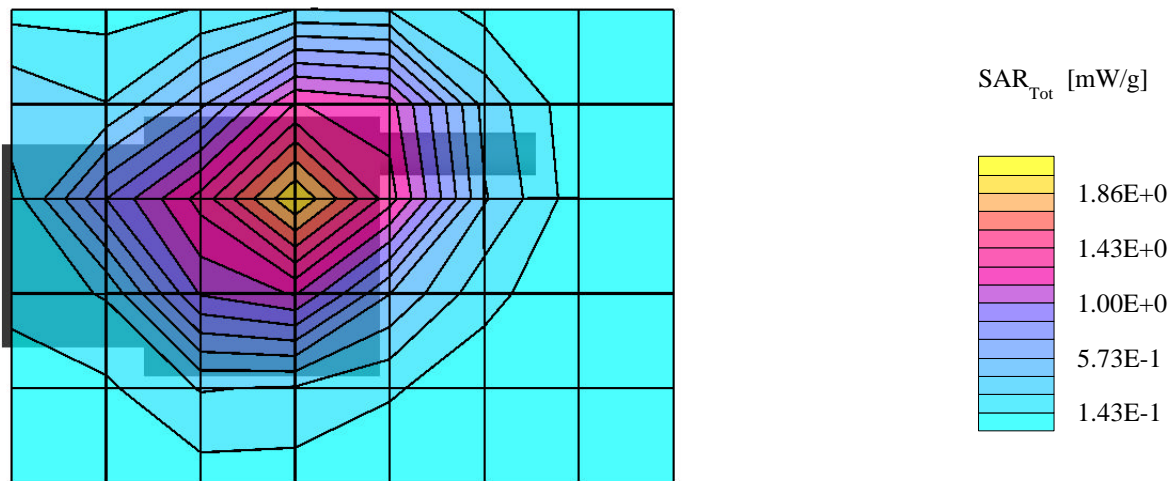

### NEXTCELL FCC ID: MIVCDP06PS

Generic Twin Phantom; Flat Section; Position: (270°,270°)  
Probe: ET3DV6 - SN1387; ConvF(6.43,6.43,6.43); Crest factor: 3.0  
Muscle 835 MHz:  $\sigma = 0.95$  mho/m  $\epsilon_r = 56.1$   $\rho = 1.00$  g/cm<sup>3</sup>  
Coarse: Dx = 20.0, Dy = 20.0, Dz = 10.0  
Cube 5x5x7  
SAR (10g): 0.830 mW/g

Hand SAR Back Side of Unit 0.0cm Separation Distance  
Model: PocketSpider CDPD Modem  
TDMA Mode  
Mid Channel 383 [836.49MHz]  
Conducted Power 26.7dBm  
Date Tested: Dec 14, 2000

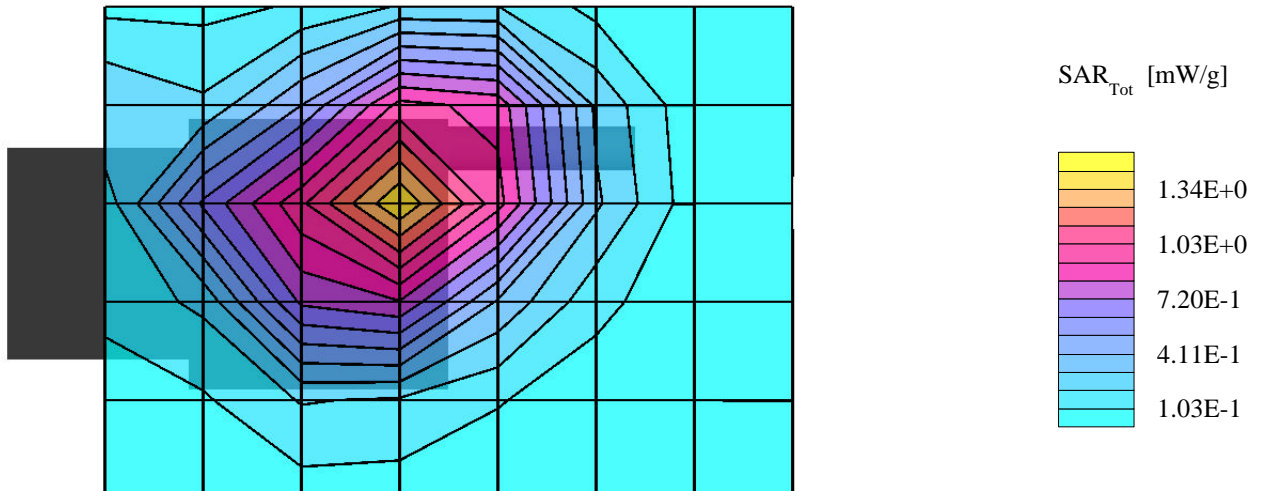



## NEXTCELL FCC ID: MIVCDP06PS

Generic Twin Phantom; Flat Section; Position: (270°,270°)  
Probe: ET3DV6 - SN1387; ConvF(6.43,6.43,6.43); Crest factor: 3.0  
Muscle 835 MHz:  $\sigma = 0.95$  mho/m  $\epsilon_r = 56.1$   $\rho = 1.00$  g/cm<sup>3</sup>  
Coarse: Dx = 20.0, Dy = 20.0, Dz = 10.0  
Cube 5x5x7  
SAR (10g): 0.968 mW/g

Hand SAR Back Side of Unit 0.0cm Separation Distance  
Model: PocketSpider CDPD Modem  
TDMA Mode  
High Channel 799 [848.97MHz]  
Conducted Power 25.4dBm  
Date Tested: Dec 14, 2000

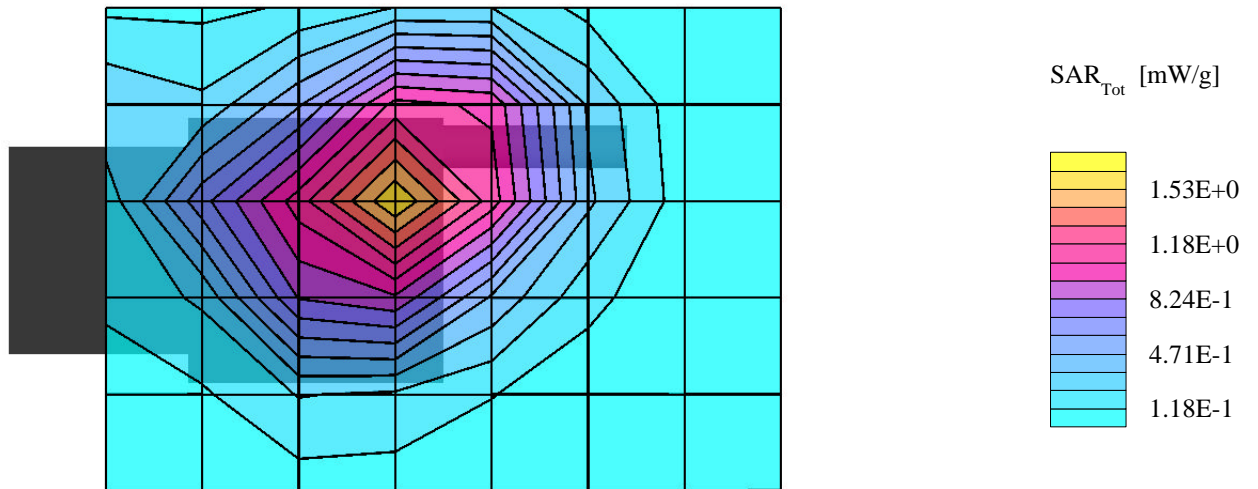

## NEXTCELL FCC ID: MIVCDP06PS

Generic Twin Phantom; Flat Section; Position: (90°,90°)  
Probe: ET3DV6 - SN1387; ConvF(6.43,6.43,6.43); Crest factor: 3.0  
Muscle 835 MHz:  $\sigma = 0.95$  mho/m  $\epsilon_r = 56.1$   $\rho = 1.00$  g/cm<sup>3</sup>  
Coarse: Dx = 20.0, Dy = 20.0, Dz = 10.0  
Cube 5x5x7  
SAR (10g): 1.94 mW/g

Hand SAR Antenna Side 0.0cm Separation Distance  
Model: PocketSpider CDPD Modem  
TDMA Mode  
Low Channel 991 [824.04MHz]  
Conducted Power 26.5dBm  
Date Tested: Dec 14, 2000

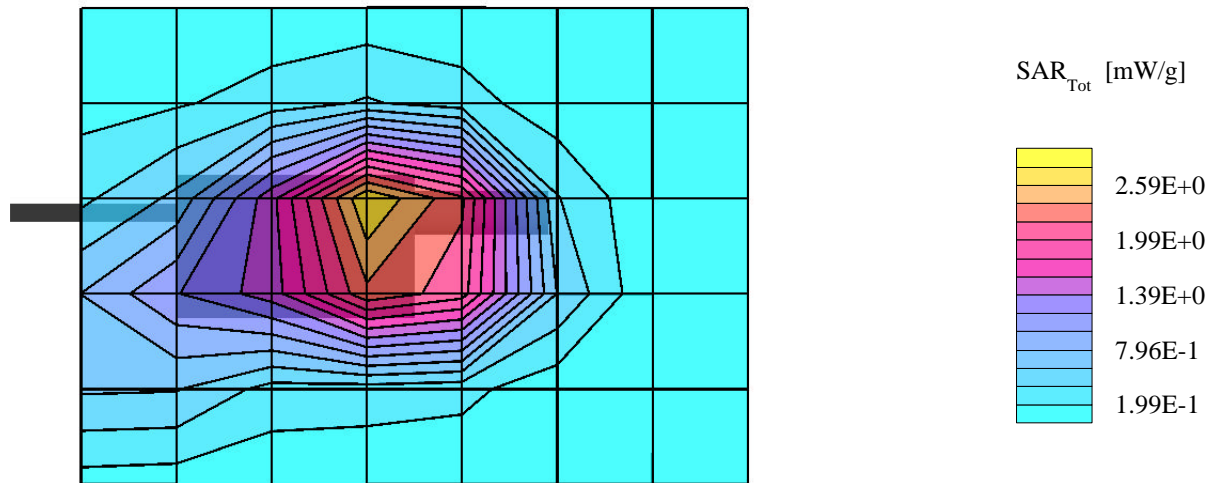

## NEXTCELL FCC ID: MIVCDP06PS

Generic Twin Phantom; Flat Section; Position: (90°,90°)  
Probe: ET3DV6 - SN1387; ConvF(6.43,6.43,6.43); Crest factor: 3.0  
Muscle 835 MHz:  $\sigma = 0.95$  mho/m  $\epsilon_r = 56.1$   $\rho = 1.00$  g/cm<sup>3</sup>  
Coarse: Dx = 20.0, Dy = 20.0, Dz = 10.0  
Cube 5x5x7  
SAR (10g): 1.28 mW/g

Hand SAR Antenna Side 0.0cm Separation Distance  
Model: PocketSpider CDPD Modem  
TDMA Mode  
Mid Channel 383 [836.49MHz]  
Conducted Power 26.7dBm  
Date Tested: Dec 14, 2000

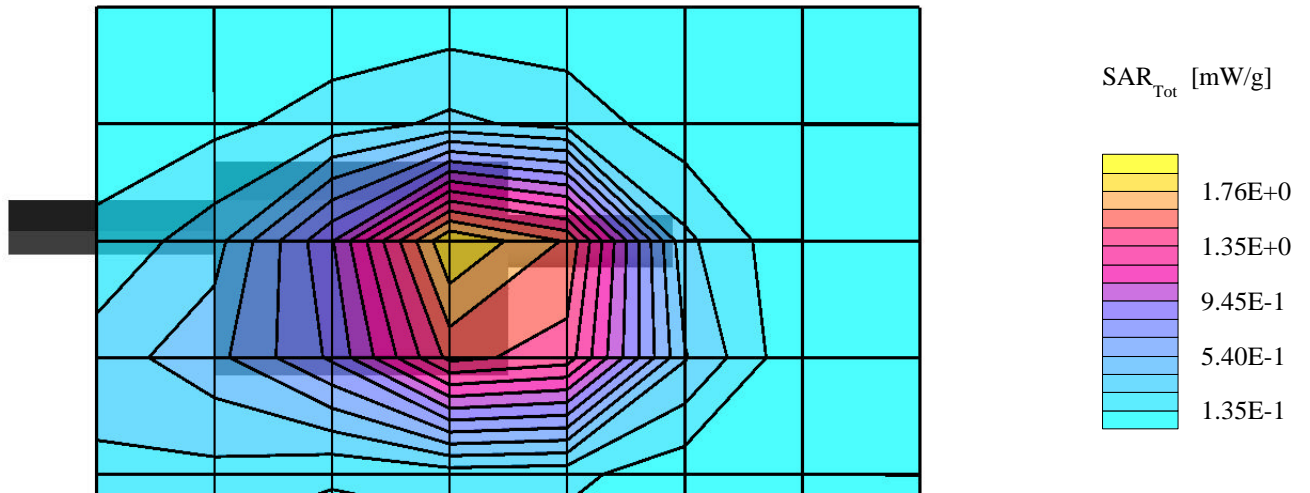

## NEXTCELL FCC ID: MIVCDP06PS

Generic Twin Phantom; Flat Section; Position: (90°,90°)  
Probe: ET3DV6 - SN1387; ConvF(6.43,6.43,6.43); Crest factor: 3.0  
Muscle 835 MHz:  $\sigma = 0.95$  mho/m  $\epsilon_r = 56.1$   $\rho = 1.00$  g/cm<sup>3</sup>  
Coarse: Dx = 20.0, Dy = 20.0, Dz = 10.0  
Cube 5x5x7  
SAR (10g): 1.78 mW/g

Hand SAR Antenna Side 0.0cm Separation Distance  
Model: PocketSpider CDPD Modem  
TDMA Mode  
High Channel 799 [848.97MHz]  
Conducted Power 25.4dBm  
Date Tested: Dec 14, 2000

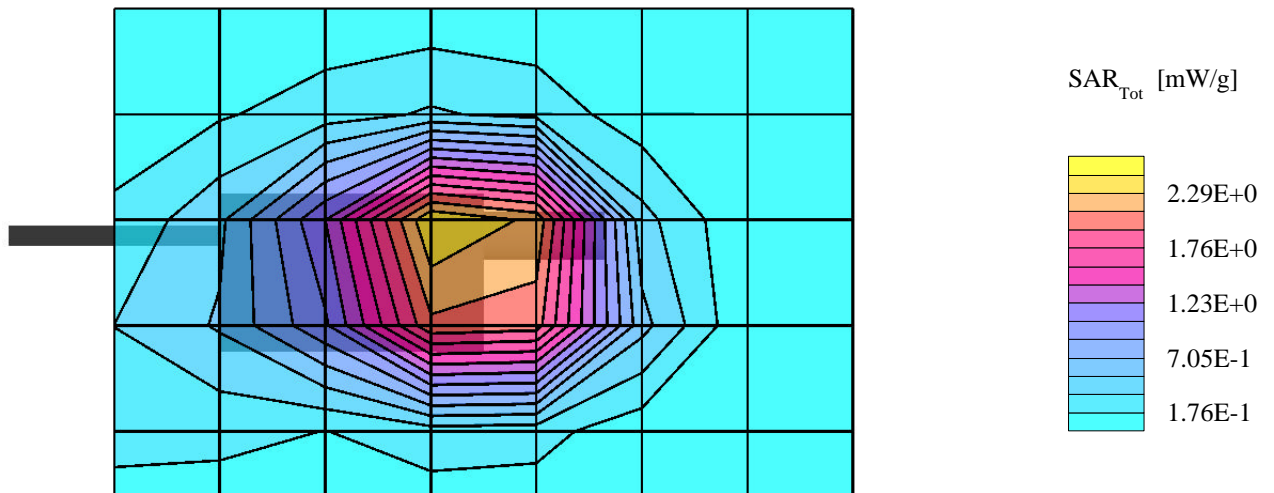

***APPENDIX B - DIPOLE VALIDATION***

## Dipole 835 MHz

Generic Twin Phantom; Flat Section; Position: (90°,90°);  
Probe: ET3DV6 - SN1387; ConvF(6.43,6.43,6.43); Crest factor: 1.0;  
Brain 835 MHz:  $\sigma = 0.80$  mho/m  $\epsilon_r = 44.2$   $\rho = 1.00$  g/cm<sup>3</sup>  
Coarse: Dx = 20.0, Dy = 20.0, Dz = 10.0  
Cube 5x5x7  
SAR (1g): 2.04 mW/g, SAR (10g): 1.34 mW/g

Validation Date: Dec. 14, 2000

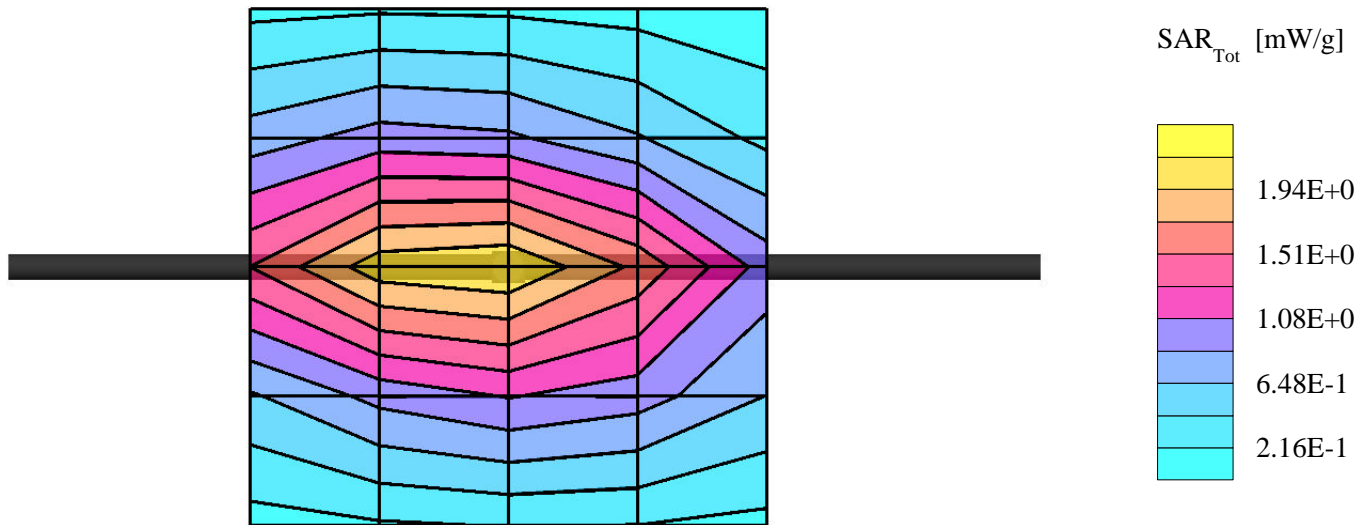

## Validation Dipole D835V2 SN:411, d = 15mm

Frequency: 835 MHz; Antenna Input Power: 250 [mW]

Generic Twin Phantom; Flat Section; Grid Spacing: Dx = 20.0, Dy = 20.0, Dz = 10.0

Probe: ET3DV5 - SN1342/DAE3; ConvF(5.75,5.75,5.75); Brain 835 MHz:  $\sigma = 0.80$  mho/m  $\epsilon_r = 44.2$   $\rho = 1.00$  g/cm<sup>3</sup>

Cubes (2): Peak: 3.07 mW/g  $\pm 0.05$  dB, SAR (1g): 2.06 mW/g  $\pm 0.05$  dB, SAR (10g): 1.38 mW/g  $\pm 0.05$  dB, (Worst-case extrapolation)

Penetration depth: 13.6 (12.7, 14.8) [mm]

Powerdrift: -0.00 dB

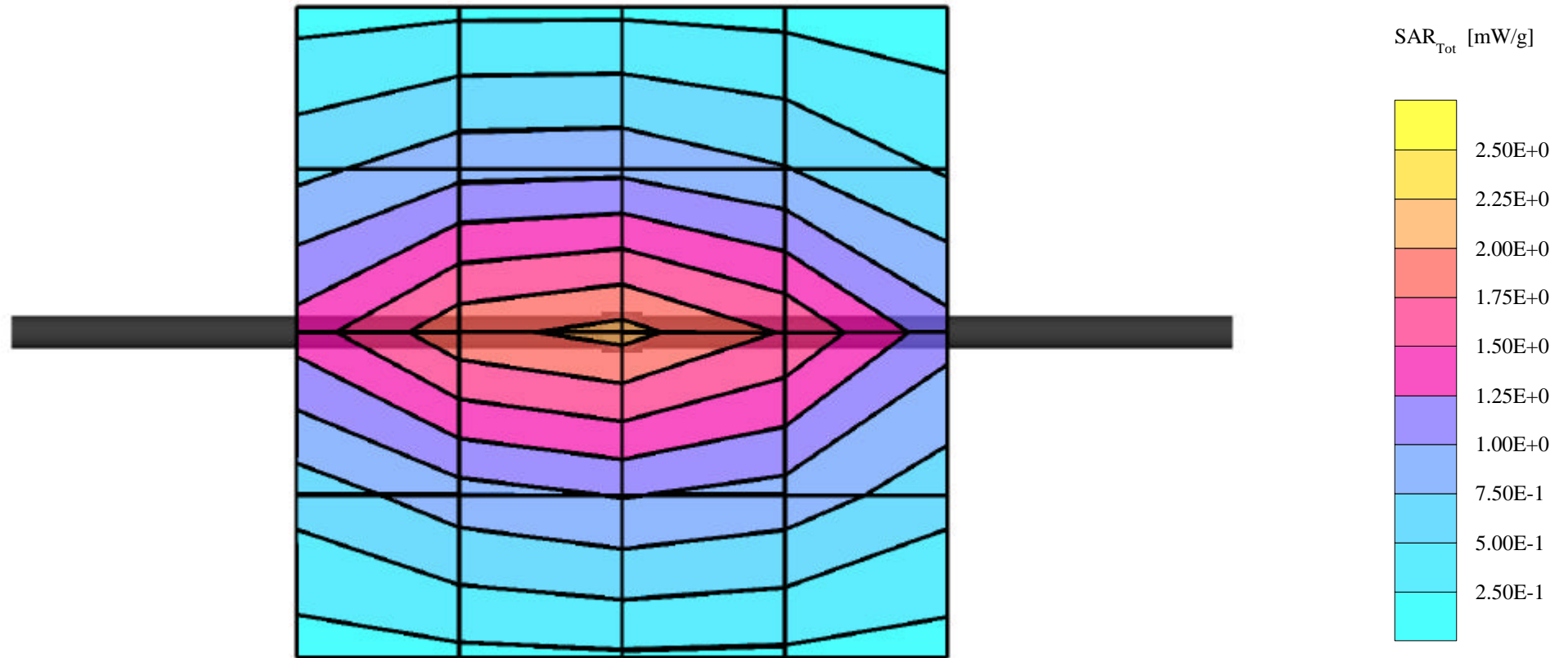



***APPENDIX C - PROBE CALIBRATION***

# Probe ET3DV6

**SN:1387**

Manufactured:	September 21, 1999
Last calibration:	September 22, 1999

Calibrated for System DASY3

## DASY3 - Parameters of Probe: ET3DV6 SN:1387

### Sensitivity in Free Space

NormX	<b>1.55</b> $\mu\text{V}/(\text{V}/\text{m})^2$
NormY	<b>1.65</b> $\mu\text{V}/(\text{V}/\text{m})^2$
NormZ	<b>1.64</b> $\mu\text{V}/(\text{V}/\text{m})^2$

### Diode Compression

DCP X	<b>98</b> mV
DCP Y	<b>98</b> mV
DCP Z	<b>98</b> mV

### Sensitivity in Tissue Simulating Liquid

**Brain**                      **450 MHz**                       $\epsilon_r = 48 \pm 5\%$                        $S = 0.50 \pm 10\%$  mho/m

ConvF X	<b>6.76</b> extrapolated	Boundary effect:
ConvF Y	<b>6.76</b> extrapolated	Alpha <b>0.30</b>
ConvF Z	<b>6.76</b> extrapolated	Depth <b>2.52</b>

**Brain**                      **900 MHz**                       $\epsilon_r = 42.5 \pm 5\%$                        $S = 0.86 \pm 10\%$  mho/m

ConvF X	<b>6.34</b> $\pm 7\%$ (k=2)	Boundary effect:
ConvF Y	<b>6.34</b> $\pm 7\%$ (k=2)	Alpha <b>0.47</b>
ConvF Z	<b>6.34</b> $\pm 7\%$ (k=2)	Depth <b>2.25</b>

**Brain**                      **1500 MHz**                       $\epsilon_r = 41 \pm 5\%$                        $S = 1.32 \pm 10\%$  mho/m

ConvF X	<b>5.78</b> interpolated	Boundary effect:
ConvF Y	<b>5.78</b> interpolated	Alpha <b>0.69</b>
ConvF Z	<b>5.78</b> interpolated	Depth <b>1.88</b>

**Brain**                      **1800 MHz**                       $\epsilon_r = 41 \pm 5\%$                        $S = 1.69 \pm 10\%$  mho/m

ConvF X	<b>5.50</b> $\pm 7\%$ (k=2)	Boundary effect:
ConvF Y	<b>5.50</b> $\pm 7\%$ (k=2)	Alpha <b>0.81</b>
ConvF Z	<b>5.50</b> $\pm 7\%$ (k=2)	Depth <b>1.70</b>

### Sensor Offset

Probe Tip to Sensor Center	<b>2.7</b>	mm
Optical Surface Detection	<b>1.6 <math>\pm</math> 0.2</b>	mm

# Receiving Pattern ( $f$ ), $q = 0^\circ$

**f = 30 MHz, TEM cell ifi110**

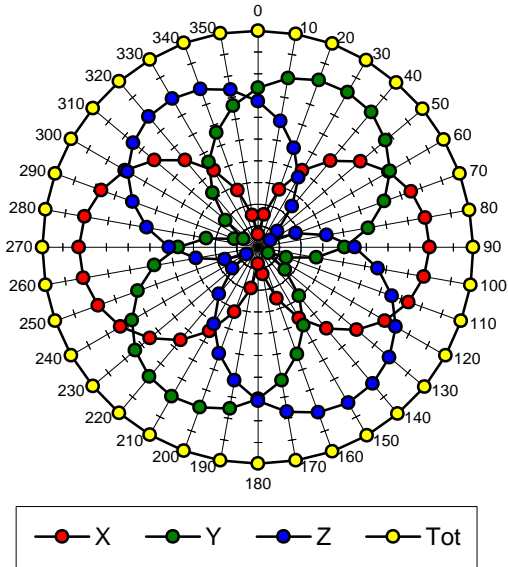

**f = 100 MHz, TEM cell ifi110**

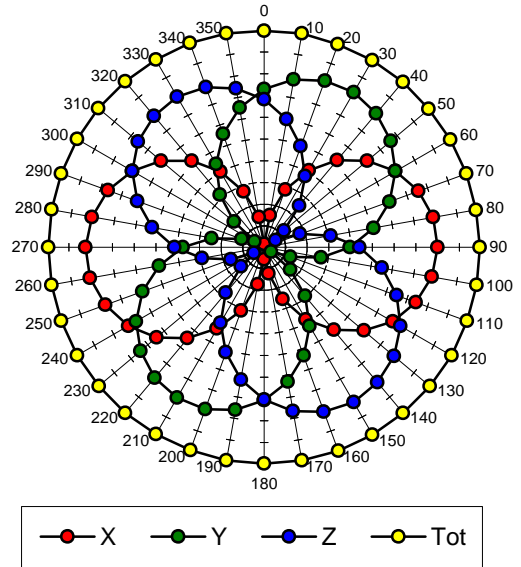

**f = 300 MHz, TEM cell ifi110**

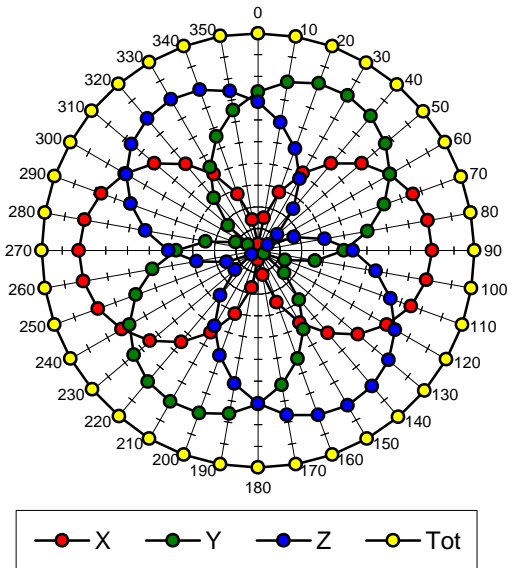

**f = 900 MHz, TEM cell ifi110**

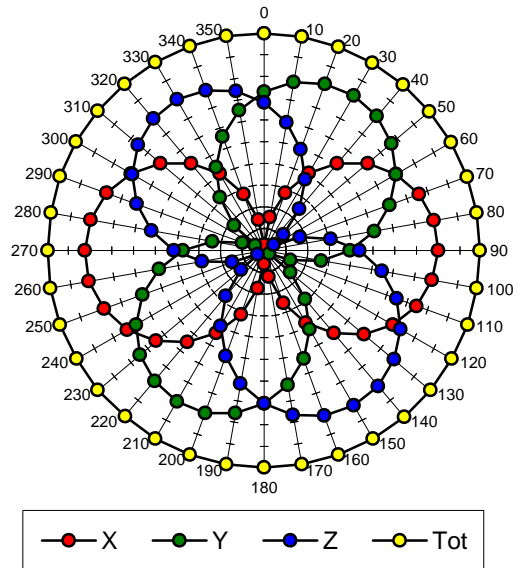

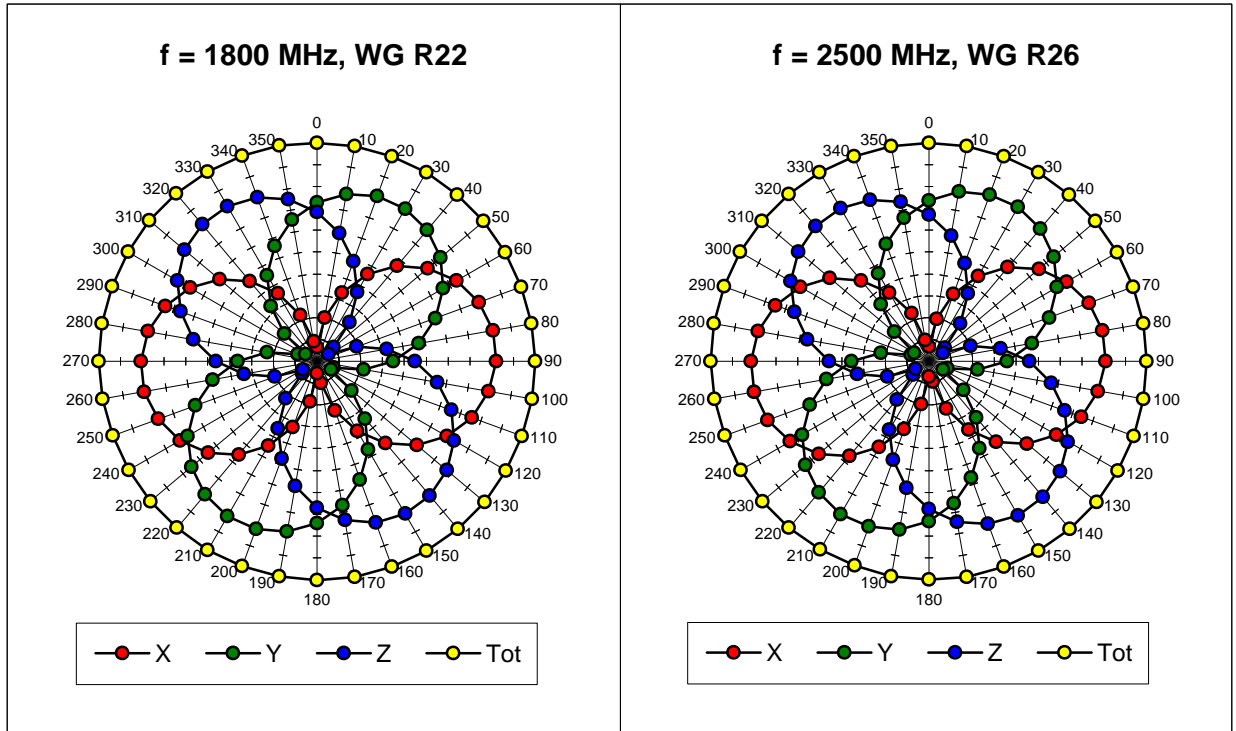

### Isotropy Error (f), q = 0°

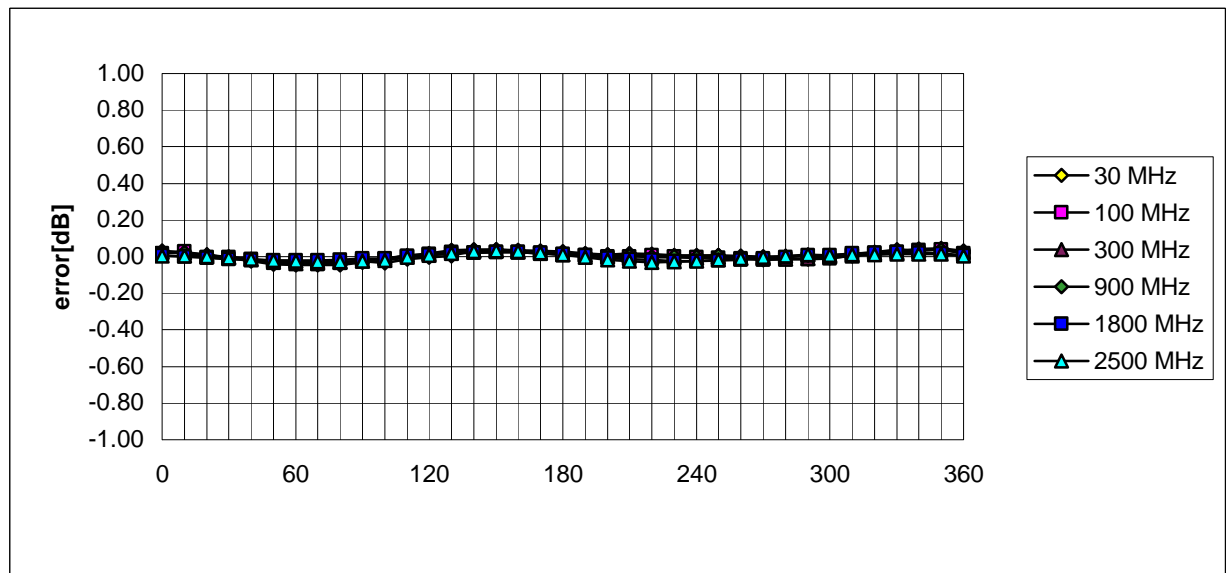

# Frequency Response of E-Field

( TEM-Cell:ifi110, Waveguide R22, R26 )

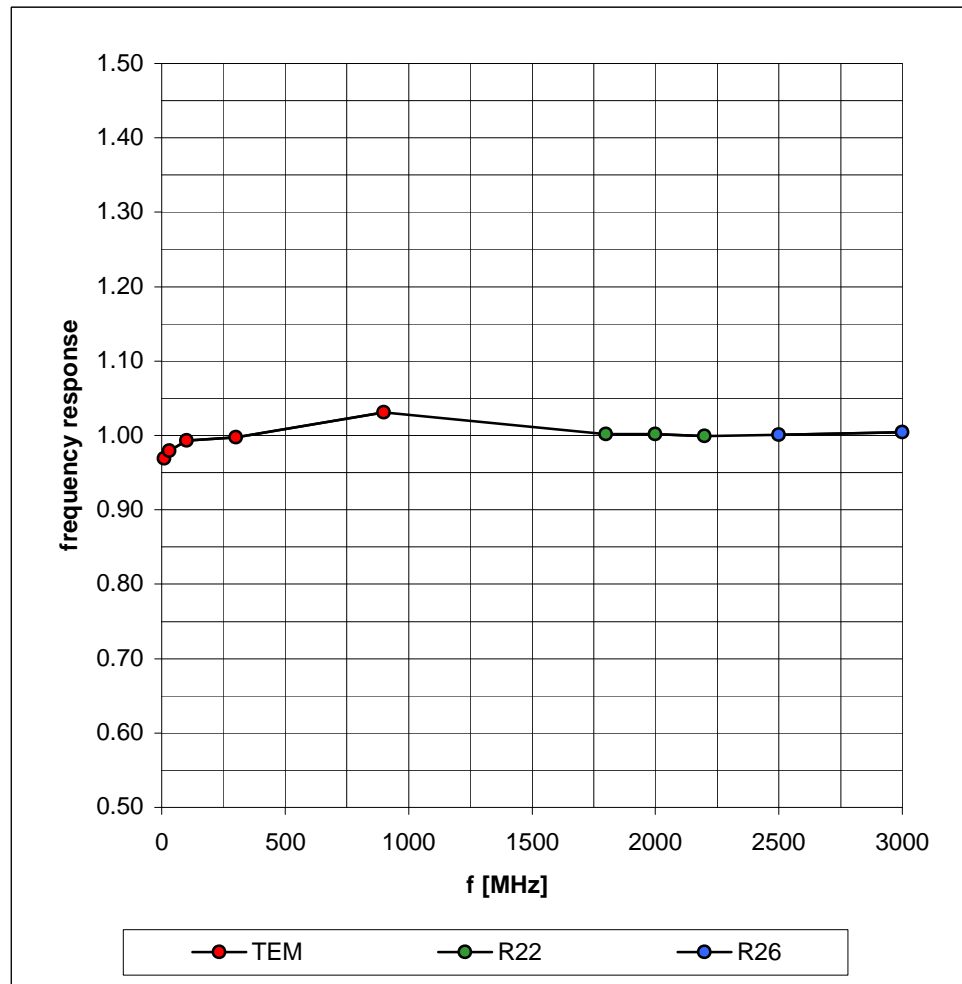

## Dynamic Range f(SAR<sub>brain</sub>) ( TEM-Cell:ifi110 )

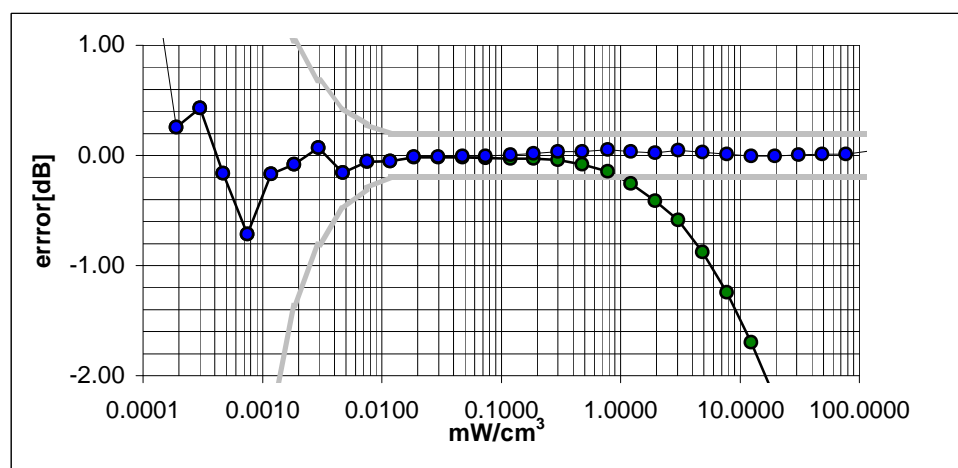
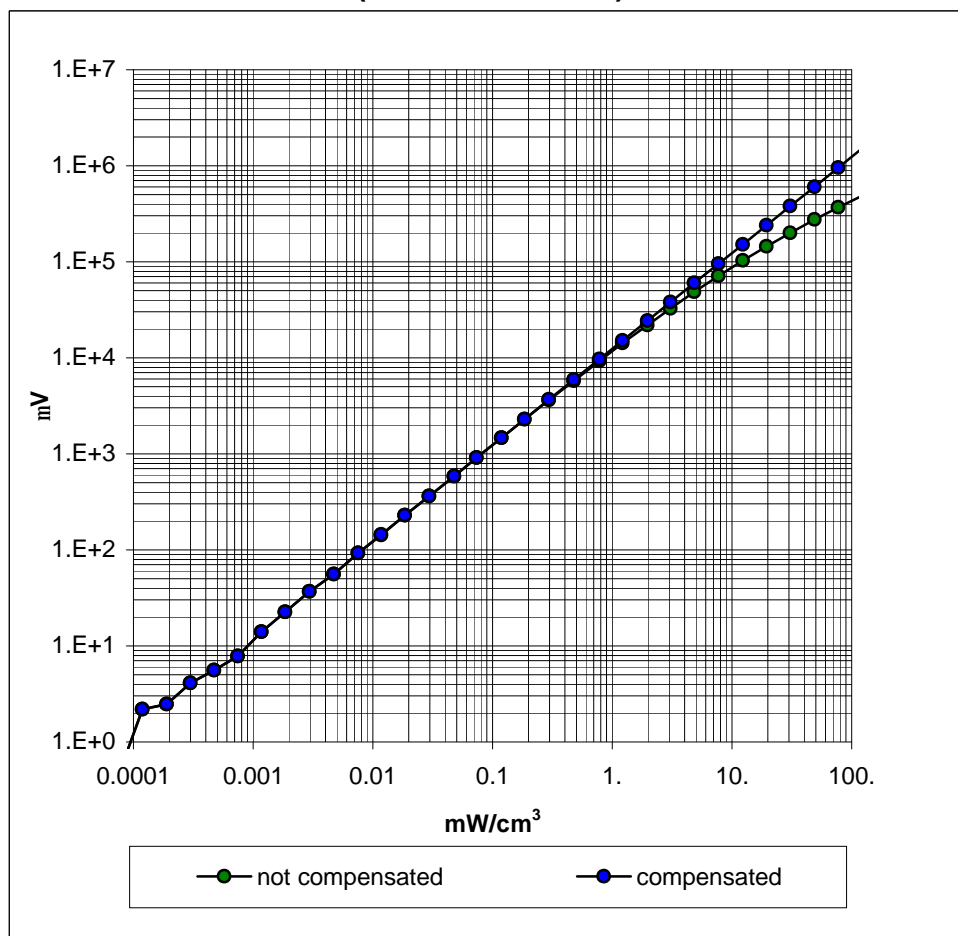

## Conversion Factor Assessment

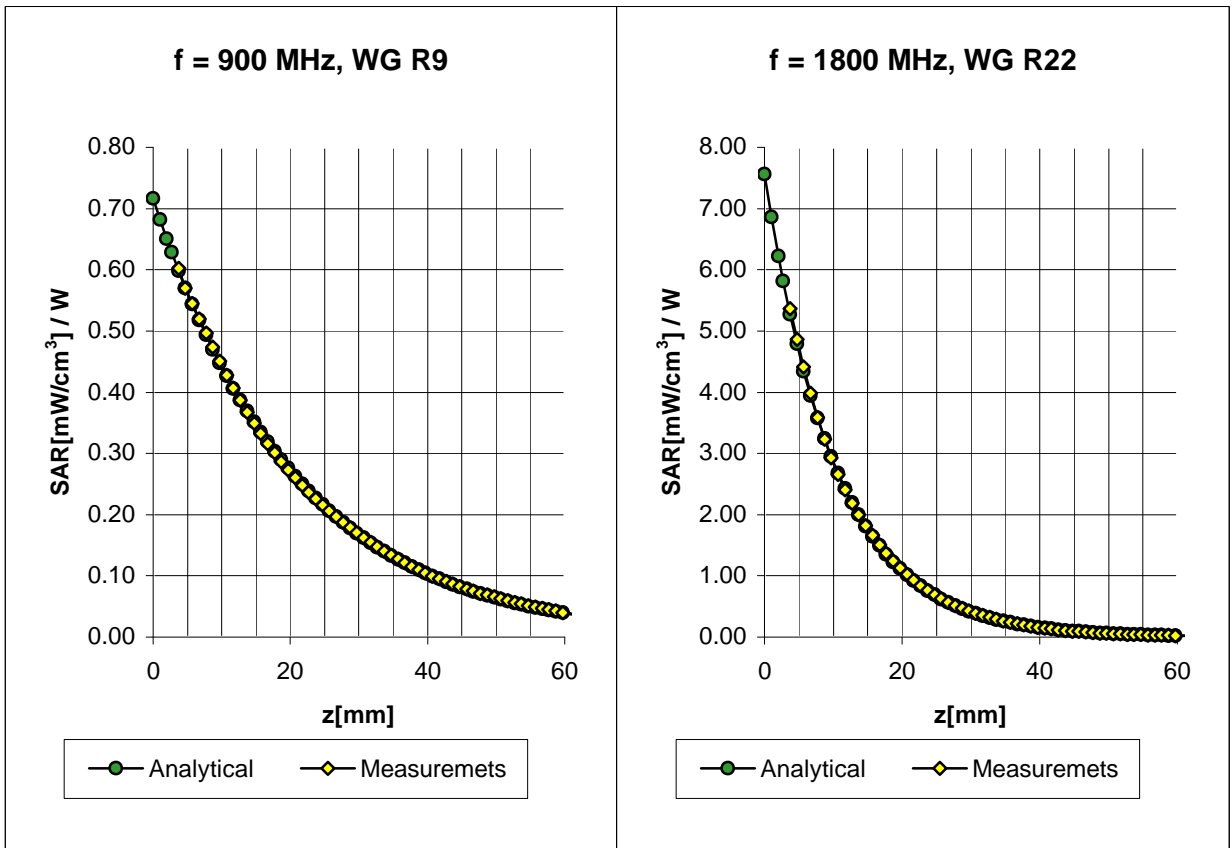

## Receiving Pattern (f) ( in brain tissue, z = 5 mm )

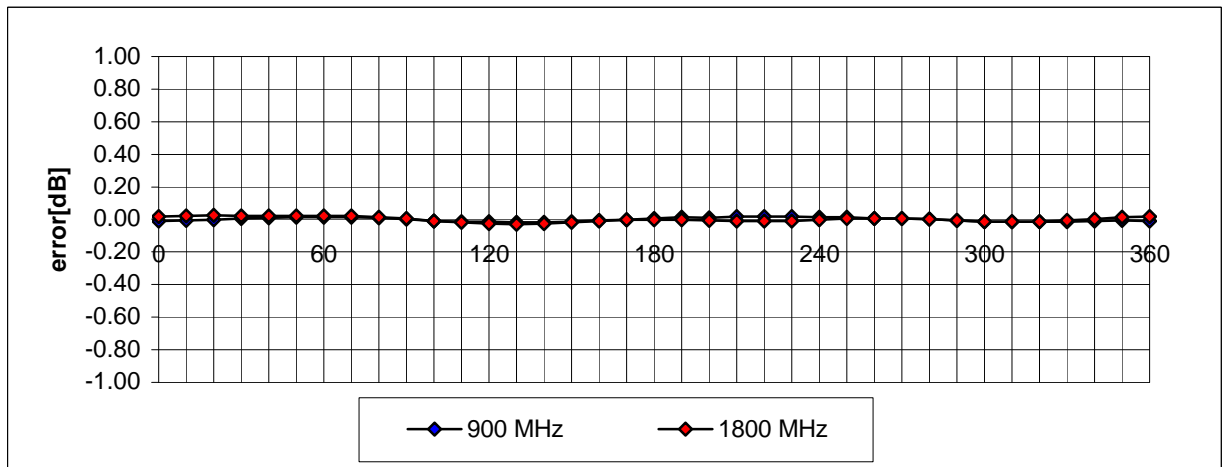



***APPENDIX D - SAR TEST SETUP PHOTOGRAPHS***

**HAND SAR TEST SETUP**  
**Front Side of EUT**  
**(0cm Separation Distance)**

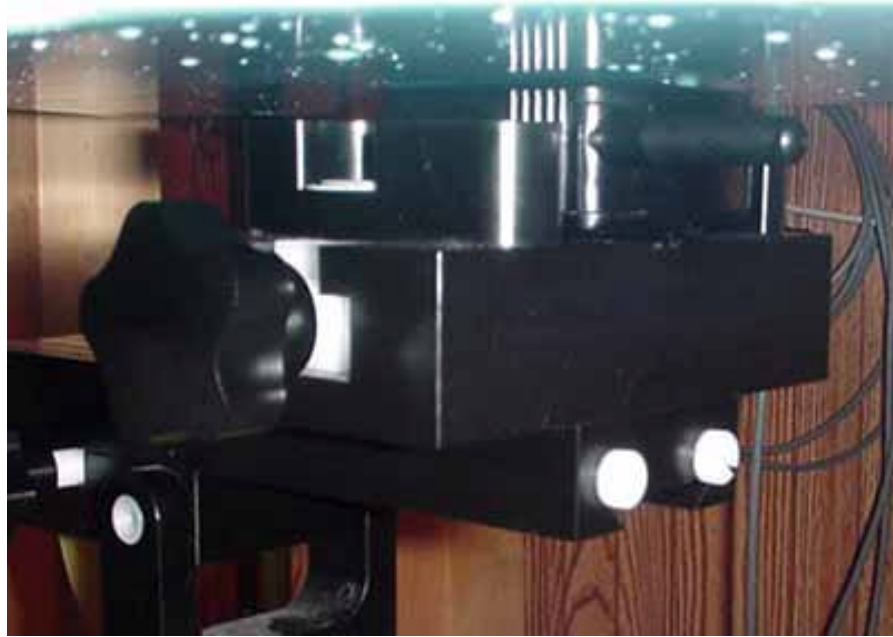

**HAND SAR TEST SETUP**  
**Back Side of EUT**  
**(0.0cm Separation Distance)**

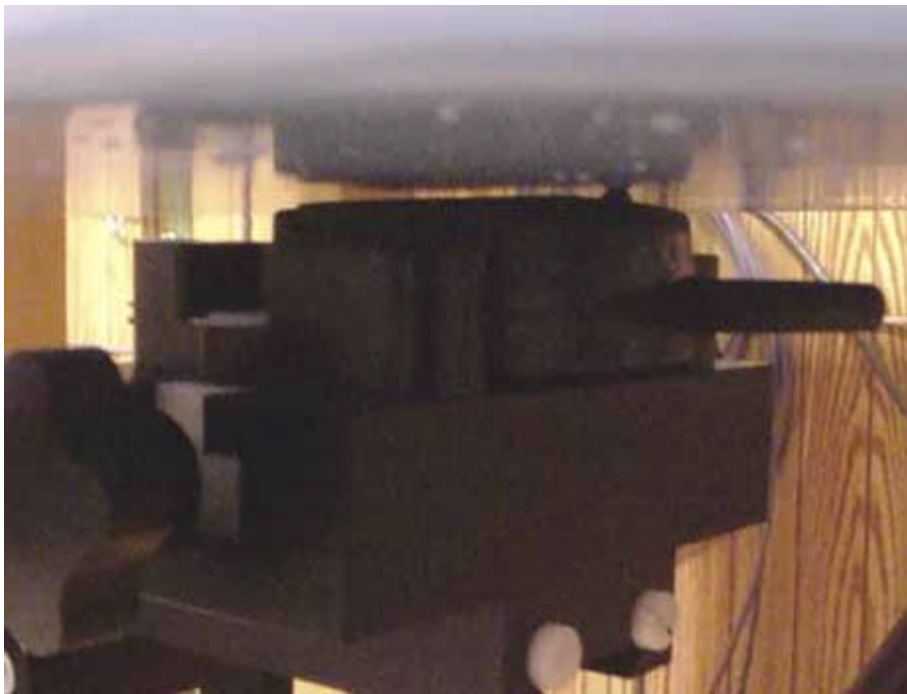

**HAND SAR TEST SETUP**  
**Antenna Side of EUT**  
**(0.0cm Separation Distance)**

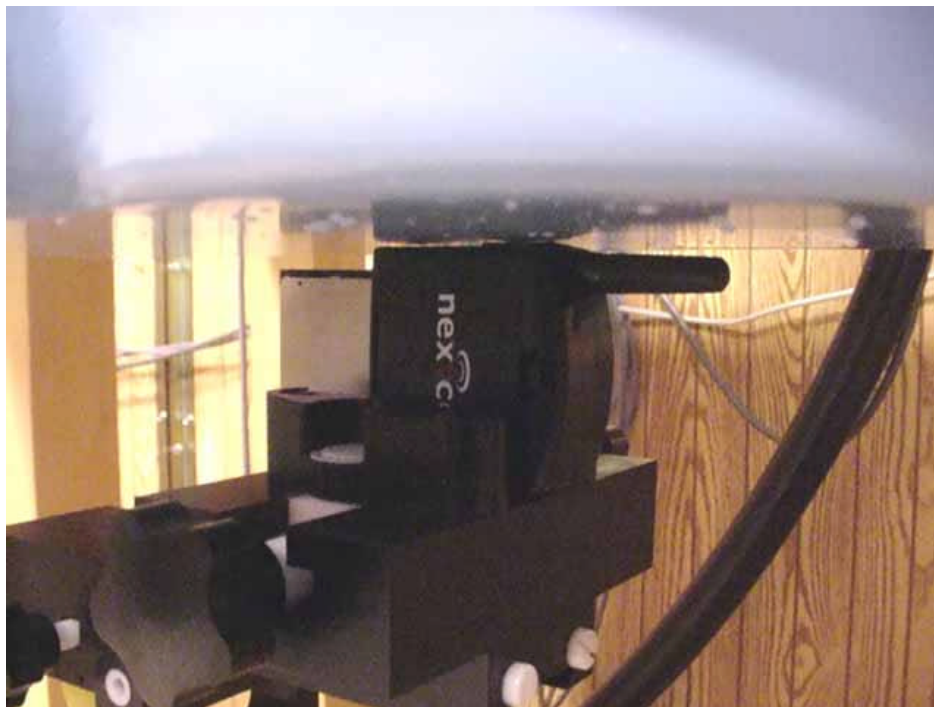
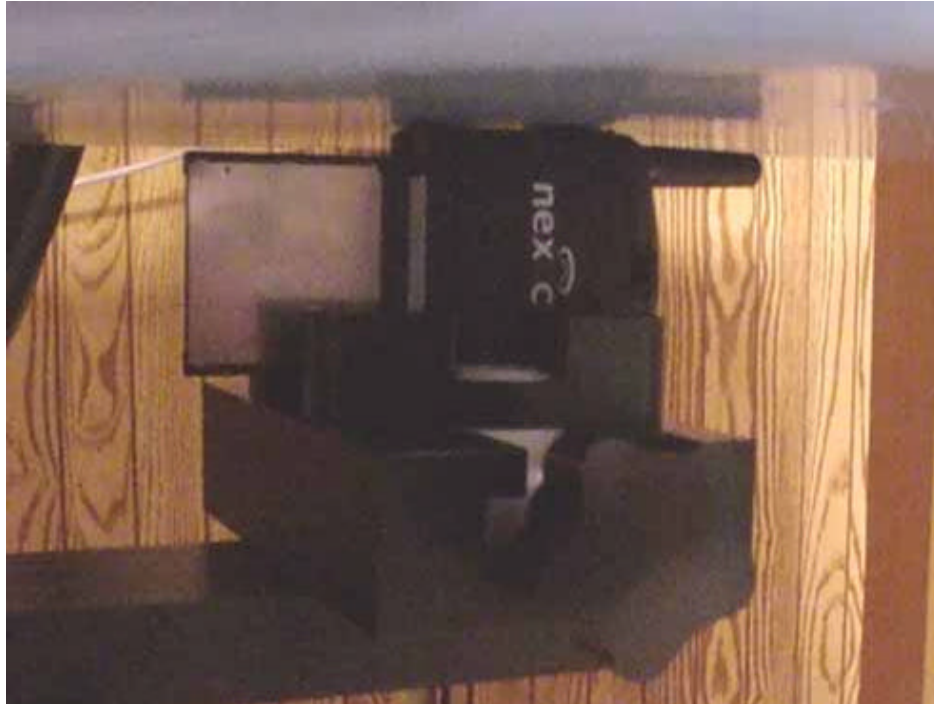

**BODY SAR TEST SETUP**  
**Front Side of EUT**  
**(1.0cm Separation Distance)**

